Source: ETSI TC-BTC

Reference: DTR/BTC-01026

UDC: 621.39

Key words: PTN

**Private Telecommunication Network (PTN);
General principles and service aspects**

ETSI

European Telecommunications Standards Institute

ETSI Secretariat

Postal address: 06921 Sophia Antipolis Cedex - FRANCE

Office address: Route des Lucioles - Sophia Antipolis - Valbonne - FRANCE

Tel.: + 33 92 94 42 00 - Fax: + 33 93 65 47 16

© European Telecommunications Standards Institute 1994.

All rights reserved.

No part may be reproduced except as authorised by written permission. The copyright and the foregoing restriction on reproduction extend to all media in which the information may be embodied.

Foreword

This Technical Committee Reference Technical Report (TCR-TR) has been prepared by the European Computer Manufacturers Association (ECMA) to serve as a platform for their standardization activities in the area of Private Telecommunication Networks (PTNs).

This TCR-TR has been developed over the period 1989 to 1991. It is applicable to PTNs and Private Telecommunication Network eXchanges (PTNXs), which may be Integrated Service Private Branch Exchanges (ISPBXs) or equivalent public network equipment providing the same services ("IS-CENTREX").

This TCR-TR sets, explicitly or implicitly, a number of base concepts which may not be known by public network operators or by manufacturers of public network equipment, although a number of these general items have condensed in standards other than from ETSI, such as:

- ENV 41004: Reference configuration for connectivity relations of private telecommunication network exchanges.
- ENV 41005: Method for the specification of basic and supplementary services of private telecommunications networks.
- ENV 41006: Scenarios for interconnections between exchanges of private telecommunications.
- ENV 41007-1: Definition of terms in private telecommunication networks; Part 1: Definition of general terms.
- DIS 11579: Information Technology - Private Integrated Services Network - Reference Configuration; Part 1: Reference Configuration for PISN Exchanges (PINX).
- CCITT I.320: ISDN Protocol Reference Model (in particular figure 7/I.320).

This TCR-TR is intended to serve as a platform for the work of the Technical Committee Business TeleCommunications (BTC) in the area of business communications.

It should also be noted that ongoing work within BTC in the area of Virtual Private Networking (VPN), see work item DTR/BTC-01041, may result in updates/revisions to some of the definitions used in this TCR-TR and a subsequent edition of this TCR-TR will then be produced.

This TCR-TR was produced by ECMA using the ECMA guidelines for the production of technical reports and using the ECMA stylesheet. In order to avoid undue delays in the processing of this TCR-TR it has been agreed that this TCR-TR will not be converted to the ETSI stylesheet.

Table of Contents

	Pages
Section 1 - General	1
1 Scope	1
2 Field of application	1
3 References	1
4 Definitions	4
4.1 PTN Access	4
4.2 Inter-PTNX Connection	4
4.3 Intervening Network	5
4.4 Private Telecommunication Network (PTN)	5
4.6 User	5
5 Structure of this Technical Report	5
Section 2 - Basic Concepts	6
6 Reference Configuration for PTNX Calls	6
7 Architecture	8
7.1 PTN Topology	8
7.2 Routeing Hierarchy	9
7.3 Capability Structures of a PTN	10
7.4 Capabilities of a PTN	11
7.4.1 PTN Low Layer Capabilities	11
7.4.2 Access Capability	13
7.5 PTNs connected to the Public ISDN	14
7.5.1 Interworking of PTN and Public ISDN Capabilities	14
7.5.2 Solutions for Accessing the Public ISDN Packet Switching Capabilities	14
7.6 Interconnected PTNXs	16
7.6.1 Overlay Concept	17
7.6.2 Capability Structure of a PTN Employing IVNs	18
8 Extended protocol reference model	20
8.1 Planes for Communication across the IVN	20
8.1.1 IVN Control Plane (NC)	20
8.1.2 IVN User Plane (NU)	20
8.2 Planes for Communication across the PTN	20
8.2.1 PTN Control Plane (PC)	20

Section 3 - Inter-PTNX Connections	22
9 Introduction	22
9.1 Multiple Instances of Q and C Reference Points	22
9.2 Shared Access Use	22
10 Scenarios	24
10.1 Type 1 Scenarios: Dedicated Systems	24
10.1.1 Scenario 1.1 - Dedicated Physical Link	24
10.1.2 Scenario 1.2 - Dedicated Transmission System	25
10.2 Type 2 Scenarios: Permanent IVN Connections	25
10.2.1 Scenario 2.1 - Permanent Circuit-Switched	25
10.2.2 Scenario 2.2 - Permanent ISDN Signalling	25
10.2.3 Scenario 2.3 - Permanent Virtual Call	26
10.3 Type 3 Scenarios: On-Demand Public Network Connections	26
10.3.1 Scenario 3.1 - On-Demand Circuit-Switched	26
10.3.2 Scenario 3.2 - On-Demand ISDN Signalling Signalling Connection	27
11 Protocol models	28
11.1 Scenario 1.1: Dedicated Physical Link	28
11.2 Scenario 1.2: Dedicated Transmission System	29
11.3 Scenario 2.1: Permanent Purely Circuit-Switched Connection	29
11.4 Scenario 2.2: Permanent Circuit-Switched/ISDN Signalling Connection	30
11.5 Scenario 2.3: Permanent Circuit-Switched/Packet Switched Signalling Connection	30
12 Evaluation and standardization of scenarios	32
Section 4 - Addressing	33
13 General	33
13.1 Smallest Addressable Entity	33
13.2 Addressing Principles	35
13.2.1 The ISO Global OSI Network Addressing Principle	36
13.2.2 The CCITT ISDN Addressing Principle	37
13.2.3 The Domain Specific Part Addressing Principles	37
13.2.3.1 The ECMA Addressing Principles	38
13.2.3.2 The MAP Addressing Principles	38
13.3 Purpose of Addresses	39
13.3.1 Selection	39

13.4	Address Interworking	40
13.5	Address Values of the Public ISDN Addressing Domain	40
13.6	Addressing Principles in LANs	40
14	PTN Numbering Concept	40
14.1	Numbering Plans of PTNs	40
14.2	Private Numbering Plan Structure	42
14.5	Knowledge about other Numbering Plans	43
15	Support of subaddressing in PTNs	43
15.1	Embedment of OSI Network Layer Addresses in Concatenated PTN Addressing Information	43
15.2	Embedment of Other Information in the Subaddress	44
Section 5 - Routing		45
16	General	45
17	Routing requirements	46
17.1	Functional Requirements	46
17.1.1	Factors Influencing Routing through a PTN	46
17.1.2	Factors Influencing Routing to Another Network	47
17.1.3	Factors Influencing the Selection of Networks beyond the Next Network	47
17.1.4	Other Factors Influencing Route Selection	48
17.2	Performance Requirements	48
18	Routing mechanisms	48
18.1	Routing Information Base	48
18.2	Source and Destination Routing	49
18.2.1	Advantages of Source Routing Compared with Destination Routing	49
18.2.2	Advantages of Destination Routing Compared with Source Routing	49
18.2.3	Hybrid Methods	50
18.2.4	Impact on Signalling for Call Control	50
18.3	Subjects for Standardization	51
Section 6 - Services		51
19	General Service Considerations	51
19.1	Classification of Services	51
19.2	Control of Basic Services	52
19.3	Control of Supplementary Services	52
19.4	Specification Method for ECMA Standards on Services	53

19.4.1	Service Model for Stage 1 Specifications	53
19.4.2	Service Model for Stage 2 Specifications	54
19.5	Relationship to Services Provided in Public ISDNs	54
19.6	Service Interworking between PTNs and Public ISDNs	55
19.7	Additional Network Features	57
Annex A - Off-Premises PTN Users		59
Annex B - PTNX Connections to Public ISDNs		61
Annex C - Interworking for Identification Numbers between Public ISDN and PTN		63
Annex D - Abbreviations and Acronyms		65

Section 1 - General

1 Scope

A Private Telecommunication Network (PTN) provides switching and transmission functions for the provision to its users of telecommunication services similar to those provided by public ISDNs, and also extends to its users services provided by public ISDNs. Public ISDNs are described in CCITT recommendations. The main purpose of a PTN is to serve the communication needs of an organisation rather than to provide services to the general public.

A PTN comprises one or more interconnected Private Telecommunication Network Exchanges (PTNX) and their interconnecting links as provided by intervening networks. It may also be supported by Virtual Private Network (VPN) features offered by an intervening network.

This Technical Report discusses some of the technical aspects of PTNs and identifies areas for standardization. It also provides a common framework of concepts and terminology for standards in this field.

The discussion of VPN features provided by an intervening network is beyond the Scope of this Technical Report. However, if VPN features are offered by other networks, they should follow the concepts established in this Technical Report and related Standards for PTNs consisting of PTNXs.

Management aspects of PTNs are not subject of this Technical Report. A management framework is described in ECMA TR/54.

2 Field of application

This Technical Report applies to:

- Private Telecommunication Networks and their exchanges, e.g. Integrated Services Private Branch Exchanges (ISPBX) and/or Integrated Services Centrexes (ISCTX);
- Intervening Networks, e.g. public ISDNs, which are employed to support Private Telecommunication Networks by providing interconnecting links between PTNXs ;
- Public ISDNs with regard to support of interworking with PTNs or PTNXs.

3 References

ECMA-102	Rate Adaptation for the Support of Synchronous and Asynchronous Equipment using the V.-Series Type Interface on a PTN, IInd Edition (1987)
ECMA-117	Domain Specific Part of Network Layer Addresses (1986)
ECMA-133	Reference Configuration for Calls through Exchanges of Private Telecommunication Networks (1989)
ECMA-134 / ENV 41 005	Method for the Specification of Basic and Supplementary Services of Private Telecommunication Networks (1989)
ECMA-135 / ENV 41 006	Scenarios for Interconnections between Exchanges of Private Telecommunication Networks (1989)
ECMA-142	Specification, Functional Model and Information Flows for Control Aspects of Circuit Mode Basic Services in Private Telecommunication Networks (1990)
ECMA TR/43	Packetized Data Transfer in Private Switching Networks (1987)

ECMA TR/44	An Architectural Framework for Private Networks (1989)
ECMA TR/50	Inter-Domain Intermediate Systems Routing (1989)
ECMA TR/54	A Management Framework for Private Telecommunication Networks (1990)
ISO 7498	Information Processing Systems - Open System Interconnection - Basic Reference Model. Addendum 3: Naming and Addressing (1984)
ISO 8348	Information Processing Systems - Data Communications - Network Service Definition. Addendum 2: Network Layer Addressing (1988)
ISO 10589	Information Processing Systems - Intermediate system to Intermediate system routing protocol (1991)
ISO/IEC TR-9575	Information Technology - Telecommunications Information Exchange between Systems - OSI Routing Framework (1990)

Note 1:

For the CCITT recommendations listed below the Blue Book version, (Melbourne 1988) shall apply.

CCITT Rec. E.164	Numbering Plan for the ISDN Era
CCITT Rec. F.69	Plan for Telex Destination Codes
CCITT Rec. I.130	Method for the Characterization of Telecommunication Services supported by an ISDN, and Network Capabilities of an ISDN
CCITT Rec. I.210	Principles of Telecommunication Services and the Means to describe them
CCITT Rec. I.220	Common dynamic Description of basic Telecommunication Services
CCITT Rec. I.230	Definition of Bearer Services
CCITT Rec. I.240	Definition of Tele-Services
CCITT Rec. I.310	ISDN - Network Functional Principles
CCITT Rec. I.320	ISDN Protocol Reference Model
CCITT Rec. I.324	ISDN Network Architecture
CCITT Rec. I.325	Reference Configuration for ISDN Connection Types
CCITT Rec. I.330	ISDN Numbering and Addressing Principles
CCITT Rec. I.333	Terminal Selection in ISDN
CCITT Rec. I.334	Principles Relating ISDN Numbers /Addresses to the OSI Reference Model Network Layer Addresses
CCITT Rec. I.411	ISDN User-Network Interfaces - Reference Configuration
CCITT Rec. I.412	ISDN User-Network Interfaces - Interface Structure and Access Capabilities
CCITT Rec. Q.513	Exchange Interfaces for Operations, Administration and Maintenance
CCITT Rec. Q.931 / ETS 300 102	ISDN User-Network Interfaces - Layer 3 Specification
CCITT Rec. X.25	Interface between Data Terminal Equipment (DTE) and Data Circuit-Terminating Equipment (DCE) for Terminals Operating in the Packet Mode and Connected to Public Data Networks by Dedicated Circuit

CCITT Rec. X.31	Support of Packet Mode Terminal Equipment by an ISDN
CCITT Rec. X.75	Packet-Switched Signalling System between Public Networks Providing Data Transmission Services
CCITT Rec. X.121	International Numbering Plan for Public Data Networks
CCITT Rec. X.200	Reference Model for Open Systems Interconnection for CCITT Applications
ETS 300 011	Integrated Services Digital Network (ISDN) Basic User Network Interface Layer 1 Specification and Test Principles
ETS 300 012	Integrated Services Digital Network (ISDN) Primary Rate User Network Interface Layer 1 Specification and Test Principles
Manufacturing Automation Protocol (MAP)	3.0 Implementation Release (July 1987)

4 Definitions

Figure 1 gives an overview of a number of terms defined below.

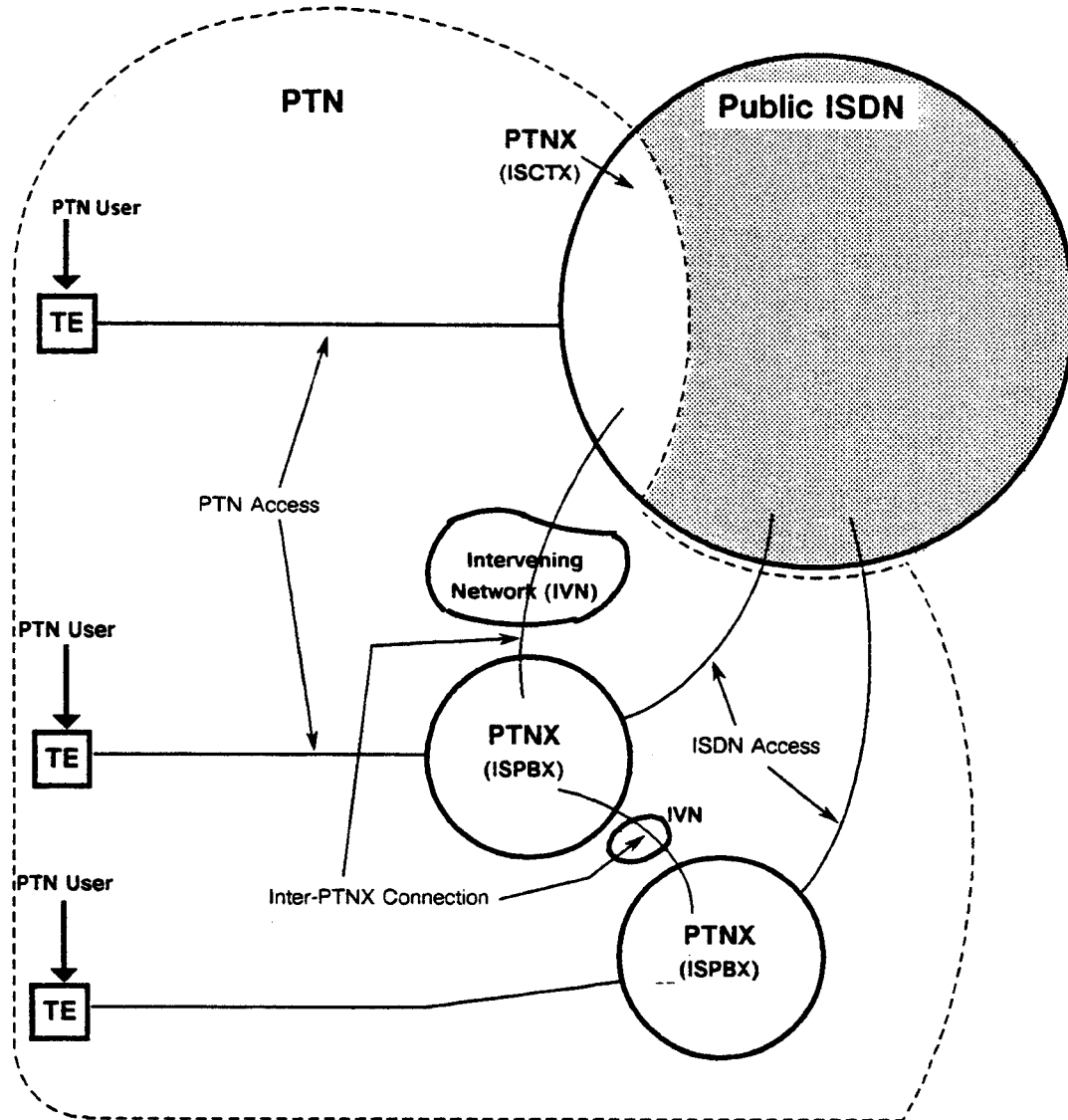

Figure 1 - Terminology in the Private Telecommunication Network Environment

Note 2:

In most of its recommendations (Blue Book, Melbourne 1988), CCITT globally distinguishes between "User" and "Network", without further distinction between NT2 and TE. Furthermore, the special case of a PTNX as one specific NT2 representative has not been covered by CCITT so far. However, any specification applicable to the PTN environment needs a more specific terminology, which is able to cover different types of PTNXs (e.g. ISPBXs and ISCTXs), in a non-discriminatory way.

4.1 PTN Access

The line connecting a terminal (or in the case of multipoint configurations: terminals) to a PTNX.

4.2 Inter-PTNX Connection

The connection between two inter-connected PTNXs. It is supported by an intervening network.

4.3 Intervening Network

A network which intervenes between any two PTNXs in order to provide inter-PTNX connections.

4.4 Private Telecommunication Network (PTN)

A network comprising one or more interconnected PTNXs. The PTN provides PTN services to its users which are based on those provided by its PTNXs. A PTN may comprise more than one PTNX spread over more than one user premises. In this case, inter-PTNX connections between the PTNXs serving the individual premises are required. The inter-PTNX connections are considered part of the PTN.

In the context of this Technical Report a PTN is considered a private ISDN.

4.5 Private Telecommunication Network Exchange (PTNX)

A nodal entity in a PTN which provides autonomous and automatic switching and call handling functions used for the provision of telecommunication services which are based on those specified for public ISDNs.

Note 3:

If applicable, a PTNX provides:

- *telecommunication services within its own area, and/or*
- *telecommunication services from a public ISDN, and/or*
- *telecommunication services from other public or private networks, and/or*
- *within the context of a PTN, telecommunication services from other PTNXs*

to users of the same and/or another PTNX.

A PTNX may be represented by an ISPBX, or by equipment which is physically part of the equipment of, for example, a public ISDN local exchange.

4.6 User

The generic term for an entity, i.e. a process or human being, using, via the terminal, the network layer service provided by a network, independently of whether this is in a PTN, a public ISDN or another network.

4.7 PTN User

A user of the network layer service provided by a PTN.

4.8 Virtual Private Network Feature

A feature within an intervening network which supports basic or supplementary services of a PTN, e.g. for conferencing, number translation, A-law/-law conversion.

5 Structure of this Technical Report

This Technical Report is structured into a number of Sections which cover individual aspects of PTNs and Public ISDNs:

- Section 1: covers the general part, such as scope and definitions, which apply to all subsequent Sections.
- Section 2: discusses basic concepts of PTNXs and PTNs, such as PTN architecture, connection types etc.
- Section 3: discusses the interconnection of distant PTNXs in order to form Private Telecommunication Networks: the necessary provisions on the PTN side as well as the provision of bearer services by intervening networks;

- Section 4: discusses addressing aspects within PTNs, between PTNs and non-ISDN private networks, between PTNs and public ISDNs, and between PTNs and non-ISDN public networks;
- Section 5: discusses routing within a PTN;
- Section 6: discusses services provided by a PTN, and in particular the impact of interworking with corresponding services in public ISDNs.

Section 2 - Basic Concepts

This Section discusses the general concepts which apply to a PTN and its PTNXs. A reference configuration, architecture and connection types, and a protocol reference model are discussed. These general considerations are suitable for the applications:

- stand-alone PTNX,
- PTNX interworking with public ISDN, and
- PTNXs interconnected via intervening networks.

6 Reference Configuration for PTNX Calls

CCITT's user-to-network access reference configuration (CCITT Rec. 1.411) classifies ISPBXs as a specific implementation of an NT2 functional grouping which is connected to the Public ISDN at its T reference point and fulfils ISDN access functions. Moreover, a PTNX provides other functions in addition to functions for access to the public ISDN, and in particular can provide the following additional functions:

- internal communication between its users;
- direct communication with one or more other PTNXs, via inter-PTNX connections.

Note 4:

PTNXs are not restricted to offering to their users the same services as public ISDNs. In addition they can provide PTNX specific basic and supplementary services and enhanced forms of public ISDN services.

Note 5:

PTNXs may also connect to dedicated private networks (eg. LANs and private telephony networks) and to public non-ISDN networks (e.g. PSTN). In each case the PTNXs will perform specific gateway functions. These functions are beyond the scope of this Technical Report.

Intervening networks (IVN) will provide the services which are necessary to carry inter-PTNX connections; these will allow the transfer of user information as well as of signalling information between the PTNXs. The control of IVNs is a further function which a PTNX may provide in addition to NT2 functionality.

Standard ECMA-133 defines a reference configuration for PTNX calls and derives two reference points, C and Q, relating to inter-PTNX calls. An excerpt is reproduced in figure 2.

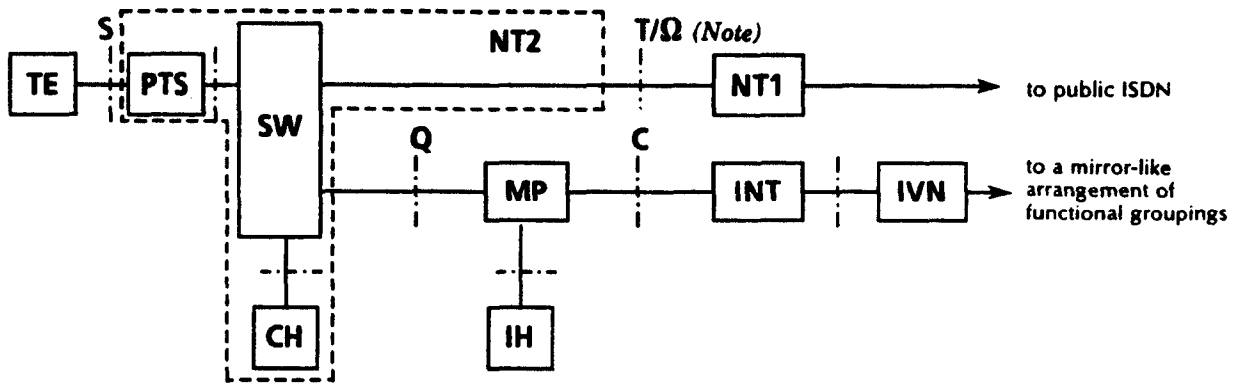

Legend for Functional Groupings:

CH = Call Handling	IH = Interconnection Handling	INT = Intervening Network Termination
IVN = Intervening Network	MP = Mapping	NT1, NT2 = Network Termination 1, 2
PTS = Private Termination System	SW = Switching	TE = Terminal Equipment

Note: The *T* reference point applies to the case where the PTNX is an ISPBX.
 The Ω reference point applies to the case where the PTNX is an ISCTX. The specification of the Ω reference point is beyond the scope of this Technical Report.

Figure 2 - Reference Configuration for PTNX Calls

This Reference Configuration can be interpreted as a superset of the user-to-network access reference configuration, as defined in CCITT Rec. I.411. The dotted line showing the extent of the NT2 functional grouping helps to show the relationship to the reference configuration of CCITT Rec. I.411. NT2 functions (i.e., public ISDN access functions) are spread across the SW, CH and PT functional groupings.

In addition, figure 2 shows the reference point. This reference point is not yet defined in Standard ECMA-133 or in CCITT Rec. I.411. The reference point is used here to conceptually indicate the boundary between the ISCTX variant of a PTNX and the public ISDN.

The Reference Configuration for PTNX Calls will be used throughout this Technical Report.

Note 6:

Examples of commonality have been identified which show the similarity of the T and the reference point.

T and Ω have in common that they define the boundary between two different network operating authorities, in particular with regard to

- numbering,
- charging,
- management,
- routing, etc.

However, also examples of dissimilarity have been found, such as that a standardized physical interface is not necessarily required at Ω . This might mean that there is :

- no need for a defined access structure;
- no transmission system required;
- no Layer 1 and no Layer 2 specifications etc. required.

Note 7:

Interfaces at the C reference point become identical with those at a T reference point, if the IVN is a public ISDN. Since IVNs do not see the Q reference point, PTNXs always appear to a public ISDN as if connected at a T reference point. The functional groupings between the Q and C reference points are part of the PTNX.

Note 8:

A set of Q reference points (Q₁, Q₂...) is also used in public ISDNs within the context of the Telecommunications Management Network TMN. Since the Q reference point defined for the PTN is not seen by the public ISDN, and since the TMN Q reference points are not seen by the PTN, occurrence of any confusion is considered unlikely.

The concept of Q reference points relies on an ideal model, which allows the immediate interconnection of any pair of PTNXs.

Within this model the PTNXs have functions at their disposal for cooperation within a PTN, as if the PTNXs were co-sited.

In practice, the PTNXs will not be co-sited and will need bearer services of IVNs which convey the signalling information flows for the functions to be performed between them and, in addition, provide connection types according to the bearer services required for PTN user information transfer. The C reference point denotes the point of interconnection between the PTNX and the IVN. The MP functional grouping provides the necessary adaptation of a PTNX to a particular type of IVN, see figure 3.

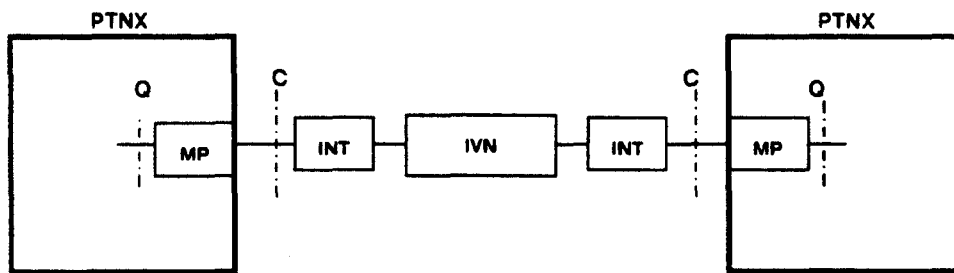

Figure 3 - Configuration of a PTN Employing an Intervening Network

7 Architecture

Whereas the Reference Configuration for PTNX Calls lays the foundation for the conceptual principle for the delimitation of a single PTNX from its terminals, the public ISDN and IVNs, this Chapter looks into the architectural aspects of the PTN infrastructure and describes how the capabilities of a PTNX are distributed over its functional groupings.

This can be seen as two different approaches of breaking down a PTN into its PTNXs: one leads to the view of its topology and hierarchy, whereas the other one leads to the view of its capabilities.

7.1 PTN Topology

A PTN can consist of one PTNX, or of two or more PTNXs. Thus, the users of a PTN can be connected

- to the same PTNX;
- to adjacent PTNXs;
- to non-adjacent PTNXs, i.e. PTNXs connected only indirectly via other PTNXs.

A PTN consisting of a single PTNX is shown in figure 4.

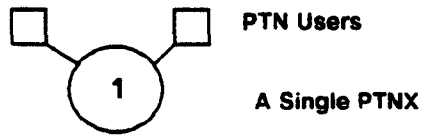

Figure 4 - Single PTNX PTN Topology

Whenever a PTN consists of more than one PTNX, IVNs need to be employed for their interconnection, as shown in figure 5.

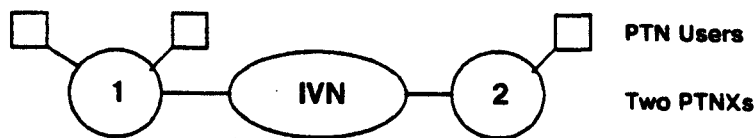

Figure 5 - PTN Topology Employing an IVN

PTNXs need not be directly interconnected; instead, connections between their PTN users can be routed via one or more transit PTNXs. An example for a topology with one transit PTNX is given in figure 6.

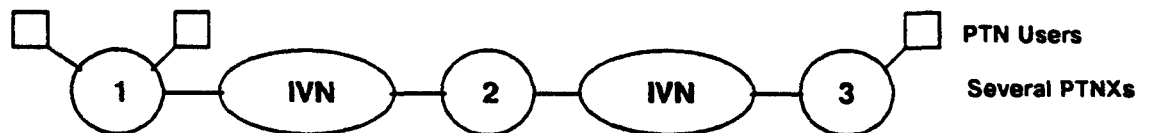

Figure 6 - PTN Topology with Transit PTNX (Example)

Each of the PTNXs interchanges signalling information with its neighbour via Q reference points. The PTNXs adapt to (and, if applicable, control) the IVNs providing the inter-PTNX connections, at C reference points.

In the example shown in figure 5, PTNXs 1 and 3 serve as pure originating or terminating PTNXs, whereas PTNX 2 serves as a pure transit-PTNX.

Note 9:

CCITT Rec. 1.325 describes a method of subdividing a network into connection elements (CE). Two types of CEs are distinguished: access CEs and transit-CEs.

In PTNs an originating/terminating PTNX belongs to a private access CE and a transit-PTNX belongs to a private transit CE.

The access between a PTN and the public ISDN belongs to a (public ISDN) access CE.

A PTNX may provide both, the private access CE and the private transit CE in one and the same physical implementation.

CEs consist of Connection Related Functions (CRF) and transmission functions.

7.2 Routeing Hierarchy

Within a particular PTN a multi-stage routeing hierarchy may be implemented by combining private transit-CEs in an appropriate way. If this is done on a permanent basis, they will be classified according

to the hierarchical level, e.g., by transit-PTNXs (transit CRFs) of different classes. If PTNXs are interconnected on-demand, no firm routing hierarchy will be established. Instead, only a numbering hierarchy will be achieved, see Section 4.

If the PTN employs PTNXs which provide combined private access and transit-CEs, and if these PTNXs are also directly connected to the public ISDN's access CEs, the hierarchy with relation to the public ISDN will be different from the intra-PTN hierarchy. Both hierarchies overlay each other, and for reasons of clarity it is important to indicate whether the public or private hierarchy is meant.

For a particular PTN the private hierarchy will usually be determined on the basis of connectivity arrangements between the various PTNXs of a PTN. Such arrangements can be of a mesh form or of a star form or of a mixture of both forms (the example shown in figure 5 can be understood as the trivial case of a star form). The arrangements are normally optimized with regard to the traffic distribution throughout the PTN and may have impact on the routing requirements and on the numbering plan of the PTN.

7.3 Capability Structures of a PTN

Based on the capability structure of a PTN, the capability structure of an overall ISDN, i.e. a PTN interworking with a public ISDN, is considered. Finally, the aspects of a PTN consisting of several PTNXs and employing IVNs are discussed.

In actual PTN implementations some of the functions will be provided within PTNXs whereas other specific PTN functions may be obtained from IVNs, or from a public ISDN, if applicable.

A basic component of a PTN is the capability of circuit-switching of 64 kbit/s end-to-end connections. In addition to the connection types supporting this capability, certain components of a PTN may support other connection types, such as packet mode connection types or $n \times 64$ kbit/s circuit mode connection types.

Figure 7 shows the basic capability structure of a PTN, as being developed from CCITT Rec. 1.324.

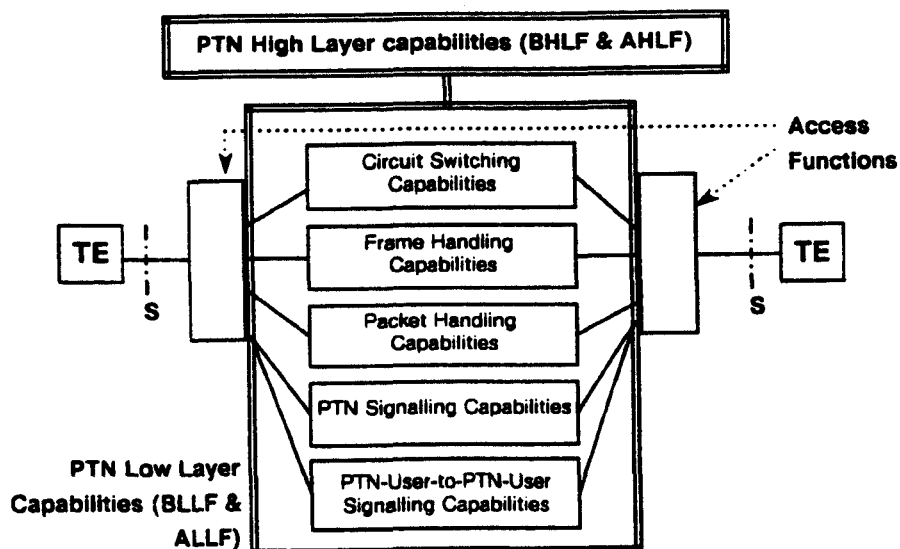

Legend: AHLF = Additional High Layer Functions ALLF = Additional Low Layer Functions
 BHLF = Basic High Layer Functions BLLF = Basic Low Layer Functions

Note: In conjunction with some public or private teleservices, AHLFs and BHLFs can be provided inside or outside the PTN.

Figure 7 - Basic Capability Structure of a PTN

7.4 Capabilities of a PTN

The basic capability structure contains the following capabilities of a PTN:

- PTN Low Layer capabilities; these may include:
 - circuit-switching capabilities;
 - frame handling capabilities;
 - packet handling capabilities;
 - PTN signalling capabilities;
 - PTN-user-to-PTN-user signalling capabilities.
- Access functions; these include:
 - termination of the physical medium;
 - Layer 1 functions;
 - access signalling capabilities;
 - PTN High Layer capabilities;

Distinction can be made between basic and additional high layer capabilities (BHLFs and AHLFs). They can, in conjunction with some public or private teleservices, be provided inside or outside the PTN. BHLFs and AHLFs are considered beyond the scope of this Technical Report.

Higher layer functions (HLF) necessary to provide the capabilities may be accessed by the means of any of the above mentioned functional entities.

Note 10:

Not all of these components need to be provided by a distinct PTNX, but can be combined as appropriate for a particular PTN implementation.

7.4.1 PTN Low Layer Capabilities

The main low layer capabilities of the PTN, as shown in figure 7, are described hereafter.

7.4.1.1 Circuit-Switching Capabilities

Circuit-switched connections with an information transfer rate of up to 64 kbit/s are carried by B-channels at PTN accesses, which are switched by the circuit-switching functional entities of the PTN. Circuit-switching can also be applied to information transfer rates greater than 64 kbit/s.

User bit rates of less than 64 kbit/s are rate adapted to 64 kbit/s, e.g. as described in ECMA-102, before switching in the PTN. Multiple information streams from a given user may be multiplexed together in the same B-channel, but for circuit-switching an entire B-channel will be switched to a single PTN-user access.

7.4.1.2 Frame Handling Capabilities

A number of frame mode bearer services are preliminarily described in Technical Report ECMA TR/43; they are also being studied in CCITT.

The type of functional entity involved in the provision of frame mode bearer services by a PTN is a Frame Handler (FH), which is based on one of the following principles:

- frame switching which allows, besides frame routing, the full termination of the Data Link Layer protocol, with all functions as defined for the service of the Data Link Layer;
- frame relaying which allows, besides frame routing, the partial termination of the Data Link Layer protocol. This includes the modification of the frame address information and the analysis and recalculation of the frame checking information. Further Data Link Layer functions are not provided, in particular no mechanisms for the repetition of invalid frames.

Such frames will be discarded instead, and it is left to the end-systems to take care of repetition, correction etc.

7.4.1.3 Packet Handling Capabilities

A number of packet mode bearer services are described in the CCITT 1.230 series of recommendations.

CCITT Rec. 1.310 indicates functional principles, CCITT Rec. X.31 defines a "Case B" for accessing the network's packet handling capabilities, and CCITT Rec. Q.513 gives a description of exchange connections. If applied to a PTN, these documents can constitute the basis for the description of packet switching functions in a PTN, see figure 8.

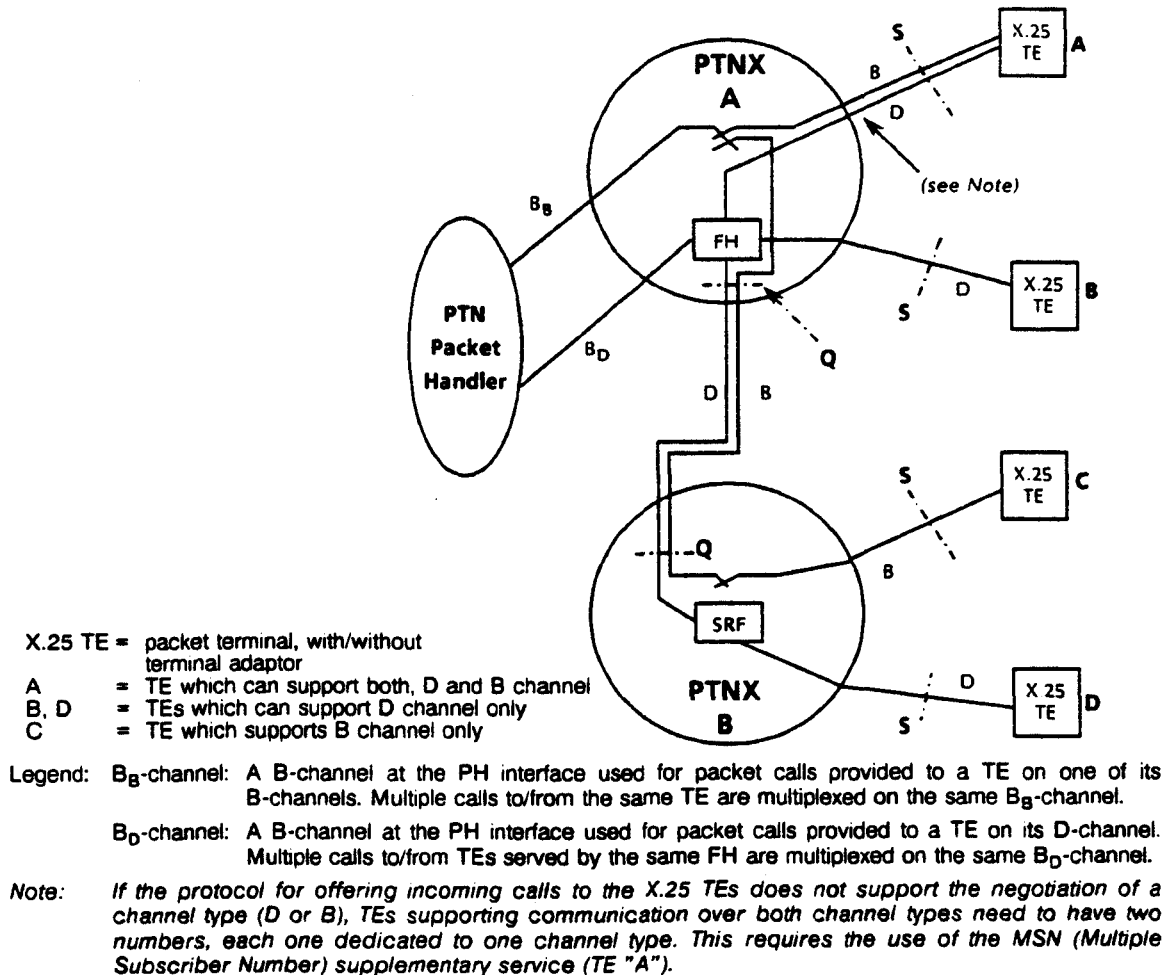

Figure 8 - Example of a PTN using Layer 2 Relaying or Switching Capability for Accessing a Packet Handler of the Private ISDN (X.31 Case B)

Two types of functional entities are involved in the provision of packet switched bearer services:

- Packet Handler (PH) containing switching and call handling functions relating to packet calls within the PTN;
- FH as described in 7.4.1.2;
- Switching or Relaying functions (SRF) providing layer 2 switching or relaying between D-channels for the interconnection of X.25 TEs with the PH.

Note 11:

The SRF can be considered as a subset of an FH which is restricted to switching and relaying between D-channels (i.e. not B-channels).

In addition, interworking functions can ensure interworking between PTN and packet switched data networks.

7.4.1.4 PTN Signalling Capability

This capability consists of the interchange and processing of information for the control of the circuit-switching, frame handling and packet handling capabilities used in the provision of basic and supplementary services.

7.4.1.5 PTN-User-to-PTN-User Signalling Capability

This capability consists of the end-to-end functions necessary to allow the interchange of signalling information between two PTN users whereby this signalling information is transparently conveyed through the PTN. The signalling information can be used for:

- indicating the protocol handling capabilities of the PTN users' endsystems; this type of information is marked appropriately and is typically exchanged during the establishment phase of a connection.
- enhanced addressing, i.e. beyond that provided by the numbering plan employed; this type of information is marked appropriately and is typically exchanged during the establishment phase of a connection.
- indicating additional functions during or after establishment of the connection between the PTN user; this type of information is only marked in a generic way, and therefore the additional functions need to be identifiable and thus addressable in a standardized way.

PTN-user-to-PTN-user signalling is associated with the access and intra-PTN signalling, related with connection control. It is carried on the D-channel and processed by the CRFs of the PTN.

7.4.2 Access Capability

The access capabilities include the functions which are necessary for

- termination of the physical medium;
- Layer 1 functions;
- access signalling capabilities.

7.4.2.1 Termination of the Physical Medium

This capability consists of the functions necessary to allow adaptation to the interface conditions at the PTN user-to PTN access.

CCITT Rec. I.412 describes the structure of standardized accesses, e.g. the basic and the primary rate access.

7.4.2.2 Layer 1 Capability

This capability consists of the functions which are necessary for the Layer 1 access procedures. In the case of point-to-multipoint configurations (basic access), these functions ensure that only one PTN user terminal can transmit on the D-channel of the access at any one time.

7.4.2.3 Access Signalling Capability

This capability consists of the functions necessary for secure interchange of signalling information between the PTN user and the PTN. The signalling information consists of information for the

control of basic and supplementary services, and of information interchanged with the peer PTN user.

7.5 PTNs connected to the Public ISDN

7.5.1 Interworking of PTN and Public ISDN Capabilities

The interconnection of a PTN with the public ISDN takes place at the T or reference point. The public ISDN provides its services across this reference point which are extended to PTN users via the ISDN interworking functions of the PTNX. As far as communication with users of the public ISDN is concerned, PTN users can only use services which are provided by the public ISDN and any other PTNX services which do not require the cooperation of the public ISDN, e.g. abbreviated dialling, local conferencing. The overall capability structure of a PTN interworking with the public ISDN via a gateway PTNX is shown in figure 9.

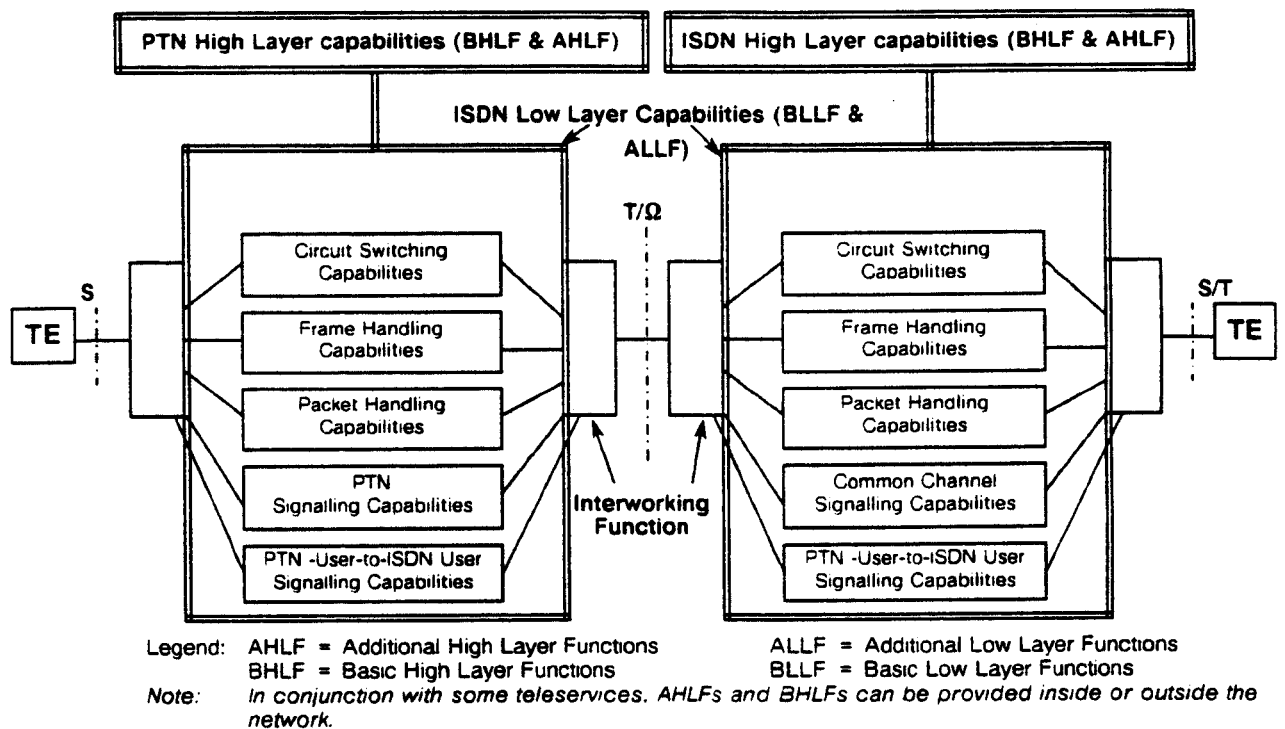

Figure 9 - Overall Capability Structure of a Private Telecommunication Network Interworking with the Public ISDN

The one-to-one mapping between the capabilities of a PTN and a public ISDN is conceptual only and has been chosen here as an example. It depends on the actual implementation whether an individual capability is supported or not, and it is up to the interworking functions in the PTN to ensure compatibility as far as achievable. This is either achieved by PTN-to-public ISDN signalling means, or it needs to be known by the PTN in advance. If no compatible capabilities are available, a request might have to be rejected.

7.5.2 Solutions for Accessing the Public ISDN Packet Switching Capabilities

7.5.2.1 PTN without PH

If a PTN does not provide a PH of its own, it can use the X.31 Case B principle for accessing a PH connected to or being part of a public ISDN. This can be achieved in three ways, see figure 10.

- i) The TE conveys its packet data on a B-channel. This is circuit-switched via a B-channel across the T reference point to the public ISDN PH.

Note 12:

This case may under utilize the B-channel at the T reference point.

- ii) The TE conveys its packet data on a D-channel which is switched or relayed by one or more SRFs via a D-channel across the T reference point to an FH in the public ISDN. Communication between the FH and the PH in the public ISDN is via a B-channel.

Note 13:

This case could have negative impact on the traffic performance of the D-channel at the T reference point.

- iii) The TE conveys its packet data on a D-channel which is either directly, or indirectly via one or more SRFs, connected to an FH in the PTN. Communication between the FH and the PH in the public ISDN is via a B-channel at the T reference point.

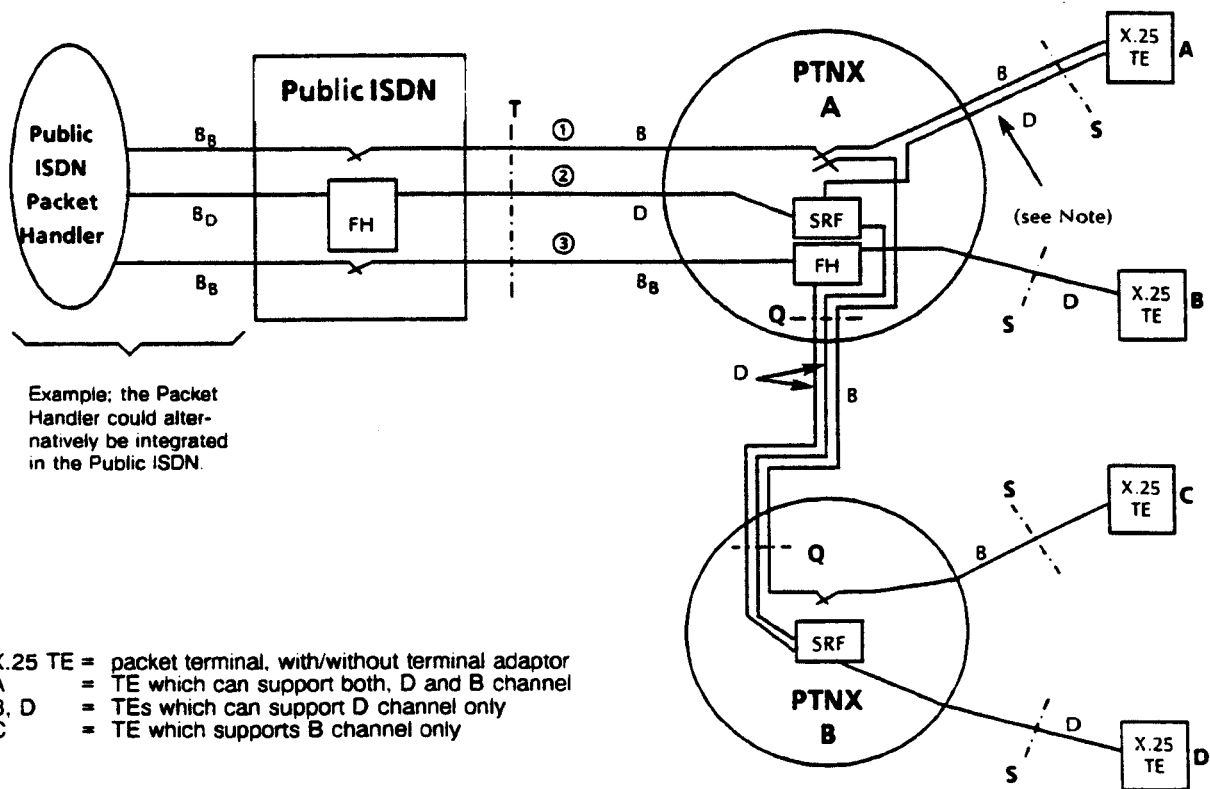

X.25 TE = packet terminal, with/without terminal adaptor
 A = TE which can support both, D and B channel
 B, D = TEs which can support D channel only
 C = TE which supports B channel only

Legend: B_B-channel: A channel at the PH interface used for packet calls provided to a TE on one of its B-channels. Multiple calls to/from the same TE are multiplexed on the same B_B-channel.

B_D-channel: A channel at the PH interface used for packet calls provided to a TE on its D-channel. Multiple calls to/from TEs served by the same SRF are multiplexed on the same B_D-channel.

Note: If the protocol for offering incoming calls to the X.25 TEs does not support the negotiation of a channel type (D or B), TEs supporting communication over both channel types need to have two numbers, each one dedicated to one channel type. This requires the use of the MSN (Multiple Subscriber Number) supplementary service (TE "A").

Figure 10 - Example of a PTN using its Layer 2 Relaying or Switching Function for Accessing a Packet Handler of the Public ISDN (X.31 Case B)

7.5.2.2 PTN with PH

A PH within the PTN can be used as a packet service gateway which connects to the PH of the public ISDN in accordance with X.31 case A or B, or by a direct X.25 or X.75 access circumventing the public ISDN. See figure 11.

X.25 case B can be achieved in two ways:

- i) The PTN PH and the public ISDN PH communicate via a B-channel at the T reference point.
- ii) The PTN PH and the public ISDN PH communicate via an SRF in the PTN, a D-channel at the T reference point and an FH in the public ISDN.

7.6 Interconnected PTNXs

Users of different PTNs can communicate via the public ISDN, thereby using the services which are provided by that public ISDN. These services need not be the same as provided by their PTNs, in fact they may be fewer or less sophisticated. The service provision functions of the PTNXs interwork with corresponding functions residing in the public ISDN. This concept of interconnecting the two gateway PTNXs of the PTNs and thus concatenating the PTN and public ISDN functions is known as the concatenation concept.

For details on service interworking within the concatenation concept see Section 6.

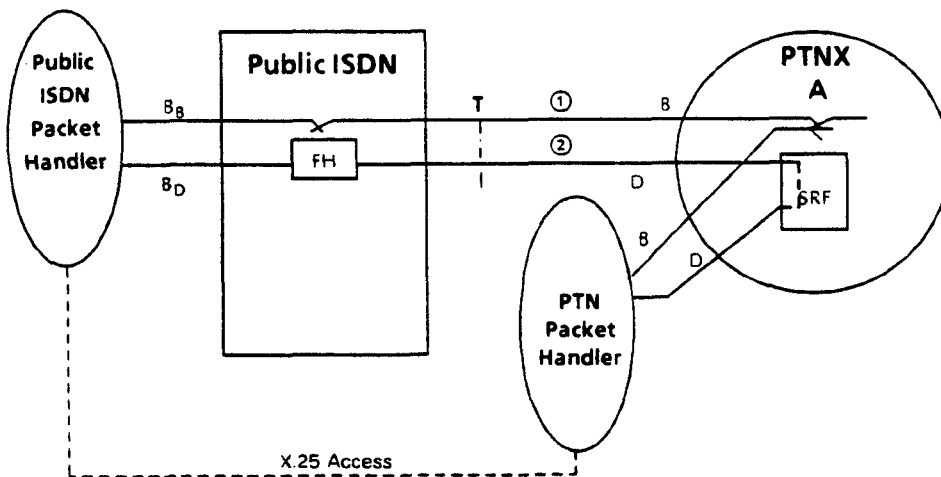

note: Since the calling user need not be aware of the existence of a private PH at the called side, the packet handler of the public ISDN needs to have the knowledge that calls to ISDN numbers of the PTN users are to be routed to the collective ISDN number(s) of the private PH(s). The public ISDN PH also needs to transmit the individual ISDN numbers (or X.121 numbers) in the X.25 call request in order to enable the private PH to further progress the call.

Figure 11 - Example of a PTN using its own Packet Handler for Accessing a Packet Handler of the Public ISDN (X.31 Case B or X.25)

Alternatively, PTNXs may functionally be interconnected in a way that any additional PTNX services are, in principle, available to all users of the so formed single or unique PTN. The interconnected PTNXs use the public ISDN (or other type of network) as an IVN. This concept is called the overlay concept.

The difference between the overlay and the concatenation concepts is shown in figure 12.

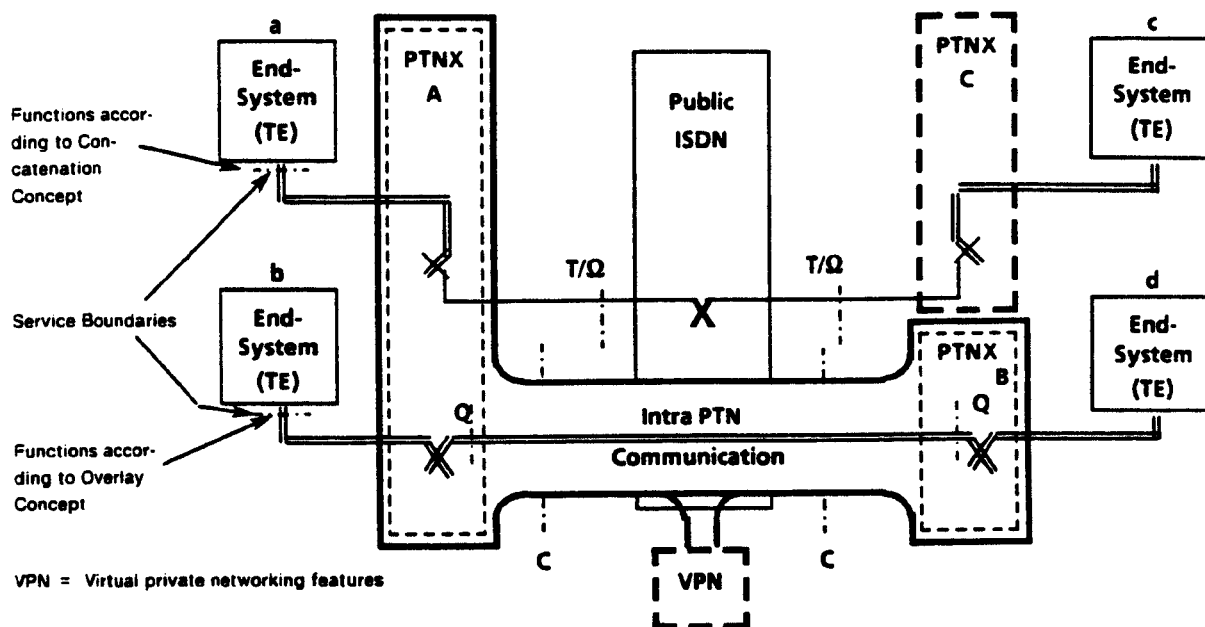

Figure 12 - Relation between the Concatenation Concept and the Overlay Concept

Users b and d in figure 12 have the impression of being connected to one homogenous PTN, i.e. the IVN, in this case the public ISDN, will be invisible to them.

Communication between two PTNXs through the public ISDN according to the concatenation concept does not necessarily permit the two PTNXs to cooperate in the provision of PTN services to their users. Any cooperation is limited by the capabilities of the public ISDN, and therefore the public ISDN becomes visible to the PTN users (e.g. a and c in figure 12). The two PTNXs do not, by virtue of such communication, form a PTN.

It should be studied how PTNXs not belonging to the same PTN, i.e. connected by means of the concatenation concept, can recognize each other's presence and capabilities, in order to provide PTN supplementary services not supported by the public ISDN.

7.6.1 Overlay Concept

In principle, the inter-PTNX connections may be supported by dedicated physical media or transmission media, or by any appropriate kind of bearer services of (public) switching networks. Within the scope of this Clause, the bearer services of intervening public ISDNs are of particular interest.

Two approaches can be distinguished for communication between PTNXs via an intervening public ISDN. Both provide the PTN users connected to separate PTNXs with the same service as if they were connected to one homogenous PTNX: The service of the PTN overlays any service of the public ISDN.

In the transparent approach, the public ISDN provides transparency for the inter-PTNX signalling information to allow the PTNXs to cooperate in the provision of PTN services. The PTN services bypass corresponding services of the public ISDN.

In the integrated approach the intervening public ISDN transposes the PTNX services by means of enhanced capabilities which enable the PTNXs to communicate as if they were interconnected transparently. The technical details of the integrated approach are not covered by this Technical Report.

Various methods are conceivable how to achieve transparency, e.g. a two-step approach of inter-PTNX connections on top of IVN connections, integrated call control and signalling which is supported by VPN features, etc. Although VPN features could be supported by the intervening public ISDN itself, they should be modelled and specified in a way which allows them to be provided by third parties.

The different scenarios (ISDN and non-ISDN based) providing transparent inter-PTNX connections are discussed in Section 3 of this Technical Report. VPN support of a PTN can be modelled on top of the scenarios.

7.6.2 Capability Structure of a PTN Employing IVNs

The overall capability structure of a PTN which spreads over more than one premises and employs a public ISDN as an IVN is shown in figure 13.

The one-to-one mapping between the capabilities of a PTN and the IVN is conceptual only and has been chosen here as an example. It depends on the actual implementation whether an individual capability is supported or not, and it is up to the Interconnection Handling functional grouping, interworking at the PTN side with the IVN, to ensure compatibility as far as achievable. This is either achieved by PTN-to-IVN signalling means, or it needs to be known to the PTN in advance.

Figure 13 - Overall Architecture of a Private Telecommunication Network Employing a Public ISDN as an Intervening Network

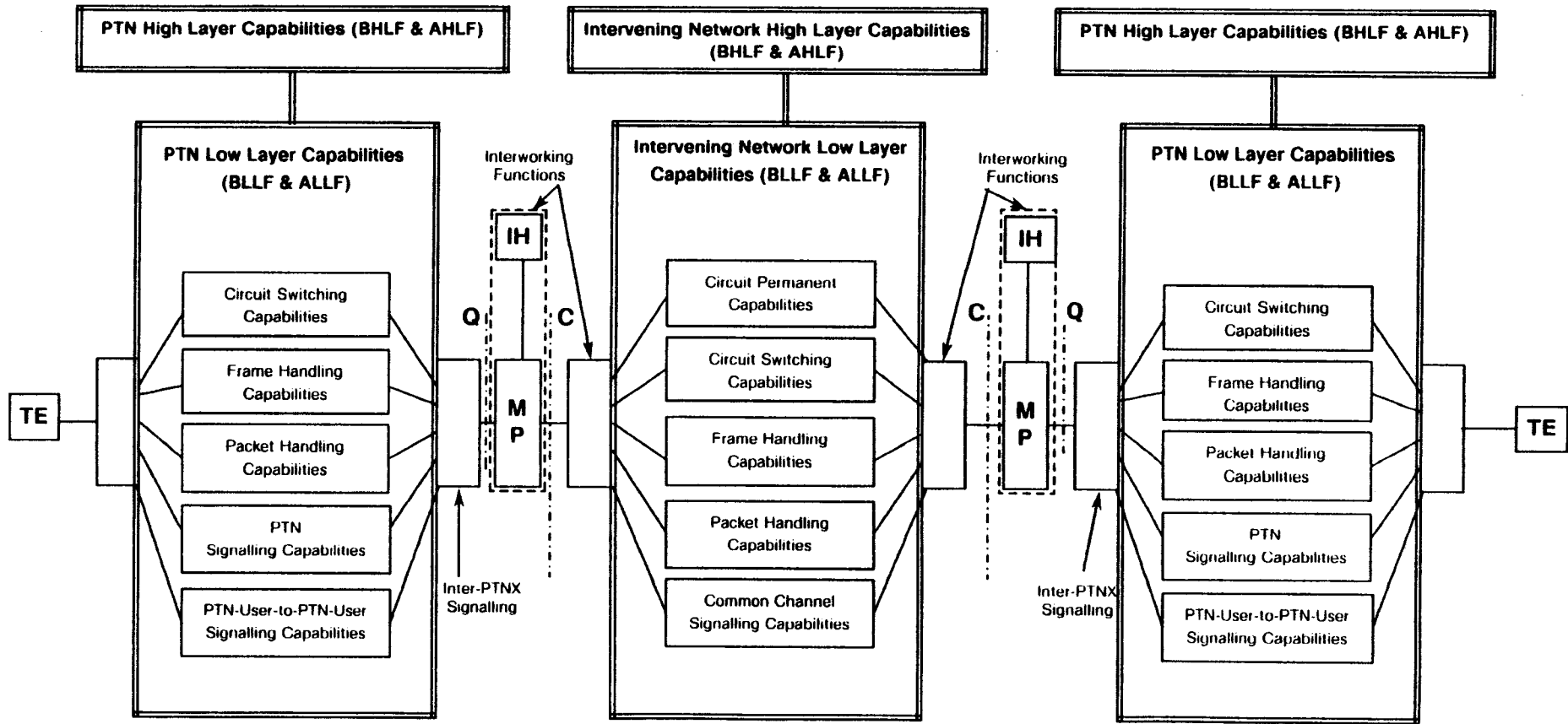

Legend: AHLF = Additional High Layer Functions
BHLF = Basic High Layer Functions

ALLF = Additional Low Layer Functions
BLLF = Basic Low Layer Functions

MP = Mapping Functional Grouping
IH = Interconnection Handling Functional Grouping

8 Extended protocol reference model

Based on the ISDN protocol reference model (CCITT Rec. I.320, excerpt is given in annex B), an extended protocol reference model (EPRM) is used which describes PTNX-interconnection via an intervening public ISDN according to the overlay concept. Other types of IVNs can be described in a similar way.

Figure 14 shows an example of the application of the EPRM to the overlay concept. In Section 3 the EPRM is used to show the impact on protocol architecture when PTNXs are interconnected by various types of IVN.

The EPRM uses the planes described in CCITT Rec. I.320 and some additional planes. The full set of planes is described below.

8.1 Planes for Communication across the IVN

8.1.1 IVN Control Plane (NC)

The NC plane conveys information for the control (e.g. establishment and dis-establishment) of inter-PTNX connections.

8.1.2 IVN User Plane (NU)

The NU plane conveys information between the two PTNXs.

8.2 Planes for Communication across the PTN

8.2.1 PTN Control Plane (PC)

The PC plane conveys PTN signalling information.

The PTNX maps the PC plane onto the NU plane of the IVN.

8.2.2 PTN User Plane (PU)

The PU plane conveys information between PTN users.

The PTNX maps the PU plane onto the NU plane of the IVN.

8.3 Planes for Communication across the PTN Access

8.3.1 TE Control Plane (TC)

The TC plane conveys access signalling information.

8.3.2 TE User Plane (TU)

The TU plane conveys information between PTN users, i.e. user information or user-to-user signalling information.

Note 14:

The TU plane at a PTN access corresponds to the PU plane within the PTN.

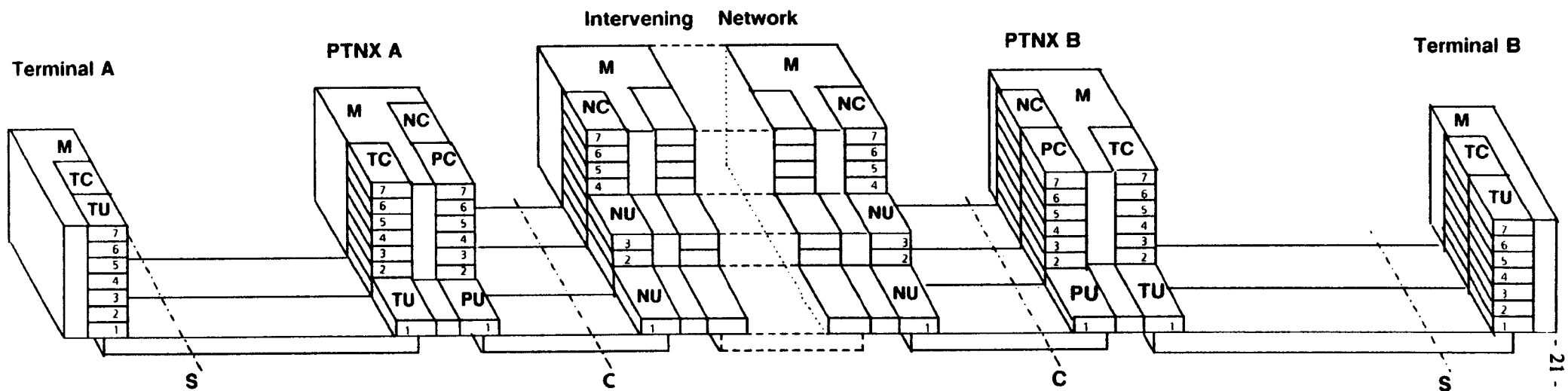

Legend: M Management Entity
S, C S, C reference points

- Notes:
- 1 As an example the NU plane provides a packet mode bearer service via the D-channel supporting the PC plane and a circuit mode bearer service supporting the PU plane.
 - 2 Also as an example, the control planes TC, PC and NC are modelled into 7 layers. Whether for all functions a full 7 layer model is required is not the subject of this Technical Report.
 - 3 For simplicity, the coordination functions between the user plane and the control plane, and the plane mapping functions in the PTNXs, have been omitted.

Figure 14 – Extended Protocol Reference Model

Section 3 - Inter-PTNX Connections

Section 3 of this Technical Report discusses the possibilities for the provision of bearer services for the transparent inter connection of PTNXs forming a PTN according to the overlay concept. Reference solutions are defined and classified which will enable evaluation and harmonization between the provisions of the PTN and those of the third parties.

9 Introduction

In general, a PTN may consist of any number of inter connected PTNXs. For the purpose of studying inter-PTNX connections it is sufficient to consider a configuration consisting of only two PTNXs, as shown in figure 5.

The inter connection media can be

- a physical carrier, or
- an appropriate bearer service

of an IVN; in the latter case the IVN can also be the public ISDN.

Guidelines are given in this Section for the specification of the characteristics and of the provision of such inter connecting media as well as of possible restrictions which might be imposed by some solutions.

Note 15:

Some of the scenarios described in this Section might also be suitable for the support of off-premises PTN users. For further information see annex A.

9.1 Multiple Instances of Q and C Reference Points

This Section focusses on the Q and C reference points as discussed in Section 2.

If a PTNX provides multiple groups of inter-PTNX connections leading to different peer PTNXs, it is considered to employ multiple instances of Q reference points which may be distinguished by appropriate indexes, e.g. Q1, Q2, etc.

The different instances of Q reference points correspond to different instances of C reference points. Depending on the type of IVN, a one-to-one, a one-to-many or a many-to-one correspondance can occur between instances of C reference points and accesses between a PTNX and the IVN(s). This is shown in figure 15.

The use of multiple instances of Q reference points, together with the capabilities of the different IVNs, allows the implementation of any conceivable PTN topology.

9.2 Shared Access Use

Where a public ISDN is employed as an IVN, C and T reference points can exist on the same access(es). This is known as shared access use. Whereas the C reference point enables communication with another PTNX according to the overlay concept, the T reference point enables communication with other public ISDN users and with users of other PTNs. See figure 16.

9.3 Mapping Functional Grouping (MP)

The MP functional grouping provides adaptation functions to the interface at the C reference point and, if applicable, to the IVN control mechanisms.

The MP also provides switching and/or mapping functions of the signalling information at the Q reference point to the appropriate channel or time-slot at the C reference point, depending on the type

of inter-PTNX connection. In the case of intervening ISDNs the inter-PTNX signalling information would be carried on top of Layer 1 in a B-channel or on top of Layer 2 or 3 in a D-channel.

The MP also provides switching or mapping functions from B-channels for user information transfer at the Q reference point to channels or time-slots at the C reference point.

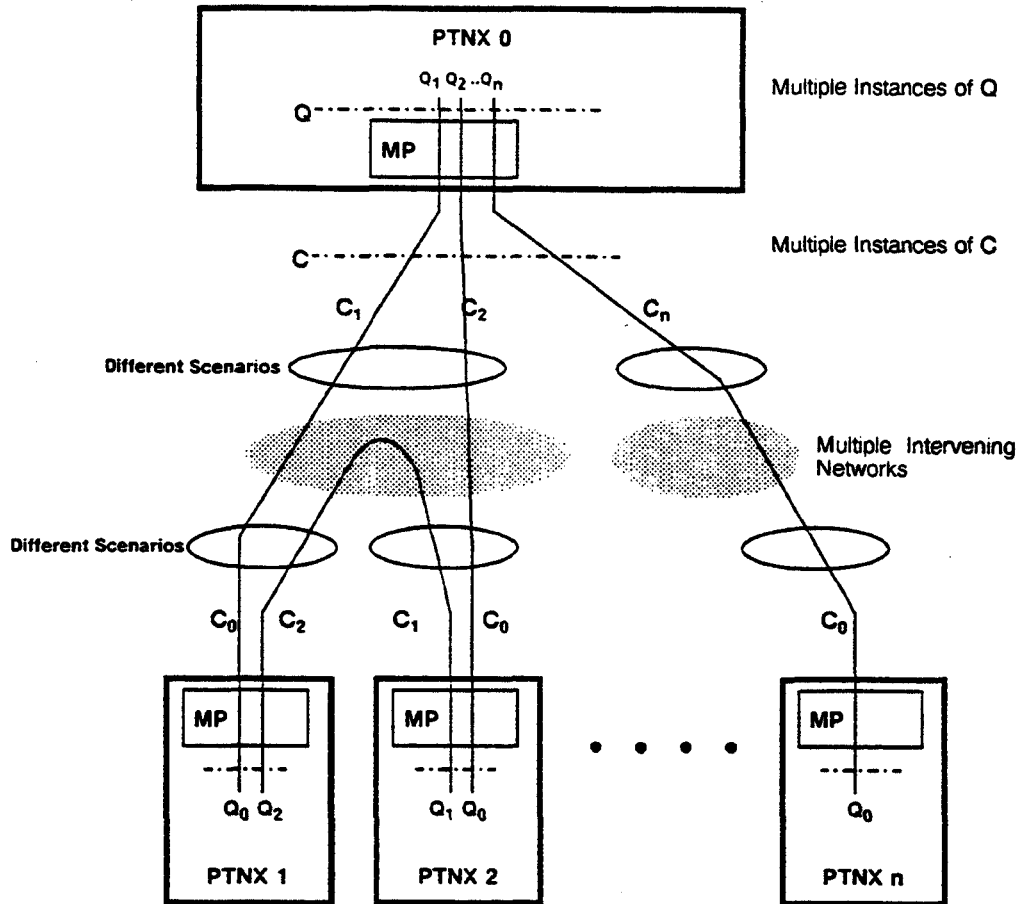

C_i = within the context of a given PTNX, the C reference point for the connection(s) leading to PTNX i.
 Q_i = within the context of a given PTNX, the Q reference point for the connection(s) leading to PTNX i.

Figure 15 - Multiple Instances of Q and C Reference Points

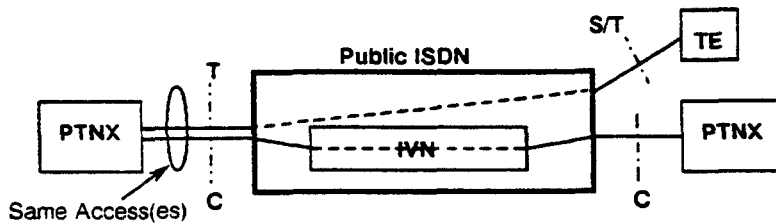

Figure 16 - Shared Access Use

In the case of multiple instances of a Q reference point and/or shared access use, the MP also provides multi plexing functions.

Other possible MP functions, partially depending on the type of inter-PTNX connection, can be:

- address mapping or conversion at and/or between Layers 1, 2 and 3,

- supervision of channels or time-slots for user information transfer,
- inter-PTNX connection establishment and disestablishment,
- end-to-end channel negotiation and/or indication,

The MP functions are strongly related to and rely upon the PTNX management entity.

10 Scenarios

The classification of scenarios described here is given in ENV41006 (which is based on ECMA-135).

For each Scenario two PTNXs with their MP functional groupings, the Q and C reference points and the IVN are shown. For simplicity, the INT functional grouping has been omitted.

Each Scenario describes a generic combination of a method of providing a user information connection and of a method of providing an inter-PTNX signalling connection. Other combinations of these methods may also be applicable, and the classification given here is not intended to exclude them.

Also shown is the relationship between (virtual) B and D-channels at the Q reference point and, if applicable, (real) B and D-channels at the C reference point.

Note 16:

For all Scenarios using a public ISDN the D-channel of an access to the intervening public ISDN, and any B-channel not being used for inter-PTNX connection, may also be used to access services of the public ISDN for purposes other than inter-PTNX connection.

Where applicable, the presentation of a third PTNX explicitly indicates that the Scenario can support multiple instances of Q reference points across a single IVN access. For simplicity, shared access use is not shown.

The following generic combinations have been identified as scenarios.

10.1 Type 1 Scenarios: Dedicated Systems

The inter-PTNX connections are pre-established and do not allow multiple physical destinations. The dedicated Systems encompass dedicated physical links and dedicated transmission systems.

10.1.1 Scenario 1.1 - Dedicated Physical Link

In this Scenario a dedicated physical link, e.g. copper wires or optical fibres, interconnects two PTNXs, see figure 17.

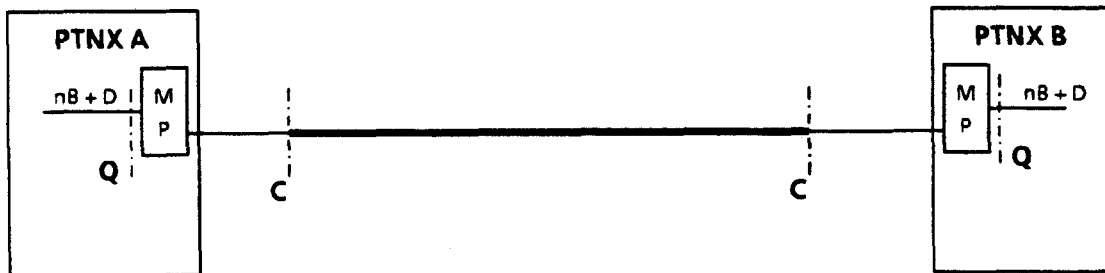

Figure 17 - Dedicated Physical Link

Note 17:

PTNXs could be interconnected by using interfaces according to ETS 300 011 or ETS 300 012. However, the functional ranges of these interfaces allow for short distances only, eg. for back-to-back operation of PTNXs (typically ISPBXs only) which are co-sited on the same premises. Therefore, the use of such interfaces is considered outside the scope of this Scenario.

10.1.2 Scenario 1.2 - Dedicated Transmission System

In this Scenario a dedicated transmission system, e.g. PCM 30, interconnects two PTNXs, see figure 18.

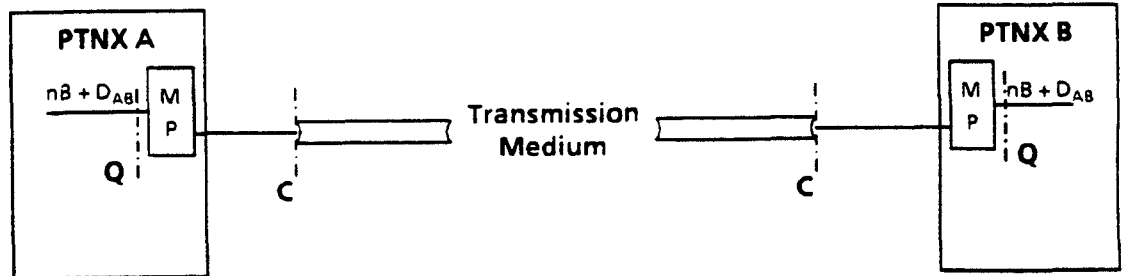

Note: The optional inclusion of IWUs is not explicitly shown.

Figure 18 - Dedicated Transmission System

10.2 Type 2 Scenarios: Permanent IVN Connections

Any number of logical B-channels and logical D-channels is pre-established. Logical B-channels are supported by 64 kbit/s circuit-switched connections. Logical D-channels are supported in the ways described in the following subclauses.

Groups of channels or connections may lead to different destinations.

10.2.1 Scenario 2.1 - Permanent Circuit-Switched

The D-channels of the Q reference point are mapped onto B-channels (or equivalent for non-ISDNs) of the IVN access. These are circuit-switched to other PTNXs, see figure 19.

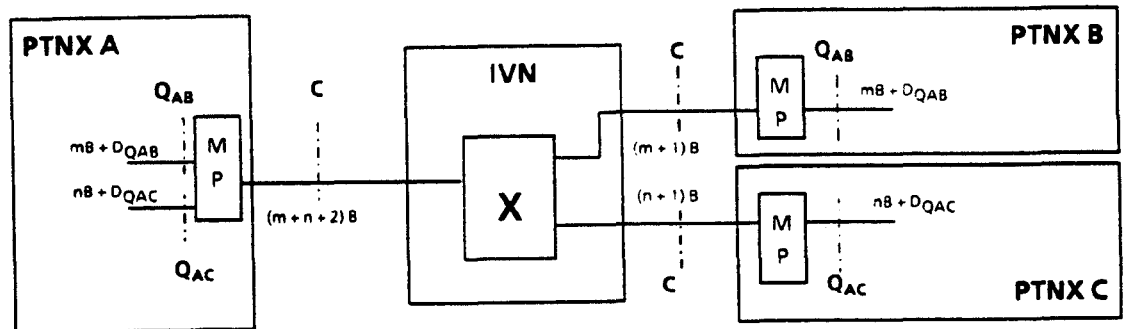

Legend: Q_{AB} indicates a Q reference point which is associated with the interconnection between PTNXs A and B.

Figure 19 - Permanent Circuit-Switched

10.2.2 Scenario 2.2 - Permanent ISDN Signalling

The D-channel at the Q reference point, DQ, is mapped onto a permanent signalling connection within the D-channel at the C reference point. See figure 20.

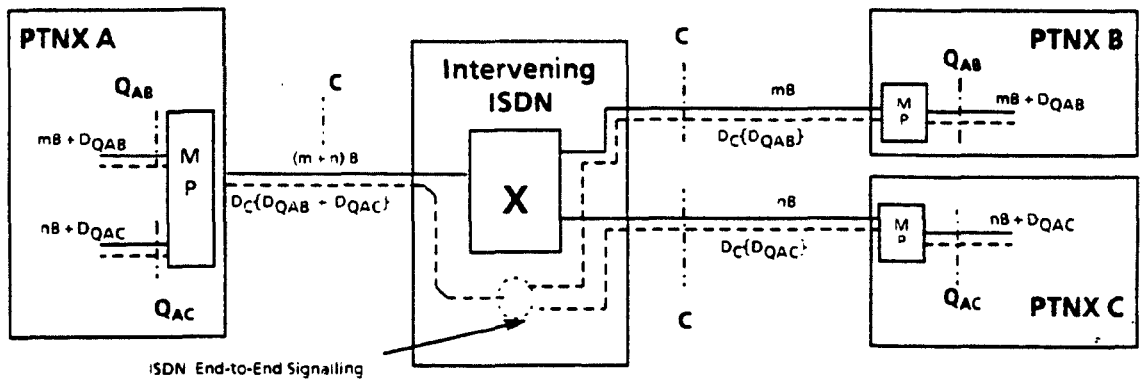

Legend: $D_C\{Q_{AB}\}$ indicates that the D-channel for reference point Q_{AB} is embedded in the D-channel for the C reference point.

Figure 20 - Permanent ISDN Signalling Connection

10.2.3 Scenario 2.3 - Permanent Virtual Call

The D-channel at the Q reference point is carried by a permanent (frame or packet mode) virtual call within a B-channel or the D-channel at the C reference point. See figure 21.

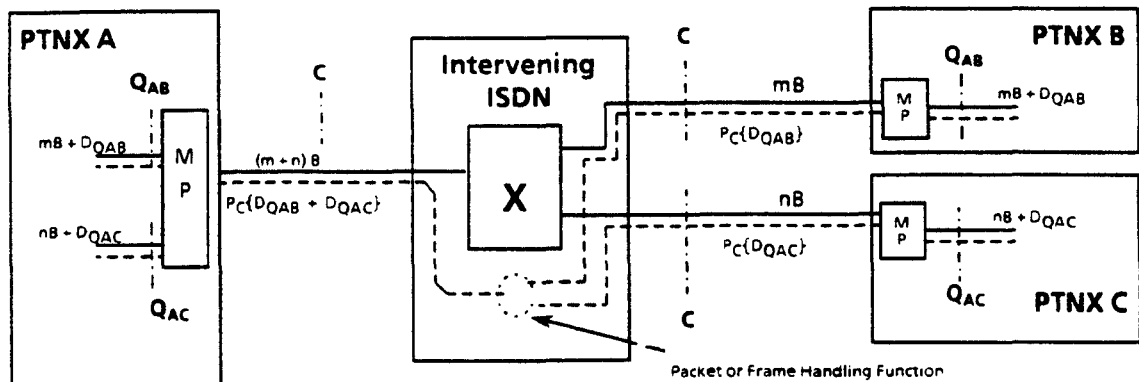

Note: $P_C\{Q_{AB}\}$ indicates that the D-channel for reference point Q_{AB} is embedded in a permanent virtual call which can be conveyed on a B or on a D-channel at the C reference point.

Figure 21 - Permanent Virtual Call

Note 18:

Also non-ISDN based methods are conceivable, but are not explicitly considered in this Technical Report.

10.3 Type 3 Scenarios: On-Demand Public Network Connections

Any number of logical B-channels is established on-demand and a number of logical D-channels is, again, established on-demand or pre-established. Groups of channels or connections may lead to different destinations.

A connection can be established as a direct result of the PTN user's request for call establishment or under management control, e.g. at certain times of a day or during periods of heavy traffic.

10.3.1 Scenario 3.1 - On-Demand Circuit-Switched

The D-channels of the Q reference point are mapped onto B-channels (or equivalent in the case of non-ISDNs) of the IVN access. These are circuit-switched to other PTNX(s). See figure 22.

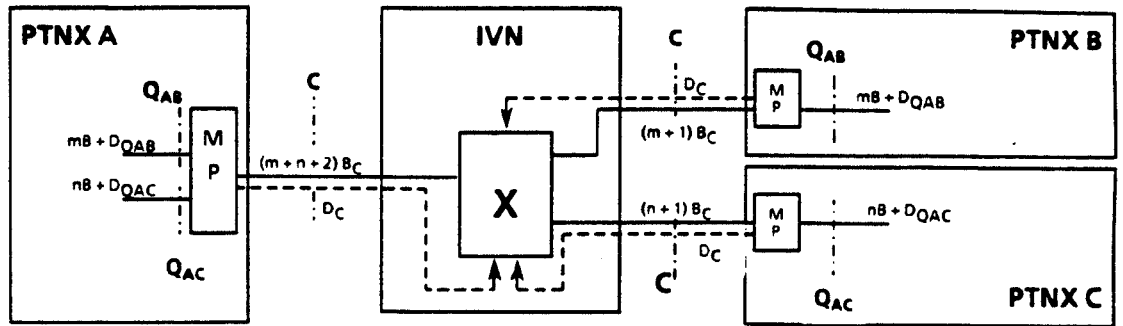

Note: In the case of an ISDN, the C reference points are equivalent to T reference points.

Figure 22 - On-Demand Circuit-Switched

10.3.2 Scenario 3.2 - On-Demand ISDN Signalling Signalling Connection

The D-channel at the Q reference point is mapped onto a temporary signalling connection within the D-channel at the C reference point. See figure 23.

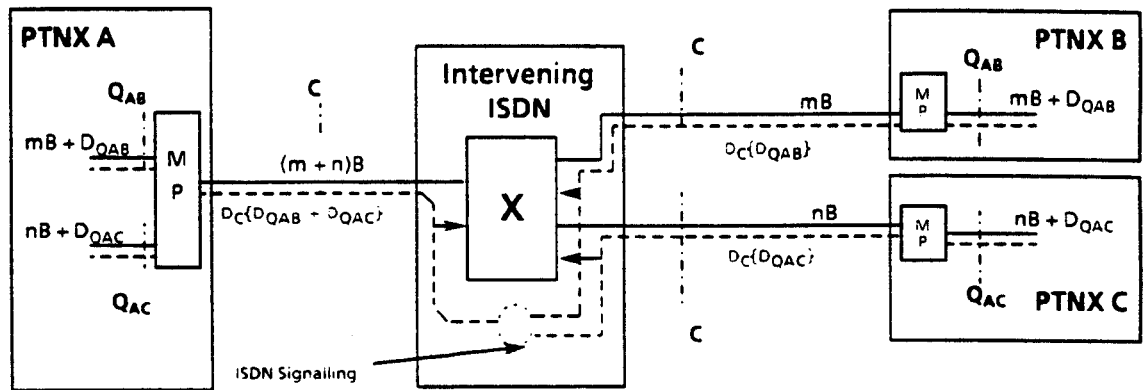

Note: $D_C\{\dots\}$ indicates that the enclosed signalling connection is embedded in the D-channel at the C reference point.

Figure 23 - On-Demand ISDN Signalling

10.3.3 Scenario 3.3 - On-Demand Virtual Call

The D-channel at the Q reference point is carried by a (frame or packet mode) virtual call within the B-channel or D-channel at the C reference point. See figure 24.

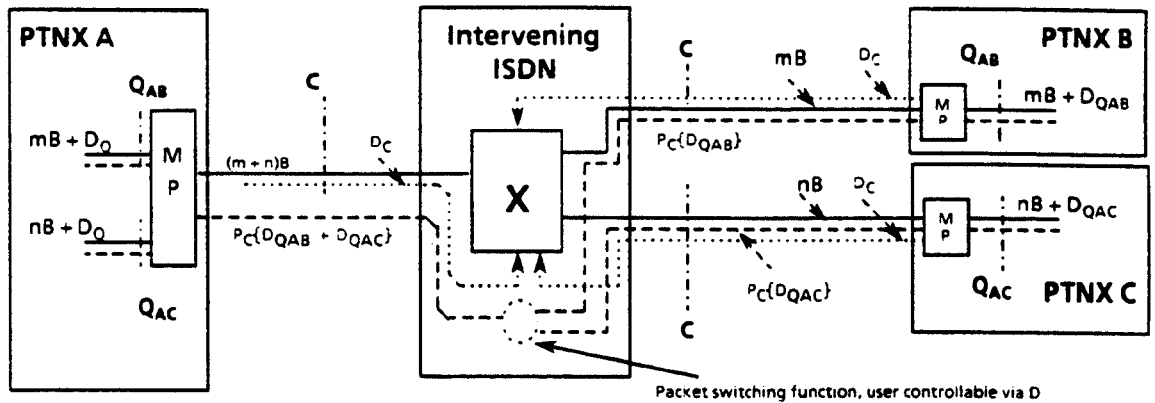

Figure 24 - On-Demand Virtual Call

11 Protocol models

The protocol models describe the intervention level of the IVNs employed for the provision of a particular inter-PTNX connection. The intervention levels help in assessing the behaviour of the corresponding scenario. For simplicity, the terminals connected at the S reference points are not shown in the figures of this clause.

11.1 Scenario 1.1: Dedicated Physical Link

The protocol model for Scenario 1.1 is shown in figure 25.

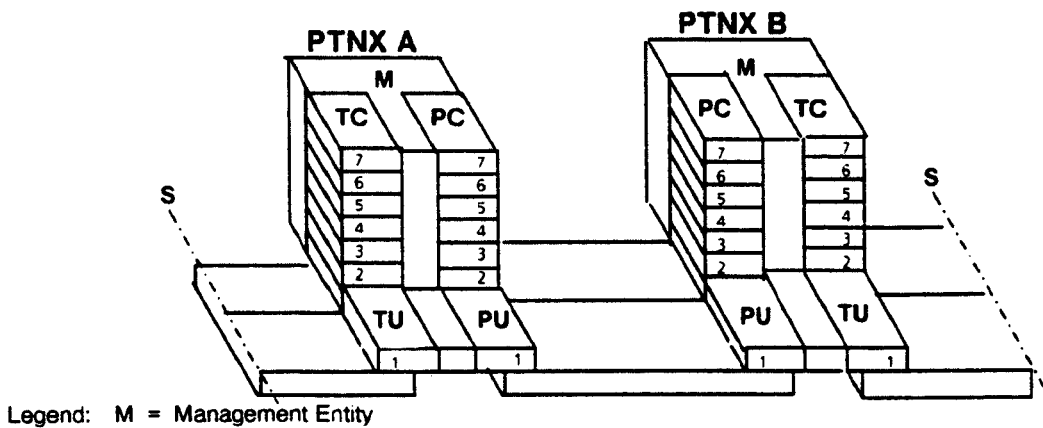

Figure 25 - Protocol Model for the Dedicated Physical Link Scenario

11.2 Scenario 1.2: Dedicated Transmission System

The protocol model for Scenario 1.2 is shown in figure 26.

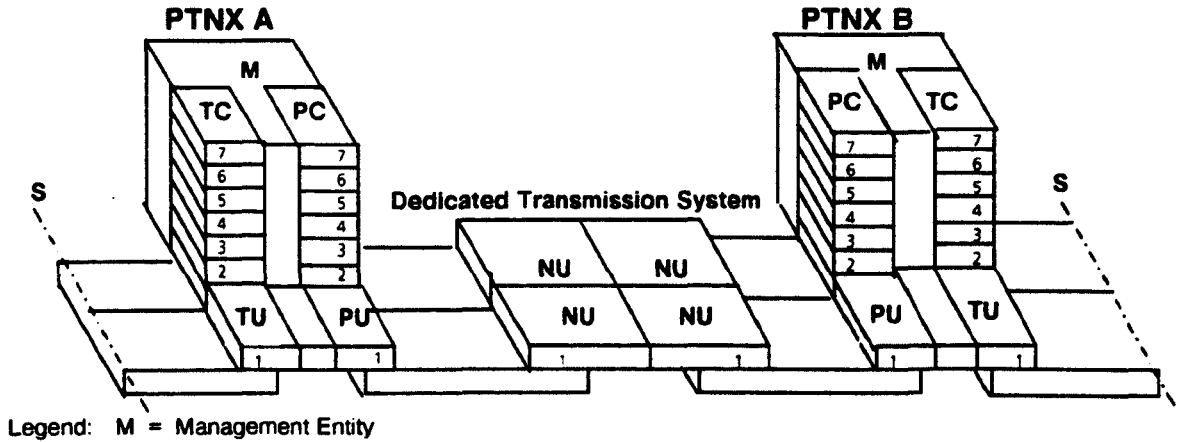

Figure 26 - Protocol Model for the Dedicated Transmission System Scenario

11.3 Scenario 2.1: Permanent Purely Circuit-Switched Connection

The protocol model for Scenario 2.1 is shown in figure 27.

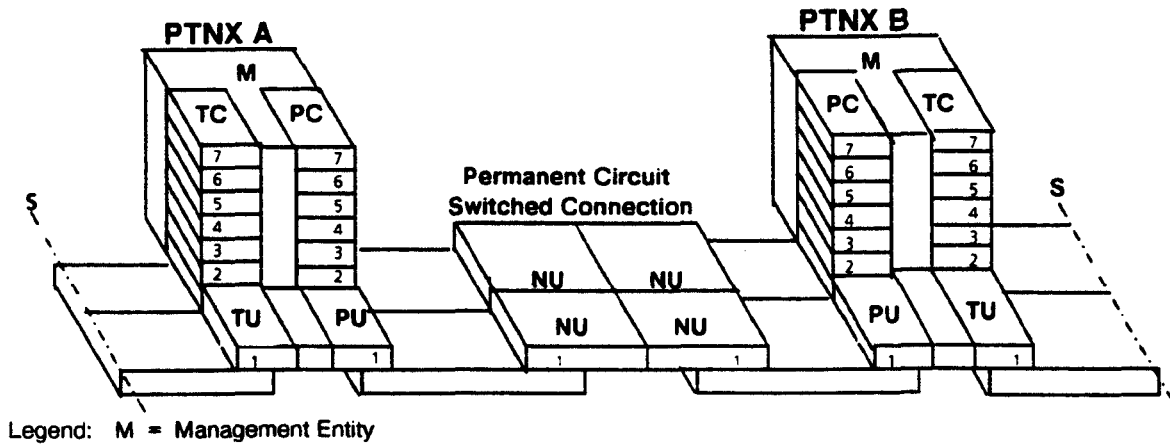

Figure 27 - Protocol Model for the Permanent Purely Circuit-Switched Connection

11.4 Scenario 2.2: Permanent Circuit-Switched/ISDN Signalling Connection

The protocol model for Scenario 2.2 is shown in figure 28.

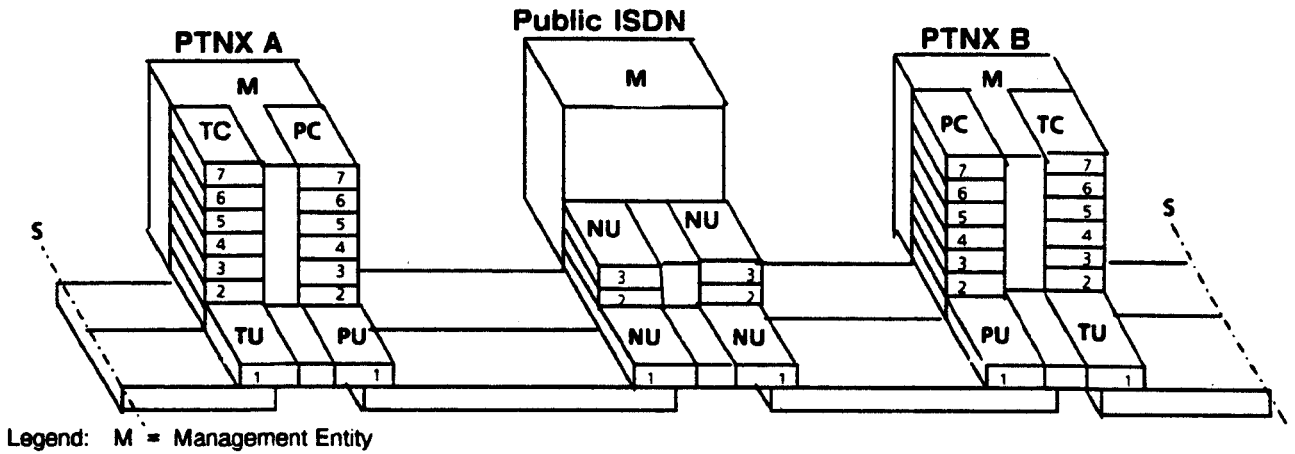

Figure 28 - Protocol Model for the Permanent ISDN Signalling Scenario

11.5 Scenario 2.3: Permanent Circuit-Switched/Packet-Switched Signalling Connection

The protocol model for Scenario 2.3 is shown in figure 29.

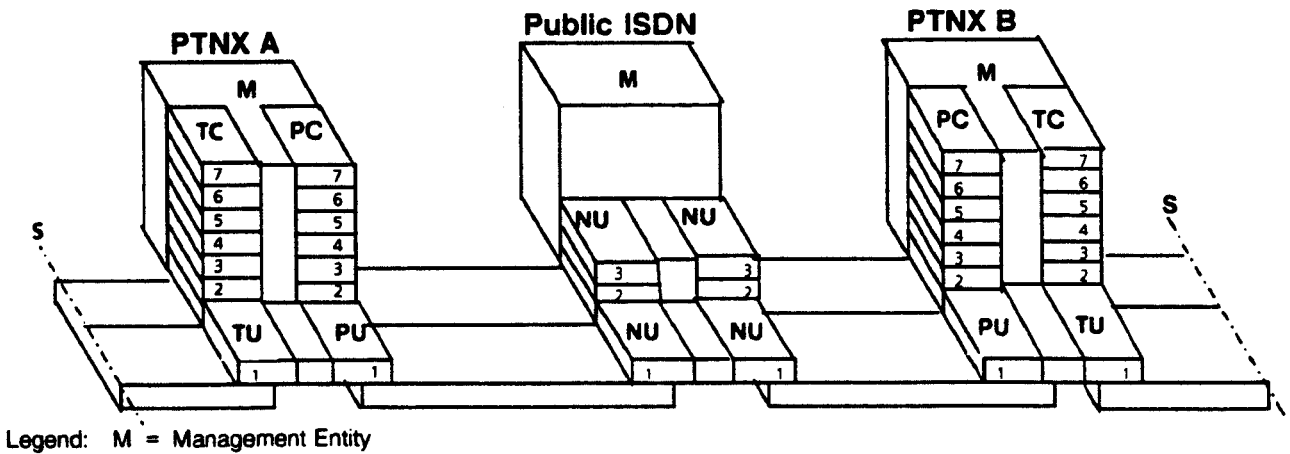
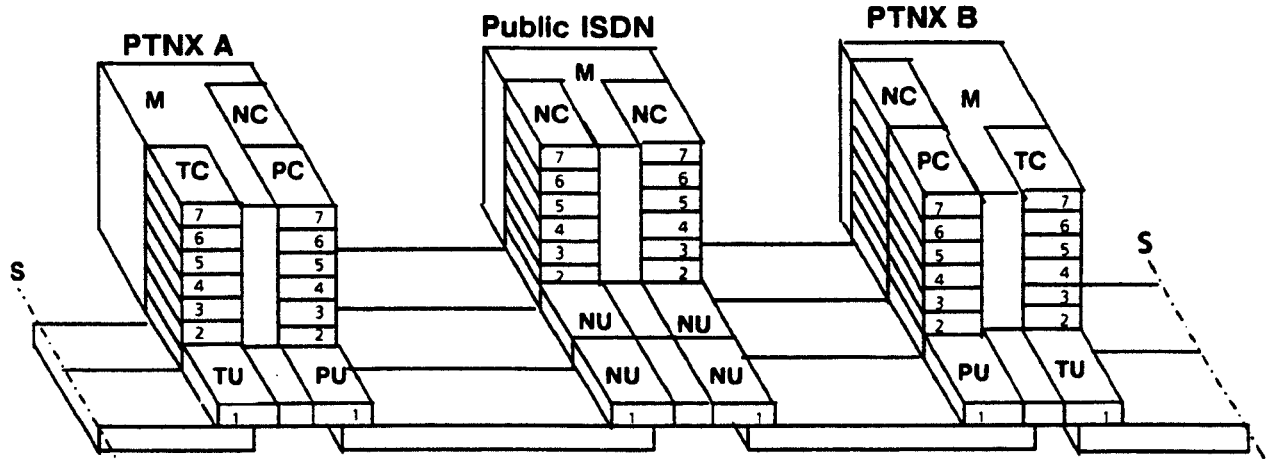

Figure 29 - Protocol Model for Permanent Virtual Call Connection

11.6 Scenario 3.1: On-Demand Pure Circuit-Switched Connection

The protocol model for Scenario 3.1 is shown in figure 30.



Legend: M = Management Entity

Figure 30 - Protocol Model for the Circuit-Switched Link Scenario

11.7 Scenario 3.2: On-Demand Circuit-Switched/ISDN End-to-End Signalling

The protocol model for Scenario 3.2 is shown in figure 31.

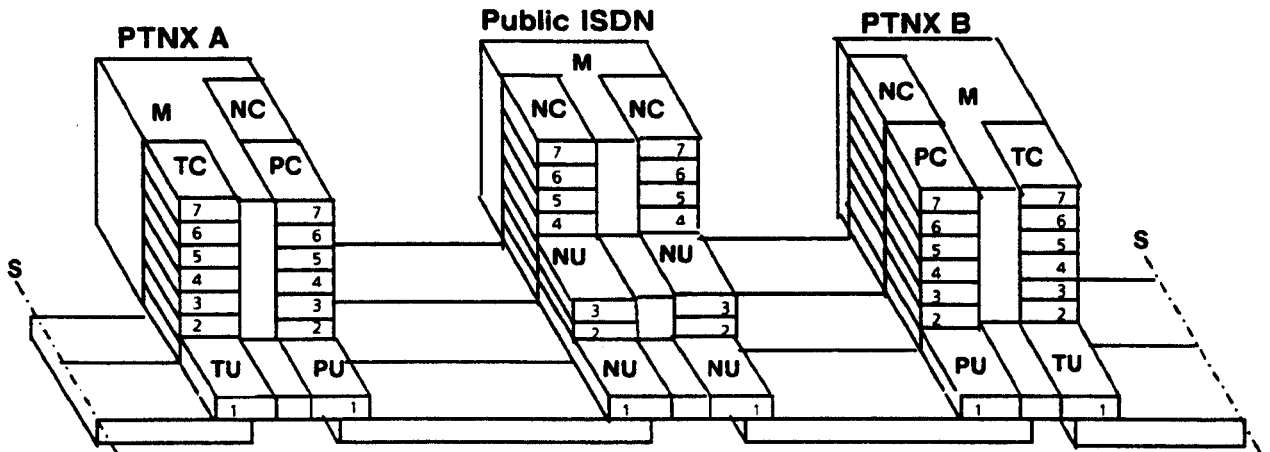

Legend: M = Management Entity

Figure 31 - Protocol Model for On-Demand Circuit-Switched/ISDN End-to-End Signalling

11.8 Scenario 3.3: On-Demand Circuit-Switched/Packet-Switched Signalling Connection

The protocol model for Scenario 3.3 is shown in figure 32.

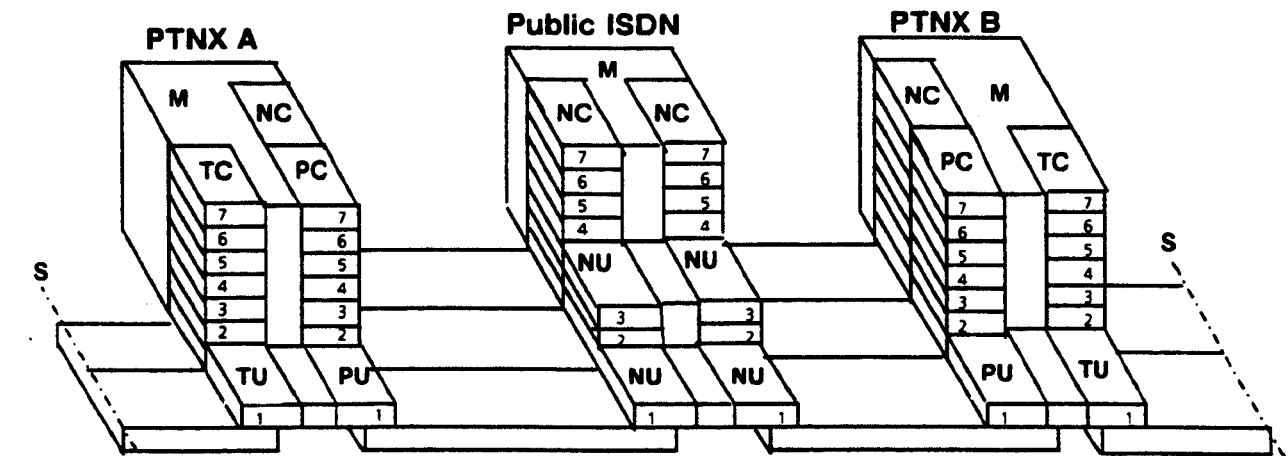

Legend: M = Management Entity

Figure 32 - Protocol Model for On-Demand Virtual Call

12 Evaluation and standardization of scenarios

The evaluation and selection of scenarios for further standardization should be the subject of separate standards or technical reports.

Possible criteria for the selection could be:

- the intervention level of the IVN, which might lead to further sub-criteria, e.g.
 - throughput delay and capacity;
 - signalling transparency, i.e. independency of possible restrictions imposed by the IVN;
- synchronization;
- resilience, e.g.
 - safety against failure;
 - mechanisms for re-establishment of the inter-PTNX connections by the IVN;
 - failure reporting;
 - PTN's ability to discover a failure in the absence of failure reporting;
 - re-establishment of inter-PTNX connections by the PTN;
- impact on obtaining inter-PTNX connections (e.g. administrative actions, subscription);
- configuration flexibility, e.g.
 - shared access use;
 - multiple Q reference points;
 - use of the same access(es) for PTN signalling and for PTN user information.

Section 4 - Addressing

Section 4 of this Technical Report discusses aspects of addressing at the Network Layer of PTNs. It defines strategies for addressing within a PTN and for interworking situations, eg. with the public ISDN and other public or private Networks.

The information provided in this Section should be used to develop a standard on addressing in PTNs which can be used as a common reference document for all addressing related aspects of other standards or technical reports.

13 General

Addresses are the means to identify entities which need to communicate. They are embedded in addressing domains. Within a given addressing domain the addresses are unambiguous.

13.1 Smallest Addressable Entity

Conventional public telecommunication networks are dedicated networks, ie. designed to provide single services typically. Unless other arrangements are made by specific supplementary services, a telecommunication network's addressing domain boundaries coincide with the network's physical boundaries, ie. with its subscriber accesses. There has been no need with these networks to extend the addressing domain from their accesses to a user application level, since typically a one-to-one relationship applies.

The smallest addressable entity in such networks is the user access to the network, corresponding to a terminal (subscriber equipment) which in turn corresponds to a given application, see figure 33.

Note 19:

Typically, telecommunication networks employ addresses which exclusively consist of decimal digits. Thus, the access/application addresses are constrained to numbers and the addressing plans of telecommunication networks are constrained to numbering plans.

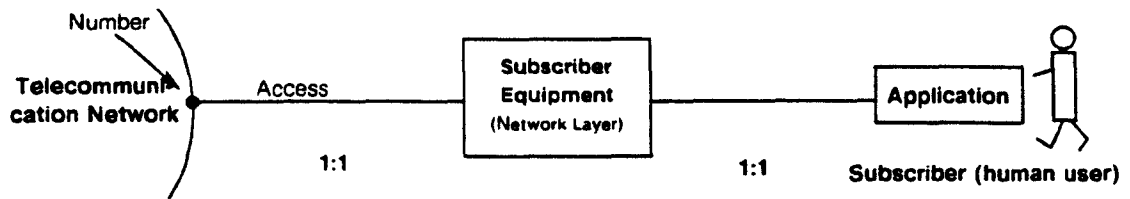

Figure 33 - Smallest Addressable Entity in Conventional Telecommunication Networks

If the one-to-one relation principle within a terminal cannot be maintained (eg., because a bearer service of the telecommunication network is used for multiple applications), the addressing capability needs to be extended in order to allow a mechanism to identify, and to route to, the NSAPs (network layer service access points) in that endsystem. This situation is typical for ISDNs (and PTNs), see figure 34.

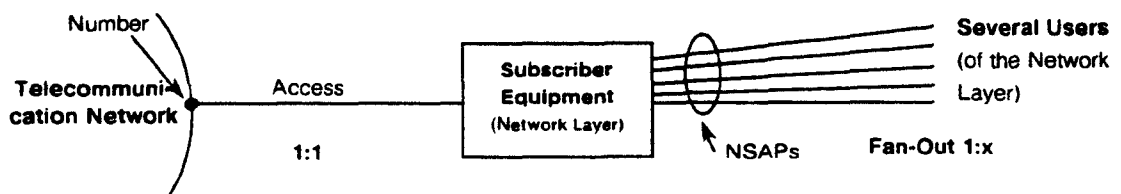

Figure 34 - NSAP Addressing Principle in OSI Endsystems

Such an extended (ISDN or PTN) addressing capability may make use of

- explicit NSAP identification;
- implicit NSAP identification, eg. by means of extended telecommunication network address information of which a significant part will be used in the terminal for NSAP determination;
- higher layer identification by any other means, especially the identification of the Application Layer.

For further information on terminal selection see CCITT Rec. 1.333.

The combined use of these addressing methods leads to the typical addressing situation on an ISDN/PTN basic access, see figure 35.

Note 20:

For PTN primary rate accesses the situation as shown in figure 34 applies.

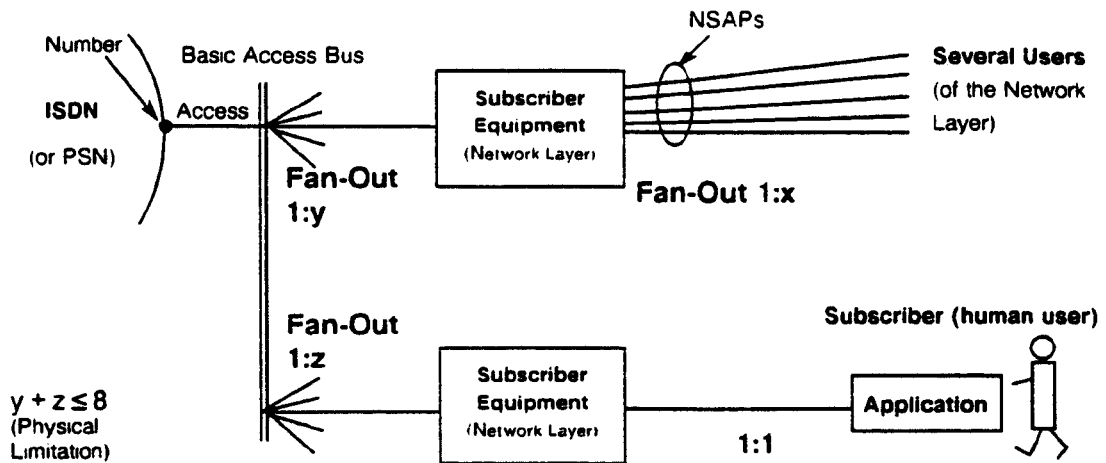
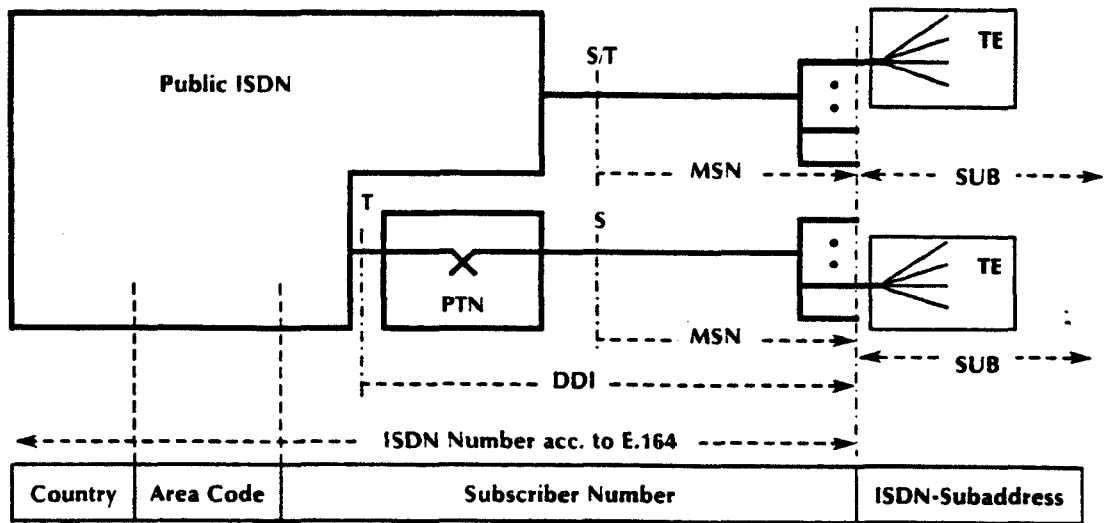

Figure 35 - ISDN/PTN Basic Access Addressing Situation

In the public ISDN the different Fan-Out situations are considered the subject of supplementary services, i.e. Direct-Dialling-In (DDI) and Multiple Subscriber Number (MSN). In addition, the Subaddressing supplementary service (SUB) provides for addressing beyond the ISDN numbering domain. The relationship between the numbering impact of these supplementary services is shown in figure 36.



Legend: DDI = Direct-Dialling-In MSN = Multiple Subscriber Number SUB = Subaddressing

Note: As an example, the Figure shows the relationship at a basic access, where a passive bus allows physical point-to-multipoint configuration and operation. The same principle may, also apply to a primary rate access, where a physical point-to-multipoint configuration is not possible, but a point-to-multipoint operation is still possible.

Figure 36 - Relationship between Direct-Dialling-In, Multiple Subscriber Number and Subaddressing

In PTNs a similar approach should be taken. In neither case (public or private) should the subaddressing capability of the networks be consumed if the addressing requirements can be solved by mere ISDN or PTN numbering solutions.

In PTNs the following addressing related supplementary services of the public ISDN are fundamental, and corresponding PTN functionality should be included in PTN standard(s) on basic services for the reasons given hereafter:

- DDI describes a public ISDN network feature which enables a PTN user to also be addressed by means of public ISDN numbers; from a PTN point of view the of receipt of an incoming call request addressed to a PTN user is a basic interworking function of a PTN with a public ISDN;
- MSN describes the possibility of allocating multiple numbers to a particular access; although the term "subscriber" implies that this is an access of the public ISDN, the same term should be used with regard to a PTN access.
- SUB is considered a much more usual supplementary service in PTNs than in public ISDNs; its inclusion in basic services is a matter of practicality.

13.2 Addressing Principles

ISO has defined a global OSI network addressing principle, see ISO 8348/ADD2.

Beside an addressing scheme for worldwide public addressing, the global OSI network addressing principle provides also for addressing in private domains. For the infrastructure and use of this so called domain specific part different standards are available, e.g. ECMA-117 and MAP.

The global OSI network addressing principle has been taken into account by CCITT when structuring the ISDN numbering plan, see CCITT Rec. E.164.

The overview of all three addressing principles is given in figure 37.

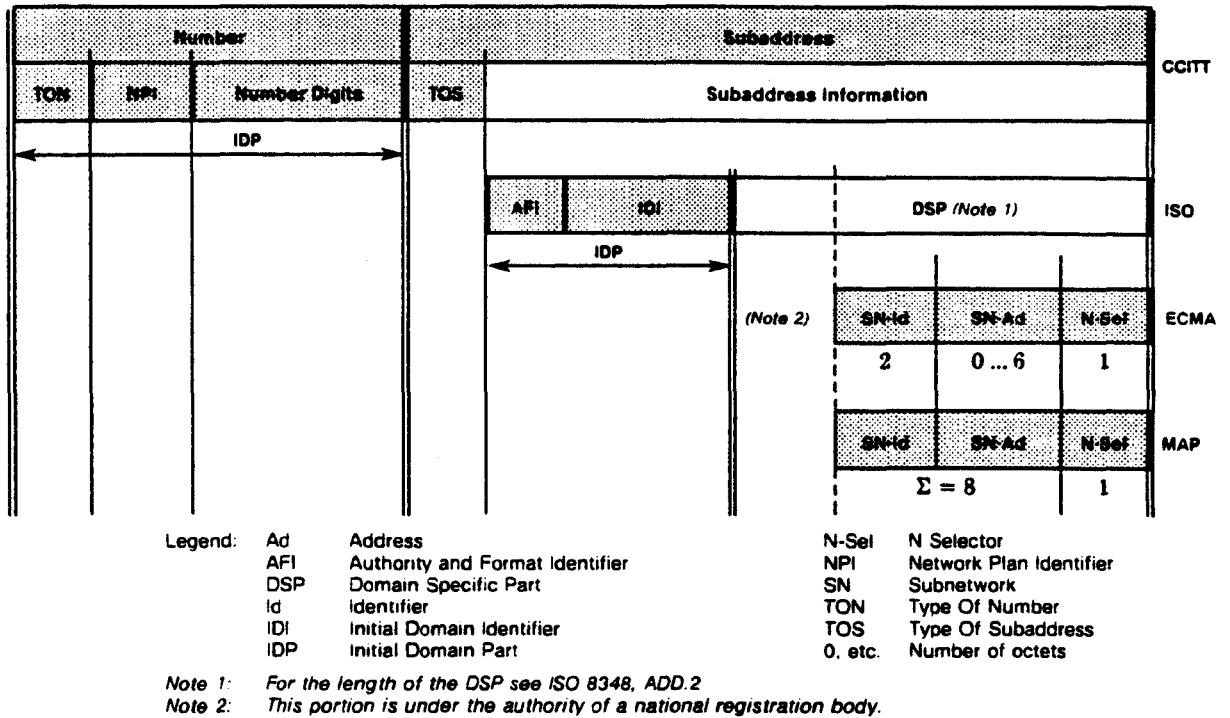

Figure 37 - Addressing Principles

13.2.1 The ISO Global OSI Network Addressing Principle

Several international standards for numbering/addressing exist for the various public networks, namely

- CCITT Rec. X.121 for data networks (packet and circuit-switched)
- CCITT Rec. F.69 for telex networks
- CCITT Rec. E.164 for ISDNs

These public networks are subnetworks in the sense of the OSI Network Service, and their numbering plans are a subset of the global network addressing domain, which contains all network addresses in the OSI environment.

The ISO specification of a global OSI network addressing principle declares the various subnetworks to addressing subdomains and assumes that each subdomain is administered directly by one and only one addressing authority which is authorized by the authority for the higher domain.

In addition to CCITT, ISO has specified two world-wide addressing schemes, which can be used by customers ("enterprises") on a per-country basis (ISO DCC) or on a per organization basis (ISO ICD).

The addressing authority for the global network addressing domain is ISO 8348/ ADD2, specifying the authorities (ISO, CCITT). These authorities are responsible for the first stage subdomains representing themselves by the above mentioned numbering plans.

Beside public addressing subdomains, the global OSI network addressing principle basically includes also private addressing subdomains, as far as they are involved in a global OSI communication.

ISO separates between

- an initial domain part (IDP) reflecting the public addressing subdomain and

- a domain specific part (DSP) reflecting the private addressing subdomain.

The IDP is composed of an authority and format identifier (AFI) and an initial domain identifier (IDI). The AFI specifies

- the network addressing authority responsible for allocating the IDI values,
- the format of the IDI and
- the abstract syntax of the DSP.

The IDI specifies

- the network addressing authority responsible for allocating the DSP values and
- the network addressing domain to which the DSP values are allocated.

The semantic of the DSP is determined by the network addressing authority identified by the IDI. A further substructure of the DSP may or may not be defined by this authority.

13.2.2 The CCITT ISDN Addressing Principle

CCITT has based its definitions for the ISDN numbering principle on the Global OSI Network Addressing Principle. The definitions are reflected in various CCITT Recommendations., eg. I.330, E.164, Q.931.

Basically, the ISDN numbering principle focusses on the IDP. In addition to the AFI (which in the ISDN terminology is called numbering plan identity, NPI), CCITT introduces the type of number (TON). This is due to the fact that within the conventional telephony service (supposed to play also a dominant role in the ISDN) "abbreviated" numbers are very common, eg. local "subscriber" numbers. Thus, the ISDN numbering principle provides information on

- the type of number (TON),
- the numbering plan identity (NPI),
- the number itself (number digits).

Note 21:

Whereas ISO has assigned AFIs to the CCITT numbering plans and thus allows for transition from an ISO addressing domain to a CCITT addressing domain, CCITT has not provided mechanisms for the opposite direction.

CCITT allows for an additional use of ISO addresses only by offering to carry subaddresses, with a net content of up to 20 octets. Similar to the number, the subaddress consists of a type of subaddress (TOS, indicating whether the subaddress information is an NSAP address or not) and the subaddress information itself. The latter is not defined to any more detail by CCITT.

The capacity of the subaddress is intended to accommodate the global OSI network address including the DSP, if present.

13.2.3 The Domain Specific Part Addressing Principles

The internal structure of a private addressing domain may be of considerable complexity, including several subnetworks interconnected by internal gateways. The two standards, ECMA-117 and MAP, specify a way for structuring the Domain Specific Part (DSP) of Network Layer Addresses by the authority responsible for the administration of a private addressing domain of the OSI network, thus facilitating interconnection of multi-vendor equipment.

The highest permissible length of the DSP, common to all syntaxes permitted by ISO 8348/ADD 2 and supported by the CCITT ISDN numbering principle, is 9 octets for binary syntax, or 23 digits for decimal syntax. The binary syntax is preferred.

The main difference between the MAP and the ECMA-117 defined structure of the DSP is the higher flexibility of MAP in

- partitioning the DSP between subnet-ID and subnet-Address and
- hierarchically structuring the subnet-ID.

13.2.3.1 The ECMA Addressing Principles

ECMA-117 defines a DSP structure with the following components:

- Subnetwork Identification (SN-ID):

This component provides the means to identify a particular subnetwork within a private domain.

The length of the Subnet-ID is fixed to 2 octets for binary or 5 digits (maximum 65534) for decimal DSP syntax. Within these length constraints it is not possible to allocate globally unique subnetwork identifications. Global uniqueness of network addresses results only from the linkage with the IDP portion of the address.

The Subnet-ID with both octets set to '00' (00000 in the decimal syntax case) is reserved to indicate that no subnetwork is identified explicitly in the private domain, so that routing can be done using the subnetwork address only (e.g. within a single LAN).

The Subnet-ID with both octets set to 'FF' (99999 in the decimal syntax case) is reserved to indicate that the remainder of the DSP is in a private format.

- Subnetwork Address (SN-Ad):

This component provides the means to address particular points of attachment to the subnetwork (SNPA). It must allow for conveying the actual addresses used by the subnetwork, such as ISO 8348/ADD 2 addresses and X.121 addresses.

Therefore ECMA-117 allows a maximum length of 6 octets in the binary syntax case, or 15 digits in the decimal syntax case.

Instead of actual subnetwork addresses, "synonyms" or "logical values" may be used in some cases, such as multiple attachment to one or more subnetworks.

- NSAP Selector:

This component identifies a particular NSAP which can be accessed through the particular subnetwork point of attachment (in end-systems with more than one NSAP).

The length of the NSAP Selector is limited to 1 octet in the binary syntax case or 3 digits (maximum value 255) in the decimal syntax case.

A value greater than 127 is defined to indicate that the associated subnetwork address is to be treated as a synonym.

13.2.3.2 The MAP Addressing Principles

MAP defines a DSP structure which is based on considerations simplifying routing. Thus, routing is divided into three basic levels:

- Routing between different "enterprises",
- Routing between (logical) subnetworks within an enterprise domain (Intermediate System-to-Intermediate System), and
- Routing between End Systems (ES) and either Intermediate Systems or other End Systems (ES - IS routing).

This results in a three-level NSAP address structure:

- the Enterprise ID identifies an enterprise and maps to the IDP of the NSAP address as defined in ISO 8348/ADD2 . With certain AFIs (eg. ISO DCC) also parts of the DSP can be utilized to identify the enterprise ("Organization ID").

All AFIs of ISO 8348/ADD 2 are supported.

- the logical Subnetwork ID identifies a subnetwork within an enterprise and may be structured hierarchically, thus allowing for grouping of subnetworks into Areas, Sub-Areas etc.
- the Subnetwork Address identifies an End-System within the subnetwork.

13.3 Purpose of Addresses

13.3.1 Selection

A selection address or number is used for intra-network purposes, ie. for routing through the domain and, if applicable, through subsequent domains. The user who requests communication supplies a selection address or number and is responsible for its correctness.

13.3.2 Identification

An identification address or number identifies a user involved in a communication. It can, subject to possible restrictions, be presented to other users in order to allow for the execution of subsequent tasks, eg. access control, reverse calls, etc. The responsibility for the correctness of this type of information differs between ISDN/PTN and OSI addressing principles.

13.3.2.1 Identification according to the ISDN/PTN Addressing Principle

ISDN basic access terminals are, in general, assumed to be physically interchangeable meaning that they can be moved from network to network, eg. from the public ISDN to a PTN and vice versa, or from one PTN to another PTN. The basic call description for the public ISDN does not provide any management transaction by which the ISDN terminal could obtain its number from the ISDN on a per call basis.

Consequently, the terminal in general does not have

- any awareness of its actual ISDN number, nor
- any knowledge of the numbering plan it is actually operating with, eg. ISDN.

Therefore the identification number is supplied by the public ISDN, which is responsible for its correctness.

However, in the context of the MSN supplementary service, a terminal might be required to provide information indicating which of the possible numbers applies.

Similar principles should be adopted for identification numbers in PTNs. Further details should be defined in a standard on addressing in PTNs.

A network receiving an identification number from another network does not have responsibility for its correctness. In particular, a public ISDN receiving an identification number from a PTN should be able to by-pass any screening which it would perform when receiving information from a terminal.

For further information on the necessity for non-screening see annex C.

13.3.2.2 Identification according to the OSI Addressing Principle

The OSI network service definition demands the exchange of the identification information of the respective users across the Transport-to-Network Layer boundary. It does not imply that each endsystem knows its own identity. The identification address may be provided as a network layer

service. However, most of the current implementations are based on the user's knowledge of his own identification address.

If an OSI endsystem wants to retain a specific Network Layer address (which might have been agreed upon on a long term basis with another OSI endsystem, eg. between data terminal and its host) independently of its actual ISDN number, it will have to establish this identification address as its OSI NSAP address. This identification address can then be conveyed as a subaddress through the public ISDN or PTN, in addition to the ISDN number.

13.4 Address Interworking

When calling and called entities do not reside in the same addressing domain, address inter working becomes necessary. The global OSI network as well as the ISDN addressing principle are based on a (worldwide) knowledge of addressing domains. Whether this is valid for every interworking situation should be investigated.

If this knowledge is not available, the "port tech nique" will have to be employed. The selection address or number will have to explicitly identify the port of entry to the subsequent domain. The more domains that have to be traversed, the more sets of address information need to be concatenated.

The domain specific parts of the selection address or number have to be transparently con veyed through each "foreign" addressing domain. The provision of the necessary transport capacity may cause problems.

In a similar way, also identification addresses or numbers will consist of concatenated domain specific information.

13.5 Address Values of the Public ISDN Addressing Domain

CCITT distinguishes between ISDN numbers and ISDN addresses. It is the ISDN number which fully identifies the addressable entities of the Public ISDN addressing domain.

Note 22:

The term ISDN address designates the concatenation of ISDN number and ISDN subaddress. It thus identifies entities which are explicitly outside the ISDN ad dres sing domain. From a terminology point of view, this definition is more confusing than clarifying. Its use is therefore avoided in this Technical Report.

The values of ISDN numbers are defined in the ISDN numbering plan, see CCITT Rec. E.164.

The ISDN number consists of a sequence of decimal digits, 0, 1, 2...9. Whether also the characters *, #, A, B, C, D shall be used in an ISDN number should be defined.

13.6 Addressing Principles in LANs

The specific example of LAN-PTN interworking is kept outside the scope of this Technical Report, and left for further study.

14 PTN Numbering Concept

PTNs are part of the so called Wide Area Networks (WANs). This allows the endsystems con nected to them to communicate with global networks, in particular with the public ISDN. The global public ISDN employs a numbering plan, i.e. the addresses used in its addressing do main are numbers. Due to terminal interchangeability between PTNs and public ISDNs also a PTN should employ a numbering plan.

14.1 Numbering Plans of PTNs

A PTN typically follows the ISDN addressing principle, see 13.2.2. Within this context, the PTN may use either the ISDN Numbering plan itself or, alternatively or in addition, a dedicated private numbering plan (PNP). This situation is shown in more detail in figure 38.

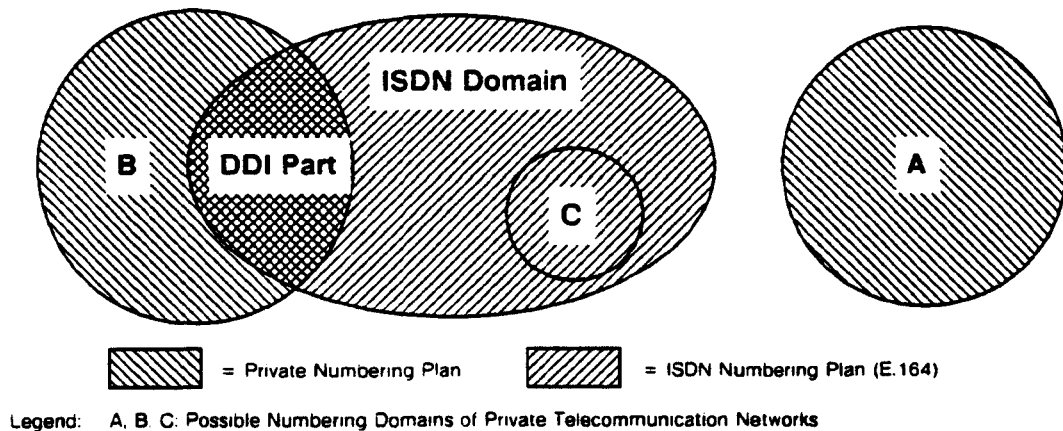

Figure 38 - Employment of the PNP and/or the ISDN Numbering Plan as PTN NPs

Domain A employs a PNP exclusively, which means that this domain does not provide any addressable entity that could be directly addressed from the public ISDN.

Domain B employs a PNP and the ISDN numbering plan, such that each addressable entity within the double-shaded area has a number from each numbering plan.

Note 23:

In the extreme, all addressable entities in a domain can have a number from each numbering plan.

Domain C employs the ISDN numbering plan exclusively, which means that no addressable entity can be operated in this domain with a number of a significance different from that of the ISDN NP. Although such a restriction is conceivable in theory, it is very unlikely in practice, since such a concept would preclude also any private network specific or abbreviated number.

Assuming that a PTN typically is connected to the public ISDN via its DDI supplementary service, or that, if not so, the PTN Authority may choose at any time to have DDI provided, a PTN will have to be prepared to conform to two numbering plans in parallel, namely:

- its own PNP which, in principle, allows the use of the same digits or digit sequences as in the public ISDN, however, with a different significance, and
- the numbering plan of the public ISDN.

Note 24:

The number of addressable entities need not be the same in the two numbering plans.

Interworking between both numbering plans will be simplified if the PNP number digits form a subset of the ISDN number digits, i.e. when the last significant digits of both numbers are identical. Otherwise, mapping between the PTN and the public ISDN numbering plan will be more complex and will require the PTN users to publish both numbers separately for intra-PTN and for public ISDN communication.

Within the scope of this Technical Report the combination of

- the CCITT defined ISDN numbering principle, especially the enhancement for private numbering plans,
- the OSI addressing principle,
- and, if applicable within a private domain, of either or both
 - the ECMA definition and addressing principle and
 - the MAP definition and addressing principle,

are to be covered by the PTN addressing concept.

14.2 Private Numbering Plan Structure

As for the ISDN numbering plan it should be possible to organize a PNP hierarchically so that shortened forms of PTN numbers can be used in certain parts of a PTN. This will then lead to a PNP structure as indicated in table 2. For the purpose of comparability, also the structure of the public ISDN numbering plan is shown.

Table 2 - Structure of the Private and Public ISDN Numbering Plans

Explicit Format	
NPI = E.164	NPI = PNP
-	Level 3 Regional Number
International Number	Level 2 Regional Number
National Number	Level 1 Regional Number
Subscriber Number	Local Number
Partial	Partial
Unknown	Unknown
Network specific Number	PTN specific Number
Abbreviated Number	Abbreviated Number

14.3 Content of the Number Information in a Private Numbering Plan

A PNP number should comprise a sequence of decimal digits with the possibility that different numbers within the same PNP can have different lengths. The maximum length and the minimum length to be supported by a PNP should be specified in the addressing standard.

14.4 Reference Configuration for PTN Address Treatment

The addressing principles to be adhered to in PTNs can best be determined by studying the requirements for typical connections through a PTN, i.e. for selection numbers and for originating and destination identification numbers.

Figure 39 shows a reference configuration, in which such typical connections are depicted for selection numbers. Similar reference configurations apply for originating and destination identification numbers.

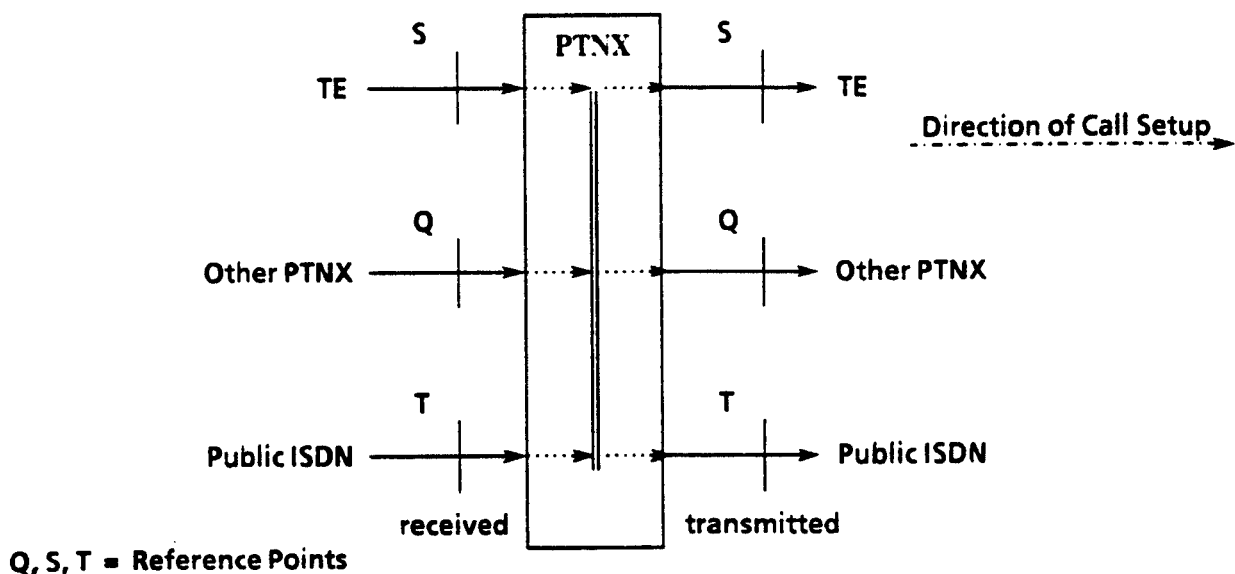

Figure 39 - Numbering Formats for Selection Numbers

The figure shows a PTNX to which two TEs are connected via interfaces at an S reference point. Further, the PTNX is connected to a public ISDN via two interfaces at the T reference point, and to other PTNXs via two Q reference points. For the purpose of this model, the connections are used unidirectionally.

14.5 Knowledge about other Numbering Plans

For interworking with foreign addressing domains (e.g. under ISO or CCITT authority) the following approaches can be used:

- i) The address information explicitly indicates the foreign domain by the appropriate AFI/NPI. As far as selection address information is concerned, the responsible network layer entities have to have the necessary knowledge to derive the routing information.
- ii) The address information implicitly indicates the foreign domain by, e.g., prefixes or numbers of the PTN or ISDN numbering plan, depending on which network the foreign domain is attached to.
- iii) The address information indicates by means of a PNP or ISDN number a gateway to the foreign domain. Further address information (applicable within the foreign domain) needs to be conveyed as subaddress information in the PTN (or public ISDN, if applicable).

It should be studied which NPI values other than "ISDN" and "Private" should be supported by a PTN.

15 Support of subaddressing in PTNs

This clause shows which type of information can be conveyed in subaddresses. The actual use of subaddresses for specific applications is outside the scope of this Technical Report.

15.1 Embedment of OSI Network Layer Addresses in Concatenated PTN Addressing Information

A terminal may house an end-system conforming to the X.200 Open Systems Interconnection (OSI) reference model ("OSI endsystem"). The concatenated PTN addressing information will then include the OSI network layer address and thus provide the capability to identify the OSI network layer service access point (NSAP).

The syntaxes and semantics of OSI NSAP addresses are defined in IS 8348/ADD 2. In addition, the syntaxes and semantics of the domain specific part (DSP) are defined in Standard ECMA-117 or in MAP, respectively.

OSI NSAPs can be addressed in one of the three following ways, see figure 40:

- i) The OSI NSAP address consists of the IDP only. There is no subaddress, and the OSI endsystem infers the complete NSAP address from the PTN number, i.e. from the NPI, the TON and the number digits. There is no Domain Specific Part (DSP).
- ii) The OSI NSAP address comprises an AFI and an IDI. The PTN number, i.e. the NPI, TON and number digits, is repeated in the subaddress. A DSP may or may not be present.
- iii) The OSI NSAP address, conveyed as the subaddress, comprises AFI and IDI which are not related to the PTN number but, eg., to another private or public network number. A DSP may or may not be present.

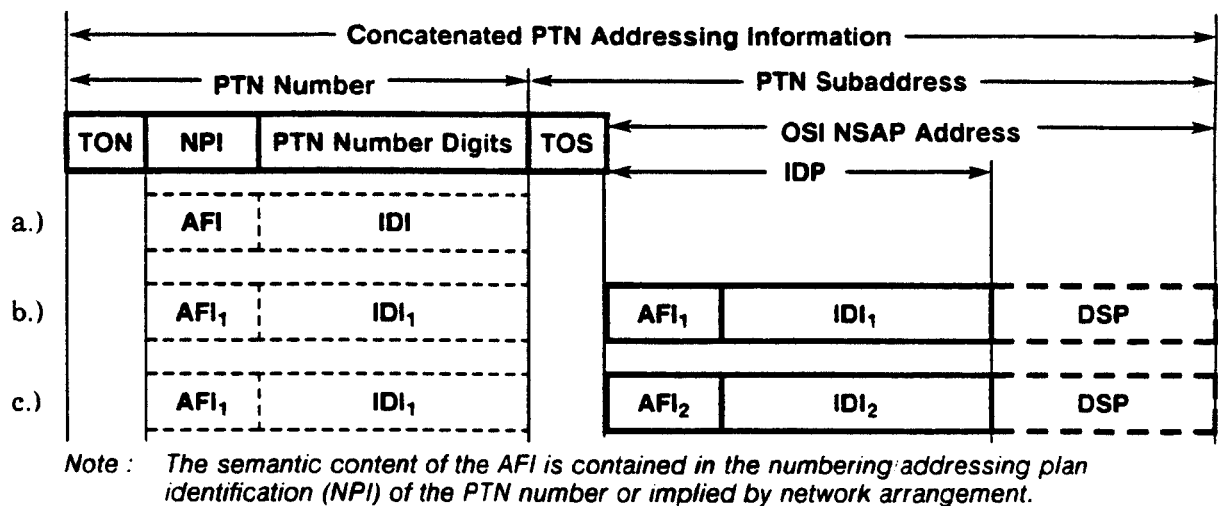

Figure 40 - Embedment of OSI Network Layer Addresses in Concatenated PTN Addressing Information

15.2 Embedment of Other Information in the Subaddress

Information other than OSI NSAP addresses can be interchanged as a subaddress between TEs. Possible applications are:

- non-OSI domain specific addresses;
- personal identification or password information.

15.3 Conveyance of Subaddresses through a PTN

A subaddress can contain information which is not available from the corresponding number. For example:

- case ii) in 15.1, if a DSP is included;
- case iii) in 15.1;
- other information as described in 15.2.

Therefore the conveyance of the subaddress across the PTN is fundamental, and should be supported as part of signalling protocols for the basic call. Furthermore, the presentation of subaddresses to TEs should not be subject to the various restrictions which may apply to the presentation of numbers.

Note 25:

If a user wishes to restrict the presentation of his subaddress to other users, he can arrange that his TE does not submit the subaddress to the network.

Section 5 - Routing

This Section 5 is concerned with the subject of routing at the Network Layer in PTNs, primarily with routing for connection oriented services. It examines strategies for routing within a PTN and for interworking situations, e.g. with public ISDNs and other public networks. Further information on routing in general can be found in ECMA TR/50 and ISO/IEC TR 9575.

16 General

Routing at the Network Layer is the process of selecting a sequence of connection elements which are able to provide a continuous communication path with a defined capability between users which require to communicate. For routing within a PTN, connection elements include the following:

- exchanges of the PTN,
- inter-PTNX connections,
- PTN accesses,
- TEs attached to PTN accesses,
- accesses to other networks,
- other resources within a PTN, e.g. conference bridges, interworking units.

A call, or instance of a service, within a PTN is established by providing a communication path between the two PTN users involved. It is the routing function which selects the path. One of the PTN users (the calling user, or source of the call) is used as a starting point for the routing process. The routing process also requires the address of the other user (the called user, or destination of the call), which it uses to determine the location of the called user and potential paths through the PTN to that location. The path chosen must satisfy the requirements of the service requested and must meet the requested bearer capability.

Where the source of a call is outside the PTN, the PTN receives a call request from another network. The point of access from that other network can be regarded as the source of the call, as far as PTN routing is concerned.

Where the destination is outside the PTN, the PTN is responsible for selecting the next network, whose responsibility it will be to continue routing towards the destination. The PTN is also responsible for selecting the point of access from the PTN to the next network, and a path through the PTN to that point of access. Optionally the PTN may also select networks beyond the next network, e.g. public transit networks, and indicate those networks to the next network.

Sometimes the destination may be within the PTN, but because there is no path available through the PTN to that destination it becomes necessary to choose a path through another network. The considerations above for destinations outside the PTN also apply in this situation.

To reach a given destination from a given source, there is frequently a choice of possible paths, and the routing process is required to choose a path with spare capacity, i.e. the necessary resources need to be

available. Where there is more than one suitable path with spare capacity, the choice is normally required to be based on cost, either direct (e.g. call charges by other networks) or indirect (e.g. leasing charges).

Where the routing process is unable to find a suitable path with spare capacity, the call has to be rejected. The possibility of negotiating service parameters or queuing for resources is for further study.

17 Routing requirements

This Clause lists the requirements which should be met by a routing mechanism in a PTN.

17.1 Functional Requirements

- i) The routing process has to determine, from the destination address (e.g. the PTN number) the location of the destination, i.e. whether it is within the PTN or in another network.
- ii) If the destination is within the PTN, the routing process has to determine the PTNX to which the destination is attached, and then determine a path through the PTN to that PTNX. Factors influencing the selection of a path through the PTN are listed in 18.1.1.
- iii) If the destination is outside the PTN, the routing process has to determine the next network to route to, the PTNX from which to access the next network, and also the choice of the first exchange of the next network if more than one exchange is accessible from the gateway PTNX. Factors influencing these are listed in 18.1.2. The routing process also has to select a path through the PTN to the gateway PTNX. Factors influencing this are listed in 17.1.1. Routing to a destination outside the PTN is therefore influenced by the combination of the factors in 18.1.2 and the factors in 18.1.1.
- iv) If the destination is outside the PTN, the routing process may also optionally select networks beyond the next network and indicate these to the next network. Factors influencing the selection of networks beyond the next network are listed in 17.1.3.
- v) If the destination is within the PTN but not reachable by paths within the PTN, it may be possible to route to the destination via (an)other network(s). The requirements above for routing to a destination outside the PTN apply.
- vi) Mobility should be catered for, by allowing a PTN user (identified by a PTN number) to move between different PTNXs in a PTN. The degree with which this is dynamic can vary. e.g.:
 - moves can only be made by manual instruction to network management;
 - moves can be indicated by inserting a smart card into a terminal at the new location;
 - roaming cordless terminals.
- vii) Certain supplementary services may affect the destination. In particular, automatic call distribution involves the distribution of calls between different destinations, depending on the ability of each destination to accept calls.

17.1.1 Factors Influencing Routing through a PTN

Routing through a PTN to the destination PTNX or gateway PTNX will depend on the following.

- i) The ability of a path to support the required basic service and any other user-specified requirements, e.g. special QOS, special routing (e.g. for maintenance).
- ii) The cost of a path, in terms of the cost of the resources used. This is normally indirect, e.g. based on leasing costs for resources used. Typically it depends on the number of hops and the distance of each hop, but it could also have an adjustment according to (long term) scarcity of resources (e.g. if a path between two PTNXs is known to be under-equipped) or according to quality (e.g. to discourage use of higher quality paths than needed).

- iii) Resources (e.g. PTNXs, inter-PTNX connections) which are out of service or scheduled to be taken out of service within the expected duration of the call.
- iv) Resources which are congested at the time of routeing.
- v) Possibly resources which are approaching congestion at the time of routeing.
- vi) The positioning and availability of resources for the support of supplementary services, e.g. conference bridges.

17.1.2 Factors Influencing Routeing to Another Network

The choice of the next network to route to when the destination is outside the PTN or not currently reachable by paths within the PTN, the choice of the gateway PTNX, and also the choice of the first exchange of the next network if more than one exchange is accessible from the gateway PTNX are dependent on the following.

- i) The ability of a network to reach the destination.
- ii) The ability of another network and an access to that network to support the required basic service and any other user-specified requirements, e.g. special QOS, transit network selection. This may be known in advance by the PTN or may have to be determined by trial and error.
- iii) The cost of using the other network, which will depend on the service, the distance through the other network (e.g. local, national, international, which in turn are affected by the point of access) and the time of day. It may also be possible to take into account any anticipated tariff changes during the expected duration of a call. This information should be known in advance by the PTN.
- iv) Accesses out of service or congested. This is known by the PTN (although not necessarily by all PTNXs).
- v) The ability of the other network to route the call (i.e. depending on static ability to reach the required destination, and whether there is congestion or equipment out of service). This information is not necessarily available in advance to the PTN, and therefore may have to be determined by trial and error.

17.1.3 Factors Influencing the Selection of Networks beyond the Next Network

The selection of a network or networks beyond the next network, e.g. public transit networks, depends on the following.

- i) The ability of a network to reach the destination.
- ii) User requirements for routeing via a specific network.
- iii) The ability of a network to support the required basic service and any other user-specified requirements, e.g. special QOS. This may be known in advance by the PTN or may have to be determined by trial and error.
- iv) The cost of using a network, which will depend on the service, the distance through the network (e.g. local, national, international, which in turn may be affected by the point of exit from the PTN), and the time of day. It may also be possible to take into account any anticipated tariff changes during the life of a call. This information should be known in advance by the PTN.
- v) The ability of a network to route the call (i.e. depending on whether there is congestion or equipment out of service). This information is not necessarily available in advance to the PTN, and therefore may have to be determined by trial and error.

17.1.4 Other Factors Influencing Route Selection

- i) Although the user should not normally need to supply any routing information to the network when requesting call establishment, it should be permissible in circumstances such as the following:
 - the need to route through a particular network where the user has an account, in order for that user to be charged, rather than the PTN (which may not have an account);
 - where the user has special knowledge of costs, malfunctions, quality of service, etc.;
 - for maintenance purposes, in order to check out a particular route.
- ii) PTN user service profiles may impose restrictions on routing, in particular as far as access to other networks are concerned. The reasons for such restrictions include:
 - to deny unauthorized access (normally where charging is involved);
 - to reserve limited resources for those with the most need.
- iii) There may be regulatory restrictions on routing, e.g. on routing a call from a public network on to the same or another public network.

17.2 Performance Requirements

In addition to the functional requirements listed above, the routing mechanism should take account of and strike a suitable balance between the following performance requirements:

- i) The routing mechanism should not use excessive resources of the communications network.
- ii) The routing mechanism should enable an adequate response to changes in the network, including configuration changes (e.g. installation of a new PTNX, inter-PTNX connection or access to another network) and equipment states (e.g. faulty, maintenance states, congested).
- iii) The user should be given an adequate quality of service from the point of view of the time taken to establish a call or to notify the user of failure to route a call.

18 Routing mechanisms

18.1 Routing Information Base

For any call incoming to an PTNX, the PTNX must determine from the address of the called user whether it is a PTN user on that PTNX. If it is not, the PTNX must, as a minimum, determine the route to be taken out of that PTNX, taking into account the location of the destination and the PTNXs knowledge of the PTN and of any other networks which might be involved in reaching the destination. This knowledge is assumed to be held in a Routing Information Base (RIB). The RIB might be physically in the PTNX or elsewhere, e.g. centralized. However, the separation of the RIB from the PTNX may have impact on quality of service.

Keeping the RIB up-to-date is the responsibility of Network Management. This can be dynamic to varying degrees, e.g.:

- the RIB is virtually static, being changed only when new equipment is installed;
- the RIB is dynamic to the extent of taking account of resources temporarily out of service;
- the RIB is dynamic to the extent of having knowledge of resources in use.

Also there are different degrees to which the RIB can automatically adapt to changes, as opposed to relying on human input.

Possible mechanisms for maintaining the RIB will be considered as part of ECMA studies on Management of PTNs.

18.2 Source and Destination Routeing

As a minimum, the routeing function of an PTNX must determine the path, i.e. circuit and, if applicable, channel, out of that PTNX towards the next PTNX or network. This is done on the basis of the destination address, using the RIB to identify possible paths out of the PTNX towards that destination, and choosing the optimum (e.g. cheapest) path with available capacity. The next PTNX must then perform a similar operation, again based on the destination address. This means of routeing can be called "destination routeing", since at each node routeing is aimed at getting to the destination.

Alternatively, an PTNX may have sufficient information in its RIB to enable it to determine the entire path to the destination or to the point of access to the next network, and optionally the identification of networks beyond the next network. Where an PTNX determines the entire path, information needs to be passed forward to subsequent PTNXs to inform them of the selected path. Onward routeing by subsequent PTNXs is then constrained to using this path. Similarly, any information regarding networks beyond the next network needs to be passed to the next network, and subsequent routeing is constrained to using those networks. This method of routeing can be called "source routeing", since the entire path is determined at the source.

Source routeing might typically be done at an originating PTNX. Alternatively, it could be done at an originating TE, e.g. where the user specifies the sequence of routes, perhaps for maintenance purposes.

Source routeing and destination routeing each have advantages and disadvantages over the other.

18.2.1 Advantages of Source Routeing Compared with Destination Routeing

- i) Route determination only has to be done once, thus minimising computation overheads in the PTN.
- ii) Avoids the possibility of looping, which could occur with destination routeing under certain conditions, particularly if the routeing algorithm is not chosen carefully.
- iii) Avoids the possibility of a transit PTNX choosing an alternative route which is not the cheapest route available from the source to the destination, but happens to be the cheapest from that transit PTNX to the destination.
- iv) Avoids independent attempts by several PTNXs at trying to route through a distant PTNX, inter-PTNX connection or access to another network which is not currently available.
- v) Only the PTNX doing the source routeing (normally the originating PTNX) needs to have knowledge of the calling user's service profile in order to ensure that the calling user is authorized to use potential routes. With destination routeing the service profile (or relevant parts) has to be passed forward and has to be meaningful to each PTNX.

18.2.2 Advantages of Destination Routeing Compared with Source Routeing

- i) Avoids the need for PTNXs to have a complete knowledge of the network topology and states other than immediate inter-PTNX connections and accesses to other networks. With source routeing an PTNX has to have a complete knowledge of the network topology and the states of all PTNXs, inter-PTNX connections and accesses to other networks. Ideally this knowledge should include the state of occupancy of such resources so that congestion can be avoided, which implies that the RIB has to be highly dynamic.
- ii) Each PTNX can select from a number of possible ongoing routes, without being constrained by the sequence of routes determined by source routeing. This means that a call is less likely to have to be cleared back to the PTNX which carried out the source routeing, in order to select an alternative sequence of routes. This will have a beneficial effect on call establishment times.

The chances of having to clear back a call to the PTNX which carried out source routing can be significantly reduced by ensuring that that PTNX has sufficient information on the occupancy of resources. But this information can never be 100% up-to-date and the provision of such information incurs large overheads.

18.2.3 Hybrid Methods

A combination of source and destination routing can be employed, whereby an PTNX imposes some constraints on routing by subsequent PTNXs and/or networks but does not specify the exact path. For example, an PTNX may determine that a call is to be routed to a particular network and that access to that other network is to be from a particular gateway PTNX, but without constraining the path through the PTN to that gateway PTNX. As another example, the originating TE or PTNX may specify a particular public transit network to be used, but without specifying the path to that transit network.

In other words, routing can be viewed as being performed in stages, where each stage uses destination routing to get to the destination for the stage. The destination for a stage is in fact an entity determined by source routing for that stage.

A hybrid method could also include the possibility of specifying at source an entity (e.g. inter-PTNX connection, PTNX, network) to be avoided (because of known problems).

The requirement that PTNs should cater for the mobility of PTN users and therefore the mobility of PTN numbers leads to the need to translate a PTN number into a physical address of a port on the PTN where that user is to be found. Mechanisms for doing this are for further study. Whatever mechanism is used, the translation will probably be performed only once (at source) and with subsequent routing on the basis of the physical address so obtained.

Hybrid methods can be used to capitalize on the advantages of the two methods. The most appropriate balance between source and destination routing for a given PTN will depend on factors such as:

- the topology of the PTN;
- the locations of accesses to adjacent networks;
- the ability to access networks beyond adjacent networks;
- charges incurred in using other networks;
- the requirements of the PTN administration;
- the methods available for maintaining the RIB, etc..

A typical solution might be the use of source routing to identify points of access to adjacent networks and networks beyond adjacent networks, but destination routing for selecting a path through the PTN (except where routes through the PTN are specified by the originating TE, e.g. for maintenance purposes). Translation between PTN numbers and physical addresses should also be done only at source.

18.2.4 Impact on Signalling for Call Control

Source routing requires the passing forward of additional signalling information at call establishment time in order to constrain routing at subsequent PTNXs. This capability is therefore also required for hybrid routing. Even if a PTN were to normally operate on a fully destination basis, there would still be a need to pass forward routing information originating at the TE. Signalling protocols shall therefore be capable of passing forward routing information, including the following:

- identification of the next network to route to;

- identification of the gateway PTNX from which to access the next network;
- identification of the local exchange of the next network, if more than one local exchange can be accessed from the gateway PTNX;
- identification and authorisation codes for networks beyond the next network;
- identification of transit PTNXs;
- identification of particular inter-PTNX connections or accesses to other networks, and possibly particular channels on such connections and accesses.
- physical address of the called user, as distinct from its PTN number.
- identification of entities to be avoided.

A PTNX receiving such information should route via or towards (or avoid) the entities specified and pass such information on to the next PTNX or network if still of relevance.

18.3 Subjects for Standardization

An ECMA Standard on routing in PTNs should be based on the following considerations:

- destination routing should be a minimum which a PTN and its PTNXs support;
- source or hybrid routing should be options which have to be tolerated by those parts of the PTN which by themselves do not employ source or hybrid routing;
- any routing other than destination routing should be treated as an additional network feature, see 19.7;
- routing functional entities, the types of information to be interchanged between them and the signalling protocols needed to convey them should neither prevent nor hinder any enhanced routing strategy.

A possible ECMA Standard on routing in PTNs should also identify requirements to be fulfilled by public ISDNs.

Documents which should be taken into consideration are: ECMA TR/50, ISO 9542, and ISO 10589.

Section 6 - Services

This Section 6 specifies general concepts for the description and definition of the basic and supplementary services applicable to PTNs. The impact on both the public ISDN and the PTN is defined and solutions are proposed which will enable harmonization between PTNs and public ISDNs.

19 General Service Considerations

19.1 Classification of Services

The services offered to a PTN user comprise basic and supplementary services.

Basic services are divided into basic bearer services and basic teleservices.

Supplementary services can apply to both basic bearer services and basic teleservices.

The classification of services is the same as for an ISDN, see CCITT Rec. I.210.

These terms, when applied to public ISDNs, emphasize possible marketing relevance to a public ISDN provider, i.e. subscription and charging on a per service basis. For consistency, these terms are used

also for PTNs, even though a PTN provider might make some services generally available (without the need for "subscription") and might not charge on a per service basis.

19.2 Control of Basic Services

A basic call is an instance of the use of a basic service, see Standard ECMA-142.

Functionality for the control of a basic call is required in the calling PTN user's TE, in the called PTN user's TE, and in each of the PTNXs through which the call is routed, i.e. the Originating PTNX, the Terminating PTNX and any Transit PTNXs. Signalling protocols within the Control Plane of the Protocol Reference Model enable functions in different physical equipments to communicate in order to cooperate in the control of basic calls. A signalling connection is established between the various equipments involved for the duration of the basic call.

Signalling protocols are required at the Q reference point and at the S reference point .

19.3 Control of Supplementary Services

Functionality for the control of a supplementary service will exist in various places, e.g.:

- the TE of the served user;
- the TEs of other users affected by the service;
- the served user's PTNX;
- the PTNXs of other users affected by the service;
- PTNXs with special capabilities, e.g. conference bridging.

Signalling protocols within the Control Plane of the Protocol Reference Model enable supplementary service functions in different physical equipments to communicate in order to cooperate in the control of supplementary services. Signalling information has to be passed transparently through intervening equipment (e.g. Transit PTNXs) not involved in the supplementary service.

Where signalling is required between supplementary service functions which are located at physical equipments involved in the basic call to which the supplementary service applies, the signalling connection which exists for basic call control can also be used to support supplementary service signalling. At other times supplementary service signalling will be independent of any basic call signalling, e.g.:

- where the supplementary service signalling is outside the context of a basic call (e.g. for activation or deactivation of a supplementary service);
- where the supplementary service signalling occurs prior to establishment or after clear-down of the signalling connection for the basic call to which it applies;
- where the supplementary service signalling involves physical equipments which are not involved in the basic call (e.g. equipment containing databases).

Signalling protocols for use in conjunction with a basic call signalling connection and for use independently of any basic call signalling connection are required at the Q and S reference points.

Note 26:

Supplementary services which have not been standardised can still be supported in a PTN. Signalling protocols will provide escape mechanisms for manufacturer specific information for the support of supplementary services which are not standardised, or for the support of non-standard extensions to standardised supplementary services.

19.4 Specification Method for ECMA Standards on Services

The three stage method specified in ENV41005 is applicable to ECMA Standards for basic and supplementary services.

For a given service or set of related services, the following ECMA Standards will be produced:

- a Standard containing the stage 1 and stage 2 specifications;
- a Standard containing the stage 3 specification for the protocol at the Q reference point, if applicable;
- a Standard containing the stage 3 specification for the protocol at the S reference point.

Whilst stage 3 specifications are concerned with physical interfaces, stage 1 and stage 2 specifications provide a conceptual view of the service. The models to be used for stage 1 and stage 2 specifications are described below.

19.4.1 Service Model for Stage 1 Specifications

The Network Layer provides the bearer capabilities necessary for the support of bearer services, teleservices, i.e. for the support of calls. It also provides support for supplementary services. A user accesses the Network Layer service through Network Service Access Points (NSAP). An NSAP is identifiable by an address, which in a PTN is generally in the form of a PTN number or the concatenation of a PTN number and a subaddress (see Section 4).

The Network Layer incorporates functions for the control of calls and supplementary services and functions for the transfer of user information. Control functions are viewed as being provided by a Network Call Control entity, which provides, through service access points (SAPs), a service for the control of calls and supplementary services. Within a user's equipment, coordination functions make use of the services of the Network Call Control entity and coordinate call control with the transfer of user information, thereby providing a complete Network Layer service to users. See figure 41.

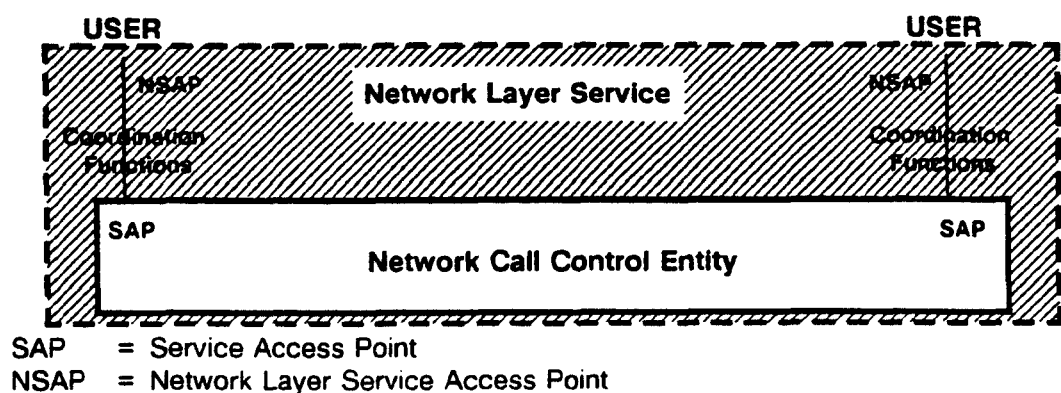

Figure 41 - Service Model

The Network Call Control SAPs are indirectly accessible via NSAPs. Primitives used across Network Call Control SAPs are mappable to primitives at an NSAP. However, NSAP primitives relating to the transfer of user information do not have equivalents at a Network Call Control SAP. An address which identifies an NSAP also identifies a Network Call Control SAP by implication.

In a Stage 1 specification, the control aspects of services are specified in terms of the primitives at Network Call Control SAPs. The entire Network Call Control is treated as a single entity.

19.4.2 Service Model for Stage 2 Specifications

In Stage 2 specifications, the internal behaviour of Network Call Control is specified by breaking it down into a number of Functional Entities (FE) and specifying the information flows between them. The result is a model of the form shown in figure 42. Particular basic and supplementary services will use particular models based on this generic model.

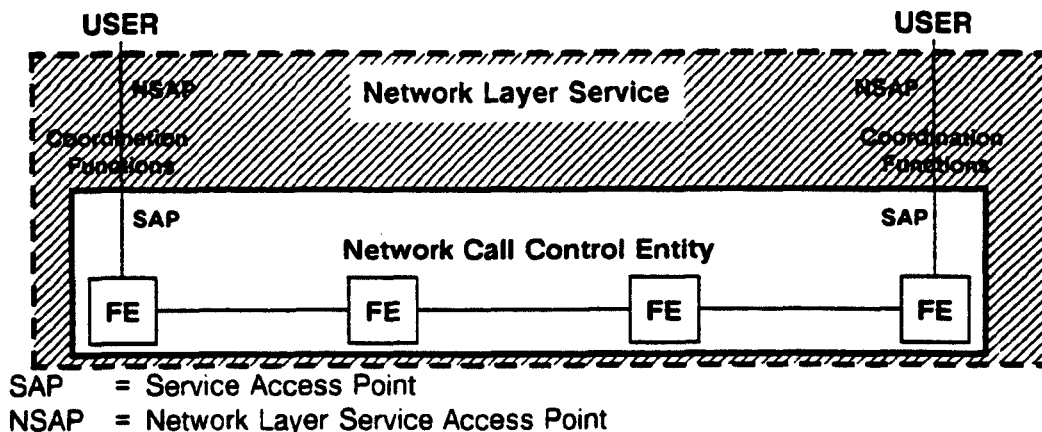

Figure 42 - Generic Model for Stage 2

19.5 Relationship to Services Provided in Public ISDNs

Basic services specified for PTNs will in general be the same as those specified for public ISDNs.

For many of the supplementary services specified for PTNs there will be corresponding services specified for public ISDNs. There will be other supplementary services specified for PTNs which will not be specified for public ISDNs, and vice versa.

Where the same service is to be specified for PTNs and public ISDNs, the service specification (stage 1) should be common, as far as possible, so that users can have similar expectations. This does not prevent the specification of enhancements to services only for PTNs or only for public ISDNs.

The concept of terminal interchangeability, not only between different PTN accesses and between different public ISDN accesses, but also between PTN and public ISDN accesses, is important, see figure 43.

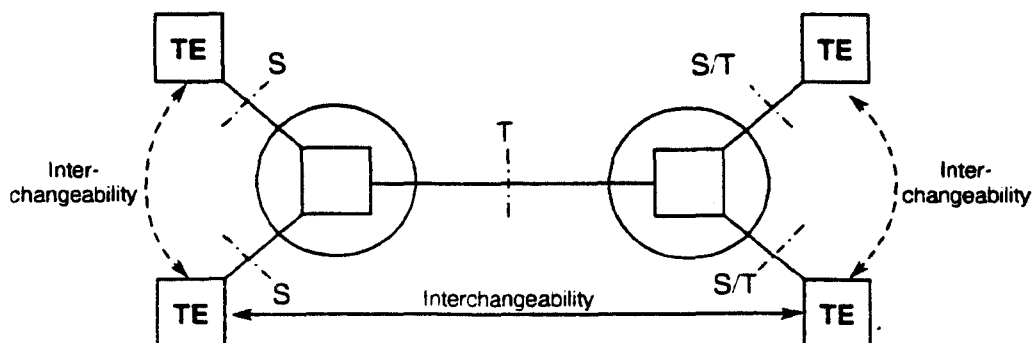

Figure 43 - Terminal Interchangeability

The need for terminal interchangeability between PTNs and public ISDNs means that signalling protocols at the S reference point should be compatible with public network signalling protocols at the coincident S/T reference point. This applies to any basic or supplementary service which is common to PTNs and public ISDNs. This does not preclude protocol extensions being specified for the support of

additional services or extensions to services applicable only to PTNs or only to public ISDNs. However, this should be done in a manner which allows clean recovery from any attempt by a TE to use a protocol extension which is not supported by the network to which the TE is attached, or by a network to use a protocol extension which is not supported by the TE.

This also means that those aspects of stage 2 specifications which impact upon the signalling protocol at the S reference point should be compatible with the corresponding parts of the stage 2 specifications for public ISDNs.

With the above points in mind, the production by ECMA of "delta" Standards specifying only differences compared with corresponding standards for the public ISDN, where they already exist, might be a possibility. This avoids the unnecessary duplication of large amounts of text and diagrams, and also minimises the possibility of inadvertently producing differences between standards for the private and public ISDN. "Delta" standards can be used for stages 1 and 2 and for stage 3 at the S reference point, but not at the Q reference point.

In some cases it may not be necessary to produce a separate Standard for PTNs.

19.6 Service Interworking between PTNs and Public ISDNs

Each service requires that a served user can access a service provider. Service interworking between networks involves service providers in different networks.

Note 27:

The term "service provider" is to indicate, in a generic way, all technical means outside the TE which are required to fulfil a particular service. The term does not address any regulatory or legal issues.

When calls pass through a PTN and a public ISDN, the service providers of both networks cooperate in the provision of basic and supplementary services. For basic services, both service providers have a certain level of involvement, but there may be some aspects of a service which are catered for by only one of the service providers, e.g. echo cancellation for certain basic services.

For supplementary services the degree of involvement of each service provider can vary considerably according to service and circumstances. To give an indication of how the involvement is shared for particular supplementary services, the following categories have been identified.

- Local

The service provider in only one of the networks (the served user's network) is involved (see figure 44). Some supplementary services in this category involve the sending of notifications to remote parties attached to the other network. Therefore the only involvement of the service provider in the other network is in the transparent conveyance of these notifications.

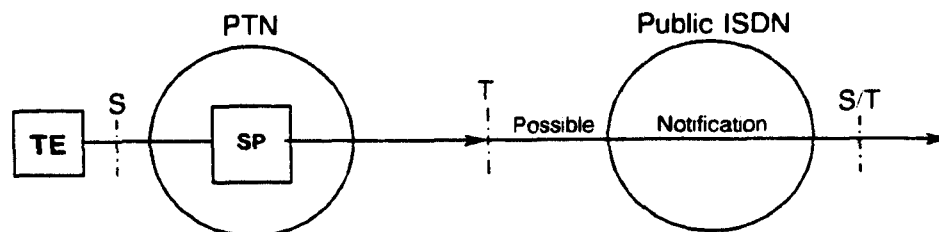

SP = Service Provider

Figure 44 - Example of Local Provision of a Supplementary Service by a PTN

In some cases a PTN can act as the user of a supplementary service provided by a public ISDN, see figure 45.

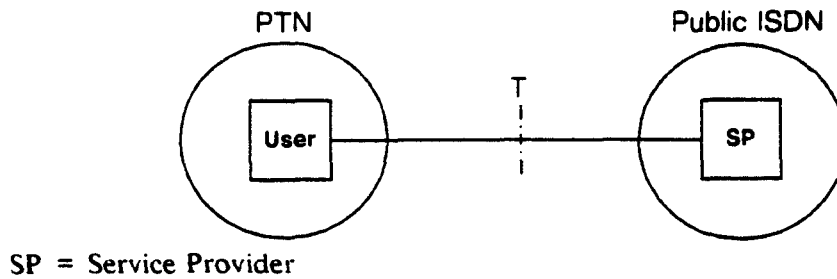

Figure 45 - Example of a PTN as User of a Service Locally Provided by the Public ISDN

- Double

This is a special case of "local", whereby a PTN uses a service provided locally by a public ISDN while simultaneously providing a similar service locally to PTN users, see figure 46.

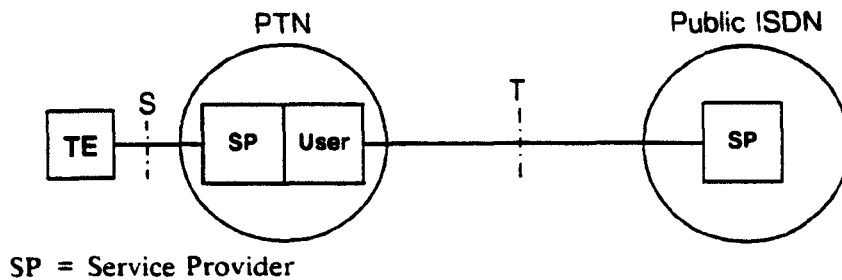

Figure 46 - Example of Dual Provision of a Supplementary Service

- Cooperative

The service providers of both networks are involved. This requires intercommunication between both networks' service providers, whose functions complement each other, see figure 47.

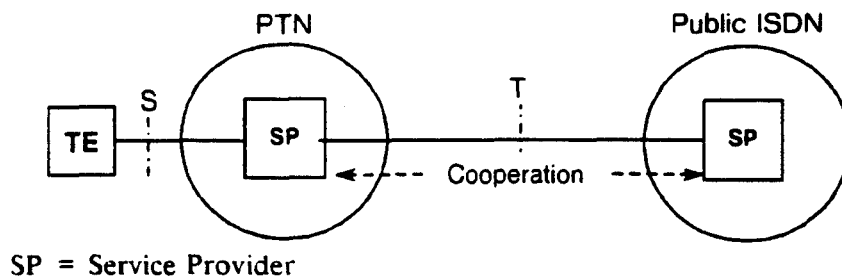

Figure 47 - Example of Cooperative Provision of a Supplementary Service

Some services can fall into different categories, depending on the actual routing of a call.

The above considerations are to be taken into account by the signalling protocol at the T reference point. Basically signalling at the T reference point has to cater for the following:

- i) cooperation between service providers in the provision of basic services;
- ii) use by the PTN of supplementary services provided locally by the public ISDN;

- iii) sending of notifications to the PTN resulting from supplementary services provided locally in the public ISDN;
- iv) sending of notifications to the public ISDN resulting from supplementary services provided locally in the PTN;
- v) cooperation between service providers in the provision of cooperative supplementary services.

Items ii) and iii) can be satisfied by a signalling protocol similar to that at the coincident S/T reference point. Items i), iv) and v) mean that there are special signalling requirements at the T reference point, compared with the coincident S/T reference point.

19.7 Additional Network Features

PTNs can offer various features which can improve the handling of certain calls or the performance of the network as a whole, rather than directly benefitting a particular served user. However, indirect benefits may be perceived by users, e.g. the avoidance of calls with inadequate quality of service or the minimising of charges incurred. As there is no served user, these features are not called supplementary services. Instead they are given the name Additional Network Features (ANF).

Certain ANFs are appropriate for standardisation. These will be specified using a three stage method similar to the method used for supplementary services. However, the "user" of an ANF is not an ordinary PTN user but an entity within the PTN.

Note 28:

ANFs which have not been standardised can still be supported in a PTN. Signalling protocols will provide escape mechanisms for manufacturer specific information for the support of ANFs which are not standardised, or for the support of non-standard extensions to standardised ANFs.

In general, ANFs have impact on the signalling protocols only at the Q reference point. At the present time there are no prospects of interworking with equivalent features in public ISDNs.

Blank page

Annex A
Off-Premises PTN Users

Figure A1 shows remote users of an ISPBX type PTNX which are located outside the ISPBX premises.

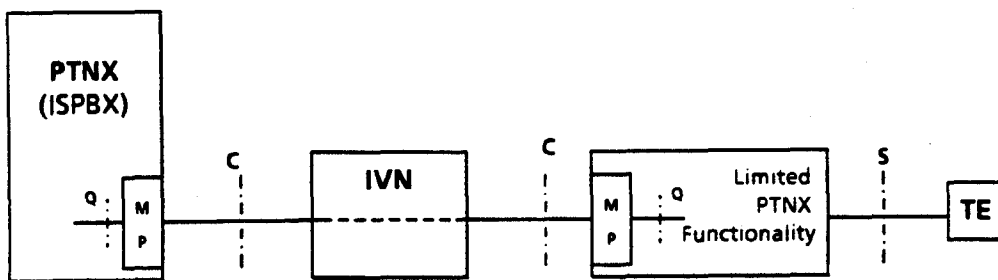

Figure A.1 - Off-Premises Extensions

Any of the scenarios described in Section 3 for inter-PTNX connections can, in principle, be used to connect a remote user's TE to the ISPBX.

The TE needs to be adapted to the IVN. As a minimum this involves relevant MP functions on the PTN user's premises.

Blank page

Annex B

PTNX Connections to Public ISDNs

This annex deals with the connection of PTNXs to public ISDNs. The description of this connection serves as a basis for the understanding of PTNXs within the overlay concept as well as of problems which may arise when public ISDNs have to interwork with PTNXs within the concatenation concept.

B.1 Access Types and Physical Interfaces

The access types underlying this interworking function and used at the T reference point can be

- one or a multiple of basic accesses, or
- one or a multiple of primary rate accesses, or
- any combination of basic and primary rate accesses.

The physical interfaces used are the S0 and the S2 interfaces, as described in ETS 300 011 and ETS 300 012.

Note

For primary rate accesses, the S2 interface is predominant in Europe and some other regions of the world outside North America. In the latter, the S1 interface is used instead.

B.2 Protocol Reference Model

Based on the ISDN protocol reference model (CCITT Rec. 1.320), the connection of a PTNX to the Public ISDN is shown in figure B-1.

The following protocol planes across the public ISDN can be identified:

- the Network Control plane (NC) conveys information for the control (e.g. establishment and dis-establishment) of connections.
- the Network User plane (NU) conveys information between the two PTNXs.

TC, TU, PC and PU are as defined in clause 8.

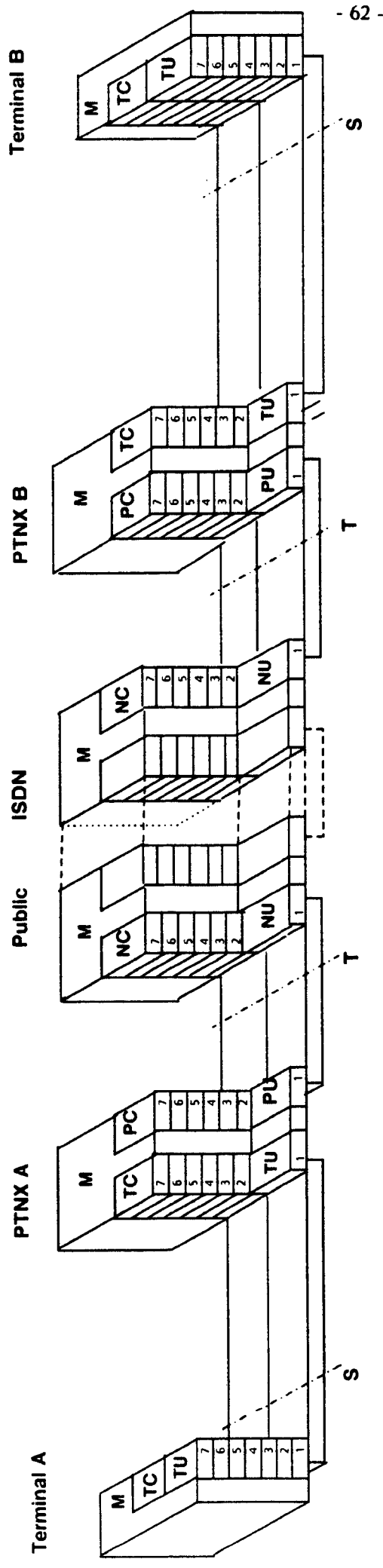

Legend: M Management Entity
S, T S, T reference points

- Notes:
- 1 As an example this Figure shows a circuit mode bearer service supporting the TU, PU and NU planes.
 - 2 Also as an example, the control planes TC, PC and NC are modelled into 7 layers. Whether for all functions a full 7 layer model is required is for further study.
 - 3 For simplicity, the coordination functions between the user plane and the control plane, and the plane mapping functions in the PTNXs, have been omitted.

Figure B.1 - PTNX-to-ISDN Protocol Reference Model

Annex C

Interworking for Identification Numbers between Public ISDN and PTN

It is assumed that:

- all PTN users reachable from the public ISDN can be reached via the DDI supplementary service;
- identification numbers according to the ISDN numbering plan are interchanged between the PTN and the public ISDN numbering domains in both directions;
- either network will obey any presentation restrictions, i.e. it will indicate restriction to the foreign domain without revealing the number itself.

In figure C-1 public ISDNs A and B are assumed to be different local exchanges of the same or of different public ISDNs. Normally, call requests from PTN user A to user B are routed via PTNX A and public ISDN A. In rerouting situations (e.g. due to failure, congestion) the call may be established via PTNX B and public ISDN B, as shown by the dotted line.

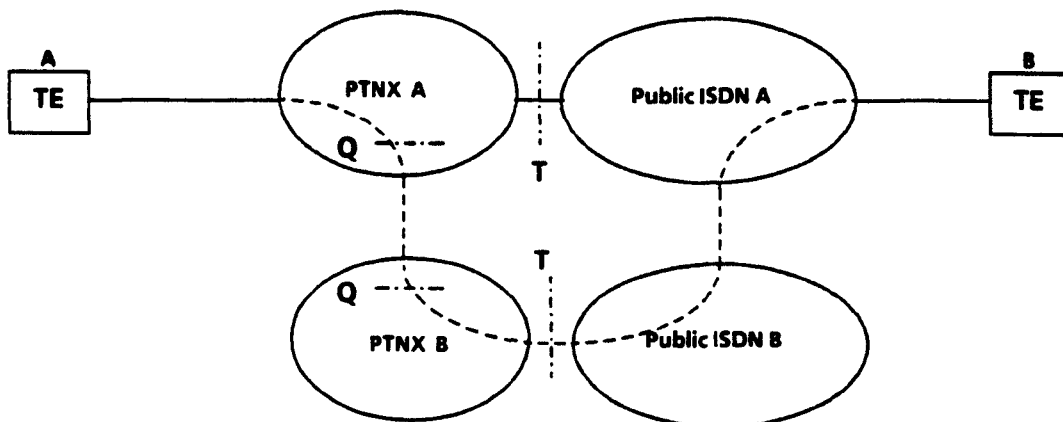

Figure C.1 - Example of Interworking between PTN and Public ISDN

PTNX B should not include user A's DDI number, according to the DDI arrangement between PTNX A and public ISDN A, when establishing the call to public ISDN B. This is because public ISDN B will understand only DDI numbers in accordance with the DDI arrangement between PTNX B and public ISDN B. Instead, PTNX B should supply public ISDN B with an identification number which is significant to public ISDN B. An international ISDN number will also be significant, but a national number will suffice when public ISDN A and public ISDN B are in the same country.

Public ISDN B should accept this identification number even though it is outside the context of any DDI arrangement with PTNX B and therefore cannot be verified. Public ISDN B should mark a number as "user provided, not screened".

Blank page

Annex D
Abbreviations and Acronyms

ADD	Addendum
AFI	Authority and Format Identifier
AHLF	Additional High Layer Function
ALLF	Additional Low Layer Function
BHLF	Basic High Layer Function
BLLF	Basic Low Layer Function
C	C Reference Point
CC	Call Control
CCA	Call Control Agent
CE	Connecton Element
CH	Call Handling (functional grouping)
CRF	Call Related Function
DCC	Data Country Code
DSP	Domain Specific Part
DDI	Direct Dialling-In (supplementary service)
EPRM	Extended Protocol Reference Model
FE	Functional Entity
FH	Frame Handler
ICD	International Code Designation
IDI	Initial Domain Identifier
IDP	Initial Domain Part
IH	Intervening Network Handler (functional entity)
ISCTX	Integrated Services Centrex
ISDN	Integrated Services Digital Network
ISPBX	Integrated Services Private Automatic Branch Exchange
IVN	Intervening Network
IWU	InterWorking Unit
LAN	Local Area Network
MAC	Medium Access Control
MAP	Medium Access Protocol
MSN	Multiple Subscriber Number (supplementary service)
MP	Mapping (functional grouping)

NC	Network Control plane, i.e. either IVN or Public ISDN control plane
NSAP	Network Service Access Point
NP	Numbering Plan
NPI	Numbering Plan Identifier
NU	Network User plane, i.e. either IVN or Public ISDN user plane
OSI	Open System Interconnection
Q	Q Reference Point
PC	PTN Control plane
PH	Packet Handler
PNP	Private Numbering Plan
PSDN	Public Switched Data Network
PSTN	Public Switched Telephony Network
PTN	Private Telecommunication Network
PTNX	Private Telecommunication Network Exchange
PU	PTN User plane
NT1, NT2	Network Termination 1, Network Termination 2
RIB	Routeing Information Base
S	S Reference Point
S ₀	Interface on a Basic Access at the S Reference Point ["S / Index 0,.... Mbit/s]
S ₁	Interface on a Primary Rate Access at the S Reference Point ["S / Index 1,.... Mbit/s (23 B + D as used, e.g., in North America)]
S ₂	Interface on a Primary Rate Access at the S Reference Point ["S / Index 2,.... MBit/s (30 B + D as used, e.g., in Europe and Australia)]
SAP	Service Access Point
SAPI	Service Access Point Identifier
SNPA	SubNetwork Point of Attachment
SRF	Switching and Relaying Function
SW	Switching functional grouping
T	T Reference Point
TE	Terminal Equipment
TC	TE Control plane
TON	Type of Number
TOP	Technical and Office Protocol
TU	TE User plane
TOS	Type of Subaddress
VPN	Virtual Private Network (feature)

History

Document history		
April 1994	First Edition	