

TR 101 177 V1.1.1 (1998-05)

Technical Report

Broadband Radio Access Networks (BRAN); Requirements and architectures for broadband fixed radio access networks (HIPERACCESS)



European Telecommunications Standards Institute

Reference

DTR/BRAN-010001 (awc00ics.PDF)

Keywords

Access, broadband, network, radio

ETSI Secretariat

Postal address

F-06921 Sophia Antipolis Cedex - FRANCE

Office address

650 Route des Lucioles - Sophia Antipolis
Valbonne - FRANCE
Tel.: +33 4 92 94 42 00 Fax: +33 4 93 65 47 16
Siret N° 348 623 562 00017 - NAF 742 C
Association à but non lucratif enregistrée à la
Sous-Préfecture de Grasse (06) N° 7803/88

Internet

secretariat@etsi.fr
<http://www.etsi.fr>
<http://www.etsi.org>

Copyright Notification

No part may be reproduced except as authorized by written permission.
The copyright and the foregoing restriction extend to reproduction in all media.

Contents

| | |
|--|----|
| Intellectual Property Rights..... | 5 |
| Foreword | 5 |
| Introduction | 5 |
| 1 Scope..... | 7 |
| 2 References..... | 7 |
| 3 Definitions and abbreviations | 9 |
| 3.1 Definitions | 9 |
| 3.2 Abbreviations..... | 10 |
| 4 Overview of High Performance Radio ACCESS network (HIPERACCESS) systems | 11 |
| 4.1 The rise of new telecommunications services and providers | 12 |
| 4.2 Competing access mechanisms for the information age..... | 13 |
| 4.2.1 Wired access systems | 13 |
| 4.2.1.1 xDSL over copper pairs..... | 13 |
| 4.2.1.2 Cable modems | 13 |
| 4.2.1.3 Fibre to the building, kerb, cabinet or home..... | 14 |
| 4.2.1.4 Electricity cables to the building | 14 |
| 4.2.2 Radio access systems..... | 15 |
| 4.2.2.1 Broadband point-to-multipoint radio relay systems..... | 15 |
| 4.2.2.2 Microwave video distribution systems, DAVIC, and Digital Video Broadcasting (DVB)..... | 15 |
| 4.2.2.3 Satellite systems..... | 17 |
| 4.2.2.4 Radio packet access systems..... | 17 |
| 4.3 HIPERACCESS - market positioning..... | 17 |
| 4.4 Target network economics | 18 |
| 4.5 Working definition of HIPERACCESS | 19 |
| 4.6 Multiple access, statistical multiplexing | 20 |
| 4.7 Service support | 21 |
| 4.7.1 Service transparency and service independence..... | 21 |
| 4.7.2 Typical customer applications..... | 21 |
| 4.7.3 Bandwidth..... | 22 |
| 4.8 HIPERACCESS deployment | 22 |
| 4.8.1 General..... | 23 |
| 4.8.2 Example deployment configurations | 23 |
| 4.8.3 Interfaces at the customer premises..... | 24 |
| 4.9 Miscellaneous issues..... | 26 |
| 5 Requirements | 27 |
| 5.1 External interfaces, and network management..... | 27 |
| 5.2 HIPERACCESS transport requirements | 29 |
| 5.2.1 Transparency..... | 29 |
| 5.2.2 Service independence..... | 29 |
| 5.2.3 Throughput requirements | 29 |
| 5.2.4 Signalling | 31 |
| 5.2.5 Performance | 31 |
| 5.2.6 Radio specific security requirements..... | 32 |
| 5.3 Operational requirements..... | 32 |
| 5.3.1 User density and market penetration | 32 |
| 5.3.1.1 Residential market | 32 |
| 5.3.1.2 Business market..... | 33 |
| 5.3.2 User reference traffic models | 34 |
| 5.3.2.1 Residential users..... | 34 |
| 5.3.2.2 Business users..... | 35 |
| 5.3.3 Installation issues | 35 |
| 5.3.4 Capacity | 36 |

| | | |
|---------|---|----|
| 5.3.5 | Radio range and coverage | 36 |
| 5.3.6 | LOS deployment; Channel models | 37 |
| 5.3.7 | Maintaining QoS | 37 |
| 5.3.8 | Frequency planning and management | 37 |
| 5.3.9 | General economic requirements | 38 |
| 5.3.10 | Environmental conditions..... | 38 |
| 5.3.11 | ElectroMagnetic Compatibility (EMC) | 38 |
| 5.3.12 | Standardization requirements | 38 |
| 5.4 | Spectrum and regulatory issues..... | 38 |
| 5.4.1 | Spectrum requirements..... | 38 |
| 5.4.2 | Operation in licence exempt bands..... | 38 |
| 5.4.3 | Co-ordination | 39 |
| 6 | Architecture..... | 39 |
| 6.1 | Reference models..... | 39 |
| 6.1.1 | GRM as applied to HIPERACCESS | 39 |
| 6.1.2 | HIPERACCESS GRM | 41 |
| 6.1.3 | GPM..... | 43 |
| 6.1.3.1 | The GPM in an ATM environment..... | 44 |
| 6.1.3.2 | The GPM in an IP environment..... | 45 |
| 6.2 | Interoperation..... | 45 |
| 6.2.1 | General | 46 |
| 6.2.2 | Coexistence | 46 |
| 6.2.3 | Air interface interoperation | 46 |
| 6.2.4 | Network and user interfaces | 46 |
| | Bibliography | 47 |
| | History | 48 |

Intellectual Property Rights

IPRs essential or potentially essential to the present document may have been declared to ETSI. The information pertaining to these essential IPRs, if any, is publicly available for **ETSI members and non-members**, and can be found in ETR 314: "*Intellectual Property Rights (IPRs); Essential, or potentially Essential, IPRs notified to ETSI in respect of ETSI standards*", which is available **free of charge** from the ETSI Secretariat. Latest updates are available on the ETSI Web server (<http://www.etsi.fr/ipr> or <http://www.etsi.org/ipr>).

Pursuant to the ETSI Interim IPR Policy, no investigation, including IPR searches, has been carried out by ETSI. No guarantee can be given as to the existence of other IPRs not referenced in ETR 314 (or the updates on the ETSI Web server) which are, or may be, or may become, essential to the present document.

Foreword

This Technical Report (TR) has been produced by ETSI Project Broadband Radio Access Networks (BRAN).

Technical Reports are informative documents resulting from ETSI studies which are not appropriate for Technical Specification (TS), ETSI Standard (ES) or European Norm (EN) status.

A TR may be used to publish material which is either of an informative nature, relating to the use or application of technical specifications, ETSI standards or european norms, or which is immature and not yet suitable for formal adoption as a standard.

The present document describes the technologies and techniques that are considered applicable to development of normative specifications for BRAN.

Introduction

The ETSI Broadband Radio Access Networks Project (EP-BRAN) is concerned with:

- broadband fixed radio access systems called HIPERACCESS;
- broadband radio local area networks (HIPERLANs); and
- broadband network-to-network point-to-point radio systems (HIPERLINK).

The present document deals only with requirements and architectures for HIPERACCESS systems.

HIPERACCESS systems will use fixed bi-directional radio connections to convey broadband services between users' premises and a broadband core network. HIPERACCESS is aimed particularly at residential customers and small businesses, where the economic benefits of using the shared radio medium are greatest. Radio access will be particularly useful to allow networks to be built economically by the competing telecommunications service providers of the future. The HIPERACCESS specifications will address radio access networks in the sense of the ETSI Global Mobile Multimedia (GMM) Report: radio access networks that are independent of and hence transparent to the various core networks in place today.

HIPERACCESS systems will be able to compete with, or complement, future wired broadband access systems (using, for example, digital subscriber loop or cable modem technologies), providing transport at up to 25 Mbit/s to the user's terminals. They will be capable of delivering Asynchronous Transfer Mode (ATM) transport, Internet Protocol (IP) service and video streams (amongst other broadband services); and support legacy services such as Plain Old Telephone Service (POTS) and Integrated Services Digital Network (ISDN) through appropriate user-network interfaces at a customer's premises. The customer need not be aware that the service is being provided via radio.

HIPERACCESS systems will primarily be deployed in "licensed" spectrum which is subject to a band plan and national licensing conditions which share spectrum between operators. However this will not specifically preclude their use in "licence-exempt" spectrum where there may be little or no co-ordination of frequency use.

A HIPERACCESS system will be capable of being deployed as an ITU-T Recommendation G.902-compliant [24] telecommunications access network, although in some implementations it may not meet all of the requirements of ITU-T Recommendation G.902-compliant [24].

HIPERACCESS systems are examples of a class of radio systems to be used for access to fixed premises and often described as Radio Local Loop (RLL). However, this common term is now deprecated by the International Telecommunications Union (ITU).

Clause 4 of this report gives an overview of HIPERACCESS. Clause 5 describes requirements of these systems, and system architectures are considered in clause 6. The degree of standardization is also discussed. HIPERACCESS standardization will define radio co-existence specifications which will be needed for administrations to allocate spectrum to HIPERACCESS operators, and ideally to obtain a uniform international HIPERACCESS frequency band. It should be compulsory for any HIPERACCESS system to meet the present document.

The present document will also include interoperability specifications, which would allow an operator to procure equipment from different suppliers which will interoperate. It is not clear yet whether such specifications should be mandatory: that is, whether administrations would only licence operation of conformant equipment in bands designated for HIPERACCESS. However, operators see advantages in such specifications being available and being therefore able to buy equipment competitively.

1 Scope

The scope of the present document is limited to the requirements and architectures for broadband fixed radio access networks, under the name HIPERACCESS.

The requirements in the present document address subjects such as applications, traffic volumes and traffic patterns that underlie the projected spectrum requirements; transport requirements, operational requirements and chosen architectures. The architectures address the communications layer models as well as the reference models that identify the key interfaces subject to standardization.

2 References

The following documents contain provisions which, through reference in this text, constitute provisions of the present document.

- References are either specific (identified by date of publication, edition number, version number, etc.) or non-specific.
- For a specific reference, subsequent revisions do not apply.
- For a non-specific reference, subsequent revisions do apply.
- A non-specific reference to an ETS shall also be taken to refer to later versions published as an EN with the same number.

- [1] EN 300 421: "Digital Video Broadcasting (DVB); Framing structure, channel coding and modulation for 11/12 GHz satellite services".
- [2] EN 300 429: "Digital Video Broadcasting (DVB); Framing structure, channel coding and modulation for cable systems".
- [3] EN 300 744: "Digital Video Broadcasting (DVB); Framing structure, channel coding and modulation for digital terrestrial television".
- [4] EN 300 789: "Electromagnetic compatibility and Radio spectrum Matters (ERM); Terrestrial Flight Telecommunications System (TFTS); Avionic termination radio testing specification".
- [5] EN 301 199: "Digital Video Broadcasting (DVB); Interaction channel for Local Multi-point Distribution Systems (LMDS)".
- [6] ETR 306: "Transmission and Multiplexing (TM); Access networks for residential customers".
- [7] ETS 300 019: "Equipment Engineering (EE); Environmental conditions and environmental tests for telecommunications equipment; Part 1: Classification of environmental conditions".
- [8] ETS 300 636: "Transmission and Multiplexing (TM); Time Division Multiple Access (TDMA) point-to-multipoint digital radio systems in the frequency range 1GHz to 3 GHz".
- [9] ETS 300 748: "Digital Video Broadcasting (DVB); Framing structure, channel coding and modulation for MVDS at 10 GHz and above".
- [10] ETS 300 800: "Digital Video Broadcasting (DVB); Interaction channel for Cable TV distribution systems (CATV)".
- [11] I-ETS 300 416: "Transmission and Multiplexing (TM); Availability performance of path elements of international digital paths".
- [12] I-ETS 300 465: "Broadband Integrated Services Digital Network (B-ISDN); Availability and retainability performance for B-ISDN semi-permanent connections".

- [13] ISO 8802.3: "Information technology; Telecommunications and information exchange between systems; Local and metropolitan area networks; Specific requirements; Part 3: Carrier sense multiple access with collision detection (CSMA/CD) access method and physical layer specification".
- [14] ISO 8802.5 (FDDI): "Information technology; Telecommunications and information exchange between systems; Local and Metropolitan Area Networks; Specific requirements; Part 5: Token ring access method and physical layer specifications".
- [15] ITU-R Recommendation F.557-4: "Availability objective for radio-relay systems over a hypothetical reference circuit and a hypothetical reference digital path".
- [16] ITU-R Recommendation F.697-2: "Error performance and availability objectives for the local-grade portion at each end of an ISDN connection at a bit rate below the primary rate utilizing digital radio-relay systems".
- [17] ITU-R Recommendation PS 837-1: "Characteristics of precipitation for propagation modelling".
- [18] ITU-T Recommendation E.800: "Terms and definition related to quality of service and network performance including dependability".
- [19] ITU-R Recommendation F.695: "Availability objectives for real digital radio-relay links forming part of a high-grade circuit within an integrated services digital network".
- [20] ITU-T Recommendation F.696-2: "Error performance and availability objectives for hypothetical reference digital sections forming part or all of the medium-grade portion of an ISDN connection at a bit rate below the primary rate utilizing digital radio-relay systems".
- [21] ITU-T Recommendation F.697-2: "Error performance and availability objectives for the local-grade portion at each end of an ISDN connection at a bit rate below the primary rate utilizing digital radio-relay systems".
- [22] ITU-T Recommendation G.821: "Error performance of an international digital connection operating at a bit rate below the primary rate and forming part of an integrated services digital network".
- [23] ITU-T Recommendation G.827: "Availability parameters and objectives for path elements of international constant bit-rate digital paths at or above the primary rate".
- [24] ITU-T Recommendation G.902: "Framework Recommendation on functional access networks (AN); Architecture and functions, access types, management and service node aspects".
- [25] ITU-T Recommendation I.355: "ISDN 64 kbit/s connection type availability performance".
- [26] ITU-T Recommendation I.357: "B-ISDN semi-permanent connection availability".
- [27] ITU-T Recommendation I.430: "Basic user-network interface; Layer 1 specification".
- [28] ITU-T Recommendation I.431: "Primary rate user-network interface; Layer 1 specification".
- [29] ITU-T Recommendation I.432: "B-ISDN User-Network Interface; Physical layer specification".
- [30] ITU-T Recommendation M.3010: "Principles for a Telecommunications management network".
- [31] ITU-T Recommendation Q.2140: "B-ISDN ATM adaptation layer; Service specific coordination function for signalling at the network node interface (SSCF AT NNI)".
- [32] ITU-T Recommendation Q.2144: "B-ISDN signalling ATM adaptation layer (SAAL); Layer management for the SAAL at the network node interface (NNI)".
- [33] TR 101 030: "Radio Equipment and Systems (RES); Radio Local Loop (RLL) Co-ordination Group; Survey of ETSI activities and recommendations for the ETSI work programme".
- [34] TR 101 190: "Digital Video Broadcasting (DVB); Implementation guidelines for DVB terrestrial services; Transmission aspects".

- [35] TR 101 274: "Transmission and Multiplexing (TM); Digital Radio Relay Systems (DRRS); Point-to-multipoint DRRS in the access network: Overview of different access techniques."
- [36] CEPT Recommendation T/R 52-01: "Designation of a harmonised frequency band for multipoint video distribution systems in Europe".
- [37] DAVIC: "Digital Audio-Video Council (DAVIC) 1.3; Part 8: Lower layer protocols and physical interfaces".
- [38] ETS 300 393-1: "Radio Equipment and Systems (RES); Trans-European Trunked Radio (TETRA); Packet Data Optimized (PDO); Part 1: General network design".
- [39] TS 101 113: "Digital cellular telecommunications system (Phase 2+); General Packet Radio Service (GPRS); Service description, Stage 1 (GSM 02.60 version 5.2.0)".
- [40] Council Resolution of 17 January 1995 on the lawful interception of telecommunications; Celex number 496Y1104(01); Official Journal of the European Union, No. C 329, 4 November 1996, pp 0001 - 0006.
- [41] Proceedings of the Full Service Access Networks conference, London, 20 June 1996.
- [42] ETS 300 347-1/A1: "Signalling Protocols and Switching (SPS); V interfaces at the digital Local Exchange (LE); V5.2 interface for the support of Access Network (AN); Part 1: V5.2 interface specification".
- [43] EN 301 005-1: "V interfaces at the digital Service Node (SN); Interfaces at VB5.1 reference point for the support of broadband or combined narrowband and broadband Access Networks (ANs); Part 1: Interface specification".
- [44] ATM Forum UNI 3.1 (1994): "User-Network Interface (UNI) specification version 3.1".
- [45] ATM Forum UNI 4.0 (1996): "ATM User-Network Interface (UNI) signalling specification version 4.0".
- [46] IEEE 1394 (1996): "Institution of Electrical and Electronic Engineers (IEEE) standard for a high performance serial bus".
- [47] USB: "Universal Serial Bus specification (USB) version 1".
- [48] <http://www.catv.org/modem/standards>

3 Definitions and abbreviations

3.1 Definitions

For the purposes of the present document, the following definitions apply:

cable modem: A device to provide communications services such as packet data transport on a cable TV network designed for broadcast services.

cloned: An informal term meaning a network component (for example a mobile handset) which has been programmed to impersonate another similar component legally connected to the network to obtain service or eavesdrop on traffic.

downlink: The data direction to an AT from an AP.

downstream: The data direction to a user from a core network.

statistical multiplexing: A method of time-division multiplexing data packets from multiple users into a shared channel in which randomly arising packets may be queued for varying periods so that the channel utilization may be kept high at the expense of variable transit delays for individual users.

uplink: The data direction from an AT to an AP.

upstream: The data direction from a core network to a user.

3.2 Abbreviations

For the purposes of the present document, the following abbreviations apply:

| | |
|-------------|---|
| 16QAM | 16 level Quadrature Amplitude Modulation |
| ADSL | Asymmetric Digital Subscriber Loop |
| AINI | ATM Inter Network Interface |
| AP | Access Point |
| APC | Access Point Controller |
| APT | Access Point Transceiver |
| ARQ | Automatic Repeat reQuest |
| AT | Access Termination |
| ATM | Asynchronous Transfer Mode |
| ATMF | ATM Forum |
| BER | Bit Error Ratio |
| BRA | Basic Rate Access (for ISDN) |
| BRAN | Broadband Radio Access Networks |
| CEPT | European Post and Telecommunications Consultative Committee |
| DCA | Dynamic Channel Assignment |
| DLC | Data Link Control |
| DS-CDMA | Direct Sequence Code Division Multiple Access |
| DVB | Digital Video Broadcasting |
| EDTV | Enhanced Definition TeleVision |
| EMC | ElectroMagnetic Compatibility |
| EMS | Element Management System |
| FDD | Frequency-Division Duplexing |
| FDMA | Frequency Division Multiple Access |
| FEC | Forward Error Correction |
| FH-CDMA | Frequency Hopping CDMA |
| GMM | Global Mobile Multimedia |
| GoS | Grade of Service |
| GPM | General Protocol Model |
| GRM | General Reference Model |
| GPRS | General Packet Radio Service |
| HDSL | High speed Digital Subscriber Loop |
| HDTV | High Definition TeleVision |
| HFR | Hybrid Fibre Radio |
| HIPERACCESS | HIgh PErformance Radio ACCESS network |
| HIPERLAN | HIgh PErformance Radio Local Area Network |
| IP | Internet Protocol |
| ISDN | Integrated Services Digital Network |
| ITU | International Telecommunications Union |
| IWF | InterWorking Function |
| LAN | Local Area Network |
| LDTV | Low Definition TeleVision |
| LLC | Logical Link Control |
| LMCS | Local Multipoint Communication Systems |
| LMDS | Local Multipoint Distribution System |
| LOS | Line Of Sight |
| MAC | Medium Access Control |
| MDUs | Multiple Dwelling Units |
| MMDS | Multichannel Multipoint Distribution Systems |
| MPEG2 | Motion Picture Experts Group type 2 |
| MVDS | Multipoint Video Distribution System |
| NC | Network Computer |
| NVoD | Near VoD |
| OA&M | Operations Administration and Management |
| OFDM | Orthogonal Frequency Division Multiplexing |

| | |
|-----------|--|
| P-MP | Point-to-Multipoint |
| PP | Point-to-Point |
| PABX | Private Automatic Branch eXchange |
| PC | Personal Computer |
| PHY | PHYSical (as in physical layer of a protocol) |
| PON | Passive Optical Network |
| POTS | Plain Old Telephone Service |
| PRA | Primary Rate Access (to ISDN) |
| PSTN | Public Switched Telephone Network |
| PTO | Public Telecommunications Operator |
| QoS | Quality of Service |
| QPSK | Quadrature Phase Shift Keying |
| RD-LAP | Radio Data-Link Access Protocol (a proprietary packet radio access protocol developed by Motorola) |
| RLL | Radio Local Loop |
| RR | Radio Relay |
| RSSI | Received Signal Strength Indicator |
| RT | Radio Terminations |
| SAP | Service Access Point |
| SDTV | Standard Definition TeleVision |
| SDU | Service Data Unit |
| SMEs | Small-to-Medium sized Enterprises |
| SNI | Service Node Interface |
| SoHo | Small office Home office |
| STB | Set-Top Box |
| STM-1 | Synchronous Transmission Multiplex - 1 |
| TCP | Transport Control Protocol |
| TDD | Time Division Duplex |
| TDM | Time Division Multiplex |
| TDMA | Time Division Multiple Access |
| TETRA-PDO | Trans European Trunked Radio - Packet Data Optimized |
| UNIs | User-Network Interfaces |
| VCI | Virtual Channel Indicator |
| VDSL | Very High Speed Digital Subscriber Loop |
| VoD | Video on Demand |
| VPI | Virtual Path Indicator |
| WWW | World Wide Web |
| xDSL | x (= generic) Digital Subscriber Loop |

4 Overview of High Performance Radio ACCESS network (HIPERACCESS) systems

HIPERACCESS systems are means by which mainly residential customers and small-to medium-sized enterprises can gain access to broadband telecommunications and data communications services, delivered to their premises by radio. These systems are intended to be able to compete with and complement other broadband wired access systems including x (=generic) Digital Subscriber Loop (xDSL) and cable modems. In this context "broadband" means "above 2 Mbit/s", and 25 Mbit/s is the competitive benchmark for HIPERACCESS systems.

This overview first covers the rationale for developing HIPERACCESS, by reference to alternative service delivery technologies that are expected to be available in the years 2000 to 2005. Then HIPERACCESS systems are introduced, with a working definition, their general characteristics and the general services to be supported. Finally, typical deployment scenarios for HIPERACCESS systems are considered. This discussion is given for background to the requirements of clause 5.

4.1 The rise of new telecommunications services and providers

The telecommunications service that many people now use in developed economies is about to change. The change may be slow or fast, but will happen for the following reasons:

- the likely rise in user demand for high-bandwidth packet-oriented services such as internet access, whose delivery over current low-bandwidth copper loops is adequate today but not optimal. This will lead to a situation where it is predicted that most of the total information communicated in future networks will be "data" rather than "voice";
- the likely rise in demand for stream-oriented services such as video, and mixed data, voice and video services (e.g. internet), that exceed the bandwidth of the conventional "local loop";
- the de-regulation of the telecommunications industry, creating pressure on new operators to innovate in service provision in order to compete with existing, traditional telephone service providers; and
- the response of the existing Public Telecommunications Operator (PTO)s to these scenarios.

The likely demand put forward in the first two of these points is currently weak but nevertheless present [41]. This is characteristic of a stage in market development where unfamiliar new services are offered and the market is not yet prepared or educated sufficiently to create a wide demand. It is point (c) that is likely to create the pressure - new service providers will promote demand for new services in order to create a business for themselves. In response to these new entrants, existing operators are also likely to develop and compete for these new markets in order to avoid losing their pre-eminent positions.

Multi-media applications and computer communications are often bursty in nature. Properly designed broadband systems allocate capacity to specific users "instantly", and given sufficiently large numbers of users take advantage of **statistical multiplexing** to serve each user adequately with a fraction of the bandwidth needed to handle the peak rate of all users simultaneously. The emergence of Asynchronous Transfer Mode (ATM) and Internet Protocol (IP) networks exemplifies this trend. The equivalent in the wireless domain would be an access system that is ATM or IP compatible and served many users with one or more broadband channels, the capacity of each being allocated on demand rather than on a fixed basis.

A typical user will expect to have an instantaneous high bandwidth available delivered by his access mechanism, but only occasionally. For example, he might expect a large document to be delivered very quickly so that he can start reading and digesting its contents. However, the period over which he is looking at the information in local storage means that the average bandwidth required to deliver a good service is low, even though the instantaneous bandwidth required is high. In this example, the average bandwidth required is constrained by the user's ability to read and assimilate information, but the instantaneous bandwidth required is dictated by the user's patience in waiting for complete documents to be delivered.

However, even in the new broadband world voice communications will remain essential. Broadband systems will have to support Plain Old Telephone Service (POTS) and Integrated Services Digital Network (ISDN) efficiently as well. Because of the continuing importance of narrowband communications, the ETSI Radio Local Loop (RLL) co-ordination group's report (TR 101 030 [33]) concluded that existing, narrowband, circuit-switched radio access system developments need to be continued where the market demand existed, unhindered by any attempt at additional standardization by ETSI. However, it also concluded that the foreseen rise in demand for broadband services would challenge existing narrowband radio local loop systems and proposed that ETSI should create a standard for broadband radio access. This led directly to the formation of the Broadband Radio Access Networks (BRAN) project.

Later in the present document the characteristics of several possible services which could be delivered over broadband access networks are reviewed. However there will be many other applications which have not even been envisaged today which will be enabled by a broadband access network. Although it is far from clear which of these applications are destined to emerge as the dominant market drivers, several alternative mechanisms which can deliver broadband services in a service-independent way have been identified. HIPERACCESS Networks complement, and compete with, this portfolio of access mechanisms.

4.2 Competing access mechanisms for the information age

Many mechanisms are now available, or will shortly be, for providing residential access to broadband telecommunications services. It is intended that the technical characteristics of HIPERACCESS systems be set with reference to other access systems which might be used to support broadband services, and which will represent the competition against which HIPERACCESS will have to compete in the years 2000 to 2005. ETR 306 [6] is a useful reference which catalogues access systems suitable for residential customers.

Taking account of the systems described in [6], and also including new developments, the following wired access systems address broadband access requirements to some degree:

- xDSL over copper pairs;
- cable modems over analogue or digital TV distribution systems;
- fibre to the building, kerb, cabinet or home; and
- electricity cables to the building carrying other services.

Some current and proposed wireless access systems also support broad band services or are useful examples:

- Point-to-MultiPoint (P-MP) radio relay systems as specified by ETSI TM4;
- Multipoint Video Distribution System (MVDS), Local Multipoint Distribution System (LMDS) and LMCS in the 28 GHz and 40 GHz bands;
- satellite systems; and
- radio packet access systems.

In wireless and wired access systems alike, bandwidth limitations exist in both the infrastructure and the access mechanism. The need to match the access bandwidth statistically to the needs of a population of users is perhaps most critical in the case of an information service provided using radio. However this need not diminish the overall service available compared to that available via alternative access mechanisms provided the system is properly dimensioned.

4.2.1 Wired access systems

4.2.1.1 xDSL over copper pairs

There are several Digital Subscriber Line (DSL) technologies, generically known as xDSL. Examples are High speed Digital Subscriber Loop (HDSL) (High-speed DSL), Asymmetric Digital Subscriber Loop (ADSL) (Asymmetric DSL) and Very high-speed Digital Subscriber Loop (VDSL), each of which is capable of providing a different data rate transport for high-bandwidth services over copper pairs, most of which can also trade bandwidth against distance.

VDSL systems will deliver between 6,5 Mbit/s and 26 Mbit/s of continuous bandwidth to each user on a standard copper pair. However, most systems using HDSL for delivery to the customer would inevitable have a bandwidth bottleneck at a higher level in the network (for example at the local switch).

Whilst the original development of HDSL provides a duplex symmetric service (normally at 2 Mbit/s) it does so at the cost of requiring multiple copper pairs (typically three). In most cases three pairs are not available from a switch to a large proportion of (in particular) residential customers' premises.

Technologies such as ADSL and VDSL only require a single pair but are designed to provide asymmetric bandwidth, much higher from the switch to the customer than in the other direction.

4.2.1.2 Cable modems

Cable modems are already being used in some parts of the world for providing access to the internet. In this case, the local cable plant and its multiple access protocol is a bandwidth bottleneck, in addition to that of any data communications backbone. Whilst the availability of bandwidth on a cable is not constrained in the same way as is radio spectrum on-air, there are still constraints resulting from the bandwidth of the cables and their distribution amplifiers, and the intermodulation products that occur.

Cable modems allocate one or a few video channels in the downstream direction on a small segment of the system, serving typically up to 200 homes. Users share this using a statistical multiplexing technique, with upstream data being sent in a narrower band upstream contention channel. The users typically have packet-mode access to an downstream data stream of between 2 Mbit/s and nearly 30 Mbit/s depending on the system; and contention access to an upstream bandwidth of perhaps 2 Mbit/s. Cable modems use modulation techniques and modems developed for digital video applications, and so are based on a transmission technology developed for mass-market applications [48].

It is obvious that cable modem systems incorporate a bottleneck, since data to and from users is statistically multiplexed in the dedicated channels serving the single segment. The frequency planning of older cable networks also leads to more serious restrictions in the data communications bandwidth that can be delivered to users.

4.2.1.3 Fibre to the building, kerb, cabinet or home

Today, a Passive Optical Network (PON) is the most common configuration for fibre in the access network. A PON is a tree-type branching structure with a common broadcasting transmitter, and a time-division multiplexed return channel. It thus has some aspects in common with cable systems. Very large splitting ratios (>10k subscribers) are now possible by using optical amplifiers.

Optical access technologies, e.g. PONs, are often used to feed other drop technologies such as coax/cable modems, twisted pairs/xDSL-lines, or even wireless systems. These systems are known as fibre to the kerb, cabinet etc. In these cases, an Optical Network Unit (ONU) terminates the optical line, and transfers the signal to some other drop technology for the last 100 m to 5 000 m, typically. An example is the use of Hybrid Fibre Radio (HFR), in which an optical fibre feeder system may be used to feed a number of radio cells. Radio base stations distribute the traffic to the end subscribers. In the simplest case, a PON (e.g. ATM-PON) can be used to feed the radio base stations. In order to reduce complexity and simplify maintenance, special transport feeder systems may carry the radio channels through the optical fibre at radio frequencies.

Alternatively, the fibre can be continued to the end user (fibre to the home). Due to the inherent bandwidth of the fibre, and the simple transmission protocols needed, several 100 Mbit/s bi-directional traffic can easily be delivered to the subscriber, if there is a need for it. However the present costs of optical components and the lack of obvious applications for such large bandwidths other than for large businesses militates against such deployments. As mentioned above, this mainly pushes the bottleneck higher up into the system, but the fibre would facilitate e.g. multiple wideband services, multiple operators etc., on the same shared medium.

4.2.1.4 Electricity cables to the building

Since an electricity supply cable enters virtually every building where a telecommunications service might be required, there is a strong motivation to use this cable for communications purposes. Until recently mains communications has been used for limited applications within homes (for example home security, appliance control, baby alarms); or for special control purposes in supply networks (for example controlling street lighting). Large bandwidth and long range transmission has been hampered by the poor quality of the communications path, which has a widely varying characteristic impedance and large noise levels caused by electrical switchgear, switched mode power supplies, and induced signals of various types.

More recently new, adaptive modulation methods and advanced error control have been applied to mains communications. This permits transmission over quite large distances, for example from a sub-station to the group of homes it serves, of bandwidths up to 1 Mbit/s with a limited capacity return path. The path remains intermittent (breaks occurring for example because of switchgear-induced splatter) so the communications is more appropriate for packet-mode services such as IP traffic.

In summary, mains communications has been developed to the point at which it appears capable of delivering quite a fast internet service to homes (up to 1 Mbit/s maximum burst rate) with a limited capacity reverse channel. It is unclear yet whether isochronous services will be supportable.

4.2.2 Radio access systems

4.2.2.1 Broadband point-to-multipoint radio relay systems

ETSI sub-technical committee TM4 is concerned with radio-relay systems, and prepares standards for Point-to-Point (PP) and P-MP equipment and antennas. TM4 standards specify the radio-frequency parameters of the equipment in such a way that spectrum management authorities and operators can plan the deployment of systems which will co-exist and provide the required quality of service for the operator combined with the maximum spectrum efficiency. TM4 standards do not define any elements of the protocol above the physical layer and do not enable inter-operability between conforming equipment from different manufacturers. TM4's P-MP standards have so far all been for radio access systems (including RLL) operating at the borderline between narrowband and broadband service. Most of these systems offer ISDN service, varying from basic rate (i.e. 144 kbit/s) to a single primary rate (i.e. 2 Mbit/s), although there are two work items, which are intended to offer higher than a primary rate ISDN access, namely:

- a standard for broadband point to multipoint radio system in the 24,25 to 29,5 GHz band, which will offer $n \times 2$ Mbit/s to a customer;
- a work item for a flexible broadband P-MP system, however that work item has been suspended in anticipation that the BRAN project will produce such a standard under its HIPERACCESS work item (and hence it is not listed in table 1).

Table 1: Standards currently in progress in TM4

| Subject of the standard | Status |
|---|--|
| P-MP equipment below 1 GHz for rural use | Still being drafted in TM4 |
| Time Division Multiple Access (TDMA) equipment, 1GHz to 3 GHz bands | Published; ETS 300 636 [8] |
| Direct Sequence Code Division Multiple Access (DS-CDMA) equipment, 1 GHz to 3 GHz bands | Completed Public Enquiry |
| Frequency Division Multiple Access (FDMA) equipment, 1 GHz to 3 GHz bands | Completed Public Enquiry |
| Frequency Hopping CDMA (FH-CDMA) equipment, 1 GHz to 3 GHz bands | Approved by TM4 |
| TDMA equipment, 3 GHz to 11 GHz bands | Completed Public Enquiry |
| DS-CDMA equipment, 3 GHz to 11 GHz bands | Approved by TM4 |
| FDMA equipment, 3 GHz to 11 GHz bands | Completed Public Enquiry |
| FH-CDMA equipment, 3 GHz to 11 GHz bands | Approved by TM4 |
| Antennas for P-MP equipment in 1 GHz to 3 GHz bands | Approved by TM4 |
| Antennas for P-MP equipment in 3 GHz to 11 GHz bands | Approved by TM4 |
| Antennas for P-MP equipment in 11 GHz to 60 GHz bands | Approved by TM4 |
| Broadband P-MP equipment in the 24,25 GHz to 29 GHz bands; five parts addressing various access methods | Some parts approved by TM4, others still being drafted |

TM4 has also produced an ETSI TR, giving a comparison among different access techniques for point to multipoint radio systems, which compares TDMA, DS-CDMA, and FDMA [35].

4.2.2.2 Microwave video distribution systems, DAVIC, and Digital Video Broadcasting (DVB)

a) Multichannel Multipoint Distribution Systems (MMDS), LMDS

MMDS and LMDS are very similar technologies initially designed for providing wireless distribution of video. In general, programming distributed by these systems comes to the system head-end from satellite or terrestrial feeds. Programme signals are multiplexed and re-broadcast to customer's premises by P-MP microwave links. The use of microwave frequencies makes it necessary for the antenna at the customer premises to be in LOS with the transmitter or a signal repeater.

Analogue MMDS systems are widely deployed in the US in the 2,5 GHz band, where the spectrum allocation allows for 33 analogue 6 MHz video channels. The reach is around 40 km, depending on antenna height. LMDS operates in the 28 GHz band with some 10 km LOS reach. These bands are not generally available in Europe for this purpose.

ETS 300 748 [9] specifies a digital broadcast system operating above 10 GHz which e.g. can be used in the 40,5 GHz to 42,5 GHz band. This band has been harmonized within CEPT for this purpose under CEPT Recommendation T/R 52-01 [36]. ETS 300 748 [9] uses the same Quadrature Phase Shift Keying (QPSK) modulation scheme as specified in EN 300 421 [1] for direct satellite broadcasting, in order to be compatible with the same Set-Top Box (STB) when used with a down-converter for the appropriate frequency band. It is referred to as a MVDS. DVB has also produced an LMDS specification EN 301 199 [5] that entered the public enquiry phase in December 1977. This specification is based on the interactive DVB cable specification ETS 300 800 [10] and uses FDM/TDMA multiple access in the uplink. Different uplink access modes are supported: reserved slots, reserved slots with dynamic reservation, contention slots and ranging slots. An uplink slot comprises a four byte unique word, an ATM cell (53 bytes), six bytes reed-solomon code and a one byte guard band. The uplink channel occupies 2 MHz bandwidth and supports a raw data rate of 3 088 Mbit/s and uses DQPSK modulation with $\alpha = 0,3$. For the downlink, in-band signalling and out-of-band signalling are supported. In-band signalling is preferred, i.e. the signalling is transported in a broadband channel, according to ETS 300 748 [9].

DVB has also produced a digital broadcast MMDS specification EN 300 789 [4], applicable below 10 GHz, which is based on the broadcast specification EN 300 429 [2].

A new ITU-T study group 9 has started studying the physical distribution of MMDS services and possible harmonization with SMATV and cable TV distribution under Q.18/9. A new ITU-T Recommendation is being drafted.

b) DAVIC - 'PHysical (as in physical layer of a protocol) (PHY) on MMDS' , 'PHY on LMDS'

DAVIC has also started work on MMDS and LMDS in the context of the DAVIC specification [37].

DAVIC addresses a physical layer interface supporting unidirectional digital transmission over radio frequencies (up to 10 GHz): 'PHY on MMDS'. This physical interface describes the frame structure, channel coding and modulation for the carriage of Motion Picture Experts Group type 2 (MPEG2)-streams.

DAVIC 1.1 also addresses a physical layer interface supporting bi-directional digital transmission over millimetric radio waves (above 10 GHz): 'PHY on LMDS'. This interface is a P-MP Time Division Multiplex (TDM)/TDMA with a QPSK and/or 16 level Quadrature Amplitude Modulation (16QAM) modulation. Two frame structures are provided for downlink data transmission, one for MPEG2 transport streams and the other for ATM-cell-transfer. An ATM-cell-transfer frame structure is provided for the uplink data transmission. Medium Access Control (MAC) messages, protocols and tools are also described in this specification in order to establish, maintain and manage the physical layer and the access control.

DAVIC does not address a common air interface, or give any indication on frequency bands to be employed because this would be a decision of any country administration. Rather it defines a "Common Intermediate Frequency Interface" specification. The DAVIC LMDS specification can be applied at both the 28 GHz (LMDS) and 40 GHz (MVDS) bands.

c) DVB - Terrestrial broadcasting

Guidelines for the implementation for DVB terrestrial services will shortly be published as TR 101 190 [34]. A specification for a baseline transmission system for digital terrestrial television broadcasting has been approved by DVB and is published by ETSI as EN 300 744 [3]. This En specifies the channel coding/modulation system intended for digital multi-programme low, standard, enhanced and high definition television (Low Definition TeleVision (LDTV), Standard Definition TeleVision (SDTV), Enhanced Definition TeleVision (EDTV) and High Definition TeleVision (HDTV)) terrestrial services. It identifies the global performance requirements and features of the baseline system, in order to meet the service quality targets.

The system is directly compatible with MPEG-2 coded TV signals. It has been designed for 8 MHz channels although an adaptation to 6 MHz and 7 MHz can easily be achieved by scaling down the various parameters, changing the clock frequency. Two modes of Orthogonal Frequency Division Multiplexing (OFDM) operation are defined: a "2k mode" and an "8k mode". The "2k mode" is suitable for single transmitter operation and for small Single Frequency Networks (SFNs) with limited transmitter distances. The "8k mode" can be used both for single transmitter operation and large SFN networks. Simulcast based on hierarchical channel coding and modulation is also considered to cover e.g. specific coverage and/or portability issues. QPSK, 16-QAM and 64-QAM are proposed for different code rates (1/2, 2/3, 3/4, 5/6 and 7/8) and guard intervals (1/4, 1/8, 1/16 and 1/32) offering a wide range of possible useful bit rates from 4,98 Mbit/s to 31,67 Mbit/s.

4.2.2.3 Satellite systems

Geostationary satellite systems already provide analogue broadcast television channels to many residential subscribers, and digital services are now being introduced. Some of the digital downlink channels can be dedicated to a broadband IP service and shared among several subscribers. The users then request content from the Internet via their Public Switched Telephone Network (PSTN) line and get it at a higher speed via the satellite downlink channel. A next phase will consist to provide the request channel via a satellite uplink (with a bit rate limited to 128 kbit/s). The system architecture would allow the head-end to choose to route a downlink stream either to the PSTN network or to the satellite according to the expected traffic (through the PSTN network for low amounts of data and through the satellite for high amounts) in order to optimize the satellite capacity usage.

Versions of the DVB standards have been developed, optimized for satellite transmission.

New satellite systems are expected to be launched in few years providing bi-directional bandwidth on demand to business (up to a few megabits per second) and residential users (typically up to 512 kbit/s) almost everywhere in the world. Some of these systems will use a constellation of several tens or hundreds (depending upon the chosen technology) of low earth orbit satellites whereas other systems will rely on several geostationary satellites.

The strength of satellite broadband access does not lie in capacity but in its global coverage.

4.2.2.4 Radio packet access systems

A number of radio systems have been deployed which specifically provide packet data access. These include mobile data systems such as mobitex and Radio Data-Link Access Protocol (RD-LAP); and the ETSI standard Trans European Trunked Radio - Packet Data Optimized (ETS 300 393-1 [38]). A new bearer service is also being specified within the GSM family of specifications - General Packet Radio Service (TS 101 113) [39]. These mobile data systems are primarily intended for supporting true mobility and high bit-rate is secondary.

With the growth of more flexible and cost effective internet accesses some companies have started to offer proprietary wireless internet access networks. These systems may not be fully compliant with any recognised standard.

4.3 HIPERACCESS - market positioning

Reviewing the access technologies described above, a number of conclusions may be drawn.

- VDSL and cable modem systems are applicable by operators wishing to upgrade existing wired networks (copper pair or coaxial systems respectively). They are able to support a bit rate of 25 Mbit/s to the user but generally a significantly lower upstream bandwidth. Both technologies would require a new operator to install new physical cable plant at considerable expense. Passive optical networks can be extended direct to the customer and in principle can deliver significantly larger bandwidth, but again requires installing new physical cable plant. Mains communications can be overlaid on existing power wiring but performance is restricted.
- The "TM4-type" broadband P-MP technologies are primarily designed for providing radio distribution of $n \times 2$ Mbit/s circuits to businesses, and the needs of low-cost high-volume manufacture for residential and small business applications have not been considered in the design. Many of the actual systems covered by these coexistence standards are explicitly designed to support circuit-mode transmission at some multiple of 64 kbit/s (although some more recent systems are being designed for ATM access). TM4 standards do not specify any radio parameters other than those needed for radio coexistence.
- MMDS and LMDS systems are primarily designed for video distribution and assume that the bandwidth requirements will be quite asymmetric between up-stream and down-stream - viewers want to choose from a wide selection of channels but the associated upstream traffic bandwidth is small. More recent developments, particularly in the DAVIC and DVB fora, are generalising the types of information which can be distributed but the asymmetry remains - such systems are at best likely to provide service bandwidths similar to HDSL and cable modems.

- Satellite systems are widely used today to broadcast video and these systems are being updated for digital transmission including distribution of IP with limited bandwidth particularly upstream, based again on the DAVIC type models. There are also developments of two-way satellite access systems focusing on very-wide-area mobility. In general whilst satellite systems can support high peak bandwidth to a single user they are unlikely to be able to compete with wired broadband systems such as VDSL or cable modems for serving high user densities.
- There are a wide range of radio standards and systems developed and deployed which specifically provide packet access. These range from traditional "mobile data" systems to newer systems specifically designed for internet access at higher speeds. None of these approach the performance of wired broadband access systems.

Against this background, HIPERACCESS is conceived to compete directly with HDSL and cable modems. It will provide a high peak bandwidth to a fixed user; support high bandwidth communications equally to and from the user; and be viable for mass market applications with reasonably high user densities.

4.4 Target network economics

HIPERACCESS networks will be attractive to operators (compared to deploying wired systems) for mainly economic reasons, which include the following:

- A radio access system can provide **coverage** of potential residential and small business customers at relatively low cost. Thus the cost of market entry is reduced compared to a cable network which has to pass each customer to which service is to be offered before any service can be marketed. Alternatively, radio can be deployed to target economically-attractive customers.
- For a radio access system, a high proportion of the investment in a mature system can be in the radio terminations on customer premises. This part of the investment is essentially proportional to customer numbers. Thus investment in a radio network can be very incremental. In contrast, the total investment in a cabled network is almost independent of the proportion of "passed" customers taking the service.
- Radio networks may be rolled out quickly, allowing the operator to introduce service earlier and therefore to generate a revenue stream more quickly to offset fixed operational costs.
- Radio systems are not subject to disturbance by civil works which results in high on-going repair costs for a cabled network. (However there are environmental effects on radio, from new building work and foliage growth for example, which have an analogous, but much smaller, effect).
- Radio systems may be used in order to provide service to customers sited in areas which are difficult to serve by other means.

It is worth noting that HIPERACCESS networks will be most useful to operators who do not have a wired network which they could upgrade with xDSL or Cable Modems. If such a network exists, then some of its economic characteristics (incremental investment with growth of customer demand) are similar to those of radio access. Thus a reasonable reference point for the target cost for a HIPERACCESS system would be the "cost per home passed" and "incremental connection cost" for these upgrade technologies.

4.5 Working definition of HIPERACCESS

For the purposes of the present document a HIPERACCESS system is defined with reference to the simplified reference model in figure 1.

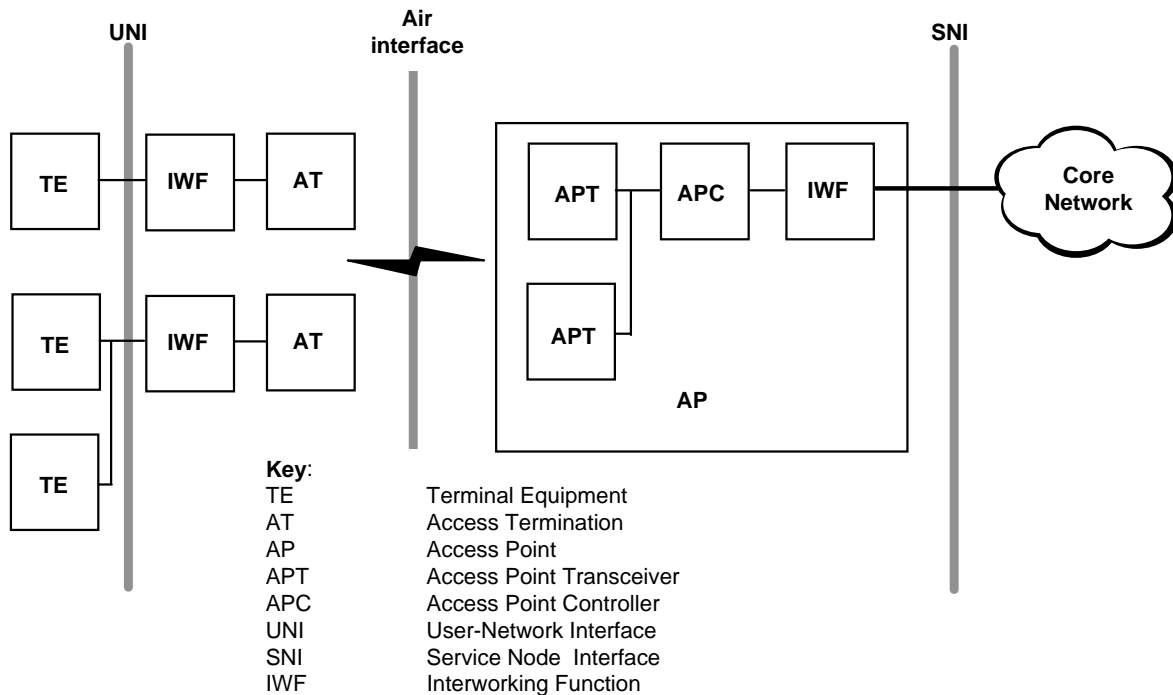

Figure 1: Simplified HIPERACCESS reference model

HIPERACCESS is a radio access system which may be deployed to connect User-Network Interfaces (UNIs) located in and physically fixed to customer premises, to a Service Node Interface (SNI) of a broadband core network, characterized as follows:

- The target users are residential households, or typical Small-to-Medium sized Enterprises (SMEs).
- The radio system will be capable of providing users with a peak one-way (up-link or down-link) information rate of at least 25 Mbit/s at the UNI, accessed using appropriate standardized packet protocols such as ATM or IP.
- HIPERACCESS systems must support both symmetric and asymmetric data flows, which may be duplex or simplex. A duplex symmetric flow could be one or several (from for example a Private Automatic Branch eXchange (PABX)) 64 kbit/s circuits carrying telephone calls, or circuit-mode videoconference connections. A simplex symmetric flow could be the download and upload of files. A simplex asymmetric flow could be downloading a Web page or a video sequence.
- It is assumed that the system will use multiple access to the radio bandwidth in order to optimize the efficiency with which multiple "bursty" users utilize spectrum.
- The radio system must also efficiently support legacy services, specifically POTS and ISDN (possibly over the native ATM or IP network service in a standardized way).
- Systems may be deployed by PTOs who provide network services to the public, or private operators who use the network for their own purposes. PTOs require their own licensed spectrum to ensure they can give QoS guarantees. Private operators may deploy the system in licence-exempt bands.
- It follows that the HIPERACCESS standard must be capable of operating in a number of designated frequency bands over a wide range, probably from 3 GHz to 60 GHz. The service delivered may be compromised by the amount of bandwidth available at any given operating frequency.

4.6 Multiple access, statistical multiplexing

A HIPERACCESS radio access system creates a pool of bandwidth within a radio coverage area. This bandwidth is shared between all of the subscribed users present. In principle, all of the bandwidth may be used by one user, or shared according to some multiple access scheme amongst all of the users demanding bandwidth. In fact, the uplink and downlink directions for each user may demand bandwidth separately up to their individual or combined limits, if any.

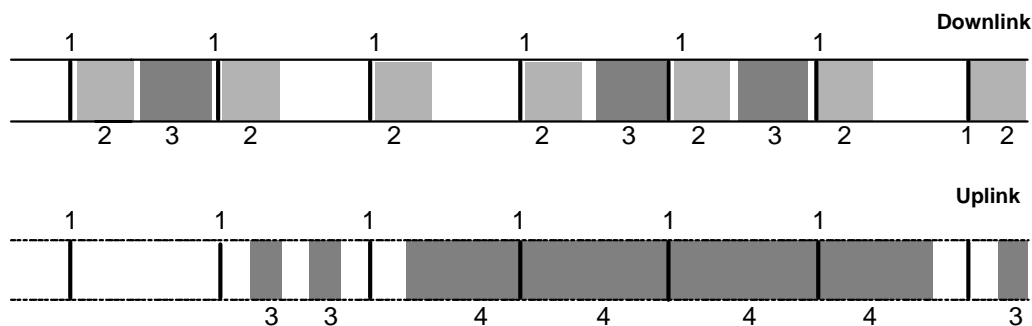

Figure 4.2: Outline of statistical multiplexing

Figure 4.2 shows an outline of statistical multiplexing in operation. Two radio carriers are represented, a continuous modulated downlink from a single AP and a "bursty" uplink from several AT. The scenario shown includes several types of interaction.

- 1) The up- and down-link bursts labelled **1** are from a termination involved in a single isochronous 64 kbit/s duplex call. It transmits regular short data bursts on the uplink and receives corresponding short segments (cf. "timeslots") in the downlink. This mode is equivalent to conventional TDM/TDMA.
- 2) The downlink bursts labelled **2** are a single 2 Mbit/s MPEG encoded video stream. Since this is a simplex service there is no corresponding uplink data.
- 3) The irregular downlink bursts labelled **3** are World Wide Web (WWW) page data being downloaded to a terminal running a web browser. The uplink bursts labelled **3** would typically be mouse pointer data or Transport Control Protocol (TCP) acknowledgements.
- 4) The long uplink burst **4** is a long data segment from a web server connected via HIPERACCESS, segmented to allow for the short segments of isochronous data **1**.

Fundamental to the operation of the scheme is the fact that an application which only needs low average bit-rate nevertheless uses the maximum available bit-rate while it has access to the channel. The higher the channel bit-rate the more efficient statistical multiplexing becomes.

Not evident in the scenario is that the different types of data have different priorities. Thus the speech and video information is inherently being used by applications that assume that new data is available continuously and isochronously, and therefore the system must not introduce varying delays. However, the web data is not time critical and can be delayed and if necessary queued either in the AP or AT while the air interface is busy. By these means the air interface mixes the different data streams together and can, if well designed, achieve high utilization and give all the users acceptable quality of service for their applications.

It might be inferred from the diagram that frequency-division **duplexing** (Frequency-Division Duplexing (FDD)) is mandatory. The picture shows the uplink and downlink flows as separate, but they could be duplexed in frequency or time (Time Division Duplex (TDD)). If FDD is used some bandwidth may be "wasted" if the aggregate flow bandwidths uplink and downlink are different; TDD enables a given radio bandwidth to be shared flexibly between uplink and downlink.

The scenario shown obviously uses time-division to allow data from different users to be **multiplexed** on the air. However, in a radio system obviously other multiplexing domains may be exploited as well: conventionally **frequency**, **code**, and **space**. However it is obvious that the fundamental possibility of statistical multiplexing arises because of the stochastic nature of at least some of the signals with respect to **time** and therefore these other multiplexing domains are likely to be ancillary. They should however be considered: for example spread-spectrum multiplexing might be used in the "up" direction to "soften" multiple-access contention, whilst frequency division could be used to decrease co-channel interference between neighbouring service areas.

4.7 Service support

4.7.1 Service transparency and service independence

An operator using HIPERACCESS should be able to provide a similar set of bearer services and a similar grade of service to his competitor using VDSL or cable modems, though there may be limitations on the penetration of the potential user base which can be served.

HIPERACCESS will provide service transparency and be service independent. To ensure service transparency, the performance of the system should be such that the application behaviour will be the same as on a wired system of equivalent bandwidth. To be service independent, the system behaviour should be independent of the information types being transported.

The system will be capable of providing high bit-rate services with variable symmetry and transfer rates, as needed to support ATM and future applications of IP. It will also be capable of efficiently providing "toll quality" POTS and ISDN.

4.7.2 Typical customer applications

Broadband fixed radio access networks have to be flexible enough to support a wide range of applications in use today and to support future services. The main user applications that can be foreseen today are as follows:

- internet access;
- home working;
- Local Area Network (LAN) emulation (i.e. connecting remote workstations to LANs via routers and PP links);
- video-telephony and video conferencing;
- real time video (the degree to which it is economical to offer video distribution services will depend on the required video quality, spectrum availability, the economics of the HIPERACCESS system and subscriber densities);
- real-time audio; and
- computer gaming.

In addition to the above broadband applications, HIPERACCESS will include support for existing narrowband applications:

- voice (using 64 kbit/s and lower rate code(s));
- legacy voice-band modems (including fax); and
- narrowband ISDN.

4.7.3 Bandwidth

Table 4.2 lists the bandwidth requirements for applications of broadband access by market sector, distilled from the general requirements illustrated above.

Table 4.2: Requirements for access bandwidth by market sector

| Market sector and applications | Peak data rate (bit/s) |
|---|---------------------------|
| Residential narrowband service (POTS and ISDN Basic Rate Access (BRA)) | 32k to 144k |
| SME service (POTS, ISDN Primary Rate Access (to ISDN) (PRA), LAN interconnect) | 2M to 25M |
| Large enterprise service (ISDN PRA, LAN interconnection, Leased lines, etc.) | 25M to 155M (see note) |
| Public safety/utility (Network disaster recovery, multimedia kiosks, wideband telemetry, etc.) | 2M |
| Consumer electronic commerce (Transaction processing, home banking, targeted marketing, interactive advertising, etc.) | 2M to 8M |
| Residential entertainment (Internet, digital audio/video programming, Video on Demand (VoD), HDTV, etc.) | 2M to 25M |
| Educational/medical (Corporate training, distance education, telemedicine, etc.) | 2M to 25M |
| Telecommuting support (LAN interconnect, multipoint video conferencing, etc.) | 2M to 25M |
| NOTE: Large enterprises may have high bandwidth requirements for corporate telephony and corporate data network interconnection. The bandwidth is also in use for long periods because the organizations have internal network equipment such as PABXs and routers which "concentrate" traffic. The "large enterprise" market sector is therefore regarded generally as outside HIPERACCESS' scope, because the bandwidth required may be too large and the efficiencies of statistically multiplexing traffic on a shared air interface are small. | |

The table states the overall peak bandwidth required. However, this bandwidth may be required in both directions (for example for telephone or videophone/videoconference calls); to the customer's premises (for example for viewing video, or downloading large files from a corporate LAN server); or from the customer's premises (for example web server access or file transfer from a corporate LAN server). In general there may be data flows to and from customers' premises with different bandwidths in both directions. In addition within the premises several users sharing the same subscription (e.g. the members of a family or the employees of a company) may be running several applications (e.g. in a family, using the 'phone, watching television, accessing the internet) and each application may have different data flow characteristics. The data rates shown above are those for the total of all the applications from the premises.

4.8 HIPERACCESS deployment

This subclause describes examples of how HIPERACCESS may be deployed to serve various users and areas. The deployment configurations outlined below are for-example only and should not be regarded as exclusive.

It is tempting to consider HIPERACCESS systems in similar configurations to mobile cellular systems, however this may not be the case and it is important not to think in this constrained way. Specific "non-cellular" deployments shown below include the use of repeaters to fill-in coverage in hard-to-get-to locations where it is cheaper to provide a repeater site that has only a power feed and no network connection; and the concept of being able to take service from multiple base stations, to account for varying propagation conditions. These features may not be needed at the lower radio frequencies, say around 3 GHz, but at higher frequencies, say 40 GHz, may be essential to obtaining a high percentage of reliable coverage over a service area.

4.8.1 General

A HIPERACCESS system will be capable of deployment over an area that is in principle unlimited (such as a large city). It will only provide fixed services; that is, the AT to which users' terminals are connected are permanently fixed to the structures of buildings.

The system will be economically viable in low to medium penetrations (1% to 20%) of households and SMEs in typical semi-rural, suburban, urban and dense urban environments in most of the world, taking account not only of the costs of AP and ATs but any necessary links connecting the APs to (e.g.) switches. In practice this means that a high proportion of the network investment should be in the customer termination equipment.

The system should be flexible and efficient so that it can support several configurations, for example:

- one AT supporting several applications in several attached terminals;
- one AT supporting one customer; or several customers in the same premises who would have separate subscriptions (for the purposes of billing, service management, and fault management for example).

The system will also meet the needs of small and medium size enterprises who usually require communications bandwidth at a different time of the day from residential users and can therefore efficiently share network infrastructure. This may be aided by incorporating means to re-configure the network to "move" capacity to different areas depending on traffic load distribution.

4.8.2 Example deployment configurations

Figure 4.3 shows an example deployment configuration of HIPERACCESS. The AP (the base station) can serve individual buildings, multiple subscribers in multiple buildings (using multiple radio links), or multiple subscribers in a single building by use of a single radio link and further in-building distribution systems.

NOTE: It should not be assumed that all the interfaces shown in figures 4.3 and 4.4 will be subject to HIPERACCESS standardization.

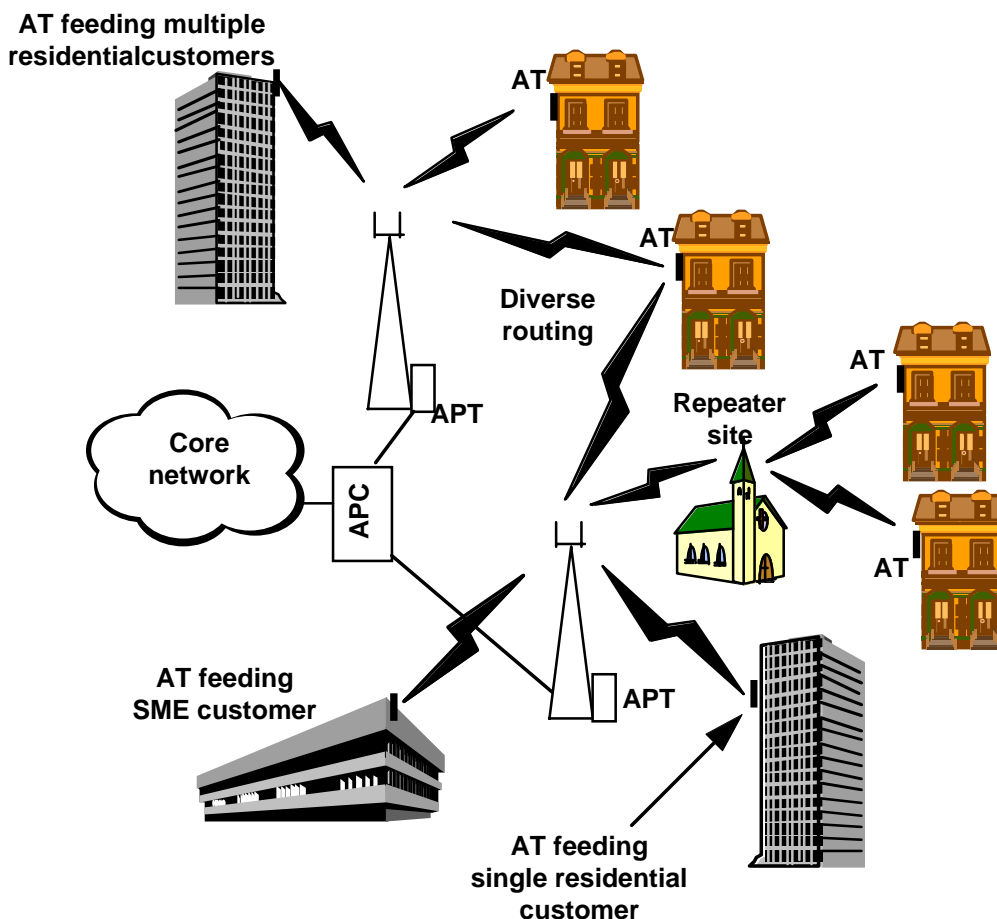

Figure 4.3: A typical deployment configuration

Figure 4.3 above shows the use of a repeater and route diversity in order to fill-in coverage in difficult areas. This does not imply the use of these features in all types of HIPERACCESS system. However it does require the capability to implement them if required, and leave them out if not.

The use of sectorisation at an AP is not shown here, but may be expected in many cases. Sectorisation is used for several reasons. First, at microwave frequencies it becomes impossible to make a practical omni-directional antenna, and in any case its omni-directional pattern would be destroyed when mounted on a mast. Second, sectorisation may be used to improve frequency re-use and hence system capacity. Third, sectored antennas have higher gain and may improve range. One sector would be fed from at least one Access Point Transceiver (APT). In rare cases an APT may illuminate more than one sector through a passive splitter (for example when only limited sectors of the field of view are inhabited and likely user density is low).

The core network in figure 4.3 could be ATM, IP, PSTN/ISDN, or a combination (with suitable interworking units).

4.8.3 Interfaces at the customer premises

At the user or customer end, the interface to the customer's equipment will not be explicitly specified by HIPERACCESS. It could be any one (or more) of the many existing and future (perhaps standardized) interfaces. The air interface protocol is interworked to the interface(s) in use. This approach allows the implementation of a wide range of options to fit specific customer needs.

A few examples are described here (with reference to figure 4.4), but clearly they do not represent the full set of possibilities.

Within individual dwelling units:

- simple connection to a Personal Computer (PC), Network Computer (NC) or peripheral via standardized interfaces (e.g. Ethernet, USB, IEEE 1394, ATM etc.);
- connection to common residential entertainment equipment such as a STB, digital TV, HiFi or games console. This may be through one of the interfaces above, or otherwise;
- analogue telephone or ISDN terminal through suitable terminal adapter;
- further short range wireless network within the unit (for example HIgh PErformance Radio Local Area Network (HIPERLAN)); and
- a combination of the above.

Serving Multiple Dwelling Units (MDUs):

- distribution to each individual residence, via a per-residence antenna; or a single AT and an in-building distribution network;
- use one radio link to a large building and then further wired distribution to individual residences within the building;
- further short range wireless network within the building (for example HIPERLAN); and
- connection to narrowband mux. or concentrator within building.

Business customers:

- connection to router and LAN;
- connection to PABX; and
- further short range wireless network within the building (for example HIPERLAN).

It is not required that the HIPERACCESS standards will define how all these interfaces will be supported. Rather, interworking definitions should be developed for a limited set of standard network layer protocols (e.g. ATM, IP), so that standardized methods of supporting other interfaces can be called on.

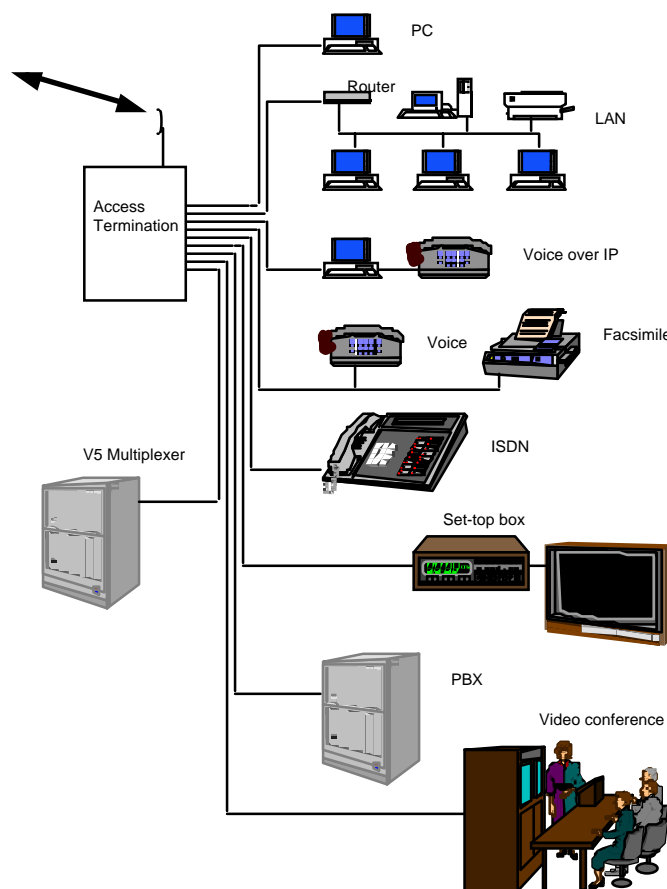

Figure 4.4: Customer interface functionality (examples)

4.9 Miscellaneous issues

The HIPERACCESS system design should also consider the following issues:

- it should support standard user-network interfaces;
- while network management should follow standard TMN principles, the specific needs of access and radio systems should be taken into consideration;
- customer equipment especially should be cheap to implement;
- efficient use of appropriate frequency bands to enable operators to meet availability, QoS and Grade of Service (GoS) requirements economically;
- it should be transparent to billing (or at least make no limitation of billing options);
- equipment should be easy to install, in particular the ATs in customer premises;
- requirements for frequency planning should be minimized, though it should be possible for an operator to manually intervene to optimize frequency re-use;
- smooth upgrade of network capacity from initial "coverage-dominated" to eventual "capacity dominated" roll-out; and
- the difficulty of obtaining LOS for propagation at microwave frequencies and the desirability of standardized functions such as repeaters to enable more economical coverage and the high availability required for fixed services.

The needs of established public telecommunications operators, new public telecommunications operators and private network operators should be considered.

5 Requirements

Requirements may be of three types:

- end-to-end (i.e. UNI to UNI) requirements for networks including a HIPERACCESS system;
- requirements to be met by the complete HIPERACCESS system at or between its external interfaces; and
- requirements to be met by sub-systems within a HIPERACCESS network.

These requirements do not explicitly address any end-to-end requirements except in the context of setting the requirements for complete HIPERACCESS systems. These requirements are generally set within specifications that are outside the scope of the BRAN Project.

The requirements are generally defined using the terminology introduced informally in figure 4.1.

There are some general requirements for complete HIPERACCESS systems.

- Logically at least, a HIPERACCESS system should be capable of replacing an ITU-T Recommendation G.902 [24] - compliant wired access network. Therefore it should comply with ITU-T Recommendation G.902 [24] wherever appropriate. This may not need to be strictly enforced, and some requirements of ITU-T Recommendation G.902 [24] may be inappropriate for certain types of broadband access network and service type.
- HIPERACCESS information transport shall be service independent. That is, the HIPERACCESS system shall not (need to) know about the precise nature of the traffic it carries.
- Where appropriate, HIPERACCESS shall conform to a service contract on a connection-by-connection basis (e.g. for ATM connections). The available service contracts, their data rates and the QoS parameters to be supported shall be specified.
- It is not envisaged that an AT shall be moved once it has been affixed to subscribers' premises.

5.1 External interfaces, and network management

A HIPERACCESS network has three external interfaces (see figure 5.1), the SNI, the **user-network interface** (UNI) and the **management interface**. It may actually be connected to multiple service nodes and/or to multiple user-network interfaces.

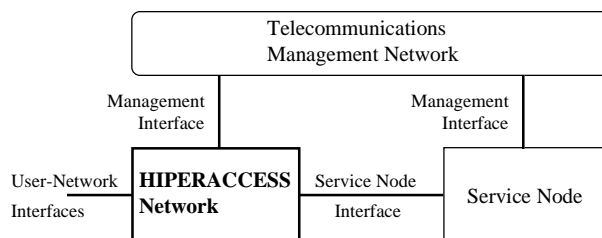

Figure 5.1 HIPERACCESS interfaces

In HIPERACCESS the UNI will be supported at an AT, (see figure 4.1). A single AT should be able to support several UNIs, for example a 100BaseTX Ethernet PC interface; a POTS or ISDN interface for telephony; and a DAVIC [37] interface to a video set-top box.

The HIPERACCESS standard will define how a range of standardized interfaces are supported for interoperation with other networks (see table 5.1).

Table 5.1 Standardized HIPERACCESS interfaces

| Supported Service | Service Node Interface | User Network Interface | Comments |
|-------------------|---|--|--|
| PSTN | - ETS 300 347/A1 [42] - EN 301 005-1 [43] | POTS (national standards) | |
| N-ISDN | - ETS 300 347/A1 [42] - EN 301 005-1 [43] | - ISDN BRA (ITU-T Recommendation I.430 [27]) - ISDN PRA/2 048 kbit/s (ITU-T Recommendation I.431 [28]) | |
| B-ISDN ATM | - EN 301 005-1 [43] - ATM Forum (ATMF) NNI (ITU-T Recommendation Q.2140 [31] /ITU-T Recommendation Q 2144 [32]) - FDDI (ISO 8802.5 [14]) - ATMF ATM Inter Network Interface | - B-ISDN/2 048 kbit/s (ITU-T Recommendation I.432 [29]) - ATM UNI 4.0 [45], UNI 3.1 [44] - Ethernet (ISO 8802.3 [13]) on 10baseT and 100baseTX - DAVIC [37] | ATM as an end-to-end transport mechanism carrying an unspecified service |
| IP | - ETS 300 347/A1 [42] - EN 301 005-1 [43] - ATMF NNI (Q.2140/4 [30], [31]) - FDDI (ISO 8802.5 [14]) - UMTS | - Ethernet (ISO 8802.3 [13]) on 10baseT and 100baseTX - IEEE 1394 [46] and USB [47] - ATM UNI 4.0 (AAL5 UBR) [45] - DAVIC [37] | |
| UMTS | - UMTS | As above | As defined by the ETSI GSM/UMTS Project. SMG3 |

An open standard protocol should be used by the management entity of the HIPERACCESS system to interface to the external network manager of the operator. Generally, the network management interface requirements should follow the guidelines of ITU-T Recommendations G.902 [24], M.3010 [30], and the ETSI V5 and VB5 series of recommendations where applicable [42] and [43].

For HIPERACCESS systems conforming to interoperability standards the following network management guidelines should be followed:

- as an over-riding requirement, it should be possible to provision and operate an AT provided by one supplier on an AP provided by another;
- remote and local test, configuration, and software download should be supported;
- a standardized interface should be defined for local management (i.e. not over the air) at the AT;
- a standardized set of MIB information elements should be defined to permit at least a basic level of interoperation of ATs with APs;
- any radio relay or repeater function should be a managed element; and
- specific needs of radio network management should be considered and defined as appropriate.

5.2 HIPERACCESS transport requirements

Within a HIPERACCESS network, requirements may be put on all of its sub-systems. Furthermore, complete end-to-end network requirements must be met for acceptable levels of user service. Here we derive the HIPERACCESS network's transport requirements, that is between the service node interface and the user-network interface. In order to identify those requirements, we consider a top down approach from the application characteristics down to the access network transport requirements.

5.2.1 Transparency

The behaviour of a user's application connected through HIPERACCESS shall be indistinguishable from that of the same application connected through a wired broadband access network.

5.2.2 Service independence

A HIPERACCESS system must not need to have information on the type of application information being carried to transport it correctly.

5.2.3 Throughput requirements

Table 5.2 lists the desired characteristics for some specific applications that are to be transported. Although HIPERACCESS must be service-independent they are listed to allow the transport requirements of the network to be derived.

Table 5.2: Characteristics for broadband access by application

| Application | Downstream data rate (bit/s) | Upstream data rate (bit/s) | Transfer Mode (note 6) | Mean transit delay (ms) (note 7) | Maximum transit delay variation |
|--|------------------------------|----------------------------|------------------------|----------------------------------|---------------------------------|
| Telephony (PSTN) | 64 k max. (note 9) | 64 k max. (note 9) | Circuit Oriented | 10 (note 1) | ≈0 (note 1) |
| N-ISDN | 64 k to 1 920 k | 64 k to 1 920 k | Circuit Oriented | 10 (note 1) | ≈0 (note 1) |
| High quality video conference (note 2) | 1,5 M to 6 M | 1,5 M to 6 M | Circuit Oriented | tbd (note 2) | ≈0 (note 2) |
| VoD | 1,5 M to 6 M (HDTV: 25M) | Packet mode (note 3) | Circuit Oriented | 300 | ≈0 (note 4) |
| Near VoD (NVoD) | 1,5 M to 6 M (HDTV: 25 M) | Packet mode (note 3) | Circuit Oriented | 300 | ≈0 (note 4) |
| WWW browsing | 10 M | 1 M (note 8) | Connection-less | 10 | approx. 100 |
| WWW serving | (note 5) | (note 5) | Connection-less | 10 | approx. 100 |
| Remote access to corporate data network | 25,6 M (note 5) | 25,6 M (note 5) | Connection-less | 10 | approx. 100 |
| LAN Interconnect | 25,6 M (note 5) | 25,6 M (note 5) | Connection-less | 10 | approx. 100 |
| <p>NOTE 1: For telephony service echo cancellers are needed if the round-trip delay exceeds critical values (which are generally functions of the national network). Beyond a round-trip delay of 100 ms to 200 ms natural conversation becomes very difficult.</p> <p>NOTE 2: High-quality video conferencing is an assumed service which uses (e.g.) MPEG to transport video to overcome the main objection to the quality of existing video-conferences.</p> <p>NOTE 3: For VoD and NVoD the upstream channel used for programme selection should be carried on a packet-mode (e.g. IP) bearer and "bandwidth" is an inappropriate term. Only infrequent, short messages are carried to select programme material.</p> <p>NOTE 4: VoD and NVoD services need relatively short one-way end-to-end delay if the user interaction is to be acceptable. The end-to-end delay variance for these applications must also be essentially zero but this may be achieved by application buffering.</p> <p>NOTE 5: IP datagrams should be transferred at the maximum possible burst rate the system is capable of. Services such as LAN interconnection which apparently do need the maximum possible rate in each direction are delay-insensitive, so that the full bandwidth is not needed in both directions simultaneously.</p> <p>NOTE 6: "Transfer Mode" refers to the switching paradigm of the complete network. "Circuit Oriented" is the classic PSTN/ISDN model of a deterministic isochronous switched circuit. "Connection Oriented" is the concept introduced in X.25 and continued in ATM for a packet-mode, possibly non-deterministic, information transfer based on the "virtual" call. "Connectionless" is the IP model where information is transferred in autonomous independently addressed packets and there is no concept of a "call".</p> <p>NOTE 7: Mean transit delay and transit delay variation are measured as in ITU-T Recommendation E.800 [18] between W.3 and W.2.</p> <p>NOTE 8: Whilst the main data flow for WWW browsing is in the "down" direction, a substantial upstream bandwidth is also required for TCP acknowledgements, estimated to be 10 % of the downstream requirement.</p> <p>NOTE 9: Most applications (for example POTS) which need a symmetrical "duplex" service are quite low bit-rate. Even the "hypothetical" high-quality videoconference service only needs a maximum of 6 Mbit/s in each direction.</p> | | | | | |

Based on this the following bandwidth specification may be derived for HIPERACCESS.

The HIPERACCESS standard shall support a peak aggregate information rate of at least 25 Mbit/s at the UNI of a single AT. This aggregate rate will be shared between the incoming and outgoing streams associated with all the active applications supported through the UNI.

Methods shall be defined for an APT to communicate with ATs which support lower peak information rates. This may for example be to allow lower cost implementation, or to operate with longer range.

The HIPERACCESS standard will specify methods to allow conformant equipment to manage (for example through radio channel numbering) a radio spectrum allocation of a minimum of 2 GHz.

The HIPERACCESS standard shall allow for implementation of systems providing efficient transport of ATM, IP, MPEG streams, POTS, and narrowband ISDN.

Multicast is an important capability to support future IP and ATM applications efficiently. Radio access systems in particular can be made more efficient by using multicast for data intended for multiple users.

HIPERACCESS must therefore support multicast.

5.2.4 Signalling

HIPERACCESS shall not terminate the UNI signalling. It shall only interpret the UNI signalling to the extent necessary to allow efficient multiple access.

In general billing is done through the switching function in the network and the HIPERACCESS system shall neither include any specific, nor imply any limitation on, billing functionality.

5.2.5 Performance

It shall be possible for a HIPERACCESS system to achieve the following objectives when deployed under limiting conditions (in respect of range, capacity, etc.).

Table 5.3: Performance objectives

| | POTS | ISDN | ATM | IP |
|--|-------------|-------------|--------------|--------------|
| Access network delay (mean) ms (notes 1 and 2) | 10 | 10 | 5 | 10 |
| Access network delay variation μ s | 12,5 | 12,5 | 1 000 | 100 000 |
| Bit error ratio | 10^{-3} | 10^{-6} | N/A | N/A |
| Cell/packet error ratio | N/A | N/A | $[10^{-10}]$ | $[10^{-10}]$ |
| Cell/packet loss ratio | N/A | N/A | $[10^{-8}]$ | $[10^{-8}]$ |
| Cell/packet mis-routing ratio (note 5) | N/A | N/A | $[10^{-12}]$ | $[10^{-12}]$ |
| Route set-up time (note 3) ms | 50 | 50 | 50 | N/A |
| Availability | note 4 | note 4 | note 4 | note 4 |
| NOTE 1: If the round trip delay exceeds a value which depends on the national network echo cancellers may be needed. If the access network delay exceeds certain values special steps may need to be taken with ISDN to ensure that certain layer 3 timers operate correctly. | | | | |
| NOTE 2: For ATM the delay and delay variation is for constant bit-rate services. | | | | |
| NOTE 3: Route set-up time is the time from submitting an DLC_CONN_req to the Data Link Control (DLC) layer to the DLC layer returning a positive DLC_CONN_conf, or the equivalent, assuming that the service node response time is zero. | | | | |
| NOTE 4: Availability objectives are tbd. Sources of information for guidance can be found in ITU-T Recommendations. G.827 [23], I.355 [25] and I.357 [26], ETSI standards I-ETS 300 416 [11] and I-ETS 300 465 [12], and ITU-R Recommendations. F.557 [15], F.695 [19], F.696 [20] and F.697 [21]. | | | | |
| NOTE 5: Cell and packet mis-routing occurs when Virtual Channel Indicator (VCI)/Virtual Path Indicator (VPI) information or IP source/destination addresses become corrupted, the errors are not identified by the error control mechanisms, and the corrupted routing information is valid for the access system so that the information ends up with the wrong user. | | | | |

5.2.6 Radio specific security requirements

Because a radio access system may be subject to attempted interception of the "on-air" signals, a complete HIPERACCESS network may incorporate security systems designed to prevent fraud and protect the privacy of the customers', service providers' and operators' traffic. The following security features will be needed in the end to end network and the HIPERACCESS standard should be consistent with them:

- the network management system should be able to manage all aspects of system security;
- the security system should prevent unauthorized eavesdropping on customer communications and network management traffic;
- systems should support the applicable requirements for legal interception [40];
- the HIPERACCESS standards shall not prevent security features from being removed from a system or set at a level appropriate to meet the requirements of any export regulations;
- it shall be impossible to use a stolen or cloned network component in order to eavesdrop on network traffic or obtain service illegally from the network;
- the AT installation process shall include a check that a "legal" AT is being attached to the network; and
- it shall be possible for a security check to be performed periodically to check the validity of all ATs subscribed to the network.

The need for HIPERACCESS systems to include any specific security features is for further study.

5.3 Operational requirements

This subclause presents requirements on HIPERACCESS systems based on broadband operators' likely service objectives and an analysis of critical factors affecting radio access network commercial viability, including the following:

- subscriber-dependent factors such as population densities, principal applications required, user-traffic models and network penetration and growth;
- environmental factors such as prevailing weather conditions, constraints on geographical coverage etc.; and
- cost minimization/resource utilization factors such as installation and maintenance of equipment, frequency planning and management and bandwidth utilization.

This is not intended to be a rigorous market analysis; for example we only divide users into residential and small business segments. The aim is rather to extract basic operational requirements on HIPERACCESS systems, for example, on system range, capacity, and coverage, to allow candidate technologies to be selected for HIPERACCESS.

5.3.1 User density and market penetration

5.3.1.1 Residential market

We can assume that the household is the unit that buys residential services (in other words there is one *subscriber* at most per household, though there may be more than one *user* in the household). We can derive the residential user density from the household density of the targeted deployment areas, given the targeted service penetration.

Caution must be taken with figures for "average" household density, as local peaks may be much larger than the average for a large area. Table 5.4 gives figures for typical household densities in a square kilometre in Europe and the likely range of variations on a smaller scale.

Table 5.4: Typical household densities in Europe (Households per square km)

| Environment: | Rural | Suburban | Urban | City centre |
|---------------------------|----------|--------------|----------------|-----------------|
| Average household density | | 1 000 | 3 000 | |
| Household density range | 5 to 500 | 500 to 3 000 | 1 000 to 8 000 | 8 000 to 30 000 |

In rural areas HIPERACCESS may be rolled out by a single operator to provide full service to all customers, since the areas may not be attractive enough for competitive operators. Therefore HIPERACCESS should permit 100% penetration in these areas.

In suburban areas HIPERACCESS should be able to support at least 50% penetration of the market, and in urban areas at least 30%. In dense city centre areas HIPERACCESS need only to be able to support at least 10% penetration.

HIPERACCESS systems may be installed both in regions of relatively low household densities (rural areas) and regions with very high household densities (urban areas including city centres). At least in the early roll-out stages of a network, only a small fraction of the potential user base within the coverage area may subscribe, which will result in a low-to-medium user density in densely populated areas.

HIPERACCESS systems must therefore allow economic deployment in areas with fairly low user density, but have adequate growth potential to maintain a good grade of service as the user density increases. In rural areas HIPERACCESS systems should target clustered households, such as villages, and not isolated houses.

5.3.1.2 Business market

In a business a number of employees may use broadband services simultaneously through a single company subscription (probably sharing the access transceiver through an internal network). Little data seems to be available on the actual *density* of businesses. However data is available on the proportions of businesses across economies. Table 5.5 gives data for five EU countries.

From the table it is clear that in each market:

- approximately 2/3 to 3/4 of all telephone connections are to residences; and
- 99% of all businesses employ less than 250 employees.

Table 5.5: Market statistics for Europe

| Country | Households 000s | Res. lines 000s | Total lines 000s | Enterprises - % - with # of employees: | | | | Number of enterprises |
|---------|--------------------|-----------------------|---------------------|---|-------------|--------------|-------|-----------------------------|
| | | | | 1 to 9 | 10 to 49 | 50 to 249 | 250 + | |
| France | 22 540 | 20 737 | 32 900 | 83,00 | 14,00 | 2,50 | 0,50 | 821 900 |
| Germany | 35 250 | 32 136 | 42 000 | 80,60 | 16,40 | 2,30 | 0,70 | 1 430 300 |
| Italy | 19 700 | 17 694 | 24 542 | 93,70 | 5,60 | 0,60 | 0,10 | 2 913 200 |
| Spain | 12 000 | 11 262 | 15 413 | 84,50 | 13,60 | 1,60 | 0,30 | 724 300 |
| UK | 22 300 | 20 739 | 30 678 | 79,70 | 16,60 | 3,00 | 0,70 | 826 600 |

These figures show that the predominant potential market for access will be for residential and small business premises, with the majority of business premises (at least 97% in fact) housing less than 50 employees. It is assumed that all businesses will also have telecommunications service.

HIPERACCESS should be designed on the assumption that, in each type of region (rural, suburban, urban, city centre) it should support the same penetration of the SME customer base as the residential customer base. The density of SMEs is assumed to be in proportion to the household density as indicated by table 5.5. The number of users per subscription (i.e. per customer) will be distributed according to the distribution of enterprise size. However it is assumed that only half the employees in each enterprise will have access to broadband services (i.e. on average this is the proportion of employees who use communications in their daily work).

5.3.2 User reference traffic models

These traffic models are presented for the purposes of understanding the traffic mix and estimating spectrum requirement. They are thought to be reasonable projections or current trends but are not based on specific market research.

NOTE: A subscriber means one connected via a HIPERACCESS network. Only households which require broadband services such as VoD and internet access will subscribe to such networks.

5.3.2.1 Residential users

Each user may access a set of services through a HIPERACCESS system. A single household may have several people who may use the services simultaneously.

Voice Telephony: Most subscriber households will use voice telephony. The working assumption for residential traffic intensity is 70 mE in the busy hour at 64 kbit/s duplex.

ISDN: Most subscriber households will have ISDN access and these will also generate 70 mE in the busy hour at 128 kbit/s duplex (assuming that the D channel is interworked at layer 2 rather than layer 1).

Video conferencing: It is assumed that 10% of HIPERACCESS households will use video conferencing (or similar residential services) also at 70 mE in the busy hour at 384 kbit/s duplex.

Video on Demand: In UK the average household watches TV between 20 hours and 25 hours per week. Many households have more than one TV. At peak viewing time one third of the population is watching TV. It is assumed that 50% of subscriber households will use video on demand services. and of these on average each household will watch six hours of video per month. The downstream bit rates required for a VoD channel are between 1,5 Mbit/s and 6 Mbit/s depending on content - 3 Mbit/s average is assumed. Upstream traffic is assumed to be very low.

Near VoD and Pay Per View: No additional allowance has been made for these services on the assumption that they will substitute for VoD.

Internet Access: It is assumed that 80% of subscriber households will use internet access. From statistics gathered within a business environment an average internet user may download at an average rate of about 12 kbit/s in the busy hour, i.e. a total of about 5 Mbytes. This represents a low average utilization of a packet system at 25 Mbit/s. It is assumed that for future applications the utilization will be much higher: 1% in the busy hour. The upstream data would be smaller, typically "mouse-clicks", email and TCP acknowledgements, at 20% of the downstream rate.

LAN access and interconnect: Presumably this will only be used by "homeworkers" and the small office home office (SoHo) market. It is assumed that 10% of subscriber customers fall in this category and that they utilize LANs for only 0,25% of the busy hour but while accessing they use high data rates.

These figures are summarized in table 5.6.

Table 5.6: Traffic model summary - residential (busy - hour)

| Services | % HH | Utilization | Down (kbit/s) | Up (kbit/s) | Down tot (kbit/s) | Up tot (kbit/s) |
|----------|------|-------------|---------------|-------------|-------------------|-----------------|
| Voice | 80% | 7% | 64 | 64 | 0,4 | 0,4 |
| ISDN | 10% | 7% | 128 | 128 | 0,1 | 0,1 |
| V.conf | 10% | 7% | 384 | 384 | 0,3 | 0,3 |
| VoD | 50% | 3,3% | 3 000 | 0 | 50 | 0 |
| Internet | 80% | 1% | 25 000 | 5 000 | 200 | 40 |
| Rem. LAN | 10% | 0,25% | 25 000 | 25 000 | 6 | 6 |
| Total | | | | | 264 | 54 |

The "total" columns give an estimate of the mean upstream and downstream bandwidth per residential user (in kbit/s). These are the best estimates that could be made without formal market research. It is possible that traffic levels could be much higher in the longer term. The residential figures and business figures should not simply be added together as it is expected that busy hours do not correspond for the two categories. The data is intended to give guidance on the average values for channel bandwidth, not the maximum which a user may require.

5.3.2.2 Business users

In a small business the figures in the table 5.7 apply to the usage by each employee of the businesses of subclause 5.3.1.2 using telecommunications in their daily work.

Voice Telephony: It is assumed that every business user of a HIPERACCESS network will use voice telephony. The working assumption for business user traffic intensity is 100 mE of external traffic in the busy hour at 64 kbit/s duplex.

ISDN: It is assumed that 10% of business users of a HIPERACCESS network will have ISDN access and these will also generate 100 mE in the busy hour at 128 kbit/s duplex (assuming that the D channel is interworked at layer 2 rather than layer 1).

Video conferencing: It is assumed that 10% of business users of a HIPERACCESS network will use video conferencing also at 100 mE in the busy hour at 384 kbit/s duplex.

Video on Demand: VoD is not seen as an important application for business users.

Internet Access: It is assumed that 100% of businesses will have Internet access. The utilization per employee is assumed to be the same inbound as in the residential case, and outbound rates more equal, as a significant number of businesses will have web servers on their premises.

LAN access and interconnect: In the small business market, it is paradoxical that the proportion of remote LAN access will probably be about the same as the residential market. Businesses of the size which will be served by HIPERACCESS will not have too many remote workers since they are very small anyway.

These figures are summarized in table 5.7.

Table 5.7: Traffic model summary - business

| Service | % employees | Utilization | Down kbit/s | Up kbit/s | Down tot. kbit/s | Up tot. kbit/s |
|----------|-------------|-------------|-------------|-----------|------------------|----------------|
| Voice | 50% | 10% | 64 | 64 | 3 | 3 |
| ISDN | 5% | 10% | 128 | 128 | 1 | 1 |
| V.conf | 5% | 10% | 384 | 384 | 2 | 2 |
| VoD | 0% | 0% | 3 000 | 0 | 0 | 0 |
| Internet | 50% | 1% | 25 000 | 5 000 | 125 | 250 |
| Rem. LAN | 5% | 0,5% | 25 000 | 25 000 | 6 | 6 |
| Total | | | | | 1 260 | 262 |

| Service | % businesses | Utilization | Down kbit/s | Up kbit/s | Down tot. kbit/s | Up tot. kbit/s |
|-------------|--------------|-------------|-------------|-----------|------------------|----------------|
| Web serving | 25 | 80 | 5 000 | 25 000 | 1 000 | 5000 |

The "total" columns give an estimate of the mean upstream and downstream bandwidth per business user (in kbit/s). Again it should be emphasized that a number of users in a business may operate through one HIPERACCESS connection. The % employees column takes into account the factor of 50% of employees in each enterprise estimated to have access to broadband services. The separate summary for web serving uses percent of businesses with a web server, rather than percent of employees, since small and medium sized businesses tend to have one server, irrespective of the number of employees.

5.3.3 Installation issues

Environmental concerns mean that HIPERACCESS antennas on customer premises must be small. As a target, the maximum size of the AT or repeater antenna should not exceed 0,45 m in any dimension irrespective of frequency; and the system design should assume that a pointing tolerance of no better than $\pm 2^\circ$ may be achieved but desirable to be looser tolerance for ease of installation. System designs with electronically steerable antennas are interesting. Account should also be taken of the antenna deflection caused by wind.

Installation of customer premises equipment is not a negligible cost. The HIPERACCESS standards should allow a design to include any functionality necessary to enable the economical installation of subscriber equipment. For example, it should make available Received Signal Strength Indicator (RSSI)/Bit Error Ratio (BER) indications for optimum antenna alignment. Easy installation with a minimum of manual configuration should be the goal. Flexibility and an installation that is as automated as possible are highly desirable.

5.3.4 Capacity

In an initial low-density deployment a single HIPERACCESS APT may serve an area of radius 5 km with a low user density. In this situation it is desirable for the single APT to support a reasonable number of users without artificial limits being imposed by, for example, AT addressing. Therefore the HIPERACCESS standard must allow one APT to support a logical minimum of 2 000 AT.

One APT should be able to support a group of customers and ideally fully utilize at least one Synchronous Transmission Multiplex-1 (STM-1) connection to the core network (via the Access Point Controller (APC)) provided that this rate is feasible over a practical air interface. However it shall not be mandatory to connect through an STM-1 interface, and lower capacity interfaces are allowable where appropriate.

To optimize functions such as handover and provide enough AP capacity a single APC must be able to manage a minimum of eight APTs. This would mean that the APC connection to the SNI would fill the capacity of two STM4 links.

The HIPERACCESS system should support efficient frequency re-use and the protocol design should incorporate appropriate features to do this. Some fixed access systems today claim a re-use factor of one in a cellular deployment and HIPERACCESS should be at least as good. HIPERACCESS should be designed for maximum spectral efficiency, taking into account the trade-off between modulation efficiency and good frequency re-use.

HIPERACCESS should support features to maximize the scalability of an installed system (i.e. the growth from coverage-limited to capacity-limited).

The statistical multiplexing efficiency of the multiple-access scheme should be as high as possible. Features should be incorporated to allow system control parameters to be optimized for the traffic mix being encountered on individual APTs. For example, on a given site one sector may cover residential premises with a high usage of video on demand while another sector covers largely business premises with mainly LAN interconnection.

5.3.5 Radio range and coverage

At frequencies above 10 GHz, heavy rain or snow may cause strong attenuation and unavailability events. Additional attenuation will be caused by atmospheric absorption by oxygen, hydroxyl ions, and fog. Additional margin should be allowed in the link budget in order to protect radio links from these events. A range requirement is stated here for the purposes of providing a reference point for link budget and should not be taken to prescribe the implementation.

The HIPERACCESS PHY layer specification shall allow enough system gain to achieve a range of at least 5 km at 99,99% availability in LOS propagation conditions at the relevant frequency in ITU-R Recommendation PS 837-1 [17] climate zone E, with directional antennas meeting the requirements of subclause 5.3.3 above at the subscribers' premises and four sectored antennas at the base site. For the purposes of this specification availability is as defined in ITU-T Recommendation G.821 [22] (or its ITU-R Recommendation equivalent: ITU-R Recommendation F.697-2 for ISDN [16]).

Network operators deploying HIPERACCESS in other environments should note that more or less planning margin may be needed to obtain the required availability.

It should be possible to trade-off service bandwidth against range when deploying a HIPERACCESS system.

At the microwave frequencies at which HIPERLAN will be deployed a line of sight is needed between network nodes. This is difficult to obtain in all circumstances especially in urban areas and a standardized repeater function is needed to optimize coverage at low cost.

A HIPERACCESS system must be technically able, by using coverage overlap, repeaters or other techniques, to reach at least 95% of potential users in a coverage area, taking account of atmospheric attenuation. Table 5.8 shows the coverage improvement possible through the use of coverage overlap based on analysis of one area in the USA.

Table 5.8: Coverage achieved as a function of coverage area overlap

| Situation | Probability of LOS Coverage |
|--|-----------------------------|
| No Overlap between coverage areas | 0,50 to 0,60 |
| Single Overlap | 0,75 to 0,84 |
| Double Overlap | 0,875 to 0,936 |
| NOTE: Assumptions are: coverage area radius = 5 km; APTs and ATs placed on building tops; probability of LOS = 0,60 for range < 2 km, 0,50 for range > 2 km. | |

HIPERACCESS should incorporate features to cope with and exploit overlapping coverage.

5.3.6 LOS deployment; Channel models

At low microwave frequencies, for example up to 4 GHz, there may be enough signal diffraction around obstacles to allow a significant number of customer locations to be served even though they do not have a LOS to the APT. At higher frequencies LOS is generally needed, but at short ranges an AT may still be able to operate even though the LOS is obstructed by quasi-opaque objects such as trees.

In either case, if the LOS path is obstructed the relative amplitude of reflected paths will increase, and the system shall cope with multipath-induced effects including amplitude fading, intersymbol interference and "click" phenomena. Suitable channel models should be used in the design of the HIPERACCESS radio system.

5.3.7 Maintaining QoS

The QoS objectives for fixed services are generally very stringent (for example availability of 99,99 %). A number of problems may arise during the operation of a network which effect the quality of the service delivered to an AT.

- Load balancing between APTs may be needed.
- The radio path between HIPERACCESS nodes may become obstructed, either temporarily or permanently.
- Sporadic co-channel interference may arise from within the system or from another system.
- Network equipment may fail.
- As the network grows new APTs may be built to increase capacity or extend or "fill-in" coverage.

HIPERACCESS shall incorporate system features to maintain the QoS in the face of these effects. Possible features include changing the connectivity of the radio segment ("handover") and dynamic channel allocation. These features may need to be applied on a short (e.g. within a call); medium (e.g. between calls); or long (e.g. from season to season) term basis.

5.3.8 Frequency planning and management

Whilst coverage and capacity planning are expected to be essential for an operator to be able to manage QoS, frequency planning may not be essential if the system design can incorporate some features to self-manage frequencies (known generically as Dynamic Channel Assignment (DCA)). Also, the effectiveness of such features may depend on the type of service and the QoS targets of the operator.

The range of possibilities for frequency planning in a HIPERACCESS system can be illustrated by the following simple scenarios. Operator A may provide broad-band services, in the form of permanent virtual circuits, to SMEs only and therefore does not require DCA; indeed DCA may not optimize the service quality for this type of link. Therefore operator A prefers to undertake such planning in a manner completely under his control. Operator B, however, provides a complex mix of broad-band services to mainly residential customers and therefore welcomes automatic DCA facilities.

HIPERACCESS shall incorporate DCA but should also permit external optimization of frequency usage as appropriate.

5.3.9 General economic requirements

To optimize the economics of deploying a HIPERACCESS system the following requirements should be considered:

- the cost of base station equipment should obviously be as low as possible; but in particular the cost of customer radio terminations should be minimized since a high proportion of mature system cost is likely to lie in these;
- the AT should ideally be customer installable;
- the system should, as far as possible, allow for graceful upgrade of capacity as customer numbers grow, without manual adjustment of the AT;
- the system should incorporate features to minimize the need for any maintenance visits to the customer premises.

5.3.10 Environmental conditions

HIPERACCESS networks are primarily intended to operate outdoors. The equipment must meet ETS 300 019 [7] class 4.1, and may have to meet other regional standards. Examples of the operating conditions include salt spray, humidity, temperature and wind loading.

5.3.11 ElectroMagnetic Compatibility (EMC)

HIPERACCESS systems will conform to all applicable EMC standards.

5.3.12 Standardization requirements

The HIPERACCESS standard shall include PHY and DLC layer specifications, and interworking functions to the UNIs and SNIs to be supported. Not all manufacturers may wish to manufacture interoperable equipment; and operators may not wish to procure interoperable equipment from different manufacturers.

The PHY layer specification should therefore be produced in two parts. The "coexistence" specification will define, as a minimum, the spectrum mask, transmit power, receive sensitivity, and spurious emissions and responses. It may also include other aspects such as frequency sharing etiquette. The other part will include all other aspects of the PHY layer.

5.4 Spectrum and regulatory issues

5.4.1 Spectrum requirements

The potential market for HIPERACCESS equipment is very large - a significant proportion of households and small business premises in most countries. To achieve this market potential the production volumes must be very high, which can best be achieved by deployment of similar equipment operating at the same frequency in every country. It is therefore desirable that HIPERACCESS systems should be allocated at least one international dedicated band, sufficiently large and at an appropriate frequency, for mass deployment.

However, it may take some time to obtain such a band, and therefore HIPERACCESS systems should be able to operate in other suitable fixed service bands. The coexistence part of the PHY layer specification should take this into account.

Very high microwave frequencies are prone to severe atmospheric attenuation and the necessary device technology is also immature. The choice of frequency band should enable operators to meet availability, QoS and GoS requirements economically.

5.4.2 Operation in licence exempt bands

The HIPERACCESS standard, though intended primarily for use in licensed bands, may also be applied in licence-exempt bands which are shared with other services on an ad-hoc basis, provided that HIPERACCESS conforms to the sharing etiquettes for these bands.

However, HIPERACCESS systems will not be deployed in the 5,15 GHz to 5,25 GHz band, in which HIPERLAN systems operate.

5.4.3 Co-ordination

Whilst HIPERACCESS systems provide fixed access they have some operating and commercial characteristics in common with cellular mobile systems:

- mass market;
- high volume;
- premium on capacity;
- possibly rapid expansion of capacity to meet market demand.

For these reasons the operator of a HIPERACCESS network will need the ability to deploy very rapidly, to vary capacity, and change the frequency plan (as far as applicable). Therefore it is important that a similar radio regulatory regime to mobile services is used - there should not be a need to involve the local administration in site co-ordination. This differs from common practice with fixed links.

6 Architecture

6.1 Reference models

There are two specific reference models applicable to HIPERACCESS members of the BRAN family: the General Reference Model (GRM) and the General Protocol Model (GPM).

NOTE: Although the present document applies to HIPERACCESS systems, whatever core network they are connected to, it is intended that both of these reference models should align with the common reference model DTR/BRAN 040001 (see annex A) used to co-ordinate and align the work of the ATM Forum, and the ETSI BRAN Project, primarily addressing HIPERLAN systems. A common reference model may also be developed for IP systems.

6.1.1 GRM as applied to HIPERACCESS

Before we specify the GRM itself, (see subclause 6.1.2) , the model given here (figure 6.1) is of the GRM as might be applied to a general HIPERACCESS scenario. It is an example and does not constrain the actual implementation of any real system.

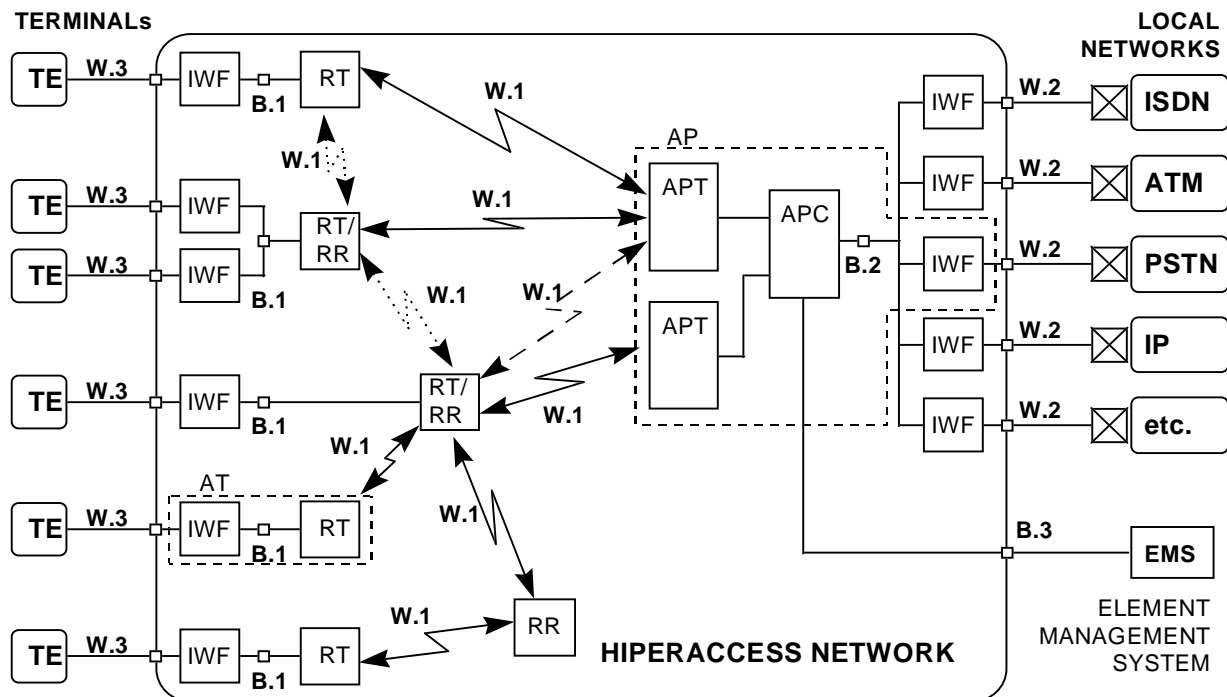

Figure 6.1: BRAN GRM as might be applied to HIPERACCESS

The HIPERACCESS network, depicted in the enclosed part of the figure, provides a means of communication between a terminal (or terminals), typically on customers premises, and a switch or router, typically operated by a telecommunications operator and connected to one or more core networks. The HIPERACCESS network is a network element from an Operation Administration and Management(OA&M) viewpoint and should provide appropriate communication via interface B.3, to an external EMS which will be part of the operator's umbrella network management system.

The telecommunications networks which may be accessed in this way include:

- PSTN;
- ATM networks;
- ISDN; and
- IP networks.

In practice, some of these networks may be carried in others (such as IP over ATM) and further types of network may also be supported by adaptation over one of these.

The BRAN comprises the following:

- **AP**, which are the interface points to core networks.
- **APC** which present network-specific interfaces to the core network via an InterWorking Functions (IWFs) which comply with a appropriate standards (e.g. V5 for PSTN, VB5 for ATM etc.). The APC also presents OA&M information from the entire radio access network to an external EMS. The APC may be physically distributed and the HIPERACCESS network may include more than one APC associated with a local network to provide a degree of fault tolerance and redundancy. The APC's principal function is to control the routing of traffic through the HIPERACCESS network, including optionally the provision of diverse routing between ATs and the core network to avoid congestion, faults, or (temporary) obstruction of LOS radio paths. Such alternative paths are indicated by broken lines in figure 6.1. The APC communicates with a number of APT via PP links (fibre, copper, microwave, etc.) which are not explicitly specified.
- **IWFs**, which translate the internal (B.2) interface of the HIPERACCESS network into network specific interfaces of the external core network and translate the internal (B.1) interface of the HIPERACCESS network into external interfaces with terminal equipment.

- **APT**, distributed so as to be able to provide coverage throughout the service area of the BRAN. These communicate via the air interfaces (W.1) with Radio Terminations (RTs) and Radio Relays (RRs) or units which combine the functions of both RT and RR.
- **ATs**. An AT comprises an RT and an IWF. It is normally located on or near customers premises, which communicate with the APT (possibly via one or more RR) and present fixed connections for customers' terminals. This connection (W.3) represents the network termination point: the demarcation between the operator's and the customers' responsibility. Multiple terminals may be connected to, and supported simultaneously by, one RT. The network may be designed so that each RT communicates via interface W.1 to a unique APT either directly or through a RR.
- **RTs** are the radio parts of the ATs.
- **RR** emulate one or more RTs as seen by the APT and emulate an APT as seen by a RT. The network may possibly allow RRs and if so may or may not allow cascading of RRs. RRs may support the direct connection of terminals - through interface W.3 - subject to the same considerations as for ATs. In this case they are denoted as RT/RR.

A HIPERACCESS network may possibly allow communication between RTs of different customers without passing via an external switch. Should routing within the HIPERACCESS network be allowed, it would not then be handled by the switch but instead by the radio resource control and association control systems (see figure 6.4). This would allow some spectrum saving since an internal call would otherwise potentially occupy twice the bandwidth.

However it represents a major change in access network functionality, conflicting with ITU-T Recommendation G.902 [24] and requires further study before such a feature could be supported. Radio paths implying routing within the HIPERACCESS network are shown dotted in figure 6.1.

6.1.2 HIPERACCESS GRM

The BRAN GRM for HIPERACCESS systems is shown in figure 6.2A.

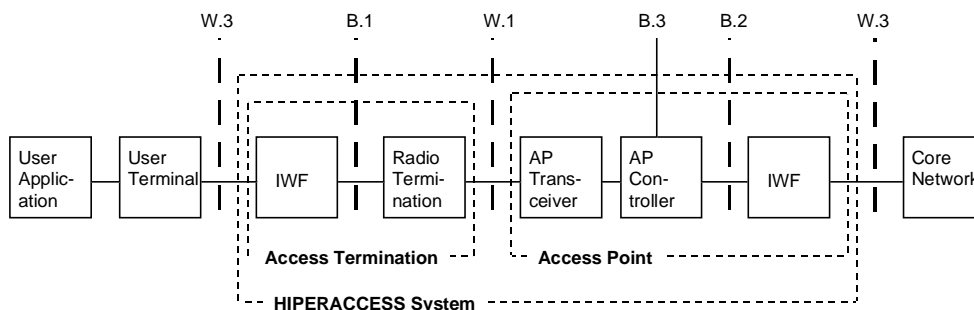

Figure 6.2A: BRAN GRM

Figure 6.2B indicates that the HIPERACCESS specification is intended to be applied to equipment using any of several different radio frequency bands, and that it is advantageous to ensure that the frequency-dependent parts of the radio access subsystem should be confined as far as possible to parts of the system "close" to the air interface, W.1.

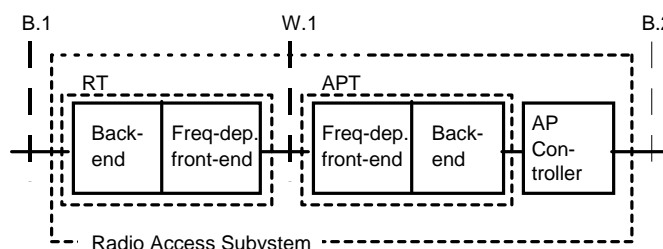

Figure 6.2B: Optional mult-band split within RT

An optional interface may be defined between W.1 (the air interface) and W.3 (the user-network interface) which physically splits an installation between outdoor and indoor units. The presence of this physical split is useful in some circumstances. However such an interface is not specified at present.

The model is intended to align with the ITU IMT2000 and ETSI UMTS models of the radio access network and identifies the following reference points:

Reference point B.1: a service interface which is defined in terms of abstract services and parameters for the user, control and management planes of the HIPERACCESS air interface protocol stack. This interface is expected to be a common definition for HIPERACCESS systems which define interoperation via a common air interface and HIPERLAN/2. It may not actually exist, and is therefore not required to be present in any real implementation, but forms the basis for specification and testing.

Reference point W.1: defines the radio interface between the APT and the radio termination. It is either a radio coexistence interface for all of the radio bands in which the HIPERACCESS network may operate or an interoperability interface that includes a radio coexistence interface and a standardized air interface.

A radio relay may be supported at this interface (figure 6.3).

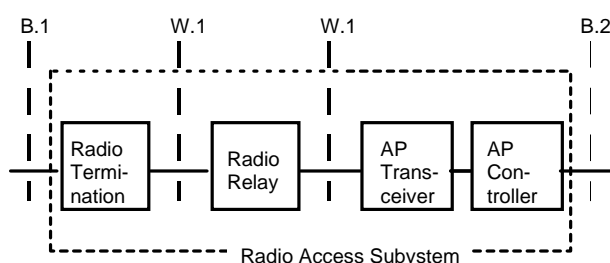

Figure 6.3 Radio relay at interface W.1

Reference point B.2: a service interface which is defined in terms of abstract services and parameters for the user, control and management planes of the HIPERACCESS air interface protocol stack. This interface is expected to be a common definition for HIPERACCESS systems which define interoperation via a common air interface and HIPERLAN/2. It may not actually exist, and is therefore not required to be present in any real implementation, but forms the basis for specification and testing.

NOTE: The AP may be considered to comprise one or more APTs connected to a single APC. The interface between these two elements is not necessarily visible and is not specified.

Reference points W.3 and W.2: the interfaces at W.3 and W.2 (W.2 on the network side and W.3 on the user side) are the supported standard interfaces to the relevant core networks and their related user interfaces. For any given core network, it is in principle possible to specify all of the relevant (W.3, W.2) pairs that BRAN systems support (see table 5.1). Non-standard W.3 and W.2 interfaces may be supported, but the BRAN family of interworking standards should not specify an interworking function for these cases.

Reference point B.3: an interface over which are specified the mechanisms for communicating with the EMS, specific to the management of the radio access network.

The BRAN protocol standards describe the mechanisms of the service interface at the B.1/B.2 reference point and the air interface at the W.1 reference point. Specifications of all other interfaces are outside the scope of the BRAN project.

6.1.3 GPM

The GPM for all HIPERACCESS systems is shown figure 6.4.

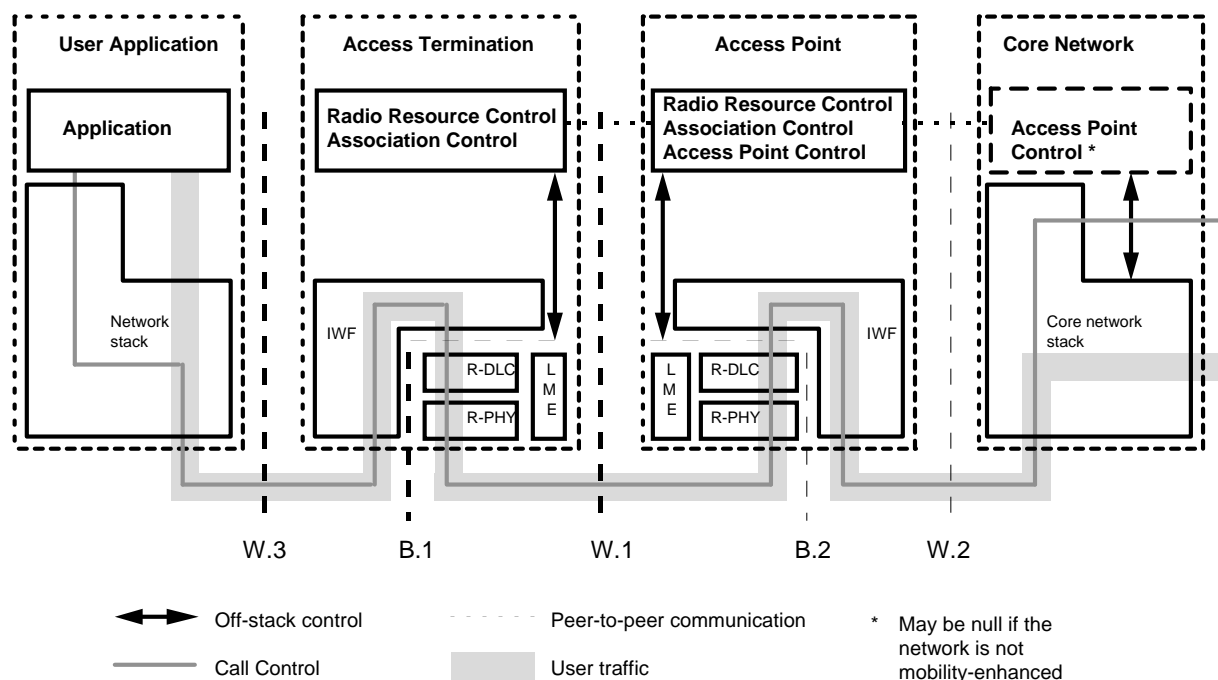

Figure 6.4: HIPERACCESS GPM

The dark lines indicate call control flows, the dashed lines special protocols between the system elements, the grey band indicates user data flow. The thin arrowed black lines show the "off stack" control interfaces.

The radio DLC layer contains two sublayers: a MAC sublayer and a Logical Link Control (LLC) sublayer.

The MAC sublayer implements a service policy that takes into account such factors as channel quality, number of terminal devices and medium sharing with other access sub-networks.

The LLC sublayer maintains the QoS on a virtual circuit basis. Depending on the type of service provided and channel quality, capacity and utilization, the LLC layer will implement a variety of means including Forward Error Correction (FEC), Automatic Repeat reQuest (ARQ) and flow pacing to optimize the service provided to the DLC user.

NOTE 1: Within the ATM community, generic flow control is being discussed - this may impact the functionality of the DLC layer and its service definition.

NOTE 2: Usage parameter control is an optional capability of ATM systems that may have impact on the specification of the radio DLC layer and on the AP behaviour.

NOTE 3: The wireless DLC and PHY layers are intended to be generic enough to support the services of at least those networks listed in table 5.1 by providing appropriate connection types and service qualities.

NOTE 4: The figure above (and figures 6.6 and 6.7) show an "Access Point Control" function in the core network. This may be provided in certain future core networks (e.g. UMTS) or may not be. When HIPERACCESS is behaving as a G.902 compliant network, the core network will not provide any radio resource management.

Radio relay support is shown in figure 6.5.

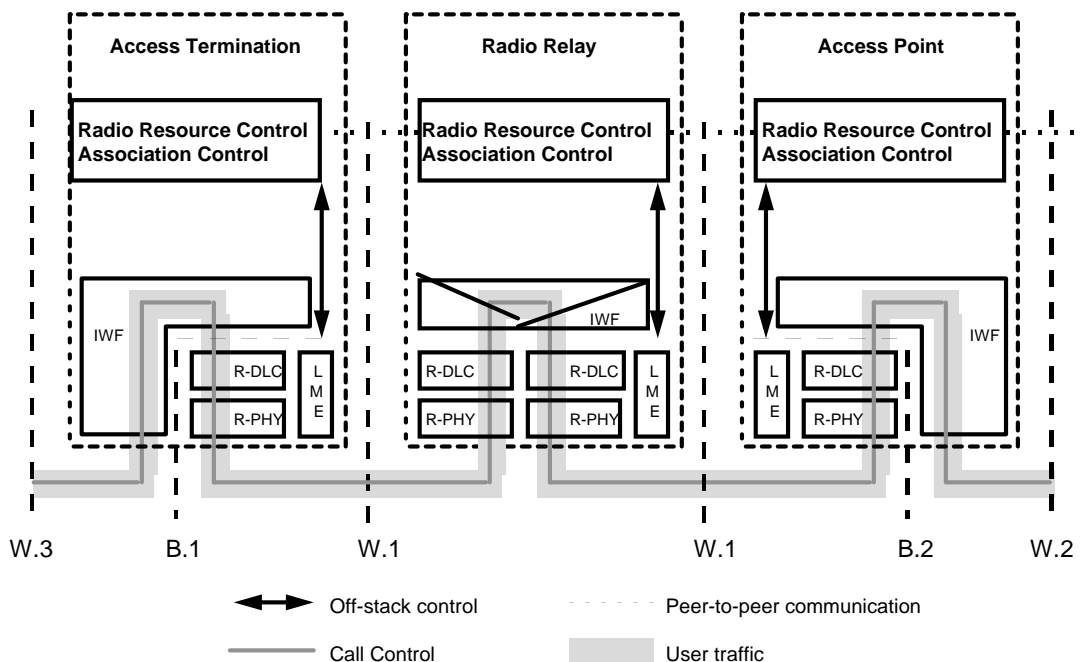

Figure 6.5: RR support

NOTE: Figure 6.5 illustrates a RR **router**. Other types of RR are possible. A **bridge** differs only in that the call control and user traffic are connected between radio DLC blocks. A **repeater** differs only in that the call control and user traffic are connected between R-PHY blocks. An **RR/RT** configuration is also possible.

6.1.3.1 The GPM in an ATM environment

Applying the GPM in an ATM environment would result in figure 6.6.

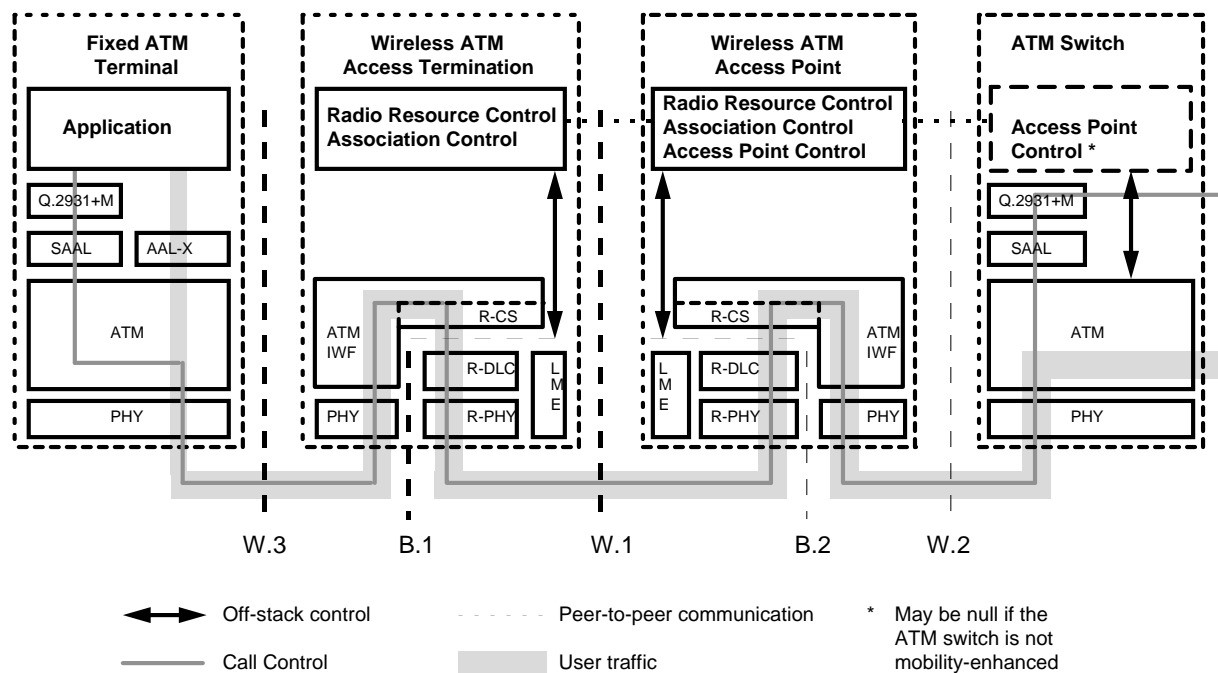

Figure 6.6: HIPERACCESS GPM in an ATM environment

This model is equivalent to models used by the wireless group of the ATMF.

Comparing this model to one of a wired ATM connection, the architecture presented above replaces the ATM PHY and part of the ATM layer with the two wireless layers that describe the wireless protocols: the radio DLC layer and the radio PHY layer. The radio DLC layer conserves the QoS of the each VPI/VCI "connection". In order to do this, it needs to know the VPI/VCI and other ATM cell header information.

The ATM PHY does not need this information and therefore the standard ATM PHY SAP definition can not be used in this architecture to communicate with the radio DLC. On the other hand, the standard ATM PHY SAP must be included in the architecture to assure compatibility with existing systems. This modelling conundrum is solved by requiring the ATM interworking function to store this information on connection set-up and re-insert it at the radio DLC SAP (B.1 and B.2).

The layer management entity of the radio DLC layer is used to convey QoS contract information and performance requirements between the radio DLC layer and the higher, connection control functions.

6.1.3.2 The GPM in an IP environment

Applying the GPM in an IP environment would result in figure 6.7.

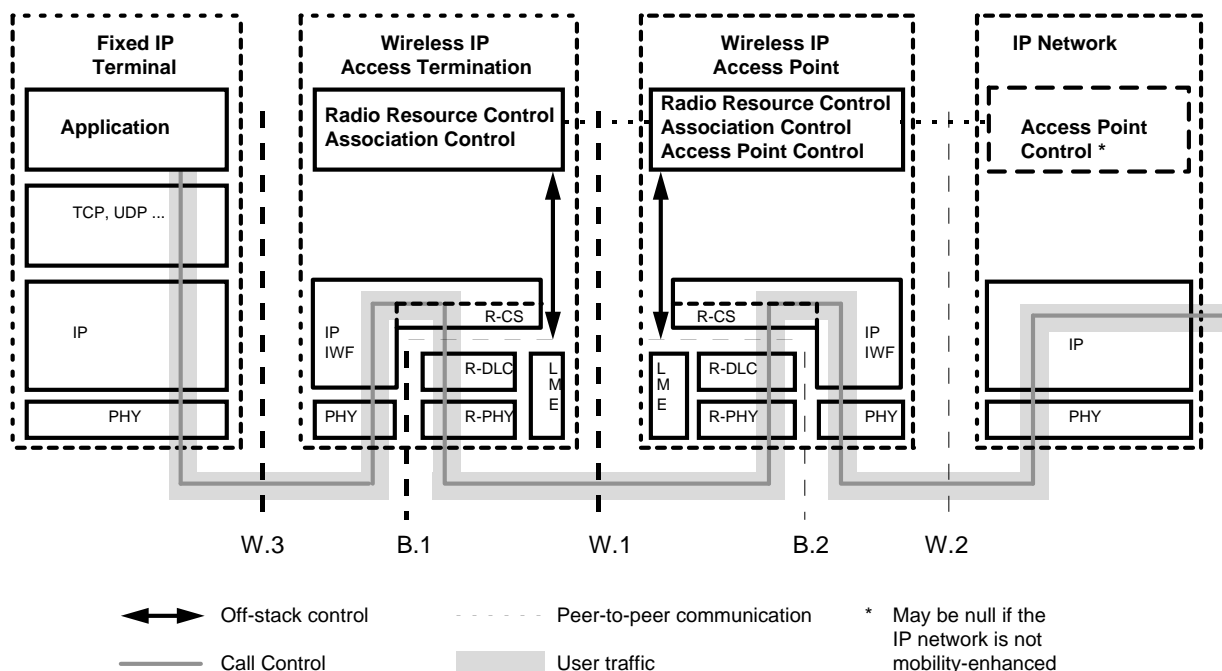

Figure 6.7: HIPERACCESS GPM in an IP environment

At the DLC SAP, one of the supported Service Data Units (SDUs) may be for an ATM cell, since IP packets will almost certainly need to be fragmented to a manageable size for the air interface. Support for alternative SDUs is not specified here, but may possibly also be included within the HIPERACCESS specifications. The support of a connectionless protocol such as IP over a DLC/PHY stack that also supports connection-oriented transport such as ATM creates several options on how this is to be done. The resolution of this issue is also left to the HIPERACCESS specifications.

NOTE: The radio DLC shall support bandwidth reservation protocols in an IP environment (e.g. RSVP).

6.2 Interoperation

The HIPERACCESS family may contain members that support full interoperation at the air interface and those that do not. It is not a property of the HIPERACCESS family but of individual types of HIPERACCESS.

6.2.1 General

Interoperation means the ability of any access termination built according to the standards to interoperate with any AP designed independently to the same standards, and provide defined services according to an "interoperation profile" specification. The interoperation profile defines the specific services and may possibly define the specific W.3 and W.2 interfaces essential to ensure interoperation. Not all permutations of W.2, W.3 and services will be standardized, or even be practical. Not all possible permutations of W.2 and W.3 will be provided on any specific HIPERACCESS equipment.

6.2.2 Coexistence

If air interface interoperation is not supported, the only specification for that HIPERACCESS family member is the coexistence air interface specification. There is no need to specify any network interface support if the HIPERACCESS system only has to coexist at the radio interface with other HIPERACCESS systems of the same type.

6.2.3 Air interface interoperation

When air interface interoperation is supported, then interface W.1 shall be fully specified. Support for interoperation of specified network interfaces (W.3 and W.2) may also be specified. Some services may be defined to work over all W.3 and B3 interfaces (e.g. POTS service should work with interoperating equipment however the AP controller and its IWF are connected to a core network).

Support for air interface interoperation also implies that the service interfaces B.1 and B.2 are specified. B.1 and B.2 are specified at a logical level only, and specific implementations are a private matter for the manufacturer of the HIPERACCESS radio access system. This means that no interoperation is possible at the B.1 or B.2 interfaces. The manufacturer of a RT must therefore be entirely responsible for the interworking unit that connects any accessible, specified customer interface W.3 to the logical interface B.1. A similar case applies in the case of the IWF between B.2 and W.2.

The specifications for B.1 and B.2 must be flexible to account for future developments in network architecture and interfacing.

6.2.4 Network and user interfaces

If a network or interface is listed in table 5.1, then an interworking function will be defined and a procurement specification may call for interworking at this interface. Table 5.1 does not constrain the implementation of HIPERACCESS systems, a manufacturer may choose to supply other interfaces (proprietary or standard) either for legacy interconnect or to support future developments. In this case the necessary standards will not exist to ensure interworking.

NOTE: It is possible (and entirely permissible) that the W.3 interface could completely disappear in cases of access networks that communicate with, for example, integrated mobile terminals that contain a radio termination and a user application. The standard will not forbid such applications. This applies to the W.2 interface as well. In this case, the protocol models specified later may be collapsed to provide a single integrated protocol stack without a physically-accessible W.3 interface.

The interfaces at W.2 and W.3 are themselves not explicitly specified by HIPERACCESS - they are the responsibility of other standardization bodies.

Although the details of the HIPERACCESS W.2 and W.3 interfaces are not specified by the BRAN project, some new features of the interfaces and of the systems to which they connect may be required. For example, the AP Control function, if present in an ATM switch, may have to communicate with its counterpart in a HIPERACCESS system's AP, in order to support certain forms of mobility. It is up to the BRAN project to identify what additions are needed to support radio access, but the BRAN project must then persuade the appropriate body to create this support within its own specifications. The method by which this is done is to create agreed common reference models (e.g. the ATMF common reference model DTR/BRAN 040001 (see annex A).

Bibliography

DTR/BRAN-040001: "Broadband Radio Access Networks (BRAN); Common ETSI - ATM Forum Reference Model for Wireless ATM Access systems".

History

| Document history | | |
|-------------------------|----------|-------------|
| V1.1.1 | May 1998 | Publication |
| | | |
| | | |
| | | |
| | | |