

**Fixed Radio Systems;
Multipoint-to-Multipoint systems;
Requirements for broadband multipoint-to-multipoint
radio systems operating in the 24,25 GHz to 29,5 GHz band
and in the available bands within the 31,0 GHz
to 33,4 GHz frequency range**



Reference

DTR/TM-04120

Keywords

digital, DRRS, multipoint, MWS

ETSI

650 Route des Lucioles
F-06921 Sophia Antipolis Cedex - FRANCE

Tel.: +33 4 92 94 42 00 Fax: +33 4 93 65 47 16

Siret N° 348 623 562 00017 - NAF 742 C
Association à but non lucratif enregistrée à la
Sous-Préfecture de Grasse (06) N° 7803/88

Important notice

Individual copies of the present document can be downloaded from:

<http://www.etsi.org>

The present document may be made available in more than one electronic version or in print. In any case of existing or perceived difference in contents between such versions, the reference version is the Portable Document Format (PDF). In case of dispute, the reference shall be the printing on ETSI printers of the PDF version kept on a specific network drive within ETSI Secretariat.

Users of the present document should be aware that the document may be subject to revision or change of status.

Information on the current status of this and other ETSI documents is available at

<http://portal.etsi.org/tb/status/status.asp>

If you find errors in the present document, send your comment to:

editor@etsi.fr

Copyright Notification

No part may be reproduced except as authorized by written permission.
The copyright and the foregoing restriction extend to reproduction in all media.

© European Telecommunications Standards Institute 2002.
All rights reserved.

Contents

Intellectual Property Rights	5
Foreword.....	5
1 Scope	6
2 References	6
3 Symbols and abbreviations.....	7
3.1 Symbols.....	7
3.2 Abbreviations	7
4 General characteristics	7
4.1 MP-MP general system architecture	8
4.1.1 Startup phase.....	9
4.1.2 Low density of subscribers	9
4.1.3 High density of subscribers.....	9
4.2 Reference diagram.....	9
5 Deployment issues.....	10
5.1 Use as an access system	10
5.2 Coverage.....	11
5.3 Spectrum Efficiency	11
5.4 Backhaul links	12
5.5 Use of TDD or FDD.....	12
5.6 QoS issues	12
5.7 System capacity.....	13
5.8 Applicability of existing TM4 specifications	13
6 Co-ordination aspects.....	13
6.1 Co-existence between MP-MP and P-MP systems	13
Annex A: Requirements for MP-MP systems operating in the 26 GHz and 28 GHz frequency bands	14
Annex B: Requirements for MP-MP systems operating in the 31 GHz and 32 GHz frequency band ...	15
Annex C: Co-existence simulations for P-MP and MP-MP networks.....	16
C.1 Introduction	16
C.2 Methodology	16
C.2.1 System modelling.....	17
C.2.2 Rain fading	18
C.2.3 MP-MP system characteristics	18
C.2.4 Propagation.....	18
C.2.5 Antenna beam profiles.....	19
C.2.6 Geometry.....	19
C.2.7 Interfering power calculation	19
C.3 Adjacent area, co-channel case	20
C.3.1 Mesh to P-MP BS results - dry weather	20
C.3.2 Effects of rain	20
C.3.3 Mesh to P-MP TS interference	21
C.3.4 Conclusions for the co-channel case	22
C.4 Same area adjacent/near adjacent channel case.....	22
C.4.1 The interference model.....	22
C.4.2 Results for mesh to P-MP BS - adjacent channel	23
C.4.3 Effect of Guard Bands	24
C.4.4 Results for Mesh to P-MP TS.....	25

C.4.5	Effect of guard bands	26
C.4.6	Conclusions for systems in overlapping areas.....	26
Annex D: Bibliography	27
History	28

Intellectual Property Rights

IPRs essential or potentially essential to the present document may have been declared to ETSI. The information pertaining to these essential IPRs, if any, is publicly available for **ETSI members and non-members**, and can be found in ETSI SR 000 314: "*Intellectual Property Rights (IPRs); Essential, or potentially Essential, IPRs notified to ETSI in respect of ETSI standards*", which is available from the ETSI Secretariat. Latest updates are available on the ETSI Web server (<http://webapp.etsi.org/IPR/home.asp>).

Pursuant to the ETSI IPR Policy, no investigation, including IPR searches, has been carried out by ETSI. No guarantee can be given as to the existence of other IPRs not referenced in ETSI SR 000 314 (or the updates on the ETSI Web server) which are, or may be, or may become, essential to the present document.

Foreword

This Technical Report (TR) has been produced by ETSI Technical Committee Transmission and Multiplexing (TM).

1 Scope

The present document provides the results of studies into deployment of Multipoint-to-Multipoint systems. A range of issues has been considered, including co-existence with Point-to-Multipoint systems, capacity, spectral efficiency and coverage. Draft requirements for systems operating in various frequency bands have been considered and are referred to in the appendices.

2 References

For the purposes of this Technical Report (TR), the following references apply:

- [1] RAL CRABS Report D3P1B: "Line-of-sight propagation probabilities calculated from Rayleigh roof height distribution".
- [2] ITU-R Recommendation P.676-3: "Atmospheric attenuation".
- [3] ITU-R Recommendation P.840-2: "Rain attenuation".
- [4] ETSI EN 301 215-2: "Fixed Radio Systems; Point to Multipoint Antennas; Antennas for point-to-multipoint fixed radio systems in the 11 GHz to 60 GHz band; Part 2: 24 GHz to 30 GHz".
- [5] ETSI EN 301 213-1: "Fixed Radio Systems; Point-to-multipoint equipment; Point-to-multipoint digital radio systems in frequency bands in the range 24,25 GHz to 29,5 GHz using different access methods; Part 1: Basic parameters".
- [6] ETSI EN 301 213-3: "Fixed Radio Systems; Point-to-multipoint equipment; Point-to-multipoint digital radio systems in frequency bands in the range 24,25 GHz to 29,5 GHz using different access methods; Part 3: Time Division Multiple Access (TDMA) methods".
- [7] BFWAtg(00)03: "Co-ordination between Broadband Fixed Wireless Access systems in the 28 and 42 GHz frequency bands".
- [8] ETSI TR 101 853: "Fixed Radio Systems; Point-to-point and point-to-multipoint equipment; Rules for the co-existence of point-to-point and point-to-multipoint systems using different access methods in the same frequency band".
- [9] IEEE 802.16.2: "Local and Metropolitan Area Networks - Recommended Practices for co-existence of Fixed Broadband Wireless Access Systems".
- [10] Doc. SE19int3(00)10: "Co-existence Simulations for P-MP and MP-MP Networks".
- [11] CEPT/REC T/R 13-02: "Preferred channel arrangements for fixed services in the range 22.0-29.5 GHz".

3 Symbols and abbreviations

3.1 Symbols

For the purposes of the present document, the following symbols apply:

dB	decibel
dBm	decibel relative to 1mW
GHz	Giga Hertz
kbit/s	kilobit per second
ms	millisecond
ns	nanosecond
Mbit/s	Megabit per second
MHz	Mega Hertz

3.2 Abbreviations

For the purposes of the present document, the following abbreviations apply:

BS	Base Station
BWA	Broadband Wireless Access
CCS	Central Control Station
CEPT	European Conference of Postal and Telecommunications Administrations
CRS	Central Radio Station
CS	Central Station
FDD	Frequency Division Duplex
FWA	Fixed Wireless Access
LAN	Local Area Network
MP	MultiPoint
MP-MP	MultiPoint-to-MultiPoint
MWS	Multimedia Wireless System
P-MP	Point-to-MultiPoint
P-P	Point-to-Point (radio link)
RPE	Radiation Pattern Envelope
RS	Repeater Station
Rx	Receiver
TDD	Time Division Duplex
TDMA	Time Division Multiple Access
TE	Terminal Equipment
TS	Terminal Station

4 General characteristics

Broadband Wireless Access (BWA) systems have mostly used a P-MP architecture. Most ETSI standards for such systems assume a P-MP architecture. Developments have now made feasible alternative system architectures, in particular systems described as MP-MP, otherwise known as "Mesh" systems.

In P-MP systems, core network traffic is routed by one or more Base Stations (BS) to the end user stations. Each BS serves a number of end users, using one or more radio channels, with appropriate radio access techniques. In order to reach customers not in direct line of sight from a base station, repeater stations may be employed. Traffic is usually bi-directional. Both FDD and TDD channel arrangements are deployed. Several studies into co-existence between systems of both types have established guidelines for geographical and frequency spacing, needed to give satisfactory performance.

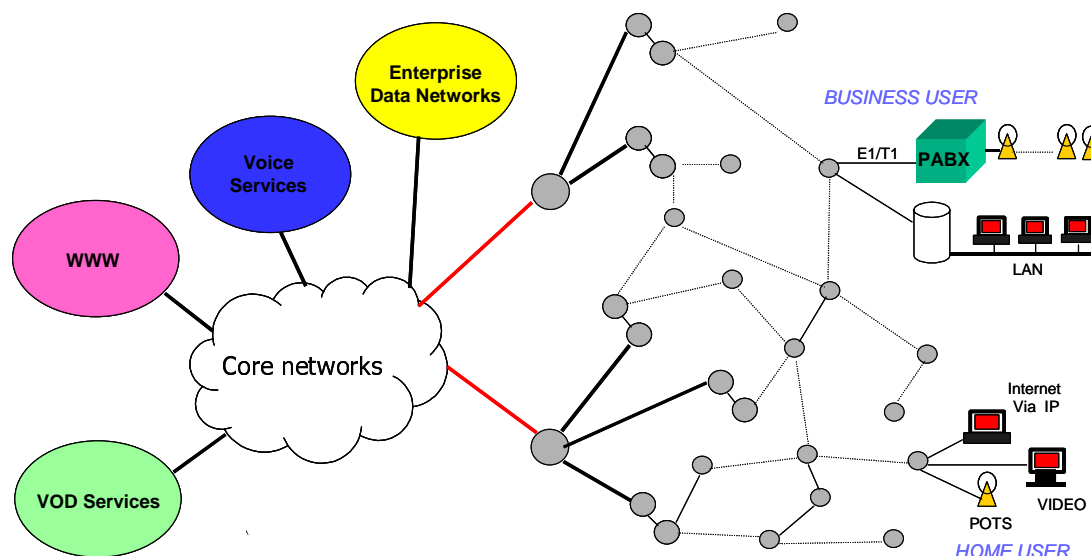

Figure 1: MP-MP system layout

MP-MP systems do not have base stations. Instead, all stations (often referred to as nodes) act as repeaters, with local access for traffic. Most (possibly all) nodes can be located on customer premises. The remainder (if any) are associated with connecting the mesh to convenient core network access points.

Traffic is routed via one or more radio repeaters to the required destination. In figure 1 there are a number of repeater stations, each connected to other repeaters and also terminal stations, which (for the time being) have connection only to one other station. As the network grows, these terminal stations can be converted to repeaters which relay information to new network subscribers.

A number of deployment issues are relevant to MP-MP systems. These are discussed in the following clauses of the present document.

4.1 MP-MP general system architecture

This clause describes how a typical MP-MP system can evolve from start-up through to high density deployment. It is possible to build a system with either directional or wide beam (even omni-directional) antennas but most advantage is obtained when narrow beam antennas are used throughout a system.

With omni-directional antennas, there is no need to re-point antennas as the systems evolves, but the interference created significantly limits the spectral efficiency of the system. At least one system of this type is in operation.

When narrow-beam antennas are used, it is necessary to point them accurately and to be able to re-point in new directions as the network evolves to accommodate more subscribers. It is not practical to do this manually, so a remotely controlled pointing mechanism of some kind is required. There are three main ways to achieve this:

- by switching between a series of fixed antennas;
- by electro-mechanical steering of directional antennas;
- by electronically steered arrays.

A suitable choice of antenna radiation pattern and gain combined with relatively short link lengths allows the interference to be localized. Apart from the reduction in normal transmitter power, less margin (or less ATPC range) is required to overcome rain fading. Frequencies can then be re-used many times within a network, leading to significant gains in spectral efficiency. Since there are usually several choices for the structure of a mesh joining a given set of user stations, the actual link directions can be chosen to maximize re-use and thus further improve spectrum efficiency.

4.1.1 Startup phase

Initially, there are no subscribers and there is no coverage. At least one point of connection has to be chosen to a core network and the first subscribers are then connected. A typical way to start is to deploy a small number of strategically sited "seed" node stations, which have line of sight to the first subscribers and to the point(s) of connection with core networks. These might or might not correspond with subscriber locations. It is not necessary to have wide area coverage from these initial sites. Coverage is only needed to the first subscribers requiring service. The number of stations required is very small and they can usually be replaced later by stations which correspond with actual subscribers. The number of "seed" node stations required can be estimated from figure 3.

4.1.2 Low density of subscribers

Once the initial startup phase has begun, it is not essential to deploy more "seed" node stations. Subsequent stations are either subscriber stations or points of connection to core networks. At low densities, the probability of interference between co-channel links is very low and much use can be made of time-domain techniques to avoid collisions between transmissions. The total amount of traffic that can be delivered to each subscriber depends in this phase mostly on the capacity of the links and is not limited by interference considerations.

4.1.3 High density of subscribers

As the system grows to accommodate more and more subscribers, the inter-node connections are adjusted accordingly. The mean link length decreases and the probability of co-channel interference slowly rises until a point is reached where an additional channel is needed to meet the total network capacity requirements. The addition of a radio channel again takes the system into a state where total traffic is not, in general, interference limited. Even when the number of available channels is small, a high subscriber density can be supported. The network can continue to expand and adapt until the available spectrum limits the network capacity. Further expansion is possible but at the expense of the mean bit-rate supplied to the subscribers. Figure 4 shows that such limitations occur at high subscriber densities, even when the amount of spectrum available is quite small.

4.2 Reference diagram

A reference diagram suitable for P-MP and MP-MP systems is shown in figure 2.

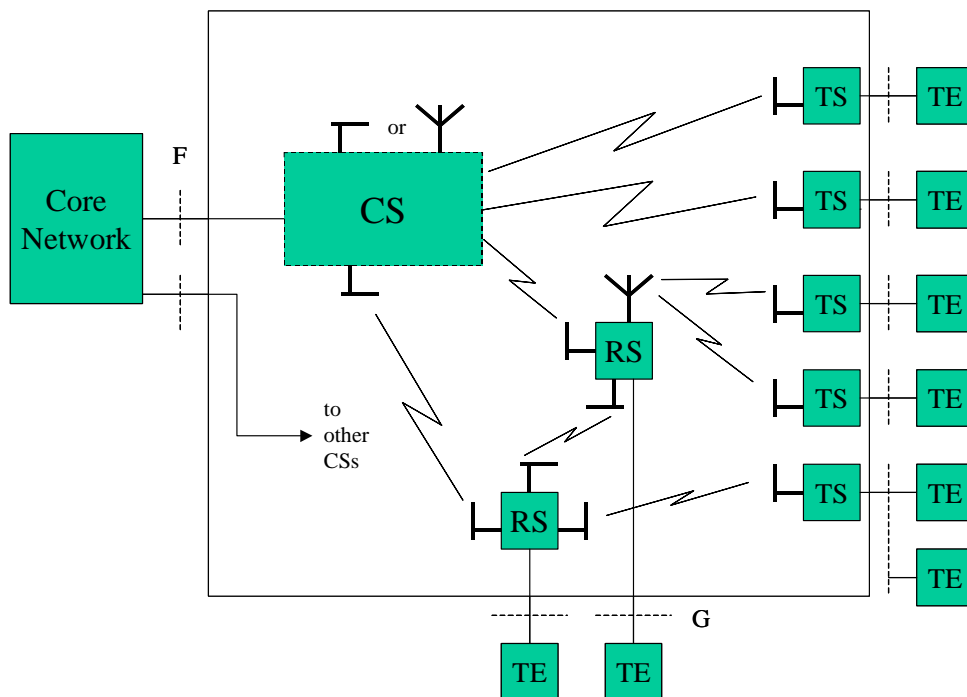

Figure 2: Reference diagram for P-MP and MP-MP systems

The numbers of each type of station in a real deployment can vary considerably. The diagram shows only each possible type of station and each possible type of connection between stations that may occur. In a typical mesh system, there are many Repeater Stations (RS) and a smaller number of Terminal Stations (TS) associated with each Central Station (CS). The CS can either be a Base Station (BS) of a P-MP system or a station in a MultiPoint-to-MultiPoint (MP-MP) system where there is an interface between a core network connection and the radio system.

Legend:

CS: The Central Station, which interfaces with the network. It can be integrated or divided into two units:

- i) the Central Controller Station (CCS);
- ii) the Central Radio Station (CRS) also called the radio unit which is the central baseband/radio transceiver equipment. More than one CRS may be controlled by one CCS.

In an MP-MP system, the CS is the station nearest to the core network. Typically, it uses directional antennas and more than one CRS is normally associated with a CCS.

TS: The Terminal Station (outstations with subscriber interfaces). A TS may serve more than one Terminal Equipment (TE). Some stations in MP-MP systems are Terminal Stations, but most also act as repeaters.

RS: The Repeater Station (radio repeater outstations with or without subscriber interfaces). An RS may serve one or more TS or RS.

TE: Terminal Equipment.

F: Interface between CS and Core Network - equivalent to the SNI in an access network.

G: Interface between TE and TS - equivalent to the UNI in an access network.

The reference diagram includes the system elements and interfaces for different types of Multipoint system (both P-MP and MP-MP). Not all system elements are necessarily deployed in any particular network. Although a single CS is possible, as shown, a typical system will deploy several CSs each with connection to the core network(s). The interconnection of CSs to core networks may be by means of radio links, optical fibre or other means.

User traffic flows to and from points of connection with external networks to the user TE interface(s). The system may behave as an access network, a broadcast network or combine the two. Subscriber to subscriber connections may also be provided in some networks, not routed via an external core network. The route from a network connection point to a user's TE interface may be via a single radio path or via one or more radio repeaters.

5 Deployment issues

5.1 Use as an access system

MP-MP systems can be used as access systems, in exactly the same way as P-MP systems. The system can be regarded as a "black box" which has interfaces to core networks and to end-users. The functionality of the "black box" is the same as that for a P-MP network, although the routing within the "black box" is different. The connection between access points and end user stations is via one or more radio links. The routing is controlled by the network management system. The configuration of links is not fixed, but varies to accommodate changes in subscriber numbers, service requirements and subscriber locations.

The MP-MP system differs from a P-P system in that it behaves as a complete network, rather than a series of individual links. In a P-P link system, each link is usually designed and deployed separately, uses fixed antennas and end points. In an MP-MP system, traffic routing, end-to-end service monitoring and intra system interference are all optimized by a network management subsystem. Routing, antenna directions, transmitter power, modulation scheme and other parameters can be varied from time to time to achieve an overall system performance that adapts to the needs of the end users.

5.2 Coverage

Coverage in this context is defined as the probability that any new randomly placed subscriber requesting service within the operator's nominal service area can be successfully connected. For mass market deployment, it is likely that very high values must be achieved (>95 %).

Most BWA systems operate in frequency bands that require line of sight connection between stations. Complete (100 %) coverage occurs when any randomly placed new subscriber within the designated service area can be connected to an existing base station or other station able to support a traffic connection. In practice, coverage is often severely limited by obstacles such as buildings, trees and terrain undulations that block the line of sight path. Coverage limitations in P-MP systems can be reduced by choosing high sites for the base stations, adding repeater stations to fill in specific areas (or to extend coverage outside the nominal cell) and by providing overlapping base station coverage. Mesh networks offer the possibility for greatly improved coverage, by allowing traffic to be routed via any subscriber station. Even at low network densities, the probability of finding a route from a convenient existing subscriber station is high. This is illustrated in figure 3.

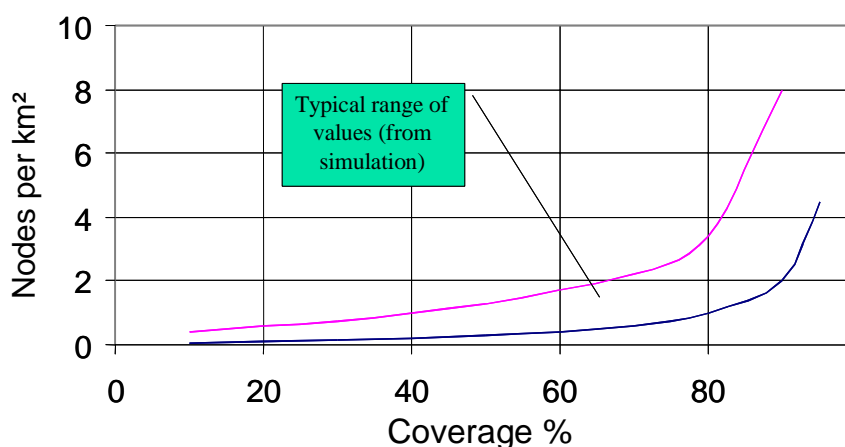

NOTE: The two curves in figure 3 represent the highest and lowest coverage values obtained from different sets of assumptions used in the simulations. These assumptions concern the minimum number of stations required to be visible from a given station. Practical deployments are expected to fall between the two curves.

Figure 3: Coverage of MP-MP systems

The coverage achieved depends on node density and on the precise way a mesh is interconnected. A system layout which assumes more interconnections per node requires a higher probability of coverage from each node and therefore gives a lower coverage result for a given node density. However, in all cases analysed, the results are very good. 90 % coverage is reached with node densities in the range 2 to 8/km². These low node densities are only experienced in the very early start-up phase of network deployment.

5.3 Spectrum Efficiency

Spectrum efficiency is an important factor in the choice of system architecture. A useful and meaningful measure of spectral efficiency is bit/s per MHz of spectrum per sq km of coverage. The spectrum efficiency of MP-MP networks can be very high and in many circumstances can be higher than that achieved by P-MP systems. At very low subscriber density, both architectures have similar efficiencies. However, at higher subscriber densities, the mesh architecture can give large gains in spectral efficiency. This arises because the link lengths are on average shorter, antennas are all directional and interference from any station is greatly reduced, since line of sight is only needed to any one nearby station and not to a fixed central station on a high site. Thus, frequencies can be re-used more often. A similar result could in theory be obtained with a P-MP architecture by successive cell-splitting and repeated reductions in cell size, as the system were expanded. In practice, such techniques are difficult, due to the fixed and directional nature of the subscriber stations.

Mesh networks can be designed economically to adapt to the constantly changing numbers and locations of subscribers, up to very high densities. The high spectrum efficiencies can thus readily be achieved in practical system deployments.

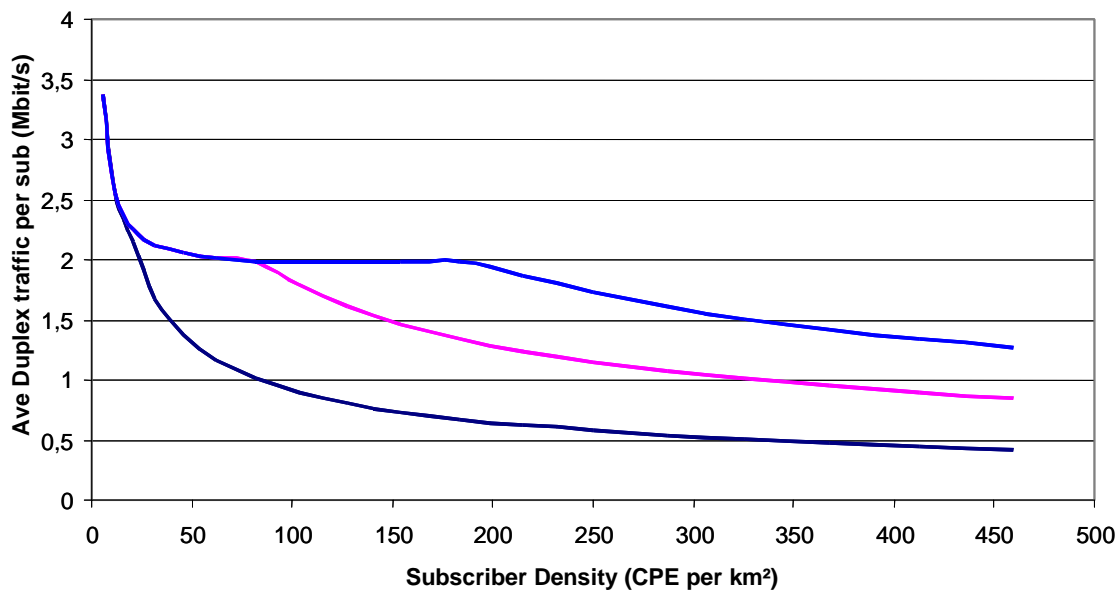

NOTE: The three curves show the traffic level for 2, 3 and 4 channels respectively, with traffic level increasing with the available number of channels.

Figure 4: Mesh spectral efficiency, from simulation

An estimate of the spectrum efficiency can be determined from modelling. Some modelling results are shown in figure 4. This shows the traffic delivered per subscriber for spectrum allocations of 2, 3 and 4 channels, at various subscriber densities. In making any comparison with a P-MP system, it should be noted that a channel in this analysis is a single (unpaired) 28 MHz channel, the system being assumed to operate in TDD mode.

5.4 Backhaul links

Spectrum calculations from clause 5.3 are in most cases sufficient to include backhaul links to appropriate points of connection with core networks. In a P-MP system, the number of base stations is kept reasonably low and locations are chosen on the basis of good coverage. In a mesh network, traffic from core networks can be inserted at any convenient TS/RS. Thus the probability of finding such a station near to a convenient core network access point is much higher. A link into the mesh can then be made using identical equipment and operating in the same frequency band as all the other links. Like other mesh links, these can be short and use low power.

5.5 Use of TDD or FDD

Mesh systems can operate with TDD or FDD channel arrangements. A TDD system is usually simpler to implement. Channel plans, such as CEPT/REC T/R 13-02 [11] can easily be deployed, in either case, operating with FDD. The complete analysis of interference between mesh and P-MP systems requires use of a simulation tool. This is described in annex C.

5.6 QoS issues

Different services have different requirements in terms of acceptable path delay, error-ratio performance and availability. Because MP-MP systems may use several radio hops to reach a particular end-user, there are constraints on design in order to achieve the necessary QoS requirements.

As the network density rises, the average number of links to a subscriber may increase, but at the same time the average hop length decreases. A limit has to be placed on the number of successive hops that can be allowed in order to meet the performance criteria. Since routing in a mesh network is not necessarily obvious or intuitive, modelling is required to determine how these constraints affect system deployment.

5.7 System capacity

The capacity of a mesh network is determined partly by the maximum bit rate on each link and partly by the arrangement of node stations in relation to the required traffic of each subscriber. A typical gross link capacity might be 100 Mbit/s, at which rate the spectral efficiencies and node densities shown in figure 4 can be achieved. Note that the gross link capacity is not the same as the delivered capacity to each user, since each link serves local subscribers and passes on data to other users in the system. The link capacity is readily measured and the system capacity can be calculated using the data from figure 4, which can be derived from simulation.

5.8 Applicability of existing TM4 specifications

TM4 specifications for BWA systems cover equipment parameters but do not specify the details of deployment. Such specifications, including EN 301 213-1 [5] and EN 301 213-3 [6], generally assume a P-MP architecture. The reference diagram allows for base stations, terminal stations and repeaters but the exact deployment is not specified. Systems could be built with one or many cells and one to several sectors per cell. Intra and inter system interference would depend on the actual configuration.

The remaining parts of the specifications specify a series of parameters relevant to co-existence of systems. Conformance to these specifications does not guarantee any particular level of co-existence (since that depends on the actual system configuration, which is not specified) but is presumably considered to be a reasonable basis for equipment design.

The study of co-existence is a complex matter, not dealt with in these standards. Certain cases have been studied in TR 101 853 [8], in CEPT SE19 (see bibliography) and in IEEE 802.16.2 [9] but a comprehensive set of results is not yet available.

MP-MP systems can be built to the same set of equipment parameters as are specified in EN 301 213-1 [5] and EN 301 213-3 [6]. The system architecture differs in detail but from the point of view of the reference diagram is only slightly different (see figure 2). The co-existence between P-MP and MP-MP is discussed in clause 6 and in annex C.

6 Co-ordination aspects

6.1 Co-existence between MP-MP and P-MP systems

This topic is discussed in more detail in annex C. A summary is given here.

The introduction of Fixed Wireless Access services in Europe, including the 24,5 GHz to 29,5 GHz band has led to a number of studies into co-existence of various types of system. System architectures and design parameters vary considerably in detail, making the analysis complex. Similar studies are taking place in the North American environment in IEEE project 802.16.2 [9]

The results of a detailed study [10] into co-existence between MP-MP systems and P-MP systems shows that geographical and frequency spacing can often be lower than those between P-MP systems. Some of the results are also indicative for P-MP to P-MP interference.

It is concluded that:

- Strict guard bands need not be deployed.
- Co-channel systems can be specially close or adjacent.
- Automated methods can be deployed, which significantly reduce co-ordination requirements between operators.

Annex A: Requirements for MP-MP systems operating in the 26 GHz and 28 GHz frequency bands

MP-MP systems operating in the 26 and 28 GHz frequency bands (24,25 GHz to 29,5 GHz frequency range) can operate using the same technical parameters as those specified in the relevant parts of the EN 301 213-1 [5] and EN 301 213-3 [6]. Although there are detailed system architectural differences, the services supported and the system interfaces can be the same. No new or different technical parameters need to be specified. The same frequency plan as specified in CEPT/REC T/R 13-02 [11] can be used. EN 301 213-1 [5] indicates the changes required to include both P-MP and MP-MP systems.

Annex B: Requirements for MP-MP systems operating in the 31 GHz and 32 GHz frequency band

MP-MP systems operating in the 31 GHz to 32 GHz frequency bands can operate using the same technical parameters as those specified for P-MP systems. The same frequency plan as specified by CEPT for the 31,8 GHz to 33,4 GHz frequency band can be used. A draft standard for 31 GHz to 32 GHz multipoint systems can be found in TM4 documents under work item DEN/TM04116 (see bibliography).

Annex C: Co-existence simulations for P-MP and MP-MP networks

C.1 Introduction

The introduction of Fixed Wireless Access (FWA) services in Europe, including the 24,5 GHz to 29,5 GHz band has led to a number of studies into co-existence of various types of system. System architectures and design parameters vary considerably in detail, making the analysis complex. Similar studies are taking place in the North American environment in IEEE project 802.16.2 [9]. A study in the UK [7], commissioned by the Radiocommunications Agency, has been completed and is publicly available. The conclusions reached so far vary considerably, despite the fact that the interference cases being analysed are essentially the same.

The results of a study into co-existence of MP-MP systems with P-MP systems are summarized in the following clauses. It shows that geographical and frequency spacing can be lower than those between P-MP systems. Some of the results are also indicative for P-MP to P-MP interference.

It is concluded that:

- Strict guard bands need not be deployed.
- Co-channel systems could in some cases be specially close or adjacent.
- Automated methods can be deployed, which significantly reduce co-ordination requirements between operators.

The analysis is based on reducing the interfering signal to -144 dBW/MHz at the victim station. This is a more severe (and arguably unnecessarily strict) requirement than that used in a number of other studies of the interference problem.

C.2 Methodology

The present document describes a method and results of simulating the power received from a complete MP-MP system (mesh) at a P-MP base station receiver or at a P-MP subscriber station receiver, in a cell adjacent to or overlapping the mesh. It shows that the interference created can be kept to a low level without the need to use highly directional terminal station antennas and without the need for strictly applied guard bands between systems operating in the same geographical area. The geometrical considerations are slightly different from those where only P-MP systems are considered. However, some of the interference mechanisms are very similar and the conclusions may well be applied also to some aspects of the P-MP case.

The simulation is performed using a purpose-written program, which repeatedly constructs random (but adequately legitimate) MP-MP (mesh) systems and integrates the total power received at a given range and elevation, based on system, beam and terrain geometries. The main analysis and all the results presented are based on systems operating in the 24 GHz to 28 GHz band, but can be applied to any frequency up to at least 43,5 GHz.

The analysis has concentrated mainly on interference created by an MP-MP system, which requires a statistical modelling approach. The interference received by MP-MP systems can be estimated by the same methodology required between P-MP systems, with slightly different parameter values (such as lower gain subscriber antennas). However, the value of such analysis is limited, since a practical MP-MP system will include a self-adjustment routine to minimize or eliminate such interference problems.

The cases analysed are as follows:

- a) MP-MP/P-MP co-channel, co-polar, adjacent area:
 - Multiple MP-MP subscribers to P-MP BS;
 - Multiple MP-MP subscribers to P-MP subscriber.
- b) MP-MP/P-MP same area, adjacent and near adjacent channels:
 - Multiple MP-MP subscribers to P-MP BS;
 - Multiple MP-MP subscribers to P-MP subscriber.

ALL cases include clear air and rain - faded calculations.

C.2.1 System modelling

A model has been created for a P-MP sector and for a corresponding MP-MP system, using antenna patterns appropriate to each type of system, a model for wanted path length distribution and a propagation model. The interference geometry for the model is shown in figure C.1.

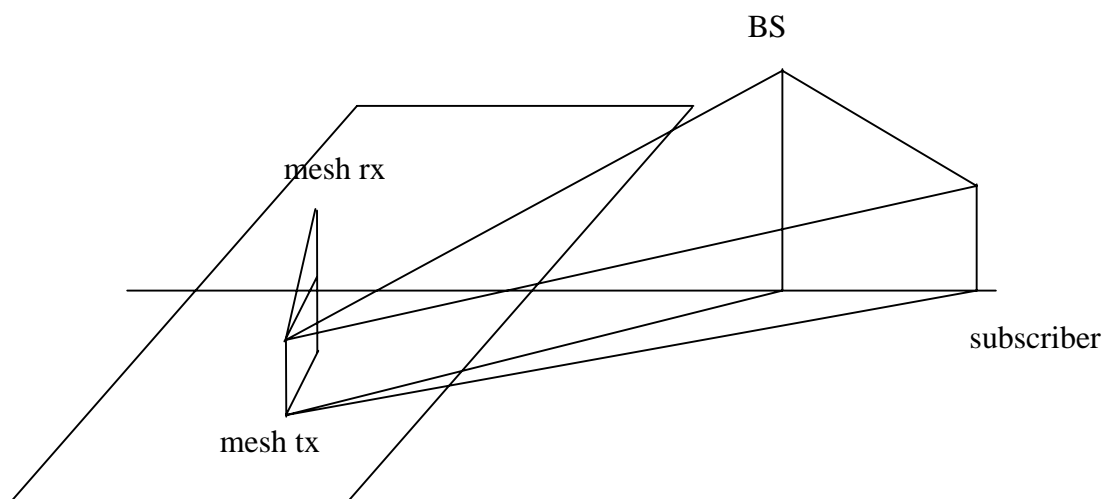

Figure C.1: Interference geometry

The main attributes of the model are:

- Monte-Carlo simulation with realistic MP-MP system parameters.
- Atmospheric attenuation to ITU-R Recommendation P.676-3 [2].
- Rain attenuation to ITU-R Recommendation P.840-2 [3].
- Dry, storm and frontal weather patterns considered.
- Interfering power summed at P-MP BS or TS, using full 3D geometry to compute distances and angles between lines of sight and antenna bore-sights.
- Line-of-sight propagation probabilities calculated from Rayleigh roof height distribution function as per CRABS WG3 report D3P1B [1].
- Effect of Automatic Power Control granularity (ATPC) included.
- P-MP CS1 and TS1 type RPEs for 24 GHz to 28 GHz band to EN 301 215 [4] with BS elevation profile ignored for realistic worst case. The gains assumed are 19 dBi for the CS1 antenna and 36 dBi for the TS1 antenna.

- MP-MP antenna RPE model for 24 GHz to 28 GHz band simulates an illuminated aperture with side-lobes to EN 301 215 [4].

C.2.2 Rain fading

Various rain fading scenarios have been considered in the simulations:

- The effects of individual storm cells.
- The effects of rain fronts.
- The effects of rain falling uniformly over the area.

All rain scenarios have only a small effect on the results

C.2.3 MP-MP system characteristics

MP-MP systems operate with short link paths, typically in the range 100 m to 1 km in length. Analysis of model mesh leads to link length distributions as shown in figure C.2.

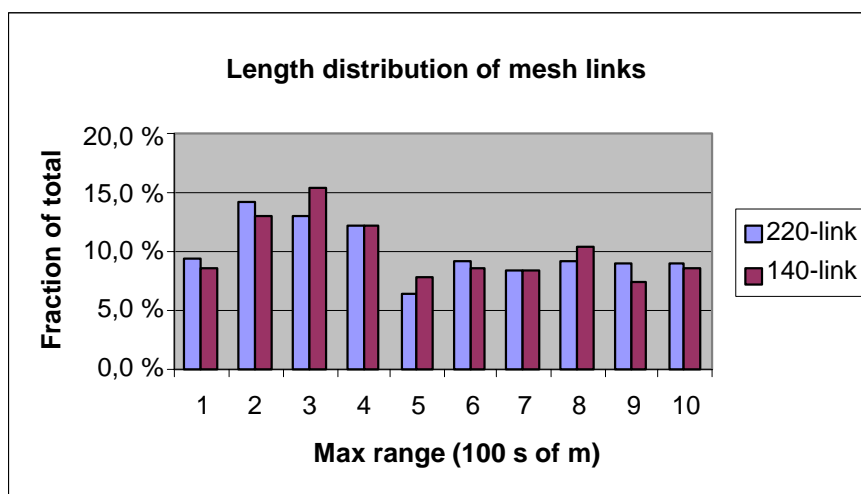

NOTE: The 220-link values are derived from a system model with 220 links.
The 140-link values are derived from a system model with 140 links.

Figure C.2: Distribution of link lengths in MP-MP system

The significance of this is that the MP-MP system operates with normalized received power levels, i.e. for each link the transmitter power is set to give just enough received signal level. A short link means a low transmit power. The same mechanism serves to reduce the levels of interference outside the mesh.

C.2.4 Propagation

The present document considers only line of sight paths for wanted signals and interference, using line of sight probabilities and free-space propagation.

The probability of interference line of sight is calculated from a model in which building heights are assumed to have a Rayleigh distribution, as in [1], although the probability calculations follow a slightly different method.

C.2.5 Antenna beam profiles

The current modelling for the 24 GHz to 28 GHz band is based on an antenna with half power beam-width of 9° in both azimuth and elevation. Slightly different values are likely to be optimum but the simulation results have not been found to be critical to moderate changes to the RPE.

A simplified model of the antenna pattern has been used. Although a real antenna will perform better than this model, it turns out not to be necessary from a co-existence point of view or from an intra system interference point of view. For the 24 GHz to 28 GHz band, the simplified model is based on a formula to represent the main beam and a side lobe pattern conforming to EN 301 215-2 [4] (TS1 antenna). This is shown in figure C.3.

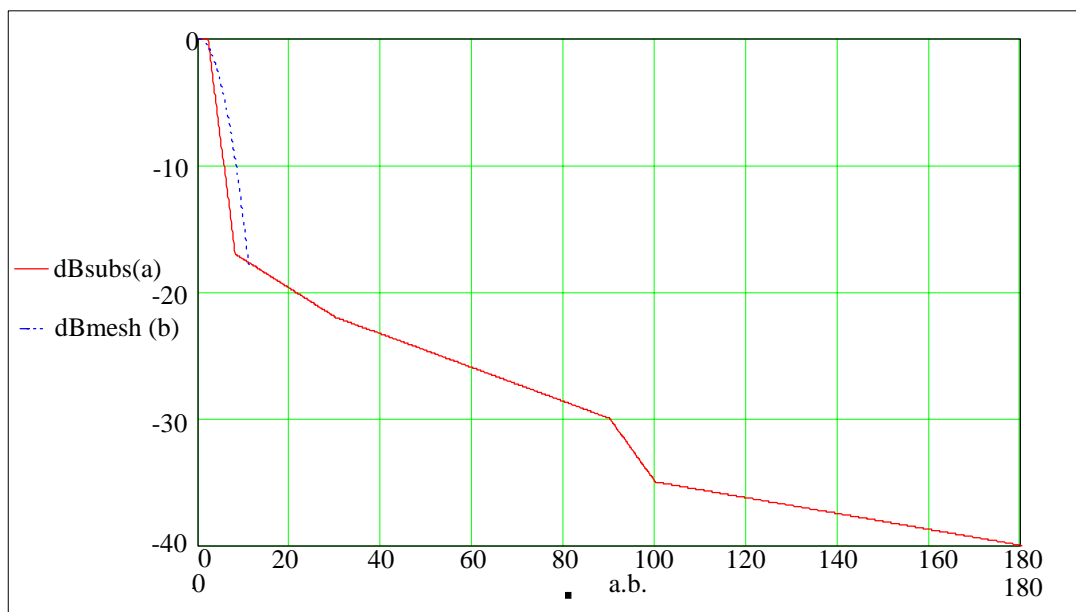

Figure C.3: Antenna RPE used for mesh nodes in the system model

This RPE is used to compute the reduction in power for interference lines of sight that are off bore-sight in azimuth.

C.2.6 Geometry

The basic arrangement of the model is shown in figure C.1. Given a node density and the percentage of nodes which can transmit simultaneously, the simulator places the appropriate number of mesh transmitters randomly within the prescribed mesh area at heights following the Rayleigh distribution. The Rayleigh distribution curve used is derived from the RAL CRABS report [1]. The Rayleigh height parameter (most probable building height), building density (number per square km) and proportion of an area covered by buildings can both be varied, allowing simulation of a wide range of environments, including urban, suburban and rural.

For each transmitter it then randomly places a receiver within the limits of link length and at an arbitrary angle. Conditions near the edge of the mesh are satisfied by repeating any receiver placements which fall to the right of the mesh boundary.

The effects of buildings are modelled by their density and fractional area, and terrain (the result of both building and land height variation) is modelled with a Rayleigh distribution.

The base station receiver horn is assumed to be a 90° sector aimed directly at the centre of the mesh, with a gain which is flat to $\pm 50^\circ$, falling off thereafter at 1dB every $4,5^\circ$.

C.2.7 Interfering power calculation

From each mesh transmitter and in line with the line of sight probability, the power received by the base station is computed. All these powers are summed, and the result rounded to the nearest dBm and assigned to a histogram bin, so that the relative probability of each power level can be estimated.

C.3 Adjacent area, co-channel case

C.3.1 Mesh to P-MP BS results - dry weather

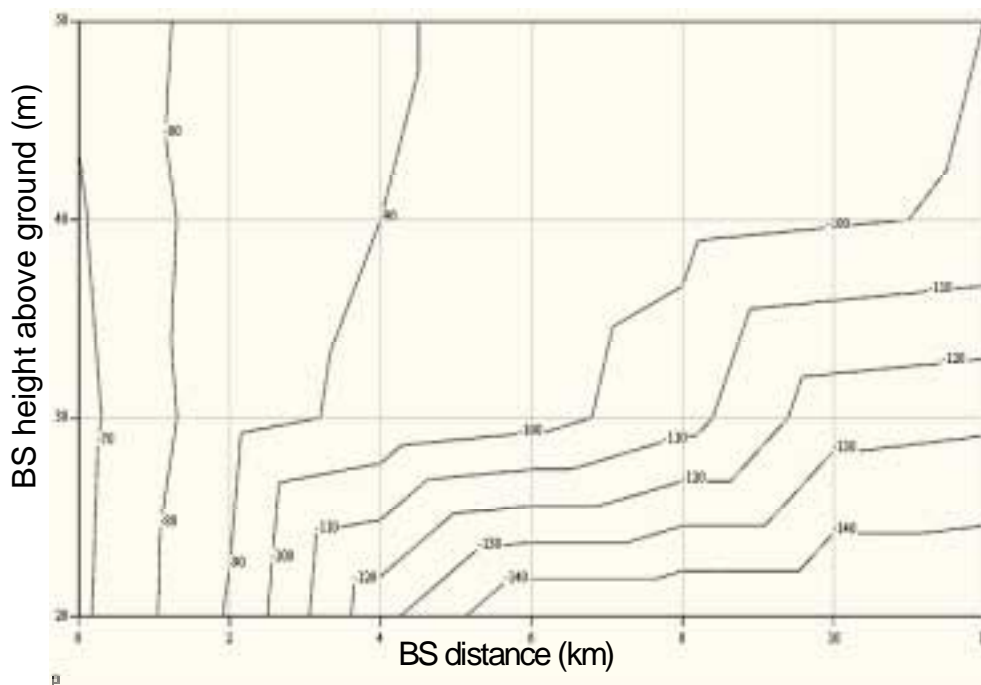

NOTE 1: Rayleigh parameter = 20 m.

NOTE 2: Simulation runs of a large number of randomly generated meshes have been run to generate a spatial picture of the interference levels. The results are produced for both dry weather and rain fading conditions. Figure C.4 shows results for the dry weather case. Note that the levels plotted are the maxima that occurred in the simulations, so could only have occurred for only 0,02 % of the time.

Figure C.4: BS Interference (dBm) as a function of BS distance (km) and of height (m)

The vertical axis is the BS (base station) antenna height, relative to ground level. The Mesh stations are at various heights determined by the Rayleigh distribution curve. The height that occurs with maximum probability is 20 m. The horizontal axis is the distance from the edge of the mesh to the centre of the P-MP cell. A series of contour lines are drawn, each corresponding to a different level of total interference received at the BS. The values considered are from -70 dBm to -140 dBm.

The mesh transmitters in the simulation use 28 MHz channels, transmitter power appropriate to 16QAM modulation and a frequency of 28 GHz. For a base station with 28 MHz channels, the -100 dBm contour corresponds to an interference level of -114,5 dBm/MHz, which is low enough to have negligible impact on performance. It can be seen that a 50 m high BS antenna needs a spacing of only 12 km from the mesh edge to receive negligible interference. Note that this and other results are very much worst-case figures (0,02 % probability was found when running a large number of simulations), so that most simulations give much better results, allowing closer spacings in most circumstances.

C.3.2 Effects of rain

Rain fading has also been considered and simulated. Two additional scenarios are considered:

- A single storm cell, randomly placed.
- A rain front, oriented in the most adverse position.

The results of one representative set of these simulations are shown in figure C.5 (logarithmic probability scale).

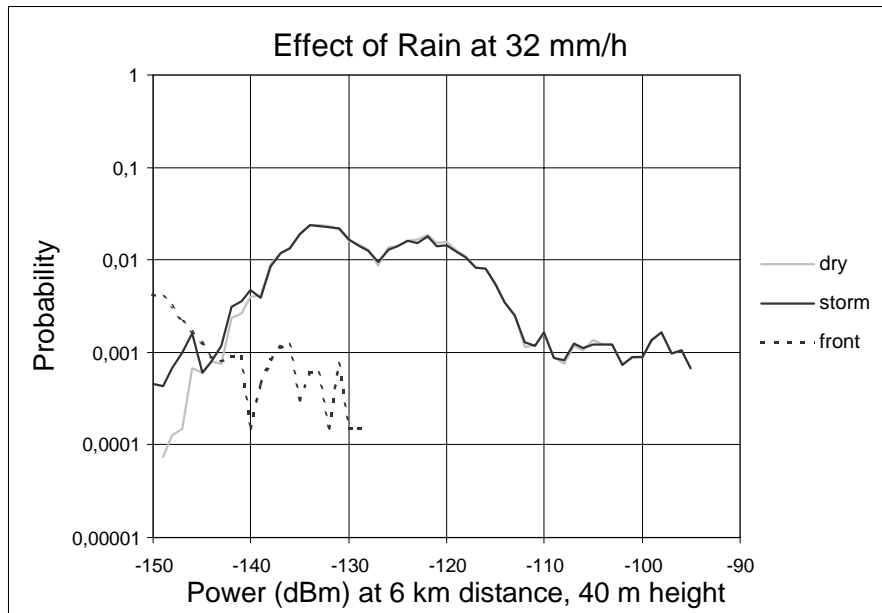

Figure C.5: Effects of rain fading (Co-channel systems, geographically spaced)

It can be seen that the effect of a rain - storm cell is negligible, except where interference is at a very low level (in which case the results are actually improved by rain). For a rain front, the worst-case result found shows a general reduction in interference during rainy periods. Very similar results were found for other base station heights and values of system spacing.

C.3.3 Mesh to P-MP TS interference

A similar analysis to the mesh - BS simulations can be carried out for the mesh to P-MP TS case. The P-MP parameters used are the EN 301 215 [4] TS1 antenna RPE and a gain of 36dBi. From a large number of simulations, two plots of results are presented, as follows:

- a) with the P-MP subscriber antenna pointing horizontally towards the mesh:

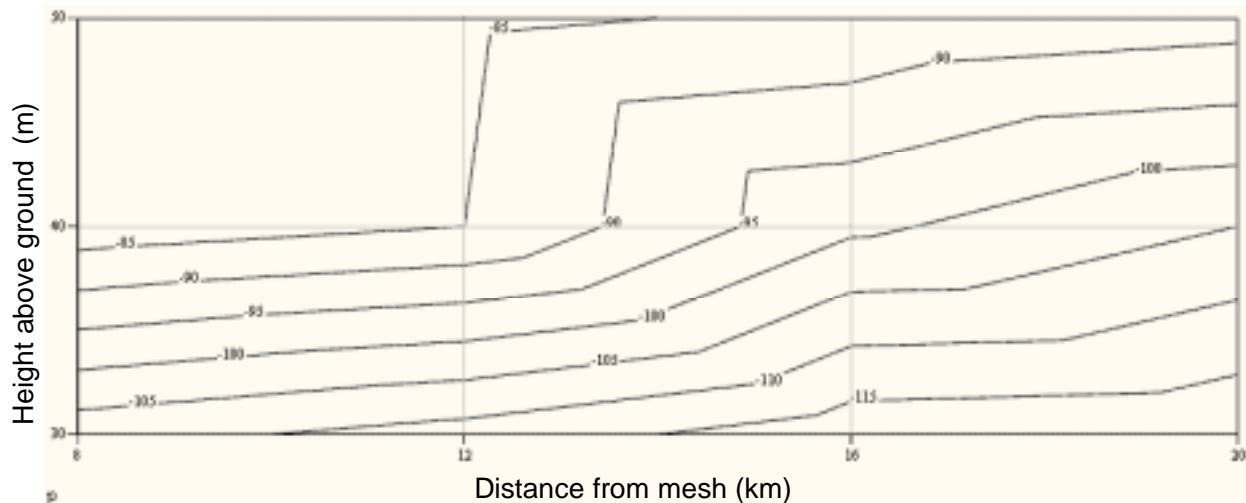

Figure C.6: TS Interference (dBm) as a function of TS distance from mesh (km) and TS height (m)

This plot shows that for antenna heights up to 35 m an approximate spacing of 12 km is required between the P-MP subscriber and the edge of the mesh to reduce interference to the required threshold. Thus, in most cases, the mesh to hub spacing requirement will dominate.

b) with the P-MP subscriber antenna pointing towards a BS 50 m high, 12 km from mesh:

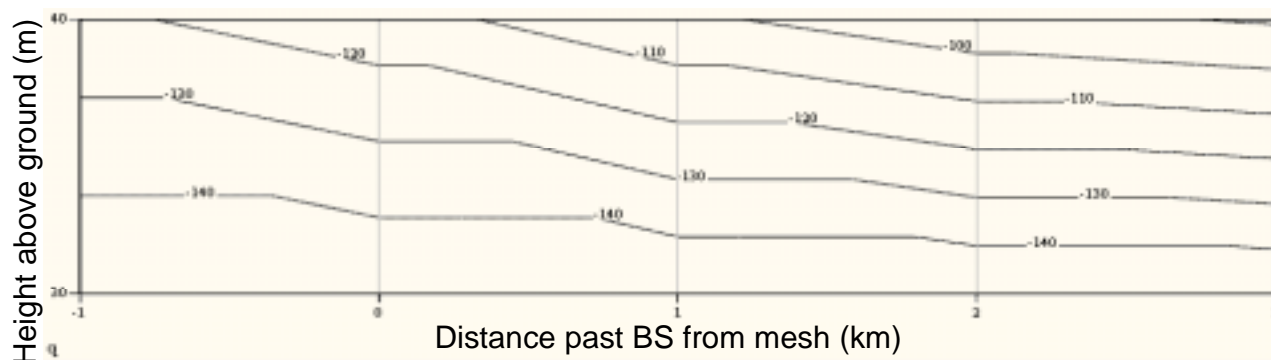

Figure C.7: TS Interference (dBm) as a function of TS distance past BS (km) and TS height (m)

This is a more realistic case and again shows that the nominal spacing required for the BS will be the controlling factor. All P-MP subscribers that are closer than the BS (12 km in this example) receive negligible interference.

The effects of rain fading are, as for the BS case, negligible.

C.3.4 Conclusions for the co-channel case

Mesh systems do not generate high levels of external interference. The analysis, based on a large number of simulations of relatively high-density random mesh configurations, show that system spacings can generally be less than those required for P-MP systems. The analysis is valid for TDD and FDD systems.

In a practical mesh system, self-adaptation to avoid interferers will be a standard feature. The result will be a reduction in the necessary spacing of co-channel systems, which in some cases could be reduced to zero. In any event, a guideline based on random (non adapting) mesh systems is conservative.

A summary of the conclusions for the co-channel case is as follows:

- 1) A mesh system does not need high gain antenna with strongly suppressed side-lobes in order to reach acceptable levels of external interference.
- 2) The effects of rain fading are very small.
- 3) There is no BS to BS interference (an MP-MP system does not use BSs).
- 4) Co-channel system geographical spacing can be low.
- 5) Self-adjustment of an MP-MP system will mitigate many or all of the potential interference cases between individual stations.

C.4 Same area adjacent/near adjacent channel case

C.4.1 The interference model

This model is similar to that used for studying individual interferers, but differs in the following ways.

The mesh

Mesh nodes are randomly distributed, so that each mesh link is determined by two random nodes chosen such that their separation lies between 50 m and 1 000 m.

The inclination of each mesh link is limited to a maximum of $4,5^\circ$ from the horizontal and is determined by the Rayleigh-distributed heights of its terminal nodes.

The P-MP cell

Subscriber antennas are mounted at Rayleigh-distributed heights but all have line of sight to the BS antenna.

Propagation

Propagation is considered for uniformly dry conditions, and also for a randomly-placed weather front (an approximately linear boundary between wet and dry weather) and for a single randomly-placed storm (circular area of rain).

Interference

The probability that a line of sight exists from any mesh subscriber to the P-MP BS is derived assuming a Rayleigh height distribution for randomly-placed intervening buildings. The elevation angle of the interference line-of-sight is calculated from the height difference between the two interfering elements.

Weather

Apart from uniformly dry and wet weather, calculations were performed for:

- a randomly positioned and orientated weather front dividing dry from wet propagation conditions;
- a single randomly positioned rainstorm of diameter between 1 km and 3 km.

C.4.2 Results for mesh to P-MP BS - adjacent channel

Results are presented for interference caused by a mesh. Interference from specific cellular configurations to a mesh can also be simulated, but given the way in which a mesh avoids interference in normal operation, it is not clear what value such results might have. In a practical mesh, each station will measure incoming interference from all sources and directions and provide this information to a database. The system configuration will then be adjusted automatically to minimize or eliminate the incoming interference. This means that the random orientation assumed in the simulations is very pessimistic and will over-estimate the amount of interference actually experienced.

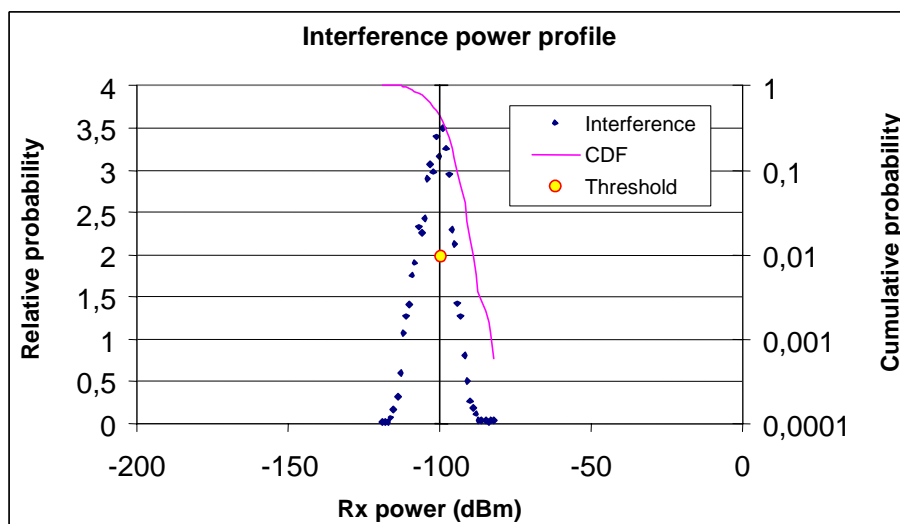

Figure C.8: Aggregate mesh to P-MP BS: dry weather, adjacent channel

The received total power profile is very similar under all conditions. However, the coloured curve (solid curve) in figure C.9 shows the probability that the received power exceeds any given value, and table C.1 shows how the probability of exceeding the receive threshold varies between scenarios.

Table C.1: Summary of Results for mesh to P-MP BS same area, adjacent channel simulations

Weather	Max. interference power	Probability of exceeding -100 dBm threshold
Dry	-82,2 dBm	37,4%
Random rain front	-78,5 dBm	31,9%
Random rain storm	-79,4 dBm	36,0%
Uniform rain	-78,7 dBm	28,2%

It can be seen that the highest value for interference power exceeds the desired interference threshold (-100 dBm) by around 22 dB, so that by requiring a single-channel guard band (21 dB additional attenuation, taken from ETSI Net Filter Discrimination information in [8]) interference can largely be avoided under all scenarios.

C.4.3 Effect of Guard Bands

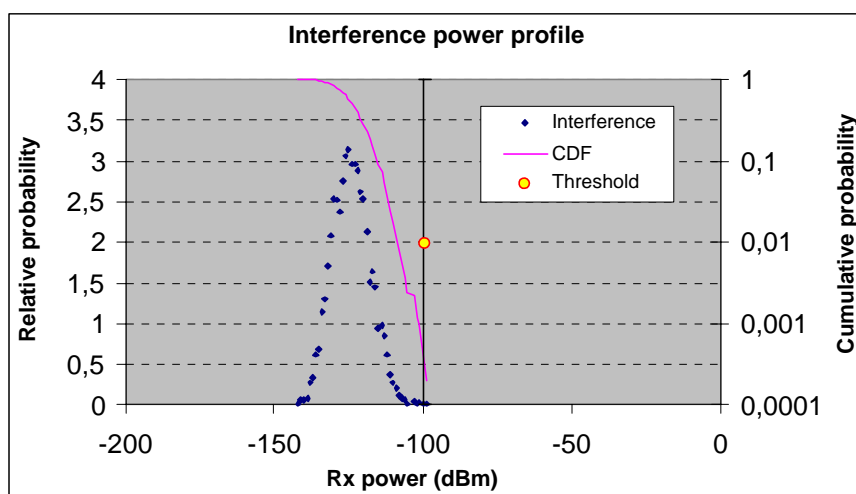
**Figure C.9: Aggregate mesh to P-MP BS, uniformly wet weather, single channel guard band**

The results of the simulation with a single (28 MHz) guard channel between the mesh and P-MP cell are shown in figure C.9. The worst scenario of those computed is shown, with uniform wet weather conditions applied, although other weather conditions have negligible effect on the results. This corresponds to a 0,02 % (and therefore negligible) probability that the -100 dBm interference threshold is exceeded. The full table of probabilities is shown in table C.2.

Table C.2: Summary of Results for mesh to P-MP BS, same area, single guard channel case

Weather	Max. interference power	Probability of exceeding -100 dBm threshold
Dry	-103,2 dBm	0,00 %
Random rain front	-99,7 dBm	0,02 %
Random rain storm	-100,4 dBm	0,00 %
Uniform rain	-99,7 dBm	0,02 %

Since this analysis is based on randomly oriented mesh links, the results are pessimistic. A real mesh will automatically avoid interference to and from the BS as much as possible. However, it does show that, for all weather conditions, mesh and P-MP systems are easily co-ordinated in the same area, with a channel spacing similar to or less than that required between two P-MP systems.

C.4.4 Results for Mesh to P-MP TS

Interference from a mesh to a single P-MP TS has also been modelled. The scenario is only slightly different from the case of two P-MP TSs. It has relatively low probability of occurrence but, where interference occurs, it could have a high level (in an extreme case, receiver blocking is possible), as with the case of P-MP systems.

A P-MP TS is most susceptible at the edge of a P-MP cell. The results below are therefore reported assuming such a TS.

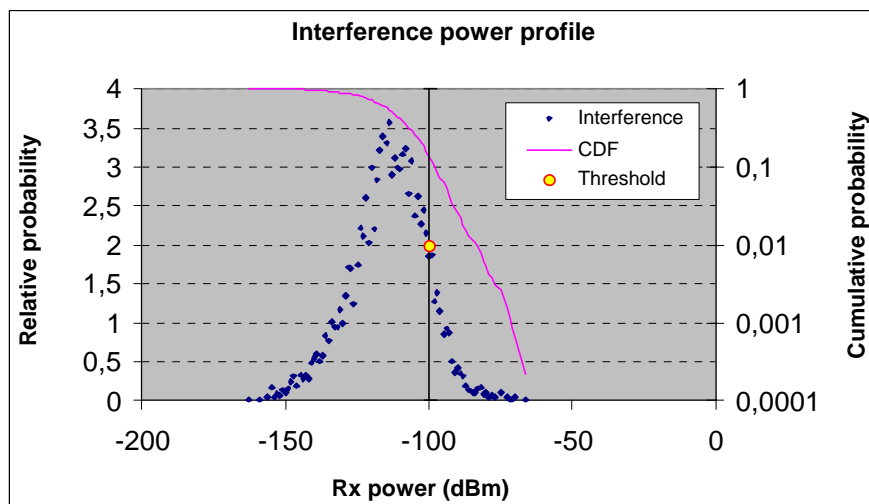

Figure C.10: Aggregate mesh to cell-edge P-MP TS, dry weather, adjacent channel

The interference criterion for the P-MP TS assumes that it is operating at its noise threshold.

Table C.3: Summary of results for the mesh to P-MP TS, same area, adjacent channel case

Weather	Max. interference power	Probability of exceeding -100 dBm threshold
Dry	-66,5 dBm	11,2 %
Random rain front	-70,0 dBm	12,1 %
Random rain storm	-70,9 dBm	11,9 %
Uniform rain	-64,7 dBm	12,3 %

Table C.3 shows that the probability of interference is insensitive to the weather (except that in dry weather the subscriber will be operating above its receive threshold sensitivity, and so the allowable interference will be governed by C/I rather than the receiver noise level).

The maximum interference exceeds the threshold by around 35 dB.

C.4.5 Effect of guard bands

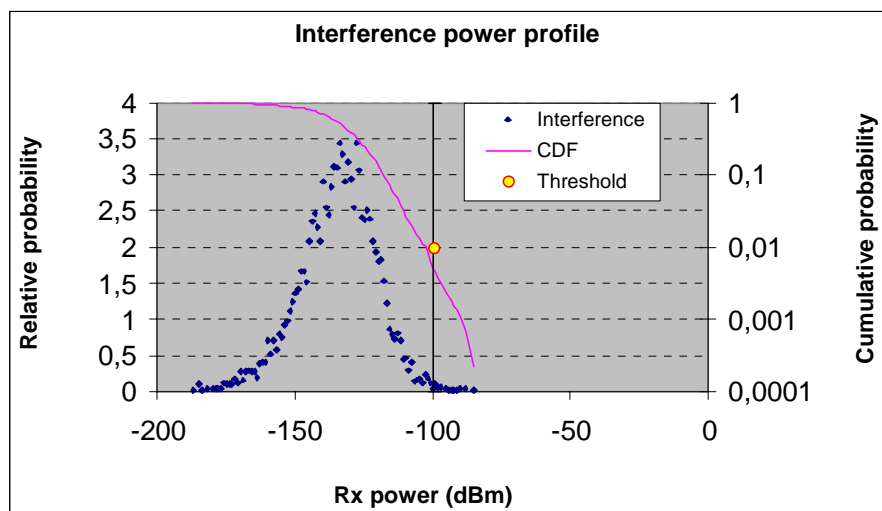

Figure C.11: Mesh to cell-edge P-Mp TS, random rain front, single channel guard band

If a single channel guard band is provided between the systems, then the maximum interference power still exceeds the threshold by around 15 dB, but the probability of interference has now reduced to a very low value of around 0,35 % (i.e. only 0,35 % of randomly chosen mesh layouts leads to a figure above the required noise threshold).

A two-channel guard band would eliminate all cases of interference (other than where blocking dominates the interference) but would clearly be wasteful, since the probability is very low.

C.4.6 Conclusions for systems in overlapping areas

The analysis by simulation of interference from a large number of relatively high density, randomly chosen, mesh configurations shows that interference to a P-MP system in the same area (both with BSs and P-MP TSs) will be at a very low level when a single channel guard band is deployed between systems. This is valid for both FDD and TDD implementations.

The results are pessimistic, because, in practice, mesh configurations are not random. They are chosen so as to minimize intra-system and inter-system interface. In fact, a practical system can do this automatically. The result is that in many or most cases there is a possibility to reduce the guard band requirement. The reciprocal cases (P-MP to Mesh) are still being analysed. A different methodology is required, since the BSs and P-MP TSs are not pointed randomly. However, preliminary results show that similar guidelines on channel spacing will be satisfactory.

The type of weather has a minor effect on the total probability of interference; in general, the increased transmit power required by wet weather is also largely attenuated by the rain and so the net effect is small.

Annex D: Bibliography

CEPT SE19 Draft Report SE19(99)195: "Preliminary SE19 Report on the analysis of the co-existence of two FWA cells in the 24,5-29,5 GHz bands".

Draft ETSI DEN/TM04116: "Multipoint digital radio systems operating in the 31,0 to 33,4 GHz frequency range".

History

Document history		
V1.1.1	February 2002	Publication