

## **Broadband Radio Access Networks (BRAN); HIPERACCESS; System Overview**

---



---

Reference

DTR/BRAN-0030004

---

Keywords

access, ATM, broadband, HIPERACCESS,  
local loop

**ETSI**

650 Route des Lucioles  
F-06921 Sophia Antipolis Cedex - FRANCE

Tel.: +33 4 92 94 42 00 Fax: +33 4 93 65 47 16

Siret N° 348 623 562 00017 - NAF 742 C  
Association à but non lucratif enregistrée à la  
Sous-Préfecture de Grasse (06) N° 7803/88

---

**Important notice**

Individual copies of the present document can be downloaded from:

<http://www.etsi.org>

The present document may be made available in more than one electronic version or in print. In any case of existing or perceived difference in contents between such versions, the reference version is the Portable Document Format (PDF). In case of dispute, the reference shall be the printing on ETSI printers of the PDF version kept on a specific network drive within ETSI Secretariat.

Users of the present document should be aware that the document may be subject to revision or change of status. Information on the current status of this and other ETSI documents is available at

<http://portal.etsi.org/tb/status/status.asp>

If you find errors in the present document, send your comment to:

[editor@etsi.fr](mailto:editor@etsi.fr)

---

**Copyright Notification**

No part may be reproduced except as authorized by written permission.  
The copyright and the foregoing restriction extend to reproduction in all media.

© European Telecommunications Standards Institute 2002.  
All rights reserved.

**DECT™**, **PLUGTESTS™** and **UMTS™** are Trade Marks of ETSI registered for the benefit of its Members.  
**TIPHON™** and the **TIPHON logo** are Trade Marks currently being registered by ETSI for the benefit of its Members.  
**3GPP™** is a Trade Mark of ETSI registered for the benefit of its Members and of the 3GPP Organizational Partners.

# Contents

Intellectual Property Rights .....	5
Foreword.....	5
Introduction .....	5
1 Scope .....	6
2 References .....	6
3 Definitions and abbreviations.....	8
3.1 Definitions .....	8
3.2 Abbreviations .....	8
4 Context of documents.....	10
4.1 General documents .....	10
5 Users, services and facilities .....	11
5.1 Who is HIPERACCESS for?.....	11
5.2 Traffic and service requirements .....	12
5.3 Performance issues .....	12
5.4 Comparison for HIPERACCESS .....	12
5.5 Application as UMTS backhaul .....	13
5.5.1 Rationale.....	13
5.5.2 Functional requirements .....	13
6 System features and architecture.....	14
6.1 General .....	14
6.2 Physical (PHY) layer.....	18
6.3 DLC.....	20
7 Network aspects .....	25
7.1 System configurations .....	25
7.2 Interfaces .....	26
7.3 Other interfaces .....	26
7.4 Security aspects .....	26
7.5 Network performance.....	27
7.6 ATM requirements .....	27
7.6.1 Traffic control requirements .....	27
7.7 Network management.....	27
7.8 System gain, coverage and deployment .....	28
7.8.1 Evaluation of required system gain.....	28
7.8.1.1 Assumptions and requirements .....	28
7.8.1.2 System gain calculation.....	28
7.8.2 Reference radio system conditions .....	29
7.8.3 Void .....	30
7.8.4 Availability and quality BER thresholds .....	30
7.8.5 RF Receiver input level thresholds .....	30
7.8.6 RF transmit output power .....	30
7.8.7 Coverage range sensitivity.....	31
7.8.8 Void .....	31
7.8.9 Consequences due to the interference and PTx tolerances .....	31
7.8.9.1 Interference scenarios.....	31
7.8.9.2 Coverage reduction due to interference and tolerances (PHY mode 1) .....	32
7.8.9.3 Availability of the radio link at 64QAM (PHY mode M4) .....	32
7.8.9.4 RF Spectrum emission issues .....	33
7.8.10 Adjacent and Co-channel Interference requirements .....	33
7.9 Multi-dwelling scenarios.....	34
8 Traffic and spectrum aspects.....	34
8.1 Service hypothesis.....	34

8.2	Area definition parameters .....	35
8.3	Capacity per radio channel .....	36
8.4	Traffic model.....	36
8.5	Spectrum evaluation.....	36
8.5.1	Case 1: high residential area .....	36
8.5.2	Case 2: high business concentration areas .....	37
8.6	Fixed link requirements.....	37
8.7	UMTS Spectrum Requirements .....	37
9	Radio aspects.....	38
9.1	Frequency bands and channel plans .....	38
9.2	System co-ordination.....	38
9.3	Spectrum sharing.....	38
9.4	Multiple operators .....	39
10	Interoperability aspects.....	39
10.1	Definition of interoperability.....	39
10.2	Requirements for interoperability.....	39
11	Requirements for co-existence .....	40
<b>Annex A: Application of HIPERACCESS system with passive optical network.....</b>		<b>42</b>
A.1	Network aspects .....	42
A.2	Architecture.....	42
A.3	System configuration.....	43
A.3.1	Optical Line Termination .....	43
A.3.2	Optical Network Unit .....	43
A.3.3	Optical Distribution Network .....	43
A.3.4	HIPERACCESS system configuration.....	43
A.3.5	Functional reference model for radio in FSAN Platform .....	44
History .....		47

---

## Intellectual Property Rights

IPRs essential or potentially essential to the present document may have been declared to ETSI. The information pertaining to these essential IPRs, if any, is publicly available for **ETSI members and non-members**, and can be found in ETSI SR 000 314: *"Intellectual Property Rights (IPRs); Essential, or potentially Essential, IPRs notified to ETSI in respect of ETSI standards"*, which is available from the ETSI Secretariat. Latest updates are available on the ETSI Web server (<http://webapp.etsi.org/IPR/home.asp>).

Pursuant to the ETSI IPR Policy, no investigation, including IPR searches, has been carried out by ETSI. No guarantee can be given as to the existence of other IPRs not referenced in ETSI SR 000 314 (or the updates on the ETSI Web server) which are, or may be, or may become, essential to the present document.

---

## Foreword

This Technical Report (TR) has been produced by ETSI Project Broadband Radio Access Networks (BRAN).

---

## Introduction

There is an increasing need for delivery of broadband digital communications services to individuals, households and businesses of all sizes. High Speed Internet and Video are examples of service demanded for a variety of business, household management and leisure activities. In response to these trends, HIPERACCESS (High Performance Radio ACCESS) Systems are being specified for use by residential customers, and by small to medium sized enterprises (SMEs). They will support a wide range of voice and data services, using a radio system to connect the premises to other users and networks and offering "bandwidth on demand" to deliver the appropriate data rate needed for the service chosen at any one time.

HIPERACCESS standard will define the requirements and the technical specifications for a single interoperable system. A key objective is to create the conditions for a large market take-up leading to a low-cost per user and this requires to limit the number of different options. Nevertheless the standard can comprise few options that might be needed to address different frequency bands and channelization schemes.

The topology of HIPERACCESS is point-to-multipoint. User terminals will support one or more of a wide range of voice and data services, using a radio system providing fixed wireless access and to connect user premises to external core networks, which may be based on ATM, IP or UMTS services.

---

# 1 Scope

The present document has been produced to assist the following potential readers to understand the aims and principal features required of the HIPERACCESS standards:

- Regulatory bodies responsible for spectrum allocation and licensing of systems.
- Members of other BRAN groups.
- Members of other ETSI projects and bodies.
- Potential manufacturers of HIPERACCESS systems.
- Potential operators of HIPERACCESS systems.
- Developers of the detailed HIPERACCESS standards.

The present document addresses particularly the following issues:

- A summary of what HIPERACCESS will deliver for users.
- A comparison with other technologies and context with other BRAN solutions.
- The scope of standardization proposed (including interfaces to be standardized).
- A view of the expected licensing regime and an estimation of the required spectrum.

The present document describes the HIPERACCESS systems and is intended to serve as a basis for development of HIPERACCESS technical specifications.

---

# 2 References

For the purposes of this Technical Report (TR), the following references apply:

- [1] ITU-T Recommendation G.723.1: "Dual rate speech coder for multimedia communications transmitting at 5.3 and 6.3 kbit/s".
- [2] TS 102 003: "Broadband Radio Access Networks (BRAN); Common DLC layer Service Interface for BRAN Systems".
- [3] ETSI TR 101 177: "Broadband Radio Access Networks (BRAN); Requirements and architectures for broadband fixed radio access networks (HIPERACCESS)".
- [4] ETSI TR 101 378: "Broadband Radio Access Networks (BRAN); Common ETSI - ATM Forum reference model for Wireless ATM Access Systems (WACS)".
- [5] ISO 7498-1: "Information technology - Open Systems Interconnection - Basic Reference Model: The Basic Model".
- [6] ISO 10022: "Information technology - Open Systems Interconnection - Physical Service Definition".
- [7] ISO 8886: "Information technology - Open Systems Interconnection - Data link service definition".
- [8] ITU-R Recommendation SM.329-7: "Spurious Emissions".
- [9] ITU-R Recommendation F.1191-2: "Bandwidths and unwanted emissions of digital fixed service systems".
- [10] ITU-T Recommendation G.902: "Framework Recommendation on functional access networks (AN) - Architecture and functions, access types, management and service node aspects".

- [11] ITU-T Recommendation G.982: "Optical access networks to support services up to the ISDN primary rate or equivalent bit rates".
- [12] ITU-T Recommendation G.983.1: "Broadband optical access systems based on Passive Optical Networks (PON)".
- [13] ITU-T Recommendation I.732: "Functional characteristics of ATM equipment".
- [14] ITU-T Recommendation I.321: "B-ISDN protocol reference model and its application".
- [15] ITU-T Recommendation I.731: "Types and general characteristics of ATM equipment".
- [16] ITU-T Recommendation I.356: "B-ISDN ATM layer cell transfer performance".
- [17] ITU-T Recommendation I.361: "B-ISDN ATM layer specification".
- [18] ITU-T Recommendation I.363: "B-ISDN ATM Adaptation Layer (AAL) specification".
- [19] ITU-T Recommendation I.371: "Traffic control and congestion control in B-ISDN".
- [20] ETSI EN 301 163-1-1: "Transmission and Multiplexing (TM); Generic requirements of Asynchronous Transfer Mode (ATM) transport functionality within equipment; Part 1-1: Functional characteristics and equipment performance".
- [21] ITU-T Recommendation M.3010: "Principles for a Telecommunications management network".
- [22] ITU-T Recommendation I.610: "B-ISDN operation and maintenance principles and functions".
- [23] ITU-R Recommendation P.530-6: "Propagation data and prediction methods required for the design of terrestrial line-of-sight systems".
- [24] ITU-R Recommendation P.838: "Specific attenuation model for rain for use in prediction methods".
- [25] ITU-R Recommendation P.837-1: "Characteristics of precipitation for propagation modelling".
- [26] RFC 2684: "Multiprotocol Encapsulation over ATM Adaptation Layer 5".
- [27] Doc SE19(01)23 rev.2: "Draft ERC-Report on Fixed Service Requirements for UMTS/IMT-2000 Networks".
- [28] ETSI TS 101 999: "Broadband Radio Access Networks (BRAN); HIPERACCESS; PHY protocol specification".
- [29] ETSI TS 102 000: "Broadband Radio Access Networks (BRAN); HIPERACCESS; DLC protocol specification".
- [30] ITU-T Recommendation G.804: "ATM cell mapping into Plesiochronous Digital Hierarchy (PDH)".
- [31] ITU-T Recommendation I.430: "Basic user-network interface - Layer 1 specification".
- [32] ITU-T Recommendation I.431: "Primary rate user-network interface - Layer 1 specification".

## 3 Definitions and abbreviations

### 3.1 Definitions

For the purposes of the present document, the following terms and definitions apply:

**bandwidth on demand:** ability to deliver a dynamically varying data rate appropriate to the particular service being demanded

**downlink:** data direction from an Access Point (AP) to an Access Termination (AT)

**uplink:** data direction from an Access Termination (AT) to an Access Point (AP)

### 3.2 Abbreviations

For the purposes of the present document, the following abbreviations apply:

ABR	Available Bit Rate
AP	Access Point
APC	Access Point Controller
APT	Access Point Transceiver
ARQ	Automatic Repeat reQuest
AT	Access Termination
ATM	Asynchronous Transfer Mode
ATPC	Automatic Transmission Power Control
BER	Bit Error Rate
BRAN	Broadband Radio Access Networks
CAC	connection admission control
CBR	Constant Bit Rate
CCI	Co-Channel Interference
CES	Connection Endpoint Suffix
CLP	cell loss priority
CRS	Central Radio Station
DL	DownLink
DLC	Data Link Control
DVB	Digital Video Broadcasting
EFCI	Explicit Forward Congestion Indication
EIRP	Equivalent Isotropic Radiated Power
EMS	Element Management System
FDD	Frequency Division Duplex
FEC	Forward Error Correction
FSAN	Full Service Access Network
FTTx	Fibre To The (x = Cab Cabinet, x = C Curb, x = B Building, x = H Home)
HA	Home Automation
H-FDD	Half duplex FDD
HIPERACCESS	HIgh PERformance Radio ACCESS network
HIPERLAN	HIgh PERformance Local Area Network
IP	Internet Protocol
ISDN	Integrated Services Digital Network
ITU	International Telecommunications Union
IWF	InterWorking Function
LAN	Local Area Network
LLC	Logical Link Control
LoS	Line of Sight
MAC	Medium Access Control
MBH	Mean Busy Hour
MDU	Magnetic Disk Unit
NFD	Net Filter Discrimination
NNI	Network Node Interface



NPC	Network Parameter Control
OAM	Operation And Maintenance
ODN	Optical Distribution Network
ODU	OutDoor Unit
OLT	Optical Line Termination
ONU	Optical Network Unit
PDU	Protocol Data Unit
PHY	PHYSical (layer of protocol)
PMP	Point to MultiPoint
PON	Passive Optical Network
POTS	Plain Old Telephone Service
PRA	Primary Rate Access
PtP	Point-to-Point
QAM	Quadrature Amplitude Modulation
QoS	Quality of Service
QPSK	Quadrature Phase Shift Keying
RF	Radio Frequency
RNC	Radio Network Controller
RS	Reed-Solomon
SME	Small to Medium sized Enterprise
SNI	Secure Network Interface
SNR	Signal to Noise Ratio
TDD	Time Division Duplexing
TDM	Time Domain
TDMA	Time Division Multiple Access
TS	Terminal Station
UBR	Unspecified Bit Rate
UIUC	Uplink Interval Usage Code
UL	UpLink
UMTS	Universal Mobile Telecommunication System
UNI	User-Network Interface
UPC	Usage Parameter Control
VBR	Variable Bit Rate
VoD	Video on Demand
WCS	Wireless ATM Convergence Sublayer
xDSL	x (= generic) Digital Subscriber Line

## 4 Context of documents

The present document is only concerned with HIPERACCESS, for which a proposed document structure is given in figure 1. HIPERACCESS provides outdoor, high speed (at least 25 Mbit/s data rate) fixed radio access to customer premises and is capable of supporting multi-media applications.

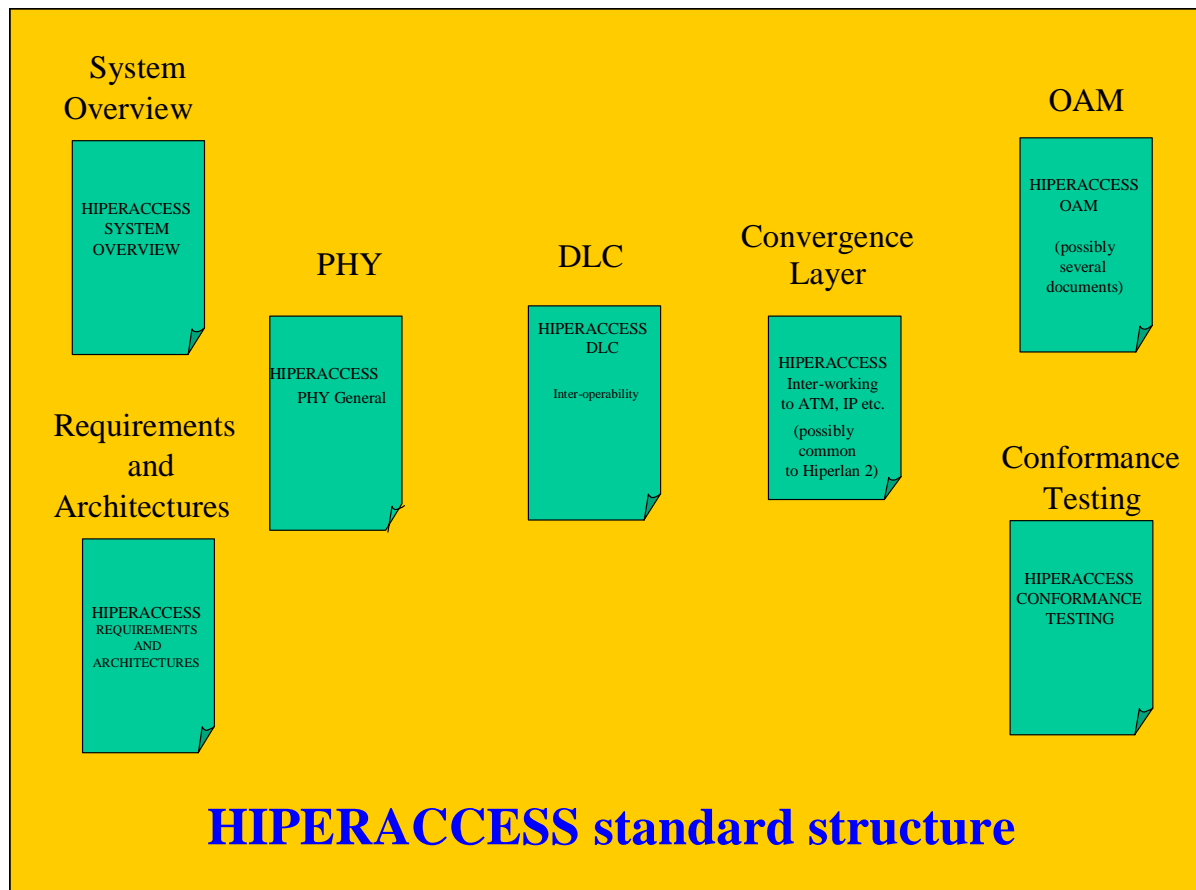


Figure 1: Standard document structure

### 4.1 General documents

The present document is the System Overview that together with the System Requirement document (see TR 101 177 [3]) gives the basic ideas about the system and the reasons behind choices within the technical specifications.

#### Physical layer (PHY)

A unique PHY layer is envisaged. The specification will define a fully interoperable PHY layer (see TS 101 999 [28]).

#### Data Link Control layer (DLC)

A unique DLC layer is envisaged. The specification will define a fully interoperable DLC layer (see TS 102 000 [29]).

#### Convergence layer (Access Termination)

The convergence layer (Interworking function) for mapping services over the DLC frame shall be defined for different services (for example IP and ATM). The reuse of HIPERLAN/2 specifications (or at least to keep within minimum differences) will be a goal to be pursued.

### Convergence layer (Access Point)

The convergence layer (Interworking function) for mapping services over the DLC frame shall be defined for different core networks (for example IP and ATM). The reuse of HIPERLAN/2 specifications (or at least to keep within minimum differences) will be a goal to be pursued.

### Operation and maintenance

For a full interoperability, operation and maintenance functions need to be specified.

### Conformance testing

Conformance testing specification are needed for interoperability.

## 5 Users, services and facilities

### 5.1 Who is HIPERACCESS for?

There is an increasing need for delivery of broadband digital communications services to individuals, households and businesses of all sizes. Whilst data rates supporting basic digitized voice services remain within the capability of existing wired networks, higher speeds are increasingly necessary. High speed Internet and Video are examples of service demanded by many users for a variety of business, household management and leisure activities. Users increasingly need a combination of voice and data, with a flexible allocation of data rates to suit their immediate needs. Data rates can vary considerably between different applications, traditionally being delivered by a mix of several communications technologies.

In response to these trends HIPERACCESS (HIgh PERFORMANCE Radio ACCESS) Systems are being specified for use by **residential customers** and by **small to medium sized enterprises (SMEs)** and **Mobile Infrastructure**. They will provide support for a wide range of voice and data services and facilities, using radio to connect the premises to other users and networks and offering "bandwidth on demand" to deliver the appropriate data rate needed for the service chosen at any one time.

**Table 1: Potential users, services and features for access**

User Requirement	User	HIPERACCESS Feature
Internet access	Residential/SME	Capacity and flexibility to support these services efficiently
Real time video	Residential/SME	Capacity and flexibility to support these services efficiently
Computer Gaming (downloading files and interactive sessions)	Residential	Capacity and flexibility to support these services efficiently
Video conferencing	Residential/SME	Capacity and flexibility to support these services efficiently
Video on demand/near VoD	Residential/SME	Capacity and flexibility to support these services efficiently
LAN access	Residential/SME	Capacity and flexibility to support these services efficiently
Multiple simultaneous users	Residential/SME	Bandwidth on demand and multiple service terminations (e.g. E1, n x 64 kbit/s)
Web Serving	SME	Capacity and flexibility to support these services efficiently
CES	SME	Capacity and flexibility to support these services efficiently
Homeworking	Residential	Capacity and flexibility to support these services efficiently
Support for legacy services	Residential/SME	Toll quality POTS and ISDN, fax. Voice band modems all to be supported

## 5.2 Traffic and service requirements

HIPERACCESS Systems are bearers for a wide diversity of applications. Not all applications need to be supported in all implementations of such systems. They may support a subset of the total set of possibilities, provided the services are supported in the specified manner. The data rate supported shall be variable on demand up to a peak of at least 25 Mbit/s in uplink and downlink directions delivered at the user network interface. It may be useful in some systems to allow only lower data rates to be supported, thereby decreasing the overall traffic requirement, which could reduce costs and lead to longer ranges.

The average user rate varies for different applications. Generally, the peak data rate for a single user is required only for short periods (high peak to mean ratio). The uplink and downlink user rates are not necessarily equal.

**Table 2: Average and Peak data rates for example services (during use of the services)**

Service	Average rate	Peak rate
Video telephony/conferencing	384 kbit/s to 2 Mbit/s	384 kbit/s to 2 Mbit/s
Video on demand (downlink only)	3 Mbit/s (typical)	6 Mbit/s
Computer gaming	10 kbit/s	25 Mbit/s
POTS	64 kbit/s	64 kbit/s
ISDN	144 kbit/s	144 kbit/s
Internet	10 kbit/s	25 Mbit/s
Remote LAN	10 kbit/s	25 Mbit/s
Compressed Voice	10 kbit/s	100 kbit/s

**Table 3: Average and Peak data rates for example market sectors (during use of the services)**

Application	Average rate	Peak rate
Low bit - rate voice codec	5,3 kbit/s [1]	32 kbit/s
POTS/ISDN	64 kbit/s	144 kbit/s
Residential internet/computer games/video entertainment	(see note)	2 Mbit/s to 25 Mbit/s
SME applications (POTS/ISDN/PRA/LAN interconnect/Internet)	(see note)	2 Mbit/s to 25 Mbit/s
Public safety/utility	(see note)	2 Mbit/s
Consumer electronic commerce	(see note)	2 Mbit/s to 8 Mbit/s
Education/medical	(see note)	2 Mbit/s to 25 Mbit/s
Telecommuting support	(see note)	2 Mbit/s to 25 Mbit/s
NOTE: Average rate is too variable to quantify.		

## 5.3 Performance issues

HIPERACCESS systems will behave, from the user perspective, like wired systems. The end users need not be aware that the services are delivered via radio. The performance in terms of access delays, bit error ratios, route set-up times and availability is to be comparable with the equivalent competing services. Quality of Service objectives are to be maintained making due allowance for adverse conditions of propagation, interference, equipment failure and increasing network load.

## 5.4 Comparison for HIPERACCESS

HIPERACCESS systems will compete with a variety of alternatives, some of which are already available and some of which are expected to become available over the next few years. These include:

- xDSL over copper pairs.
- Microwave Distribution Systems.
- DVB return channel systems.
- Cable TV.

- Cable modems.
- Optical fibre systems to homes and buildings.
- Electricity cables carrying additional services.
- Packet data radio.
- UMTS.
- Satellite systems.
- Stratospheric Platforms (high altitude platforms).

These competing alternatives deliver (or will deliver) various mixes of services and data rates to users. Some have bandwidth limitations and network costs vary considerably amongst alternatives.

One of the competitive strengths of HIPERACCESS systems over wired systems is the rapidity with which they can be deployed.

HIPERACCESS systems will compete by offering a high peak data rate to and from users, with dynamic "bandwidth on demand" to suit a wide range of applications, and be economical for mass-market applications. The ability to offer combinations of services, to take advantage of statistical multiplexing and, where sufficient spectrum is available, to support competing operators will all provide opportunities for competitive advantage of HIPERACCESS systems.

## 5.5 Application as UMTS backhaul

### 5.5.1 Rationale

HIPERACCESS due to its characteristics is a good and economical candidate as one of the technologies involved in the realization of UMTS backhaul.

The large bandwidth requirement and high base station concentration in micro and pico cells of UMTS deployment will require a large bandwidth interconnection system capable of collecting traffic from several "B nodes" very close to each other.

HIPERACCESS seems to be the natural way of doing this. The application as UMTS backhaul, not being properly an access function, is discussed separately in this clause but it is obvious that HIPERACCESS shall be able to support UMTS backhaul and end-user traffic with the same deployment possibly allowing statistical multiplexing of UMTS and end-user traffic sharing the same bandwidth.

### 5.5.2 Functional requirements

It has been found that the UMTS-Backhaul is a potential application candidate for HA system.

Indeed an efficient strategy to connect the UMTS RNC with different Node B with a HA-PMP architecture would be to consider a Dynamic bandwidth allocation (e.g. dynamic LL).

This strategy requires a deep analysis and consideration of the characteristics of the traffic within different UMTS-cells by performing a dynamic capacity allocation between RNC and different Node B.

Hence the following items might be considered in order to support UMTS applications as well:

#### **Signalling protocols (DLC):**

The Standardized UMTS interfaces are ATM based: E1/T1 ATM, E1/T1 IMA, E3/T3 ATM, STM-1 ATM. For small and medium Nodes B the most widely used interface will probably be E1/T1 IMA. Therefore, in order to support a dynamic bandwidth allocation between UMTS RNC and the HA-Access-Point, additional signalling protocols will be needed. The adaptation of these signalling protocols and their impacts on the HA-convergence-layer and the HA-DLC layers should be studied.

**Capacity Partitioning (DLC):**

In case of using the same carrier for UMTS Backhaul and other applications (e.g. residential, SOHO, SME, etc.) then an appropriate capacity partitioning mechanism is required to support the required capacity of UMTS Backhaul applications. This issue should be taken into consideration in CAC and in DLC scheduler.

**Guarantee of Capacity (PHY):**

UMTS applications may require for all HA terminals to guarantee the corresponding capacity all the time, independent of the weather conditions and independent of the location. This may require a deep study of the chosen strategy of adaptive coding and modulation for the downlink and the uplink as well.

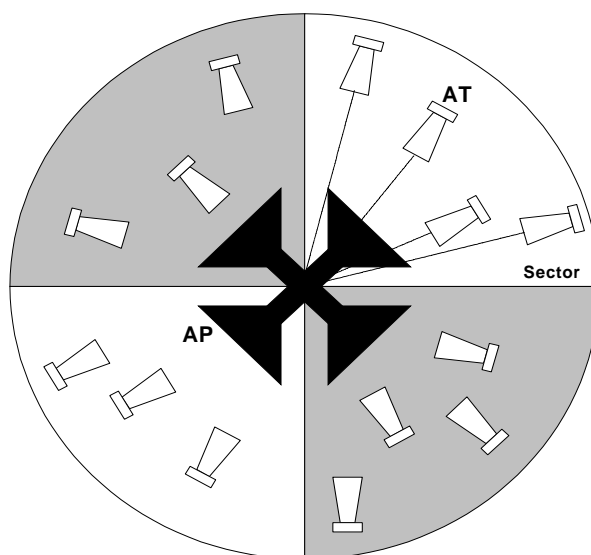
**Spectrum:**

If mixing different applications for the frequencies that are already identified for HA may not be allowed by the authorities, the alternative frequencies that are identified for UMTS-Backhaul applications should be further considered within HA-BRAN as well.

## 6 System features and architecture

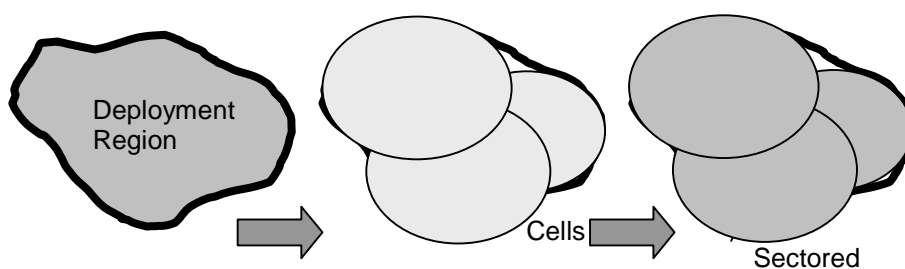
### 6.1 General

HIPERACCESS network deployments will potentially cover large areas (i.e. cities). Due to large capacity requirements of the network, millimetre wave spectrum will be used hence limiting transmission ranges to a few kilometres. A typical network will therefore consist of some number of **cells** each covering part of the designated deployment region. Each cell will operate in a **Point to MultiPoint (PMP)** manner, where an **Access Point (AP)** equipment device (also known as Base Station) located approximately at the cell centre, communicates with a number of **Access Termination (AT)** (maximum 254 per carrier and 256 per sector) devices (also known as Terminal or Subscriber Equipment) which are spread within the cell.



**Figure 2: Example of cellular configuration (4 x 90° sectors)**

A cell is partitioned into a small number of **Sectors** (i.e. 4) by using sector azimuth patterned antennas at the AP, increasing spectrum efficiency by the possibility of re-using available RF channels in a systematic manner within the deployment region. It is emphasized that more than one subscriber within the sector may share a RF channel assigned to a specific sector - meaning that the ratio between AT equipment count and AP equipment count is typically a large number. This is in contrast to **Point-to-Point (PtP)** architectures where the sharing of the radio link among many subscribers is impossible. Sharing of the link leads to increased spectrum efficiency due to statistical multiplex capacity gain hence PMP is the superior choice for HIPERACCESS.



**Figure 3: Cellular deployment**

As Line of Sight (LoS) conditions are essential for millimetre wave communications, cells may overlap in their coverage patterns. The overlap increases the likelihood of LoS conditions hence allowing for better market penetration.

#### Duplex Schemes (FDD, TDD and H-FDD)

As the communication channel between the AP and ATs is bi-directional, **Downlink** (AP to AT direction) and **Uplink** (AT to AP direction) paths must be established utilizing the spectrum resource available to the operator. Two duplex schemes are available, one is frequency domain based and one is time domain based.

Frequency Division Duplex (FDD) partitions the available spectrum into a downlink block and an uplink block. A RF channel is actually a pair of channels, one from the downlink block and one from the uplink block, hence downlink and uplink transmissions are established on separate and independent radio channels. In HIPERACCESS both downlink and uplink channels are equal in size, 28 MHz wide.

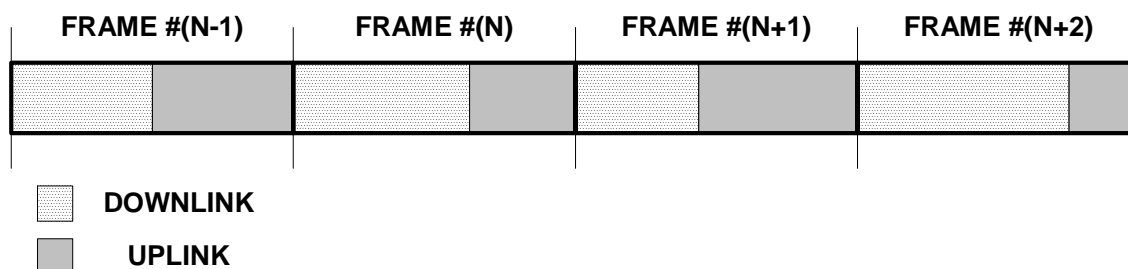
In the half duplex FDD (H-FDD) case, if AT radio equipment is limited to a half-duplex operation (i.e. transmission and reception cannot occur instantaneously) then relaxation of some design parameters is possible (i.e. isolation) hence AT cost reduction is facilitated. The DLC layer acknowledging AT limitations must schedule downlink reception events and uplink transmission events accordingly. Furthermore the AP recognizes in this case the fact that switching from transmission operation to reception operation (and vice versa) at the AT is not immediate (i.e. ramp up of power output).

It is emphasized that the half-duplex operation is an AT feature only. The AP has a different impact on the deployment cost and on system capacity (if half-duplex operation is employed at the AP). Note that in addition to AT burst transmission capability half-duplex operation requires burst reception capability as well.

In HIPERACCESS, half-duplex operation in the AT equipment is an optional feature. However AP equipment shall support AT equipment, which has implemented this feature.

In contrast to FDD, Time Division Duplex (TDD) uses the same RF channel for downlink and uplink communications. The downlink and uplink transmissions are established by time-sharing the radio channel where downlink and uplink transmission events never overlap. In HIPERACCESS the channel size is 28 MHz wide as in the FDD case.

In HIPERACCESS, the AP establishes a frame based transmission and allocates portion of its frame for downlink purposes and the remainder of the frame for uplink purposes. The ratio between the allocated time for downlink transmissions and the time allocated for uplink transmissions is configurable.



**Figure 4: TDD framing**

Note that in general the HIPERACCESS TDD standard is based completely on the HIPERACCESS FDD standard.

## PHY modes: modulation and coding schemes

Typically when a carrier is shared by more than one AT, modulation and coding parameters are set according to the AT which has the greatest path loss or is exposed to the greatest amount of interference. Coupled with the fact that the operator wishes to maximize coverage, the modulation and coding choice in these cases will be robust yet spectrum inefficient (i.e. QPSK with a low rate code).

Even if the cell size is greatly reduced, potentially allowing for higher order modulation schemes (i.e. 64QAM) to be used, the self-interference conditions (due to the multi-cell deployment) will dominate and prevent service to some large number of ATs (i.e. coverage dead spots).

HIPERACCESS uses adaptive PHY modes for solving this problem. A PHY mode is a predefined combination of modulation and coding parameters. In contrast with legacy transmission systems where one PHY mode dominated the entire downlink transmission, in the HIPERACCESS case more than one PHY mode is used occupying different parts of the downlink frame. In the uplink different ATs use different PHY modes according to their individual link conditions.

The AP controls the use of a specific PHY mode. If for example link conditions deteriorate (i.e. rain) then it is expected that more ATs will be assigned to more robust PHY modes. If the link recovers then it is expected that more ATs will be assigned to more spectrum efficient PHY modes within their link limitations. Although in some deployment scenarios uplink transmissions can employ similar techniques to those of the downlink, there will be some cases where it will be useful to limit the choices of PHY modes for the uplink due to a different, random-like, interference behaviour especially apparent when the available spectrum is re-used aggressively.

In HIPERACCESS, the modulation format will be QAM based. The forward error correction scheme will be based on a Reed Solomon code concatenated with a convolutional code. Only some of the PHY modes include the concatenation process, which in any case has no interleaving.

## Multiplexing Technique and Frame Structures

As more than one AT is sharing the same RF channel, the AP must employ techniques controlling the access of ATs. In the case of HIPERACCESS, TDMA (Time Division Multiple Access) shall be used. After an AT has been registered with the system, its uplink bursts are scheduled by the AP. Scheduled events are basically time coordinates which uniquely define when the AT shall begin and end its transmission. The schedule data for uplink transmission is organized in an Uplink Map broadcasted by the downlink.

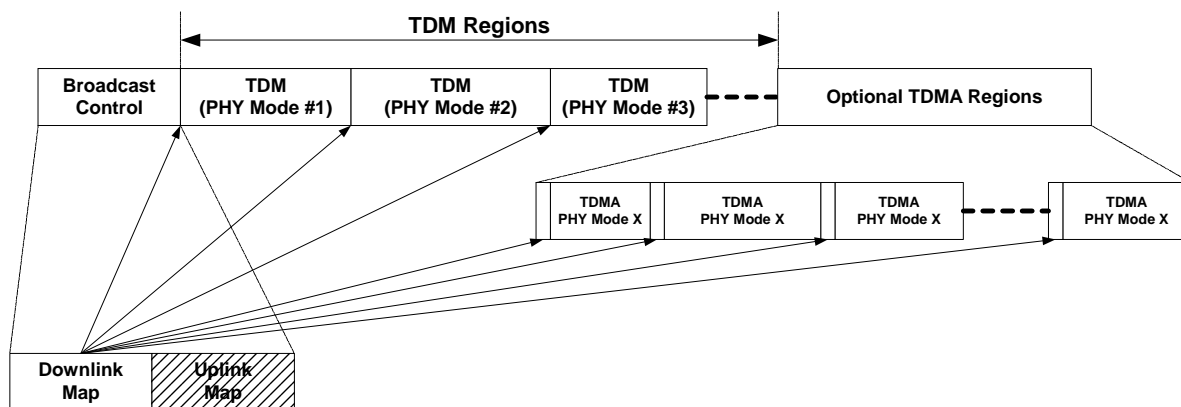
An AT can transmit in an unsolicited, contention based, manner only in the following 2 cases:

- For registration purposes.
- For responding to multicast or broadcast polls (for bandwidth needs).

The downlink data of different ATs is multiplexed in the time domain (TDM). As HIPERACCESS employs adaptive PHY modes, a frame consists of a few TDM regions. Each TDM region is assigned with a specific PHY mode. Only ATs capable of receiving (i.e. demodulating) the assigned PHY mode may find their downlink data multiplexed in the associated TDM region. To simplify the demodulation process, TDM regions are allocated in a robustness descending order. For example, an AT with excellent link conditions, which is assigned to a spectrum efficient PHY mode, starts its reception process at the beginning of the frame and continues through all TDM regions (using a more robust PHY mode) ending its reception process with its associated TDM region. An AT with worse link conditions will be assigned to a more robust PHY mode and its reception process will end before the AT of the previous example. Note that in any case all synchronization related operation is performed once per frame for all ATs.

The TDM region location within a frame is broadcasted in a downlink map, similarly to the uplink map, at the beginning of the frame.

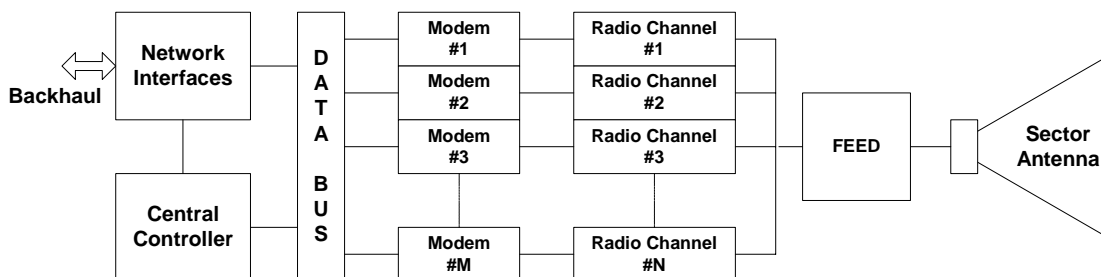




**Figure 5: Downlink framing and multiplexing**

TDMA transmissions are optionally present on the downlink. In this scheme, an AT may be assigned to receive downlink transmissions either in a TDM region as previously discussed or in a detached TDMA region. The TDMA region allocations are broadcast as part of the downlink map. With no downlink TDMA option, a half-duplex AT has limited opportunities to transmit as it is forced to demodulate the downlink continuously from the beginning of the downlink frame and once it transmits it must wait for the next downlink frame to re-synchronize. With the downlink TDMA option the AT may seek downlink reception opportunities immediately after it ceased its uplink transmission within the current downlink frame. The AP scheduling procedures should use the downlink TDMA feature as it increases channel utilization and minimizes latencies. Note that a TDMA region may serve more than one AT by time division multiplexing downlink data of several ATs.

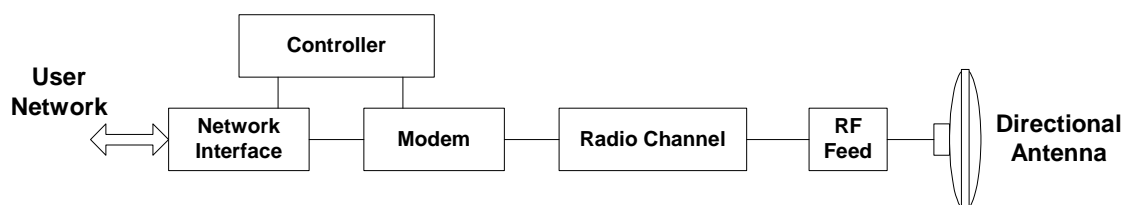
AP block structure



**Figure 6: AP block diagram**

The AP typically manages communications of more than one sector. For each sector one antenna or more is positioned to cover the deployment region. A feeding structure may connect the radio transceivers to the antenna. Each radio transceiver communicates with a modem logically including PHY and DLC functions. Data being sent to or received from the modem is conveyed over data bus means. A central controller, communicates and controls the modems and network interfacing blocks which transport the cell data as backhaul to the main network.

AT block structure



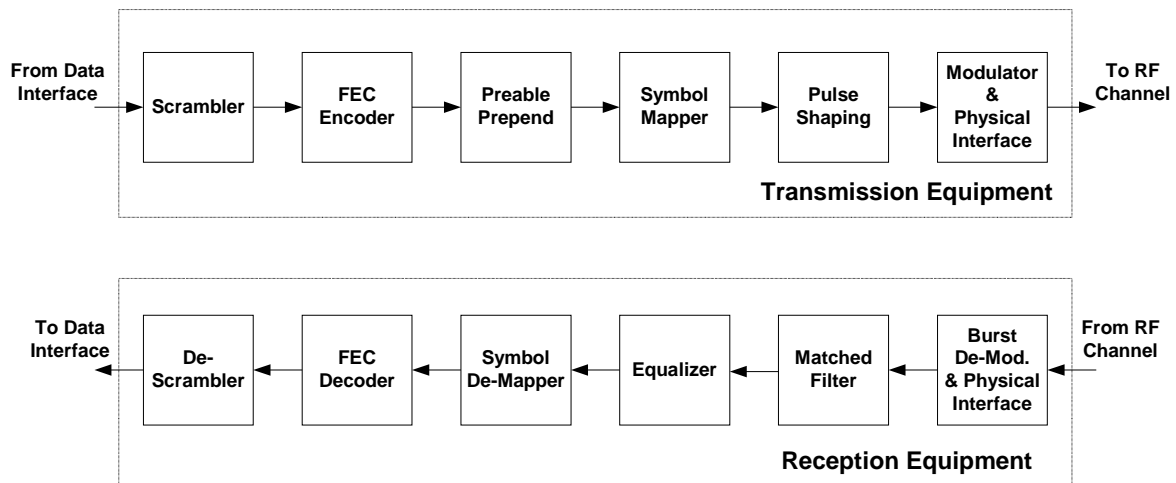
**Figure 7: AT block diagram**

The AT antenna is directional, pointed to the serving AP. A feeding structure connects between the radio transceiver and the antenna. The radio transceiver communicates with a modem logically including PHY and DLC functions. Data is being sent to or received from the modem to the network interface. The network interface connects with the local user network (i.e. LAN, TDM).

## 6.2 Physical (PHY) layer

The architecture of the PHY-layer is determined mainly by the following HA-features:

- Single carrier transmission.
- Support of different duplex schemes: FDD, H-FDD and TDD.
- Use of adaptive coding and modulation.



**Figure 8: PHY-layer conceptual block diagram**

A PHY implementation includes transmission equipment and reception equipment. For the downlink, transmission occurs in the AP and reception in the AT. For the uplink, transmission occurs in the AT and reception in the AP. Although very similar in concept, note that the AP equipment in general handles more than one RF channel and more than one user (AT) hence its actual architecture will be different. Further note that the description in this clause is conceptual only and implementers are free to combine different functional entities or split other blocks as they choose as some of the blocks and their specific connectivity to other blocks are not mandated by the standard (i.e. equalizer).

Transmission operation from the PHY perspective starts with a stream of data sent from higher layers (i.e. DLC). This data is initially randomized using a scrambler. In HIPERACCESS the coding and modulation are separated hence first the data is protected by FEC encoding. The preamble data (in the downlink case this exists only in the beginning of the frame or in the beginning of each TDMA region) is prepended. The resulting data is then mapped into symbols according to the designated modulation density. The resulting symbols are pulse shaped (i.e. root raised cosine filter) and are prepared through a physical interface (i.e. D/A) for the radio transmitter.

Reception operation from the PHY perspective starts with receiving an analogue signal from the radio receiver. This could be a base band (i.e. Zero-IF) signal or some low IF frequency. The physical interface (i.e. A/D) converts the signal to the digital domain and a burst demodulator identifies the preamble existence and the reception process may properly initiate. A matched filter is used to extract symbol values and an equalizer structure can be used to further enhance signal quality. Symbols are translated to actual bits by constellation de-mapping. A FEC decoder corrects data errors any may be used to identify data integrity. Any randomization done by the scrambler in the transmission process is removed and data is sent to the higher layers for continued processing.

### Modulation

The modulation shall be based on Quadrature Amplitude Modulation with  $2^M$  points constellation, where M is the number of bits transmitted per modulated symbols.

For the downlink QPSK ( $M = 2$ ) and 16QAM ( $M = 4$ ) are mandatory and 64QAM ( $M = 6$ ) optional. For the uplink QPSK is mandatory and 16QAM optional. The constellation mappings shall be based on Gray mapping.

## PHY modes

PHY mode includes modulation and a coding scheme (FEC). Several sets of PHY-modes are specified for the downlink. The reason for specifying different sets of PHY-modes (each having different SNR gap) is to offer a higher flexibility for the HA-standard deployment, where the adequate choice of a given set of PHY-modes will be determined by the deployment scenario: coverage, interference, rain zone, etc.

The coding scheme is based on a outer Reed Solomon with  $t = 8$  and a payload length of 4 PDUs shortenable to 3, 2 or 1; the shortening is required to avoid padding at the end of the PHY mode section (called "Region"). An inner convolutional code is specified in some of the PHY modes.

Table 4: DL-PHY-modes characteristics

Set of Downlink PHY-Modes	Inner code	Outer code (K = 1 to 4 PDUs)	Modulation	Expected SNR in dB (with 4 PDUs per RS)	
				@10 <sup>-6</sup>	@10 <sup>-11</sup>
<b>Set-1 (mandatory)</b>				@10 <sup>-6</sup>	@10 <sup>-11</sup>
<b>M1</b>	CC2/3	RS (K, K + 16, t = 8)	QPSK	6	7
<b>M2</b>	no	RS (K, K + 16, t = 8)	QPSK	10	11
<b>M3</b>	CC7/8	RS (K, K + 16, t = 8)	16QAM	15	16
<b>M4 (optional)</b>	CC5/6	RS (K, K + 16, t = 8)	64QAM	21	22
<b>Set-2 (optional)</b>				@10 <sup>-6</sup>	@10 <sup>-11</sup>
<b>M1</b>	CC2/3	RS (K, K + 16, t = 8)	QPSK	6	7
<b>M2</b>	no	RS (K, K + 16, t = 8)	QPSK	10	11
<b>O3</b>	no	RS (K, K + 16, t = 8)	16QAM	17	18
<b>O4 (optional)</b>	no	RS (K, K + 16, t = 8)	64QAM	23	25

Uplink PHY modes are a subset of downlink PHY modes in each set.

Table 5: UL-PHY-modes characteristics

Set of Downlink PHY-Modes	Inner code	Outer code (K = 1 to 4 PDUs)	Modulation	Expected SNR in dB (with 2 PDUs per RS)	
				@10 <sup>-6</sup>	@10 <sup>-11</sup>
<b>Set-1 (mandatory)</b>				@10 <sup>-6</sup>	@10 <sup>-11</sup>
<b>M1</b>	CC2/3	RS (K, K + 16, t = 8)	QPSK	6	7
<b>M2</b>	no	RS (K, K + 16, t = 8)	QPSK	10	11
<b>M3 (optional)</b>	CC7/8	RS (K, K + 16, t = 8)	16QAM	15	16
<b>Set-2 (optional)</b>				@10 <sup>-6</sup>	@10 <sup>-11</sup>
<b>M1</b>	CC2/3	RS (K, K + 16, t = 8)	QPSK	6	7
<b>M2</b>	no	RS (K, K + 16, t = 8)	QPSK	10	11
<b>O3 (optional)</b>	no	RS (K, K + 16, t = 8)	16QAM	17	18

## 6.3 DLC

The essential features of HIPERACCESS DLC are:

- efficient use of the radio spectrum;
- high multiplex gain;
- maintaining QoS.

Multiplexing means that  $m$  subscribers can share  $n$  radio channels ( $m$  being larger than  $n$ ), allowing a better use to be made of the available frequency spectrum and at a lower equipment cost. The term "multi-access" derives from the fact that every subscriber has access to every channel (instead of a fixed assignment as in most multiplex systems). When a call or service is initiated the required resource is allocated to it. When the call or service is terminated, the resource is released. Concentration requires the use of distributed intelligent control which in turn allows many other operations and maintenance functions to be added.

Maintenance of QoS means that the exchange (service node) and the subscriber equipment can communicate with each other without being restricted by the actual quality of the radio link.

As more than one AT is sharing the same UL carrier, the AP must employ techniques controlling the access of ATs. For HIPERACCESS, only TDMA (Time Division Multiple Access) shall be used. After an AT has been initialized with the system, its UL transmission events are scheduled by the AP. Scheduled events are basically time coordinates which uniquely define when the AT shall begin and end its transmission. The schedule data for UL transmission is organized in an UL map which is broadcasted in the DL.

An AT can transmit in an unsolicited, contention based, manner only in the following cases:

- For initialization purposes.
- For bandwidth requests.

The DL data stream to different ATs is multiplexed in the time domain (TDM). As HIPERACCESS employs adaptive PHY modes, a frame consists of a few TDM regions. Each TDM region is assigned with a specific PHY mode. Only ATs capable of receiving (i.e. demodulating) the assigned PHY mode may find their DL data multiplexed in the associated TDM region. For simplifying the demodulation process, TDM regions are allocated in a robustness descending order. For example, an AT with excellent link conditions, which is assigned to a spectrum efficient PHY mode, starts its reception process at the beginning of the frame and continues through all TDM regions (using a more robust PHY mode) ending its reception process with its associated TDM region. An AT with worse link conditions will be assigned to a more robust PHY mode and its reception process will end before the AT of the previous example. Note that in any case all synchronization related operation is performed once per frame for all ATs.

The TDM region location within a frame is broadcasted at the beginning of a DL frame in the DL map, together with the UL map, used instead to give grants to different ATs. Both DL and UL maps together with some other information fields are referred to as the control zone at the beginning of the frame.

TDMA transmissions could be optionally present in a TDMA zone on the DL in addition to the DL TDM zone. In this scheme, an AT may be assigned to receive DL transmissions either in a TDM region as previously discussed or in a TDMA region. The TDMA region allocations are broadcasted as part of the DL map. With no DL TDMA zone, a half-duplex AT has limited opportunities to transmit as it is forced to demodulate the DL continuously from the beginning of the DL frame and once it transmits it must wait for the next DL frame to re-synchronize. With the DL TDMA option the AT may seek DL reception opportunities immediately after it ceased its UL transmission within the current DL frame. The AP scheduling procedures should use the DL TDMA feature as it increases channel utilization and minimizes latencies. Note that a TDMA region may serve more than one AT by time division multiplexing DL data of several ATs.

The DLC layer is connection oriented (this means that MAC PDUs are received in the same order as sent and that a connection is set up before MAC PDUs are sent) to guarantee QoS. Connections are set up over the air during the initialization of an AT, and additionally new connections may be established when new services are required.

Both ATM and IP are supported efficiently by means of a fixed MAC PDU size.

The RLC sublayer contains radio resource control in particular, initialization control and connection control (on DLC level).

- Radio resource control: This includes all mechanisms for load levelling, power levelling and change of PHY modes. These functions are radio link-specific and thus AT-specific.
- Initialization control: This includes all mechanisms for the initial access and release of a terminal to/from the network as well as the re-initialization process required in case of link interruptions or PSI. These functions are AT-specific.
- DLC connection control: This includes all mechanisms for the setup and release of connections (connection admission control, CAC) and connection aggregates, and in particular a tabular linking connection aggregates, their QoS requirements and the appropriate request grant mechanisms together. These functions are of course connection-specific.

The adaptive operation of modulation and coding is able to counteract the slow propagation behaviour in case of rain fading but is powerless against the fast behaviour of the uplink interference.

Indeed while the *C/I* (carrier-to-interference power ratio) in the DL can be deterministically evaluated and effectively counteracted by FEC mechanism at the PHY layer, the interference in the UL direction is time-variant, as it depends on the location and the number of the simultaneous interfering ATs from other cells or sectors. The time-variant *C/I* behaviour in the UL can cause unacceptable service unavailability when exceeding the FEC capability. The higher the "PHY mode" throughput, the higher is the related unavailable time. Therefore the UL PHY modes with higher code rates or higher-level modulation schemes are more effectively usable if particular mechanisms like ARQ are applicable.

The ARQ protocol is implemented at the DLC level, where the error detection is performed in the PHY layer. It is based on a selective-repeat approach, where only the PDUs carried by erroneously received RS codewords are to be re-transmitted. The impact of ARQ is as follows:

- in terms of delay, the support of ARQ in the UL direction implies the introduction of a fixed delay for all data to be re-transmitted from the AT to the AP and thus a delay for the whole data stream for the respective connection/AT. So ARQ is only applicable for those services for which this additional delay is tolerable.

The ARQ mechanism is based on a selective-repeat approach, where only the PDUs carried by erroneously received RS codewords are to be re-transmitted. In the AP, the received RS codewords are checked and in case of detected errors the RS codeword itself and all PDUs carried by this codeword are discarded. If at least one erroneous RS codeword in an UL frame is detected, then the AP will set an indication in the control zone of the next DL frame, enforcing a re-transmission procedure for all PDUs of those ATs which have at least one connection with ARQ.

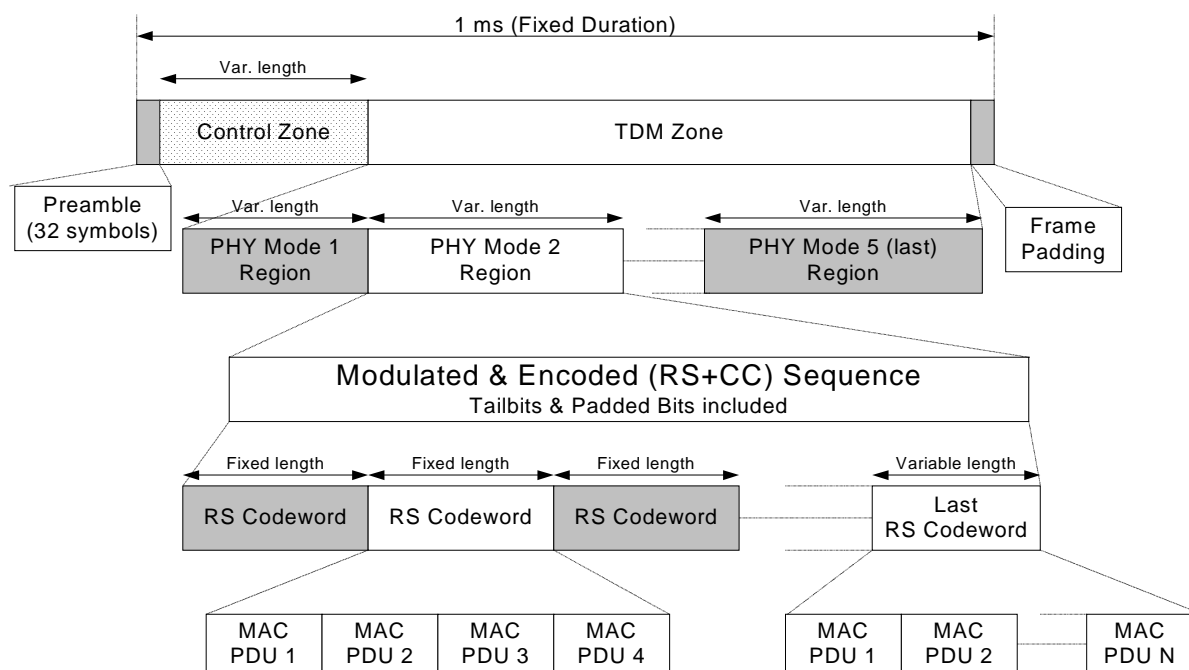
Some important key features of the MAC sublayer are

- Requests are per connection or per connection aggregate.
- Grants are given per terminal.
- Connections are grouped into connection aggregates.
- Several request-grant mechanisms are supported.
- ARQ is supported.

The most important security requirements are as follows:

- Protection of traffic privacy.
- Fraud prevention.
- Checks for legitimate use.
- Medium security level.

The mapping of MAC PDUs to the PHY structure for the DL direction is shown in figure 9.



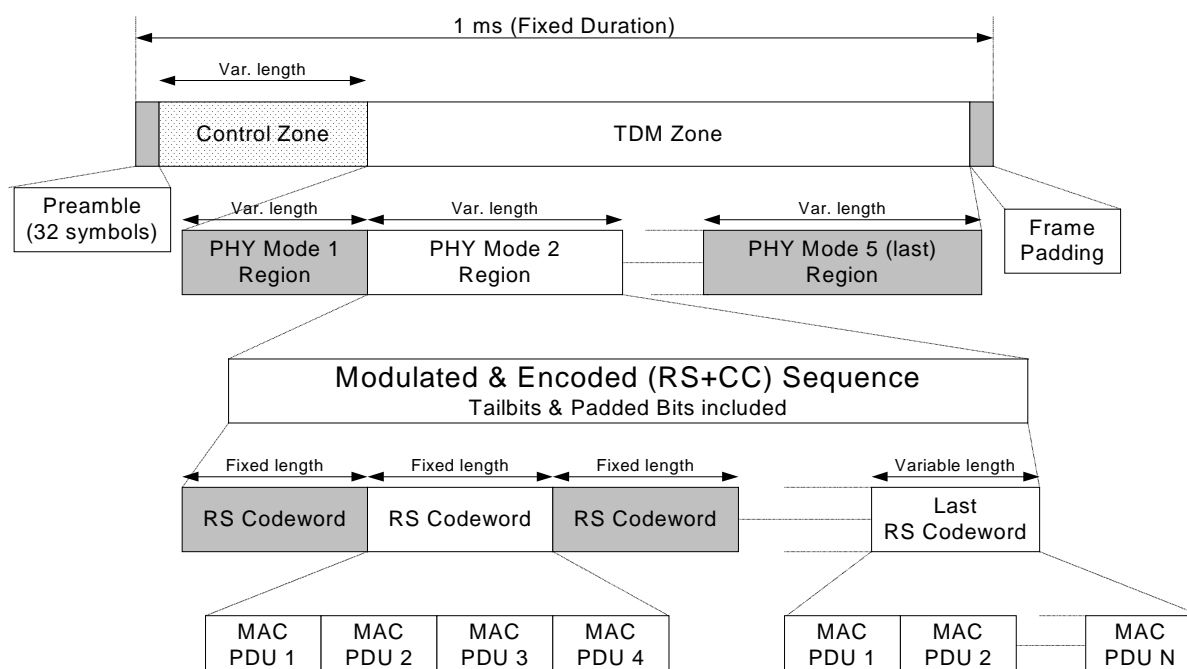
NOTE:  $N \leq 4$ .

**Figure 9: Transmission of MAC PDUs in DL without TDMA option**

The frame starts with a preamble of 32 symbols. A control zone follows the preamble containing the DL and UL maps. The maps indicate events (i.e., PHY modes as well as location and duration within a frame). The DL map defines the TDM zone and optionally a TDMA zone. The UL map defines signalling events and different kinds of windows and specific user transmission events.

A TDM zone consists of different PHY mode regions by descending robustness order (i.e., QPSK precedes 16QAM). Each PHY mode region time multiplexes data associated with different ATs capable of demodulating and decoding the associated PHY mode. As the number of addressed ATs within a PHY mode varies and such does their instantaneous DL data rate, all PHY mode region durations can vary from frame to frame.

Each PHY mode consists of data which was concatenated (by an outer RS block code and, for some PHY modes, an inner convolutional code) encoded using a RS codeword encapsulating four MAC PDUs, except the last RS codeword where shortening is applied if the remaining number of PDUs per RS codeword is less than four. In case of an inner convolutional code, trellis terminating bits are added to each RS codeword, so an FEC block corresponds to an RS codeword. The number of symbols required for the transmission of a PHY mode region depends on the modulation scheme. At the end of a PHY mode region, padding bits are added to complete a modulation symbol. To fill up the TDM zone, MAC dummy PDUs are inserted (in arbitrary PHY mode regions of the TDM or TDMA zone) and additional padding symbols are added at the end of the TDM zone to complete exactly the frame (in case of no optional TDMA zone).



NOTE:  $N \leq 4$ .

**Figure 10: Transmission of MAC PDUs in DL with TDMA option**

Figure 10 shows the mapping of MAC PDUs to the frame structure in the DL in case of the additional TDMA zone. Optionally, a TDMA zone follows the TDM zone. Similar to the TDM zone, the TDMA zone consists of different PHY mode regions (bursts) with the following differences:

- No specific robustness order will be applied.
- Each PHY mode region starts with a short preamble of 16 symbols.

Note that the TDMA zone is intended to be used by H-FDD ATs. The H-FDD AT is expected to demodulate and decode the beginning of the frame containing the control zone. Depending on its recent UL transmission event, it is expected that the H-FDD AT will switch back to DL reception and recover its data in a TDMA PHY mode region suitable for its link conditions.

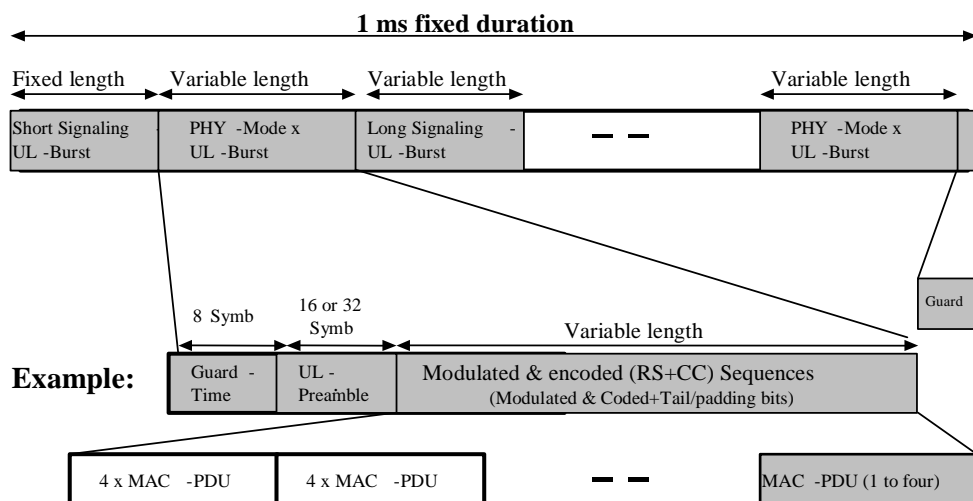
The PHY mode region shall be composed of one or more FEC blocks. Every FEC block shall contain 4 MAC PDUs, only the last FEC block in a PHY burst shall contain a number of MAC PDUs equal to 1, 2, 3 or 4 in order to complete the transmission of the number of MAC PDUs foreseen for the burst. The number of symbols within each FEC block depends on the relevant PHY mode. The total length of a burst shall be an integer number of symbols, the last symbol shall be padded with bit values equal to 0 as necessary.

The UL frame is subdivided in:

- several windows for contention-based access (i.e, non-scheduled or multicast-invited transmissions, applies only for short MAC signalling PDUs); and
- scheduled bursts (i.e, invited traffic from AT, applies for MAC data PDUs, long MAC signalling PDU as well as short MAC signalling PDUs),

where the locations of these different parts within an UL frame are indicated by the UIUCs in the UL map which is broadcasted in the control zone in the DL at the beginning of each frame. See clause 8.2.2 for more details on the UL frame structure.

In figure 11, only the mapping of MAC PDUs to the PHY structure is shown for the UL direction, where no fragmentation of UL bursts or fragmentation of UL MAC PDUs is assumed.



**Figure 11: Transmission of MAC PDUs in UL**

Note that all UL bursts will be preceded by a guard time and a preamble.

An AT, which the UL map has indicated the existence of an UL transmission event for it, is expected to transmit its data at the indicated time which provisions sufficient time for AT transmitter ramp-up. The PHY mode used by the AT for the transmission is specified as well by the UL map. The AT begins its transmission with a preamble with length of 16 or 32 symbols, depending on the AP capability that will be negotiated during the initialization phase.

An AT transmission may include more than one MAC PDU, and as similar to the DL, MAC PDUs shall be encapsulated into a RS codewords of fixed length. The last RS codeword will be shortened in the case where the number of remaining MAC PDUs is less than four.

As the AT finishes to transmit its data, it may ramp-down its transmitter. This period of time is expected to overlap a ramp-up period of the next AT scheduled for transmission.

There are some differences for the TDD mode compared to the FDD mode:

Differences in downlink:

- No TDMA zone is required, as inherently all ATs are H-FDD operated and no special handling is required.
- The actual DL frame length is less than 1 ms as only a portion of the full frame is allocated for DL means. The split between DL and UL is effectively stated by the DL and UL map. The UL transmission starting symbols within a frame are determined by the UL map.
- At the end of the TDD DL frame a Tx/Rx-switching time of 48 channel symbols corresponding to about 2  $\mu$ s is required for switching from reception to transmission of the AT.

Differences in uplink:

- The actual UL frame length is less than 1 ms as only a portion of the full frame is allocated for UL means.
- At the end of the TDD UL frame a Tx/Rx-switching time of 48 channel symbols corresponding to about 2  $\mu$ s is required for switching from transmission to reception of the AT.

This clause is structured as follows:

- MAC PDU formats; especially the MAC PDU headers for DL and UL directions, for MAC data PDU, MAC dummy PDU, long and short MAC signalling PDU.
- Frame Structure for DL and UL directions.
- Support of FDD and TDD mode and H-FDD operation.
- Structure of maps for DL and UL



- Support of ARQ (operation of ARQ, frame structure and map for ARQ)
- Detailed structure of the control zone
- MAC Support of PHY layer (time relevance of the maps, map protection, PHY mode set description)

The mapping of the MAC PDUs to the PHY structure (i.e, to codewords, PHY mode regions and zones) is described in clause 5.3 about the interface between DLC- and PHY layers.

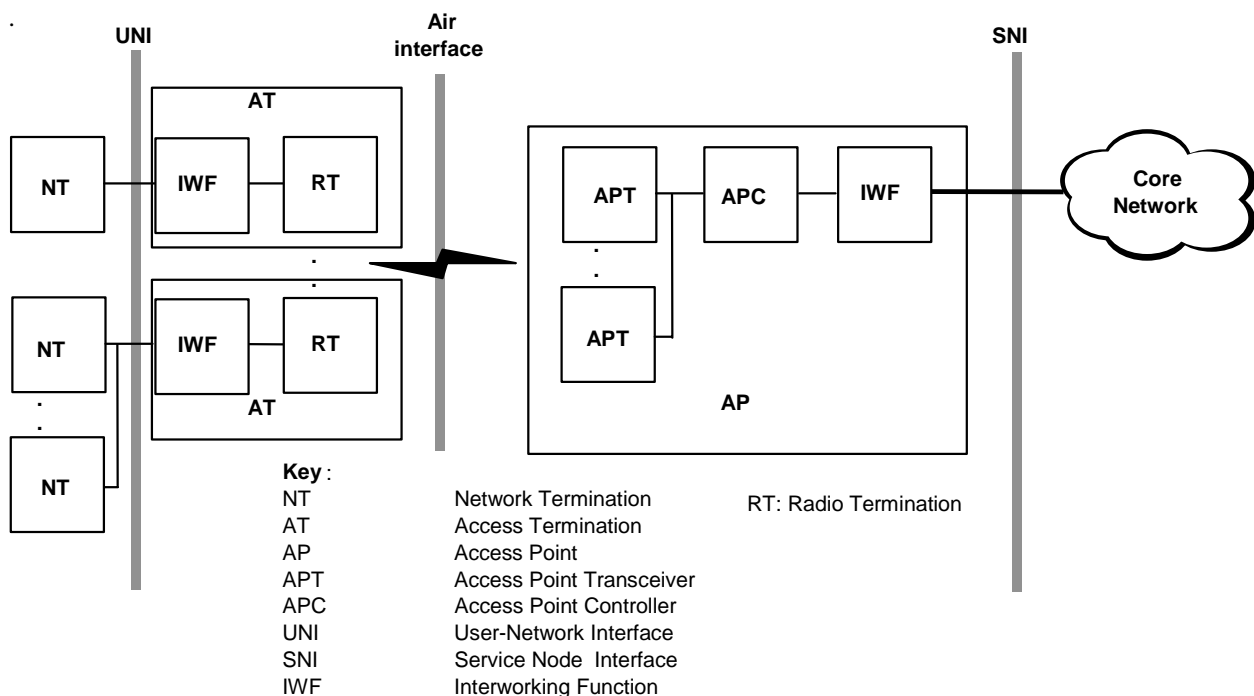
## 7 Network aspects

This clause describes the general configuration of HIPERACCESS networks, their interfaces with core networks and with terminals.

### 7.1 System configurations

Figure 12 shows the basic system arrangement, in which user terminal equipment connects via interface W.3 with an Access Termination (AT). User terminals may support one or more of a range of user services, according to the particular system specification. A system will normally deploy many Access Terminations. ATs communicate with the rest of the network over the Air Interface (W.1).

Connection to local (core) networks occurs at Access Points (APs), comprising APTs (Access Point Transceivers), APCs (Access Point Controllers) and IWFs (InterWorking Functions). The interface is point W.2, where connection to one or more networks such as ATM, IP, UMTS occurs.



**Figure 12: Basic arrangement of HIPERACCESS network**

## 7.2 Interfaces

The main interfaces of HIPERACCESS systems are shown in tables 6 and 7. Some external interfaces (such as W.2 and W.3) are defined in the system but are specified by other bodies.

**Table 6: Interfaces description**

Reference	Interface Points	Description
W.1	Access Termination-Radio Relay Access Termination-Access Point Access Termination/Radio Relay-Access Point Access Termination/Radio Relay-Radio Relay	Internal air interface
W.3	User terminal - Access Termination	External interface to user application/terminal (e.g. ATM, ISDN(U))
W.2	Access Point-Local (core) network	External interface to local/core network (e.g. ATM, VB5)
B.3	Access Point-Management System (EMS)	External interface to Element Management System

**Table 7: Baseband interface**

UNI (W.3)	SNI (W.2)
Ethernet 10BaseT	VB5.1
ATMF25,6	VB5.2
E1 (fractional/not fractional)	V5.1
E1 ATM (G.804 [30])	V5.2
ISDN BRA/PRA (I.430 [31], I.431 [32])	155 ATM NNI/UNI
POTS	
ATMF 25M	

The air interface will be specified in terms of Inter-operability aspects. HIPERACCESS systems will meet Inter-operability requirements.

## 7.3 Other interfaces

Apart from the air interface and the main external interfaces, other interfaces exist within HIPERACCESS networks. Internal interfaces between components of Access Terminations and between components of Access Points are specified at the logical level only. The actual implementation can vary from system to system.

## 7.4 Security aspects

HIPERACCESS systems are intended to form part of wider overall networks. The existence of a radio access part means that systems may be subject to attempted interception of the over-the-air signals. Security features will be needed in the end to end network as follows:

- Prevention of unauthorized eavesdropping.
- Support for Legal Interception.
- Adaptable to meet export regulations (e.g. by disabling or modifying encryption algorithms).
- Preventing the use of stolen or cloned network components.
- Check for "legal" connection of Access Terminations.
- Periodic checks for validity of Access Terminations.

Security requirements and specification of security functions is part of the DLC specification.

## 7.5 Network performance

When HIPERACCESS system is used onto a access network based on ATM, the broadband radio systems should also be ATM based. In order to guarantee the Service Level Agreement requirements for services provided over ATM, the requirements defined by ITU-T Recommendations listed in table 8 should be satisfied.

**Table 8: List of relevant ITU-T Recommendations**

Recommendation	Focus
ITU-T Recommendation I.356 [16]	Parameters for ATM cell transfer performance QoS classes
ITU-T Recommendation I.361 [17]	ATM cell structure ATM service primitives GFC class
ITU-T Recommendation I.363 [18]	ATM adaptation layer (AAL) requirements
ITU-T Recommendation I.371 [19]	Functions and parameters for traffic and congestion control

## 7.6 ATM requirements

### 7.6.1 Traffic control requirements

HIPERACCESS system should be able to handle the different ATM transfer capabilities defined in ITU-T Recommendation I.371 [19] (also referred to by the acronyms CBR, VBR, ABR and UBR) and related to the classes of QoS defined in ITU-T Recommendation I.356 [16].

In order to be in a position to assess the traffic priorities, the HIPERACCESS system should therefore ensure the functions of UPC/NPC (Usage Parameter Control/Network Parameter Control) defined in ITU-T Recommendation I.371 [19] based on:

- the cell loss priority (CLP) bit: the UPC/NPC functions may discard, tag or pass the cells according the traffic contract and the value of the CLP bit;
- the explicit forward congestion indication (EFICI) in order to induce a decrease of the cell rate at the customer equipment.

For the need of the system management, the recording of some ATM statistics is useful. This information should be in compliance with the recommendation included in EN 301 163-1-1 [20], clause 11.1.4.

## 7.7 Network management

The network element management requirements by functional category can be defined by five categories, according to ITU-T Recommendation M.3010 [21]. These are:

- Configuration Management.
- Performance Management.
- Fault Management.
- Security Management.
- Accounting Management.

The functions required to operate and maintain the physical layer and ATM layer aspects of the B-ISDN for permanent, semi-permanent, reserved and on-demand virtual connections are defined by ITU-T Recommendation I.610 [22]. Maintenance of the ATM layer at segment or end-to-end levels covering VP and VC respectively is implemented by means of dedicated OAM cells. ITU-T Recommendation I.610 [22] specifies the purpose and the realization (using different OAM cell types) of the following functions:

- Fault management, using AIS, RDI, CC and LB cells.

- Performance management, using FPM and BR cells.
- Activation/deactivation of PM and/or CC, using activation/deactivation cells.
- System management cells for use by end-systems only.

The management information flows through the Q3 interface. In order to reduce the cost of terminal equipment, however, a minimum set of OAM functions may be supported. The definition of this reduced set is for further study.

## 7.8 System gain, coverage and deployment

This clause is provided to exemplify typical system gain coverage distances and deployment for the 42 GHz bands and by using the APT class 1 (EIRP = 33 dBm).

### 7.8.1 Evaluation of required system gain

#### 7.8.1.1 Assumptions and requirements

In the following it is reported an evaluation of the required system gain taking into account the HA system parameters.

Basic assumptions:

- Coverage radius: 2,3 km
- Rain zone: ITU-R K-zone
- Horizontal polarization

The following requirements depend on the frequency band:

Operating frequency band	40,5 GHz to 43,5 GHz	31,8 GHz to 33,4 GHz
Availability	99,985 %	99,99 %

Moreover it is assumed to use antennas with the following characteristics:

- **AP antenna gain:** 18 dBi  $\pm$  1 dB (90° sector antenna)
- **AT antenna gain:** 37 dBi  $\pm$  1 dB (30 cm diameter antenna)

In the following the 41 GHz scenario is analysed in detail. Similar calculation can be done with these assumptions for the 31 GHz as well.

#### 7.8.1.2 System gain calculation

The following refers to the 41 GHz band with a 99,985 % availability.

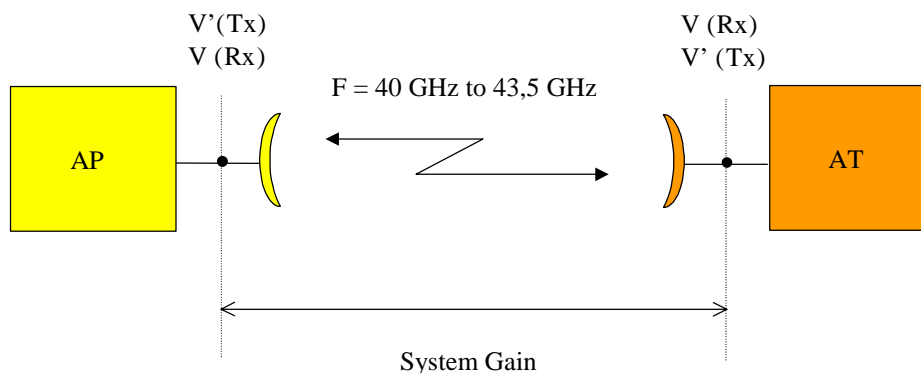


Figure 13: Reference system diagram

Considering that:

- Rain attenuation (Long term statistics) (see note 1) = 23 dB
- Free space loss (see note 2) = 132,4dB
- Antenna gain (see note 3) = 55 dB

NOTE 1:  $D = 2,5$  km, Availability = 99,985 %, Polarization = horizontal; Frequency = 43,5 GHz; Rain Zone = K (ITU-R Recommendation P.530-6 [23]; ITU-R Recommendation P.838 [24]; ITU-R Recommendation P.837-1 [25]).

NOTE 2: Free space loss =  $92,4 + 20 \times \log(43,5 \text{ GHz}) + 20 \times \log(2,3 \text{ km}) = 132,4$  dB.

NOTE 3: Antenna gain = AT antenna gain + AP antenna gain = 18 dB + 37 dB = 55 dB.

Then:

- **Required system gain** = Rain attenuation + Free space loss - Antenna gain  $\approx 100$  dB.

The **Required System Gain** for the system requirement above mentioned is 100 dB (@ 99,985 %).

## 7.8.2 Reference radio system conditions

The following radio system conditions should be considered as reference requirements for the HIPERACCESS system since they represent the typical scenario for such a system.

The following items are assumed:

- Required System Gain (@ 99,985 %) = 99 dB.
- **Channel spacing:** DownLink 28 MHz, Uplink 28 MHz.
- **Reference cellular pattern** with 2 frequencies and 2 polarization, with a certain overlapping degree as depicted in figure 13.

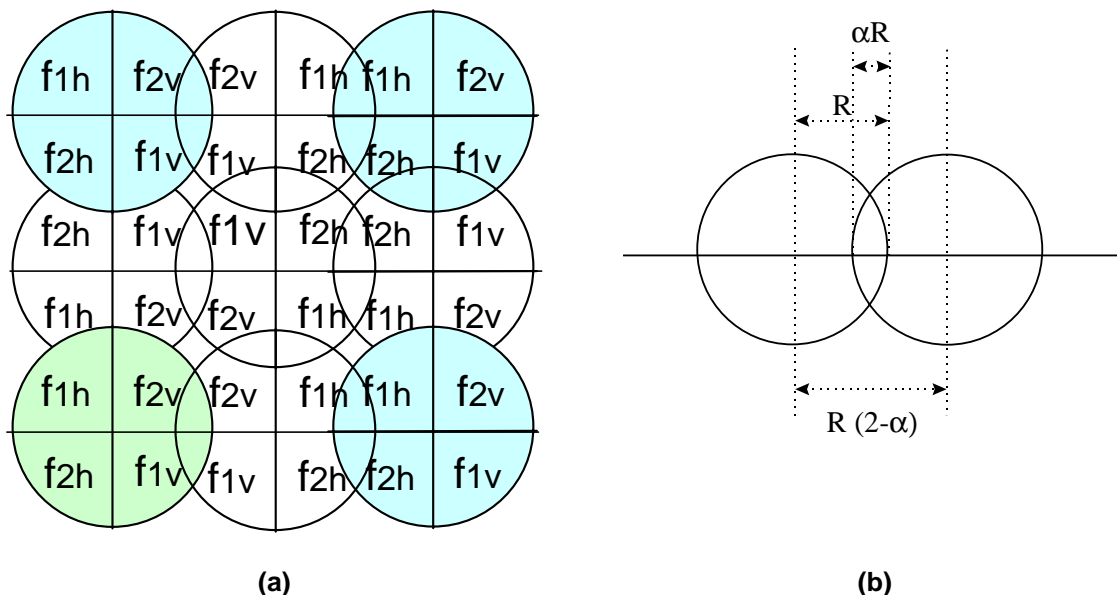


Figure 14: Reference cellular pattern (a) and overlapping degree (b)

### 7.8.3 Void

### 7.8.4 Availability and quality BER thresholds

The following BER thresholds are used in the following:

- BER =  $10^{-6}$  for link availability (that implies a CLR of about  $10^{-5}$ ).
- BER =  $10^{-11}$  for link quality.

### 7.8.5 RF Receiver input level thresholds

The receiver sensitivity corresponding to a given C/N for an equivalent noise bandwidth  $B_n$  and a noise figure NF is:

$$S_{th} = N_0 + NF + 10 \times \log_{10}(B_n) + \frac{C}{N} + \Delta loss + Rxloss$$

where:

- $\Delta loss$  includes all implementation losses
- Rxloss is the receiver branching loss

Table 9 shows the required input level receiver thresholds.

**Table 9: Receiver sensitivity for different carrier frequencies**

PHY Mode, inner code rate	Outer Code structure	C/N Required, BER = $10^{-6}$		P <sub>rx</sub> @ 26 and 28 GHz (C <sub>0</sub> ) [dBm]		P <sub>rx</sub> @ 32 GHz (C <sub>0</sub> ) [dBm]		P <sub>rx</sub> @ 42 GHz (C <sub>0</sub> ) [dBm]	
		C0 [dB]	$\Delta C1/C2$ [dB]	$10^{-6}$	$10^{-11}$	$10^{-6}$	$10^{-11}$	$10^{-6}$	$10^{-11}$
4QAM,1/2	RS(46,30)	5	+1	-88	-87	-87	-86	-86	-85
4QAM,2/3	RS(27,11)	7	+1	-86	-85	-85	-84	-84	-83
4QAM,2/3	RS(228,212)	8	+1	-85	-84	-84	-83	-83	-82
4QAM,1	RS(228,212)	12	+1	-81	-80	-80	-79	-79	-78
16QAM,7/8	RS(228,212)	18	+1	-75	-74	-74	-73	-73	-72
64QAM,5/6	RS(228,212)	25	+1	-68	-67	-67	-66	-66	-65
16QAM,1	RS(228,212)	20	+1	-73	-72	-72	-71	-71	-70
64QAM,1	RS(228,212)	27	+1	-66	-64	-65	-63	-64	-62

### 7.8.6 RF transmit output power

The RF transmit output power in this clause refers to the RF connection (point V' of figure 12).

The following figures are evaluated **not considering** the interference degradation effects on receiver threshold and the tolerances on transmit output power level.

Considering that:

- Required system gain = 100 dB (at 42 GHz).
- RF Receiver input level threshold for Downlink = -83 dBm (@ PHY mode M1, without interference).
- RF Receiver input level threshold for Uplink = -83 dBm (@ PHY mode M1, without interference).

Then the RF nominal transmit output power level for the AP (downlink) is:

$$P_{tx} = \text{Required system gain} + \text{RF Receiver input level thresholds}$$

$$P_{tx} = 15 \text{ dBm}$$

While the RF nominal transmit output power level for the AT (uplink) is:

$$P_{tx} = 14 \text{ dBm}$$

These values are regarded as a requirement towards manufacturers, while the scenario, used to derive them is only a reference: every HIPERACCESS operator can build its own different scenario.

On these output power values a tolerance of  $\pm 2$  dB will be considered in the following clauses.

### 7.8.7 Coverage range sensitivity

The power amplifier minimum requirement of 15 dBm can be played by different operators in different ways.

This clause shows the coverage and availability, in different frequency bands and different rain zones, that are achievable with the same transmit output power requested for the reference scenario in the 40 GHz band.

**Table 10: Coverage and availability sensitivity in different scenarios**

Scenario		Availability [%]	Coverage [km]
F [GHz]	Rain zone		
26	E	99,99	5,5
26	K	99,99	3,5
28	E	99,99	5,1
28	K	99,99	3,2
33,4	E	99,99	4,1
32	K	99,99	2,6
43,5	E	99,985	3,3
43,5	K	99,985	2,2

### 7.8.8 Void

### 7.8.9 Consequences due to the interference and PTx tolerances

Given the thresholds and transmit output power assumed as a typical reference scenarios, the following consequences are determined.

#### 7.8.9.1 Interference scenarios

Considering downlink and uplink transmission we have to face different interference scenarios due to the fact that the transmission is continuous and generated by the same AP in downlink, while it is burst based and generated by different AT in uplink.

The worst level of interference expected in *downlink* in some particular areas within the sector is:

$$\frac{C}{I} = 20 \times \log_{10}(5 - 2\alpha) - \Delta P + aa \times 4 \times r \text{ dB}$$

where:

- $\alpha$  is the overlapping factor,
- $\Delta P$  is the delta between antenna gains and RF power tolerances,
- $r$  is the cell radius,
- and  $aa$  is the atmospheric absorption.

A theoretical analysis can be performed considering a regular cell cluster with the same number of sites on the horizontal and in the vertical axis ( $n \times n$  configuration). Three cases can be considered:

- cluster  $3 \times 3$ , representative of the coverage of a small city, where the main disturbance is noise;

- cluster 5 x 5, representative of the coverage of a medium or a large city if the frequency band is 41 GHz or 26 GHz respectively;
- cluster 9 x 9, representative of the coverage of a very large city where the main disturbance is interference.

The C/I curves obtained from these configurations are reported in figure 15.

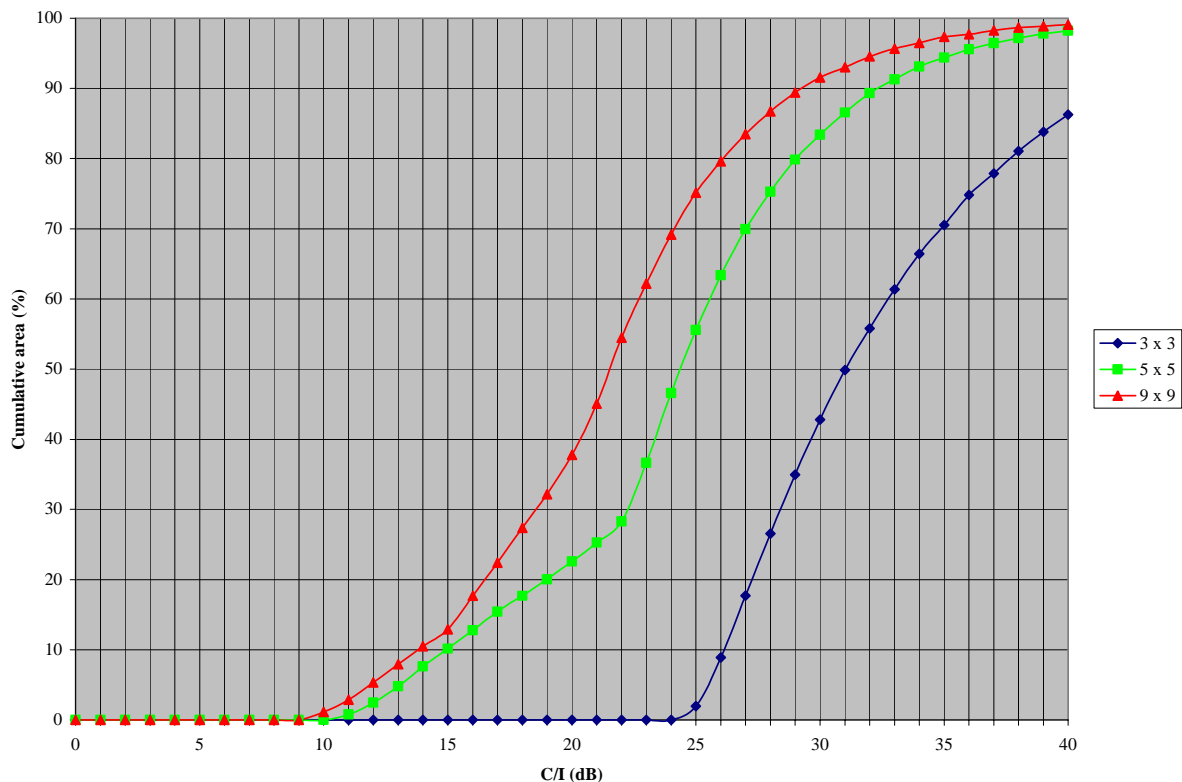


Figure 15 C/I curves

### 7.8.9.2 Coverage reduction due to interference and tolerances (PHY mode 1)

In the areas where there is an interference of about  $C/I = 14$  dB, the receiver sensitivity degradation due to interference on PHY mode 1 (the one used for availability) is about 1 dB. In this case the worst scenario in terms of tolerances (2 dB for amplifier, 1 dB + 1 dB due to antennas) has to be considered.

### 7.8.9.3 Availability of the radio link at 64QAM (PHY mode M4)

Everywhere the interference scenario allows to use 64QAM in clear sky conditions, the reduced receiver sensitivity (= -69 dBm @ PHY mode M4) reduces the high efficiency link availability to about 99,5 % at the cell border (due to reduced system margin of 8 dB, see table 11). Even considering 3 dB degradation due to interference PHY mode M4 is still available at the cell border in clear sky condition (5 dB of margin). The availability goal (99,985 %) is ensured by adaptive modulation.

Table 11: Available system margin for rain attenuation and for different modulation schemes in downlink (@2,5km, K zone, 99,985 % 4QAM availability)

PHY mode	Available system margin for Rain Attenuation [dB] (without Interference)	Available system margin for Rain Attenuation [dB] (with Interference) (see note)
M1	23	22 @ $C/I = 12$ dB
M4	8	5 @ $C/I = 27$ dB

NOTE: These theoretical margins are degraded by the proper amount due to interference specified (C/I).



### 7.8.9.4 RF Spectrum emission issues

The HIPERACCESS system is suitable to be deployed using the cellular pattern shown in figure 2, which employs two frequency and two polarization. The deployment with the reuse of the same frequency on each sector is very critical if not impossible. Therefore, it is always possible having non adjacent channels within a sector by simply assigning adjacent channels on different sectors. Nevertheless, it is possible having particular deployment scenarios (i.e. spare channels, block edge channels) where it is necessary to install two adjacent channels on the same sector.

In order to guarantee the co-existence of different modulation schemes used by systems operating on two 28 MHz copolar adjacent channels a **unique spectrum mask is required**. This mask shall be defined according to the requirements of higher order modulation scheme.

In order to guarantee the quality also for PHY mode M4 ( $C/I \geq 25$  dB @  $BER \leq 10^{-11}$ ) modulation scheme (downlink), the minimum Net Filter Discrimination required should be:

$$NFD \geq 31 \text{ dB}$$

as can easily be evaluated ( $\frac{C}{I} = (P+3) - (P+3) - NFD \geq 25$  dB) by considering the interference from two adjacent channels and the worst case (interference EIRP level = minimum +2 dB +1dB, useful EIRP level = minimum -2dB -1dB) for transmit power tolerances as depicted in figure 15.

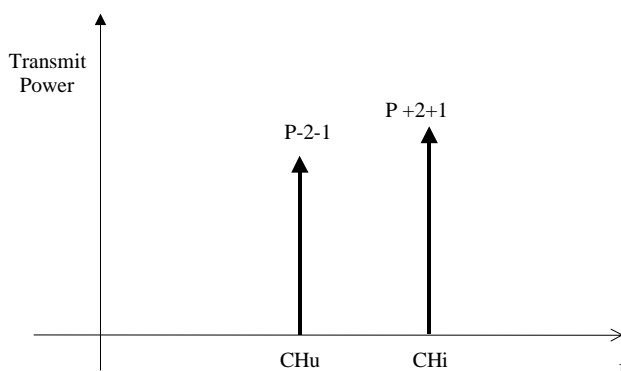


Figure 16: Relative transmit power levels in adjacent channels (worst case)

### 7.8.10 Adjacent and Co-channel Interference requirements

The limit of adjacent channel interference is given by:

$$\frac{C}{N_i} = \frac{C}{N_{cc}} - NFD$$

The Co-channel interference  $C/N_{cc}$  shall meet the following limit(implementation losses not considered):

#### CCI requirements

Description	BER = 10 <sup>-6</sup>	
	1 dB	3 dB
Threshold degradation	C/I (dB)	C/I (dB)
4QAM,2/3	12	9
4QAM,1	16	13
16QAM,7/8	21	18
64QAM,5/6	27	24
16QAM,1	23	20
64QAM,1	30	27

## 7.9 Multi-dwelling scenarios

As defined in the System Requirements [3], HIPERACCESS system can be deployed for residential customers and for highly dense urban areas. Consequently the most frequent environmental condition at the customer site is based on multi-tenant buildings.

In this case it will be necessary to share a single antenna, with the related outdoor unit (ODU), between different customers in order to:

- reduce the costs;
- reduce environmental impacts.

The second item especially could determine the success or not of this system. Two facts contribute as major points in the deployment of a broadband radio network:

- the increase of number of antennas on the roof of the buildings could result in the impossibility of installation due to the fact that the view of many antennas, even if small, is not pleasant;
- the connection between the ODU and the indoor unit (IDU) should be less intrusive as possible and possibly it should be done re-using the existing cables, or at least cable runs, inside the building.

The standard will not preclude realization of MDU architectures as discussed in this clause. Actual implementation of any of these schemes by manufacturers is optional.

## 8 Traffic and spectrum aspects

The following total spectrum estimation for Fixed Wireless Access Networks, which could be satisfied by HIPERACCESS, included in this clause, is based on a series of assumptions yet to be validated. Other scenarios have been considered, which vary the assumptions made relating to key parameters. These give results, which vary from slightly lower to rather higher requirements for the total amount of spectrum. The calculation is therefore believed to be a good representation of spectrum needs.

### 8.1 Service hypothesis

The model used for the spectrum evaluation is based on the service hypothesis shown in table 12.

**Table 12: Service hypothesis**

	Capacity [kbit/s]		Residential [%]		Business [%]	
	Down	Up	Penetration	Utilization	Penetration	Utilization
Voice	64	64	80	7	50	10
ISDN	144	144	10	7	5	10
Video Conference	384	384	10	7	5	10
VoD	3 000	32	50	3,3	0	0
Internet	25 000	5 000	80	1	50	1
Rem. LAN	25 000	25 000	10	0,25	5	0,5
Web serving	5 000	25 000	-	-	ME 75 SE 15 VSE 0,01	ME 80 SE 60 VSE 40

## 8.2 Area definition parameters

Two different typologies of area have been considered. The first one, reported in table 13, refers to high concentration residential areas. The second one, depicted in table 14, is an example of a high business concentration area. Case 2 differs from Case 1 in the concentration of residential and in the business distribution. Table 15 shows the different business distribution considered. Three different environments have been considered: City, City/Urban and Urban.

All the City and City/Urban calculations have been done with the hypothesis of a HIPERACCESS system market penetration value of 20 %.

It is important to underline that such a penetration could be higher in the Urban area, where the availability of optical fibre is likely to be less than in the City and City/Urban environment. Hence a market penetration value of 30 % has been used for urban areas.

In the city environment a smaller sector size has been considered respect to the City/Urban one, in order to take into consideration that in a very dense area many obstructions could be present and limit the visibility between AP and AT.

**Table 13: Area definition parameters (case 1: high residential area)**

	City	City/Urban	Urban
<b>Residential per km<sup>2</sup></b>	14 000	8 000	3 000
<b>Business per km<sup>2</sup></b>	600	350	100
<b>Sector radius [km]</b>	1,8	2,5	2,5
<b>Sector size [km]</b>	1,3	1,8	1,8
<b>Sector area [km<sup>2</sup>]</b>	1,6	3,1	3,1

**Table 14: Area definition parameters (case 2: high concentration business area)**

	City	City/Urban	Urban
<b>Residential per km<sup>2</sup></b>	10 000	5 500	2 000
<b>Business per km<sup>2</sup></b>	600	350	100
<b>Sector radius [km]</b>	1,8	2,5	2,5
<b>Sector size [km]</b>	1,3	1,8	1,8
<b>Sector area [km<sup>2</sup>]</b>	1,6	3,1	3,1

**Table 15: Penetration for business market**

Business type	ME	SE	VSE
Case 1			
Distribution [%]	0,9	6,0	93,1
Average number of employees		10	
Case 2			
Distribution [%]	7,0	20,0	73,0
Average number of employees		25	

It should be considered that in real applications there is no precise separation between high concentration residential and business areas. An interleaving between the two environments is often encountered. That is the reason for a flexible system able to manage both the situations at the same time.

## 8.3 Capacity per radio channel

The capacity per radio channel, considered for the spectrum evaluation, is reported in table 16, with the hypothesis of both downlink (DL) and uplink (UL) channel size of 28 MHz. Moreover a minimum modulation scheme with four level of modulation has been taken for both DL and UL. Adaptive modulation, with an average gain of 2, has been considered for DL, while no adaptive modulation has been taken for UL.

**Table 16: Example of capacity per radio channel (hypothesis)**

	Down	Up
Channel bandwidth [MHz]	28	28
Symbol rate [Msymbol/s]	22,4	22,4
M1 FEC efficiency	62 %	62 %
M1 modulation level [bit/symbol]	2	2
Adaptive modulation gain	2,2	1,1
Net capacity per channel [Mbit/s]	61,1	30,6

## 8.4 Traffic model

The capacity requirement evaluation is based on the sum of the data rate per each single customer and per each kind of service. This kind of calculation represents better the behaviour of dynamic channel allocation. The use of models such as Erlang B or Erlang C in order to define a number of channels on a type of service basis, determines an over dimensioning of the network, due to the fact that these models evaluate the needed bandwidth for each service without considering the sharing among them.

Table 17 reports the calculation of the traffic per user. As an example the value for a residential user, considering the voice service is calculated as follows:

$$\text{Service capacity} \times \text{Penetration} \times \text{Utilization} = 64 \text{ kbit/s} \times 80 \% \times 7 \% = 3,58 \text{ kbit/s}$$

For Business case the number of employees is also considered.

**Table 17: Traffic per user**

Service	Residential [kbit/s]		Business [kbit/s]	
	Down	Up	Down	Up
Voice	3,58	3,58	3,20	3,20
ISDN	1,01	1,01	0,72	0,72
Video conference	2,69	2,69	1,92	1,92
VoD	49,50	0,53	0,00	0,00
Internet	200,00	40,00	125,00	25,00
Remote LAN	6,25	6,25	6,25	6,25
Capacity per user	263,03	54,06	1 370,90	370,90
Web serving	0,00	0,00	54,19	270,93

## 8.5 Spectrum evaluation

### 8.5.1 Case 1: high residential area

Table 18 reports the calculation of capacity per sector and number of channel required with the hypothesis of a penetration of 20 % for the City and City/Urban environment and 30 % for the urban environment. All the calculations have been done considering a reuse factor of 2. In this case the evening busy hour has been considered. It corresponds to the time in which the maximum amount of traffic is measured over all the day. At this time all the residential traffic (100 %) has been taken into account, while only 10 % of the business traffic has been considered.

**Table 18: Spectrum requirements (high residential concentration area)**

	City		City/Urban		Urban	
	Down	Up	Down	Up	Down	Up
Capacity per km <sup>2</sup> [Mbit/s]	759,44	188,32	434,24	108,05	242,47	57,89
Channel bandwidth [MHz]	28	28	28	28	28	28
Channel capacity [Mbit/s]	60,3	29,0	60,3	29,0	60,3	29,0
Number of channels	42	22	46	24	14	8
Bandwidth required [MHz]	1 176	616	1 288	672	392	224
Capacity asymmetry ratio	1/4		1/4		1/4	

## 8.5.2 Case 2: high business concentration areas

Table 19 reports the same calculations given in table 18. Also in this case we have considered the evening busy hour, since the evaluation of the total offered traffic shows that this is the busy hour of all the day also in such area.

**Table 19: Spectrum requirements (high business concentration area)**

	City		City/Urban		Urban	
	Down	Up	Down	Up	Down	Up
Capacity per km <sup>2</sup> [Mbit/s]	603,20	299,33	334,33	171,01	177,10	80,24
Channel bandwidth [MHz]	28	28	28	28	28	28
Channel capacity [Mbit/s]	60,3	29,0	60,3	29,0	60,3	29,0
Number of channels	34	34	36	38	10	10
Bandwidth required [MHz]	952	952	1 008	1 064	280	280
Capacity asymmetry ratio	1/2		1/2		1/2	

## 8.6 Fixed link requirements

Any implementation of HIPERACCESS will require links between Access Point Transceivers (APT) and Access Point Controllers (APC) and beyond to core networks. TR 101 177 [3] points out that high capacity microwave links could be used to facilitate these connections.

By way of an example, the Mean Busy Hour (MBH) traffic figures derived in the previous clause suggest that the capacity required to feed a group of APTs in a point to multipoint configuration (4 assumed) could, in an urban deployment, reach 4 x STM-4 levels. Optimistically, developments in point to point technology and high capacity systems could evolve such that 4 x STM-4 fixed link capacity might be possible with future systems in a duplex spectrum channel assignment of around 2 x 224 MHz.

In a multi-operator urban deployment this requirement for point to point spectrum would clearly place large demands on the capacity of microwave fixed link frequency bands and could be difficult to satisfy. In full scale implementations, it may therefore be necessary to investigate other media to provide the supporting infrastructure.

## 8.7 UMTS Spectrum Requirements

On the basis of the traffic model, described in [27], relevant to the "worst case" UMTS traffic for central business district, foreseen for the year 2005, the following tables estimate the spectrum requirement for the UMTS infrastructure.

**Table 20a**

<b>Average HA DL net bit rate (Mbit/s)</b>	90
<b>Average HA UL net bit rate (Mbit/s)</b>	60
<b>HA 90° sector size (km<sup>2</sup>)</b>	4,50
<b>Market penetration</b>	40%

Table 20b

	Cell radius (km)	# of Node B/HA sector
UMTS BTS microcell	0,5	6
UMTS BTS picocell	0,125	92

Table 20c

City district - 2005 forecast	Total UMTS traffic (Mbit/s/km <sup>2</sup> )	UMTS traffic/sector (Mbit/s)	Spectrum requirement
Downlink	365	657	15 x 28 MHz
Uplink	259	466	16 x 28 MHz

NOTE: "Spectrum (# of 28 MHz)" = "UMTS traffic/sector" \* "reuse factor" / "Net 28 MHz system capacity"

It can be concluded that the total spectrum expected to be required by the HIPERACCESS system for the UMTS infrastructure support is 450 MHz duplex.

## 9 Radio aspects

This clause discusses aspects of the HIPERACCESS air interface, which needs particular attention.

### 9.1 Frequency bands and channel plans

Licensed versions of HIPERACCESS are expected to work in appropriate fixed service frequency bands.

HIPERACCESS will be based on FDD and a TDD version will be specified based on the FDD standard. Support for H-FDD terminals interoperable with FDD is required. TDD operation would enable use to be made of unpaired frequency allocations.

A large core allocation for large scale deployment is necessary. Several frequency bands are interesting for HIPERACCESS applications in the spectrum above 10 GHz.

The design of the protocols should therefore take account of the need for flexible allocations in the way that channel numbers and other parameters are defined.

### 9.2 System co-ordination

HIPERACCESS systems will be deployed in frequencies and geographical areas adjacent to other radio systems. To a greater or lesser degree, deployment will have to be co-ordinated with these other systems

Any frequency band allocated to HIPERACCESS and operator sub-divisions of the band should be defined so that operators should not have to co-ordinate deployment of HIPERACCESS with other radio systems in neighbouring bands. They should be able to plan their own deployment. The amount of co-ordination required with other HIPERACCESS operators in the core band should be minimal.

### 9.3 Spectrum sharing

The most common use of HIPERACCESS will be in licensed spectrum, where operators will have exclusive use of the assigned bands in particular regions. Since HIPERACCESS system requirements address both residential and business users and UMTS infrastructure, the quality of telecommunication services will be very high standard, licence exempt use is out of the scope of the HIPERACCESS standard.

## 9.4 Multiple operators

It must be possible to support several viable operators in a given area in the core HIPERACCESS spectrum. The radio aspects of the design should consider various deployment scenarios and allow for appropriate guard bands and other features to permit this.

# 10 Interoperability aspects

The HIPERACCESS standard will support interoperation at the air interface.

## 10.1 Definition of interoperability

Interoperability means the ability of an Access Termination (AT) designed and built according to the standards to interoperate with an Access Point designed and built independently to the same standards and to provide defined services according to an "interoperation profile" specification.

## 10.2 Requirements for interoperability

For inter-operable systems, the following will be specified:

- PHY layer specifications
- DLC layer specifications
- Interworking functions (to supported UNIs and SNIs)

IWFs (InterWorking Functions) occur at two points. One type of IWF is required to translate the internal (B2) interface of the HIPERACCESS network into network - specific interfaces of the particular core network (such as ATM). The other type of IWF is required to translate the internal (B1) interface of the HIPERACCESS network into external interfaces with Terminal Equipment. IWFs are logical entities and no particular physical location is implied by their position in the HIPERACCESS configuration diagram.

The IWFs are illustrated in the general reference model (see figure 16).

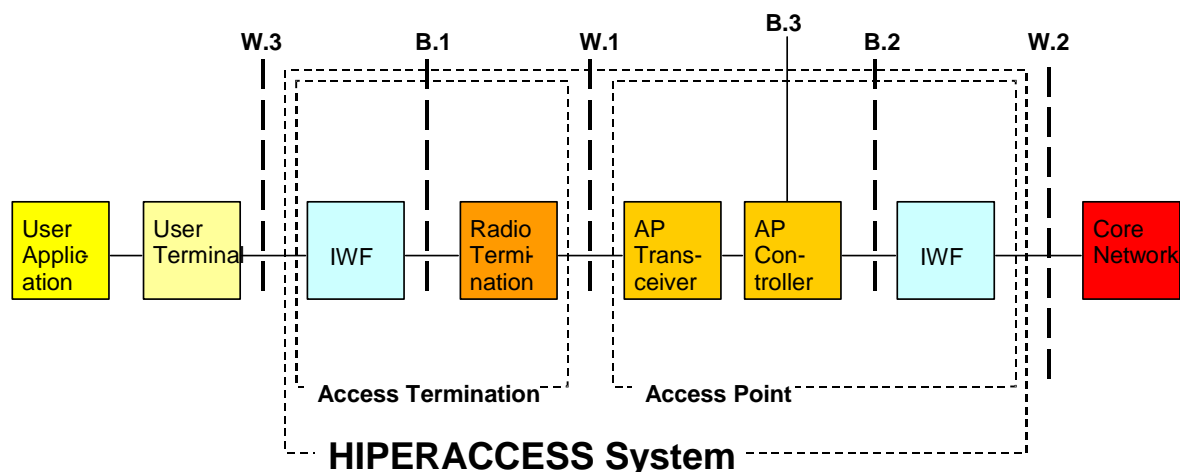


Figure 17: General reference model

Table 21: Interface requirements

Interface	Description	Requirement
W1	Internal air interface	To be fully specified in BRAN HIPERACCESS standards
W2	External interface to core network	Specified by other bodies; list of supported interfaces and related IWF definition shall be specified within the convergence sublayer HIPERACCESS standard
W3	External interface to user application/terminal	Specified by other bodies; list of supported interfaces and related IWF definition shall be specified within the convergence sublayer HIPERACCESS standard
B1	Internal Access Point (AP) service interface	Specified at logical level only; implementations may vary
B2	Internal Access Termination (AT) service interface	Specified at logical level only; implementations may vary
B3	External element management system (EMS) interface	Use of an available open standard protocol

For systems where inter-operability is required, HIPERACCESS standards shall define additional aspects, such as the following.

Identification and security issues:

- checks for legitimate use;
- fraud prevention;
- protection of traffic privacy;
- support requirements for legal interception.

Service management issues:

- control of services allowed;
- traffic statistics;
- charging for use of network.

Network management issues:

- control of network resources;
- control of routing;
- fault reporting.

---

## 11 Requirements for co-existence

Spectrum mask

The spectrum mask is defined in a frequency band around the centre frequency. It includes the useful bandwidth and the immediate bandwidth on either side of the useful bandwidth (for instance TM4 standards define the spectrum mask up to  $\pm 250\%$  of the Channel Spacing on each side of the centre frequency).

The definition of the spectrum mask consists of the relative power density level (defined in a given measurement bandwidth) relative to the centre power density.

The shape of the spectrum mask depends on several parameters, particularly the modulation format and the transmit filtering.



## Transmit Power/Power Control

The spectrum mask is defined only in relative terms and is not sufficient by itself to guarantee a particular level of immunity between different equipment or systems.

The definition of the absolute **maximum transmit power level** is necessary, in association with the definition of the antenna characteristics.

**Automatic Transmission Power Control (ATPC)** is a mechanism which allows control of the absolute power level at the output of the transmitter. The power can be varied, dependent on system characteristics such as cell size and propagation conditions, in order to minimize both inter- and intra-system interference. This mechanism is generally considered as optional for conventional low density radio systems but its provision may be mandatory to ensure satisfactory operation of high density systems like HIPERACCESS, requiring high spectrum efficiency and good frequency reuse.

During clear-air conditions, the transmit power can be set at a minimum level to achieve the required interference characteristics; during rain faded conditions, power control can increase the transmitted power to maintain the required overall radio coverage.

## Antenna characteristics

The specification of the main antenna characteristics - the **Antenna Gain** and the **Antenna Radiation Pattern** - may be necessary to limit on-axis e.i.r.p. and to achieve the required angular discrimination (both in azimuth and elevation).

If frequency reuse is required, additional antenna characteristics related to polarization discrimination may have to be specified.

## Receiver characteristics

Although receiver characteristics may not necessarily be considered as essential parameters to ensure co-existence, practically the specification of some of them may be useful:

- to minimize the effect of interference between radio systems;
- to ensure a guaranteed level of quality.

The parameters which are specified to minimize interference are:

- the receiver noise figure and bandwidth;
- the receiver frequency mask.

In addition, the minimum receiver sensitivity to achieve any requirement for guaranteed system quality is defined. This sensitivity level depends on the above mentioned receiver parameters, the modulation format and of the quality of the receiver design.

## Wideband noise

Wideband noise consists of undesired emissions outside the defined spectrum mask, and not generated by the modulation process. It consists of noise-like emissions but also of discrete spurious outputs. Wideband noise limits (applicable both to noise-like and discrete emissions) are specified in different ITU-R Recommendations (ITU-R Recommendation SM.329 [8] for generic limits and F.1191 [9] specifically for the Fixed Service); a CEPT Recommendation has recently been approved, which provides additional features to the ITU-R Recommendations.

## Channel arrangement

The definition of a channel arrangement is a means to allow proper operation of radio systems of a given Service to maximize the spectrum efficiency, minimize interference and ensure easy allocation of sub-bands to different users.

Conventional fixed service point-to-point channel arrangements consist of frequency slots of a given bandwidth corresponding to the same minimal channel spacing. Several bandwidths are generally defined and the channel arrangement for a given bandwidth is obtained by subdivision of the available overall bandwidth, or by concatenation of individual channels.

## Annex A: Application of HIPERACCESS system with passive optical network

### A.1 Network aspects

The variety of customer needs and mutations in telecommunication scenarios are imposing to Telcos the highest level of flexibility. Therefore new approaches, like those based on integration of wireless and optical technologies will result in an access network, where the customer perception of the services provided is media independent, but the flexibility allows network operators the deployment of the most suitable technology taking into account all constrains.

In order to have such a flexibility both from the network and service points of view the general requirements for wireless and optical technology should be identical. Furthermore, the interconnection of the two systems should be possible. The two systems should also be interchangeable - used in the same portion of the network they should provide similar network and service performance.

### A.2 Architecture

The generic architecture of an access network is defined by ITU-T Recommendation G.902 [10], whilst the reference configuration for an optical distribution network is stemming from ITU-T Recommendation G.982 [11].

In particular HIPERACCESS systems can be used within the access network as stand-alone systems directly connecting the user to the core network, as shown in figure A.1, or in an heterogeneous access network for deeper penetration to provide the last mile drop, as depicted in figure A.2.

The Terminal Station (TS) provides the user side interface between the broadband access network and the user terminals, i.e. the UNI interface, connected through the air interface to a Central Radio Station (CRS) that provides the network side interface of the access network, i.e. the SNI interface.

The Optical Network Unit (ONU), Optical Line Termination (OLT) and the Optical Distribution Network (ODN) are the usual elements of the FTTx architecture as defined by ITU-T Recommendation G.983.1 [12]. The reference point (R) represents the interface between ONU and CRS. This interface between the CRS and the ONU should be an ATM interface, since the FTTx system is ATM-based.

With reference to the general configuration as shown in the HIPERACCESS system Overview Report the UNI interface corresponds to interface W.3, while the interface W.2 corresponds to the SNI, or to Reference point (R).

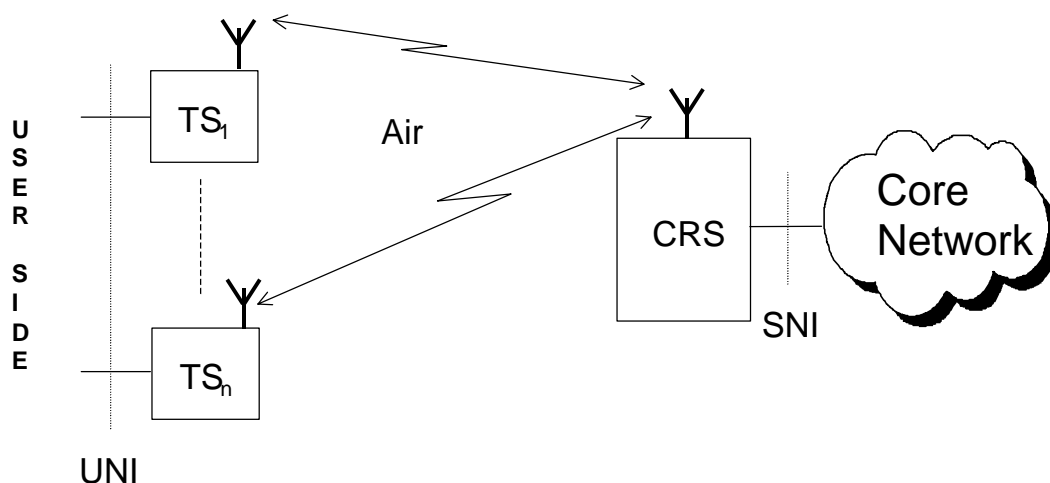


Figure A.1: Radio P-MP architecture

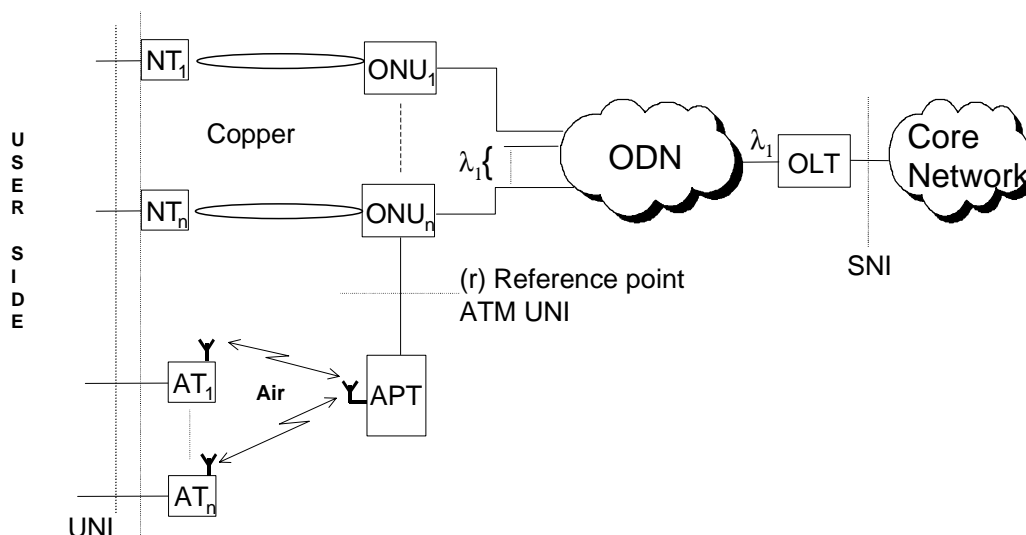


Figure A.2: Architecture for interconnection at ATM level

## A.3 System configuration

### A.3.1 Optical Line Termination

The Optical Line Termination (OLT) connects the PON over an SNI interface to service nodes. The OLT is responsible for managing all the PON specific aspects of the ATM transport system. The ONU and OLT provide transparent ATM transport service over the PON between the UNIs (Reference point R) and the SNI.

The OLT structure and functions are defined by ITU-T Recommendation G.983.1 [12].

### A.3.2 Optical Network Unit

The Optical Network Unit (ONU) interfaces over the  $IF_{PON}$  to the OLT, and to the UNI. Together with the OLT, the ONU is responsible for providing transparent ATM transport service between the NNI and the SNI.

In this architecture, the ATM transport protocols at an  $IF_{PON}$  are described as consisting of Physical Media Dependent layer, Transmission Convergence layer, and ATM layer. This architecture is only intended to address the transport of ATM, further detail is contained in ITU-T Recommendation I.732 [13]. The Transmission Convergence layer will be responsible for managing the distributed access to the upstream PON resource across the multiple ONUs. This is a key protocol element and will directly affect the resulting ATM QoS. The ATM protocols should see no change in the way they operate over the PON. Within both the OLT and the ONU, the functions performed at the ATM layer at both an OLT and ONU would include cell relaying.

The ONU structure and functions are defined by ITU-T Recommendation G.983.1 [12].

### A.3.3 Optical Distribution Network

The Optical Distribution Network provides the optical transmission means from the OLT towards the users and vice versa. It utilizes passive optical components.

The ODN structure and functions are defined by ITU-T Recommendation G.983.1 [12].

### A.3.4 HIPERACCESS system configuration

The HIPERACCESS system is described in previous part of the present document.

### A.3.5 Functional reference model for radio in FSAN Platform

Figure A.2 shows a HIPERACCESS system interconnected at the Reference point R with an FTTx platform. Figure A.3 shows the protocol model of an FSAN platform composed by OLT, ONU, CRS and TS based on ITU-T Recommendation I.321 [14], figure A.4 shows the functional model based on ITU-T Recommendation I.731 [15]. This configuration can be considered as a first step before reaching a complete integration of the two systems below the ATM level.

The DLC layer contains two sublayers: a Medium Access Control sublayer (MAC) and a Logical Link Control sublayer (LLC). The MAC sublayer implements a service policy that takes into account such factors as channel quality, number of terminal devices and medium sharing with other wireless subnetworks. The LLC sublayer maintains the quality of service on a virtual circuit basis. Depending on the type of service provided and channel quality, capacity and utilization, the LLC layer may implement a variety of means including FEC, ARQ and flow pacing to optimize the service provided to the (DLC) user. Physical layer contains the functions dealing with modulation, coding, etc.

The Wireless ATM Convergence Sublayer (WCS) is defined as a sublayer that generates no protocol but that provides the wireless DLC layer with the information it needs to perform its QoS management functions as required (e.g. the DLC could have parameters: VPI/VCI, cell loss priority, user data).

The Layer Management Entity (LME) of the DLC layer is used to convey traffic contract information and performance requirements between the DLC layer and the higher, connection control functions.

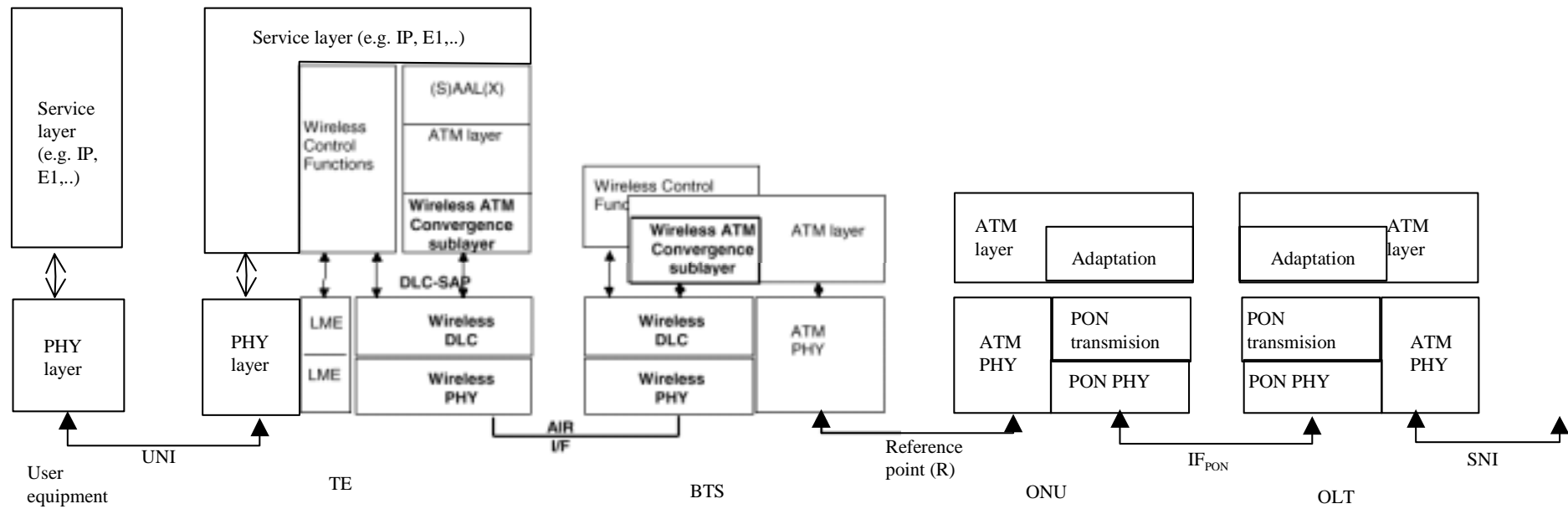
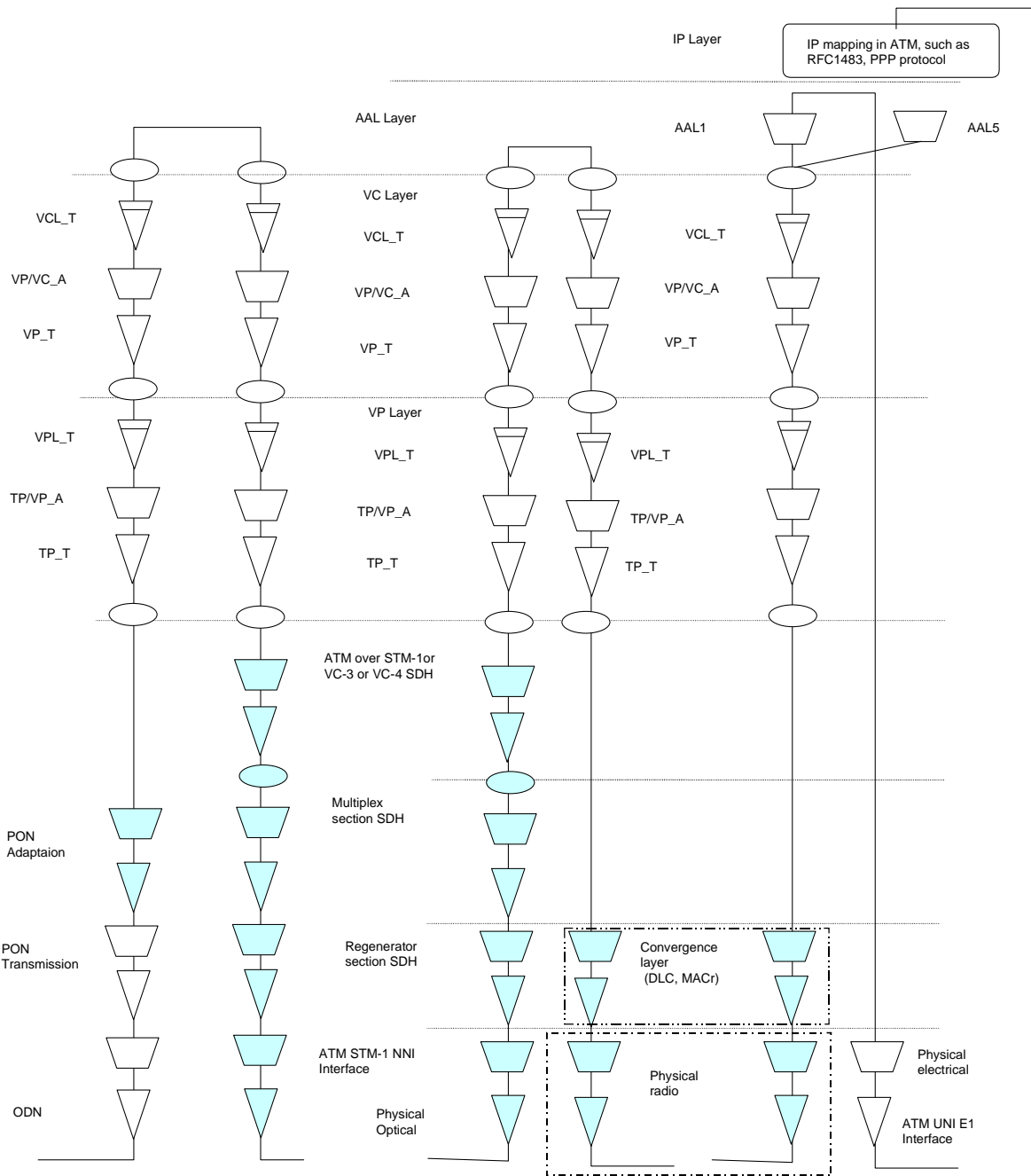


Figure A.3: HIPERACCESS system integrated into a FSAN platform



**Figure A.4: Functional model of a radio system connected to an ONU**

---

## History

<b>Document history</b>		
V1.1.1	March 2002	Publication