

**Satellite Earth Stations and Systems (SES);
Satellite Component of UMTS/IMT-2000;
Evaluation of the W-CDMA UTRA FDD
as a Satellite Radio Interface**



Reference

DTR/SES-00078

Keywords

interface, radio, satellite, UMTS, WCDMA

ETSI

650 Route des Lucioles
F-06921 Sophia Antipolis Cedex - FRANCE

Tel.: +33 4 92 94 42 00 Fax: +33 4 93 65 47 16

Siret N° 348 623 562 00017 - NAF 742 C
Association à but non lucratif enregistrée à la
Sous-Préfecture de Grasse (06) N° 7803/88

Important notice

Individual copies of the present document can be downloaded from:

<http://www.etsi.org>

The present document may be made available in more than one electronic version or in print. In any case of existing or perceived difference in contents between such versions, the reference version is the Portable Document Format (PDF). In case of dispute, the reference shall be the printing on ETSI printers of the PDF version kept on a specific network drive within ETSI Secretariat.

Users of the present document should be aware that the document may be subject to revision or change of status. Information on the current status of this and other ETSI documents is available at

<http://portal.etsi.org/tb/status/status.asp>

If you find errors in the present document, please send your comment to one of the following services:

http://portal.etsi.org/chaicor/ETSI_support.asp

Copyright Notification

No part may be reproduced except as authorized by written permission.
The copyright and the foregoing restriction extend to reproduction in all media.

© European Telecommunications Standards Institute 2004.
All rights reserved.

DECTTM, **PLUGTESTS**TM and **UMTS**TM are Trade Marks of ETSI registered for the benefit of its Members.
TIPHONTM and the **TIPHON logo** are Trade Marks currently being registered by ETSI for the benefit of its Members.
3GPPTM is a Trade Mark of ETSI registered for the benefit of its Members and of the 3GPP Organizational Partners.

Contents

Intellectual Property Rights	8
Foreword.....	8
Introduction	8
1 Scope	9
2 References	9
3 Definitions, symbols and abbreviations	11
3.1 Definitions	11
3.2 Symbols.....	11
3.3 Abbreviations	12
4 Satellite UMTS.....	13
4.1 System architecture	13
4.2 Frequency bands.....	14
4.2.1 Service link	14
4.2.2 Feeder links.....	14
4.3 Satellite system configuration	15
4.3.1 Global beam architecture	16
4.3.2 Multi-beam architecture.....	17
4.3.3 Extended multi-beam architecture	17
4.4 User Equipment (UE).....	18
4.5 Intermediate Module Repeater (IMR)	18
5 W-CDMA Satellite Radio Interface	19
5.1 General description.....	19
5.1.1 W-CDMA key features	19
5.1.2 Key technical characteristics.....	19
5.1.3 Radio Interface Protocol Architecture	20
5.2 Channel structure.....	20
5.2.1 Logical channels	21
5.2.1.1 Control channels	21
5.2.1.2 Traffic channels.....	21
5.2.2 Transport channels.....	22
5.2.2.1 Common Transport channels	22
5.2.2.2 Dedicated Transport channels	22
5.2.3 Logical to Transport channels mapping.....	22
5.2.4 Mapping and association of physical channels	24
5.2.4.1 Mapping of Transport channels onto Physical channels	24
5.2.4.2 Association of physical signals	24
5.3 Physical channel structure	25
5.3.1 Downlink physical channels	25
5.3.1.1 Dedicated physical channels	25
5.3.1.1.1 Frame structure.....	25
5.3.1.1.2 DL-DPCCH for CPCH.....	26
5.3.1.2 Common physical channels.....	27
5.3.1.2.1 Common Pilot CHannel (CPICH)	27
5.3.1.2.2 Synchronization CHannel (SCH)	27
5.3.1.2.3 Primary Common Control Physical CHannel (P-CCPCH)	28
5.3.1.2.4 Secondary Common Control Physical CHannel (S-CCPCH).....	28
5.3.1.2.5 Paging Indicator CHannel (PICH).....	29
5.3.1.2.6 Physical Downlink Shared CHannel (PDSCH)	30
5.3.1.2.7 Acquisition Indicator CHannel (AICH).....	30
5.3.1.2.8 CPCH Access Preamble Acquisition Indicator CHannel (AP-AICH).....	31
5.3.1.2.9 CPCH Collision Detection/CHannel Assignment Indicator CHannel (CD/CA-ICH)	31
5.3.1.2.10 CPCH Status Indicator CHannel (CSICH)	32
5.3.1.3 Spreading and modulation.....	32

5.3.2	Uplink Physical channels.....	34
5.3.2.1	Uplink dedicated physical channels	34
5.3.2.1.1	Frame structure.....	35
5.3.2.1.2	Spreading and modulation.....	35
5.3.2.2	Physical Random Access CHannel (PRACH)	37
5.3.2.2.1	Overall structure of random-access transmission	37
5.3.2.2.2	PRACH preamble part.....	37
5.3.2.2.3	PRACH message part.....	37
5.3.2.3	Physical Common Packet CHannel (PCPCH)	38
5.3.2.3.1	CPCCH transmission	38
5.3.2.3.2	CPCCH access preamble part	38
5.3.2.3.3	CPCCH collision detection preamble part	38
5.3.2.3.4	CPCCH power control preamble part	39
5.3.2.3.5	CPCCH message part.....	39
5.4	Channel coding and service multiplexing	39
5.4.1	Channel coding/interleaving for user services	39
5.4.1.1	CRC attachment	40
5.4.1.2	Transport block concatenation and code block segmentation	40
5.4.1.3	Channel coding	40
5.4.1.4	Radio frame size equalization	40
5.4.1.5	Radio frame segmentation.....	40
5.4.1.6	TrCH multiplexing.....	41
5.4.1.7	Insertion of discontinuous transmission (DTX) indication bits.....	41
5.4.1.8	Outer coding/interleaving.....	41
5.4.1.9	Rate matching	41
5.5	Radio Resource Functions.....	41
5.5.1	Initial spot search.....	41
5.5.1.1	Step 1: Slot synchronization.....	41
5.5.1.2	Step 2: Frame synchronization and code-group identification	42
5.5.1.3	Step 3: Scrambling-code identification	42
5.5.2	Random Access procedure.....	42
5.5.2.1	3GPP inherited procedure	42
5.5.2.2	Adaptation to satellite environment	43
5.5.2.2.1	Transmit power.....	43
5.5.2.2.2	Power ramp up procedure.....	43
5.5.2.2.3	Preamble collisions.....	43
5.5.2.2.4	AICH	45
5.5.2.2.5	Message part reception	45
5.5.3	Code allocation	45
5.5.4	Void	45
5.5.5	Power control.....	45
5.5.5.1	Open-loop power control	45
5.5.5.2	Layer 1 closed loop power control.....	46
5.5.5.2.1	Number of TPC commands per frame	46
5.5.5.2.2	Mechanization of the inner and outer loop	46
5.5.5.2.3	Layer 1 closed loop power control inhibition.....	46
5.5.5.3	Uplink Slow closed loop power control.....	47
5.5.5.3.1	Initial transmit power	47
5.5.5.3.2	Transmit power reconfiguration	47
5.5.5.4	Downlink Slow closed loop power control	48
5.5.5.4.1	Initial transmit power	48
5.5.5.4.2	Transmit power adjustment	48
5.5.6	Handover	48
5.5.6.1	Intra-frequency handover	48
5.5.6.1.1	Soft handover	48
5.5.6.1.2	Softer handover	49
5.5.6.2	Inter-frequency handover	49
5.5.6.2.1	Dual-receiver	49
5.5.6.2.2	Slotted downlink transmission.....	50
5.5.7	Spot Selection Transmit Diversity	50
5.6	W-CDMA Packet Access.....	50
5.6.1	Common-channel packet transmission	50

5.6.2	Dedicated-channel packet transmission	51
5.6.2.1	Single-packet transmission.....	51
5.6.2.2	Multi-packet transmission	51
5.7	Support of TDD.....	52
6	Performance requirements.....	52
6.1	Test environment support.....	52
6.1.1	Satellite environments.....	52
6.1.2	Intermediate Module Repeater environment.....	53
6.1.3	Combined Satellite and IMR environment	53
6.1.4	Aeronautical environment.....	54
6.2	Expected performances	55
6.2.1	Performance requirement for RACH	55
6.2.1.1	Preamble detection	55
6.2.1.2	Demodulation of RACH message	55
6.2.2	FACH demodulation requirements	56
6.2.3	Downlink DCH demodulation requirements	56
6.2.3.1	Summary of test measurement services	56
6.2.3.2	Margins	56
6.2.3.3	Demodulation in static conditions	57
6.2.3.4	Demodulation in ITU channel model A conditions	57
6.2.3.5	Demodulation in ITU channel model B conditions.....	58
6.2.3.6	Demodulation in ITU channel model C conditions.....	59
6.2.3.7	Demodulation in IMR environment conditions (no satellite signal reception)	60
6.2.3.8	Demodulation in combined satellite and IMR environment conditions	61
6.2.3.9	Demodulation in aeronautical environment	61
6.2.4	Uplink DCH demodulation requirements	62
6.2.4.1	Summary of test measurement services	62
6.2.4.2	Margins	62
6.2.4.3	Demodulation in static conditions.....	63
6.2.4.4	Demodulation in ITU channel model A conditions	63
6.2.4.5	Demodulation in ITU channel model B conditions.....	64
6.2.4.6	Demodulation in ITU channel model C conditions.....	64
6.2.4.7	Demodulation in IMR environment conditions (no satellite signal reception)	64
6.2.4.8	Demodulation in combined satellite and IMR environment conditions	64
6.2.4.9	Demodulation in aeronautical environment	65
6.2.5	Demodulation requirements synthesis	65
6.2.5.1	Propagation Link Margin	65
6.2.5.1.1	Satellite signal LOS view	65
6.2.5.1.2	Satellite signal NLOS view	66
6.2.5.2	Increasing interleaving depth	66
6.2.5.2.1	Downlink.....	66
6.2.5.2.2	Uplink.....	67
6.2.5.3	Spatial diversity.....	67
6.2.5.3.1	UE antenna diversity	67
6.2.5.3.2	Satellite diversity	67
6.2.5.4	Slow Power Control performance	72
6.2.5.4.1	Uplink Slow Power Control	73
6.2.5.4.2	Downlink Slow Power Control.....	75
6.2.5.5	Multi User Detection.....	77
6.2.6	Acquisition efficiency	78
6.3	Satellite transmitter characteristics	79
6.4	UE characteristics.....	81
6.5	IMR characteristics.....	81
7	System capacity.....	82
7.1	Downlink.....	82
7.1.1	Static environment	83
7.1.1.1	Data service 1,2 kbps	83
7.1.1.2	Speech service 4,75 kbps	83
7.1.1.3	Speech service 12,2 kbps	84
7.1.1.4	Data service 64 kbps	84

7.1.1.5	Data service 144 kbps	85
7.1.1.6	Data service 384 kbps	85
7.1.2	Rural environment, LOS	86
7.1.3	Sub-urban environment, LOS	87
7.1.4	Urban environment, LOS	88
7.1.5	Mobile environment without LOS and/or indoor penetration.....	89
7.1.6	Combined satellite and IMR environment	90
7.2	Uplink.....	90
7.2.1	Static environment	91
7.2.1.1	Data service 1,2 kbps	91
7.2.1.2	Speech service 4,75 kbps	91
7.2.1.3	Speech service 12,2 kbps	92
7.2.1.4	Data service 64 kbps	92
7.2.1.5	Data service 144 kbps	93
7.2.1.6	Data service 384 kbps	93
7.2.2	Rural environment, LOS	93
7.2.3	Sub-urban environment, LOS	94
7.2.4	Urban environment, LOS	95
7.2.5	Combined satellite and IMR environment	96
8	Technology design constraints	96
8.1	Doppler frequency shift.....	96
8.1.1	Doppler shift due to satellite movement	96
8.1.2	Doppler shift due to UE movement	97
8.2	Interoperability	97
8.2.1	Dual mode UEs.....	97
8.2.2	Intermediate Module Repeaters	97
8.2.3	Inter-system handover.....	97
8.2.4	Compatibility with existing systems	97
8.3	Performance enhancement features	98
8.4	System flexibility	98
9	Conclusion.....	99
Annex A:	Downlink Reference measurement channels.....	100
A.1	Data service 1,2 kbps.....	100
A.2	Speech 4,75 kbps	101
Annex B:	Uplink Reference measurement channels.....	102
B.1	Data service 1,2 kbps.....	102
B.2	Speech 4,75 kbps	102
Annex C:	Link budgets.....	103
C.1	Downlink.....	103
C.1.1	Data service 1,2 kbps.....	105
C.1.2	Speech service 4,75 kbps.....	106
C.1.3	Speech service 12,2 kbps.....	107
C.1.4	Data service 64 kbps.....	108
C.1.5	Data service 144 kbps.....	109
C.1.6	Data service 384 kbps.....	110
C.2	Uplink.....	111
C.2.1	Data service 1,2 kbps.....	112
C.2.2	Speech service 4,75 kbps.....	113
C.2.3	Speech service 12,2 kbps.....	114
C.2.4	Data service 64 kbps.....	115
C.2.5	Data service 144 kbps.....	116
C.2.6	Data service 384 kbps.....	117
Annex D:	System capacity - detailed results.....	118

D.1	Downlink.....	118
D.1.1	Mobile Satellite environment, LOS.....	118
D.1.1.1	Data service 1,2 kbps.....	119
D.1.1.2	Speech service 4,75 kbps.....	120
D.1.1.3	Speech service 12,2 kbps.....	121
D.1.1.4	Data service 64 kbps.....	122
D.1.1.5	Data service 144 kbps.....	123
D.1.1.6	Data service 384 kbps.....	124
D.1.2	Mobile environment without LOS and/or indoor penetration.....	125
D.1.2.1	Data service 1,2 kbps.....	125
D.1.2.2	Speech service 4,75 kbps.....	125
D.1.2.3	Speech service 12,2 kbps.....	126
D.1.2.4	Data service 64 kbps.....	126
D.1.2.5	Data service 144 kbps.....	127
D.1.2.6	Data service 384 kbps.....	127
D.1.3	IMR deployment.....	127
D.1.3.1	Data service 1,2 kbps.....	127
D.1.3.2	Speech 4,75 kbps.....	128
D.1.3.3	Speech 12,2 kbps.....	128
D.1.3.4	Data service 64 kbps.....	129
D.1.3.5	Data service 144 kbps.....	130
D.1.3.6	Data service 384 kbps.....	130
D.2	Uplink.....	131
D.2.1	Mobile Satellite environment, LOS.....	131
D.2.1.1	Data service 1,2 kbps.....	132
D.2.1.2	Speech service 4,75 kbps.....	133
D.2.1.3	Speech service 12,2 kbps.....	134
D.2.1.4	Data service 64 kbps.....	135
D.2.1.5	Data service 144 kbps.....	136
D.2.1.6	Data service 384 kbps.....	137
Annex E:	"W-CDMA" Radio transmission technologies description template.....	138
E.1	Test environment support.....	138
E.2	Technical parameters.....	138
E.3	Expected performances.....	147
E.4	Technology design constraints.....	149
E.5	Information required for terrestrial link budget template.....	152
E.6	Satellite system configuration.....	152
History	154

Intellectual Property Rights

IPRs essential or potentially essential to the present document may have been declared to ETSI. The information pertaining to these essential IPRs, if any, is publicly available for **ETSI members and non-members**, and can be found in ETSI SR 000 314: "*Intellectual Property Rights (IPRs); Essential, or potentially Essential, IPRs notified to ETSI in respect of ETSI standards*", which is available from the ETSI Secretariat. Latest updates are available on the ETSI Web server (<http://webapp.etsi.org/IPR/home.asp>).

Pursuant to the ETSI IPR Policy, no investigation, including IPR searches, has been carried out by ETSI. No guarantee can be given as to the existence of other IPRs not referenced in ETSI SR 000 314 (or the updates on the ETSI Web server) which are, or may be, or may become, essential to the present document.

Foreword

This Technical Report (TR) has been produced by ETSI Technical Committee Satellite Earth Stations and Systems (SES).

Introduction

The objective of using W-CDMA in a satellite environment is to ease integration of satellite and terrestrial UMTS. Some of the benefits to be gained from a fully integrated S-UMTS/T-UMTS system are:

- seamless service provision;
- re-use of terrestrial equipment: User Equipment and network infrastructure equipment (Node B, RNC, etc.);
- highly integrated multi-mode terrestrial/satellite terminals.

The satellite component of UMTS may provide services:

- in areas covered by cellular terrestrial systems, where terrestrial coverage requires capacity complement;
- in areas where terrestrial coverage is not available:
 - because terrestrial networks have not been deployed for business attractiveness reasons; or
 - because terrestrial system has suffered environmental damages (crisis conditions).

Based on the methodology defined by ITU-R, the outline of the present document is the following:

In clause 4, the system architecture and examples of candidate satellite constellations are presented.

Clause 5 summarizes key characteristics based on the Technical Specifications defined by 3GPP. Adaptation of radio resource functions to satellite environment is approached.

Clause 6 specifies test environment and equipment performance requirements.

Clause 7 presents system capacity.

Clause 8 summarizes constraints due to satellite environment.

The concluding clause 9 is a brief summary of the results established so far.

The present document is completed with five annexes. Annexes A and B specify reference measurement channels. Annex C provides typical link budgets. Annex D presents detailed system capacity results. Annex E is the ITU-R template used in M.1225 [1] the evaluation of the Radio Interfaces.

1 Scope

The present document evaluates the feasibility to use the W-CDMA UTRA FDD as a Satellite Radio Interface.

The Technical Specifications for the W-CDMA UTRA FDD has been developed in the framework of the third Generation Partnership Project (3GPP). This analysis is based on the Release 99 as defined in [10] to [31].

The procedure and methodology used for the evaluation of W-CDMA UTRA FDD as a Satellite Radio Interface are those defined in the Recommendations from ITU-R and which have been used for the evaluation of the radio transmission technologies candidate for the satellite component of UMTS/IMT-2000:

- ITU-R Recommendation M.1455 [2];
- ITU-R Recommendation M.1225 [1].

Without precluding the applicability of these results to other satellite constellation types, only the case of geostationary satellite is considered in the present document.

2 References

For the purposes of this Technical Report (TR), the following references apply:

- [1] ITU-R Recommendation M.1225: "Guidelines for evaluation of Radio Transmission technology for the International Mobile Telecommunications-2000 (IMT-2000)".
- [2] ITU-R Recommendation M.1455: "Key characteristics for the radio interfaces of the International Mobile Telecommunications-2000 (IMT-2000)".
- [3] ITU-R Recommendation M.1457: "Detailed specifications of the radio interfaces of the International Mobile Telecommunications-2000 (IMT-2000)".
- [4] ITU-R Recommendation M.1034-1: "Requirements for the radio interface(s) for International Mobile Telecommunications-2000 (IMT-2000)".
- [5] ITU server file 51640-ww7: "Proposal for Satellite IMT-2000 Standardisation".
- [6] ITU server file ESA-RTT-Self-Evaluation.pdf: "Evaluation Report by the European Space Agency IMT-2000 Satellite RTT Evaluation Committee", 30th September 1998.
- [7] ITU server file complian.pdf : "Table 1 for ESA satellite environment RTT proposals SW-CDMA and SW-CTDMA Technical Requirements and Objectives Relevant to the Evaluation of Candidate Radio Transmission Technologies".
- [8] ITU server file sw-cdma.pdf: "Wideband CDMA Option for the Satellite Component of IMT-2000 SW-CDMA ESA Proposal of a Candidate RTT Textural Description", v1.0, 27th June 1998.
- [9] ITU server file sw-cdma1.pdf: "ESA SW-CDMA Radio transmission technologies description template Description of the radio transmission technology".
- [10] ETSI TS 125 101: "UE Radio Transmission and Reception (FDD)".
- [11] ETSI TS 125 104: "UTRA (BS) FDD; Radio transmission and Reception".
- [12] ETSI TS 125 201: "Physical layer - General description".
- [13] ETSI TS 125 211: "Physical channels and mapping of transport channels onto physical channels (FDD)".
- [14] ETSI TS 125 212: "Multiplexing and channel coding (FDD)".
- [15] ETSI TS 125 213: "Spreading and modulation (FDD)".

- [16] ETSI TS 125 214: "Physical layer procedures (FDD)".
- [17] ETSI TS 125 215: "Physical layer - Measurements (FDD)".
- [18] ETSI TS 125 301: "Radio Interface Protocol Architecture".
- [19] ETSI TS 125 302: "Services provided by the Physical Layer".
- [20] ETSI TS 125 321: "MAC Protocol Specification".
- [21] ETSI TS 125 322: "RLC Protocol Specification".
- [22] ETSI TS 125 323: "PDCP Protocol Specification".
- [23] ETSI TS 125 324: "BMC Protocol Specification".
- [24] ETSI TS 125 331: "RRC Protocol Specification".
- [25] ETSI TS 125 401: "RAN Overall Description".
- [26] ETSI TS 125 402: "Synchronization in UTRAN Stage 2".
- [27] ETSI TS 125 141: "Base station conformance testing (FDD)".
- [28] ETSI TS 134 121: "Terminal Conformance Specification; Radio transmission and reception (FDD)".
- [29] ETSI TR 125 942: "RF System Scenarios".
- [30] ETSI TS 125 213: "Spreading and modulation (FDD)".
- [31] ETSI TS 125 433: "UTRAN Iub interface; NBAP Signalling".
- [32] ITU-R Recommendation SM.1541: "Unwanted emissions in the out-of-band domain".
- [33] ITU-R Recommendation M.1142: "Sharing in the 1-3 GHz frequency range between geostationary space stations operating in the Mobile Satellite Service and stations in the fixed service".
- [34] ETSI TR 101 865: "Satellite Earth Stations and Systems (SES); Satellite component of UMTS/IMT-2000; General aspects and principles".
- [35] ETSI TR 102 277: "Satellite Earth Stations and Systems (SES); Satellite Component of UMTS/IMT-2000; W-CDMA Radio Interface for Multimedia Broadcast/Multicast Service (MBMS)".
- [36] ERC Report 65: "Adjacent band compatibility between UMTS and other services in the 2 GHz band".
- [37] Satin: "Initial synchronisation procedure in S-UMTS networks for multimedia broadcast multicast services".
- [38] Satin: "Cell search procedure in S-UMTS networks".
- [39] Satin D5: "WP 5000 - S-UMTS Packet-based Layer 1 & 2 Functions".
- [40] Satin D7: "WP 6000 - Evaluations and Recommendation".
- [41] ECC PT1 (03)24: "First results of sharing and adjacent band compatibility studies between the terrestrial and satellite components of IMT-2000 in the 2,5 GHz band".
- [42] IEEE Vehicular, Vol. 51, N 2: "Wide-Band CDMA for the UMTS/IMT-2000 Satellite Component".
- [43] IEEE Antennas and Propagation, 1991. ICAP 91., Seventh International Conference on (IEE) , 15-18 April 1991: "Aeronautical Mobile Satellite Communication propagation characteristics in flight experiment using ETS-V".

- [44] ITU-T Recommendation G.726: "40, 32, 24, 16 kbit/s adaptive differential pulse code modulation (ADPCM)".
- [45] ITU-T Recommendation M.1224: "Vocabulary of terms for International Mobile Telecommunications-2000 (IMT-2000)".
- [46] ITU-T Recommendation G.711: "Pulse code modulation (PCM) of voice frequencies".

3 Definitions, symbols and abbreviations

3.1 Definitions

For the purposes of the present document, the following terms and definitions apply:

cell: geographical area under Intermediate Module Repeater coverage

downlink: unidirectional radio link for the transmission of signals from a satellite to a UE

forward link: unidirectional radio link for the transmission of signals from a gateway to a UE via a satellite

repeater: device that receives, amplifies and transmits the radiated or conducted RF carrier both in the down-link direction (from the satellite to the mobile area) and in the up-link direction (from the mobile to the satellite)

return link: unidirectional radio link for the transmission of signals from a UE to a gateway via a satellite

rice factor: power ration between LOS component and diffuse component

spot: geographical are under beam coverage

uplink: unidirectional radio link for the transmission of signals from a UE to a satellite

3.2 Symbols

For the purposes of the present document, the following symbols apply:

$\frac{DPCH_E_c}{I_{or}}$ ratio of the transmit energy per PN chip of the DPCH to the total transmit power spectral density at the Node B antenna connector

$\frac{E_b}{N_t}$ ratio of combined received energy per information bit to the effective noise power spectral density for the RACH, PCCPCH and DPCH at the receiver antenna connector. Following items are calculated as overhead: pilot, TPC, TFCI, CRC, tail, repetition, convolution and Turbo coding

I_{oc} power spectral density of a band limited white noise source (simulating interference from spots, which are not defined in a test procedure) as measured at the UE antenna connector

I_{or} received power spectral density of the downlink as measured at the UE antenna connector

3.3 Abbreviations

For the purposes of the present document, the following abbreviations apply:

ACLR	Adjacent CHannel Leakage Ratio
AI	Acquisition Indicator
AICH	Acquisition Indicator CHannel
AWGN	Additive White Gaussian Noise
BCCH	Broadcast Control CHannel
BCH	Broadcast CHannel
BER	Bit Error Rate
BLER	Block Error Ratio
BMC	Broadcast/Multicast Protocol
CCCH	Common Control CHannel
CCPCH	Common Control Physical CHannel
CCTrCH	Code Composite Transport CHannel
CDMA	Code Division Multiple Access
CPCH	Common Packet CHannel
CPICH	Common Pilot CHannel
CSICH	CPCH Status Indicator CHannel
CTCH	Common Traffic CHannel
DCCH	Dedicated Control CHannel
DCH	Dedicated CHannel
DL	Downlink
DPCCH	Dedicated Physical Control CHannel
DPCH	Dedicated Physical CHannel
DPDCH	Dedicated Physical Data CHannel
DSCH	Downlink Shared CHannel
DTCH	Dedicated Traffic CHannel
EIRP	Effective Isotropic Radiated Power
FACH	Forward Access CHannel
FBI	Feed Back Indicator
FDD	Frequency Duplex Division
FEC	Forward Error Correction
FSS	Fixed Satellite Service
FWA	Fixed Wireless Application
GEO	Geostationary Earth Orbit
GNSS	Global Navigation Satellite System
GPS	Global Positioning System
GSO	Geostationary Orbit
HEO	Highly-inclined Elliptical Orbit
HPA	High Power Amplifier
ICH	Indicator CHannel
IMR	Intermediate Module Repeater
LEO	Low Earth Orbit
LES	Land Earth Station
LOS	Line Of Sight
MAC	Medium Access Control
MBMS	Multimedia Broadcast Multicast Service
MCCH	MBMS Control CHannel
Mcps	Mega chip per second
MEO	Medium-altitude Earth Orbit
MES	Mobile Earth Station
MSS	Mobile Satellite Service
MTCH	MBMS Traffic CHannel
NCCH	Notification Common Control CHannel
NLOS	No Line Of Sight
OBO	Output Back Off
OVSF	Orthogonal Variable Spreading Factor
PCCH	Paging Control CHannel
P-CCPCH	Primary Common Control Physical CHannel

PCH	Paging CHannel
PCPCH	Physical Common Packet CHannel
PDCP	Packet Data Convergence Protocol
PDSCH	Physical Downlink Shared CHannel
PICH	Paging Indicator CHannel
PRACH	Physical Random Access CHannel
PSC	Primary Synchronization Code
QoS	Quality of Service
RACH	Random Access CHannel
RLC	Radio Link Control
RNC	Radio Network Controller
RNS	Radio Network Subsystem
RRC	Radio Resource Control
RTT	Radio Transmission Technology
SCH	Synchronization CHannel
S-MBMS	Satellite Multimedia Broadcast/Multicast Service
SNR	Signal to Noise Ratio
SRI	Satellite Radio Interface
SSC	Secondary Synchronization Code
SSTD	Spot Selection Transmit Diversity
TDD	Time Division Duplex
TFCI	Transport Format Combination Indicator
TPC	Transmit Power Control
TrCH	Transport CHannel
TTI	Time Transmission Interval
UE	User Equipment
UL	UpLink
USRA	UMTS Satellite Radio Access
USRAN	UMTS Satellite Radio Access Network
UTRA	UMTS Terrestrial Radio Access
UTRAN	UMTS Terrestrial Radio Access Network

4 Satellite UMTS

4.1 System architecture

Satellite UMTS (S-UMTS) addresses User Equipment (UE) fully compatible with 3GPP UTRA FDD mode (W-CDMA), with adaptation for agility to the Mobile Satellite Service (MSS) frequency band.

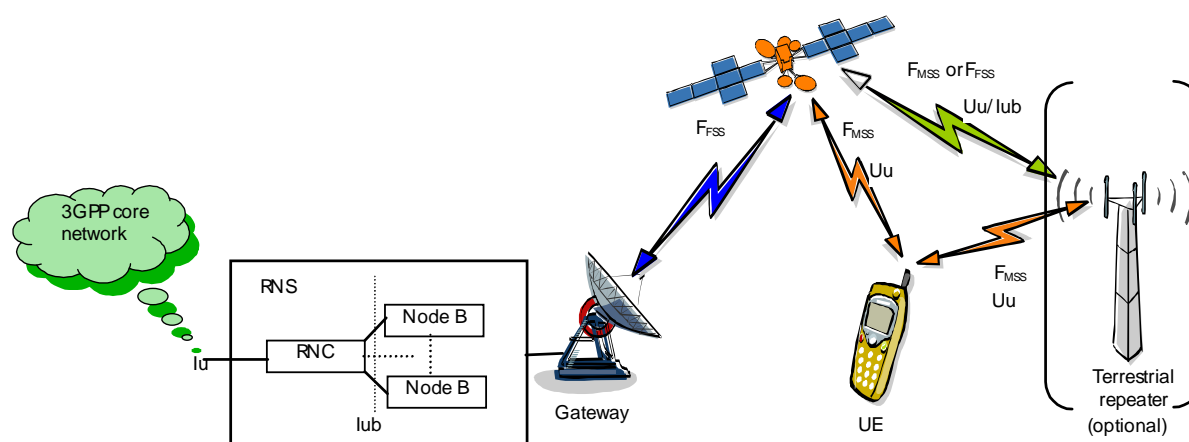

Figure 4.1: System architecture

The system may provide either single or multiple satellite constellation, each satellite may provide either mono or multi-spot coverage.

A location area may be either a spot or a group of spots for roaming users.

UEs are connected to the network via one or several satellites which redirect the radio signal to/from gateways. The system allows for either a centralized gateway or a group of geographically distributed gateways, depending on the operators requirements. The Gateway connects the signal to the Radio Network Subsystem (RNS), i.e. Node Bs and RNC. The decision to integrate Node Bs and/or RNC inside or outside the Gateway is under manufacturers implementation choice.

In a satellite environment, signal transmission is subject to suffer from path blocking due to buildings, mountains, etc. In order to ensure coverage continuity in highly shadowed areas, the system can be possibly completed with Intermediate Module Repeaters (IMRs) which role is to amplify and repeat the signal from the satellite to terrestrial coverage in the MSS frequency band and from terrestrial coverage to satellite. IMRs's feeder link is either in MSS or a Fixed Satellite Service (FSS) band. IMR's feeder link transmission/reception antenna is positioned in line of sight of the satellite.

On the system point of view, satellite and IMRs have the same functionality, which is reduced to signal repetition.

When IMRs are deployed, UEs are subject to communicate with the network:

- via the satellite only (areas where IMRs are not deployed or situation with no signal view from IMRs);
- via IMRs only (situation where there is no view of the satellite signal);
- simultaneously via satellite and IMRs.

In the present document, the term "spot" applies to beam coverage area while the term "cell" applies to IMR coverage area.

4.2 Frequency bands

4.2.1 Service link

The frequency bands are allocated in the IMT-2000 MSS band:

- 1 980 MHz to 2 010 MHz for the earth-to-space direction (UE uplink transmission to the satellite);
- 2 170 MHz to 2 200 MHz for the space-to-earth direction (UE downlink reception from the satellite).

These frequency bands are adjacent to the terrestrial UMTS frequency bands, as depicted in figure 4.2. The exploitation of adjacent bands should ease 3GPP standardized UE reuse provided they are adapted for MSS frequency agility.

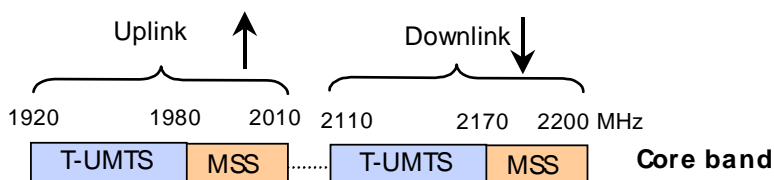

Figure 4.2: IMT-2000 spectrum allocation

4.2.2 Feeder links

The present document does not intend to specify feeder links. Nevertheless, some frequency bands are given for indication.

The gateway to satellite feeder link is intended to be operated in the 27,5 GHz to 30 GHz band.

Depending on the IMR configuration, the satellite to IMR feeder link is intended to be operated either:

- "On-channel" IMR: in the service link band (1 980 MHz to 2 010 MHz / 2 170 MHz to 2 200 MHz). This configuration is suitable for indoor coverage.
- "Non on-channel" IMR: in the HDFSS band (19,7 GHz to 20,2 GHz). This configuration is suitable for outdoor coverage.

4.3 Satellite system configuration

The system is able to cope with several satellite constellation types, i.e. LEO, HEO, MEO or GEO. It is out of the scope of the present document to restrict the satellite system configuration.

Nevertheless, in order to present realistic deployment scenarios, the present document focuses on the GEO constellation type.

Several architectures are envisaged depending on throughput requirements. The examples below assume European coverage. Global beam configuration means there is a unique spot covering the entire Europe area.

Multi-beam configuration means a satellite serves several spots, for instance 1 spot per linguistic area (7 multi-beam configuration) or 1 spot per regional area (extended multi-beam configuration).

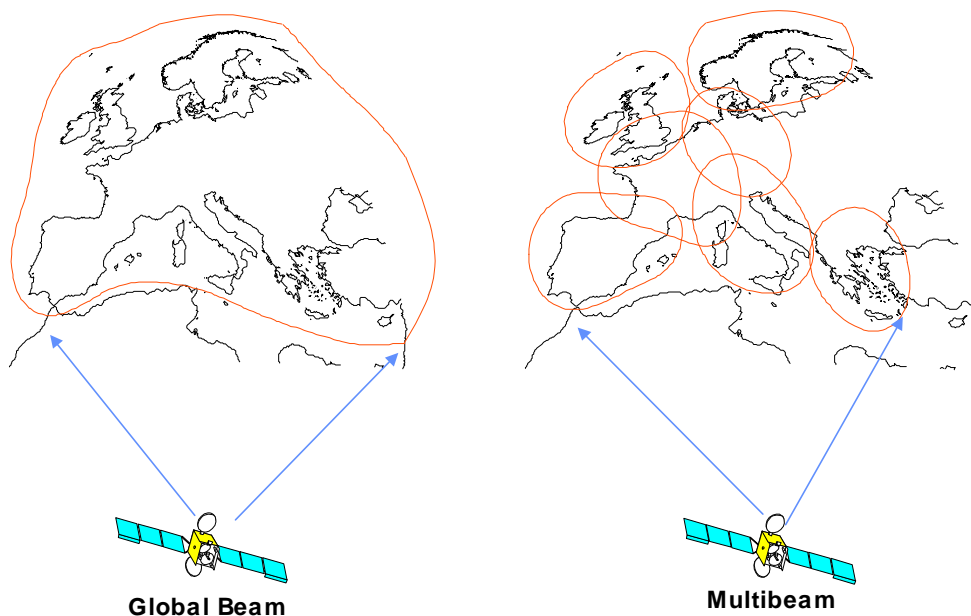

Figure 4.3: Global beam and 7 multi-beam satellite configuration

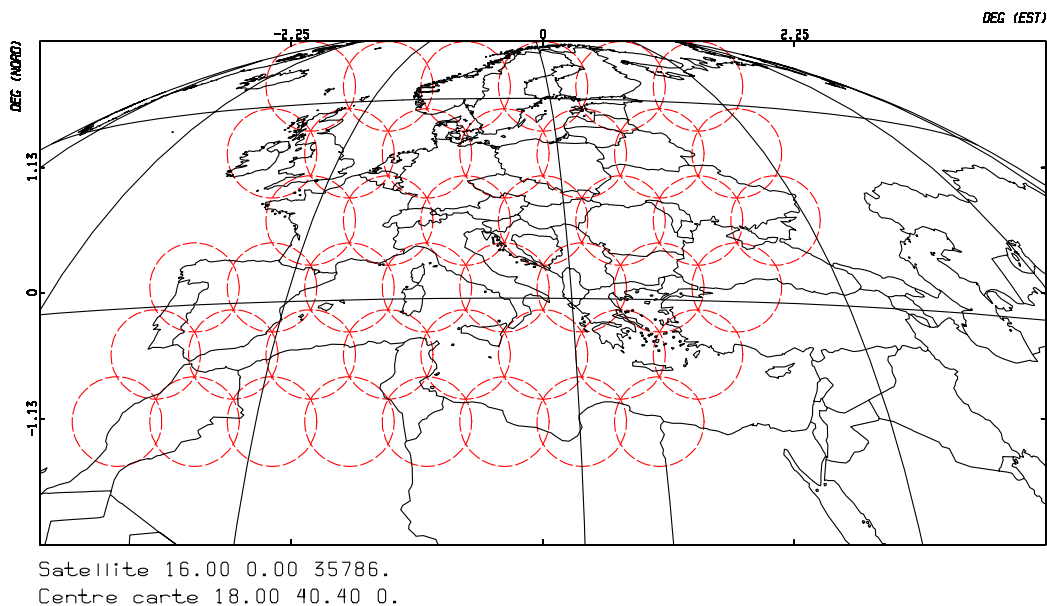

Figure 4.4: Extended multi-beam configuration

An other possible configuration is a system built with several satellites, each satellite serving several spots.

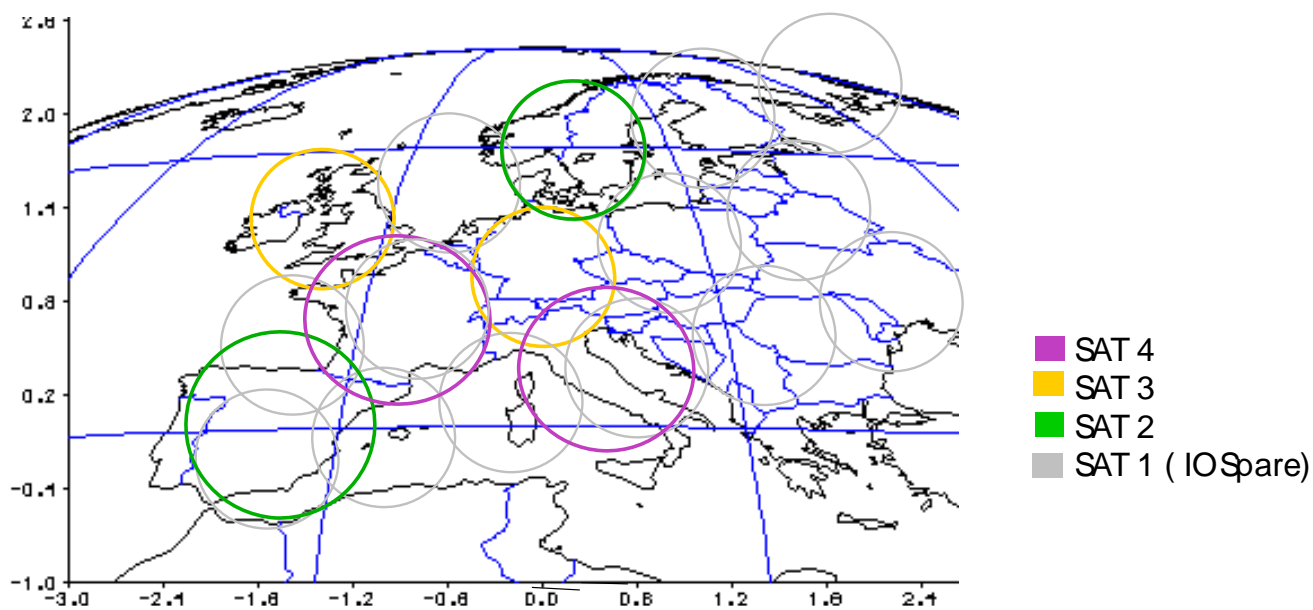

Figure 4.5: Multi-satellite and multi-beam configuration

4.3.1 Global beam architecture

The global beam architecture provides an overall throughput of 3,84 Mb/s over Europe shared among 2 FDMs. For instance, if 384 kbps service is provided, each FDM carries a maximum of 5 channel codes.

Each FDM occupies 5 MHz bandwidth among MSS frequency band.

Satellite performances are summarized in table 4.1.

Table 4.1: Satellite Global beam architecture

		Global beam
Number of spot beams		1
Downlink (satellite to UE)		
Frequency (satellite to UE)	MHz	2 170 - 2 200
Polarization		LHCP or RHCP
On board EIRP per carrier	dBW	64
Uplink		
Frequency (UE to satellite)	MHz	1 980 - 2 010
Polarization		LHCP or RHCP
Rx Antenna Gain	dB	~30

4.3.2 Multi-beam architecture

Satellite performances are summarized in table 4.2.

Table 4.2: Satellite 7 multi-beam architecture

		7 Multibeam
Number of spot beams		7
Downlink (satellite to UE)		
Frequency (satellite to UE)	MHz	2 170 - 2 200
Polarization		LHCP or RHCP
On board EIRP per carrier	dBW	From 64 to 74 (see note)
Uplink		
Frequency (UE to satellite)	MHz	1 980 - 2 010
Polarization		LHCP or RHCP
Rx Antenna Gain	dB	36 dB - 39 dB
NOTE: Depending on considered spot beam and frequency reuse pattern.		

4.3.3 Extended multi-beam architecture

Table 4.3: Satellite extended multi-beam architecture

		Extended Multibeam
Number of spot beams		30
Downlink (satellite to UE)		
Frequency (satellite to UE)	MHz	2 170 - 2 200
Polarization		LHCP or RHCP
On board EIRP per carrier	dBW	74
Uplink		
Frequency (UE to satellite)	MHz	1 980 - 2 010
Polarization		LHCP or RHCP
Rx Antenna Gain	dB	42 - 47

4.4 User Equipment (UE)

User Equipment (UE) may be of several types:

- **3G standardized handset:** the use in satellite environment requires adaptation for frequency agility to the MSS band. The basic assumption is UE power class 1, 2 and 3, equipped with standard omni-directional antenna.
- **Portable:** the portable configuration is built with a notebook PC to which an external antenna is appended.
- **Vehicular:** the vehicular configuration is obtained by mounting an RF module on car roof connected to the UE in the cockpit.
- **Transportable:** the transportable configuration is built with a notebook which cover contains flat patch antennas (manually pointed towards the satellite).
- **Aeronautical:** aeronautical configuration is built by mounting an antenna on top of the fuselage.

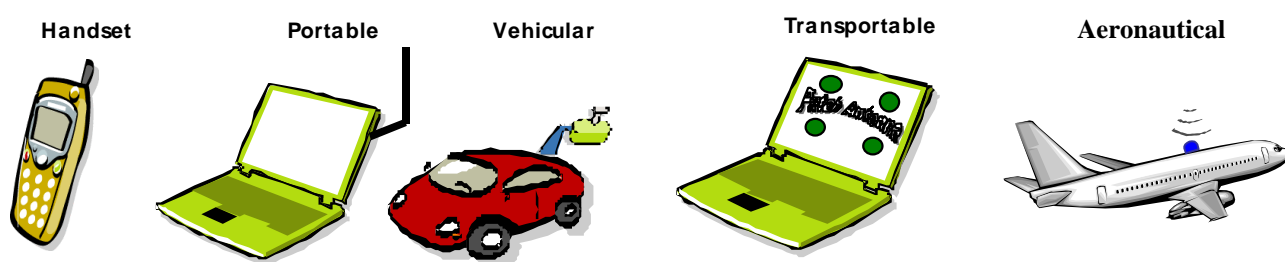

Figure 4.6: UE configurations

The power and gain characteristics for the four UE configurations are summarized in table 4.4.

Table 4.4: UE maximum transmit power, antenna gain and EIRP

UE type	Maximum transmit power	Reference antenna gain (see note)	Maximum EIRP	System temp.	G/T
3G Handset [10]					
Class 1	2W (33 dBm)	0 dBi	3 dBW	290 °K	-24,6 dB/°K
Class 2	500 mW (27 dBm)		-3 dBW		
Class 3	250 mW (24 dBm)		-6 dBW		
Portable	2 W (33 dBm)	2 dBi	5 dBW	200 °K	-21 dB/°K
Vehicular	8 W (39 dBm)	4 dBi	13 dBW	250 °K	-20 dB/°K
Transportable	2 W (33 dBm)	14 dBi	17 dBW	200 °K	-9 dB/°K
Aeronautical	2 W (33 dBm)	3 dBi	6 dBW		
NOTE: Typical values.					

4.5 Intermediate Module Repeater (IMR)

Two kinds of architecture can be envisaged:

- "On channel" repeaters: use the same band for signal reception and retransmission. The gain is limited to around 80 dB to avoid self-oscillation and offer narrow coverage.
- "Non on-channel" repeaters: use different frequency bands for signal reception and retransmission. They enable to achieve wider coverage than on-channel repeaters, but require an additional frequency band for feeding (e.g. HDFSS band).

Low-cost and low-power IMRs can be easily collocated to terrestrial UTRAN node B sites to provide the same coverage. They can also reuse some node B subsystems (e.g. sectorized antennas) since frequency bands for both satellite and terrestrial components of IMT-2000 are adjacent.

IMRs RF performance are summarized in table 4.5.

Table 4.5: IMR-RF performance

Receive frequency (MHz)	1 980-2 010
Transmit frequency (MHz) (see note)	2 170-2 200
Feeder link frequency	2 170-2 200; 1 980-2 010 or FSS Band for non-on channel repeaters
Receive polarization	RHCP or LHCP
Transmit polarization	Vertical
Minimum receive power level (dBm)	-78
Maximum receive power level (dBm)	-72
Overall EIRP (dBW)	Same as 3GPP Node B
Coverage area (°)	Up to 360° (e.g. 90° per sector)
NOTE: The transmit frequency band is equal to the received one (i.e. on-channel gap-filler).	

5 W-CDMA Satellite Radio Interface

This clause gives a description of the W-CDMA as applicable to the satellite environment.

5.1 General description

5.1.1 W-CDMA key features

Listed below are the key service and operational features of the W-CDMA radio-interface:

- Support for low data rate services (e.g. 1,2 kbps) up to high-data-rate transmission (384 kbps) with wide-area coverage.
- High service flexibility with support of multiple parallel variable-rate services on each connection.
- Efficient packet access.
- Built-in support for future capacity/coverage-enhancing technologies, such as adaptive antennas, advanced receiver structures, and transmitter diversity.
- Support of inter-frequency handover for operation with hierarchical cell structures and handover to other systems, including handover to GSM.

5.1.2 Key technical characteristics

Table 5.1: Key technical characteristics

Multiple-Access scheme	DS-CDMA
Duplex scheme	FDD
Chip rate	3,840 Mcps
Carrier spacing	5 MHz (200 kHz carrier raster)
Frame length	10 ms
Inter-spot synchronization	No accurate synchronization needed
Multi-rate/Variable-rate scheme	Variable-spreading factor + Multi-code
Channel coding scheme	Convolutional coding (rate 1/2 - 1/3) Turbo coding 1/3
Packet access	Dual mode (common and dedicated channel)

5.1.3 Radio Interface Protocol Architecture

Radio Interface protocol stack is extracted from TS 125 301 [18].

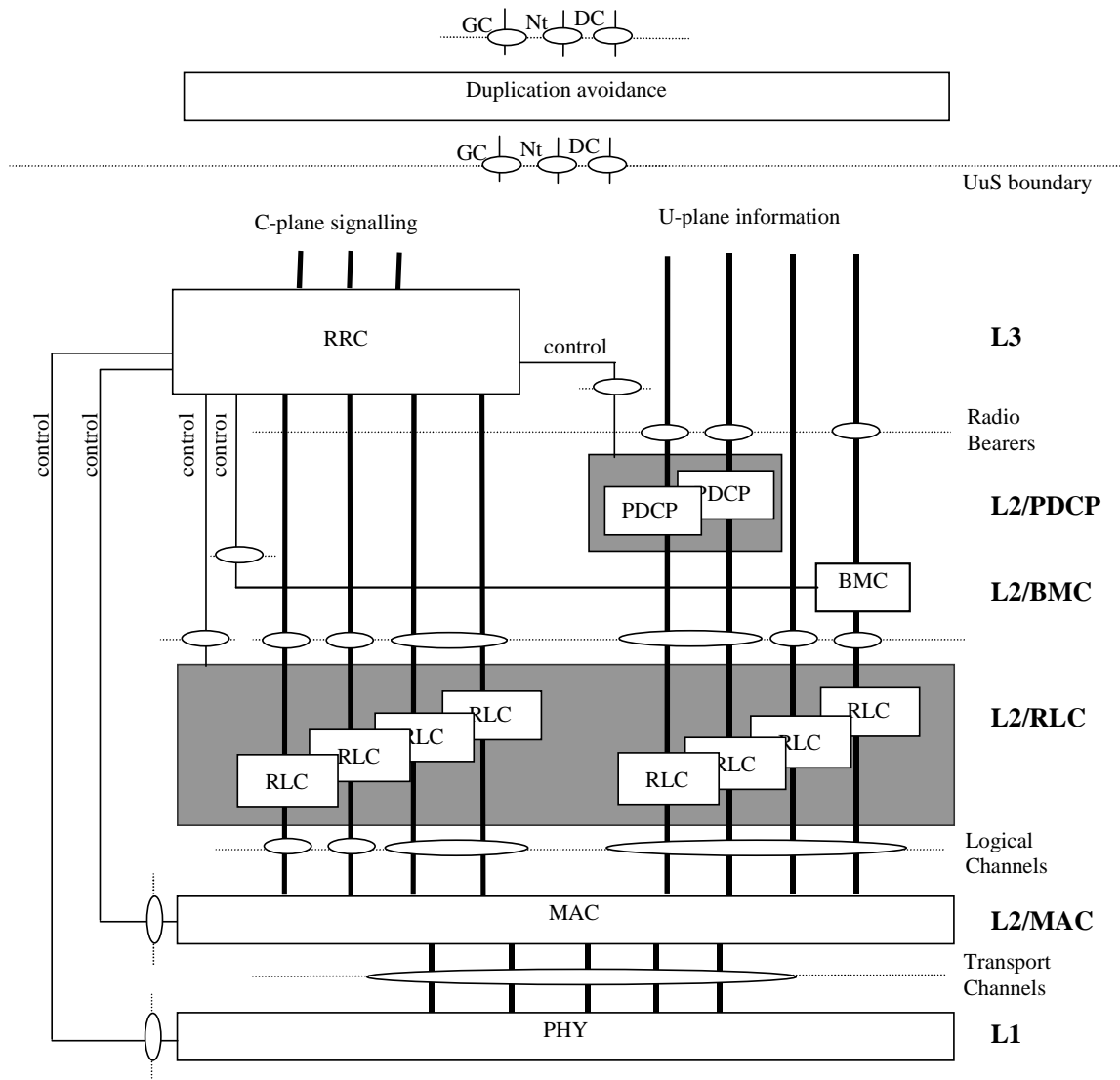

Figure 5.1: Radio interface protocol architecture

5.2 Channel structure

The channel structure is the same as in TS 125 301 [18]. It is described here for clarification.

5.2.1 Logical channels

The following logical channel types are defined [18]:

- Common Channels:
 - Broadcast Control Channel (BCCH);
 - Paging Control Channel (PCCH);
 - Random-Access Channel (RACH);
 - Common Control Channel (CCCH);
 - Common Traffic Channel (CTCH).
- Dedicated Channels:
 - Dedicated Control Channel (DCCH);
 - Dedicated Traffic Channel (DTCH).

These logical-channel types are described in more details below.

5.2.1.1 Control channels

BCCH - Broadcast Control Channel (DL)

The Broadcast Control Channel (BCCH) is a downlink point-to-multipoint channel that is used to broadcast system- and spot-specific information. The BCCH is always transmitted over the entire spot.

PCCH - Paging Control Channel (DL)

The Paging Control Channel (PCCH) is a downlink channel that is used to carry control information to a mobile station when the system does not know the location spot of the mobile station. The PCCH is always transmitted over the entire spot.

RACH - Random Access Channel (UL)

The Random Access Channel (RACH) is an uplink channel that is used to carry control information from a mobile station. The RACH may also carry short user packets. The RACH is always received from the entire spot.

CCCH - Common Control Channel

Bi-directional channel for transmitting control information between network and UEs. This channel is commonly used by the UEs having no RRC connection with the network and by the UEs using common transport channels when accessing a new spot after spot reselection.

DCCH - Dedicated Control Channel

A point-to-point bi-directional channel that transmits dedicated control information between a UE and the network. This channel is established through RRC connection set-up procedure.

5.2.1.2 Traffic channels

Traffic channels are used for the transfer of user plane information only.

DTCH - Dedicated Traffic Channel

A Dedicated Traffic Channel (DTCH) is a point-to-point channel, dedicated to one UE, for the transfer of user information. A DTCH can exist in both uplink and downlink.

CTCH - Common Traffic Channel

A point-to-multipoint unidirectional channel for transfer of dedicated user information for all or a group of specified UEs.

5.2.2 Transport channels

Transport channels are classified into two groups:

- **common transport channels**, where there is a need for inband identification of the UEs when particular UEs are addressed;
- **dedicated transport channels**, where the UEs are identified by the physical channel, i.e. code and frequency.

To each transport channel, there is an associated Transport Format (for transport channels with a fixed or slow changing rate) or an associated Transport Format Set (for transport channels with fast changing rate). A Transport Format is defined as a combination of encoding, interleaving, bit rate and mapping onto physical channels. A Transport Format Set is a set of Transport Formats.

5.2.2.1 Common Transport channels

Common transport channels are:

BCH - Broadcast Channel

A downlink channel used for broadcast of system information into an entire spot.

PCH - Paging Channel

A downlink channel used for broadcast of control information into an entire spot allowing efficient UE sleep mode procedures. Currently identified information types are paging and notification. Another use could be USRAN notification of change of BCCH information.

FACH - Forward Access Channel

Common downlink channel without closed-loop power control used for transmission of relatively small amount of data.

RACH - Random Access Channel

A contention based uplink channel used for transmission of relatively small amounts of data, e.g. for initial access or non-real-time dedicated control or traffic data.

CPCH - Common Packet Channel

A contention based channel used for transmission of bursty data traffic. This channel only exists in the uplink direction. The common packet channel is shared by the UEs in a spot and therefore, it is a common resource. The CPCH is fast power controlled.

DSCH - Downlink Shared Channel

A downlink channel shared by several UEs carrying dedicated control or traffic data.

5.2.2.2 Dedicated Transport channels

DCH - Dedicated Channel

A channel dedicated to one UE used in uplink or downlink.

5.2.3 Logical to Transport channels mapping

The mappings as seen from the UE and UTRAN sides are shown in Figure 5.2 and Figure 5.3 respectively.

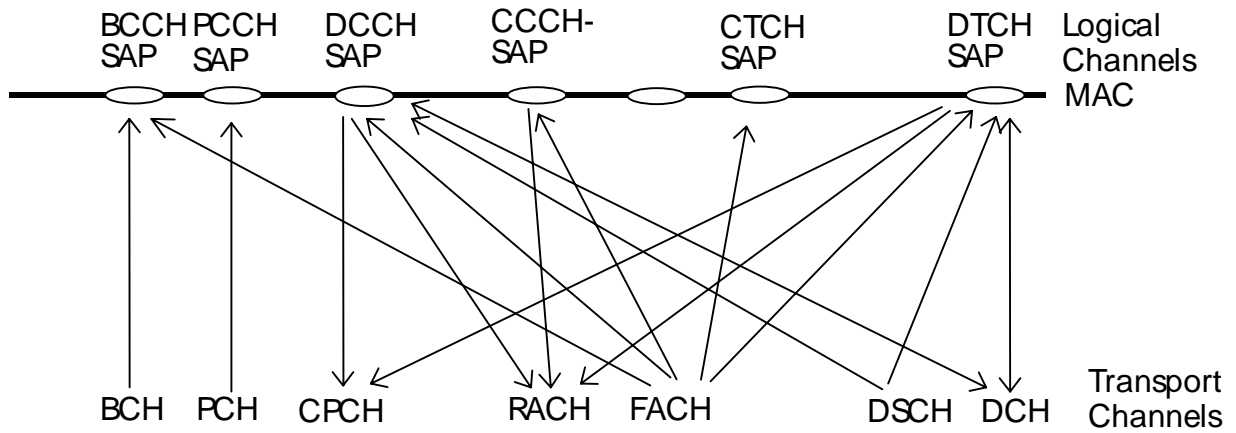

Figure 5.2: Logical channels mapped onto transport channels, seen from the UE side

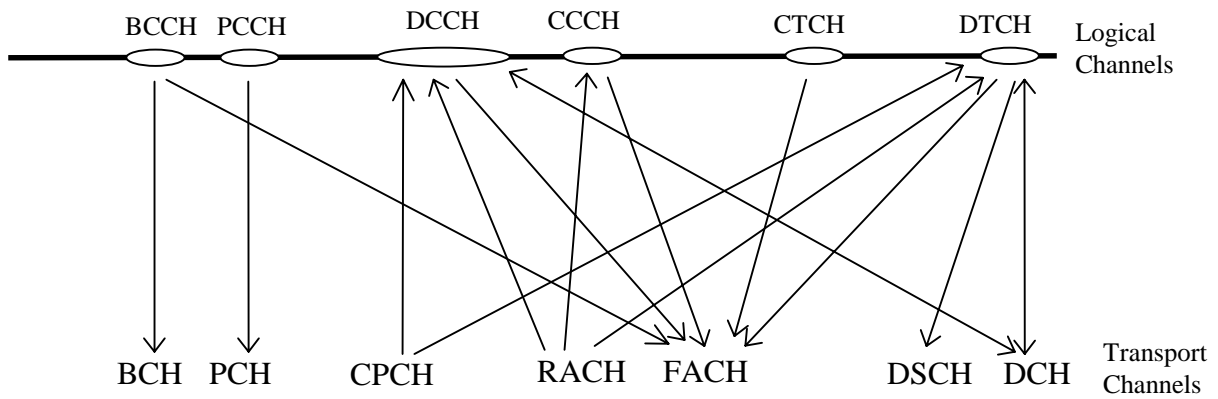

Figure 5.3: Logical channels mapped onto transport channels, seen from the UTRAN side

5.2.4 Mapping and association of physical channels

5.2.4.1 Mapping of Transport channels onto Physical channels

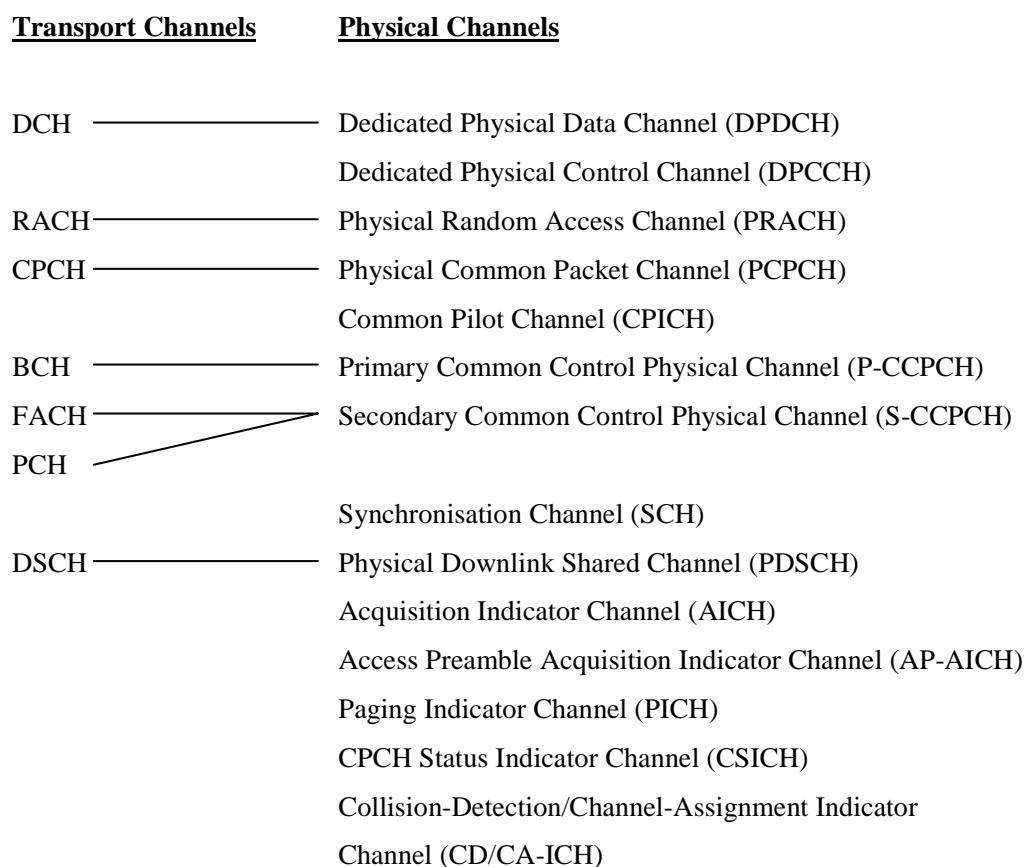

Figure 5.4: Mapping of Transport channels onto Physical channels

5.2.4.2 Association of physical signals

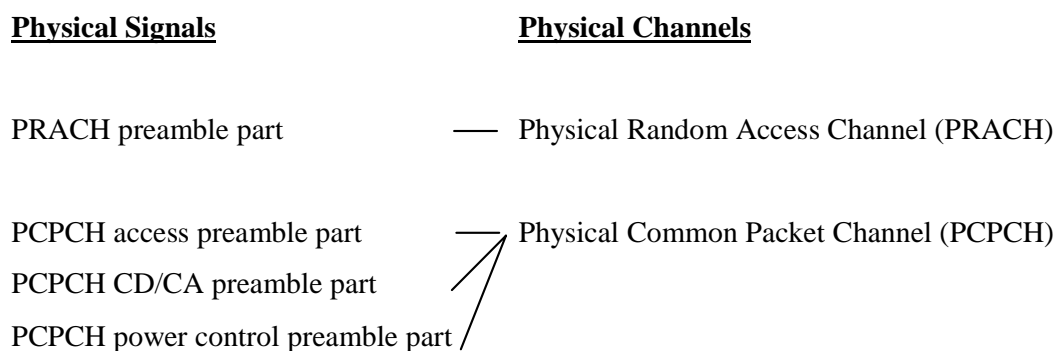

Figure 5.5: Physical channel and physical signal association

5.3 Physical channel structure

5.3.1 Downlink physical channels

5.3.1.1 Dedicated physical channels

There are two types of dedicated physical channels, the Dedicated Physical Data CHannel (DPDCH) and the Dedicated Physical Control CHannel (DPCCH).

DPDCH is used to carry dedicated data generated at layer 2 and above, i.e. the dedicated transport channels.

DPCCH is used to carry control information generated at layer 1. Control information consists of known pilot bits to support channel estimation for coherent detection, transmit power-control (TPC) commands, Transport Format Combination Indicator (TFCI).

The transport format combination indicator informs the receiver about the instantaneous rate of the different services multiplexed on the dedicated physical data channels. It is also possible, in the absence of TFCI, to use Blind Detection.

For the downlink, DPDCH and DPCCH are time multiplexed within each radio frame and transmitted with QPSK modulation.

5.3.1.1.1 Frame structure

Each frame of length 10 ms is split into 15 slots, each of length $T_{\text{slot}} = 0,666$ ms (2 560 chips). Within each slot, DPDCH and DPCCH are time multiplexed. Power control periods do not match fast fading correction due to satellite propagation time. Nevertheless, slot structure is kept unchanged in order to reduce modification requirements of terrestrial UE and Node B modems. Configuration and use of TPC bits in satellite environment is detailed in clause 5.5.5.

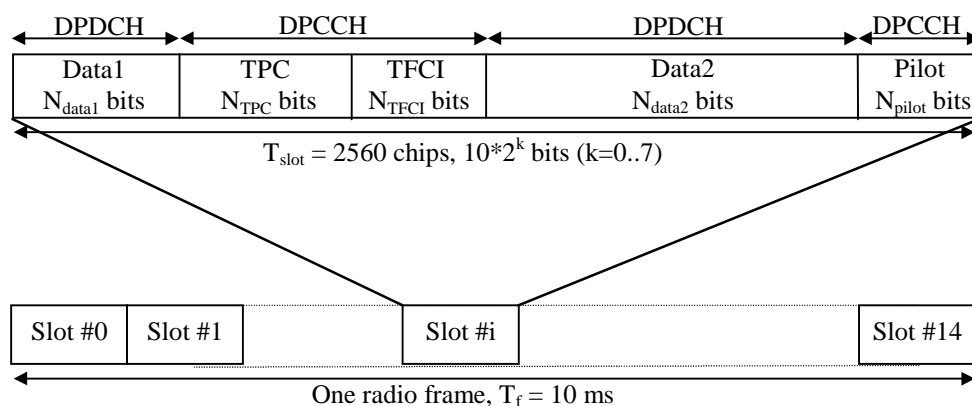

Figure 5.6: Frame structure of downlink dedicated physical channels

The parameter k in Figure 5.6 determines the total number of bits per downlink DPCH slot. It is related to the spreading factor SF of the physical channel as $SF = 512 / 2^k$. The spreading factor may thus range from 512 down to 4.

The exact number of bits of the different downlink DPCH fields (N_{pilot} , N_{TPC} , N_{TFCI} , N_{data1} and N_{data2}) is depending on the slot format. What slot format to use is configured by higher layers and can also be dynamically reconfigured by higher layers.

The slot format table from UTRAN is not modified for the satellite environment. Only the subset of this table adapted to satellite environment is used.

There are basically two types of downlink Dedicated Physical Channels; those that include TFCI (e.g. for several simultaneous services) and those that do not include TFCI (e.g. for fixed-rate services). It is up to the network to decide if a TFCI should be transmitted and it is mandatory for all UEs to support the use of TFCI in the downlink.

72 consecutive downlink frames constitute one W-CDMA super frame of length 720 ms.

Slot formats are extracted from 3GPP:

Table 5.2: DPCH slot format

Slot Format #i	Channel Bit Rate (kbps)	Channel Symbol Rate (ksps)	SF	Bits/Slot	DPDCH Bits/Slot		DPCCH Bits/Slot			Transmitted slots per radio frame N_{Tr}
					N_{Data1}	N_{Data2}	N_{TPC}	N_{TFCI}	N_{Pilot}	
0	15	7,5	512	10	0	4	2	0	4	15
1	15	7,5	512	10	0	2	2	2	4	15
2	30	15	256	20	2	14	2	0	2	15
3	30	15	256	20	2	12	2	2	2	15
4	30	15	256	20	2	12	2	0	4	15
5	30	15	256	20	2	10	2	2	4	15
6	30	15	256	20	2	8	2	0	8	15
7	30	15	256	20	2	6	2	2	8	15
8	60	30	128	40	6	28	2	0	4	15
9	60	30	128	40	6	26	2	2	4	15
10	60	30	128	40	6	24	2	0	8	15
11	60	30	128	40	6	22	2	2	8	15
12	120	60	64	80	12	48	4	8	8	15
13	240	120	32	160	28	112	4	8	8	15
14	480	240	16	320	56	232	8	8	16	15
15	960	480	8	640	120	488	8	8	16	15
16	1 920	960	4	1 280	248	1 000	8	8	16	15

5.3.1.1.2 DL-DPCCH for CPCH

The downlink DPCCH for CPCH is a special case of downlink dedicated physical channel of the slot format #0 in Table 5.2. The spreading factor for the DL-DPCCH is 512. The frame structure of DL-DPCCH for CPCH is depicted in figure 5.7.

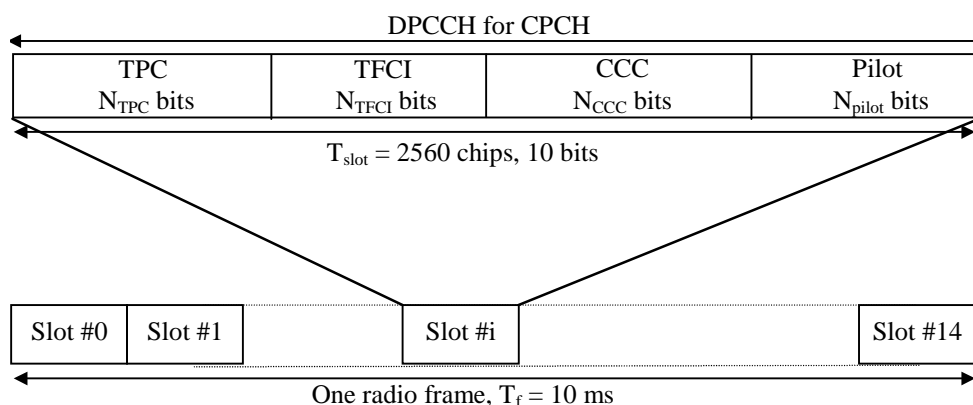

Figure 5.7: Frame structure for downlink DPCCH for CPCH

DL-DPCCH for CPCH consists of known pilot bits, TFCI, TPC commands and CPCH Control Commands (CCC). CPCH control commands are used to support CPCH signalling. There are two types of CPCH control commands: Layer 1 control command such as Start of Message Indicator, and higher layer control command such as Emergency Stop command. The exact number of bits of DL DPCCH fields (N_{pilot} , N_{TFCI} , N_{CCC} and N_{TPC}) is determined in by the slot format (pilot bit pattern: $N_{pilot} = 4$).

CCC field is used for the transmission of CPCH control command. On CPCH control command transmission request from higher layer, a certain pattern is mapped onto CCC field, otherwise nothing is transmitted in CCC field. There is one to one mapping between the CPCH control command and the pattern. In case of Emergency Stop of CPCH transmission, [1 111] pattern is mapped onto CCC field. The Emergency Stop command shall not be transmitted during the first $N_{Start_Message}$ frames of DL DPCCH after Power Control preamble.

5.3.1.2 Common physical channels

5.3.1.2.1 Common Pilot Channel (CPICH)

The Common Pilot Channel (CPICH) is a fixed rate (30 kbps, SF = 256) downlink physical channel that carries a pre-defined bit/symbol sequence.

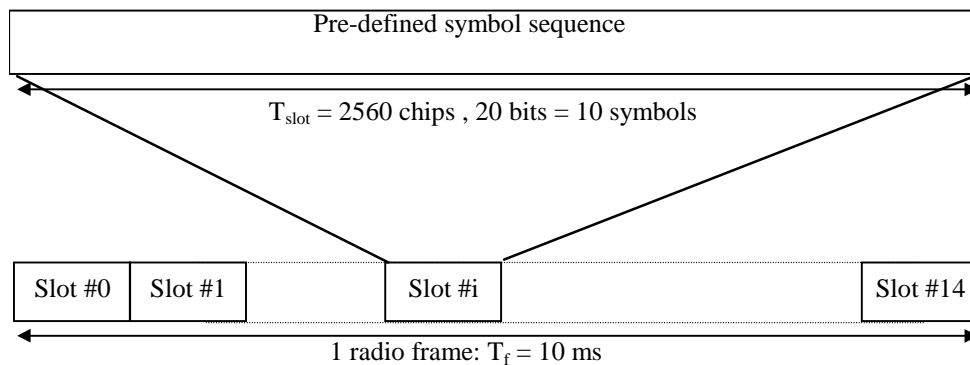

Figure 5.8: Frame structure of CPICH

Two types of Common pilot channels are defined, the Primary and Secondary CPICH. They differ in their use and the limitations placed on their physical features:

- Primary Common Pilot Channel (P-CPICH):
 - the same channelization code is always used for the P-CPICH;
 - the P-CPICH is scrambled by the primary scrambling code;
 - there is one and only one P-CPICH per spot;
 - the P-CPICH is broadcast over the entire spot;
 - the Primary CPICH is a phase reference for the downlink physical channels.
- Secondary Common Pilot Channel (S-CPICH):
 - an arbitrary channelization code of SF = 256 is used for the S-CPICH;
 - a S-CPICH is scrambled by either the primary or a secondary scrambling code;
 - there may be zero, one, or several S-CPICH per spot;
 - a S-CPICH may be transmitted over the entire spot or only over a part of the spot;
 - a Secondary CPICH may be a phase reference for a downlink DPCH.

5.3.1.2.2 Synchronization Channel (SCH)

The Synchronization Channel (SCH) is a downlink signal used for spot search. The SCH consists of two sub-channels, the Primary and Secondary SCH. The 10 ms radio frames of the Primary and Secondary SCH are divided into 15 slots, each of length 2 560 chips.

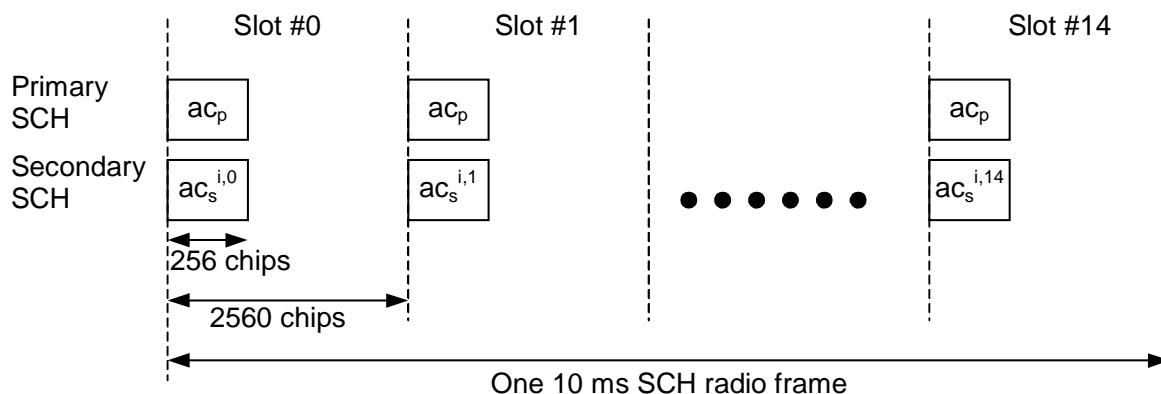

Figure 5.9: Structure of SCH

The Primary SCH consists of a modulated code of length 256 chips, the Primary Synchronization Code (PSC) denoted c_p in Figure 5.9, transmitted once every slot. The PSC is the same for every spot in the system.

The Secondary SCH consists of repeatedly transmitting a length 15 sequence of modulated codes of length 256 chips, the Secondary Synchronization Codes (SSC), transmitted in parallel with the Primary SCH. The SSC is denoted $c_s^{i,k}$ in Figure 5.9, where $i = 0, 1, \dots, 63$ is the number of the scrambling code group, and $k = 0, 1, \dots, 14$ is the slot number. Each SSC is chosen from a set of 16 different codes of length 256. This sequence on the Secondary SCH indicates which of the code groups the spot's downlink scrambling code belongs to.

5.3.1.2.3 Primary Common Control Physical CHannel (P-CCPCH)

The Primary CCPCH is a fixed rate (30 kbps, SF = 256) downlink physical channels used to carry the BCH transport channel.

The Primary CCPCH is not transmitted during the first 256 chips of each slot. Instead, Primary SCH and Secondary SCH are transmitted during this period.

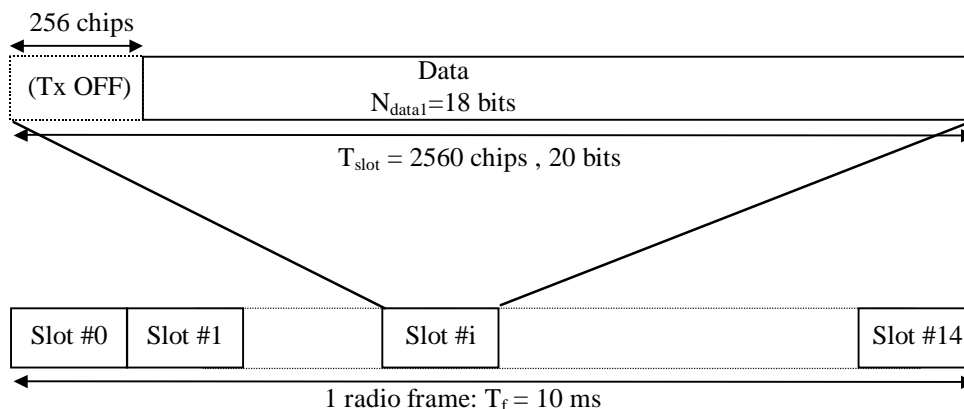

Figure 5.10: Frame structure of P-CCPCH

5.3.1.2.4 Secondary Common Control Physical CHannel (S-CCPCH)

The Secondary CCPCH is used to carry the FACH and PCH. There are two types of Secondary CCPCH: those that include TFCI and those that do not include TFCI. The set of possible rates for the Secondary CCPCH is the same as for the downlink DPCH.

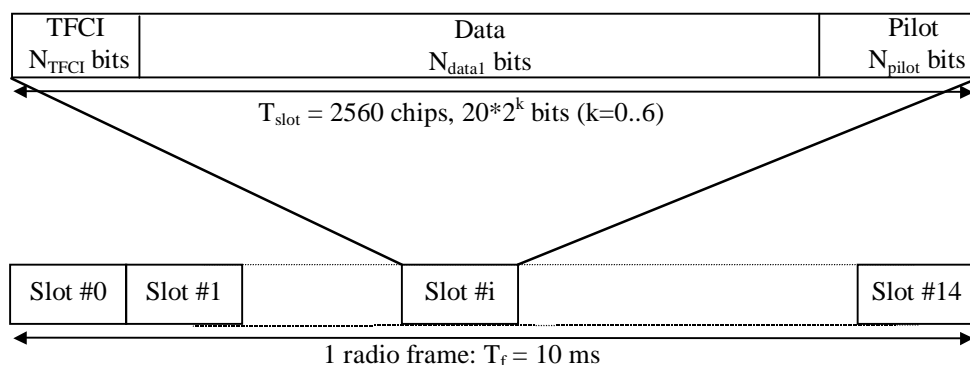

Figure 5.11: Frame structure of S-CCPCH

The parameter k in Figure 5.11 determines the total number of bits per downlink Secondary CCPCH slot. It is related to the spreading factor SF of the physical channel as $SF = 256 / 2^k$. The spreading factor range is from 256 down to 4.

The FACH and PCH can be mapped to the same or to separate Secondary CCPCHs. If FACH and PCH are mapped to the same Secondary CCPCH, they can be mapped to the same frame. The main difference between a CCPCH and a downlink dedicated physical channel is that a CCPCH is not inner-loop power controlled. The main difference between the Primary and Secondary CCPCH is that the transport channel mapped to the Primary CCPCH (BCH) can only have a fixed predefined transport format combination, while the Secondary CCPCH support multiple transport format combinations using TFCI.

Table 5.3: S-CCPCH slot formats

Slot Format #i	Channel bit rate (kbps)	Channel symbol rate (ksps)	SF	Bits/ Frame	Bits/ Slot	N _{data1}	N _{pilot}	N _{TFCI}
0	30	15	256	300	20	20	0	0
1	30	15	256	300	20	12	8	0
2	30	15	256	300	20	18	0	2
3	30	15	256	300	20	10	8	2
4	60	30	128	600	40	40	0	0
5	60	30	128	600	40	32	8	0
6	60	30	128	600	40	38	0	2
7	60	30	128	600	40	30	8	2
8	120	60	64	1 200	80	72	0	8
9	120	60	64	1 200	80	64	8	8
10	240	120	32	2 400	160	152	0	8
11	240	120	32	2 400	160	144	8	8
12	480	240	16	4 800	320	312	0	8
13	480	240	16	4 800	320	296	16	8
14	960	480	8	9 600	640	632	0	8
15	960	480	8	9 600	640	616	16	8
16	1 920	960	4	19 200	1 280	1 272	0	8
17	1 920	960	4	19 200	1 280	1 256	16	8

5.3.1.2.5 Paging Indicator CHannel (PICH)

The Paging Indicator CHannel (PICH) is a fixed rate ($SF = 256$) physical channel used to carry the paging indicators. The PICH is always associated with an S-CCPCH to which a PCH transport channel is mapped.

One PICH radio frame of length 10 ms consists of 300 bits. Of these, 288 bits are used to carry paging indicators. The remaining 12 bits are not formally part of the PICH and shall not be transmitted. The part of the frame with no transmission is reserved for possible future use.

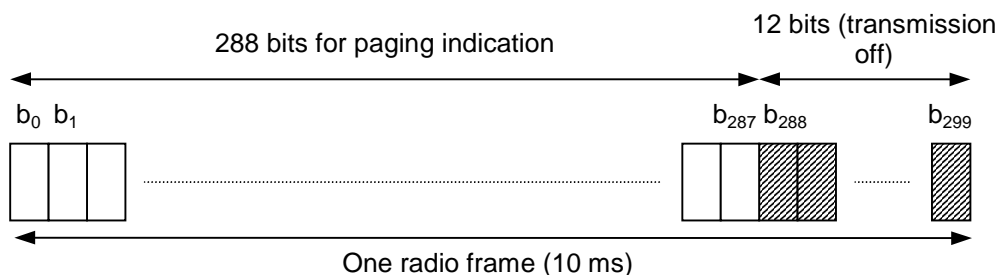

Figure 5.12: Structure of PICH

5.3.1.2.6 Physical Downlink Shared CHannel (PDSCH)

The Physical Downlink Shared CHannel (PDSCH) is used to carry the Downlink Shared CHannel (DSCH).

A PDSCH is allocated on a radio frame basis to a single UE. Within one radio frame, UTRAN may allocate different PDSCHs under the same PDSCH root channelization code to different UEs based on code multiplexing. Within the same radio frame, multiple parallel PDSCHs, with the same spreading factor, may be allocated to a single UE. This is a special case of multicode transmission. All the PDSCHs are operated with radio frame synchronization.

PDSCHs allocated to the same UE on different radio frames may have different spreading factors.

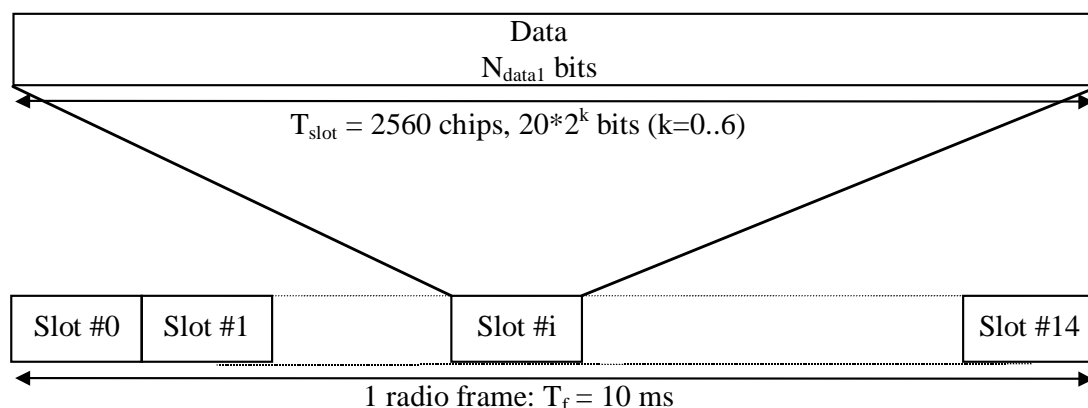

Figure 5.13: Frame structure of PDSCH

For each radio frame, each PDSCH is associated with one downlink DPCH. The PDSCH and associated DPCH do not necessarily have the same spreading factors and are not necessarily frame aligned.

All relevant Layer 1 control information is transmitted on the DPCH part of the associated DPCH, i.e. the PDSCH does not carry Layer 1 information. To indicate for UE that there is data to decode on the DSCH, the TFCI field of the associated DPCH shall be used.

The TFCI informs the UE of the instantaneous transport format parameters related to the PDSCH as well as the channelization code of the PDSCH.

For PDSCH the allowed spreading factors may vary from 256 to 4.

5.3.1.2.7 Acquisition Indicator CHannel (AICH)

The Acquisition Indicator channel (AICH) is a fixed rate ($SF = 256$) physical channel used to carry Acquisition Indicators (AI). Acquisition Indicator AI_s corresponds to signature s on the PRACH.

The AICH consists of a repeated sequence of 15 consecutive *access slots* (AS), each of length 5 120 chips. Each access slot consists of two parts, an *Acquisition-Indicator* (AI) part consisting of 32 real-valued symbols a_0, \dots, a_{31} and a part of duration 1 024 chips with no transmission that is not formally part of the AICH. The part of the slot with no transmission is reserved for possible use by CSICH or possible future use by other physical channels.

The spreading factor (SF) used for channelization of the AICH is 256.

The phase reference for the AICH is the Primary CPICH.

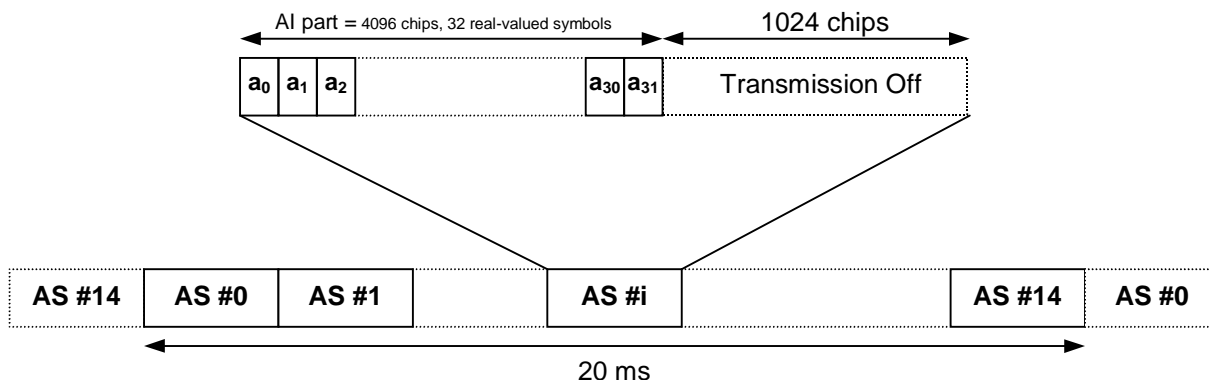

Figure 5.14: Structure of AICH

5.3.1.2.8 CPCH Access Preamble Acquisition Indicator CHannel (AP-AICH)

The Access Preamble Acquisition Indicator channel (AP-AICH) is a fixed rate (SF = 256) physical channel used to carry AP acquisition indicators (API) of CPCH. AP acquisition indicator API_s corresponds to AP signature s transmitted by UE.

AP-AICH and AICH may use the same or different channelization codes. The phase reference for the AP-AICH is the Primary CPICH. The AP-AICH has a part of duration 4 096 chips where the AP acquisition indicator (API) is transmitted, followed by a part of duration 1 024 chips with no transmission that is not formally part of the AP-AICH. The part of the slot with no transmission is reserved for possible use by CSICH or possible future use by other physical channels.

The spreading factor (SF) used for channelization of the AP-AICH is 256.

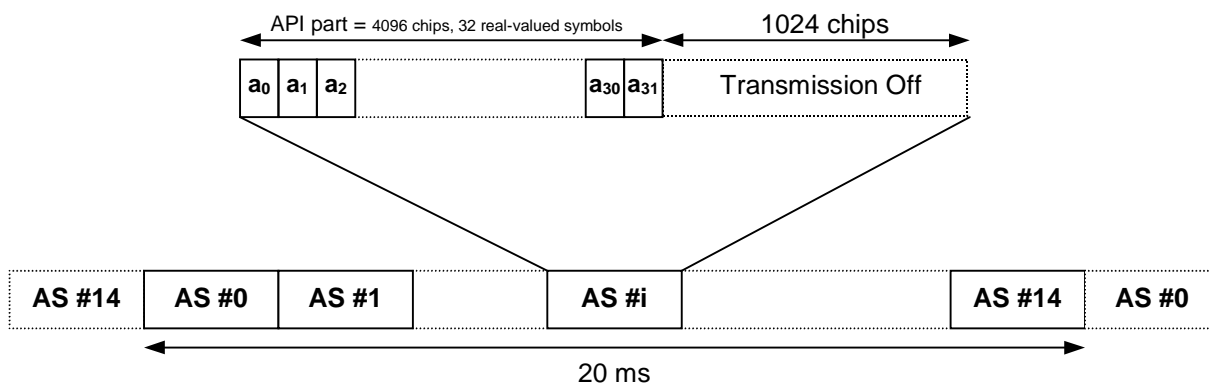

Figure 5.15: Structure of AP-AICH

5.3.1.2.9 CPCH Collision Detection/CHannel Assignment Indicator CHannel (CD/CA-ICH)

The Collision Detection CHannel Assignment Indicator channel (CD/CA-ICH) is a fixed rate (SF = 256) physical channel used to carry CD Indicator (CDI) only if the CA is not active, or CD Indicator/CA Indicator (CDI/CAI) at the same time if the CA is active. CD/CA-ICH and AP-AICH may use the same or different channelization codes.

The CD/CA-ICH has a part of duration of 4 096 chips where the CDI/CAI is transmitted, followed by a part of duration 1 024 chips with no transmission that is not formally part of the CD/CA-ICH. The part of the slot with no transmission is reserved for possible use by CSICH or possible future use by other physical channels.

The spreading factor (SF) used for channelization of the CD/CA-ICH is 256.

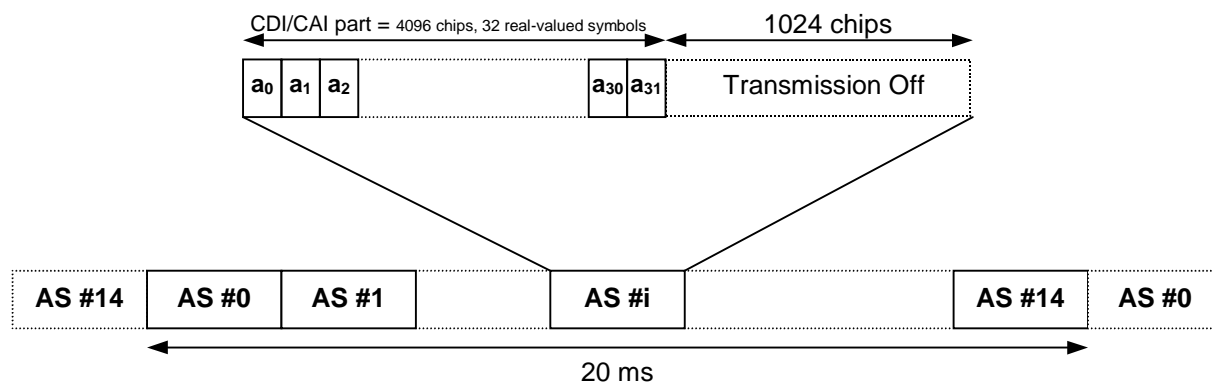

Figure 5.16: Structure of CD/CA-ICH

5.3.1.2.10 CPCH Status Indicator CHannel (CSICH)

The CPCH Status Indicator CHannel (CSICH) is a fixed rate ($SF = 256$) physical channel used to carry CPCH status information.

A CSICH is always associated with a physical channel used for transmission of CPCH AP-AICH and uses the same channelization and scrambling codes. The CSICH frame consists of 15 consecutive access slots (AS) each of length 40 bits. Each access slot consists of two parts, a part of duration 4 096 chips with no transmission that is not formally part of the CSICH, and a Status Indicator (SI) part consisting of 8 bits b_{8i}, \dots, b_{8i+7} , where i is the access slot number. The part of the slot with no transmission is reserved for use by AICH, AP-AICH or CD/CA-ICH. The modulation used by the CSICH is the same as for the PICH. The phase reference for the CSICH is the Primary CPICH.

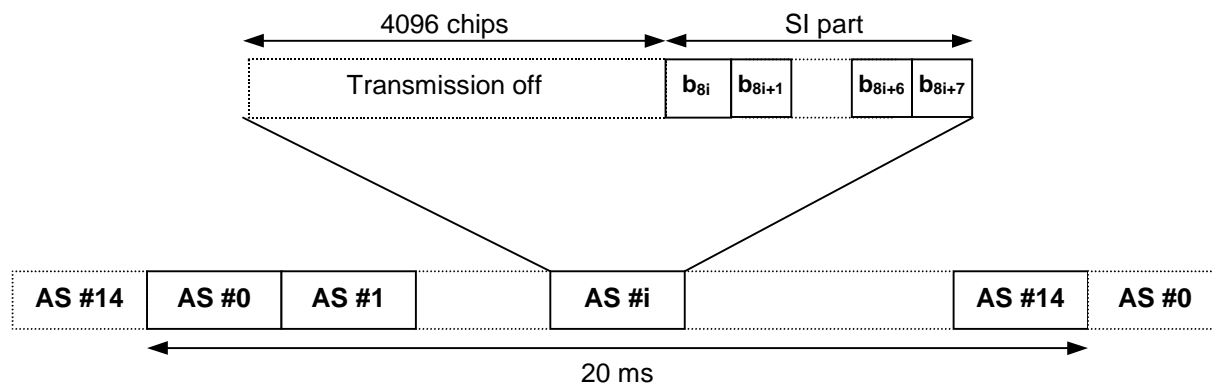

Figure 5.17: Structure of CSICH

5.3.1.3 Spreading and modulation

Data modulation is QPSK where each pair of two bits are serial-to-parallel converted and mapped to the I and Q branch respectively. The I and Q branch are then spread to the chip rate with the same channelization code c_{ch} and subsequently scrambled by the same spot specific scrambling code c_{scramb} .

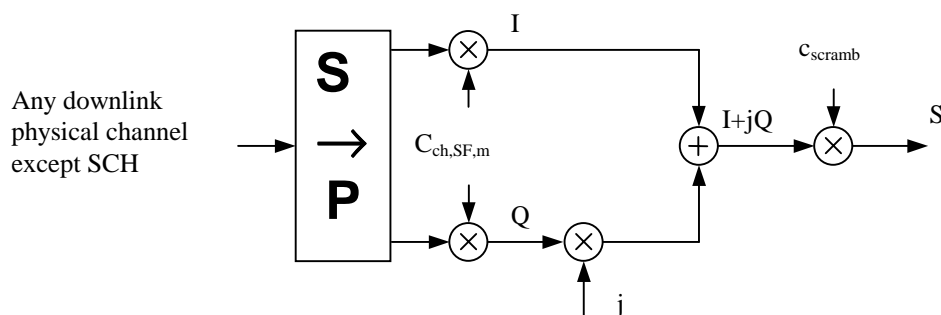

Figure 5.18: Spreading for all downlink physical channels except SCH

Figure 5.19 illustrates how different downlink channels are combined. Each complex-valued spread channel, corresponding to point S in Figure 5.18, is separately weighted by a weight factor G_i . The complex-valued P-SCH and S-SCH are separately weighted by weight factors G_p and G_s . All downlink physical channels are then combined using complex addition.

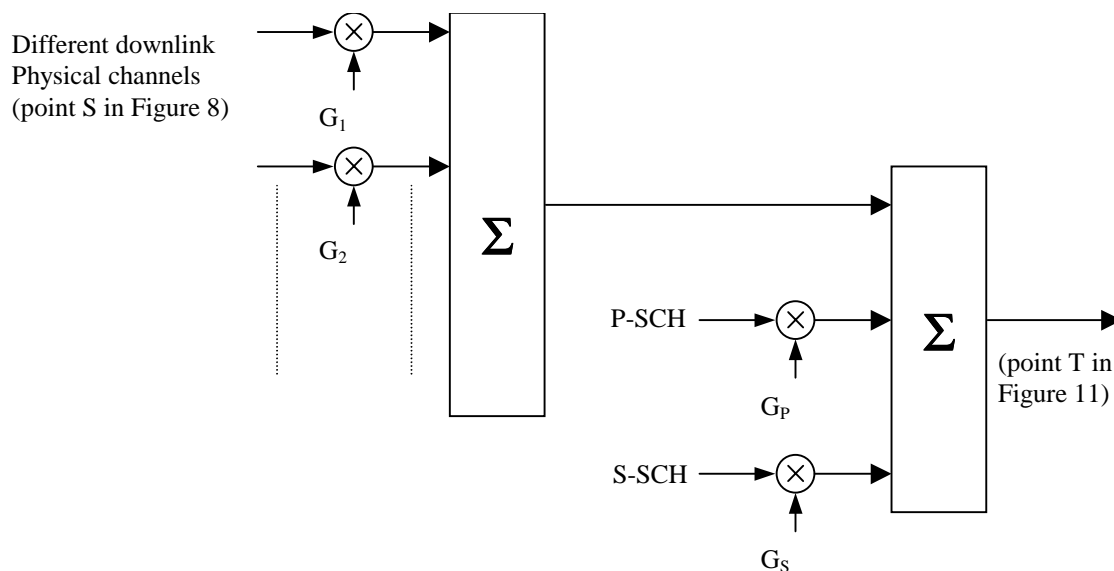

Figure 5.19: Downlink channels combination and Spreading for SCH

For multi-code transmission, each additional DPDCH/DPCCH should be assigned its own channelization code.

The channelization codes are Orthogonal Variable Spreading Factor (OVSF) codes that preserve the orthogonality between downlink channels of different rates and spreading factors. The OVSF codes can be defined using the code tree of Figure 5.20.

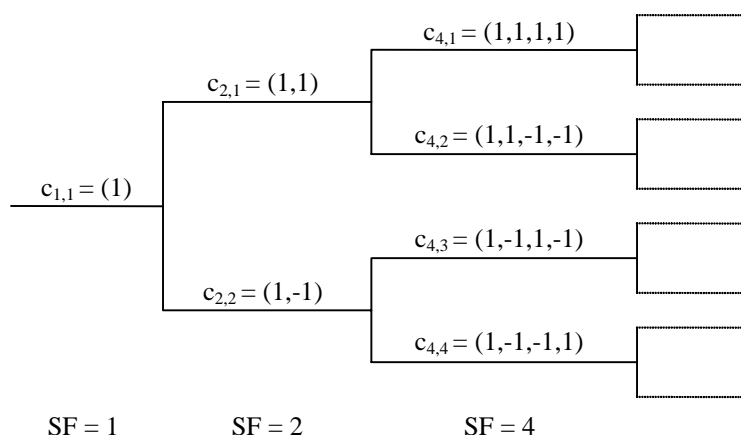

Figure 5.20: Code-tree for generation of OVFS codes

Each level in the code tree defines channelization codes of length SF, corresponding to a spreading factor of SF. All codes within the code tree cannot be used simultaneously within one spot. A code can be used in a spot if and only if no other code on the path from the specific code to the root of the tree or in the sub-tree below the specific code is used in the same spot. This means that the number of available channelization codes is not fixed but depends on the rate and spreading factor of each physical channel.

The downlink scrambling code c_{scramb} is a 38 400 chips (10 ms) segment of a length $2^{18}-1$ Gold code repeated in each frame. The scrambling codes are divided into 512 sets each of a primary scrambling code and 15 secondary scrambling codes.

The grouping of the downlink codes is done in order to facilitate a fast spot search.

The modulating chip rate is 3,84 Mcps. The pulse-shaping filters are root raised cosine (RRC) with roll-off $\alpha = 0,22$ in the frequency domain.

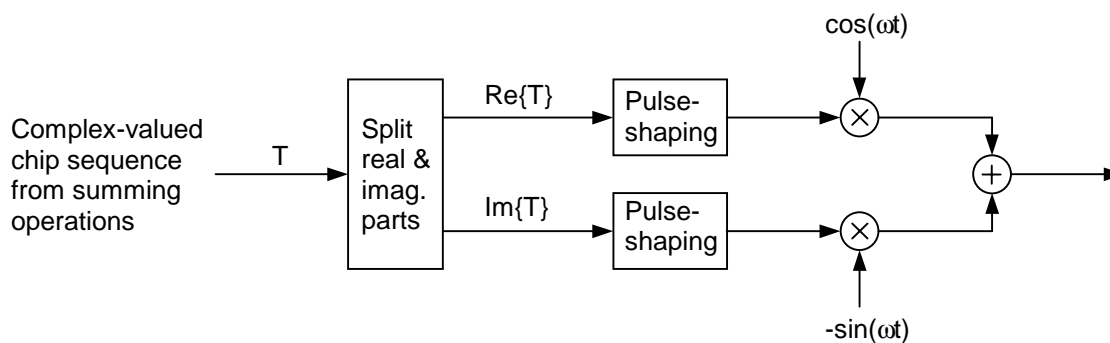

Figure 5.21: Downlink modulation

The same synchronization codes as for 3GPP UTRAN are used.

5.3.2 Uplink Physical channels

5.3.2.1 Uplink dedicated physical channels

For the uplink, the DPDCH and the DPCCH are I/Q code multiplexed within each radio frame and transmitted with dual-channel QPSK modulation. Each additional DPDCHs is code multiplexed on either the I- or the Q-branch with this first channel pair.

5.3.2.1.1 Frame structure

Figure 5.22 shows the principle of frame structure of the uplink dedicated physical channels. Each frame of length 10 ms is split into 15 slots, each of length $T_{\text{slot}} = 0,666$ ms (2 560 chips), corresponding to one power-control period. Within each slot, the DPDCH and the DPCCH are transmitted in parallel.

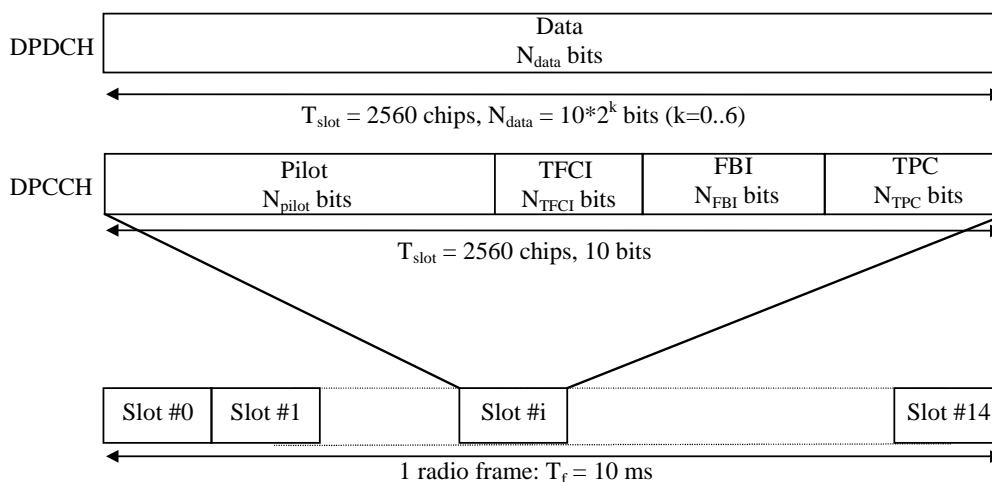

Figure 5.22: Frame structure for uplink dedicated physical channels

The parameter k in Figure 5.22 determines the number of bits per DPDCH slot. It is related to the spreading factor SF of the physical channel as $SF = 256 / 2^k$. The spreading factor may range from 256 down to 4. The spreading factor of the uplink DPCCH is always equal to 256, i.e. there are 10 bits per uplink DPCCH slot.

The exact number of bits of the uplink DPDCH is depending on the transport format, and the different uplink DPCCH fields (N_{pilot} , N_{TFCI} , N_{FBI} , and N_{TPC}) are depending on the slot format. What slot format to use is configured by higher layers and can also be reconfigured by higher layers. The FBI bits are used to support techniques requiring feedback from the UE to the USRAN Access Point, including closed loop mode transmit diversity and Spot Selection Diversity Transmission (SSDT). Applicability of those techniques to the satellite environment is addressed in clause 5.5.

Power control periods do not match fast fading correction due to satellite propagation time. Nevertheless, slot structure is kept unchanged in order to reduce modification requirements of terrestrial UE and Node B modems. Configuration and use of TPC bits in satellite environment is detailed in clause 5.5.5.

72 consecutive uplink frames constitute one W-CDMA super frame of length 720 ms.

5.3.2.1.2 Spreading and modulation

The DPCCH is spread to the chip rate by the channelization code c_c , while the n :th DPDCH called DPDCH_n is spread to the chip rate by the channelization code $c_{d,n}$. One DPCCH and up to six parallel DPDCHs can be transmitted simultaneously, i.e. $1 \leq n \leq 6$.

After channelization, the real-valued spread signals are weighted by gain factors, β_c for DPCCH and β_d for all DPDCHs.

After the weighting, the stream of real-valued chips on the I- and Q-branches are summed. This complex-valued signal is then scrambled by the complex-valued scrambling code $S_{\text{dpcch},n}$.

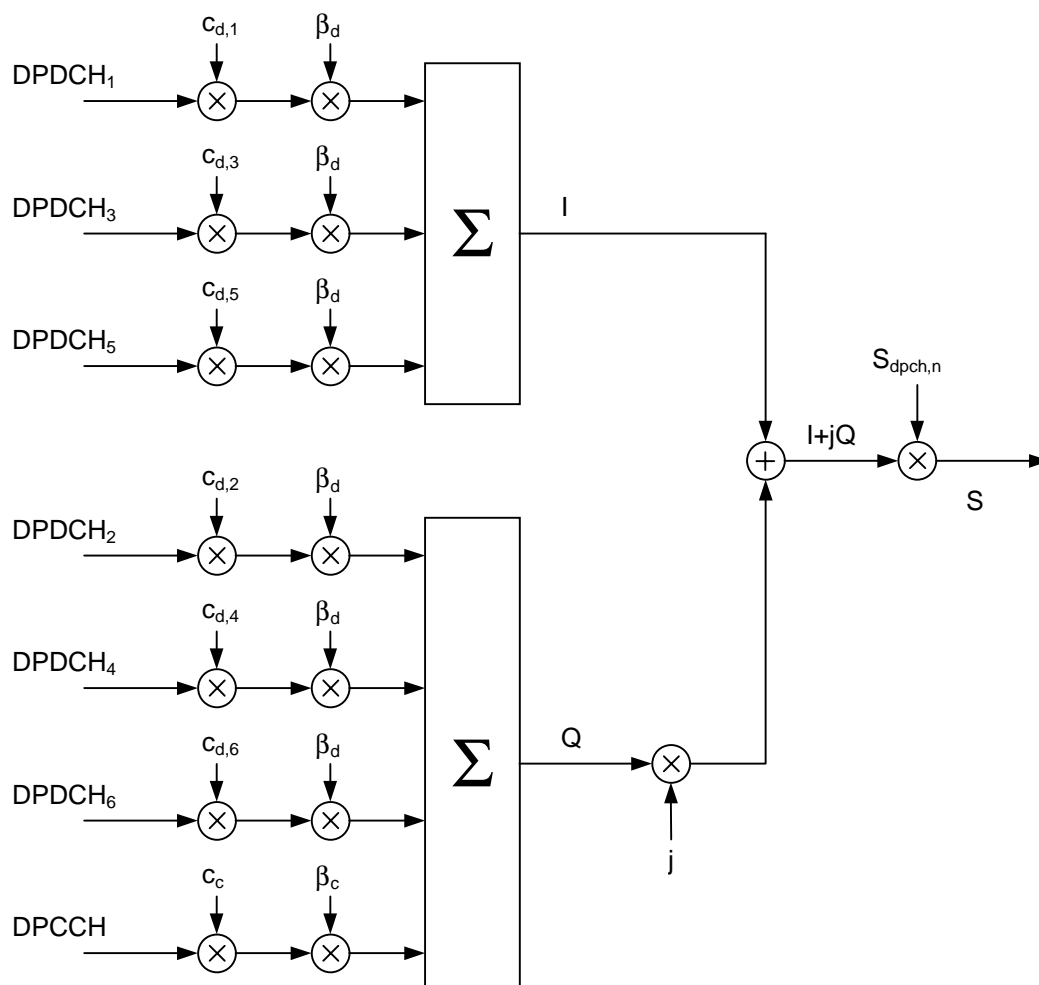

Figure 5.23: Spreading for uplink dedicated physical channels

The channelization codes of Figure 5.23 are the same type of OVSF codes as for the downlink. (For the uplink, the restrictions on the allocation of channelization codes are only valid within one mobile station. → to be confirmed).

The DPCCH/DPDCH may be scrambled by either long or short scrambling codes.

Data modulation is QPSK. The modulating chip rate is 3,84 Mcps. The pulse-shaping filters are root-raised cosine (RRC) with roll-off $\alpha = 0,22$ in the frequency domain.

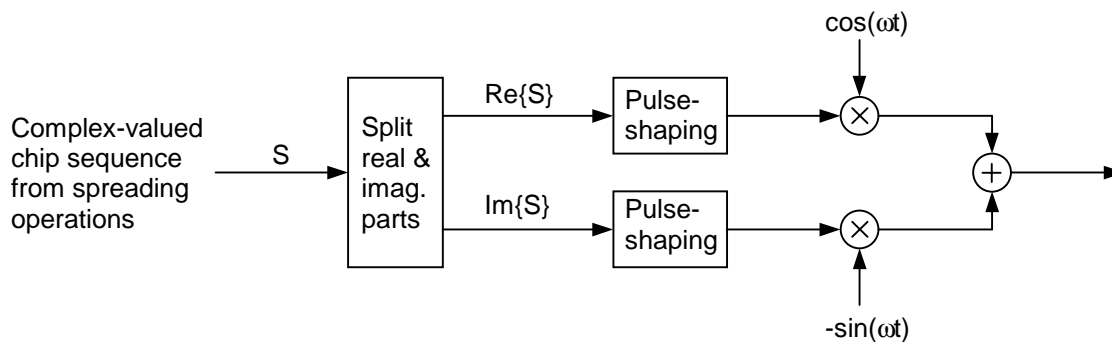

Figure 5.24: Uplink modulation

5.3.2.2 Physical Random Access CHannel (PRACH)

5.3.2.2.1 Overall structure of random-access transmission

The random-access transmission is based on a Slotted ALOHA approach with fast acquisition indication. The UE can start the random-access transmission at the beginning of a number of well-defined time intervals, denoted *access slots*. There are 15 access slots per two frames and they are spaced 5 120 chips apart.

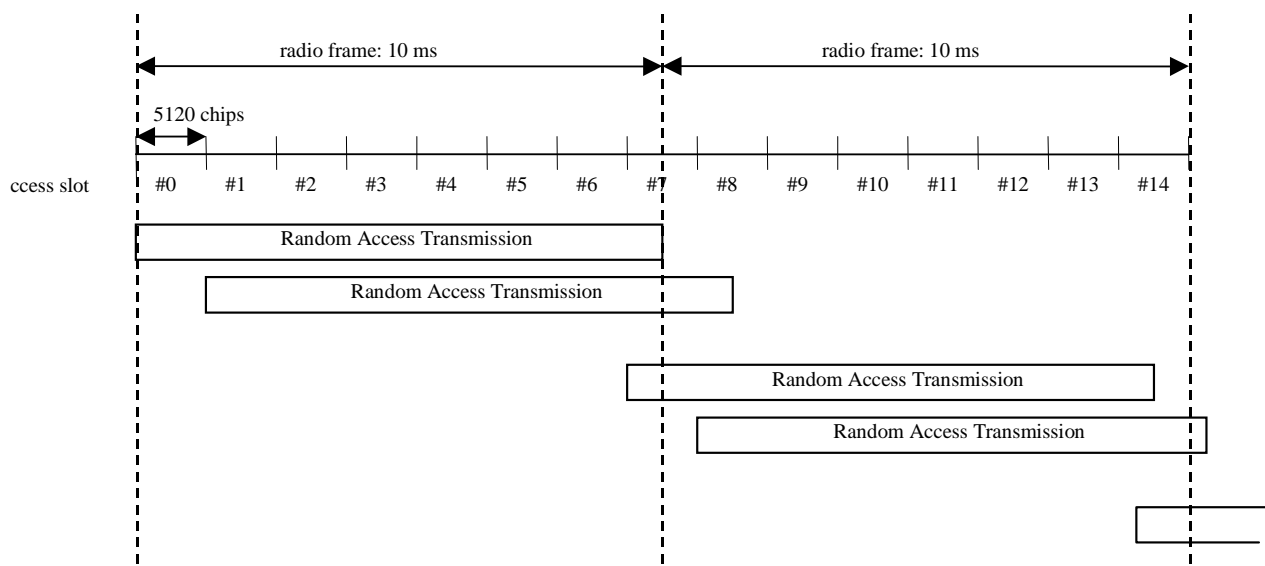

Figure 5.25: RACH access slot numbers and their spacing

The random-access transmission consists of one or several *preambles* of length 4 096 chips and a *message* of length 10 ms or 20 ms.

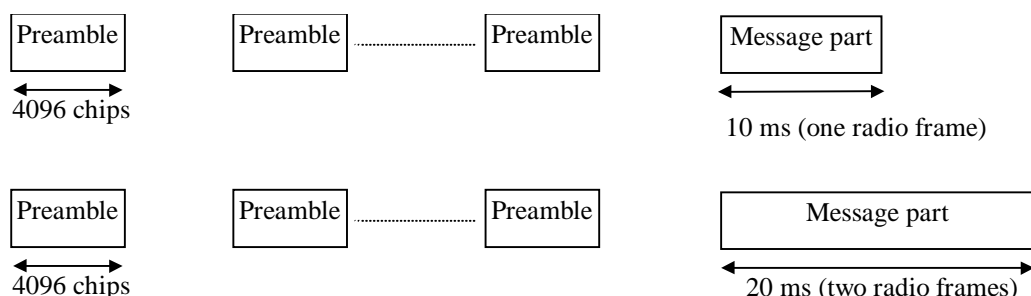

Figure 5.26: Structure of the random-access transmission

5.3.2.2.2 PRACH preamble part

Each preamble is of length 4 096 chips and consists of 256 repetitions of a signature of length 16 chips.

5.3.2.2.3 PRACH message part

The 10 ms message part radio frame is split into 15 slots, each of length $T_{\text{slot}} = 2\,560$ chips. Each slot consists of two parts, a data part to which the RACH transport channel is mapped and a control part that carries Layer 1 control information. The data and control parts are transmitted in parallel. A 10 ms message part consists of one message part radio frame, while a 20 ms message part consists of two consecutive 10 ms message part radio frames. The message part length is equal to the Transmission Time Interval of the RACH Transport channel in use.

The data part consists of 10×2^k bits, where $k = 0, 1, 2, 3$. This corresponds to a spreading factor of 256, 128, 64, and 32 respectively for the message data part.

The control part consists of 8 known pilot bits to support channel estimation for coherent detection and 2 TFCI bits. This corresponds to a spreading factor of 256 for the message control part. The total number of TFCI bits in the random-access message is $15 \times 2 = 30$. The TFCI of a radio frame indicates the transport format of the RACH transport channel mapped to the simultaneously transmitted message part radio frame. In case of a 20 ms PRACH message part, the TFCI is repeated in the second radio frame.

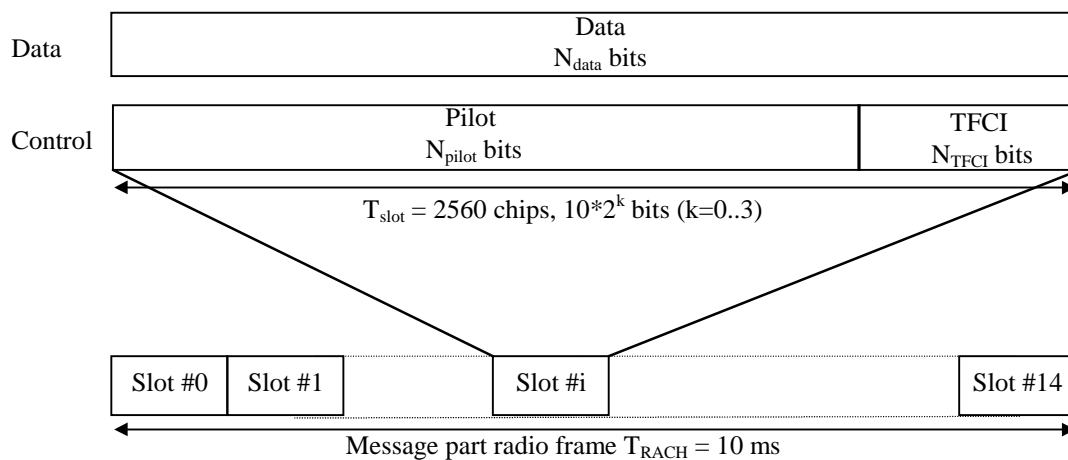

Figure 5.27: Structure of the random-access message part radio frame

5.3.2.3 Physical Common Packet CHannel (PCPCH)

5.3.2.3.1 CPCH transmission

The CPCH transmission is based on DSMA-CD approach with fast acquisition indication. The UE can start transmission at the beginning of a number of well-defined time-intervals, relative to the frame boundary of the received BCH of the current spot. The access slot timing and structure is identical to RACH. The PCPCH access transmission consists of one or several Access Preambles [A-P] of length 4 096 chips, one Collision Detection Preamble (CD-P) of length 4 096 chips, a DPCCH Power Control Preamble (PC-P) which is either 0 slots or 8 slots in length, and a message of variable length $N \times 10$ ms.

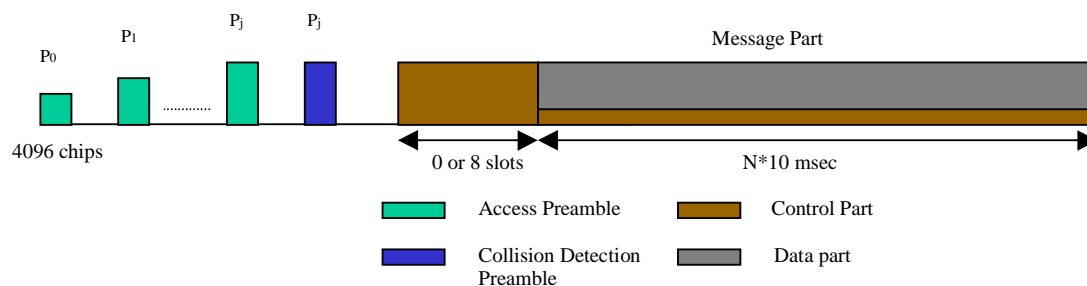

Figure 5.28: Structure of the CPCH access transmission

5.3.2.3.2 CPCH access preamble part

Similar to RACH preamble part. The RACH preamble signature sequences are used. The number of sequences used could be less than the ones used in the RACH preamble. The scrambling code could either be chosen to be a different code segment of the Gold code used to form the scrambling code of the RACH preambles or could be the same scrambling code in case the signature set is shared.

5.3.2.3.3 CPCH collision detection preamble part

Similar to RACH preamble part. The RACH preamble signature sequences are used. The scrambling code is chosen to be a different code segment of the Gold code used to form the scrambling code for the RACH and CPCH preambles.

5.3.2.3.4 CPCH power control preamble part

The power control preamble segment is called the CPCH Power Control Preamble (PC-P) part. The Power Control Preamble length shall take the value 0 or 8 slots.

5.3.2.3.5 CPCH message part

Each message consists of up to N_Max_frames 10 ms frames. Each 10 ms frame is split into 15 slots, each of length $T_{slot} = 2\,560$ chips, corresponding to one power-control period. Each slot consists of two parts, a data part that carries higher layer information and a control part that carries Layer 1 control information. The data and control parts are transmitted in parallel.

The spreading factor for the control part of the CPCH message part is 256.

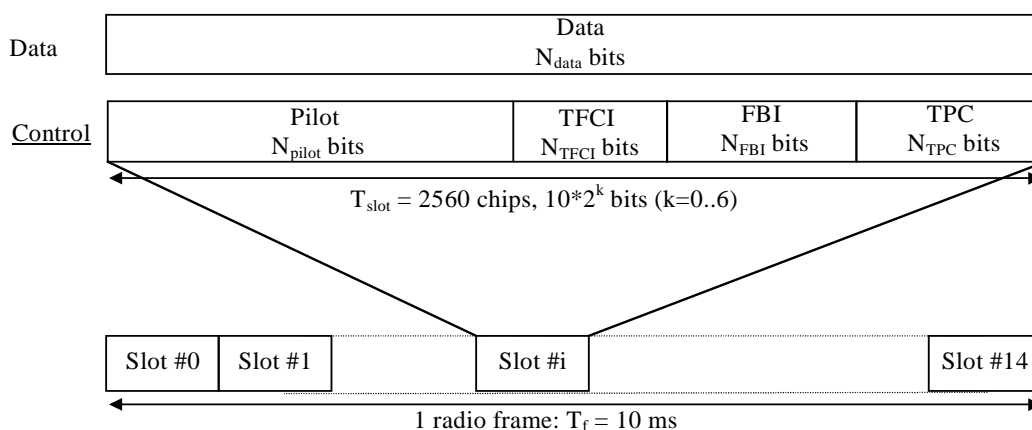

Figure 5.29: Frame structure for uplink Data and Control Parts Associated with PCPCH

The data part consists of 10×2^k bits, where $k = 0, 1, 2, 3, 4, 5, 6$, corresponding to spreading factors of 256, 128, 64, 32, 16, 8, 4 respectively.

5.4 Channel coding and service multiplexing

5.4.1 Channel coding/interleaving for user services

W-CDMA offers three basic service classes with respect to forward-error-correction (FEC) coding [14]:

- standard-services with convolutional coding;
- high-quality services with Turbo coding;
- services with service-specific coding, i.e. services for which the W-CDMA layer 1 does not apply any pre-specified channel coding.

Data arrives to the coding/multiplexing unit in form of transport block sets once every transmission time interval. The transmission time interval is transport-channel specific from the set {10 ms, 20 ms, 40 ms, and 80 ms}.

The following coding/multiplexing steps are defined [14]:

- add CRC to each transport block;
- transport block concatenation and code block segmentation;
- channel coding;
- radio frame equalization;
- rate matching;
- insertion of discontinuous transmission (DTX) indication bits;
- interleaving (two steps);
- radio frame segmentation;
- multiplexing of transport channels;
- physical channel segmentation;
- mapping to physical channels.

5.4.1.1 CRC attachment

Error detection is provided on transport blocks through a Cyclic Redundancy Check (CRC). The size of the CRC is 24, 16, 12, 8 or 0 bits.

5.4.1.2 Transport block concatenation and code block segmentation

All transport blocks in a TTI are serially concatenated. If the number of bits in a TTI is larger than Z , the maximum size of a code block in question, then code block segmentation is performed after the concatenation of the transport blocks. The maximum size of the code blocks depends on whether convolutional coding, turbo coding or no coding is used.

5.4.1.3 Channel coding

The scheme of Turbo coder is a Parallel Concatenated Convolutional Code (PCCC) with two 8-state constituent encoders and one Turbo code internal interleaver.

Table 5.4: Channel coding scheme and coding rate

Type of TrCH	Coding scheme	Coding rate
BCH	Convolutional coding (constraint length 9)	1/2
PCH		
RACH		
CPCH, DCH, DSCH, FACH	Turbo coding	1/3, 1/2
	No coding	1/3

5.4.1.4 Radio frame size equalization

Radio frame size equalization is padding the input bit sequence in order to ensure that the output can be segmented in data segments of same size. Radio frame size equalization is only performed in the UL.

5.4.1.5 Radio frame segmentation

When the transmission time interval is longer than 10 ms, the input bit sequence is segmented and mapped onto consecutive radio frames. Following rate matching in the DL and radio frame size equalization in the UL the input bit sequence length is guaranteed to be an integer multiple of radio frames.

5.4.1.6 TrCH multiplexing

Every 10 ms, one radio frame from each TrCH is delivered to the TrCH multiplexing. These radio frames are serially multiplexed into a coded composite transport channel (CCTrCH).

5.4.1.7 Insertion of discontinuous transmission (DTX) indication bits

In the downlink, DTX is used to fill up the radio frame with bits. The insertion point of DTX indication bits depends on whether fixed or flexible positions of the TrCHs in the radio frame are used. It is up to the UTRAN to decide for each CCTrCH whether fixed or flexible positions are used during the connection. DTX indication bits only indicate when the transmission should be turned off, they are not transmitted.

5.4.1.8 Outer coding/interleaving

The current assumption for the outer Reed Salomon coding is a rate 4/5 code over the 2^8 -ary symbol alphabet.

After outer Reed Salomon coding, symbol-wise inter-frame block interleaving is applied.

5.4.1.9 Rate matching

After channel coding and service multiplexing, the total bit rate is almost arbitrary. The rate matching matches this rate to the limited set of possible bit rates of a Dedicated Physical Data Channel. Rate matching means that bits on a transport channel are repeated or punctured.

5.5 Radio Resource Functions

5.5.1 Initial spot search

During the initial satellite spot search, the UE searches for and determines the long code and frame synchronization of the spot to which it has the lowest path loss. This is carried out in three steps.

5.5.1.1 Step 1: Slot synchronization

During the first step of the initial spot search procedure, the UE uses the primary synchronization channel to acquire slot synchronization to the strongest spot. This is done with a matched filter matched to the primary synchronization code c_p common to all spots. The output of the matched filter, accumulated over a sufficient number of slot intervals, will give peaks for each ray of each spot within range of the UE. Detecting the position of the strongest peak gives the timing of the strongest spot modulo the slot length.

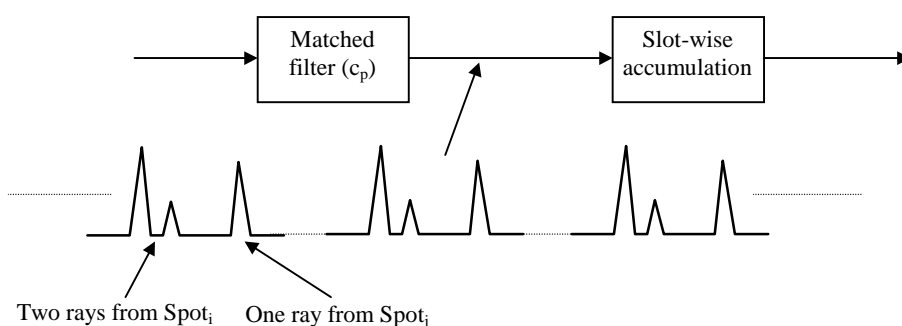

Figure 5.30: Matched-filter search for primary synchronization code

5.5.1.2 Step 2: Frame synchronization and code-group identification

During the next step of the initial spot search procedure, the UE uses the secondary synchronization channel to find frame synchronization and identify the code group of the spot found in the first step. This is done by correlating the received signal at the position of the secondary synchronization codes with all possible secondary synchronization codes. Note that the position of the Secondary synchronization codes are known after the first step, due to the known time offset between the primary and the secondary synchronization codes.

Furthermore, the frame synchronization is found from the modulation sequence of the secondary SCH.

5.5.1.3 Step 3: Scrambling-code identification

During the last step of the initial spot search procedure, the UE determines the exact primary scrambling code used by the found spot. The primary scrambling code is identified through symbol-by-symbol correlation over the CPICH with all scrambling codes within the code group identified in the second step.

After the scrambling code has been identified, the Primary CCPCH can be detected, super-frame synchronization can be acquired and the system- and spot specific BCCH information can be read.

5.5.2 Random Access procedure

5.5.2.1 3GPP inherited procedure

Before making a Random Access attempt, UEs:

- Acquire chip and frame synchronization to the target spot (initial spot search).
- Acquire information about what Random Access (preamble) codes are available in the spot from the BCCH.
- Estimate the uplink path-loss from measurements of the received spot power and use this path-loss estimate, together with the uplink received interference level and received SIR target, to decide the transmit power of the Random Access burst. The uplink interference level as well as the required received SIR are broadcast on the BCCH.

The UE then transmits the Random Access burst with a $n \times 2$ ms time-offset ($n = 0..4$) relative to the received frame boundary. The value of n , i.e. the time-offset, is chosen at random at each Random Access attempt.

UEs implement the following procedure:

- 1) Decoding of BCH and acquisition of access parameters.
- 2) Random choice of a PRACH sub-channel among the set of sub-channels allocated to the access class the UE belongs to.
- 3) Transmission of a PRACH preamble.
- 4) Decoding of AICH channel in order to test if the gateway detected the preamble.
- 5) If the preamble was not detected, re-transmission of the PRACH preamble with increase of transmit power in the next available access slot.
- 6) When AICH indicates the preamble was correctly detected by the gateway, transmission of the message part.
- 7) If the maximum number of preamble re-transmission is reached, or if the gateway signals a non acknowledgement, the Random-Access procedure is declared failed.

5.5.2.2 Adaptation to satellite environment

Random access parameters broadcast over BCH are:

- available access slots map;
- list of available signatures;
- minimum delay between 2 preambles transmission;
- acknowledgement reception delay;
- delay between preamble and message transmissions;
- maximum number of preamble repetitions;
- parameters for PRACH transmit power calculation.

5.5.2.2.1 Transmit power

One shot acquisition is commonly used in satellite environment.

3GPP W-CDMA radio interface eases one shot acquisition activation thanks to PRACH radio access parameters broadcast over BCH.

Radio access network can configure PRACH access parameters to relevant values in order to set initial preamble transmit power to maximum value (one shot acquisition). This adaptation to satellite environment and proper configuration of System Information Blocks is managed by radio resource algorithm at the gateway (RNC).

5.5.2.2.2 Power ramp up procedure

The power ramp up procedure can be easily adapted to satellite environment by configuring properly the maximum number preamble repetition UEs are allowed (configuration parameter broadcast over BCH). Configuration is done at the gateway (RNC).

5.5.2.2.3 Preamble collisions

A particular attention must be set to timing synchronization relative to access slots, due to the spot size in a satellite environment.

Time reference is broadcast by satellite and is received at UEs with a delay which is depending on their position in the spot coverage. Each UE synchronizes its time clock to the one received from the satellite, but due to UEs propagation time dispersion, UEs de-synchronization towards each other is an important outcome.

Examples of propagation time dispersion, taking into account the overall two way loop delay dispersion (from gateway to UE and from UE to gateway) for several satellite configuration types are given hereafter:

- European spot coverage, UEs elevation from 20° to 40°: in the range of 13 ms (~10 access slots).
- National spot coverage (European country size): in the range of 4 ms (~3 access slots).

A guard time is defined between access slots (1 024 chips). In a terrestrial system with coverage areas limited to few kilometres, this guard time is sufficient to absorb UEs propagation time dispersion.

Within a satellite spot coverage, UEs propagation time dispersion is larger (up to few milli-seconds). This means guard time must be enlarged. In order to keep 3GPP access slot map structure, adaptation to satellite radio environment is done via inhibition of access slots. The number of inhibited access slots is satellite constellation configuration dependant.

An illustration is given hereafter, where only 1 access slot is available for a total of 3 access slots (slots number slots 0, 3, 6, 9 and 12).

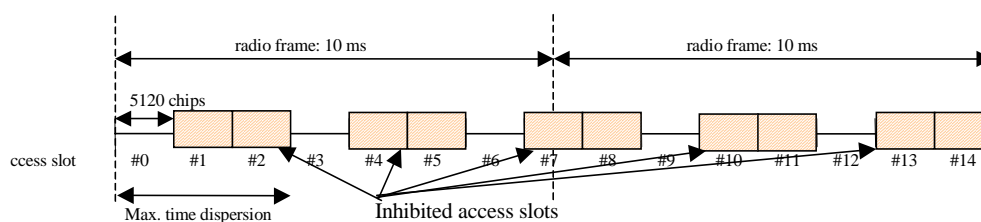

Figure 5.31: Satellite access slot mapping as broadcast over BCH

While Access Slot map broadcast over BCH indicates some access slots are inhibited, the gateway is subject to receive preambles within the inhibited access slots due to UEs time dispersion. This is illustrated in figure 5.32.

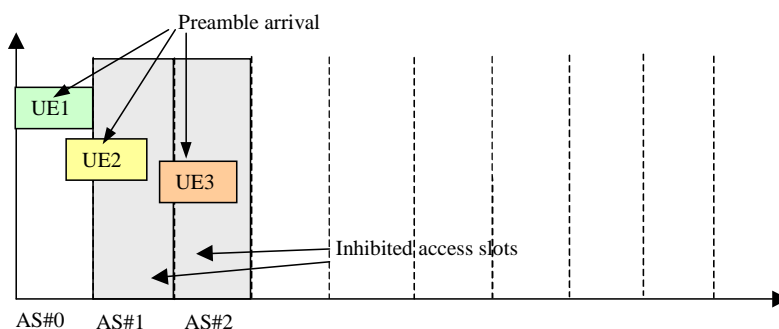

Figure 5.32: Preambles reception at the gateway

5.5.2.2.3.1 Gateway preamble acquisition

Preamble search window is adjusted to the maximum UEs time dispersion. Impact of search window size on preamble E_c/N_0 is detailed in clause 6.2.1.1 (preamble performance requirement).

Additionally, large preamble acquisition window induces drawbacks:

- Several preambles received in the same reception window are not distinguished, while there is no preambles overlapping (collision). This reduces artificially RACH capacity.
- Time for samplings storage is increased: this introduces additional processing delay in a system which is otherwise slowly reactive (due to large propagation delay).
- Processing time is increased with few possibility to manage parallel treatment.

In order to improve system efficiency, it is suggested as an option to implement several preamble reception windows per group of access slots, i.e. running also for inhibited access slots as illustrated in figure 5.33.

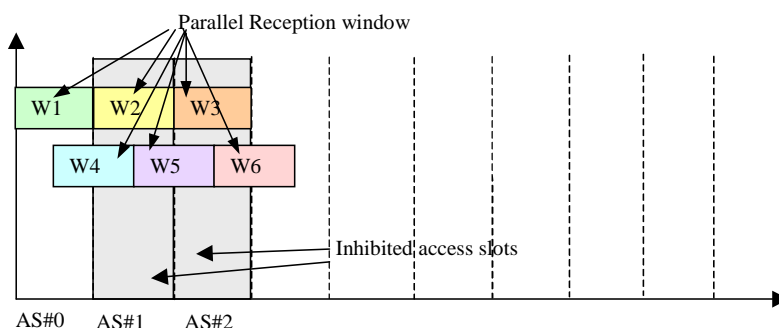

Figure 5.33: Gateway multiple preamble reception windows

5.5.2.2.3.2 UE synchronization (optional)

As an option, UE preamble transmission can be modified in order to get closer to slotted ALOHA.

Two solutions can be envisaged:

- UE transmission timing is corrected with GNSS reference so that preamble reception within one access slot is guaranteed. This requires UE is equipped with a GNSS device.
- UE repeats preambles with a time shift chosen according to an algorithm configured with the spot size. Several transmissions are tried until to cope with gateway preamble acquisition window. A major drawback of this solution is time for preamble acquisition is considerably increased due to multiple preamble re-transmissions.

5.5.2.2.4 AICH

3GPP standards set preamble-to-AI distance τ_{p-a} in relation with terrestrial propagation delays, which is restricted to 2 values: 7 680 chips and 12 800 chips (2 ms and 3,33 ms) . This does not fit with satellite channel latency.

Thus it is required to adapt UE AICH reception window in order to cope with satellite propagation delay: UE implements τ_{p-a} with a multiplication factor and AICH reception window is time shifted to be compared to 3GPP terrestrial procedure. The multiplication factor is satellite constellation dependant.

5.5.2.2.5 Message part reception

When gateway has sent positive acknowledgement over AICH, it must prepare RACH message part reception after a delay compatible with satellite channel latency. The reception delay is satellite constellation dependant.

5.5.3 Code allocation

Scrambling and channelization codes are allocated in the same manner than TS 125 213 [15].

When IMRs are deployed, IMR downlink scrambling codes are allocated according to two strategies:

- "Multi-path mode": a unique scrambling code for the whole spot coverage, i.e. the same scrambling code is used for MSS satellite and every IMR transmission under the same spot coverage. This case takes advantage of the UE receiver capability for multi-path combining.
- "Macro-diversity mode": one scrambling code per Tx equipment, i.e. one for the MSS satellite transmission and one scrambling code per IMR or group of IMRs. This case takes advantage of the UE receiver capability for multi-downlink scrambling code combining. IMR scrambling codes can be re-used between far away areas (downlink scrambling codes limitation).

5.5.4 Void

5.5.5 Power control

5.5.5.1 Open-loop power control

Open-loop power control is used to adjust the transmit power of the physical Random-Access channel. Before the transmission of a Random-Access frame, the UE should measure the received power of the downlink Primary Common Control Physical Channel over a sufficiently long time to remove any effect of the non-reciprocal multi-path fading. From the power estimate and knowledge of the Primary CCPCH transmit power (broadcast on the BCCH) the downlink path-loss including shadow fading can be found. From this path loss estimate and knowledge of the uplink interference level and the required received SIR, the transmit power of the physical Random-Access channel can be determined. The uplink interference level as well as the required received SIR is broadcast on the BCCH.

5.5.5.2 Layer 1 closed loop power control

Layer 1 closed loop power control similar to 3GPP may be envisaged, i.e. generating one Transmit Power Control command per slot. Nevertheless, due to satellite channel latency, 3GPP layer 1 closed loop power control is to be adapted.

The delay to reach the receiver is in the range of 240 ms for GSO satellite, i.e. if applied immediately TPC commands do not match fast fading correction and furthermore are destructive.

Thus, in order to counteract the slow reactivity of the satellite link and to avoid oscillation loops, several methods are envisaged:

- The processing of TPC commands is adapted to satellite environment: the receiver averages TPC commands over several slots (several frames) before to apply. This is similar to 3GPP Algorithm 2 [16], with a filtering period extended from 5 slot to several frames. The averaging period is to be adapted according to satellite constellation type (LEO, MEO, HEO, GEO).
- Mechanization of the inner and outer loop [42].
- Layer 1 closed loop power control inhibition.

In order to limit terrestrial UE and Node B modems modifications, 3GPP slot structure is kept unchanged, i.e. TPC commands are transmitted once per slot. In case layer 1 closed loop power control is inhibited, power allocated to TPC bits can be configured to low value.

5.5.5.2.1 Number of TPC commands per frame

Due to propagation delay inherent to satellite systems, it is recommended to reduce the number of TPC commands per frame in order to avoid over-sampling and loop instabilities.

TS 125 214 [16] defines the parameter `DPC_MODE`, controlled by RRC in the link establishment setup message. It allows to configure the radio link so that TPC can be repeated over several slots. Actually, 3GPP defines two values: 0 (1 TPC per slot) or 1 (1 TPC repeated over 3 slots). It is proposed to extend this value to at least 15 slots, which means 1 TPC per frame.

With that configuration, 1 TPC repeated over 15 slots, the receiver executes only 1 command per frame, which means reduction of the TPC rate for avoiding power oscillations is reached.

Capacity loss due to TPC overhead (significant only for low data rate services, up to 10 % for downlink DPCH SF = 256) can be reduced by adjusting power offset applied to TPC, i.e. PO2 (configured by network RRC at link establishment).

5.5.5.2.2 Mechanization of the inner and outer loop

Performances were evaluated for LEO constellation. See [42].

5.5.5.2.3 Layer 1 closed loop power control inhibition

Layer 1 closed loop power control inhibition is done via radio link configuration.

5.5.5.2.3.1 Uplink

The gateway (RNC/RRC) configures radio link with 3GPP algorithm 2 [16], i.e. UE processes received TPC commands on a 5-slot cycle.

As specified in [16], the value of TPC_cmd is derived as follows:

- For the first 4 slots of a set, TPC_cmd = 0.
- For the fifth slot of a set, the UE uses hard decisions on each of the 5 received TPC commands as follows:
 - If all 5 hard decisions within a set are 1 then TPC_cmd = 1 in the 5th slot.
 - If all 5 hard decisions within a set are 0 then TPC_cmd = -1 in the 5th slot.
- Otherwise, TPC_cmd = 0 in the 5th slot.

Node B transmits an alternating series of TPC commands, so that UE always interprets 5th slot TPC command as TPC_cmd = 0 thus the UE transmit power is kept constant.

An alternative solution is UE does not execute any TPC command whatever the radio link configuration. This solution is UE capability dependent (i.e. UE modem modified for satellite access or not).

5.5.5.2.3.2 Downlink

Downlink layer 1 power control is inhibited via Iub RADIO LINK SETUP REQUEST message, i.e. Inner Loop DL PC Status I.E. is set to *Inactive* [31].

5.5.5.3 Uplink Slow closed loop power control

Uplink slow closed loop power control is operated at layer 3 level (RRC).

5.5.5.3.1 Initial transmit power

At DCH establishment, UE DPCCH initial transmit power is calculated as:

$$\text{DPCCH_Initial_power} = \text{DPCCH_Power_offset} - \text{CPICH_RSCP}$$

CPICH RSCP is measured by the UE. DPCCH Power offset is configured by RAN and sent to UE in the CHANNEL SETUP message at dedicated channel establishment.

Gateway (RNC) is able to control DPCCH initial transmit power thanks to the possibility to configure UE for reporting CPICH RSCP measurement at initial UE uplink access (connection request).

The reporting quantity is configured by the gateway for the whole spot coverage and is broadcast over BCH. 3GPP standard allows for 3 measurement quantities [24]:

- CPICH Ec/N0; or
- CPICH RSCP; or
- Path loss.

UE derives the DPDCH initial transmit power from Gain Factors β_c / β_d which are signalled to UE in the CHANNEL SETUP message.

5.5.5.3.2 Transmit power reconfiguration

After DCH establishment, UE transmit power is controlled by the gateway based on uplink reception quality measurements and UE measurement reports.

Upon decision to modify uplink transmit power, the gateway initiates a physical channel reconfiguration, keeping unchanged all the radio link parameters excepted transmit power parameters, i.e. DPCCH Power offset and gain factors β_c and β_d .

The UE measurement report quantities are configured by the gateway at channel establishment. The ones used for uplink slow closed power control are:

- UE Transmitted Power;
- CPICH RSCP.

CPICH measurement report can be stored by RRC UE in order to correct transmit power command from the gateway according to CPICH RSCP updated measurement at reception of physical channel reconfiguration message. The gateway is informed about the UE transmit power really applied with the physical channel reconfiguration completion message.

5.5.5.4 Downlink Slow closed loop power control

Downlink slow closed loop power control is operated at layer 3 level (RRC).

5.5.5.4.1 Initial transmit power

Initial satellite transmit power is calculated with the CPICH RSCP measurement report transmitted by UE to the gateway in the connection request message.

5.5.5.4.2 Transmit power adjustment

The gateway adjusts satellite downlink transmission power based on USRA Carrier RSSI and quality measurement UE reports and on uplink quality measurements.

The UE measurement report quantities are configured by the gateway at channel establishment. The ones used for downlink slow closed power control are:

- USRA Carrier RSSI;
- Quality Measurement.

5.5.6 Handover

5.5.6.1 Intra-frequency handover

5.5.6.1.1 Soft handover

Soft handover is applicable in case of either:

- Intra-satellite spots coverage overlapping (single satellite system).
- Inter-satellite spots coverage overlapping (multi satellites system).

When in active mode, the UE continuously searches for new spots on the current carrier frequency. This spot search is carried out in basically the same way as the initial spot search. The main difference compared to the initial spot search is that an UE station has received a priority list from the network. This priority list describes in which order the downlink scrambling codes should be searched for and does thus significantly reduce the time and effort needed for the scrambling-code search (step 3). The priority list is continuously updated to reflect the changing neighbourhood of a moving UE.

During the search, the UE measures the received signal level broadcast from neighbouring spot, compares them to a set of thresholds, and reports them accordingly back to the gateway (RNC). Based on this information the network orders the UE to add or remove spot links from its *active set*. The *active set* is defined as the set of spots from which the same user information is sent, simultaneously demodulated and coherently combined.

From the spot-search procedure, the UE knows the frame offset of the CCPCH of potential soft-handover candidates relative to that of the source spot(s) (the spots currently within the active set). When a soft handover is to take place, this offset together with the frame offset between the DPDCH/DPCCH and the Primary CCPCH of the source spot, is used to calculate the required frame offset between the DPDCH/DPCCH and the Primary CCPCH of the destination spot (the spot to be added to the active set). This offset is chosen so that the frame offset between the DPDCH/DPCCH of the source and destination spots at the UE receiver is minimized. Note that the offset between the DPDCH/DPCCH and Primary CCPCH can only be adjusted in steps of one DPDCH/DPCCH symbol in order to preserve downlink orthogonality.

5.5.6.1.2 Softer handover

Softer handover is the special case of a soft handover between sectors/spots belonging to the same gateway (Node B) site. Conceptually, a softer handover is initiated and executed in the same way as an ordinary soft handover. The main differences are on the implementation level within the network. For softer handover, it is e.g. more feasible to do uplink maximum-ratio combining instead of selection combining as the combining is done on the Node B level rather than on the RNC level.

5.5.6.2 Inter-frequency handover

In W-CDMA the vast majority of handovers are within one carrier frequency, i.e. intra-frequency handover. Inter-frequency handover may typically occur in the following situations:

- Handover between spots to which different number of carriers have been allocated, e.g. due to different capacity requirements (hot-spot scenarios).
- Handover between spots of different overlapping orthogonal spot layers using different carrier frequencies.
- Handover between different operators/systems using different carrier frequencies including handover to terrestrial UMTS/GSM.

A key requirement for the support of seamless inter-frequency handover is the possibility for the UE to carry out spot search on a carrier frequency different from the current one, without affecting the ordinary data flow. W-CDMA supports inter-frequency spot search in two different ways, a dual-receiver approach and a slotted-downlink-transmission approach.

5.5.6.2.1 Dual-receiver

For a UE with receiver diversity, there is a possibility for one of the receiver branches to temporarily be reallocated from diversity reception and instead carry out reception on a different carrier.

5.5.6.2.2 Slotted downlink transmission

With slotted downlink transmission, it is possible for a single-receiver UE to carry out measurements on other frequencies without affecting the ordinary data flow. When in slotted mode, the information normally transmitted during a 10 ms frame is compressed in time, either by code puncturing or by reducing the spreading factor by a factor of 2. In this way, an idle time period of up to 5 ms is created within each frame. During that time, the UE receiver is idle and can be used for inter-frequency measurements.

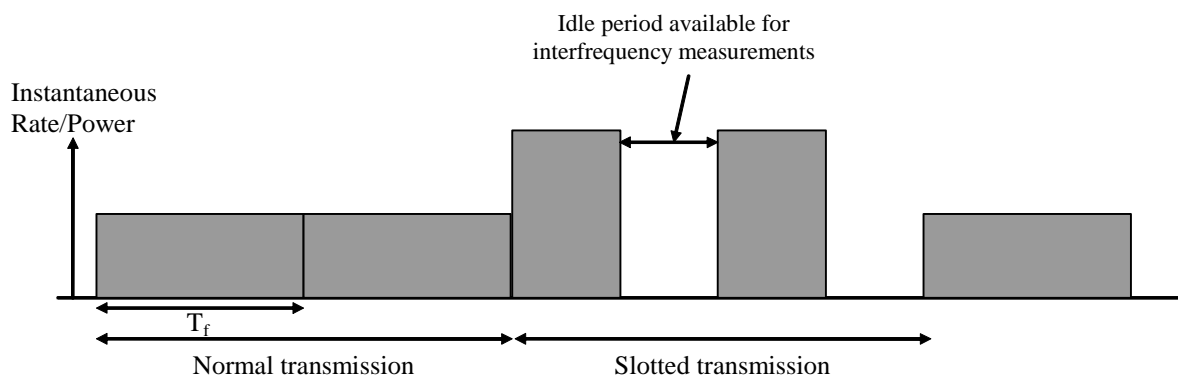

Figure 5.34: Downlink slotted transmission

5.5.7 Spot Selection Transmit Diversity

Spot Selection Transmit Diversity (SSTD) is a macro diversity method operable in soft handover mode. It is activated/deactivated by RRC signalling.

The UE selects one of the spots from its active set to be "primary", all other spots are classed as "non primary". UE periodically reports measurements to the gateway it is attached to, i.e. it reports the primary spot ID by using FBI field in uplink DPCCH.

Transmit power of non primary spots is set to OFF, which switch OFF spot transmit power.

This method allows to transmit on the downlink only from spot selected by UE, thus reducing the interference caused by multiple transmissions in a soft handover mode. It also allows to achieve fast spot selection without higher layers intervention, thus maintaining the advantage of soft handover.

5.6 W-CDMA Packet Access

Due to the varying characteristics of packet data traffic in terms of packet size and packet intensity, a dual-mode packet-transmission scheme is used for W-CDMA. With this scheme, packet transmission can either take place on a common fixed-rate channel or on a dedicated channel.

5.6.1 Common-channel packet transmission

In this mode, an uplink packet is appended directly to a Random-Access burst. Common-channel packet transmission is typically used for short infrequent packets, where the link maintenance needed for a dedicated channel would lead to unacceptable overhead. Also the delay associated with a transfer to a dedicated channel is avoided. Note that, for common-channel packet transmission, only open-loop power control is in operation. Common-channel packet transmission should therefore be limited to short packets that only use a limited amount of capacity.

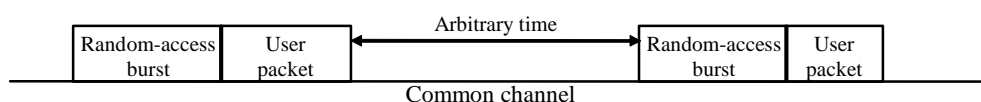

Figure 5.35: Packet transmission on common channel

5.6.2 Dedicated-channel packet transmission

In this mode, an initial Random-Access request is used to set up a dedicated channel for the packet transmission. On this dedicated channel, closed-loop power control is in operation. The dedicated channel can either be set up for the transmission of a single packet or for the transmission of a sequence of packets (multi-packet transmission).

5.6.2.1 Single-packet transmission

Single-packet transmission is typically used for the transmission of large infrequent packets. For single-packet transmission on a dedicated channel, the initial Random-Access request includes the amount of data to be transmitted. The network may respond to the access request in two different ways:

- With a short acknowledgement. A scheduling message is then sent to the mobile station at the time when the actual packet transmission can start. The scheduling message includes the transfer format, e.g. the bit rate, to be used for the packet transmission.
- With an immediate scheduling message, that either allows for immediate packet transmission, or that indicates at what time in the (near) future the mobile station may start its transmission.

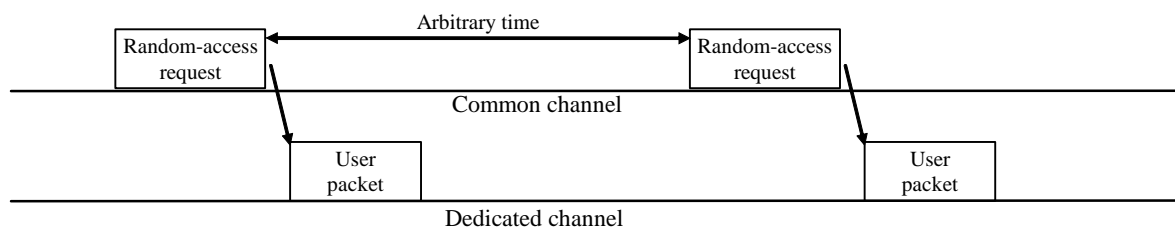

Figure 5.36: Single-packet transmission on dedicated channel

5.6.2.2 Multi-packet transmission

For multi-packet transmission on a dedicated channel an initial Random-Access request is used to set up a dedicated packet channel. On this channel, short packets may be transmitted without any scheduling, similar to the common-channel packet transmission. Larger packets may require that an access request is first sent by the mobile station on the dedicated channel. The network responds to this request in the same way as for the single-packet case.

- With a short acknowledgement. A scheduling message is then sent to the mobile station at the time when the actual packet transmission can start. The scheduling message includes the transfer format, e.g. the bit rate, to be used for the packet transmission.
- With an immediate scheduling message, that either allows for immediate packet transmission, or that indicates at what time in the (near) future the mobile station may start its transmission.

The link maintenance consists of power-control commands and pilot symbols needed to preserve power control and synchronization of the dedicated physical channel.

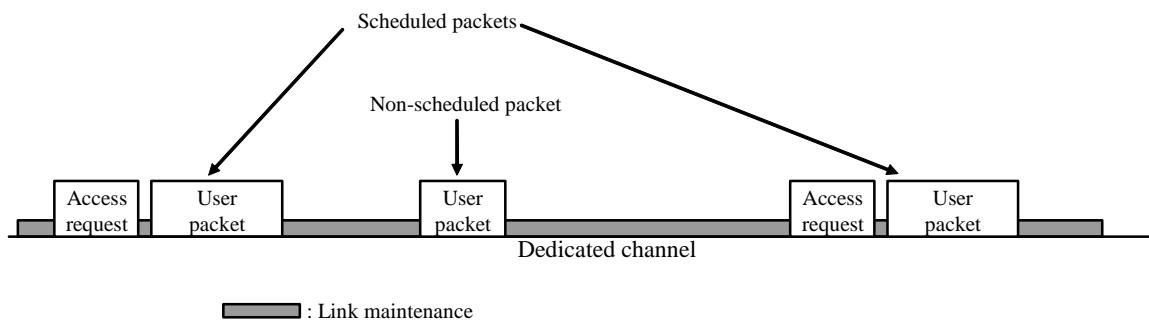

Figure 5.37: Multi-packet transmission on dedicated channel

5.7 Support of TDD

For further release.

6 Performance requirements

6.1 Test environment support

6.1.1 Satellite environments

UEs operate in either LOS or NLOS propagation conditions, i.e. either Rice or Rayleigh propagation channel.

Path blockage can be induced by heavy shadowing from hills, trees, bridges and buildings. The car body (vehicular UE configuration) and the head of the user (handset UE configuration) can also have a non-negligible impact. Tree shadowing can lead to 10 dB - 20 dB of excess attenuation and is often the cause for link outage.

The useful dynamic range for the received signal power is much smaller than for terrestrial environments (for which it goes up to 80 dB). This is due to the different system geometry (reduced path loss variation within each satellite beam, in the order of 3 dB - 5 dB) and to the limited satellite/UE RF power which is insufficient to counteract path blockage.

Multi-path diversity in a single satellite system results in paths in the range of -20 dB below the main path. Multi-paths are exploited by Rake receiver. Link level simulation results presented hereafter show the impact of these multi-paths on radio link performance.

In case the system is composed of more than one satellite, satellite diversity can be provided, including soft handover capability. Radio channels can benefit from this for link outage reduction and quality of service improvement.

ITU Satellite channel tap models from 0 are hereafter adopted.

Table 6.1: Channel model A (10 % delay spread values); Rural

Tap number	Relative tap delay value (ns)	Tap amplitude distribution	Parameter of amplitude distribution (dB)	Average amplitude with respect to free space propagation	Rice factor (dB)	Doppler spectrum
1	0	LOS: Rice NLOS: Rayleigh	$10 \log c$ $10 \log P_m$	0,0 -7,3	10 -	Rice Classic
2	100	Rayleigh	$10 \log P_m$	-23,6	-	Classic
3	180	Rayleigh	$10 \log P_m$	-28,1	-	Classic

Table 6.2: Channel model B (50 % delay spread values); Sub-urban

Tap number	Relative tap delay value (ns)	Tap amplitude distribution	Parameter of amplitude distribution (dB)	Average amplitude with respect to free space propagation	Rice factor (dB)	Doppler spectrum
1	0	LOS: Rice NLOS: Rayleigh	$10 \log c$ $10 \log P_m$	0,0 -9,5	7 -	Rice Classic
2	100	Rayleigh	$10 \log P_m$	-24,1	-	Classic
3	250	Rayleigh	$10 \log P_m$	-25,1	-	Classic

Table 6.3: Channel model C (90 % delay spread values); Urban

Tap number	Relative tap delay value (ns)	Tap amplitude distribution	Parameter of amplitude distribution (dB)	Average amplitude with respect to free space propagation	Rice factor (dB)	Doppler spectrum
1	0	LOS: Rice NLOS: Rayleigh	$10 \log c$ $10 \log P_m$	0,0 -12,1	3 -	Rice Classic
2	60	Rayleigh	$10 \log P_m$	-17,0	-	Classic
3	100	Rayleigh	$10 \log P_m$	-18,3	-	Classic
4	130	Rayleigh	$10 \log P_m$	-19,1	-	Classic
5	250	Rayleigh	$10 \log P_m$	-22,1	-	Classic

6.1.2 Intermediate Module Repeater environment

When UEs are on view of IMRs only (no view of the satellite signal), radio environment is terrestrial, i.e. propagation conditions apply as they are specified by TS 125 101 [10].

6.1.3 Combined Satellite and IMR environment

When UEs are on view of both IMRs and satellite signals, IMRs introduce artificial multi-paths. The satellite and IMR paths are to be added to the rake receiver fingers set.

Satin project proposed propagation models that apply to combined satellite and IMR environment [39] and [40] for the downlink. They are based on two IMR configurations:

- low power IMR: the cell radius is 400 m;
- high power IMR: the cell radius is 2 km.

In both cases, IMR taken as a reference is surrounded by 6 IMRs, with a regular hexagonal cellular layout. The distance of the UE from the reference IMR is $0,87 \times$ cell radius. The path delay profiles extracted from [40] are depicted hereafter.

Table 6.4: Path delay profile; Low power IMR

Sat		Ref. IMR		IMR1		IMR2	
Relative Delay (μ s)	Avg. Power (dB)	Relative Delay (μ s)	Avg. Power (dB)	Relative Delay (μ s)	Avg. Power (dB)	Relative Delay (μ s)	Avg. Power (dB)
0,00	-3,8	1,99	0,0	0,32	-3,7	2,44	-13,2
		2,30	-1,0	0,63	-4,7	2,75	-14,2
		2,70	-9,0	1,03	-12,7	3,15	-22,2
		3,08	-10,0	1,41	-13,7	3,53	-23,2
		3,72	-15,0	2,05	-18,7	4,17	-28,2
		4,50	-20,0	2,83	-23,7	4,95	-33,2
IMR3		IMR4		IMR5		IMR6	
Relative Delay (μ s)	Avg. Power (dB)	Relative Delay (μ s)	Avg. Power (dB)	Relative Delay (μ s)	Avg. Power (dB)	Relative Delay (μ s)	Avg. Power (dB)
5,18	-17,5	6,16	-17,5	4,41	-13,2	1,30	-3,7
5,49	-18,5	6,47	-18,5	4,72	-14,2	1,61	-4,7
5,89	-26,5	6,87	-26,5	5,12	-22,2	2,01	-12,7
6,27	-27,5	7,25	-27,5	5,50	-23,2	2,39	-13,7
6,91	-32,5	7,89	-32,5	6,14	-28,2	3,03	-18,7
7,69	-37,5	8,67	-37,5	6,92	-33,2	3,81	-23,7

Table 6.5: Path delay profile; High power IMR

Sat		Ref IMR		IMR1		IMR2	
Relative Delay (μ s)	Avg. Power (dB)	Relative Delay (μ s)	Avg. Power (dB)	Relative Delay (μ s)	Avg. Power (dB)	Relative Delay (μ s)	Avg. Power (dB)
0,00	-6,5	9,96	0,0	1,58	-3,7	1,58	-3,7
		10,27	-1,0	1,89	-4,7	1,89	-4,7
		10,67	-9,0	2,29	-12,7	2,29	-12,7
		11,05	-10,0	2,67	-13,7	2,67	-13,7
		11,69	-15,0	3,31	-18,7	3,31	-18,7
		12,47	-20,0	4,09	-23,7	4,09	-23,7
IMR3		IMR4		IMR5		IMR6	
Relative Delay (μ s)	Avg. Power (dB)	Relative Delay (μ s)	Avg. Power (dB)	Relative Delay (μ s)	Avg. Power (dB)	Relative Delay (μ s)	Avg. Power (dB)
25,91	-17,5	30,83	-17,5	22,04	-13,2	6,50	25,91
26,22	-18,5	31,14	-18,5	22,35	-14,2	6,81	26,22
26,62	-26,5	31,54	-26,5	22,75	-22,2	7,21	26,62
27,00	-27,5	31,92	-27,5	23,13	-23,2	7,59	27,00
27,64	-32,5	32,56	-32,5	23,77	-28,2	8,23	27,64
28,42	-37,5	33,34	-37,5	24,55	-33,2	9,01	28,42

Satin project proposed a set of propagation conditions for defining performance test cases inspired by those of 3GPP specifications, taking into account the presence of IMRs and of the direct path from satellite. The test propagation conditions extracted from [39] are depicted hereafter.

Table 6.6: Path delay profiles; Satellite test cases

S-Case 1 speed 3 km/h		S-Case 2 speed 3 km/h		S-Case 3 speed 120 km/h		S-Case 4 speed 250 km/h		S-Case 5 speed 120 km/h		S-Case 6 speed 250 km/h	
Relative Delay [ns]	Average Power [dB]	Relative Delay [ns]	Average Power [dB]	Relative Delay [ns]	Average Power [dB]	Relative Delay [ns]	Average Power [dB]	Relative Delay [ns]	Average Power [dB]	Relative Delay [ns]	Average Power [dB]
0	0	0	0	0	0	0	0	0	-3	0	-3
1 042	-10	1 042	0	260	-3	260	-3	260	-3	260	-3
		26 563	0	521	-6	521	-6	521	-9	521	-9
				781	-9	781	-9	1 042	-3	1 042	-3
								1 302	-3	1 302	-3
								1 562	-3	1 562	-3
								1 823	0	1 823	0
								2 083	0	2 083	0

Note that for case 5 and case 6, tap at 0 ns is Rice distributed.

6.1.4 Aeronautical environment

Aeronautical environment is derived from [43] for a speed of 800 km/h.

Table 6.7: Channel model; Aeronautical; 800 km/h

Tap number	Relative delay (ns)	Average power (dB)	Rice factor (dB)	Doppler spectrum
1	0	0	14	Rice
2	11 500	-18	-	Classic

6.2 Expected performances

Link level simulations have been run for the test environments described above in order to specify the receiver performance requirements. All the results apply to a Block Error Ratio (BLER) of 10^{-2} .

6.2.1 Performance requirement for RACH

6.2.1.1 Preamble detection

The requirements are specified for a Probability of false alarm Pfa (false detection of the preamble when the preamble was not sent) less than 10^{-3} and a probability of detection Pd more than 0,99. Only 1 signature is used and it is known by the receiver.

Table 6.8: Ec/No preamble requirement

Environment	Speed	Ec/No for Pd ≥ 0,99	
AWGN	0 km/h	-23,6 dB	
ITU Model A		LOS	/ NLOS
	3 km/h	-22 dB	/ -12,5 dB
	50 km/h	-23 dB	/ -19,5 dB
	120 km/h	-23,5 dB	/ -19 dB
ITU Model B	200 km/h	-23,5 dB	/ -18,5 dB
	3 km/h	-21,5 dB	/ -12,5 dB
	50 km/h	-22,5 dB	/ -19,5 dB
	120 km/h	-23 dB	/ -19 dB
ITU Model C	200 km/h	-23 dB	/ -18 dB
	3 km/h	-20 dB	/ -11,5 dB
	50 km/h	-21 dB	/ -19 dB
	120 km/h	-21,5 dB	/ -18 dB
	200 km/h	-21,5 dB	/ -17,5 dB

6.2.1.2 Demodulation of RACH message

Table 6.9: RACH requirement for BLER = 10^{-2}

Environment	Speed	168 bits , TTI = 20 ms		360 bits, TTI = 20 ms	
AWGN	0 km/h	6,4 dB		5,9 dB	
Aeronautic	800 km/h	7,4 dB		6,8 dB	
S-Case 1	3 km/h	17,5 dB		17,1 dB	
S-Case 2	3 km/h	13,4 dB		13,1 dB	
S-Case 3	120 km/h	9 dB		8,3 dB	
S-Case 4	250 km/h	10,1 dB		9,4 dB	
S-Case 5	120 km/h	8,9 dB		8,2 dB	
S-Case 6	250 km/h	10,5 dB		9,8 dB	
ITU channels		LOS	/ NLOS	LOS	/ NLOS
Model A (rural)	3 km/h	7,5 dB	/ 19,9 dB	6,8 dB	/ 19,5 dB
	50 km/h	7,5 dB	/ 12,1 dB	6,9 dB	/ 11,5 dB
	120 km/h	7,5 dB	/ 10,2 dB	6,9 dB	/ 9,8 dB
	250 km/h	7,6 dB	/ 11,2 dB	7 dB	/ 10,7 dB
Model B (sub-urban)	3 km/h	7,8 dB	/ 18,6 dB	7,2 dB	/ 18,2 dB
	50 km/h	7,8 dB	/ 11,7 dB	7,2 dB	/ 11,1 dB
	120 km/h	7,7 dB	/ 10 dB	7,2 dB	/ 9,6 dB
	250 km/h	7,8 dB	/ 11 dB	7,3 dB	/ 10,5 dB
Model C (urban)	3 km/h	8,6 dB	/ 16,4 dB	8,1 dB	/ 16,1 dB
	50 km/h	8,7 dB	/ 10,4 dB	8,1 dB	/ 9,9 dB
	120 km/h	8,7 dB	/ 9,3 dB	8,2 dB	/ 8,8 dB
	250 km/h	8,7 dB	/ 10,4 dB	8,2 dB	/ 9,7 dB
IMR deployment		Low Power	/ High Power	Low Power	/ High Power
	3 km/h	11,5 dB	/ 12 dB	10,8 dB	/ 11,3 dB
	50 km/h	9,6 dB	/ 10,1 dB	8,9 dB	/ 9,2 dB
	120 km/h	9,7 dB	/ 10,1 dB	8,8 dB	/ 9,1 dB
	250 km/h	11,2 dB	/ 11,4 dB	10,2 dB	/ 10,6 dB

6.2.2 FACH demodulation requirements

FACH receiver performance requirements specified in TR 102 277 [35] apply.

6.2.3 Downlink DCH demodulation requirements

6.2.3.1 Summary of test measurement services

Test reference measurement channel for Tests n°1 and 2 are detailed in annex A. They apply to:

- Test 1: low data rate services, i.e. GMES data collection, SMS, etc.
- Test 2: 3GPP standardized AMR 4,75 kbit/s codec.

Reference measurement channels for the test services n° 3 to 6 are extracted from TS 125 101 [10].

Table 6.10: Reference measurement channels - Downlink

Parameter	DCH for DTCH/DCCH						Unit
	1	2	3	4	5	6	
Test number	1	2	3	4	5	6	
Information bit rate	1,2/0	4,75/0,75	12,2/2,5	64/2,5	144/2,5	384/2,5	kbps
Physical channel	7,5	15	30	120	240	480	ksps
Repetition/Puncturing rate	-16,67	-26,61	-14,7	2,9	-2,7	-22	%
Time Transmission Interval	20/-	20/40	20/40	20/40	20/40	10/40	ms
Type of Error Protection	Convolution/ Convolution	Convolution/ Convolution	Convolution/ Convolution	Turbo/ Convolution	Turbo/ Convolution	Turbo/ Convolution	-
Coding Rate	1/3	1/3	1/3	1/3	1/3	1/3	-
Size of CRC	16/-	16/12	16/12	16/12	16/12	16/12	Bit
Slot Format #i	0	5	11	13	14	15	
Power offsets PO1, PO2, PO3	0						dB
TFCI	On						
Closed loop power control	Off						

The CPICH must cover the entire spot area. Thus the CPICH power is adjusted in order a UE in the worst case position is able to correctly receive it. The same applies to the SCH, the P-CCPCH and the PICH.

The worst case UE position is considered as being the border of the lower spot elevation (16°).

The required power at UE receiver input is deduced from the physical common channels characteristics defined for the reception of the 4 test services as defined in TS 134 121 [28].

Table 6.11: Power at UE receiver input; Common physical channels

Physical Channel	Ec/Ior Power	Power at UE receiver input
P-CPICH	P-CPICH_Ec/Ior = -10 dB	-71 dBm
P-CCPCH	P-CCPCH_Ec/Ior = -12 dB	-73 dBm
SCH	SCH_Ec/Ior = -12 dB	-73 dBm
PICH	PICH_Ec/Ior = -15 dB	-76 dBm

6.2.3.2 Margins

Link level simulations have been run for the test environments and services described above in order to specify the DCH receiver performance requirements.

The tables in next clauses include margin in order to take into account effects that are not modelled in simulations (imperfect channel estimation and path search, over sampling, number of floating points, and all UE hardware margin).

The results apply to a Block Error Ratio (BLER) of 10⁻².

Table 6.12: Margin applied to Downlink DCH performance

Channel	Margin	Note
AWGN	2 dB	
Case 1, Case 2 S-Case 1, S-Case 2	2,5 dB	Slow fading
Case 3,... Case 6 S-Case 3, ... S-Case 6	3 dB	Fast fading
Aeronautical	4 dB	LOS
Other channels: 3 km/h, 50 km/h 120 km/h, 250 km/h	2,5 dB 3 dB	Slow fading Fast fading

6.2.3.3 Demodulation in static conditions

Performance requirements from TS 125 101 [10] and TS 134 121 [28] apply.

Table 6.13: DCH requirements in static conditions - Downlink

Data rate	$\frac{DPCH - E_c}{I_{or}}$	$\frac{E_b}{N_t}$
1,2 kbps	-24,9 dB	9,2 dB
4,75 kbps	-19,1 dB	9 dB
12,2 kbps	-16,5 dB	7,5 dB
64 kbps	-12,5 dB	4,3 dB
144 kbps	-9,5 dB	3,7 dB
384 kbps	-5,3 dB	3,7 dB

6.2.3.4 Demodulation in ITU channel model A conditions

The average $\frac{DPCH - E_c}{I_{or}}$ power ratio is specified for 2 UE locations: 20 % around spot centre and spot borders.

Empty compartments mean the service is not reachable (situations suffering from too high inter-spot interference).

Table 6.14: DCH parameters in ITU channel model A conditions

Parameter	Unit	Test 1	Test 2
Phase reference		P-CPICH	
\hat{I}_{or}/I_{oc}	dB	9	-3
I_{oc}	dBm/3,84 MHz	-60	
Information Data Rate	kbps	20 % spot centre	Spot border

Table 6.15: DCH requirements in ITU channel model A conditions - Downlink

Data rate	Speed	$\frac{DPCH - E_c}{I_{or}}$						$\frac{E_b}{N_t}$		
		$\frac{\hat{I}_{or}}{I_{oc}} = 9dB$			$\frac{\hat{I}_{or}}{I_{oc}} = -3dB$			LOS	/	NLOS
		LOS	/	NLOS	LOS	/	NLOS			
1,2 kbps	3 km/h	-33,8 dB	/	-26,2 dB	-19,9 dB	/	-21 dB	10,2 dB	/	17,8 dB
	50 km/h	-33,9 dB	/	-32,8 dB	-20,3 dB	/	-20,3 dB	10,1 dB	/	11,2 dB
	120 km/h	-33,2 dB	/	-32,2 dB	-20,1 dB	/	-18,8 dB	10,9 dB	/	11,9 dB
	250 km/h	-32,9 dB	/	-30,5 dB	-18,8 dB	/	-17,7 dB	11,2 dB	/	13,5 dB
4,75 kbps	3 km/h	-28 dB	/	-15,5 dB	-12,6 dB	/	-16 dB	10 dB	/	22,6 dB
	50 km/h	-27,9 dB	/	-23,7 dB	-13,4 dB	/	-15,9 dB	10,1 dB	/	14,4 dB
	120 km/h	-27,4 dB	/	-24 dB	-11,2 dB	/	-15,4 dB	10,7 dB	/	14 dB
	250 km/h	-27,3 dB	/	-25,1 dB	-10,3 dB	/	-15,3 dB	10,7 dB	/	13 dB
12,2 kbps	3 km/h	-25,7 dB	/	-13,1 dB	-13,7 dB	/	-1,1 dB	8,3 dB	/	20,9 dB
	50 km/h	-25,4 dB	/	-21,1 dB	-13,4 dB	/	-9,1 dB	8,6 dB	/	12,9 dB
	120 km/h	-24,6 dB	/	-21,9 dB	-12,6 dB	/	-9,9 dB	9,4 dB	/	12,1 dB
	250 km/h	-24,4 dB	/	-6 dB	-12,4 dB	/	-	9,6 dB	/	3 dB
64 kbps	3 km/h	-21,6 dB	/	-8 dB	-9,6 dB	/	-	5,2 dB	/	18,8 dB
	50 km/h	-21,6 dB	/	-16,7 dB	-9,6 dB	/	-4,7 dB	5,1 dB	/	10,1 dB
	120 km/h	-21,1 dB	/	-17,8 dB	-9,1 dB	/	-5,8 dB	5,7 dB	/	9 dB
	250 km/h	-21 dB	/	-8,1 dB	-9 dB	/	-	5,8 dB	/	18,7 dB
144 kbps	3 km/h	-18,5 dB	/	-4,7 dB	-6,5 dB	/	-	4,7 dB	/	18,6 dB
	50 km/h	-18,6 dB	/	-13,4 dB	-6,6 dB	/	-1,4 dB	4,7 dB	/	9,8 dB
	120 km/h	-18,1 dB	/	-14,6 dB	-6,1 dB	/	-2,6 dB	5,2 dB	/	8,7 dB
	250 km/h	-18 dB	/	-0,3 dB	-6 dB	/	-	5,3 dB	/	23 dB
384 kbps	3 km/h	-14 dB	/	-	-2 dB	/	-	5 dB	/	20,2 dB
	50 km/h	-14,1 dB	/	-6,5 dB	-2,1 dB	/	-	4,9 dB	/	12,5 dB
	120 km/h	-13,6 dB	/	-7,5 dB	-1,6 dB	/	-	5,4 dB	/	11,5 dB
	250 km/h	-13,5 dB	/	-	-1,5 dB	/	-	5,5 dB	/	19 dB

6.2.3.5 Demodulation in ITU channel model B conditions

The average $\frac{DPCH - E_c}{I_{or}}$ power ratio is specified for 2 UE locations: 20 % around spot centre and spot borders.

Empty compartments mean the service is not reachable (situations suffering from too high inter-spot interference).

Table 6.16: DCH parameters in ITU channel model B conditions

Parameter	Unit	Test 1	Test 2
Phase reference		P-CPICH	
\hat{I}_{or}/I_{oc}	DB	9	-3
I_{oc}	dBm/3,84 MHz	-60	
Information Data Rate	Kbps	20 % spot centre	Spot border

Table 6.17: DCH requirements in ITU channel model B conditions - Downlink

Data rate	Speed	$\frac{DPCH - E_c}{I_{or}}$						$\frac{E_b}{N_t}$		
		$\frac{\hat{I}_{or}}{I_{oc}} = 9dB$			$\frac{\hat{I}_{or}}{I_{oc}} = -3dB$			LOS	/	NLOS
		LOS	/	NLOS	LOS	/	NLOS			
1,2 kbps	3 km/h	-33,6 dB	/	-27 dB	-21,8 dB	/	-14,2 dB	10,4 dB	/	17 dB
	50 km/h	-33,6 dB	/	-32,9 dB	-21,9 dB	/	-20,8 dB	10,4 dB	/	11,1 dB
	120 km/h	-32,7 dB	/	-32,2 dB	-21,2 dB	/	-20,2 dB	11,3 dB	/	11,8 dB
	250 km/h	-32,4 dB	/	-30,5 dB	-20,9 dB	/	-18,6 dB	11,6 dB	/	13,4 dB
4,75 kbps	3 km/h	-27,6 dB	/	-16,8 dB	-3,5 dB	/	-15,6 dB	10,5 dB	/	21,2 dB
	50 km/h	-27,4 dB	/	-24 dB	-11,7 dB	/	-15,4 dB	10,6 dB	/	14 dB
	120 km/h	-26,8 dB	/	-24,3 dB	-12,1 dB	/	-14,8 dB	11,2 dB	/	13,7 dB
	250 km/h	-26,7 dB	/	-24,3 dB	-13,1 dB	/	-14,7 dB	11,3 dB	/	13,7 dB
12,2 kbps	3 km/h	-25,2 dB	/	-14,3 dB	-13,2 dB	/	-2,3 dB	8,8 dB	/	19,7 dB
	50 km/h	-24,9 dB	/	-21,3 dB	-12,9 dB	/	-9,4 dB	9,1 dB	/	12,6 dB
	120 km/h	-23,6 dB	/	-22,1 dB	-11,6 dB	/	-10,2 dB	10,4 dB	/	11,8 dB
	250 km/h	-23,4 dB	/	-5,9 dB	-11,4 dB	/	-	10,6 dB	/	3 dB
64 kbps	3 km/h	-21,1 dB	/	-9,1 dB	-9,1 dB	/	-	5,7 dB	/	17,6 dB
	50 km/h	-21,2 dB	/	-16,9 dB	-9,2 dB	/	-5 dB	5,6 dB	/	9,8 dB
	120 km/h	-20,7 dB	/	-18 dB	-8,7 dB	/	-6 dB	6,1 dB	/	8,7 dB
	250 km/h	-20,4 dB	/	-10,9 dB	-8,4 dB	/	-	6,3 dB	/	15,8 dB
144 kbps	3 km/h	-18 dB	/	-5,9 dB	-6 dB	/	-	5,3 dB	/	17,3 dB
	50 km/h	-18,1 dB	/	-13,7 dB	-6,1 dB	/	-1,8 dB	5,1 dB	/	9,5 dB
	120 km/h	-17,6 dB	/	-14,7 dB	-5,6 dB	/	-2,8 dB	5,6 dB	/	8,5 dB
	250 km/h	-17,4 dB	/	-6 dB	-5,4 dB	/	-	5,8 dB	/	17,2 dB
384 kbps	3 km/h	-13,2 dB	/	-0,5 dB	-1,2 dB	/	-	5,8 dB	/	18,5 dB
	50 km/h	-13,6 dB	/	-7 dB	-1,6 dB	/	-	5,4 dB	/	11,9 dB
	120 km/h	-13,2 dB	/	-8 dB	-1,2 dB	/	-	5,8 dB	/	10,9 dB
	250 km/h	-13 dB	/	-	-1 dB	/	-	6 dB	/	20 dB

6.2.3.6 Demodulation in ITU channel model C conditions

The average $\frac{DPCH - E_c}{I_{or}}$ power ratio is specified for 2 UE locations: 20 % around spot centre and spot borders.

Empty compartments mean the service is not reachable (situations suffering from too high inter-spot interference).

Table 6.18: DCH parameters in ITU channel model C conditions

Parameter	Unit	Test 1	Test 2
Phase reference		P-CPICH	
\hat{I}_{or}/I_{oc}	dB	9	-3
I_{oc}	dBm/3,84 MHz	-60	
Information Data Rate	kbps	20 % spot centre	Spot border

Table 6.19: DCH requirements in ITU channel model C conditions - Downlink

Data rate	Speed	$\frac{DPCH - E_c}{I_{or}}$						$\frac{E_b}{N_t}$		
		$\frac{\hat{I}_{or}}{I_{oc}} = 9dB$			$\frac{\hat{I}_{or}}{I_{oc}} = -3dB$			LOS	/	NLOS
		LOS	/	NLOS	LOS	/	NLOS			
1,2 kbps	3 km/h	-32,9 dB	/	-27,4 dB	-21,6 dB	/	-15 dB	11,1 dB	/	14,9 dB
	50 km/h	-32,8 dB	/	-31,3 dB	-21,6 dB	/	-20,9 dB	11,2 dB	/	11 dB
	120 km/h	-31,5 dB	/	-30,7 dB	-20,7 dB	/	-20,2 dB	12,5 dB	/	11,5 dB
	250 km/h	-31,3 dB	/	-29,3 dB	-20,4 dB	/	-18,6 dB	12,8 dB	/	13 dB
4,75 kbps	3 km/h	-26 dB	/	-17,7 dB	-4,8 dB	/	-14 dB	12 dB	/	18,6 dB
	50 km/h	-25,9 dB	/	-26,7 dB	-12 dB	/	-13,9 dB	12,2 dB	/	9,6 dB
	120 km/h	-24,9 dB	/	-23,5 dB	-12,4 dB	/	-13 dB	13,1 dB	/	12,8 dB
	250 km/h	-25,1 dB	/	-26 dB	-12,4 dB	/	-13,1 dB	12,9 dB	/	10,3 dB
12,2 kbps	3 km/h	-23,8 dB	/	-15,1 dB	-11,8 dB	/	-4,7 dB	10,2 dB	/	17,1 dB
	50 km/h	-23,3 dB	/	-24 dB	-11,3 dB	/	-13,6 dB	10,7 dB	/	8,2 dB
	120 km/h	-21,3 dB	/	-21,3 dB	-9,3 dB	/	-10,9 dB	12,7 dB	/	10,9 dB
	250 km/h	-21,1 dB	/	-23,4 dB	-9,2 dB	/	-13 dB	12,8 dB	/	8,8 dB
64 kbps	3 km/h	-19,7 dB	/	-9,9 dB	-7,7 dB	/	-	7,1 dB	/	15,1 dB
	50 km/h	-19,8 dB	/	-16,4 dB	-7,8 dB	/	-6 dB	6,9 dB	/	8,6 dB
	120 km/h	-19,3 dB	/	-17 dB	-7,3 dB	/	-6,6 dB	7,5 dB	/	8 dB
	250 km/h	-19 dB	/	-13,6 dB	-7 dB	/	-3,1 dB	7,7 dB	/	11,4 dB
144 kbps	3 km/h	-16,5 dB	/	-6,8 dB	-4,5 dB	/	-	6,7 dB	/	14,7 dB
	50 km/h	-16,6 dB	/	-13,1 dB	-4,7 dB	/	-2,7 dB	6,6 dB	/	8,4 dB
	120 km/h	-16,2 dB	/	-13,8 dB	-4,2 dB	/	-3,4 dB	7 dB	/	7,7 dB
	250 km/h	-16 dB	/	-10 dB	-4 dB	/	-	7,2 dB	/	11,5 dB
384 kbps	3 km/h	-10,8 dB	/	-1,6 dB	-	/	-	8,1 dB	/	15,6 dB
	50 km/h	-11,5 dB	/	-7,1 dB	-	/	-	7,5 dB	/	10,1 dB
	120 km/h	-11,3 dB	/	-7,8 dB	-	/	-	7,7 dB	/	9,4 dB
	250 km/h	-11 dB	/	-	-	/	-	8 dB	/	20,9 dB

6.2.3.7 Demodulation in IMR environment conditions (no satellite signal reception)

Performance requirements from TS 125 101 [10] and TS 134 121 [28] apply.

6.2.3.8 Demodulation in combined satellite and IMR environment conditions

Table 6.20: DCH requirements in combined satellite and IMR conditions - Downlink

Data rate	Speed	$\frac{DPCH - E_c}{I_{or}}$		$\frac{E_b}{N_t}$	
		Low power	High power	Low power	High power
1,2 kbps	3 km/h	-18,5 dB	-17,9 dB	12,1 dB	12,8 dB
	50 km/h	-19,5 dB	-19,1 dB	11,1 dB	11,6 dB
	120 km/h	-18,7 dB	-18,4 dB	11,9 dB	12,3 dB
	250 km/h	-17,6 dB	-17,6 dB	13 dB	13,1 dB
4,75 kbps	3 km/h	-11,9 dB	-11,4 dB	12,8 dB	13,2 dB
	50 km/h	-13,6 dB	-13,1 dB	11,1 dB	11,6 dB
	120 km/h	-12,8 dB	-12,5 dB	11,8 dB	12,2 dB
	250 km/h	-11,4 dB	-11,1 dB	13,2 dB	13,6 dB
12,2 kbps	3 km/h	-9,3 dB	-8,7 dB	11,2 dB	11,9 dB
	50 km/h	-11 dB	-10,6 dB	9,6 dB	9,9 dB
	120 km/h	-10,3 dB	-10 dB	10,2 dB	10,6 dB
	250 km/h	-8,9 dB	-8,6 dB	11,7 dB	11,9 dB
64 kbps	3 km/h	-4,3 dB	-3,8 dB	9 dB	9,6 dB
	50 km/h	-6,6 dB	-6,2 dB	6,7 dB	7,2 dB
	120 km/h	-6 dB	-5,8 dB	7,3 dB	7,6 dB
	250 km/h	-4,7 dB	-4,2 dB	8,7 dB	9,2 dB
144 kbps	3 km/h	-4,4 dB	-3,9 dB	8,7 dB	9,4 dB
	50 km/h	-6,6 dB	-6,3 dB	6,5 dB	7 dB
	120 km/h	-6,3 dB	-5,9 dB	6,9 dB	7,4 dB
	250 km/h	-4,9 dB	-4,6 dB	8,2 dB	8,7 dB
384 kbps	3 km/h	-0,6 dB	0 dB	9,3 dB	10,2 dB
	50 km/h	-2,4 dB	-1,9 dB	7,5 dB	8,1 dB
	120 km/h	-2,2 dB	-1,7 dB	7,7 dB	8,3 dB
	250 km/h	-0,6 dB	-0,3 dB	9,2 dB	9,7 dB

Table 6.21: DCH requirements in combined satellite and low power IMR conditions - Satin test cases - Downlink

Data rate	S-Case 1		S-Case 2		S-Case 3	
	$\frac{DPCH - E_c}{I_{or}}$	$\frac{E_b}{N_t}$	$\frac{DPCH - E_c}{I_{or}}$	$\frac{E_b}{N_t}$	$\frac{DPCH - E_c}{I_{or}}$	$\frac{E_b}{N_t}$
1,2 kbps	-27,4 dB	16,3 dB	-17,4 dB	13,4 dB	-20,3 dB	11,5 dB
4,75 kbps	-18,1 dB	19,6 dB	-9,3 dB	15,5 dB	-13,5 dB	11,9 dB
12,2 kbps	-15,3 dB	18,3 dB	-6,6 dB	14,2 dB	-11,1 dB	10,1 dB
64 kbps	-10,1 dB	16,3 dB	-1,7 dB	11,8 dB	-6,8 dB	7,2 dB
144 kbps	-6,9 dB	16 dB	-2 dB	11,6 dB	-7,7 dB	7,3 dB
384 kbps	-1,9 dB	16,7 dB	-	-	-3,7 dB	8,7 dB
Data rate	S-Case 4		S-Case 5		S-Case 6	
	$\frac{DPCH - E_c}{I_{or}}$	$\frac{E_b}{N_t}$	$\frac{DPCH - E_c}{I_{or}}$	$\frac{E_b}{N_t}$	$\frac{DPCH - E_c}{I_{or}}$	$\frac{E_b}{N_t}$
1,2 kbps	-18,8 dB	12,5 dB	-20,3 dB	11,7 dB	-17,7 dB	13 dB
4,75 kbps	-11,2 dB	14,1 dB	-13,4 dB	11,3 dB	-10,3 dB	14,4 dB
12,2 kbps	-8,6 dB	12,6 dB	-10,9 dB	9,7 dB	-7,6 dB	12,9 dB
64 kbps	-5,1 dB	8,9 dB	-6,9 dB	6,4 dB	-4,6 dB	8,8 dB
144 kbps	-6 dB	9 dB	-6,3 dB	6,9 dB	-3,9 dB	9,3 dB
384 kbps	-1,9 dB	10,5 dB	-1,6 dB	8,3 dB	-	-

6.2.3.9 Demodulation in aeronautical environment

The requirements hereafter are applicable to a velocity of 800 km/h.

The average $\frac{DPCH - E_c}{I_{or}}$ power ratio is specified for 2 UE locations: 20 % around spot centre and spot borders.

Table 6.22: DCH parameters in ITU channel model C conditions

Parameter	Unit	Test 1	Test 2
Phase reference		P-CPICH	
\hat{I}_{or}/I_{oc}	dB	9	-3
I_{oc}	dBm/3,84 MHz	-60	
Information Data Rate	kbps	20 % spot centre	Spot border

Table 6.23: DCH requirements in aeronautical conditions - Downlink

Data rate	$\frac{DPCH - E_c}{I_{or}}$		$\frac{E_b}{N_t}$
	$\frac{\hat{I}_{or}}{I_{oc}} = 9dB$	$\frac{\hat{I}_{or}}{I_{oc}} = -3dB$	
1,2 kbps	-31,7 dB	-19,7 dB	12,3 dB
4,75 kbps	-26,4 dB	-14,4 dB	11,6 dB
12,2 kbps	-23,8 dB	-11,8 dB	10,1 dB
64 kbps	-19,9 dB	-7,9 dB	6,9 dB
144 kbps	-17 dB	-5 dB	6,3 dB
384 kbps	-12,8 dB	-0,8 dB	6,2 dB

6.2.4 Uplink DCH demodulation requirements

6.2.4.1 Summary of test measurement services

The reference measurement channel for the 4 test services is given hereafter [27]:

Table 6.24: Reference measurement channels - Uplink

Parameter		DCH for DTCH/DCCH						Unit
DPDCH	Information bit rate	1,2/0	4,75/0,75	12,2/2,4	64/2,4	144/2,4	384/2,4	Kbps
	Physical channel	15/-	30/15	60/15	240/15	480/15	960/15	Kbps
	Spreading factor	256	128	64	16	8	4	-
	Repetition rate	233/-	45/50	22/22	19/19	8/8	-18/-17	%
	Interleaving		20/40	20/40	40/40	40/40	40/40	ms
	Number of DPDCHs	1	1	1	1	1	1	-
DPCCH	Dedicated pilot	6						Bit/slot
	Power control	2						Bit/slot
	TFCI	2						Bit/slot
	Spreading factor	256						
Power ratio of DPCCH/DPDCH		-2,69	-2,69	-2,69	-5,46	-9,54	-9,54	dB
Closed loop power control		Off						

6.2.4.2 Margins

Performance requirement include margin in order to take into account effects that are not modelled in simulations (imperfect channel estimation and path search, over sampling, number of floating points and all gateway hardware margins).

Margins are much lower than for terrestrial Node B equipment due to the fact that satellite gateway modems are less cost constrained.

Table 6.25: Margin applied to uplink DCH performance

Channel	Margin
AWGN	1 dB
All other channels	1,5 dB

6.2.4.3 Demodulation in static conditions

Unlike terrestrial test conditions for UL 3GPP performance requirements, Rx antenna diversity is not considered for satellite complexity reasons. This together with a different gateway implementation margin is the reason why performance requirement differs from 3GPP for static environment.

Table 6.26: DCH requirements in static propagation conditions - Uplink

Data rate	$\frac{E_b}{N_0}$
1,2 kbps	7,4 dB
4,75 kbps	7 dB
12,2 kbps	6,8 dB
64 kbps	3,5 dB
144 kbps	2,9 dB
384 kbps	3 dB

6.2.4.4 Demodulation in ITU channel model A conditions

Table 6.27: DCH requirements in ITU channel model A conditions - Uplink

Data rate	Speed	$\frac{E_b}{N_0}$		Data rate	Speed	$\frac{E_b}{N_0}$	
		LOS	NLOS			LOS	NLOS
1,2 kbps	3 km/h	9,1 dB	18 dB	64 kbps	3 km/h	4,5 dB	16,3 dB
	50 km/h	9,1 dB	10,4 dB		50 km/h	4,5 dB	7,9 dB
	120 km/h	9,2 dB	10,2 dB		120 km/h	4,5 dB	6,5 dB
	250 km/h	9,8 dB	11,9 dB		250 km/h	4,6 dB	7,8 dB
4,75 kbps	3 km/h	8,2 dB	20,6 dB	144 kbps	3 km/h	3,9 dB	15,7 dB
	50 km/h	8,3 dB	12,4 dB		50 km/h	3,9 dB	7,4 dB
	120 km/h	8,2 dB	10,7 dB		120 km/h	3,8 dB	6,1 dB
	250 km/h	8,6 dB	11,2 dB		250 km/h	4 dB	8,6 dB
12,2 kbps	3 km/h	7,8 dB	20,3 dB	384 kbps	3 km/h	4,1 dB	18,8 dB
	50 km/h	7,8 dB	12,2 dB		50 km/h	3,9 dB	11,8 dB
	120 km/h	7,8 dB	10,2 dB		120 km/h	3,9 dB	9,8 dB
	250 km/h	8 dB	10,9 dB		250 km/h	3,9 dB	10,8 dB

6.2.4.5 Demodulation in ITU channel model B conditions

Table 6.28: DCH requirements in ITU channel model B conditions - Uplink

Data rate	Speed	$\frac{E_b}{N_0}$		Data rate	Speed	$\frac{E_b}{N_0}$	
		LOS	NLOS			LOS	NLOS
1,2 kbps	3 km/h	9,2 dB	17,2 dB	64 kbps	3 km/h	4,8 dB	15,2 dB
	50 km/h	9,2 dB	10,4 dB		50 km/h	4,8 dB	7,8 dB
	120 km/h	9,4 dB	10,1 dB		120 km/h	4,7 dB	6,4 dB
	250 km/h	10 dB	11,8 dB		250 km/h	4,9 dB	7,6 dB
4,75 kbps	3 km/h	8,5 dB	19,5 dB	144 kbps	3 km/h	4,2 dB	14,6 dB
	50 km/h	8,5 dB	12,3 dB		50 km/h	4,2 dB	7,2 dB
	120 km/h	8,5 dB	10,5 dB		120 km/h	4,1 dB	6 dB
	250 km/h	8,8 dB	11,1 dB		250 km/h	4,3 dB	8,5 dB
12,2 kbps	3 km/h	8,1 dB	19,2 dB	384 kbps	3 km/h	4,7 dB	17,4 dB
	50 km/h	8,1 dB	12 dB		50 km/h	4,3 dB	11,3 dB
	120 km/h	8,1 dB	10,1 dB		120 km/h	4,2 dB	9,3 dB
	250 km/h	8,3 dB	10,8 dB		250 km/h	4,2 dB	10,2 dB

6.2.4.6 Demodulation in ITU channel model C conditions

Table 6.29: DCH requirements in ITU channel model C conditions - Uplink

Data rate	Speed	$\frac{E_b}{N_0}$		Data rate	Speed	$\frac{E_b}{N_0}$	
		LOS	NLOS			LOS	NLOS
1,2 kbps	3 km/h	9,8 dB	15,1 dB	64 kbps	3 km/h	5,7 dB	13,3 dB
	50 km/h	10 dB	10 dB		50 km/h	5,6 dB	6,9 dB
	120 km/h	10 dB	9,9 dB		120 km/h	5,6 dB	6 dB
	250 km/h	10,6 dB	11,7 dB		250 km/h	5,6 dB	7 dB
4,75 kbps	3 km/h	9,3 dB	17 dB	144 kbps	3 km/h	5 dB	12,6 dB
	50 km/h	9,3 dB	11,1 dB		50 km/h	5,2 dB	6,4 dB
	120 km/h	9,3 dB	9,9 dB		120 km/h	5,1 dB	5,5 dB
	250 km/h	9,5 dB	10,9 dB		250 km/h	5,1 dB	7,4 dB
12,2 kbps	3 km/h	8,9 dB	16,8 dB	384 kbps	3 km/h	6,2 dB	14,5 dB
	50 km/h	9 dB	10,6 dB		50 km/h	5,6 dB	9,6 dB
	120 km/h	9 dB	9,4 dB		120 km/h	5,3 dB	8 dB
	250 km/h	9,1 dB	10,2 dB		250 km/h	5,2 dB	8,5 dB

6.2.4.7 Demodulation in IMR environment conditions (no satellite signal reception)

In case IMRs are equipped with Rx antenna diversity, performance requirements from TS 125 141 [27] apply.

6.2.4.8 Demodulation in combined satellite and IMR environment conditions

In case IMRs are equipped with Rx antenna diversity, signal path from satellite becomes negligible and performance requirements from TS 125 141 [27] apply.

Otherwise, performance requirements specified hereafter apply.

Table 6.30: DCH requirements in combined satellite and IMR conditions; Uplink

Data rate	Speed	$\frac{E_b}{N_0}$		Data rate	Speed	$\frac{E_b}{N_0}$	
		LOS	NLOS			LOS	NLOS
1,2 kbps	3 km/h	14 dB	14,4 dB	64 kbps	3 km/h	8,8 dB	9,4 dB
	50 km/h	12,5 dB	12,8 dB		50 km/h	6,5 dB	6,8 dB
	120 km/h	12,8 dB	13,2 dB		120 km/h	6,5 dB	6,9 dB
	250 km/h	14,7 dB	15 dB		250 km/h	8 dB	8,3 dB
4,75 kbps	3 km/h	12,8 dB	13,5 dB	144 kbps	3 km/h	8,3 dB	9 dB
	50 km/h	10,9 dB	11,4 dB		50 km/h	6,1 dB	6,4 dB
	120 km/h	11,1 dB	11,4 dB		120 km/h	6,1 dB	6,6 dB
	250 km/h	12,6 dB	12,9 dB		250 km/h	8,2 dB	8,5 dB
12,2 kbps	3 km/h	11,9 dB	12,4 dB	384 kbps	3 km/h	8,7 dB	9,5 dB
	50 km/h	9,9 dB	10,3 dB		50 km/h	7 dB	7,6 dB
	120 km/h	9,9 dB	10,3 dB		120 km/h	6,7 dB	7,2 dB
	250 km/h	11,3 dB	11,7 dB		250 km/h	7,9 dB	8,3 dB

Performance requirements for the candidate test cases from Satin are presented hereafter (applicable to low power IMRs).

Table 6.31: DCH requirements in combined satellite and low power IMR conditions; Satin test cases; Uplink

Data rate	S-Case 1 $\frac{E_b}{N_0}$	S-Case 2 $\frac{E_b}{N_0}$	S-Case 3 $\frac{E_b}{N_0}$	Data rate	S-Case 4 $\frac{E_b}{N_0}$	S-Case 5 $\frac{E_b}{N_0}$	S-Case 6 $\frac{E_b}{N_0}$
1,2 kbps	16,1 dB	13,6 dB	11 dB	1,2 kbps	10,7 dB	9,9 dB	13,3 dB
4,75 kbps	18,4 dB	14,3 dB	10 dB	4,75 kbps	11,2 dB	10,3 dB	11,7 dB
12,2 kbps	17,8 dB	13,8 dB	9,2 dB	12,2 kbps	10,2 dB	9,3 dB	10,7 dB
64 kbps	14,3 dB	10,7 dB	5,8 dB	64 kbps	6,9 dB	5,6 dB	7,2 dB
144 kbps	13,5 dB	10,2 dB	5,3 dB	144 kbps	7 dB	5,2 dB	7,2 dB
384 kbps	15,9 dB	10,9 dB	6,7 dB	384 kbps	6,7 dB	6,7 dB	7,6 dB

6.2.4.9 Demodulation in aeronautical environment

Table 6.32: DCH requirements in aeronautical environment - Uplink

Data rate	$\frac{E_b}{N_0}$
1,2 kbps	11,6 dB
4,75 kbps	8,5 dB
12,2 kbps	7,9 dB
64 kbps	4,4 dB
144 kbps	3,9 dB
384 kbps	3,7 dB

6.2.5 Demodulation requirements synthesis

6.2.5.1 Propagation Link Margin

6.2.5.1.1 Satellite signal LOS view

In case UE is in ITU satellite models with LOS view of the satellite signal, simulation results show required propagation link margin is homogeneous all the test services.

Table 6.33: Maximum Propagation Link Margin; LOS ITU models

Service type	Downlink	Uplink
ITU Model A (rural)	2,1 dB	1,2 dB
ITU Model B (sub-urban)	3 dB	1,8 dB
ITU Model C (urban)	5,3 dB	3,3 dB

6.2.5.1.2 Satellite signal NLOS view

When UEs are not in LOS view of the satellite signal, the required link margin becomes more critical, particularly for UEs at low speed (3 km/h), and is test service data rate dependent. Link margins are defined for two types of system deployment: satellite only (NLOS) and combined satellite/IMRs.

Table 6.34: Maximum Propagation Link Margin; NLOS ITU models and combined Satellite IMR

Service type	Downlink		Uplink	
	Link margin Sat. only	Link margin Sat. + IMR	Link margin Sat. only	Link margin Sat. + IMR
Speech 1,2 kbps	8,6 dB	3,9 dB	10,5 dB	7,6 dB
Speech 4,75 kbps	13,5 dB	4,6 dB	13,5 dB	6,4 dB
Speech 12,2 kbps	16,5 dB	4,5 dB	13 dB	5,6 dB
Data 64 kbps	14,5 dB	5,3 dB	12,3 dB	5,8 dB
Data 144 kbps	19,2 dB	5,7 dB	12,3 dB	6,1 dB
Data 384 kbps	16,5 dB	6,5 dB	15,4 dB	6,6 dB

As shown in Table 6.34, IMR deployment allows to reduce link margin, particularly for the downlink direction. This advantage is to be added to the fact IMRs deployment solves the problem of path blockage inherent to satellite systems without satellite diversity.

Note that these link margins are defined with the assumption that IMRs do not implement antenna diversity. If IMRs antenna diversity is implemented, the required link margin is substantially reduced.

Note also that introducing this propagation link margin for NLOS satellite view drives to the situation that the system is designed for accepting short range indoor penetration, as specified by ITU recommendation for Indoor Satellite Environment (10 dB to 15 dB margin [1]).

6.2.5.2 Increasing interleaving depth

Required E_b/N_t , and thus average $\frac{DPCH - E_c}{I_{or}}$ power ratio, can be decreased by increasing interleaving depth.

One drawback of increasing interleaving depth is that this requires increasing UE memory size for buffering frames. This could be sensible for high data rate services (384 kbps).

Simulations have been run with interleaving depth of 4 and 8 for all the test environments. The simulation results show a decrease of the required propagation link margin, and an homogenization whatever the service type.

6.2.5.2.1 Downlink

The maximum required link margin and the reduction of the required link margin to be compared to the test cases are depicted in table 6.35.

Table 6.35: Link margin gain with interleaving depth 4 and 8; Downlink

Service type	TTI = 40ms		TTI = 80 ms	
	Link margin	Margin gain	Link margin	Margin gain
Data 64 kbps	11,9 dB	2,3 dB	10 dB	4,2 dB
Data 144 kbps	12 dB	7,4 dB	10 dB	9,4 dB
Data 384 kbps	12,2 dB	3,8 dB	10,4 dB	2,1 dB

6.2.5.2.2 Uplink

The maximum required link margin and the reduction of the required link margin to be compared to the test cases are depicted in table 6.36.

Table 6.36: Link margin gain with interleaving depth 8; Uplink

Service type	TTI = 80 ms	
	Link margin	Margin gain
Data 64 kbps	8 dB	4,3 dB
Data 144 kbps	7,7 dB	4,6 dB
Data 384 kbps	12,3 dB	3,1 dB

6.2.5.3 Spatial diversity

Reception quality can be improved with two kinds of spatial diversity: UE antenna diversity and satellite diversity.

NOTE: Satellite antenna diversity is not considered for satellite implementation complexity reasons.

6.2.5.3.1 UE antenna diversity

UE may be equipped with two antennas.

Simulation results show a reduction of the required link margin regarding the propagation channel as depicted in table 6.37.

Table 6.37: Link margin reduction; UE antenna diversity

Propagation channel	Link margin reduction (dB)	
	Downlink	Uplink
AWGN	3	2,8
Case 1, S-Case 1	7	6,4
Case 2, S-Case 2	5,8	5
Case 3, S-Case 3	3,5	2,9
Case 4	7	6
Case 5, S-Case 5	4	4,5
Case 6, S-Case 6	4	4,5
S-Case 4	4,4	2,4
ITU A, B, C (LOS)	3 (ITU A, B) up to 4 (ITU C)	3
ITU A, B, C (NLOS)	3 (50, 120, 250 km/h) up to 8 (3 km/h)	3,5 (50, 120, 250 km/h) up to 7,2 (3 km/h)
High and Low Power IMR	3,6	2,8

6.2.5.3.2 Satellite diversity

Satellite diversity can be provided when the system is built with several satellites. Advantages are:

- reduce IMRs deployment;
- solve path blockage problem inherent to satellite systems;
- reduce required link margin for situations where satellite signal is strongly attenuated (but not completely obstructed);
- ease UE handover when moving through coverage areas.

The method is also applicable to spots belonging to a given satellite (spot diversity) and satellite + IMRs.

In the following, it is assumed that the number of satellites offering diversity is limited to 2.

When switched to satellite diversity mode, UE is simultaneously radio connected to both satellites over the same carrier frequency.

UE transmits an unique signal (one unique scrambling code). This uplink signal is received by both satellites, redirected to the gateway and combined at Node B rake receiver.

In the downlink direction, each satellite transmits with a distinct scrambling code, UE rake receivers combine both signals.

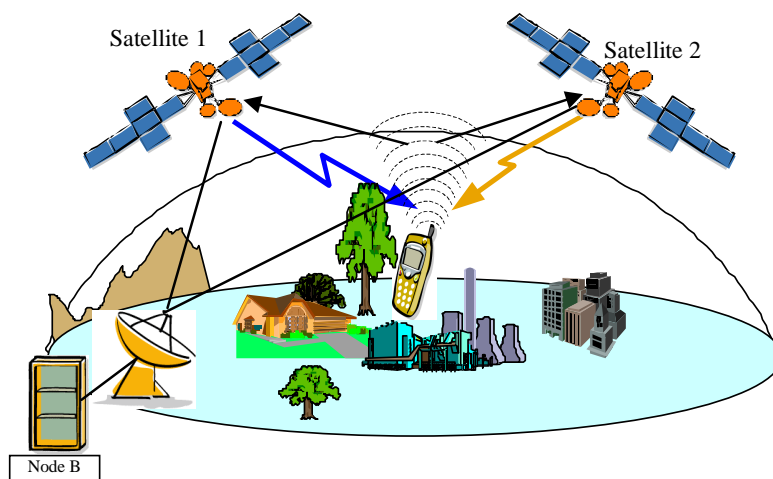

Figure 6.1: Satellite diversity

Simulations were driven for several UE situations in view of both satellites:

- 1 satellite LOS, the other satellite NLOS: LOS component is such predominant that performances are equivalent to 1 single satellite with LOS. SSDT mechanism allows to switch off 2nd satellite in order not to waste scarce satellite transmit power.
- Both satellites LOS.
- None of the satellites LOS.

Simulation results presented hereafter highlight Tx E_b/N_0 gain due to satellite diversity, i.e. the difference versus the path loss difference of Tx E_b/N_0 obtained with and without satellite diversity for reaching a target BLER of 1 %. Results are given as a function of the 2nd satellite path loss difference, i.e. path loss between UE and 1st satellite is taken as a reference.

6.2.5.3.2.1 Both satellites LOS

Path loss difference is to be understood as distinct satellite Rx antenna gain (uplink)/Tx satellite power capability (downlink).

Diversity gain is practically identical for UE speed from 0 km/h to 50 km/h. It is limited to a maximum of ~1 dB (12,2 kbps).

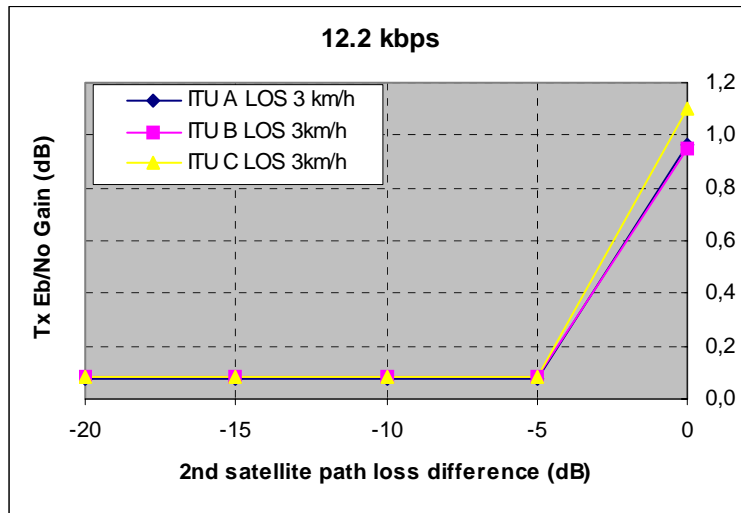

Figure 6.2: Satellite diversity gain; LOS; Uplink; 12,2 kbps

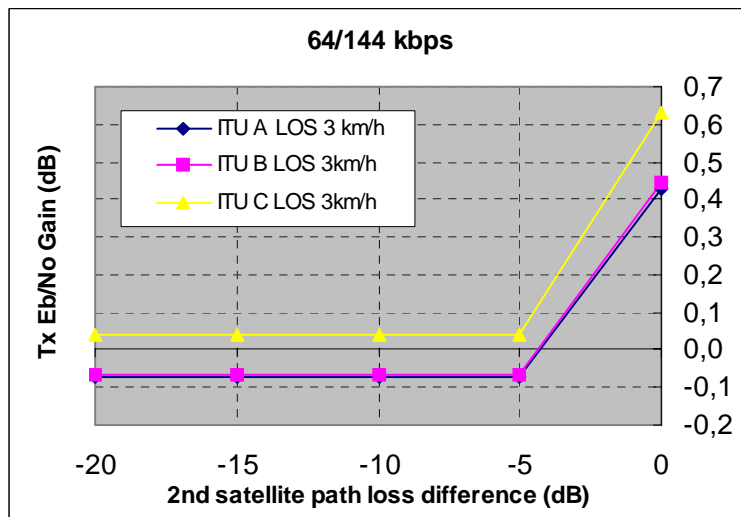

Figure 6.3: Satellite diversity gain; LOS; Uplink; 64/144 kbps

In the downlink direction, Tx Eb/No gain is negative and almost identical whatever service data rate. Tx power gain is counteracted by increase of interference, due to non orthogonality of both satellites scrambling codes. Nevertheless, satellite diversity can still be envisaged for allowing dynamic power distribution among satellites in high traffic load conditions.

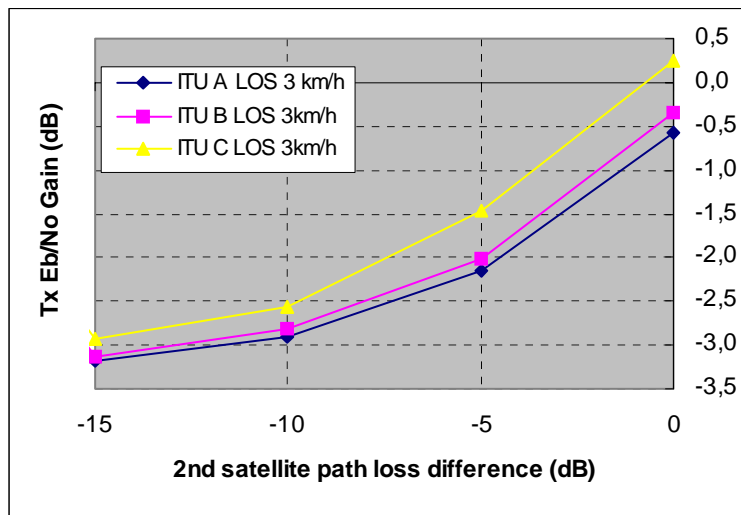

Figure 6.4: Satellite diversity gain; LOS; Downlink

6.2.5.3.2.2

None of the satellite LOS

Satellite diversity gain is significant when UE is suffering NLOS with none of the satellites. Furthermore, the case when 2nd satellite path loss difference is 0 dB looks an highly probable assumption. Maximum Tx Eb/No gain is reached for low speed UEs. In the downlink direction, it is almost independent of the service data rate.

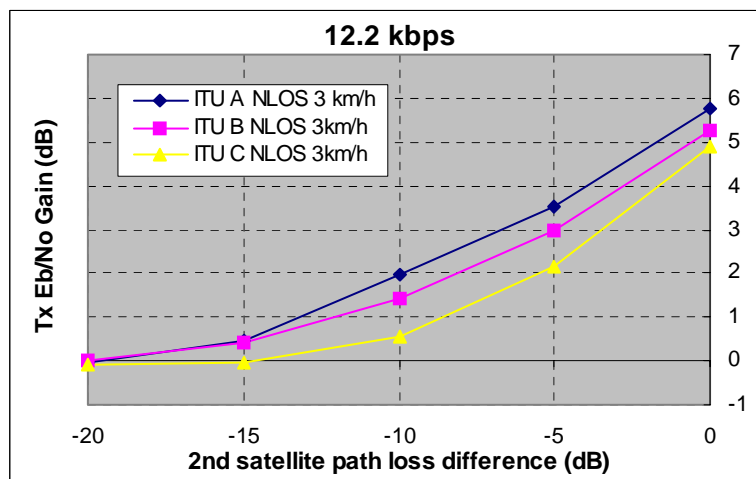

Figure 6.5: Satellite diversity gain; NLOS; Uplink; 12,2 kbps; 3 km/h

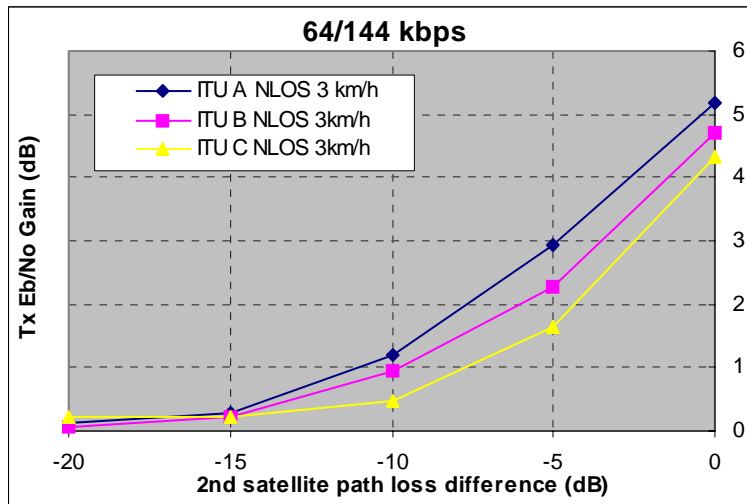

Figure 6.6: Satellite diversity gain; NLOS; Uplink; 64/144 kbps; 3 km/h

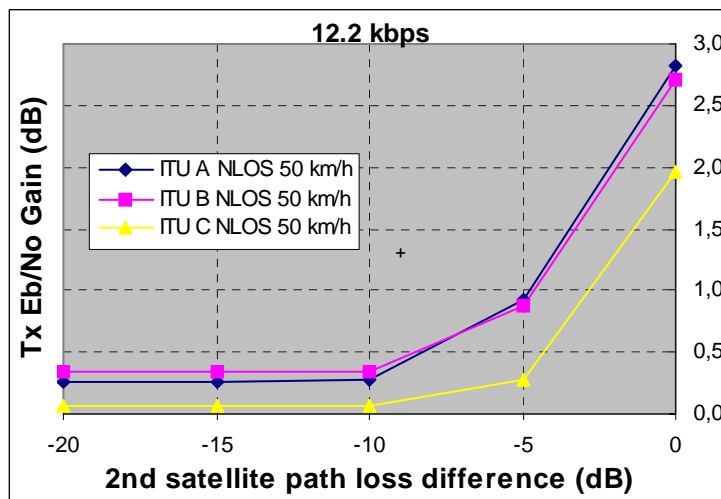

Figure 6.7: Satellite diversity gain; NLOS; Uplink; 12,2 kbps; 50 km/h

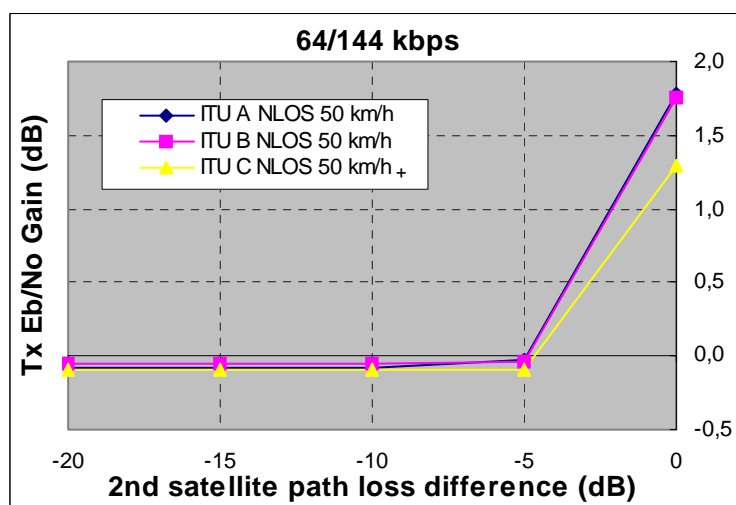

Figure 6.8: Satellite diversity gain; NLOS; Uplink; 64/144 kbps; 50 km/h

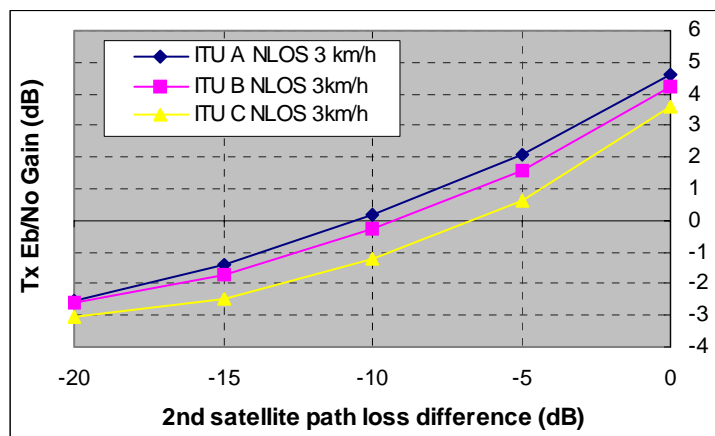

Figure 6.9: Satellite diversity gain; NLOS; Downlink; 3 km/h

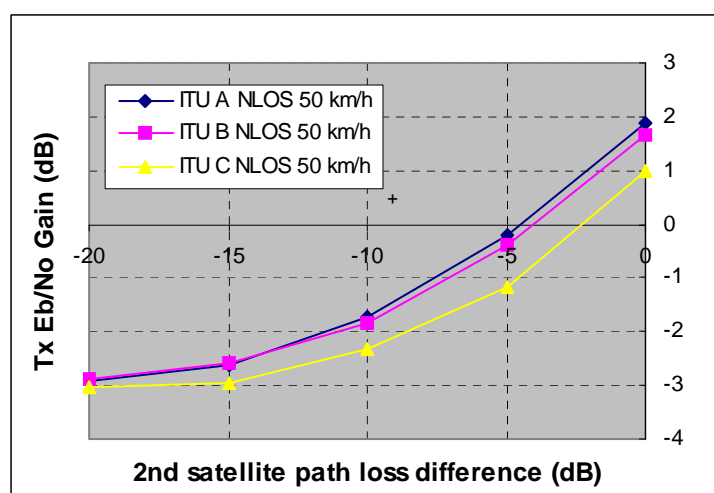

Figure 6.10: Satellite diversity gain; NLOS; Downlink; 50 km/h

6.2.5.4 Slow Power Control performance

Slow Power Control performance has been evaluated for radio links suffering from slow sinusoidal fading (2 Hz, 10 dB peak to peak attenuation) as well as brutal signal obstruction (10 dB signal attenuation), this channel attenuation being superimposed to either AWGN or ITU A fading.

The required Rx Eb/No for reaching a BLER of 1 % is presented below, both in absence and presence of slow power control.

Also are given impulse responses for a reaching a BLER of 1 %, of:

- the received Eb/No for several data rates: 12,2 kbps, 64 kbps and 144 kbps;
- the channel variation;
- the Tx power relative to initial power (i.e. without fading).

6.2.5.4.1 Uplink Slow Power Control

The required Rx Eb/No for reaching a BLER of 1 %, both in absence and presence of slow power control, is:

Table 6.38: Slow Power Control Rx Eb/No - Uplink

Data rate	AWGN+ Slow fading	ITU A + Slow fading	AWGN + Signal obstruction	ITU A + Signal obstruction
12,2 kbps				
No Power Ctrl	12,8 dB	13,7 dB	12,0 dB	13,6 dB
Slow Power Ctrl	8,4 dB	9,9 dB	8,6 dB	9,6 dB
64 kbps				
No Power Ctrl	9,8 dB	10,7 dB	10,5 dB	11,9 dB
Slow Power Ctrl	6,0 dB	8,4 dB	5,1 dB	4,9 dB
144 kbps				
No Power Ctrl	9,1 dB	10,1 dB	10,1 dB	11,5 dB
Slow Power Ctrl	5,2 dB	7,3 dB	5,3 dB	4,6 dB

Slow power control impulse response is as follows.

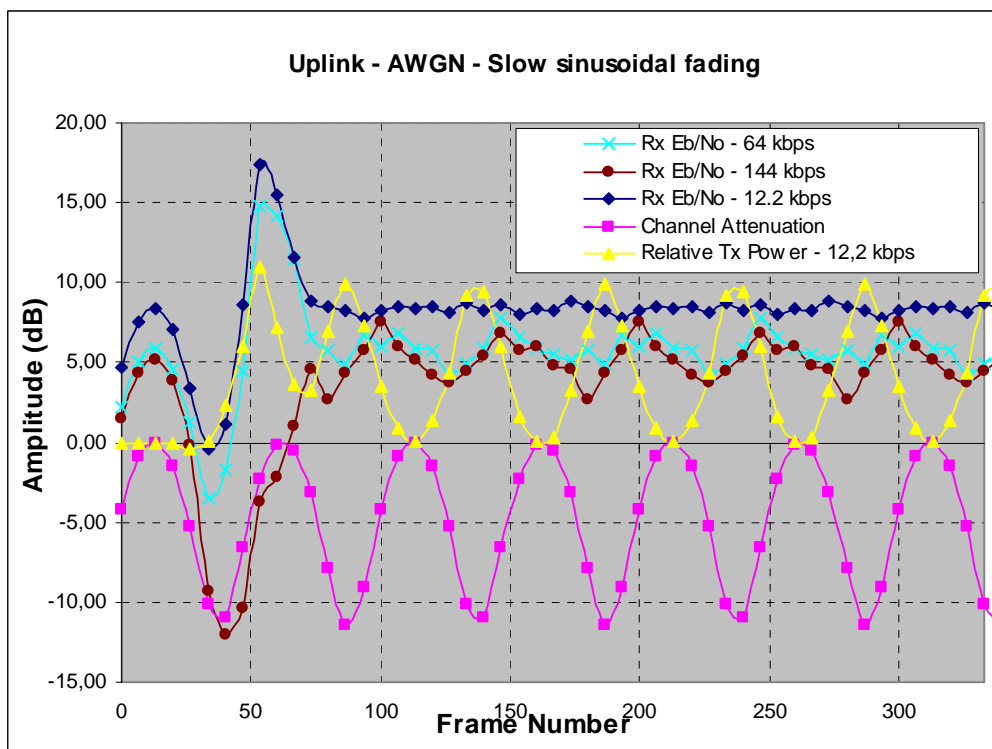

Figure 6.11: Slow Power Control Response to sinusoidal fading; AWGN; Uplink

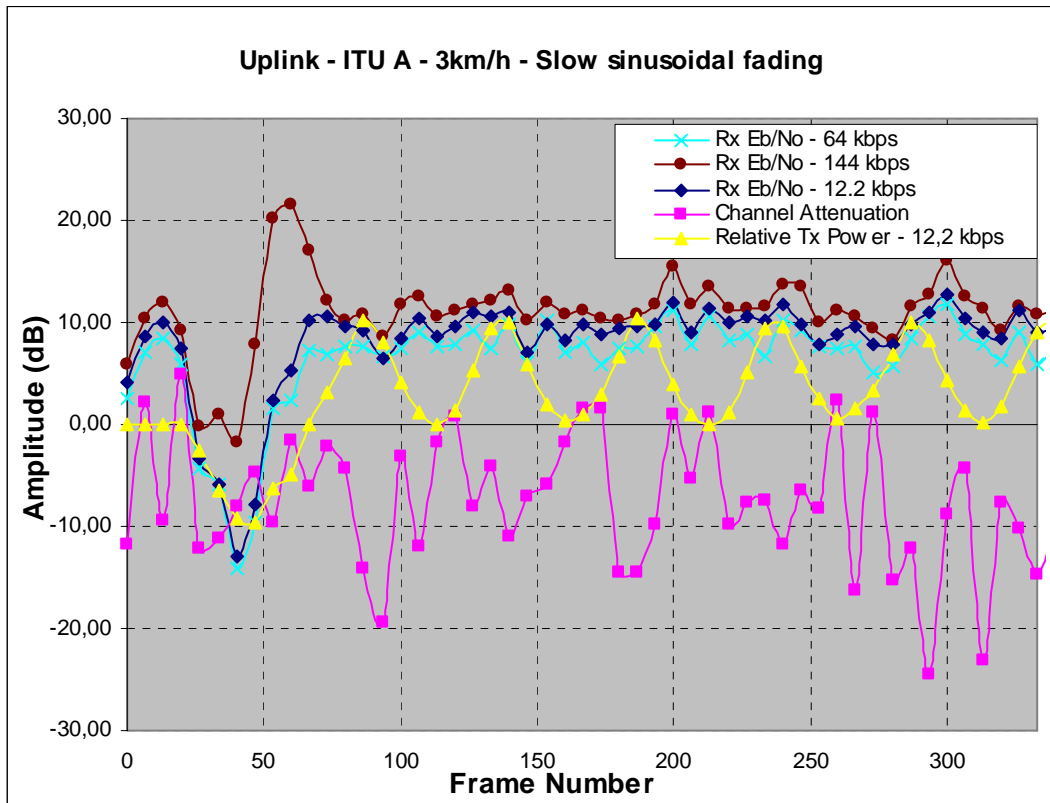

Figure 6.12: Slow Power Control Response to sinusoidal fading; ITU Model A; Uplink

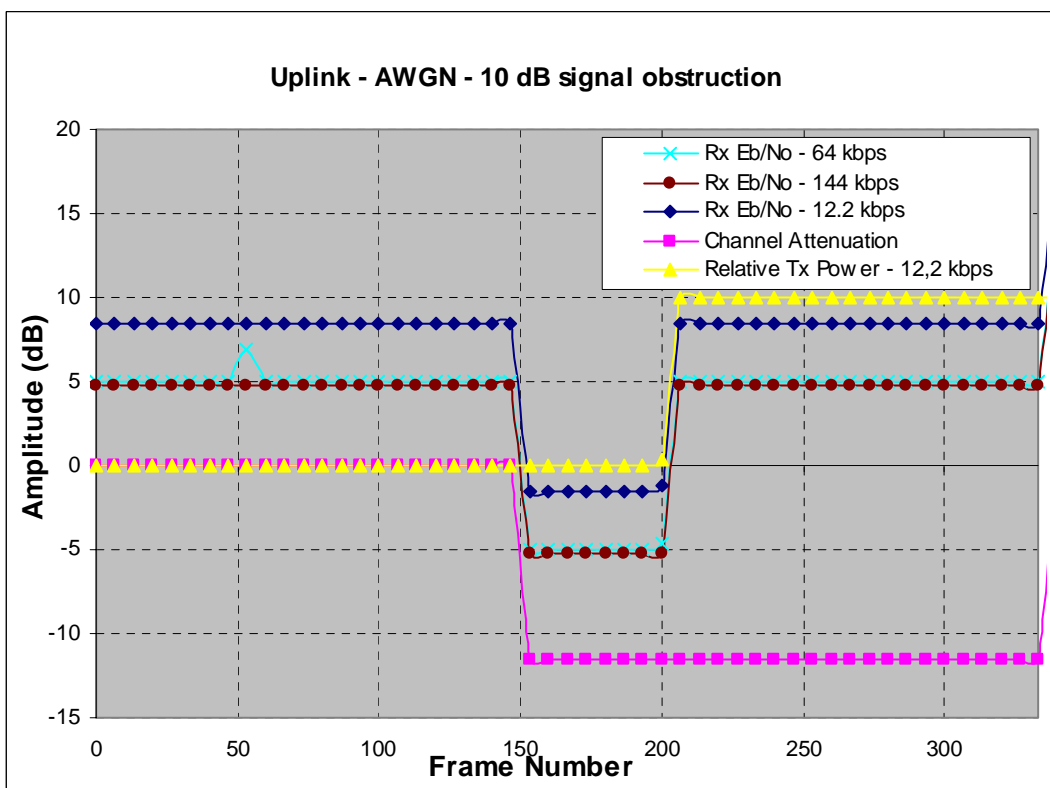

Figure 6.13: Slow Power Control Response to 10 dB Signal obstruction; AWGN; Uplink

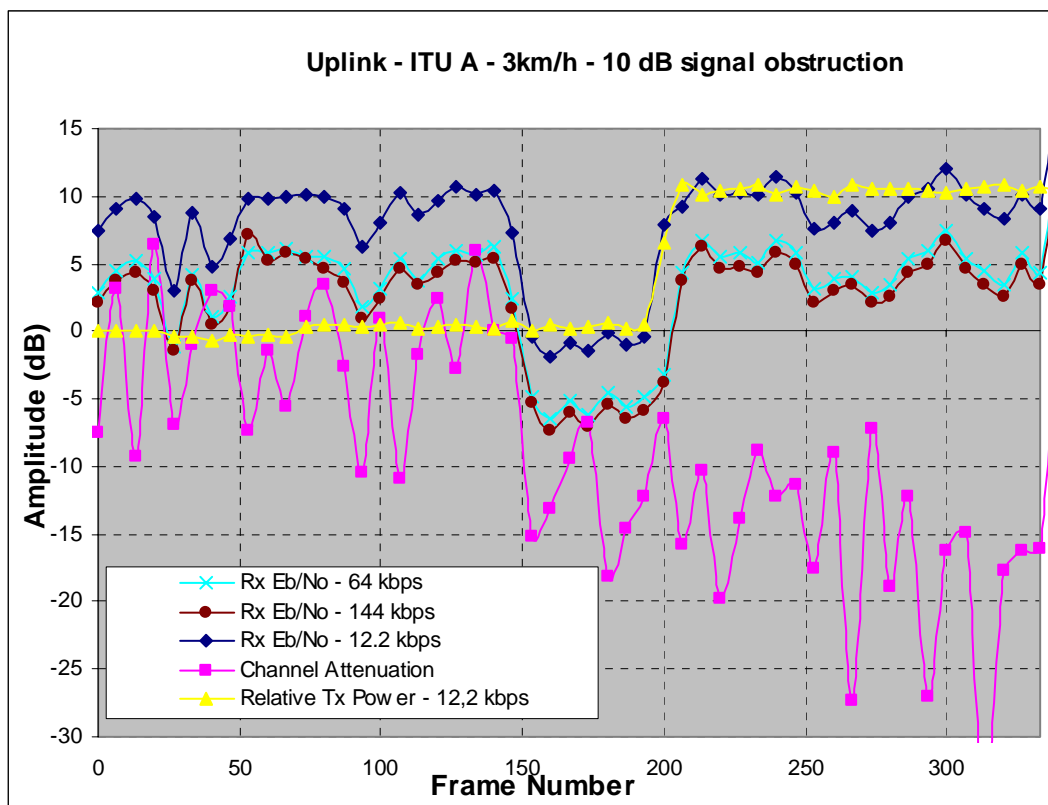

Figure 6.14: Slow Power Control Response to 10 dB Signal obstruction; ITU Model A; Uplink

6.2.5.4.2 Downlink Slow Power Control

The required Rx Eb/No for reaching a BLER of 1 %, both in absence and presence of slow power control, is:

Table 6.39: Slow Power Control Rx Eb/No - Downlink

Data rate	AWGN+ Slow fading	ITU A + Slow fading	AWGN + Signal obstruction	ITU A + Signal obstruction
12,2 kbps				
No Power Ctrl	13,3	14,2	10,5	12,0
Slow Power Ctrl	8,6	9,9	8,8	9,9
64 kbps				
No Power Ctrl	2,0	2,5	7,5	9,0
Slow Power Ctrl	2,0	7,6	5,7	6,4
144 kbps				
No Power Ctrl	10,1	11,1	9,5	11,0
Slow Power Ctrl	6,3	7,0	5,9	6,8

Slow power control impulse response is as follows.

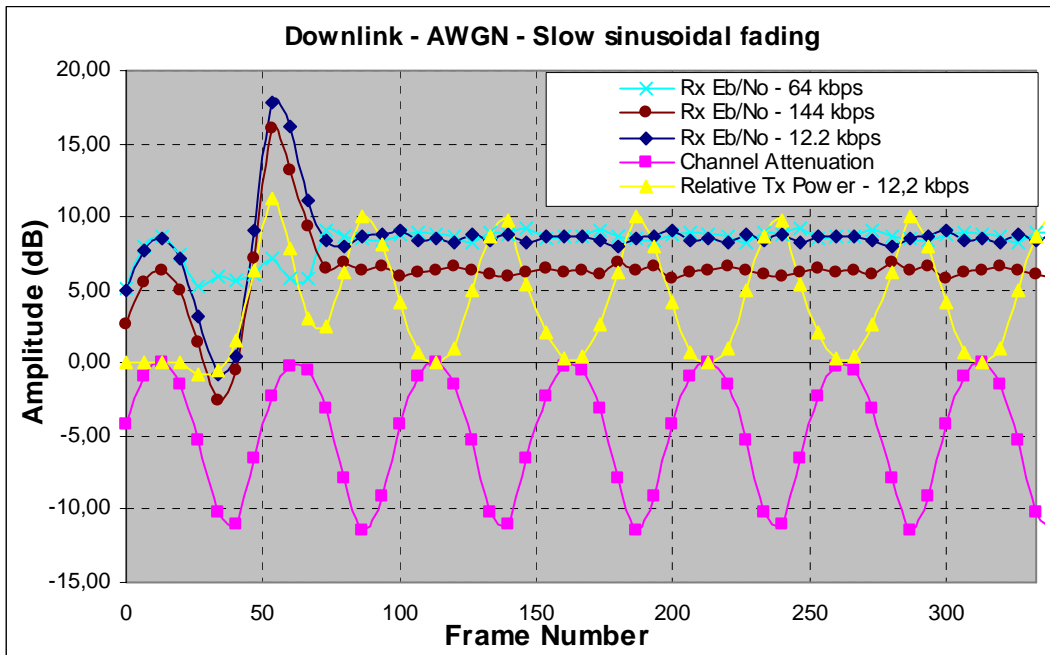

Figure 6.15: Slow Power Control Response to sinusoidal fading; AWGN; Downlink

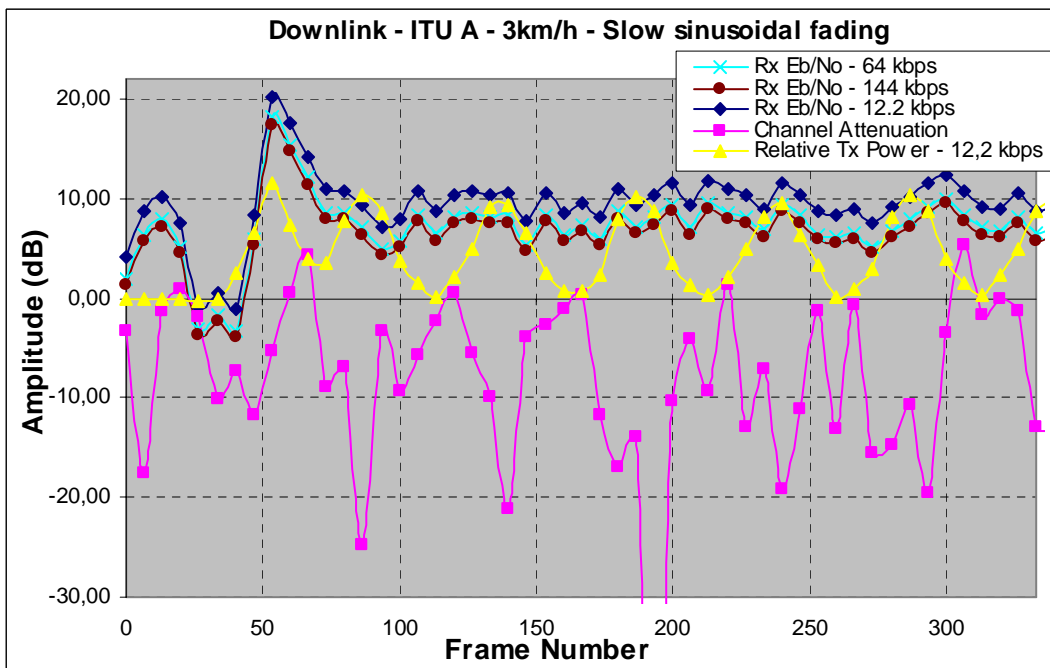

Figure 6.16: Slow Power Control Response to sinusoidal fading; ITU Model A; Downlink

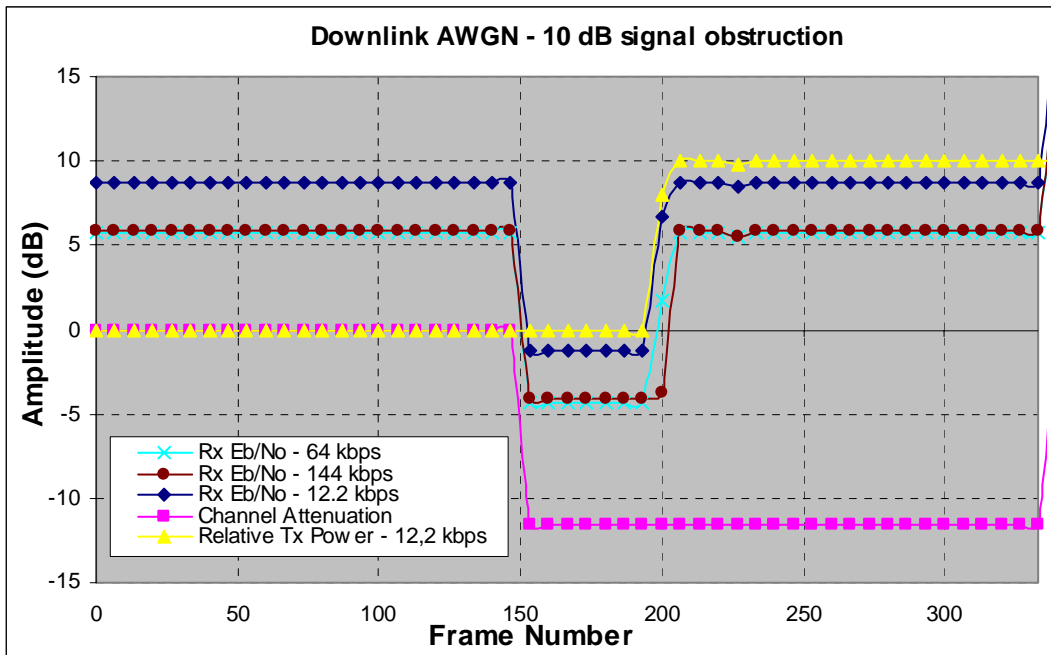

Figure 6.17: Slow Power Control Response to 10 dB Signal obstruction; AWGN; Downlink

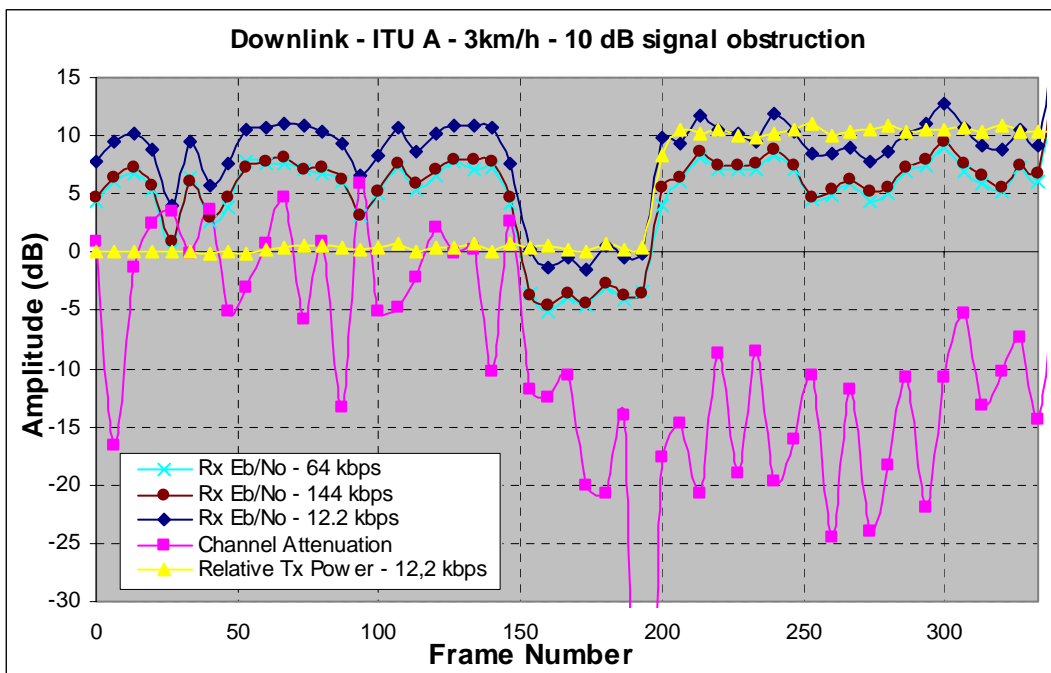

Figure 6.18: Slow Power Control Response to 10 dB Signal obstruction; ITU Model A; Downlink

6.2.5.5 Multi User Detection

Multi User Detection (MUD) can be envisaged for decreasing E_b/N_t .

In the uplink direction, MUD improvement is estimated to around 2,8 dB.

For the downlink direction, UE complexity impact and improvement are under evaluation.

6.2.6 Acquisition efficiency

Performance of initial spot synchronization was evaluated for several radio environments [37],[38]. They are resumed hereafter:

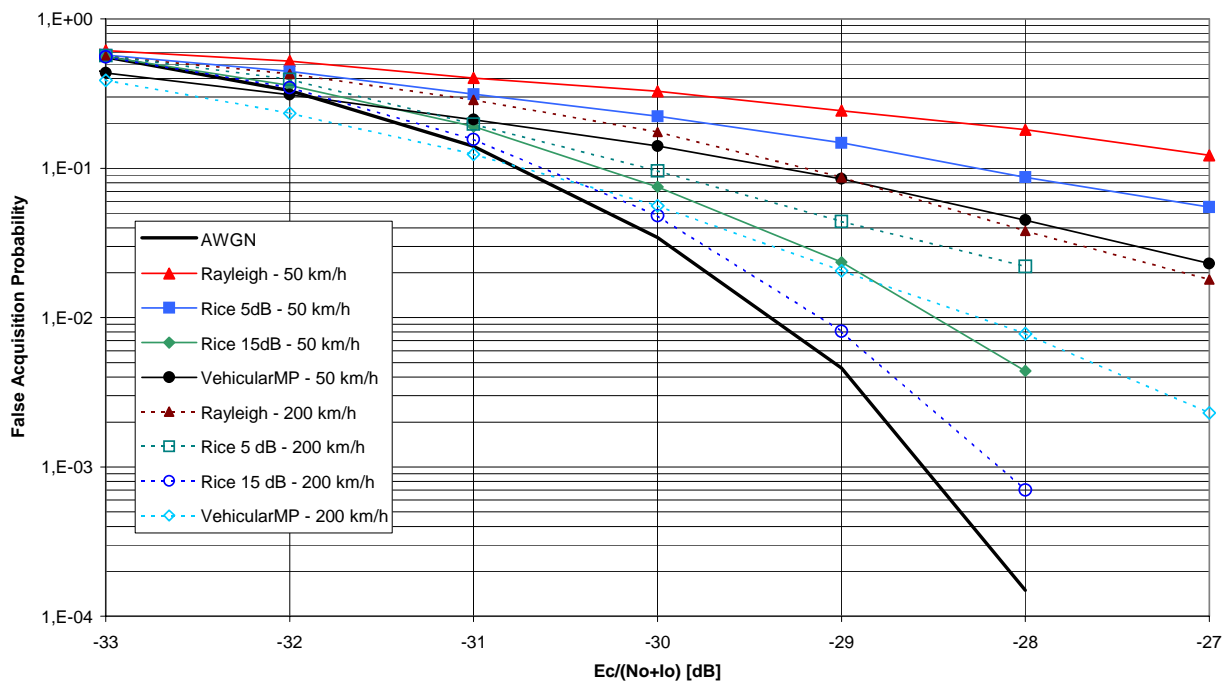

Figure 6.19: False Acquisition probability vs. E_c/N_o , step 1

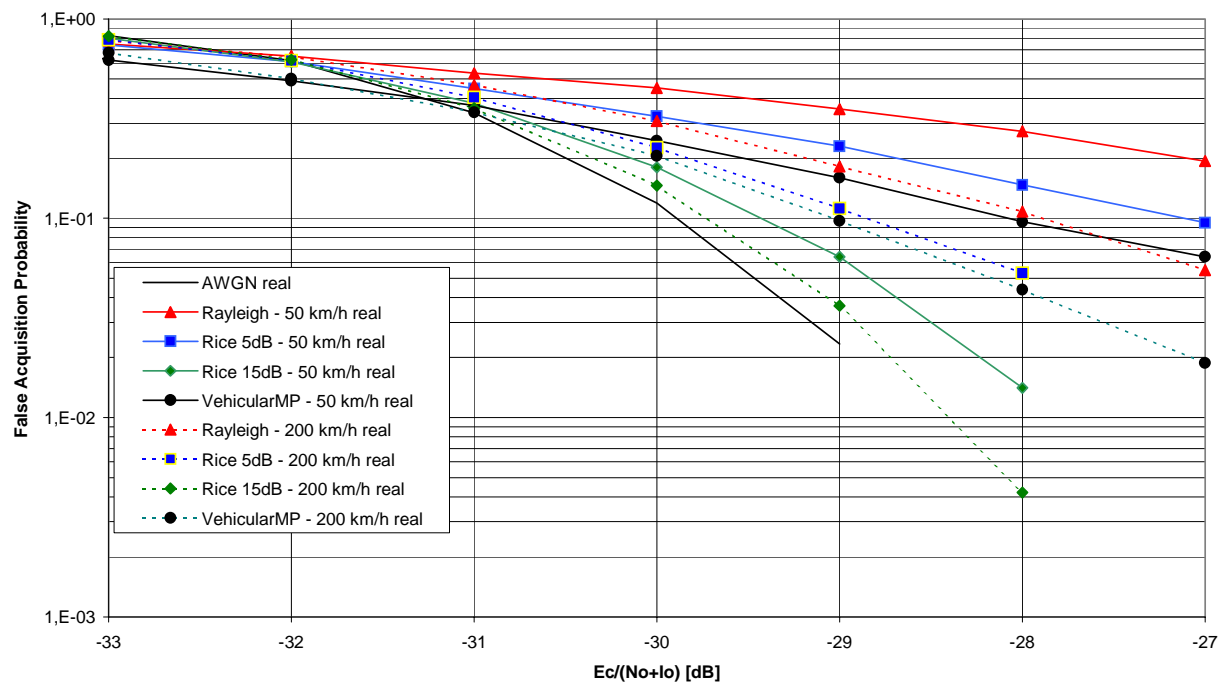

Figure 6.20: False Acquisition probability vs. E_c/N_o , step 2

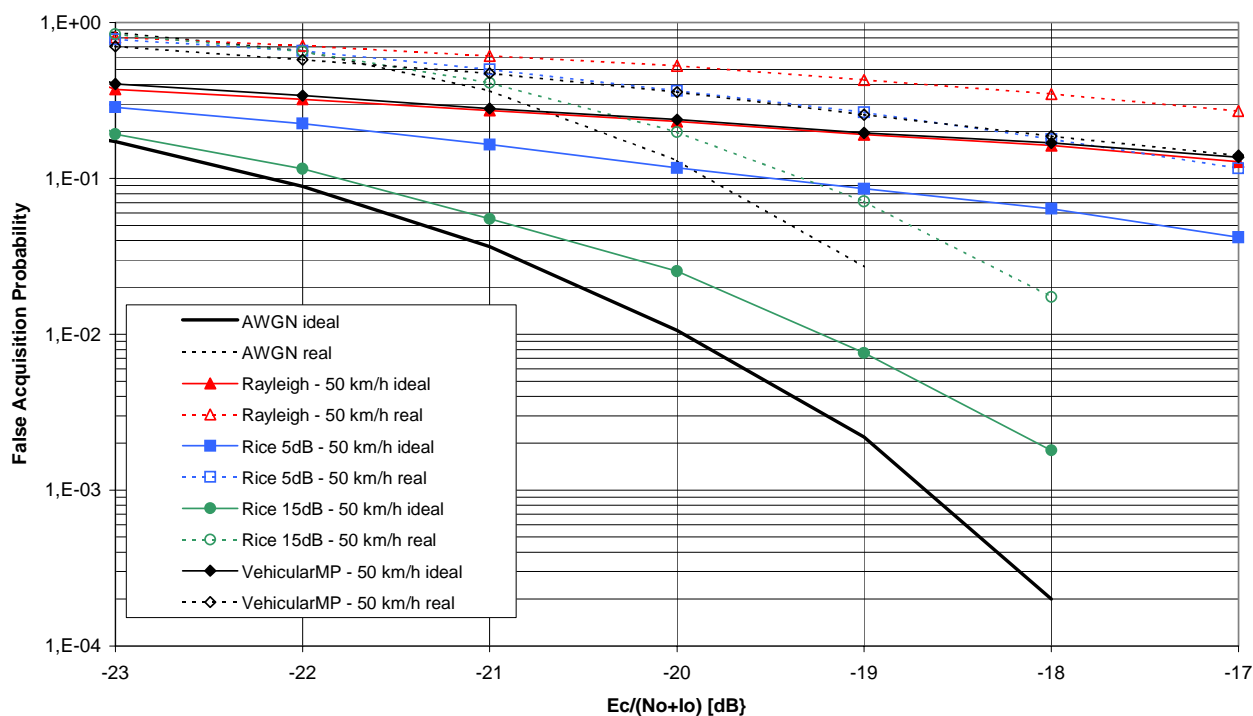

Figure 6.21: False Acquisition probability vs. E_c/N_o , step 3, 50 km/h

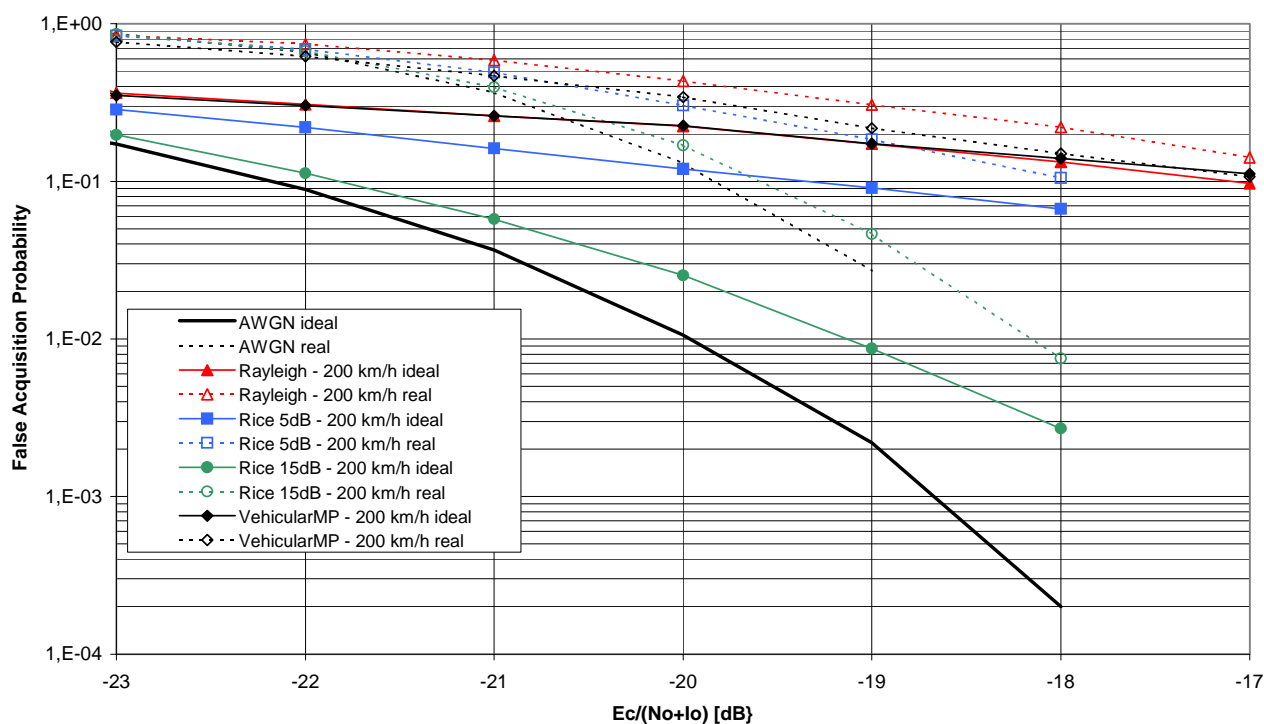

Figure 6.22: False Acquisition probability vs. E_c/N_o , step 3, 200 km/h

6.3 Satellite transmitter characteristics

Satellite transmission in the downlink MSS band is constrained by necessity to limit interference to terrestrial UMTS.

It is assumed that the main constraint will be due to the protection of the reception by IMT-2000 UEs, in the lower adjacent terrestrial channel.

For a 74 dBW satellite EIRP, the required attenuation level in the core band compared to co-channel operation can be derived as follows:

Table 6.40: Satellite transmitter characteristics

UE receiver	Max Antenna gain	0	dB
	Feeder loss	0	dB
	Tilt angle	0,0	°down
	Rx Noise Figure	9	dB
	Rx Noise level	-134,98	dBW/MHz
	Required I/N	-10	dB
	Maximum tolerable ACI	-144,98	dBW/MHz
Satellite	Satellite altitude	36 000	Km
	Frequency	2 170	MHz
	Path loss	191,6	dB
	Maximum tolerable satellite EIRP density	46,62	dBW/MHz
	Satellite EIRP	74	dBW
	Bandwidth	3,84	MHz
	Max in-band EIRP density	68,16	dBW/MHz
	Required attenuation	21,54	dB

The satellite spectrum mask and Adjacent Channel Leakage Ratio (ACLR) are as follows:

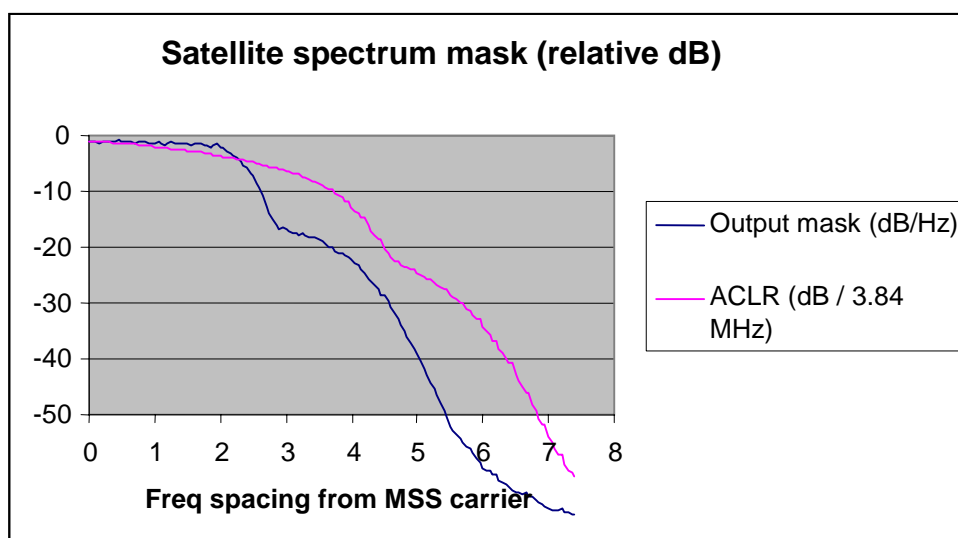

Figure 6.23: Satellite spectrum emission mask and ACLR

6.4 UE characteristics

Terrestrial 3GPP UE are to be upgraded, their radio implementation must be upgraded for frequency agility to MSS bands. The UE RF performances are:

Table 6.41: 3GPP Class 3 UE RF performance

Receive frequency (MHz)	2 170-2 200	
Transmit frequency (MHz)	1 980-2 010	
Receive/Transmit polarization	Linear	
Noise figure	9 dB	
Receiver noise floor	-99 dBm	
Antenna gain	0/2/4/14 dBi	
Maximum output power	24/27/33/39 dBm	
Transmission mask	Compliant with 3GPP UE requirements [10]	
ACLR (Adjacent Channel Leakage Ratio) as a function of carrier separation [10]	5 MHz	10 MHz
	33 dB	43 dB
ACS (Adjacent Channel Selectivity) as a function of carrier separation [10]	5 MHz	10 MHz
	33 dB	43 dB

6.5 IMR characteristics

Table 6.42: IMR power characteristics

Coverage area (°) IMR classes	Up to 360° (i.e. 120° per sector)		
	Wide area repeaters for macro-cell application	Medium range repeaters for micro-cell	Local area repeaters for pico-cell
Assumed height of IMRs (m)	30	6	6
Maximum output power (dBm)	43	30	24
Maximum Antenna gain (Tx) (dBi)	15	6	0
Transmission mask	Compliant with 3GPP Node B requirements [11]		
ACLR (Adjacent Channel Leakage ratio) as a function of carrier separation [11]	5 MHz	10 MHz	15 MHz
	45 dB	50 dB	67 dB

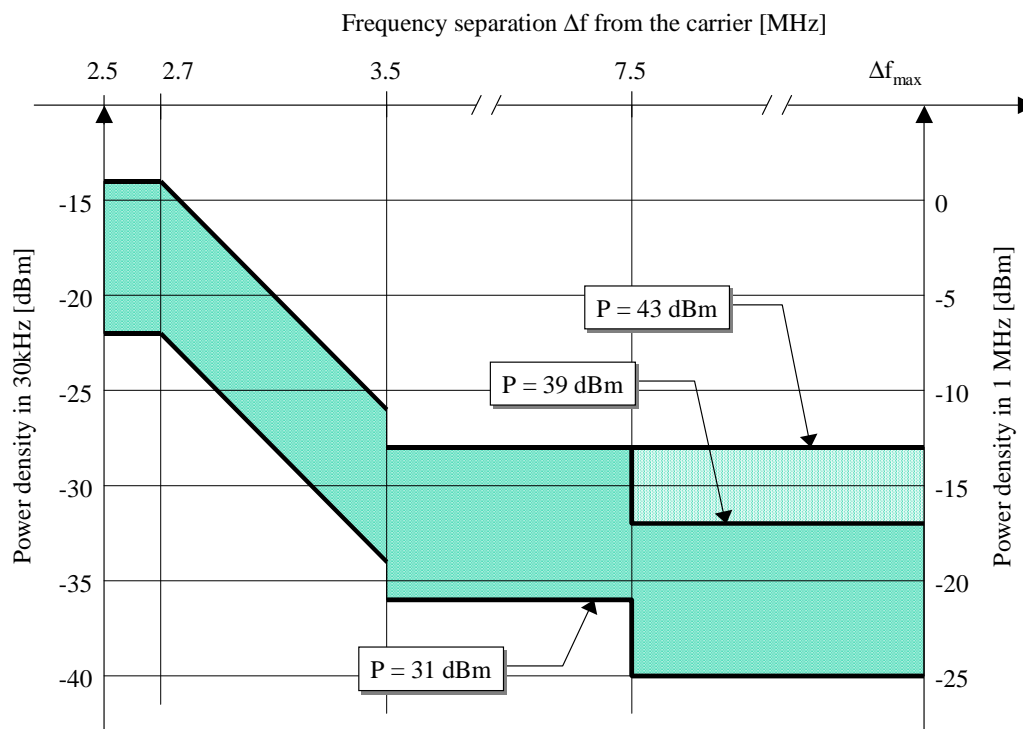

Illustrative diagram of spectrum emission mask

Figure 6.24: IMR transmission mask

7 System capacity

System capacity is firstly presented for static environment (AWGN channel), then for mobile environment and indoor penetration. Improvement thanks to IMRs deployment is also quantified for the downlink direction.

Detailed link budgets are given in annex C.

7.1 Downlink

On-board power consumption is indicated in order to highlight situations when spot capacity is not transmit power limited but interference limited.

7.1.1 Static environment

7.1.1.1 Data service 1,2 kbps

Table 7.1: System capacity; Speech 4,75 kbps; Downlink

Data rate (kbps)	Capacity/ carrier/ spot	Nb traffic codes/spot/ carrier	Nb 2 nd ary Scrambling codes/spot/ carrier	Spectrum efficiency as ITU	Power efficiency as ITU	On board Power consumption
1,2	(Mbps)			(bit/s/Hz)		(W)
Handset						
Max (40°)	0,865	721	1	0,18	12,18 %	199
Average (30°)	0,832	693	1	0,18	12,17 %	200
Min (16°)	0,798	665	1	0,17	12,17 %	198
Portable						
Max (40°)	0,881	734	1	0,19	12,18 %	200
Average (30°)	0,862	718	1	0,18	12,15 %	198
Min (16°)	0,842	702	1	0,18	12,18 %	198
Vehicular						
Max (40°)	0,882	735	1	0,19	12,16 %	200
Average (30°)	0,865	721	1	0,18	12,16 %	196
Min (16°)	0,847	706	1	0,18	12,17 %	197
Transportable						
Max (40°)	0,888	740	1	0,19	12,16 %	196
Average (30°)	0,878	732	1	0,19	12,19 %	195
Min (16°)	0,865	721	1	0,18	12,15 %	199

7.1.1.2 Speech service 4,75 kbps

Table 7.2: System capacity; Speech 4,75 kbps; Downlink

Data rate (kbps)	Capacity/ carrier/ spot	Nb traffic codes/spot/ carrier	Nb 2 nd ary Scrambling codes/spot/ carrier	Spectrum efficiency as ITU	Power efficiency as ITU	On board Power consumption
4,75	(Mbps)			(bit/s/Hz)		(W)
Handset						
Max (40°)	1,140	480	1	0,24	12,47 %	199
Average (30°)	1,071	451	1	0,23	12,49 %	198
Min (16°)	1,009	425	1	0,22	12,50 %	200
Portable						
Max (40°)	1,178	496	1	0,25	12,47 %	200
Average (30°)	1,145	482	1	0,24	12,49 %	200
Min (16°)	1,109	467	1	0,24	12,48 %	198
Vehicular						
Max (40°)	1,183	498	1	0,25	12,48 %	199
Average (30°)	1,150	484	1	0,25	12,40 %	200
Min (16°)	1,116	470	1	0,24	12,35 %	200
Transportable						
Max (40°)	1,199	505	1	0,26	12,50 %	199
Average (30°)	1,185	499	1	0,25	12,50 %	199
Min (16°)	1,169	492	1	0,25	12,51 %	199

7.1.1.3 Speech service 12,2 kbps

Table 7.3: System capacity; Speech 12,2 kbps; Downlink

Data rate (kbps)	Capacity/ carrier/ spot (Mbps)	Nb traffic codes/spot/ carrier	Nb 2 nd ary Scrambling codes	Spectrum efficiency as ITU (bit/s/Hz)	Power efficiency as ITU	On board Power consumption (W)
12,2						
Handset						
Max (40°)	1,57	258	2	0,34	18,46 %	200
Average (30°)	1,46	240	1	0,31	18,15 %	200
Min (16°)	1,39	228	1	0,30	18,47 %	199
Portable						
Max (40°)	1,61	264	2	0,34	18,39 %	199
Average (30°)	1,56	255	2	0,33	18,49 %	200
Min (16°)	1,49	245	1	0,32	18,45 %	199
Vehicular						
Max (40°)	1,63	267	2	0,35	18,46 %	200
Average (30°)	1,58	259	2	0,34	18,39 %	198
Min (16°)	1,54	252	1	0,33	18,45 %	200
Transportable						
Max (40°)	1,65	271	2	0,35	18,47 %	200
Average (30°)	1,63	267	2	0,35	18,39 %	197
Min (16°)	1,60	263	2	0,34	18,39 %	199

7.1.1.4 Data service 64 kbps

Table 7.4: System capacity; Data 64 kbps; Downlink

Data rate (kbps)	Capacity / carrier/ spot (Mbps)	Nb traffic codes/spot/ carrier	Nb 2 nd ary Scrambling codes/spot/ carrier	Spectrum efficiency as ITU (bit/s/Hz)	Power efficiency as ITU	On board Power consumption (W)
64						
Handset						
Max (40°)	2,82	44	1	0,60	40,03 %	195
Average (30°)	2,69	42	1	0,57	39,60 %	187
Min (16°)	2,56	40	1	0,55	39,76 %	171
Portable						
Max (40°)	2,82	44	1	0,60	40,03 %	98
Average (30°)	2,75	43	1	0,59	39,72 %	152
Min (16°)	2,69	42	1	0,57	40,10 %	166
Vehicular						
Max (40°)	2,88	45	1	0,61	40,42 %	199
Average (30°)	2,82	44	1	0,60	40,20 %	195
Min (16°)	2,75	43	1	0,59	40,23 %	191
Transportable						
Max (40°)	2,88	45	1	0,61	39,92 %	40
Average (30°)	2,82	44	1	0,60	39,77 %	25
Min (16°)	2,82	44	1	0,60	39,98 %	195

7.1.1.5 Data service 144 kbps

Table 7.5: System capacity; Data 144 kbps; Downlink

Data rate (kbps)	Capacity/ carrier/ spot	Nb traffic codes/spot/ carrier	Nb 2 nd ary Scrambling codes/spot/ carrier	Spectrum efficiency as ITU	Power efficiency as ITU	On board Power consumption
144	(Mbps)			(bit/s/Hz)		(W)
Handset						
Max (40°)	3,02	21	1	0,65	44,84 %	105
Average (30°)	2,88	20	1	0,61	44,63 %	126
Min (16°)	2,74	19	1	0,58	45,08 %	126
Portable						
Max (40°)	3,02	21	1	0,65	44,84 %	53
Average (30°)	3,02	21	1	0,65	45,14 %	132
Min (16°)	2,88	20	1	0,61	44,65 %	113
Vehicular						
Max (40°)	3,17	22	1	0,68	45,36 %	194
Average (30°)	3,02	21	1	0,65	45,14 %	83
Min (16°)	3,02	21	1	0,65	45,10 %	186
Transportable						
Max (40°)	3,17	22	1	0,68	44,59 %	61
Average (30°)	3,02	21	1	0,65	45,14 %	8
Min (16°)	3,02	21	1	0,65	45,10 %	19

7.1.1.6 Data service 384 kbps

Table 7.6: System capacity; Data 384 kbps; Downlink

Data rate (kbps)	Capacity/ carrier/ spot	Nb traffic codes/spot/ carrier	Nb 2 nd ary Scrambling codes	Spectrum efficiency as ITU	Power efficiency as ITU	On board Power consumption
384	(Mbps)			(bit/s/Hz)		(W)
Handset						
Max (40°)	3,46	9	1	0,74	44,99 %	79
Average (30°)	3,46	9	1	0,74	44,93 %	198
Min (16°)	3,07	8	1	0,66	44,64 %	100
Portable						
Max (40°)	3,46	9	1	0,74	44,99 %	39
Average (30°)	3,46	9	1	0,74	44,93 %	99
Min (16°)	3,46	9	1	0,74	44,90 %	198
Vehicular						
Max (40°)	3,46	9	1	0,74	44,99 %	25
Average (30°)	3,46	9	1	0,74	44,93 %	63
Min (16°)	3,46	9	1	0,74	44,90 %	125
Transportable						
Max (40°)	3,46	9	1	0,74	44,99 %	2
Average (30°)	3,46	9	1	0,74	44,93 %	6
Min (16°)	3,46	9	1	0,74	44,90 %	12

7.1.2 Rural environment, LOS

System capacity is given for an average of 30° elevation.

Table 7.7: System capacity; Rural LOS environment - 30° elevation; Downlink

Data rate (kbps)	Capacity/ carrier/ spot (kbps)	Nb traffic codes/spot/ Carrier	Nb 2 nd ary Scrambling codes/spot/ carrier	Spectrum efficiency as ITU (bit/s/Hz)	Power efficiency as ITU (dB)
Handset					
1,2 kbps	359	299	1	0,0766	3,71 %
4,75 kbps	857	361	1	0,1830	7,70 %
12,2 kbps	1 159	190	1	0,2474	11,26 %
64 kbps	2 304	36	1	0,4918	24,38 %
144 kbps	2 448	17	1	0,5225	27,91 %
384 kbps	2 688	7	0	0,5738	27,41 %
Portable					
1,2 kbps	373	311	1	0,0797	3,75 %
4,75 kbps	917	386	1	0,1957	7,72 %
12,2 kbps	1 244	204	1	0,2656	11,35 %
64 kbps	2 432	38	1	0,5191	24,87 %
144 kbps	2 592	18	1	0,5533	27,53 %
384 kbps	3 072	8	1	0,6557	27,59 %
Vehicular					
1,2 kbps	374	312	1	0,0799	3,74 %
4,75 kbps	924	389	1	0,1972	7,71 %
12,2 kbps	1 257	206	1	0,2682	11,39 %
64 kbps	2 432	38	1	0,5191	24,60 %
144 kbps	2 592	18	1	0,5533	27,49 %
384 kbps	3 072	8	1	0,6557	27,55 %
Transportable					
1,2 kbps	379	316	1	0,0809	3,71 %
4,75 kbps	948	399	1	0,2023	7,69 %
12,2 kbps	1 287	211	1	0,2747	11,31 %
64 kbps	2 432	38	1	0,5191	24,39 %
144 kbps	2 592	18	1	0,5533	27,53 %
384 kbps	3 072	8	1	0,6557	27,59 %

7.1.3 Sub-urban environment, LOS

System capacity is given for an average of 30° elevation.

Table 7.8: System capacity; Sub-urban LOS environment - 30° elevation; Downlink

Data rate (kbps)	Capacity/ carrier/ spot (kbps)	Nb traffic codes/spot/ Carrier	Nb 2 nd ary Scrambling codes/spot/ carrier	Spectrum efficiency as ITU (bit/s/Hz)	Power efficiency as ITU (dB)
Handset					
1,2 kbps	343	286	1	0,0733	3,05 %
4,75 kbps	793	334	1	0,1693	6,27 %
12,2 kbps	1 068	175	1	0,2279	9,18 %
64 kbps	2 240	35	1	0,4781	20,23 %
144 kbps	2 448	17	1	0,5225	22,49 %
384 kbps	2 688	7	0	0,5738	22,59 %
Portable					
1,2 kbps	355	296	1	0,0758	3,01 %
4,75 kbps	848	357	1	0,1810	6,27 %
12,2 kbps	1 141	187	1	0,2435	9,17 %
64 kbps	2 304	36	1	0,4918	19,97 %
144 kbps	2 448	17	1	0,5225	22,61 %
384 kbps	2 688	7	0	0,5738	22,54 %
Vehicular					
1,2 kbps	358	298	1	0,0763	3,05 %
4,75 kbps	853	359	1	0,1820	6,23 %
12,2 kbps	1 153	189	1	0,2461	9,24 %
64 kbps	2 304	36	1	0,4918	20,27 %
144 kbps	2 448	17	1	0,5225	22,71 %
384 kbps	2 688	7	0	0,5738	22,42 %
Transportable					
1,2 kbps	362	302	1	0,0774	3,03 %
4,75 kbps	876	369	1	0,1871	6,24 %
12,2 kbps	1 183	194	1	0,2526	9,21 %
64 kbps	2 368	37	1	0,5055	20,15 %
144 kbps	2 592	18	1	0,5533	22,66 %
384 kbps	3 072	8	1	0,6557	22,27 %

7.1.4 Urban environment, LOS

System capacity is given for an average of 30° elevation.

Table 7.9: System capacity; Urban LOS environment - 30° elevation; Downlink

Data rate (kbps)	Capacity/ carrier/ spot (kbps)	Nb traffic codes/spot/ Carrier	Nb 2 nd ary Scrambling codes/spot/ carrier	Spectrum efficiency as ITU (bit/s/Hz)	Power efficiency as ITU (dB)
Handset (30°)					
1,2 kbps	313	261	1	0,0669	1,77 %
4,75 kbps	677	285	1	0,1445	3,68 %
12,2 kbps	897	147	1	0,1914	5,37 %
64 kbps	1 984	31	0	0,4235	11,77 %
144 kbps	2 160	15	0	0,4611	13,31 %
384 kbps	2 688	7	0	0,5738	13,17 %
Portable					
1,2 kbps	325	271	1	0,0694	1,78 %
4,75 kbps	724	305	1	0,1546	3,69 %
12,2 kbps	964	158	1	0,2057	5,46 %
64 kbps	2 112	33	1	0,4508	11,67 %
144 kbps	2 304	16	1	0,4918	13,28 %
384 kbps	2 688	7	0	0,5738	13,14 %
Vehicular					
1,2 kbps	326	272	1	0,0697	1,77 %
4,75 kbps	729	307	1	0,1556	3,66 %
12,2 kbps	970	159	1	0,2070	5,45 %
64 kbps	2 112	33	1	0,4508	11,91 %
144 kbps	2 304	16	1	0,4918	13,27 %
384 kbps	2 688	7	0	0,5738	13,26 %
Transportable					
1,2 kbps	331	276	1	0,0707	1,76 %
4,75 kbps	751	316	1	0,1602	3,69 %
12,2 kbps	994	163	1	0,2122	5,38 %
64 kbps	2 112	33	1	0,4508	11,93 %
144 kbps	2 304	16	1	0,4918	13,28 %
384 kbps	2 688	7	0	0,5738	13,14 %

7.1.5 Mobile environment without LOS and/or indoor penetration

System capacity is given for an average of 30° elevation. Link margin is set to 15 dB.

Table 7.10: System capacity; Mobile environment without LOS/indoor penetration - 30° elevation; Downlink

Data rate (kbps)	Capacity/carrier/spot (kbps)	Nb traffic codes/spot/Carrier	Spectrum efficiency as ITU (bit/s/Hz)	Power efficiency as ITU (dB)
Handset				
1,2 kbps	2	2	0,0005	0,39 %
4,75 kbps	64	27	0,0137	0,39 %
12,2 kbps	92	15	0,02	0,59 %
Portable				
1,2 kbps	50	42	0,0108	0,38 %
4,75 kbps	157	66	0,0335	0,39 %
12,2 kbps	183	30	0,04	0,58 %
Vehicular				
1,2 kbps	59	49	0,0126	0,38 %
4,75 kbps	173	73	0,0370	0,39 %
12,2 kbps	244	40	0,05	0,58 %
64 kbps	128	2	0,03	1,28 %
Transportable				
1,2 kbps	96	80	0,0205	0,38 %
4,75 kbps	295	124	0,0629	0,40 %
12,2 kbps	427	70	0,09	0,58 %
64 kbps	320	5	0,07	1,27 %
144 kbps	288	2	0,06	1,43 %

7.1.6 Combined satellite and IMR environment

System capacity is given for an average of 30° elevation.

Table 7.11: System capacity; IMR deployment; Downlink

Data rate (kbps)	Capacity/carrier/spot (kbps)	Nb traffic codes/spot/carrier	Spectrum efficiency as ITU (bit/s/Hz)	Power efficiency as ITU (dB)
Handset				
1,2 kbps	329	274	0,0702	2,43 %
4,75 kbps	703	296	0,1501	4,26 %
12,2 kbps	946	155	0,2018	6,46 %
64 kbps	1 984	31	0,4235	11,77 %
144 kbps	2 160	15	0,4611	12,39 %
384 kbps	1 920	5	0,4098	9,43 %
Portable				
1,2 kbps	342	285	0,0730	2,46 %
4,75 kbps	755	318	0,1612	4,33 %
12,2 kbps	1 013	166	0,2161	6,48 %
64 kbps	2 112	33	0,4508	11,67 %
144 kbps	2 304	16	0,4918	12,75 %
384 kbps	2 688	7	0,5738	9,35 %
Vehicular				
1,2 kbps	343	286	0,0733	2,45 %
4,75 kbps	760	320	0,1622	4,30 %
12,2 kbps	1 019	167	0,2174	6,45 %
64 kbps	2 112	33	0,4508	11,91 %
144 kbps	2 304	16	0,4918	13,27 %
384 kbps	2 688	7	0,5738	13,26 %
Transportable				
1,2 kbps	348	290	0,0743	2,45 %
4,75 kbps	781	329	0,1668	4,32 %
12,2 kbps	1 049	172	0,2240	6,49 %
64 kbps	2 112	33	0,4508	11,93 %
144 kbps	2 304	16	0,4918	11,98 %
384 kbps	2 688	7	0,5738	13,14 %

7.2 Uplink

The system capacity results presented hereafter were calculated with the assumption MUD is implemented, except for data service 1,2 kbps.

In all the subsequent tables, the empty compartments indicate situations when the service can not be offered due to link budget failure (link margin not reached due to UE power and antenna gain limitations).

7.2.1 Static environment

7.2.1.1 Data service 1,2 kbps

Table 7.12: System capacity; Data service 1,2 kbps; Uplink

Data rate (kbps) 1,2	Capacity/ carrier/ spot (kbps)	Nb traffic codes/spot/ carrier	Spectrum efficiency as ITU (bit/s/Hz)	Power efficiency as ITU
Handset				
Max (40°)	352,8	294	0,0753	17,97 %
Average (30°)	283,2	236	0,0605	17,98 %
Min (16°)	212,4	177	0,0453	17,97 %
Portable				
Max (40°)	409,2	341	0,0873	18,01 %
Average (30°)	399,6	333	0,0853	17,99 %
Min (16°)	388,8	324	0,0830	17,96 %
Vehicular				
Max (40°)	412,8	344	0,0881	17,99 %
Average (30°)	408,0	340	0,0871	17,99 %
Min (16°)	402,0	335	0,0858	17,98 %
Transportable				
Max (40°)	412,8	344	0,0881	17,97 %
Average (30°)	409,2	341	0,0873	18,00 %
Min (16°)	403,2	336	0,0861	17,97 %

7.2.1.2 Speech service 4,75 kbps

Table 7.13: System capacity; Speech 4,75 kbps; Uplink

Data rate (kbps) 4,75	Capacity/ carrier/ spot (kbps)	Nb traffic codes/spot/ carrier	Spectrum efficiency as ITU (bit/s/Hz)	Power efficiency as ITU
Handset				
Max (40°)	862,1	363	0,0920	47,92 %
Average (30°)	589,0	248	0,0629	47,83 %
Min (16°)	315,9	133	0,0337	47,83 %
Portable				
Max (40°)	919,1	387	0,0981	40,81 %
Average (30°)	919,1	387	0,0981	42,12 %
Min (16°)	919,1	387	0,0981	43,56 %
Vehicular				
Max (40°)	919,1	387	0,0981	40,12 %
Average (30°)	919,1	387	0,0981	40,66 %
Min (16°)	919,1	387	0,0981	41,31 %
Transportable				
Max (40°)	919,1	387	0,0981	40,04 %
Average (30°)	919,1	387	0,0981	40,50 %
Min (16°)	919,1	387	0,0981	41,06 %

7.2.1.3 Speech service 12,2 kbps

Table 7.14: System capacity; Speech 12,2 kbps; Uplink

Data rate (kbps) 12,2	Capacity/ carrier/ spot (kbps)	Nb traffic codes/spot/ carrier	Spectrum efficiency as ITU (bit/s/Hz)	Power efficiency as ITU
Handset				
Max (40°)	305,0	50	0,0326	39,79 %
Average (30°)	-	-	-	-
Min (16°)	-	-	-	-
Portable				
Max (40°)	768,6	126	0,0820	35,38 %
Average (30°)	768,6	126	0,0820	38,05 %
Min (16°)	744,2	122	0,0794	39,79 %
Vehicular				
Max (40°)	768,6	126	0,0820	33,60 %
Average (30°)	768,6	126	0,0820	34,30 %
Min (16°)	768,6	126	0,0820	35,10 %
Transportable				
Max (40°)	768,6	126	0,0820	33,40 %
Average (30°)	768,6	126	0,0820	33,88 %
Min (16°)	768,6	126	0,0820	34,45 %

7.2.1.4 Data service 64 kbps

Table 7.15: System capacity; Data 64 kbps; Uplink

Data rate (kbps) 64	Capacity/ carrier/ spot (kbps)	Nb traffic codes/spot/ carrier	Spectrum efficiency as ITU (bit/s/Hz)	Power efficiency as ITU
Handset				
Max (40°)	-	-	-	-
Average (30°)	-	-	-	-
Min (16°)	-	-	-	-
Portable				
Max (40°)	1 984,0	31	0,4235	79,26 %
Average (30°)	1 664,0	26	0,3552	78,49 %
Min (16°)	1 344,0	21	0,2869	77,86 %
Vehicular				
Max (40°)	2 176,0	34	0,4645	78,47 %
Average (30°)	2 112,0	33	0,4508	78,52 %
Min (16°)	2 048,0	32	0,4372	78,76 %
Transportable				
Max (40°)	2 176,0	34	0,4645	77,59 %
Average (30°)	2 176,0	34	0,4645	79,03 %
Min (16°)	2 112,0	33	0,4508	78,30 %

7.2.1.5 Data service 144 kbps

Table 7.16: System capacity; Data 144 kbps; Uplink

Data rate (kbps) 144	Capacity/ carrier/ spot (kbps)	Nb traffic codes/spot/ carrier	Spectrum efficiency as ITU (bit/s/Hz)	Power efficiency as ITU
Handset				
Max (40°)	-	-	-	-
Average (30°)	-	-	-	-
Min (16°)	-	-	-	-
Portable				
Max (40°)	2 592,0	18	0,5533	95,30 %
Average (30°)	2 016,0	14	0,4303	97,78 %
Min (16°)	1 296,0	9	0,2766	95,88 %
Vehicular				
Max (40°)	3 024,0	21	0,6455	93,75 %
Average (30°)	3 024,0	21	0,6455	97,85 %
Min (16°)	2 880,0	20	0,6148	97,64 %
Transportable				
Max (40°)	3 168,0	22	0,6762	96,59 %
Average (30°)	3 168,0	22	0,0000	98,84 %
Min (16°)	3 024,0	21	0,6455	96,74 %

7.2.1.6 Data service 384 kbps

Table 7.17: System capacity; Data 384 kbps; Uplink

Data rate (kbps) 384	Capacity/ carrier/ spot (kbps)	Nb traffic codes/spot/ carrier	Spectrum efficiency as ITU (bit/s/Hz)	Power efficiency as ITU
Handset				
Max (40°)	-	-	-	-
Average (30°)	-	-	-	-
Min (16°)	-	-	-	-
Portable				
Max (40°)	1 920,0	5	0,0000	96,86 %
Average (30°)	-	-	-	-
Min (16°)	-	-	-	-
Vehicular				
Max (40°)	3 072,0	8	0,6557	92,73 %
Average (30°)	2 688,0	7	0,5738	89,88 %
Min (16°)	2 304,0	6	0,4918	87,19 %
Transportable				
Max (40°)	3 072,0	8	0,6557	88,18 %
Average (30°)	3 072,0	8	0,6557	92,51 %
Min (16°)	3 072,0	8	0,0000	97,16 %

7.2.2 Rural environment, LOS

System capacity is calculated for satellite ITU Model A LOS situations, i.e. for a propagation margin set to 1,2 dB, for an average 30° UE elevation.

Service is not provided to handset UE configuration. Data rates not indicated in table 7.18 are those which are not supported in rural environment due to lack propagation margin.

Table 7.18: System capacity; Rural LOS environment; 30° elevation; Uplink

Data rate (kbps)	Capacity/carrier/spot (kbps)	Nb traffic codes/spot/carrier	Spectrum efficiency as ITU (bit/s/Hz)	Power efficiency as ITU dB
Handset				
1,2 kbps	184,8	154	0,0394	13,64 %
4,75 kbps	327,75	138	0,0350	36,32 %
Portable				
1,2 kbps	301,2	251	0,0643	13,66 %
4,75 kbps	788,5	332	0,0842	36,37 %
12,2 kbps	585,6	96	0,0625	29,99 %
64 kbps	1 152,0	18	0,2459	59,66 %
144 kbps	1 296,0	9	0,2766	74,87 %
Vehicular				
1,2 kbps	309,6	258	0,0661	13,66 %
4,75 kbps	819,4	345	0,0875	36,27 %
12,2 kbps	671,0	110	0,0716	30,00 %
64 kbps	1 600,0	25	0,3415	59,69 %
144 kbps	2 304,0	16	0,4918	74,94 %
384 kbps	1 920,0	5	0,4098	65,44 %
Transportable				
1,2 kbps	309,6	258	0,0661	13,61 %
4,75 kbps	824,1	347	0,0880	36,31 %
12,2 kbps	683,2	112	0,0729	30,12 %
64 kbps	1 664,0	26	0,3552	60,19 %
144 kbps	2 304,0	16	0,4918	71,35 %
384 kbps	2 304,0	6	0,4918	68,07 %

7.2.3 Sub-urban environment, LOS

System capacity is calculated for satellite ITU Model B LOS situations, i.e. for a propagation margin set to 1,8 dB, for an average 30° UE elevation.

Service is not provided to handset UE configuration. Data rates not indicated in table 7.19 are those which are not supported in sub-urban environment due to lack propagation margin.

Table 7.19: System capacity. Sub-urban LOS environment; 30° elevation; Uplink

Data rate (kbps)	Capacity/carrier/spot (kbps)	Nb traffic codes/spot/carrier	Spectrum efficiency as ITU (bit/s/Hz)	Power efficiency as ITU dB
Handset				
1,2 kbps	122,4	102	0,0261	10,90 %
4,75 kbps	220,875	93	0,0236	31,61 %
Portable				
1,2 kbps	238,8	199	0,0510	10,91 %
4,75 kbps	679,3	286	0,0725	31,56 %
12,2 kbps	500,2	82	0,0534	26,23 %
64 kbps	960,0	15	0,2049	52,59 %
144 kbps	1 008,0	7	0,2152	65,71 %
Vehicular				
1,2 kbps	247,2	206	0,0528	10,91 %
4,75 kbps	712,5	300	0,0760	31,56 %
12,2 kbps	585,6	96	0,0625	26,24 %
64 kbps	1 408,0	22	0,3005	52,63 %
144 kbps	2 016,0	14	0,4303	65,78 %
384 kbps	1 920,0	5	0,4098	65,44 %
Transportable				
1,2 kbps	248,4	207	0,0530	10,92 %
4,75 kbps	717,3	302	0,0766	31,60 %
12,2 kbps	597,8	98	0,0638	26,36 %
64 kbps	1 472,0	23	0,3142	53,13 %
144 kbps	2 016,0	14	0,4303	62,18 %
384 kbps	1 920,0	5	0,4098	55,85 %

7.2.4 Urban environment, LOS

System capacity is calculated for satellite ITU Model C LOS situations, i.e. for a propagation margin set to 3,3 dB, for an average 30° UE elevation.

Service is not provided to handset UE configuration. Data rates not indicated in table 7.20 are those which are not supported in Urban environment due to lack of propagation margin.

Table 7.20: System capacity; Urban LOS environment; 30° elevation; Uplink

Data rate (kbps)	Capacity/ carrier/ spot (kbps)	Nb traffic codes/spot/ carrier	Spectrum efficiency as ITU (bit/s/Hz)	Power efficiency as ITU dB
Handset				
1,2 kbps	50,4	42	0,0108	7,72 %
4,75 kbps	11,875	5	0,0013	22,41 %
Portable				
1,2 kbps	166,8	139	0,0356	7,74 %
4,75 kbps	470,3	198	0,0502	22,35 %
12,2 kbps	329,4	54	0,0352	18,71 %
64 kbps	512,0	8	0,1093	36,12 %
144 kbps	432,0	3	0,0922	47,38 %
Vehicular				
1,2 kbps	174,0	145	0,0371	7,68 %
4,75 kbps	503,5	212	0,0537	22,35 %
12,2 kbps	414,8	68	0,0443	18,72 %
64 kbps	960,0	15	0,2049	36,15 %
144 kbps	1 296,0	9	0,2766	42,87 %
384 kbps	1 152,0	3	0,2459	41,01 %
Transportable				
1,2 kbps	175,2	146	0,0374	7,69 %
4,75 kbps	508,3	214	0,0542	22,40 %
12,2 kbps	420,9	69	0,0449	18,57 %
64 kbps	1 024,0	16	0,2186	36,65 %
144 kbps	1 440,0	10	0,3074	43,85 %
384 kbps	1 536,0	4	0,3279	43,63 %

7.2.5 Combined satellite and IMR environment

System capacity is foreseen to be similar to 3GPP terrestrial capacity. To be checked.

8 Technology design constraints

8.1 Doppler frequency shift

8.1.1 Doppler shift due to satellite movement

Considering the GEO satellite configuration case and a speed of 3 m/s for the movement of the satellite, which correspond to a stabilization of the North-South inclination of about 0,07° and $\cos(\alpha) = 1$, the maximum Doppler frequency shift is calculated at upper limit of each MSS frequency band.

Table 8.1: Maximum Doppler frequency shift due to satellite movement (GEO case)

Frequency band	Core Band	
	MSS uplink	MSS downlink
Maximum Doppler frequency shift	22 Hz	20,1 Hz

The Doppler frequency shift due to the GEO satellite movement is negligible to be compared to the one due to UE movement (see next clause). Thus it can easily be compensated with standard 3GPP chipsets.

8.1.2 Doppler shift due to UE movement

Depending on the maximum UE speed, the maximum Doppler frequency shift is as follows (at upper limit of each MSS frequency band).

Table 8.2: Maximum Doppler frequency shift due to UE movement

Frequency band	Core Band	
	MSS uplink	MSS downlink
Maximum Doppler frequency shift		
5 000 km/h (aeronautical future)	10 185 Hz	9 320 Hz
1 000 km/h (aeronautical)	2 036 Hz	1 864 Hz
500 km/h	1 018 Hz	930 Hz
120 km/h	244 Hz	223 Hz
3 km/h	6 Hz	5,6 Hz

The most constraining is aeronautical environment concerning Doppler frequency shift. This constraints may drive to add a Doppler compensation module to the UE and the gateway for use in aeronautical environment.

8.2 Interoperability

8.2.1 Dual mode UEs

To use W-CDMA UTRA FDD in the satellite environment means essential parameters are made common between satellite and terrestrial systems. Consequently, most of RF and base-band circuits in the UE can be shared by the two operation modes. The UE antenna is also shared by the two operation modes for the handset configuration. This allows for small and light-weight dual mode UEs.

Dual mode UEs with 2nd generation systems, e.g. GSM or GMR and 2nd generation services are supported by the proposed RTT.

8.2.2 Intermediate Module Repeaters

IMR implementation may be based on terrestrial Node B equipment. Co-location with terrestrial Node Bs is possible for system deployment integration.

8.2.3 Inter-system handover

The proposed RTT eases inter-system handover:

- with 2nd generation systems (e.g. GSM or GMR) thanks to compressed mode;
- with terrestrial UMTS thanks to the use of the same radio interface (same waveform, same protocol architecture).

8.2.4 Compatibility with existing systems

Since the radio interface of the proposed RTT is not new but based on terrestrial UMTS, it is highly recommended to re-use terrestrial UMTS components.

Furthermore, it presents no problem for connection to terrestrial 3GPP equipment thanks to the use of standardized transport interfaces: Iub, Iur and Iu interfaces are kept unchanged from 3GPP standards.

8.3 Performance enhancement features

For the space segment, communication payload on-board satellite may implement techniques that enhance system performance, e.g.:

- Transparent analog connectivity between spots and/or frequency channels: this allows connectivity between coverage areas, thus allowing single satellite hop communications (no necessity for signal transition to the gateway).
- Regenerative payload: On-board base band processing signal demodulation/re-modulation and decoding/re-encoding may be implemented in order to increase link level performance. Link budget calculations (see annex C) show that the feeder link has little impact on link level performance. Thus regenerative payload seems to be of interest in case on-board connectivity only.

For the terrestrial segment, candidate techniques for system performance enhancement are:

- Additionally to Multi User Detection which feasibility is commonly agreed for the uplink direction, applicability to the downlink direction is being considered. In effect, implementing interference cancellation at the UE receiver means to inform the UE about scrambling code, thus for adjacent spot interference cancellation. A major focus is to be pointed on the implementation cost of the UE.
- Receiver diversity at the UE level, i.e. dual antenna at UE, for portable, vehicular and transportable configurations.
- Time diversity.
- Higher level modulation for the downlink direction can be considered, with restriction due to the limited satellite power capacity.
- Optimized code allocation strategy.

8.4 System flexibility

The radio interface allows for system flexibility such as:

- Dynamic spot redirection: a spot coverage may be redirected to a regional area where more capacity is required.
- Dynamic spot power redistribution: satellite power can be redistributed between spots according to varying capacity requirement.
- Satellite diversity.

9 Conclusion

The present document has presented the feasibility of using W-CDMA as a satellite radio interface. The main system characteristics can be summarized as:

- satellite UMTS based on W-CDMA can help to improve utilization of terrestrial capacity;
- UMTS terrestrial networks interoperability;
- full frequency re-use in all beams and satellites;
- large area coverage, particularly convenient for services such as broadcast/multicast services;
- suitable to complement terrestrial coverage and services in areas where:
 - terrestrial systems have not been deployed for business attractiveness reasons; or
 - terrestrial coverage requires capacity complement; or
 - terrestrial system has suffered environmental damages (crisis conditions),
- re-use of terrestrial equipment, which allows economies of scale;
- Intermediate Module Repeaters, located LOS to the satellite, can extend the coverage area to urban and indoor environment, in the MSS frequency band;
- line of sight is recommended in the absence of Intermediate Module Repeaters and satellite diversity for providing full system capacity;
- in the absence of Intermediate Module Repeaters, possibility of limited indoor penetration;
- applicable to several satellite constellation types (for LEO and MEO constellations, addition of doppler and synchronization adaptation module);
- system capacity considerably increased for UEs equipped with external module implementing power amplifier and optimized antenna;
- configurations with reduced system capacity (e.g. handset UE configuration in urban environment) show that the system can anyway be used for Public Protection Disaster Relief.

The adaptations which are expected from UE implementation for operation in satellite environment are:

- RF agility to MSS frequency.
- For PRACH procedure, introduction of a delay for AICH reception. As an option, transmission synchronization with a GNSS reference.
- Layer 2 protocol timers: adaptation to satellite propagation delay.

The adaptations which are expected from Node B base-band implementation for operation in satellite environment are:

- Enlarged Reception window for PRACH preamble detection in case no GNSS UE physical layer synchronization.

Annex A: Downlink Reference measurement channels

A.1 Data service 1,2 kbps

This test service is data service at 1,2 kbps. The parameters for the 1,2 kbps speech service are specified in Table A.1. the channel coding is shown in Figure A.1 for information.

Table A.1: Parameters for 1,2 kbps test service; Downlink

Parameter	Unit	Level
Information bit rate	kbps	4,75
DPCH	ksps	15
Slot Format #i	-	5
TFCI	-	On
Power offsets PO1, PO2 and PO3	dB	0
Puncturing	%	16,67
Parameter	DTCH	DCCH
Transport Channel Number	1	-
Transport Block Size	24	-
Transport Block Set Size	24	-
Transmission Time Interval	20 ms	-
Type of Error Protection	Convolution Coding	-
Coding Rate	1/3	-
Rate Matching attribute	256	-
Size of CRC	16	-
Position of TrCH in radio frame	Fixed	-

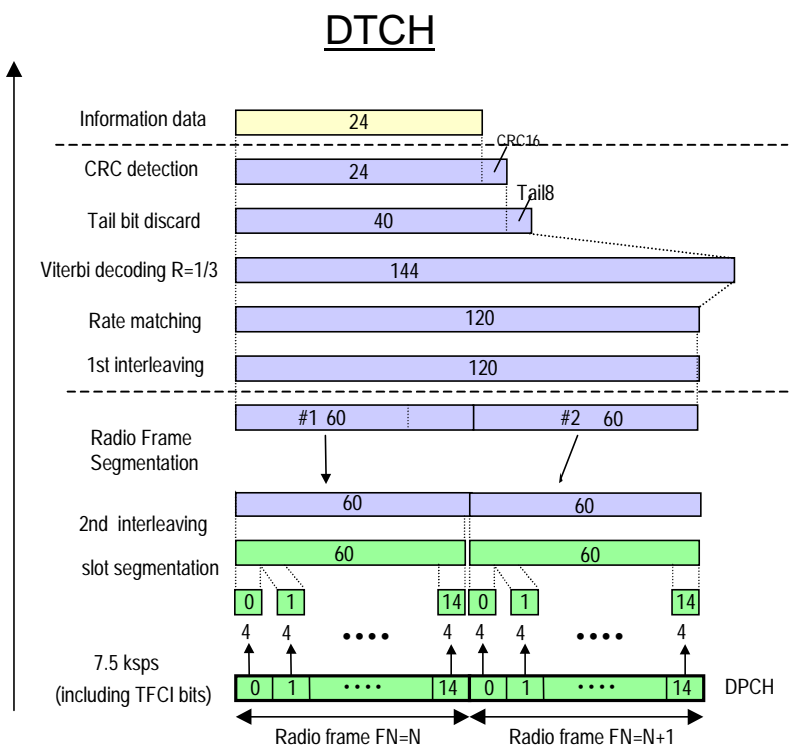

Figure A.1: Channel coding and multiplexing example for 1,2 kbps data; Downlink

A.2 Speech 4,75 kbps

This test service is 3GPP standardized AMR speech service at 4,75 kbps. The parameters for the 4,75 kbps speech service are specified in Table A.2. the channel coding is is shown in Figure A.2 for information.

Table A.2: Parameters for 4,75 kbps test service; Downlink

Parameter	Unit	Level
Information bit rate	kbps	4,75
DPCH	ksps	15
Slot Format #i	-	5
TFCI	-	On
Power offsets PO1, PO2 and PO3	dB	0
Puncturing	%	26,61
Parameter	DTCH	DCCH
Transport Channel Number	1	2
Transport Block Size	95	30
Transport Block Set Size	95	30
Transmission Time Interval	20 ms	40 ms
Type of Error Protection	Convolution Coding	Convolution Coding
Coding Rate	1/3	1/3
Rate Matching attribute	256	256
Size of CRC	16	12
Position of TrCH in radio frame	fixed	Fixed

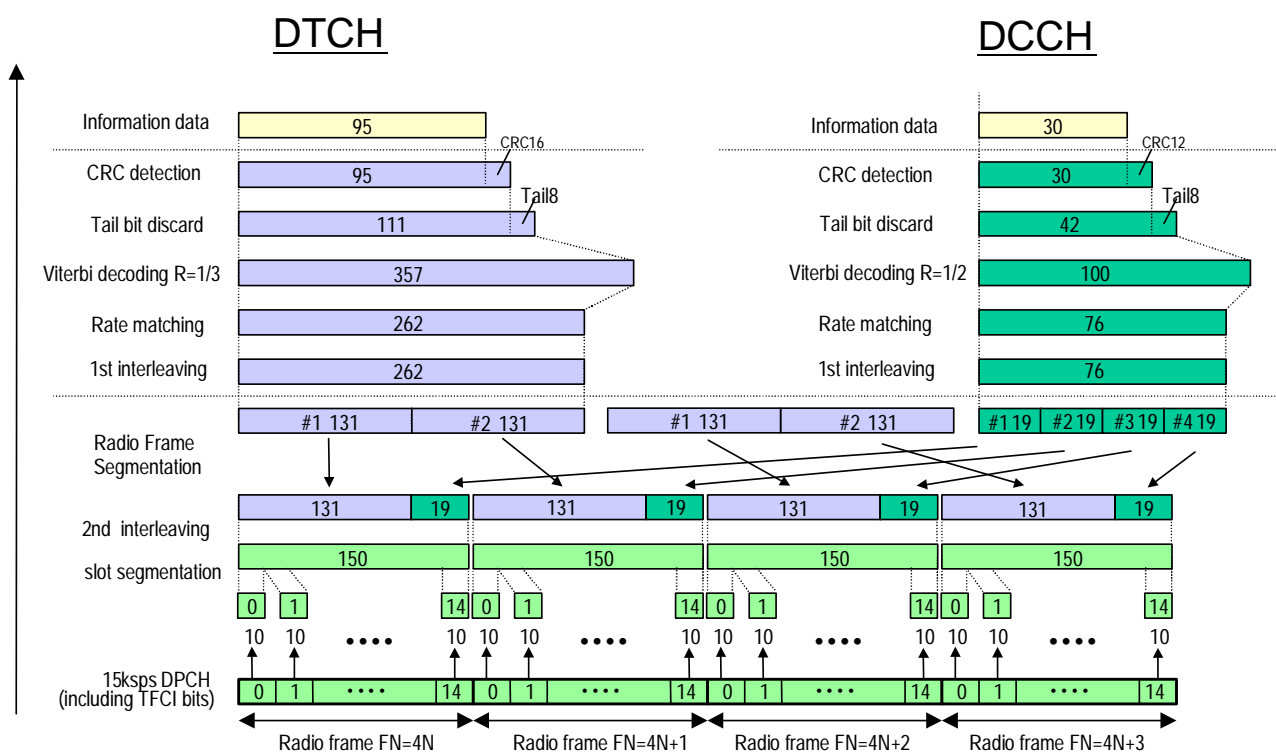

Figure A.2: Channel coding and multiplexing example for 4,75 kbps data; Downlink

Annex B: Uplink Reference measurement channels

B.1 Data service 1,2 kbps

B.2 Speech 4,75 kbps

This test service is speech service at 4,75 kbps. The parameters for the 4,75 kbps speech service are specified in Table A.2. the channel coding is shown in Figure A.2 for information.

Table B.1: Parameters for 4,75 kbps test service; Uplink

Parameter	Level	Unit
Information bit rate	4,75	kbps
DPCH	30	kbps
Power control	Off	
TFCI	On	
Repetition		%

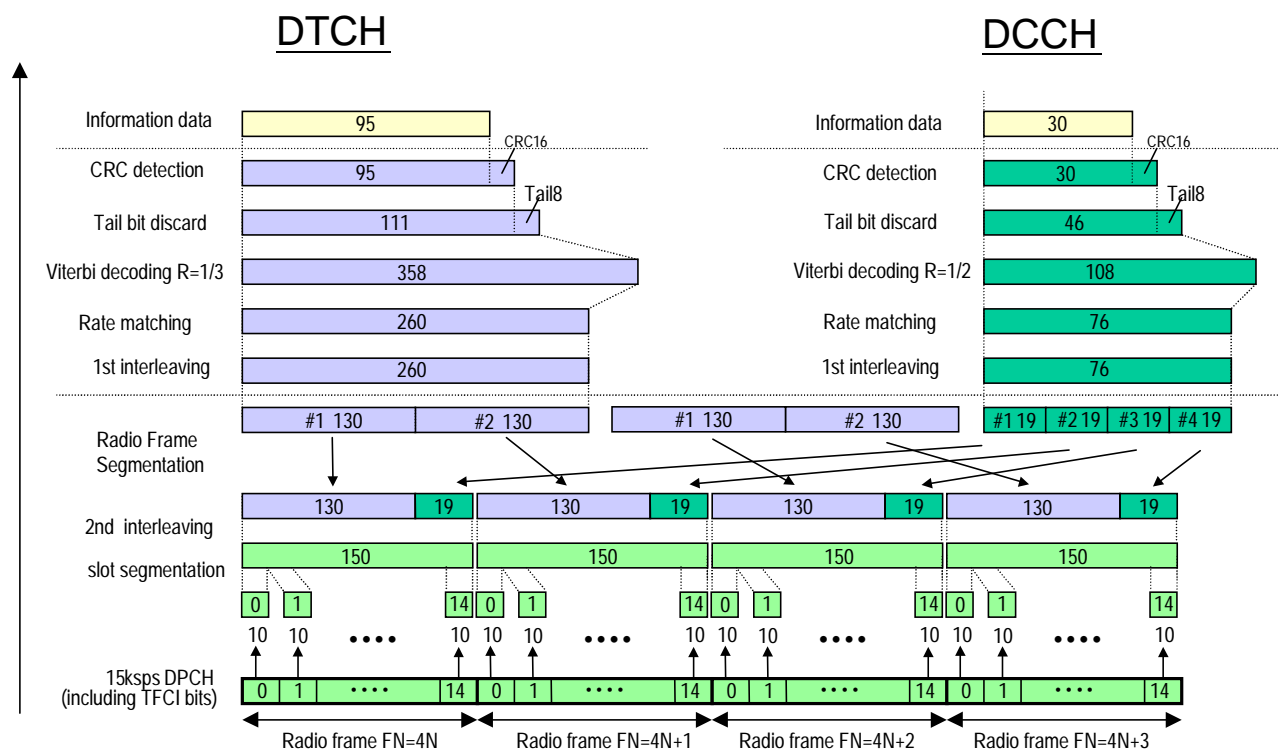

Figure B.1: Channel coding and multiplexing example for 4,75 kbps data; Uplink

Annex C: Link budgets

Link budgets are evaluated for GEO constellation, extended multi-beam configuration i.e. 30 spots for a European coverage. Satellite is at an altitude in the range of 36 000 km, which means free space loss near to 192 dB.

It is assumed every spot is equally traffic loaded (uniform traffic distribution).

It is assumed the Eb/Nt feeder link degradation is kept less than 0,2 dB [1].

Link budgets are calculated for a Block Error Ratio (BLER) less than 10^{-2} in AWGN channel conditions, i.e. static conditions. In case of speech 12,2 kbps service, an activity factor of 0,5 is assumed.

Design margin is included in Eb/Nt (see clauses 6.2.3.2 and 6.2.4.2). For that reason, link budgets are calculated with a null margin.

In case of handset terminal, body loss is taken into account (1 dB).

Link budgets were also calculated for mobile environment, i.e. taking into account propagation margin. Impact on system capacity for mobile environment is presented in clause 6.1.

No satellite diversity is applied, there is only one satellite in view.

For adjacent spot interference calculation, it is assumed that all the spots serve an equivalent number of codes.

The design margin required for link budgets calculation is included in Eb/Nt. For this reason, link budgets are presented with a null link margin.

Link budgets are evaluated for four UE configurations:

Table C.1: UE link budget EIRP and G/T

UE type	Power class	Maximum gain	Maximum EIRP	G/T
Handheld	250 mW	0 dBi	-6 dBW	-24,6 dB/°K
Portable	2 W	2 dBi	5 dBW	-21 dB/°K
Vehicular	8 W	4 dBi	13 dBW	-20 dB/°K
Transportable	2 W	14 dBi	17 dBW	-9 dB/°K

C.1 Downlink

Satellite bus power dedicated to the W-CDMA mission is limited to 18 kW max. Considering a 33 % efficiency for multi-carrier operation, this allows for 200 W on-board power per spot.

The levels of power flux density (pfd) are kept below thresholds set by ITU frequency sharing recommendations [33], i.e.:

- UE elevation = 42° and 30° → pfd ≤ -118 dBW/m²/MHz.
- UE elevation = 16° → pfd ≤ -122,5 dBW/m²/MHz.

The downlink capacity is limited by:

- On board power.
- Downlink interference.
- The maximum number of downlink channelization (due to the codes tree allocation scheme) and scrambling codes (1 primary scrambling code + max. 15 secondary scrambling codes) [15].

In case secondary downlink scrambling codes are used, sets of channelization codes under different scrambling codes are not orthogonal against each other. This is taken into account for interference calculation.

It is assumed the satellite is geostionnary, equipped with a 12 m diameter antenna. Polarization is circular. System temperature is 550°K.

The link budgets are evaluated with the common parameters summarized below:

Table C.2: Downlink link budget common parameters

Satellite				
Satellite Location	°E	13		
Orbital Height	Km	35786		
Average No. of Overlapping Satellites		1		
Service Downlink				
Number of FDM's		1		
Number of Satellite Beams		30		
Chip Rate	Mchip/s	3,840		
Chip SRC Roll-off Factor		0,22		
Full FDM Bandwidth	MHz	4,68		
Downlink Frequency	MHz	2185		
Availability (/year)	%	99,90		
Polarization (C/V/H)	C/V/H	Circular		
OBO (@TWTA level)	dB	1,3		
Polarization and Pointing Losses	dB	0,5		
UT System Temp.	°K	290,0		
Eb/No Losses due to Satellite Non-Linear	dB	1,5		
UE Elevation	deg.	42	30	16
Slant Range	Km	37629,1	38611,7	39957,9
Tx Antenna Gain	dB	47,0	44,0	42,5
Satellite Antenna C/I	dB	14,0	13,0	12,0
Free Space Losses	dB	190,7	191,0	191,3

C.1.1 Data service 1,2 kbps

Table C.3: Downlink budget; Data service 1,2 kbps

FORWARD LINK BUDGET		Handset 0 dBi			Portable			Vehicular			Transportable		
UE elevation	deg.	42	30	16	42	30	16	42	30	16	42	30	16
Data Rate	bit/s	1 200	1 200	1 200	1 200	1 200	1 200	1 200	1 200	1 200	1 200	1 200	1 200
Traffic Activity Factor		1,0	1,0	1,0	1,0	1,0	1,0	1,0	1,0	1,0	1,0	1,0	1,0
Required Eb/(No+Io) per Finger	dB	9,19	9,19	9,19	9,19	9,19	9,19	9,19	9,19	9,19	9,19	9,19	9,19
On Board Power/FACH/Beam/FDM	dBW	-6,05	-5,87	-5,75	-6,10	-6,05	-5,95	-6,10	-6,10	-6,00	-6,20	-6,20	-6,05
On Board EIRP/FACH/Beam/FDM	dBW	40,95	38,13	36,75	40,90	37,95	36,55	40,90	37,90	36,50	40,80	37,80	36,45
CPICH EIRP / Beam / FDM	dBW	55,81	52,99	51,61	55,76	52,81	51,41	55,76	52,76	51,36	55,66	52,66	51,31
P-CCPCH EIRP / Beam / FDM	dBW	53,81	50,99	49,61	53,76	50,81	49,41	53,76	50,76	49,36	53,66	50,66	49,31
SCH EIRP / Beam / FDM	dBW	53,81	50,99	49,61	53,76	50,81	49,41	53,76	50,76	49,36	53,66	50,66	49,31
PICH EIRP / Beam / FDM	dBW	50,81	47,99	46,61	50,76	47,81	46,41	50,76	47,76	46,36	50,66	47,66	46,31
Common Physical Channels	-	78,94	78,94	78,94	78,94	78,94	78,94	78,94	78,94	78,94	78,94	78,94	78,94
Equivalent Traffic Codes													
On Board Power / Beam / FDM	dB	23,0	23,0	23,0	23,0	23,0	23,0	23,0	22,9	22,9	22,9	22,9	23,0
On Board power Density	dB/Hz	-43,7	-43,7	-43,7	-43,7	-43,7	-43,7	-43,7	-43,8	-43,8	-43,8	-43,8	-43,7
On board EIRP / Beam / FDM	dBW	70,0	67,0	65,5	70,0	67,0	65,5	70,0	66,9	65,4	69,9	66,9	65,5
On Board Power / Beam	W	198,6	199,8	197,9	199,6	197,9	198,4	199,8	196,4	197,2	196,5	194,5	198,6
Saturated Power / Beam	W	268,0	269,5	267,0	269,2	266,9	267,7	269,5	264,9	266,0	265,0	262,4	268,0
Saturated On Board EIRP / Beam	dBW	71,3	68,3	66,8	71,3	68,3	66,8	71,3	68,2	66,7	71,2	68,2	66,8
Losses (free space, polarization, pointing and body)	dB	192,2	192,5	192,8	191,2	191,5	191,8	191,2	191,5	191,8	191,2	191,5	191,8
UE Antenna Gain	dB	0	0	0	2	2	2	4	4	4	14	14	14
UE G/T	dB/K	-24,6	-24,6	-24,6	-21,0	-21,0	-21,0	-20,0	-20,0	-20,0	-9,0	-9,0	-9,0
Thermal Noise Density, No	dBW/Hz	-204,0	-204,0	-204,0	-205,6	-205,6	-205,6	-204,6	-204,6	-204,6	-205,6	-205,6	-205,6
Interference from secondary scrambling codes	dBW	-128,0	-131,7	-134,1	-124,8	-128,3	-130,4	-122,8	-126,3	-128,3	-112,8	-116,2	-118,1
Interference from adjacent spot	dBW	-136,3	-138,5	-139,3	-133,2	-135,5	-136,3	-131,2	-133,5	-134,3	-121,3	-123,6	-124,3
Total interference per channel	dBW	-127,4	-130,9	-133,0	-124,3	-127,6	-129,4	-122,2	-125,6	-127,4	-112,2	-115,5	-117,1
-10*LOG(Spreading Bandwidth)	dB/Hz	-65,8	-65,8	-65,8	-65,8	-65,8	-65,8	-65,8	-65,8	-65,8	-65,8	-65,8	-65,8
Interference Density, Io	dBW/Hz	-193,3	-196,7	-198,8	-190,1	-193,4	-195,2	-188,1	-191,4	-193,2	-178,1	-181,3	-183,0
10*log(No+Io)	dBW/Hz	-192,9	-196,0	-197,7	-190,0	-193,2	-194,8	-188,0	-191,2	-192,9	-178,1	-181,3	-183,0
Rx Power Flux Density	dBW/m ²	-123,1	-126,1	-127,8	-122,1	-125,3	-127,0	-122,1	-125,3	-127,0	-122,2	-125,4	-127,1
Total Received PFD	dBW/m ² /1 MHz	-99,9	-103,1	-104,9	-98,8	-102,1	-103,9	-98,8	-102,1	-103,9	-98,9	-102,2	-103,9
PFD max. @ UE Elev. Angle (ITU Rec.)	dBW/m ² /1 MHz	-118,0	-118,0	-122,5	-118,0	-118,0	-122,5	-118,0	-118,0	-122,5	-118,0	-118,0	-122,5
DL Single Finger C/(No+Io)	dBHz	41,6	41,6	41,6	41,6	41,6	41,6	41,6	41,6	41,6	41,6	41,6	41,6
DL Single Finger Eb/(No+Io)	dB	10,8	10,8	10,8	10,8	10,9	10,8	10,9	10,9	10,8	10,9	10,8	10,9
Eb/No Losses due to Satellite Non-Linearities	dB	1,5	1,5	1,5	1,5	1,5	1,5	1,5	1,5	1,5	1,5	1,5	1,5
Eb/No Losses due to feeder link degradation (see TR30.20)	dB	0,2	0,2	0,2	0,2	0,2	0,2	0,2	0,2	0,2	0,2	0,2	0,2
Overall Link Single Finger Eb/(No+Io)	dB	9,1	9,1	9,1	9,1	9,2	9,1	9,2	9,2	9,1	9,2	9,1	9,2
Total C/(N+I)	dB	-26,8	-26,8	-26,8	-26,8	-26,8	-26,8	-26,8	-26,8	-26,8	-26,8	-26,8	-26,8
Margin for Bent-Pipe System	dB	0,0	0,0	0,0	0,0	0,0	0,0	0,0	0,0	0,0	0,0	0,0	0,0
Capacity/spot/FDM	Mb/s	0,8652	0,8316	0,798	0,8808	0,8616	0,8424	0,882	0,8652	0,8472	0,888	0,8784	0,8652
Nb. Traffic Codes/FDM/Beam	-	721	693	665	734	718	702	735	721	706	740	732	721
Nb of codes on primary scrambling code	-	510	510	510	510	510	510	510	510	510	510	510	510
Nb of codes on secondary scrambling codes	-	211	183	155	224	208	192	225	211	196	230	222	211
Nb of Secondary Scrambling Codes/FDM/Beam	-	1	1	1	1	1	1	1	1	1	1	1	1
Satellite capacity (30 spots)	Mb/s	25,96	24,95	23,94	26,42	25,85	25,27	26,46	25,96	25,42	26,64	26,35	25,96
Spectrum efficiency as ITU	bit/s/Hz	0,185	0,178	0,170	0,188	0,184	0,180	0,188	0,185	0,181	0,190	0,188	0,185
Power efficiency as ITU		12,18%	12,17%	12,17%	12,18%	12,15%	12,18%	12,16%	12,16%	12,17%	12,16%	12,19%	12,15%

C.1.2 Speech service 4,75 kbps

Table C.4: Downlink budget; Speech 4,75 kbps

FORWARD LINK BUDGET		Handset 0 dBi			Portable			Vehicular			Transportable		
UE elevation	deg.	42	30	16	42	30	16	42	30	16	42	30	16
Data Rate	bit/s	4 750	4 750	4 750	4 750	4 750	4 750	4 750	4 750	4 750	4 750	4 750	4 750
Traffic Activity Factor		0,5	0,5	0,5	0,5	0,5	0,5	0,5	0,5	0,5	0,5	0,5	0,5
Required Eb/(No+Io) per Finger	dB	9,08	9,08	9,08	9,08	9,08	9,08	9,08	9,08	9,08	9,08	9,08	9,08
On Board Power/FACH/Beam/FDM	dBW	-4,01	-3,76	-3,48	-4,12	-4,01	-3,91	-4,16	-4,02	-3,90	-4,21	-4,16	-4,11
On Board EIRP/FACH/Beam/FDM	dBW	42,99	40,24	39,02	42,88	39,99	38,59	42,84	39,98	38,60	42,79	39,84	38,39
CPICH EIRP / Beam / FDM	dBW	51,99	49,24	48,02	51,88	48,99	47,59	51,84	48,98	47,60	51,79	48,84	47,39
P-CCPCH EIRP / Beam / FDM	dBW	49,99	47,24	46,02	49,88	46,99	45,59	49,84	46,98	45,60	49,79	46,84	45,39
SCH EIRP / Beam / FDM	dBW	49,99	47,24	46,02	49,88	46,99	45,59	49,84	46,98	45,60	49,79	46,84	45,39
PICH EIRP / Beam / FDM	dBW	46,99	44,24	43,02	46,88	43,99	42,59	46,84	43,98	42,60	46,79	43,84	42,39
Common Physical Channels Equivalent Traffic Codes	-	20,48	20,48	20,48	20,48	20,48	20,48	20,48	20,48	20,48	20,48	20,48	20,48
On Board Power / Beam / FDM	dB	23,0	23,0	23,0	23,0	23,0	23,0	23,0	23,0	23,0	23,0	23,0	23,0
On Board power Density	dB/Hz	-43,7	-43,7	-43,7	-43,7	-43,7	-43,7	-43,7	-43,7	-43,7	-43,7	-43,7	-43,7
On board EIRP / Beam / FDM	dBW	70,0	67,0	65,5	70,0	67,0	65,5	70,0	67,0	65,5	70,0	67,0	65,5
On Board Power / Beam	W	198,8	198,4	199,9	200,0	199,6	198,1	198,9	199,9	200,0	199,3	199,3	198,9
Saturated Power / Beam	W	268,1	267,6	269,6	269,8	269,2	267,3	268,3	269,7	269,8	268,9	268,9	268,3
Saturated On Board EIRP / Beam	dBW	71,3	68,3	66,8	71,3	68,3	66,8	71,3	68,3	66,8	71,3	68,3	66,8
Losses (free space, polarization, pointing and body)	dB	192,2	192,5	192,8	191,2	191,5	191,8	191,2	191,5	191,8	191,2	191,5	191,8
UE Antenna Gain	dB	0	0	0	2	2	2	4	4	4	14	14	14
UE G/T	dB/K	-24,6	-24,6	-24,6	-21,0	-21,0	-21,0	-20,0	-20,0	-20,0	-9,0	-9,0	-9,0
Thermal Noise Density, No	dBW/Hz	-204,0	-204,0	-204,0	-205,6	-205,6	-205,6	-204,6	-204,6	-204,6	-205,6	-205,6	-205,6
Interference from secondary scrambling codes	dBW	-128,7	-132,3	-134,4	-125,5	-128,9	-130,9	-123,5	-126,9	-128,8	-113,5	-116,7	-118,6
Interference from adjacent spot	dBW	-139,1	-141,3	-142,1	-136,1	-138,3	-139,1	-134,1	-136,3	-137,1	-124,1	-126,3	-127,1
Total interference per channel	dBW	-128,3	-131,8	-133,7	-125,2	-128,4	-130,3	-123,2	-126,4	-128,2	-113,1	-116,3	-118,0
-10*LOG(Spreading Bandwidth)	dB/Hz	-65,8	-65,8	-65,8	-65,8	-65,8	-65,8	-65,8	-65,8	-65,8	-65,8	-65,8	-65,8
Interference Density, Io	dBW/Hz	-194,2	-197,6	-199,6	-191,0	-194,3	-196,1	-189,0	-192,3	-194,1	-178,9	-182,1	-183,9
10*log(No+Io)	dBW/Hz	-193,7	-196,7	-198,2	-190,9	-194,0	-195,7	-188,9	-192,0	-193,7	-178,9	-182,1	-183,9
Rx Power Flux Density	dBW/m ²	-121,0	-124,0	-125,5	-120,1	-123,2	-124,9	-120,2	-123,2	-124,9	-120,2	-123,4	-125,1
Total Received PFD	dBW/m ² /1 MHz	-99,9	-103,1	-104,9	-98,8	-102,1	-103,9	-98,9	-102,1	-103,9	-98,9	-102,1	-103,9
PFD max. @ UE Elev. Angle (ITU Rec.)	dBW/m ² /1 MHz	-118,0	-118,0	-122,5	-118,0	-118,0	-122,5	-118,0	-118,0	-122,5	-118,0	-118,0	-122,5
DL Single Finger C/(No+Io)	dBHz	47,5	47,5	47,5	47,5	47,5	47,5	47,5	47,5	47,5	47,5	47,5	47,5
DL Single Finger Eb/(No+Io)	dB	10,7	10,7	10,7	10,7	10,7	10,7	10,7	10,8	10,8	10,7	10,7	10,7
Eb/No Losses due to Satellite Non-Linearities	dB	1,5	1,5	1,5	1,5	1,5	1,5	1,5	1,5	1,5	1,5	1,5	1,5
Eb/No Losses due to feeder link degradation (see TR30.20)	dB	0,2	0,2	0,2	0,2	0,2	0,2	0,2	0,2	0,2	0,2	0,2	0,2
Overall Link Single Finger Eb/(No+Io)	dB	9,0	9,0	9,0	9,0	9,0	9,0	9,0	9,1	9,1	9,0	9,0	9,0
Total C/(N+I)	dB	-20,9	-20,9	-20,9	-20,9	-20,9	-20,9	-20,9	-20,9	-20,9	-20,9	-20,9	-20,9
Margin for Bent-Pipe System	dB	0,0	0,0	0,0	0,0	0,0	0,0	0,0	0,0	0,0	0,0	0,0	0,0
Capacity/spot/FDM	Mb/s	1,14	1,0711	1,0094	1,178	1,1448	1,1091	1,1828	1,1495	1,1163	1,1994	1,1851	1,1685
Nb. Traffic Codes/FDM/Beam	-	480	451	425	496	482	467	498	484	470	505	499	492
Nb of codes on primary scrambling code	-	254	254	254	254	254	254	254	254	254	254	254	254
Nb of codes on secondary scrambling codes	-	226	197	171	242	228	213	244	230	216	251	245	238
Nb of Secondary Scrambling Codes/FDM/Beam	-	1	1	1	1	1	1	1	1	1	1	1	1
Satellite capacity (30 spots)	Mb/s	34,20	32,13	30,28	35,34	34,34	33,27	35,48	34,49	33,49	35,98	35,55	35,06
Spectrum efficiency as ITU	bit/s/Hz	0,243	0,229	0,215	0,251	0,244	0,237	0,252	0,245	0,238	0,256	0,253	0,249
Power efficiency as ITU		12,47%	12,49%	12,50%	12,47%	12,49%	12,48%	12,48%	12,40%	12,35%	12,50%	12,50%	12,51%

C.1.3 Speech service 12,2 kbps

Table C.5: Downlink budget; Speech 12,2 kbps

FORWARD LINK BUDGET		Handset 0 dBi			Portable			Vehicular			Transportable		
UE elevation	deg.	42	30	16	42	30	16	42	30	16	42	30	16
Data Rate	bit/s	12 200	12 200	12 200	12 200	12 200	12 200	12 200	12 200	12 200	12 200	12 200	12 200
Traffic Activity Factor		0,5	0,5	0,5	0,5	0,5	0,5	0,5	0,5	0,5	0,5	0,5	0,5
Required Eb/(No+Io) per Finger	dB	7,38	7,38	7,38	7,38	7,38	7,38	7,38	7,38	7,38	7,38	7,38	7,38
On Board Power/FACH/Beam/FDM	dBW	-1,31	-1,01	-0,81	-1,41	-1,25	-1,11	-1,45	-1,36	-1,21	-1,51	-1,51	-1,41
On Board EIRP/FACH/Beam/FDM	dBW	45,69	42,99	41,69	45,59	42,75	41,39	45,55	42,64	41,29	45,49	42,49	41,09
CPICH EIRP / Beam / FDM	dBW	52,29	49,59	48,29	52,19	49,35	47,99	52,15	49,24	47,89	52,09	49,09	47,69
P-CCPCH EIRP / Beam / FDM	dBW	50,29	47,59	46,29	50,19	47,35	45,99	50,15	47,24	45,89	50,09	47,09	45,69
SCH EIRP / Beam / FDM	dBW	50,29	47,59	46,29	50,19	47,35	45,99	50,15	47,24	45,89	50,09	47,09	45,69
PICH EIRP / Beam / FDM	dBW	47,29	44,59	43,29	47,19	44,35	42,99	47,15	44,24	42,89	47,09	44,09	42,69
Common Physical Channels Equivalent Traffic Codes	-	11,78	11,78	11,78	11,78	11,78	11,78	11,78	11,78	11,78	11,78	11,78	11,78
On Board Power / Beam / FDM	dB	23,0	23,0	23,0	23,0	23,0	23,0	23,0	23,0	23,0	23,0	22,9	23,0
On Board power Density	dB/Hz	-43,7	-43,7	-43,7	-43,7	-43,7	-43,7	-43,7	-43,7	-43,7	-43,7	-43,8	-43,7
On board EIRP / Beam / FDM	dBW	70,0	67,0	65,5	70,0	67,0	65,5	70,0	67,0	65,5	70,0	66,9	65,5
On Board Power / Beam	W	199,5	199,5	199,0	199,3	200,0	198,9	199,6	198,0	199,6	199,7	196,9	198,6
Saturated Power / Beam	W	269,1	269,2	268,4	268,9	269,9	268,2	269,3	267,1	269,3	269,4	265,6	267,9
Saturated On Board EIRP / Beam	dBW	71,3	68,3	66,8	71,3	68,3	66,8	71,3	68,3	66,8	71,3	68,2	66,8
Losses (free space, polarization, pointing and body)	dB	192,2	192,5	192,8	191,2	191,5	191,8	191,2	191,5	191,8	191,2	191,5	191,8
UE Antenna Gain	dB	0	0	0	2	2	2	4	4	4	14	14	14
UE G/T	dB/K	-24,6	-24,6	-24,6	-22,6	-22,6	-22,6	-20,6	-20,6	-20,6	-10,6	-10,6	-10,6
Thermal Noise Density, No	dBW/Hz	-204,0	-204,0	-204,0	-204,0	-204,0	-204,0	-204,0	-204,0	-204,0	-204,0	-204,0	-204,0
Interference from secondary scrambling codes	dBW	-128,4	-131,9	-134,0	-125,3	-128,6	-130,6	-123,2	-126,6	-128,5	-113,1	-116,5	-118,3
Interference from adjacent spot	dBW	-139,1	-141,3	-142,1	-136,1	-138,3	-139,1	-134,1	-136,3	-137,1	-124,1	-126,4	-127,1
Total interference per channel	dBW	-128,0	-131,4	-133,4	-124,9	-128,2	-130,0	-122,9	-126,2	-127,9	-112,8	-116,1	-117,8
-10*LOG(Spreading Bandwidth)	dB/Hz	-65,8	-65,8	-65,8	-65,8	-65,8	-65,8	-65,8	-65,8	-65,8	-65,8	-65,8	-65,8
Interference Density, Io	dBW/Hz	-193,8	-197,3	-199,2	-190,8	-194,0	-195,9	-188,7	-192,0	-193,8	-178,7	-181,9	-183,6
10*log(No+Io)	dBW/Hz	-193,4	-196,4	-198,0	-190,6	-193,6	-195,3	-188,6	-191,7	-193,4	-178,6	-181,9	-183,6
Rx Power Flux Density	dBW/m ²	-118,3	-121,2	-122,8	-117,4	-120,5	-122,1	-117,5	-120,6	-122,2	-117,5	-120,7	-122,4
Total Received PFD	dBW/m ² /1 MHz	-99,8	-103,1	-104,9	-98,9	-102,1	-103,9	-98,8	-102,1	-103,9	-98,8	-102,1	-103,9
PFD max. @ UE Elev. Angle (ITU Rec.)	dBW/m ² /1 MHz	-118,0	-118,0	-122,5	-118,0	-118,0	-122,5	-118,0	-118,0	-122,5	-118,0	-118,0	-122,5
DL Single Finger C/(No+Io)	dBHz	49,9	50,0	49,9	49,9	49,9	49,9	49,9	49,9	49,9	49,9	49,9	49,9
DL Single Finger Eb/(No+Io)	dB	9,0	9,1	9,0	9,1	9,0	9,0	9,0	9,1	9,0	9,0	9,1	9,1
Eb/No Losses due to Satellite Non-Linearities	dB	1,5	1,5	1,5	1,5	1,5	1,5	1,5	1,5	1,5	1,5	1,5	1,5
Eb/No Losses due to feeder link degradation (see TR30.20)	dB	0,2	0,2	0,2	0,2	0,2	0,2	0,2	0,2	0,2	0,2	0,2	0,2
Overall Link Single Finger Eb/(No+Io)	dB	7,3	7,4	7,3	7,4	7,3	7,3	7,3	7,4	7,3	7,3	7,4	7,4
Total C/(N+I)	dB	-18,5	-18,4	-18,5	-18,5	-18,5	-18,5	-18,5	-18,5	-18,5	-18,5	-18,5	-18,5
Margin for Bent-Pipe System	dB	0,0	0,0	0,0	0,0	0,0	0,0	0,0	0,0	0,0	0,0	0,0	0,0
Capacity/spot/FDM	Mb/s	1,5738	1,464	1,3908	1,6104	1,5555	1,4945	1,6287	1,5799	1,5372	1,6531	1,6287	1,6043
Nb. Traffic Codes/FDM/Beam	-	258	240	228	264	255	245	267	259	252	271	267	263
Nb of codes on primary scrambling code	-	126	126	126	126	126	126	126	126	126	126	126	126
Nb of codes on secondary scrambling codes	-	132	114	102	138	129	119	141	133	126	145	141	137
Nb of Secondary Scrambling Codes/FDM/Beam	-	2	1	1	2	2	1	2	2	1	2	2	2
Satellite capacity (30 spots)	Mb/s	47,21	43,92	41,72	48,31	46,67	44,84	48,86	47,40	46,12	49,59	48,86	48,13
Spectrum efficiency as ITU	bit/s/Hz	0,336	0,313	0,297	0,344	0,332	0,319	0,348	0,337	0,328	0,353	0,348	0,342
Power efficiency as ITU		18,46%	18,15%	18,47%	18,39%	18,49%	18,45%	18,46%	18,39%	18,45%	18,47%	18,39%	18,39%

C.1.4 Data service 64 kbps

Table C.6: Downlink budget; Data 64 kbps

FORWARD LINK BUDGET		Handset 0 dBi			Portable			Vehicular			Transportable		
UE elevation	deg.	42	30	16	42	30	16	42	30	16	42	30	16
Data Rate	bit/s	64 000	64 000	64 000	64 000	64 000	64 000	64 000	64 000	64 000	64 000	64 000	64 000
Traffic Activity Factor		1,0	1,0	1,0	1,0	1,0	1,0	1,0	1,0	1,0	1,0	1,0	1,0
Required Eb/(No+Io) per Finger	dB	3,98	3,98	3,98	3,98	3,98	3,98	3,98	3,98	3,98	3,98	3,98	3,98
On Board Power/FACH/Beam/FDM	dBW	6,00	6,00	5,80	3,00	5,00	5,50	6,00	6,00	6,00	-1,00	-3,00	6,00
On Board EIRP/FACH/Beam/FDM	dBW	53,00	50,00	48,30	50,00	49,00	48,00	53,00	50,00	48,50	46,00	41,00	48,50
CPICH EIRP / Beam / FDM	dBW	55,80	52,80	51,10	52,80	51,80	50,80	55,80	52,80	51,30	48,80	43,80	51,30
P-CCPCH EIRP / Beam / FDM	dBW	53,80	50,80	49,10	50,80	49,80	48,80	53,80	50,80	49,30	46,80	41,80	49,30
SCH EIRP / Beam / FDM	dBW	53,80	50,80	49,10	50,80	49,80	48,80	53,80	50,80	49,30	46,80	41,80	49,30
PICH EIRP / Beam / FDM	dBW	50,80	47,80	46,10	47,80	46,80	45,80	50,80	47,80	46,30	43,80	38,80	46,30
Common Physical Channels Equivalent Traffic Codes	-	4,91	4,91	4,91	4,91	4,91	4,91	4,91	4,91	4,91	4,91	4,91	4,91
On Board Power / Beam / FDM	dB	22,9	22,7	22,3	19,9	21,8	22,2	23,0	22,9	22,8	16,0	13,9	22,9
On Board power Density	dB/Hz	-43,8	-44,0	-44,4	-46,8	-44,9	-44,5	-43,7	-43,8	-43,9	-50,7	-52,8	-43,8
On board EIRP / Beam / FDM	dBW	69,9	66,7	64,8	66,9	65,8	64,7	70,0	66,9	65,3	63,0	57,9	65,4
On Board Power / Beam	W	194,7	186,8	170,8	97,6	151,5	166,5	198,7	194,7	190,7	39,6	24,5	194,7
Saturated Power / Beam	W	262,7	251,9	230,3	131,6	204,4	224,5	268,0	262,7	257,3	53,5	33,1	262,7
Saturated On Board EIRP / Beam	dBW	71,2	68,0	66,1	68,2	67,1	66,0	71,3	68,2	66,6	64,3	59,2	66,7
Losses (free space, polarization, pointing and body)	dB	192,2	192,5	192,8	191,2	191,5	191,8	191,2	191,5	191,8	191,2	191,5	191,8
UE Antenna Gain	dB	0	0	0	2	2	2	4	4	4	14	14	14
UE G/T	dB/K	-24,6	-24,6	-24,6	-22,6	-22,6	-22,6	-20,6	-20,6	-20,6	-10,6	-10,6	-10,6
Thermal Noise Density, No	dBW/Hz	-204,0	-204,0	-204,0	-204,0	-204,0	-204,0	-204,0	-204,0	-204,0	-204,0	-204,0	-204,0
Interference from secondary scrambling codes	dBW	-128,1	-132,1	-134,9	-128,1	-129,7	-131,3	-122,8	-126,3	-128,5	-119,8	-125,3	-118,1
Interference from adjacent spot	dBW	-136,3	-138,8	-139,9	-136,3	-136,7	-137,0	-131,3	-133,6	-134,5	-128,3	-132,6	-124,4
Total interference per channel	dBW	-127,5	-131,2	-133,7	-127,5	-128,9	-130,3	-122,2	-125,6	-127,5	-119,2	-124,6	-117,2
-10*LOG(Spreading Bandwidth)	dB/Hz	-65,8	-65,8	-65,8	-65,8	-65,8	-65,8	-65,8	-65,8	-65,8	-65,8	-65,8	-65,8
Interference Density, Io	dBW/Hz	-193,3	-197,1	-199,6	-193,3	-194,7	-196,2	-188,0	-191,4	-193,3	-185,0	-190,4	-183,0
10*log(No+Io)	dBW/Hz	-193,0	-196,3	-198,2	-193,0	-194,2	-195,5	-187,9	-191,2	-193,0	-185,0	-190,2	-183,0
Rx Power Flux Density	dBW/m ²	-111,0	-114,2	-116,2	-113,0	-114,2	-115,5	-110,0	-113,2	-115,0	-117,0	-122,2	-115,0
Total Received PFD	dBW/m ² /1 MHz	-100,0	-103,4	-105,5	-102,0	-103,3	-104,7	-98,9	-102,2	-104,1	-105,9	-111,2	-104,0
PFD max. @ UE Elev. Angle (ITU Rec.)	dBW/m ² /1 MHz	-118,0	-118,0	-122,5	-118,0	-118,0	-122,5	-118,0	-118,0	-122,5	-118,0	-118,0	-122,5
DL Single Finger C/(No+Io)	dBHz	53,7	53,8	53,8	53,7	53,8	53,7	53,7	53,7	53,7	53,8	53,8	53,7
DL Single Finger Eb/(No+Io)	dB	5,7	5,7	5,7	5,7	5,7	5,7	5,6	5,7	5,7	5,7	5,7	5,7
Eb/No Losses due to Satellite Non-Linearities	dB	1,5	1,5	1,5	1,5	1,5	1,5	1,5	1,5	1,5	1,5	1,5	1,5
Eb/No Losses due to feeder link degradation (see TR30.20)	dB	0,2	0,2	0,2	0,2	0,2	0,2	0,2	0,2	0,2	0,2	0,2	0,2
Overall Link Single Finger Eb/(No+Io)	dB	4,0	4,0	4,0	4,0	4,0	4,0	3,9	4,0	4,0	4,0	4,0	4,0
Total C/(N+I)	dB	-14,7	-14,6	-14,6	-14,7	-14,6	-14,7	-14,7	-14,7	-14,7	-14,7	-14,6	-14,7
Margin for Bent-Pipe System	dB	0,0	0,0	0,0	0,0	0,0	0,0	0,0	0,0	0,0	0,0	0,0	0,0
Capacity/spot/FDM	Mb/s	2,816	2,688	2,56	2,816	2,752	2,688	2,88	2,816	2,752	2,88	2,816	2,816
Nb. Traffic Codes/FDM/Beam	-	44	42	40	44	43	42	45	44	43	45	44	44
Nb of codes on primary scrambling code	-	31	31	31	31	31	31	31	31	31	31	31	31
Nb of codes on secondary scrambling codes	-	13	11	9	13	12	11	14	13	12	14	13	13
Nb of Secondary Scrambling Codes/FDM/Beam	-	1	1	1	1	1	1	1	1	1	1	1	1
Satellite capacity (30 spots)	Mb/s	84,48	80,64	76,80	84,48	82,56	80,64	86,40	84,48	82,56	86,40	84,48	84,48
Spectrum efficiency as ITU	bit/s/Hz	0,601	0,574	0,546	0,601	0,587	0,574	0,615	0,601	0,587	0,615	0,601	0,601
Power efficiency as ITU		40,03%	39,60%	39,76%	40,03%	39,72%	40,10%	40,42%	40,20%	40,23%	39,92%	39,77%	39,98%

C.1.5 Data service 144 kbps

Table C.7: Downlink budget; Data 144 kbps

FORWARD LINK BUDGET		Handset 0 dBi			Portable			Vehicular			Transportable		
UE elevation	deg.	42	30	16	42	30	16	42	30	16	42	30	16
Data Rate	bit/s	144 000	144 000	144 000	144 000	144 000	144 000	144 000	144 000	144 000	144 000	144 000	144 000
Traffic Activity Factor		1,0	1,0	1,0	1,0	1,0	1,0	1,0	1,0	1,0	1,0	1,0	1,0
Required Eb/(No+Io) per Finger	dB	3,46	3,46	3,46	3,46	3,46	3,46	3,46	3,46	3,46	3,46	3,46	3,46
On Board Power/FACH/Beam/FDM	dBW	6,50	7,50	7,70	3,50	7,50	7,00	9,00	5,50	9,00	4,00	-4,50	-1,00
On Board EIRP/FACH/Beam/FDM	dBW	53,50	51,50	50,20	50,50	51,50	49,50	56,00	49,50	51,50	51,00	39,50	41,50
CPICH EIRP / Beam / FDM	dBW	53,30	51,30	50,00	50,30	51,30	49,30	55,80	49,30	51,30	50,80	39,30	41,30
P-CCPCH EIRP / Beam / FDM	dBW	51,30	49,30	48,00	48,30	49,30	47,30	53,80	47,30	49,30	48,80	37,30	39,30
SCH EIRP / Beam / FDM	dBW	51,30	49,30	48,00	48,30	49,30	47,30	53,80	47,30	49,30	48,80	37,30	39,30
PICH EIRP / Beam / FDM	dBW	48,30	46,30	45,00	45,30	46,30	44,30	50,80	44,30	46,30	45,80	34,30	36,30
Common Physical Channels Equivalent Traffic Codes	-	2,46	2,46	2,46	2,46	2,46	2,46	2,46	2,46	2,46	2,46	2,46	2,46
On Board Power / Beam / FDM	dB	20,2	21,0	21,0	17,2	21,2	20,5	22,9	19,2	22,7	17,9	9,2	12,7
On Board power Density	dB/Hz	-46,5	-45,7	-45,7	-49,5	-45,5	-46,2	-43,8	-47,5	-44,0	-48,8	-57,5	-54,0
On board EIRP / Beam / FDM	dBW	67,2	65,0	63,5	64,2	65,2	63,0	69,9	63,2	65,2	64,9	53,2	55,2
On Board Power / Beam	W	104,8	126,3	126,4	52,5	131,9	112,6	194,3	83,2	186,4	61,4	8,3	18,6
Saturated Power / Beam	W	141,4	170,4	170,5	70,9	178,0	151,9	262,1	112,3	251,4	82,9	11,2	25,1
Saturated On Board EIRP / Beam	dBW	68,5	66,3	64,8	65,5	66,5	64,3	71,2	64,5	66,5	66,2	54,5	56,5
Losses (free space, polarization, pointing and body)	dB	192,2	192,5	192,8	191,2	191,5	191,8	191,2	191,5	191,8	191,2	191,5	191,8
UE Antenna Gain	dB	0	0	0	2	2	2	4	4	4	14	14	14
UE G/T	dB/K	-24,6	-24,6	-24,6	-22,6	-22,6	-22,6	-20,6	-20,6	-20,6	-10,6	-10,6	-10,6
Thermal Noise Density, No	dBW/Hz	-204,0	-204,0	-204,0	-204,0	-204,0	-204,0	-204,0	-204,0	-204,0	-204,0	-204,0	-204,0
Interference from secondary scrambling codes	dBW	-131,0	-134,0	-136,5	-131,0	-130,2	-133,3	-122,8	-130,2	-128,5	-117,8	-130,2	-128,5
Interference from adjacent spot	dBW	-139,0	-140,5	-141,2	-139,0	-137,3	-138,7	-131,4	-137,3	-134,6	-126,4	-137,3	-134,6
Total interference per channel	dBW	-130,3	-133,1	-135,3	-130,3	-129,4	-132,2	-122,2	-129,4	-127,5	-117,2	-129,4	-127,5
-10*LOG(Spreading Bandwidth)	dB/Hz	-65,8	-65,8	-65,8	-65,8	-65,8	-65,8	-65,8	-65,8	-65,8	-65,8	-65,8	-65,8
Interference Density, Io	dBW/Hz	-196,2	-198,9	-201,1	-196,2	-195,2	-198,0	-188,1	-195,2	-193,4	-183,1	-195,2	-193,4
10*log(No+Io)	dBW/Hz	-195,5	-197,8	-199,3	-195,5	-194,7	-197,0	-188,0	-194,7	-193,0	-183,0	-194,7	-193,0
Rx Power Flux Density	dBW/m ²	-110,5	-112,7	-114,3	-112,5	-111,7	-114,0	-107,0	-113,7	-112,0	-112,0	-123,7	-122,0
Total Received PFD	dBW/m ² /1 MHz	-102,6	-105,1	-106,9	-104,6	-103,9	-106,4	-99,0	-105,9	-104,2	-104,0	-115,9	-114,2
PFD max. @ UE Elev. Angle (ITU Rec.)	dBW/m ² /1 MHz	-118,0	-118,0	-122,5	-118,0	-118,0	-122,5	-118,0	-118,0	-122,5	-118,0	-118,0	-122,5
DL Single Finger C/(No+Io)	dBHz	56,8	56,8	56,7	56,8	56,7	56,8	56,7	56,7	56,7	56,8	56,7	56,7
DL Single Finger Eb/(No+Io)	dB	5,2	5,2	5,2	5,2	5,2	5,2	5,1	5,2	5,2	5,2	5,2	5,2
Eb/No Losses due to Satellite Non-Linearities	dB	1,5	1,5	1,5	1,5	1,5	1,5	1,5	1,5	1,5	1,5	1,5	1,5
Eb/No Losses due to feeder link degradation (see TR30.20)	dB	0,2	0,2	0,2	0,2	0,2	0,2	0,2	0,2	0,2	0,2	0,2	0,2
Overall Link Single Finger Eb/(No+Io)	dB	3,5	3,5	3,5	3,5	3,5	3,5	3,4	3,5	3,5	3,5	3,5	3,5
Total C/(N+I)	dB	-11,6	-11,6	-11,7	-11,6	-11,7	-11,6	-11,7	-11,7	-11,7	-11,6	-11,7	-11,7
Margin for Bent-Pipe System	dB	0,0	0,0	0,0	0,0	0,0	0,0	0,0	0,0	0,0	0,0	0,0	0,0
Capacity/spot/FDM	Mb/s	3,024	2,88	2,736	3,024	3,024	2,88	3,168	3,024	3,024	3,168	3,024	3,024
Nb. Traffic Codes/FDM/Beam	-	21	20	19	21	21	20	22	21	21	22	21	21
Nb of codes on primary scrambling code	-	15	15	15	15	15	15	15	15	15	15	15	15
Nb of codes on secondary scrambling codes	-	6	5	4	6	6	5	7	6	6	7	6	6
Nb of Secondary Scrambling Codes/FDM/Beam	-	1	1	1	1	1	1	1	1	1	1	1	1
Satellite capacity (30 spots)	Mb/s	90,72	86,40	82,08	90,72	90,72	86,40	95,04	90,72	90,72	95,04	90,72	90,72
Spectrum efficiency as ITU	bit/s/Hz	0,645	0,615	0,584	0,645	0,645	0,615	0,676	0,645	0,645	0,676	0,645	0,645
Power efficiency as ITU		44,84%	44,63%	45,08%	44,84%	45,14%	44,65%	45,36%	45,14%	45,10%	44,59%	45,14%	45,10%

C.1.6 Data service 384 kbps

Table C.8: Downlink budget; Data 384 kbps

FORWARD LINK BUDGET		Handset 0 dBi			Portable			Vehicular			Transportable		
UE elevation	deg.	42	30	16	42	30	16	42	30	16	42	30	16
Data Rate	bit/s	384 000	384 000	384 000	384 000	384 000	384 000	384 000	384 000	384 000	384 000	384 000	384 000
Traffic Activity Factor		1,0	1,0	1,0	1,0	1,0	1,0	1,0	1,0	1,0	1,0	1,0	1,0
Required Eb/(No+Io) per Finger	dB	3,50	3,50	3,50	3,50	3,50	3,50	3,50	3,50	3,50	3,50	3,50	3,50
On Board Power/FACH/Beam/FDM	dBW	9,00	13,00	10,50	6,00	10,00	13,00	4,00	8,00	11,00	-6,00	-2,00	1,00
On Board EIRP/FACH/Beam/FDM	dBW	56,00	57,00	53,00	53,00	54,00	55,50	51,00	52,00	53,50	41,00	42,00	43,50
CPICH EIRP / Beam / FDM	dBW	51,50	52,50	48,50	48,50	49,50	51,00	46,50	47,50	49,00	36,50	37,50	39,00
P-CCPCH EIRP / Beam / FDM	dBW	49,50	50,50	46,50	46,50	47,50	49,00	44,50	45,50	47,00	34,50	35,50	37,00
SCH EIRP / Beam / FDM	dBW	49,50	50,50	46,50	46,50	47,50	49,00	44,50	45,50	47,00	34,50	35,50	37,00
PICH EIRP / Beam / FDM	dBW	46,50	47,50	43,50	43,50	44,50	46,00	41,50	42,50	44,00	31,50	32,50	34,00
Common Physical Channels Equivalent Traffic Codes	-	0,91	0,91	0,91	0,91	0,91	0,91	0,91	0,91	0,91	0,91	0,91	0,91
On Board Power / Beam / FDM	dB	19,0	23,0	20,0	16,0	20,0	23,0	14,0	18,0	21,0	4,0	8,0	11,0
On Board power Density	dB/Hz	-47,7	-43,7	-46,7	-50,7	-46,7	-43,7	-52,7	-48,7	-45,7	-62,7	-58,7	-55,7
On board EIRP / Beam / FDM	dBW	66,0	67,0	62,5	63,0	64,0	65,5	61,0	62,0	63,5	51,0	52,0	53,5
On Board Power / Beam	W	78,8	197,8	100,0	39,5	99,1	197,8	24,9	62,6	124,8	2,5	6,3	12,5
Saturated Power / Beam	W	106,2	266,9	134,9	53,2	133,7	266,9	33,6	84,4	168,4	3,4	8,4	16,8
Saturated On Board EIRP / Beam	dBW	67,3	68,3	63,8	64,3	65,3	66,8	62,3	63,3	64,8	52,3	53,3	54,8
Losses (free space, polarization, pointing and body)	dB	192,2	192,5	192,8	191,2	191,5	191,8	191,2	191,5	191,8	191,2	191,5	191,8
UE Antenna Gain	dB	0	0	0	2	2	2	4	4	4	14	14	14
UE G/T	dB/K	-24,6	-24,6	-24,6	-22,6	-22,6	-22,6	-20,6	-20,6	-20,6	-10,6	-10,6	-10,6
Thermal Noise Density, No	dBW/Hz	-204,0	-204,0	-204,0	-204,0	-204,0	-204,0	-204,0	-204,0	-204,0	-204,0	-204,0	-204,0
Interference from secondary scrambling codes	dBW	-133,2	-132,5	-139,8	-133,2	-132,5	-131,3	-133,2	-132,5	-131,3	-133,2	-132,5	-131,3
Interference from adjacent spot	dBW	-140,3	-138,5	-142,3	-140,3	-138,5	-136,3	-140,3	-138,5	-136,3	-140,3	-138,5	-136,3
Total interference per channel	dBW	-132,4	-131,5	-137,8	-132,4	-131,5	-130,1	-132,4	-131,5	-130,1	-132,4	-131,5	-130,1
-10*LOG(Spreading Bandwidth)	dB/Hz	-65,8	-65,8	-65,8	-65,8	-65,8	-65,8	-65,8	-65,8	-65,8	-65,8	-65,8	-65,8
Interference Density, Io	dBW/Hz	-198,3	-197,3	-203,7	-198,3	-197,3	-195,9	-198,3	-197,3	-195,9	-198,3	-197,3	-195,9
10*log(No+Io)	dBW/Hz	-197,3	-196,5	-200,8	-197,3	-196,5	-195,3	-197,3	-196,5	-195,3	-197,3	-196,5	-195,3
Rx Power Flux Density	dBW/m ²	-108,0	-107,2	-111,5	-110,0	-109,2	-108,0	-112,0	-111,2	-110,0	-122,0	-121,2	-120,0
Total Received PFD	dBW/m ² /1 MHz	-103,9	-103,1	-107,9	-105,9	-105,1	-103,9	-107,9	-107,1	-105,9	-117,9	-117,1	-115,9
PFD max. @ UE Elev. Angle (ITU Rec.)	dBW/m ² /1 MHz	-118,0	-118,0	-122,5	-118,0	-118,0	-122,5	-118,0	-118,0	-122,5	-118,0	-118,0	-122,5
DL Single Finger C/(No+Io)	dBHz	61,0	61,0	61,0	61,0	61,0	61,0	61,0	61,0	61,0	61,0	61,0	61,0
DL Single Finger Eb/(No+Io)	dB	5,2	5,2	5,2	5,2	5,2	5,2	5,2	5,2	5,2	5,2	5,2	5,2
Eb/No Losses due to Satellite Non-Linearities	dB	1,5	1,5	1,5	1,5	1,5	1,5	1,5	1,5	1,5	1,5	1,5	1,5
Eb/No Losses due to feeder link degradation (see TR30.20)	dB	0,2	0,2	0,2	0,2	0,2	0,2	0,2	0,2	0,2	0,2	0,2	0,2
Overall Link Single Finger Eb/(No+Io)	dB	3,5	3,5	3,5	3,5	3,5	3,5	3,5	3,5	3,5	3,5	3,5	3,5
Total C/(N+I)	dB	-7,4	-7,4	-7,4	-7,4	-7,4	-7,4	-7,4	-7,4	-7,4	-7,4	-7,4	-7,4
Margin for Bent-Pipe System	dB	0,0	0,0	0,0	0,0	0,0	0,0	0,0	0,0	0,0	0,0	0,0	0,0
Capacity/spot/FDM	Mb/s	3,456	3,456	3,072	3,456	3,456	3,456	3,456	3,456	3,456	3,456	3,456	3,456
Nb. Traffic Codes/FDM/Beam	-	9	9	8	9	9	9	9	9	9	9	9	9
Nb of codes on primary scrambling code	-	7	7	7	7	7	7	7	7	7	7	7	7
Nb of codes on secondary scrambling codes	-	2	2	1	2	2	2	2	2	2	2	2	2
Nb of Secondary Scrambling Codes/FDM/Beam	-	1	1	1	1	1	1	1	1	1	1	1	1
Satellite capacity (30 spots)	Mb/s	103,68	103,68	92,16	103,68	103,68	103,68	103,68	103,68	103,68	103,68	103,68	103,68
Spectrum efficiency as ITU	bit/s/Hz	0,738	0,738	0,656	0,738	0,738	0,738	0,738	0,738	0,738	0,738	0,738	0,738
Power efficiency as ITU		44,99%	44,93%	44,64%	44,99%	44,93%	44,90%	44,99%	44,93%	44,90%	44,99%	44,93%	44,90%

C.2 Uplink

The link budgets are evaluated with the common parameters summarized below.

Table C.9: Uplink link budget common parameters

Satellite Parameters				
Satellite Location	°E	13		
Orbital Height	Km	35 786		
Average No. of Overlapping Satellites		1		
Service Link				
Number of FDM's		1		
Number of Satellite Beams		30		
UE elevation	deg.	42	30	16
Slant Range	Km	37 629	38 612	39 958
Rx Antenna Gain	dB	47,0	44,0	42,5
System Noise Temperature	°K	550,0	550,0	550,0
Antenna C/I	dB	14,0	13,0	12,0
Link Parameters				
Uplink Frequency	MHz	1 995		
Availability (/year)	%	99,96		
Polarization (C/V/H)	C/V/H	C		
Chip Rate	Mchip/s	3,840		
Chip SRC Roll-off Factor		0,22		
Full FDM Bandwidth	MHz	4,68		
Total FDM Bandwidth	MHz	4,68		

The link budgets presented hereafter are calculated with the assumption MUD is implemented.

In all the subsequent tables, the dash columns indicate situations when link budget is not valid due to the fact the link margin would be negative. This means the system is not operable in those cases.

C.2.1 Data service 1,2 kbps

Table C.10: Uplink budget; Data service 1,2 kbps

RETURN LINK BUDGET		Handset			Portable			Véhicular			Transportable		
UE Elevation	deg.	42	30	16	42	30	16	42	30	16	42	30	16
Data Rate	bits/s	1 200	1 200	1 200	1 200	1 200	1 200	1 200	1 200	1 200	1 200	1 200	1 200
Traffic Activity Factor		1,00	1,00	1,00	1,00	1,00	1,00	1,00	1,00	1,00	1,00	1,00	1,00
Nominal Eb/No		7,45	7,45	7,45	7,45	7,45	7,45	7,45	7,45	7,45	7,45	7,45	7,45
MUD Improvement		no	no	no	no	no	no	no	no	no	no	no	no
Required Eb/(No+Io) per Finger	dB	7,45	7,45	7,45	7,45	7,45	7,45	7,45	7,45	7,45	7,45	7,45	7,45
Output power of Power Amplifier	W	0,25	0,25	0,25	2	2	2	8	8	8	2	2	2
Losses (Duplexer+line losses+filter+OBO)	dB	3,0	3,0	3,0	3,0	3,0	3,0	3,0	3,0	3,0	3,0	3,0	3,0
Total output power (@antenna access)	W	0,13	0,13	0,13	1,00	1,00	1,00	4,01	4,01	4,01	1,00	1,00	1,00
UE Antenna Gain	dB	0,00	0,00	0,00	2,00	2,00	2,00	4,00	4,00	4,00	14,00	14,00	14,00
Total Available EIRP	dBW	-9,02	-9,02	-9,02	2,01	2,01	2,01	10,03	10,03	10,03	14,01	14,01	14,01
EIRP / Traffic code	dBW	-10,89	-10,89	-10,89	0,14	0,14	0,14	8,16	8,16	8,16	12,14	12,14	12,14
Control/Data Power Ratio	dB	-2,69	-2,69	-2,69	-2,69	-2,69	-2,69	-2,69	-2,69	-2,69	-2,69	-2,69	-2,69
Control Equivalent Traffic Codes	0	0,54	0,54	0,54	0,54	0,54	0,54	0,54	0,54	0,54	0,54	0,54	0,54
Physical channel EIRP	dBW	-13,58	-13,58	-13,58	-2,55	-2,55	-2,55	5,47	5,47	5,47	9,45	9,45	9,45
Total required EIRP	dBW	-9,02	-9,02	-9,02	2,01	2,01	2,01	10,03	10,03	10,03	14,01	14,01	14,01
Power Density	dB/Hz	-75,7	-75,7	-75,7	-66,7	-66,7	-66,7	-60,7	-60,7	-60,7	-66,7	-66,7	-66,7
EIRP margin	dBW	0,00	0,00	0,00	0,00	0,00	0,00	0,00	0,00	0,00	0,00	0,00	0,00
Losses (Free space, rain, atmo., polarisation, pointing)	dB	190,5	190,8	191,1	190,5	190,8	191,1	190,5	190,8	191,1	190,5	190,8	191,1
Satellite Rx Antenna Gain	dB	47,0	44,0	42,5	47,0	44,0	42,5	47,0	44,0	42,5	47,0	44,0	42,5
Satellite G/T	dB/K	19,6	16,6	15,1	19,6	16,6	15,1	19,6	16,6	15,1	19,6	16,6	15,1
Thermal Noise Density, No	dBW/Hz	-201,2	-201,2	-201,2	-201,2	-201,2	-201,2	-201,2	-201,2	-201,2	-201,2	-201,2	-201,2
Interference per channel (same spot)	dBW	-127,9	-132,1	-135,2	-116,2	-119,5	-121,5	-108,1	-111,4	-113,4	-104,2	-107,4	-109,4
Interference per channel (adjacent spot)	dBW	-141,9	-145,1	-147,2	-130,2	-132,5	-133,5	-122,1	-124,4	-125,4	-118,1	-120,4	-121,4
Total Interference per Channel	dBW	-127,7	-131,9	-134,9	-116,0	-119,3	-121,3	-108,0	-111,2	-113,1	-104,0	-107,2	-109,1
-10*LOG(Spreading Bandwidth)	dB/Hz	-65,8	-65,8	-65,8	-65,8	-65,8	-65,8	-65,8	-65,8	-65,8	-65,8	-65,8	-65,8
Interference Density @ LNA, Io	dBW/Hz	-193,5	-197,7	-200,8	-181,9	-185,2	-187,1	-173,8	-177,1	-178,9	-169,8	-173,1	-174,9
10*log(No+Io)	dBW/Hz	-192,9	-196,1	-198,0	-181,8	-185,1	-186,9	-173,8	-177,0	-178,9	-169,8	-173,1	-174,9
Rx power / traffic code (@ LNA level)	dB	-154,4	-157,7	-159,5	-143,4	-146,6	-148,5	-135,4	-138,6	-140,5	-131,4	-134,6	-136,5
Uplink C/(No+Io)	dBHz	38,4	38,4	38,4	38,4	38,4	38,4	38,4	38,4	38,4	38,4	38,4	38,4
Uplink Eb/(No+Io)	dB	7,7	7,7	7,7	7,6	7,6	7,7	7,7	7,6	7,7	7,7	7,6	7,7
Feeder link degradation Eb/No Losses	dB	0,2	0,2	0,2	0,2	0,2	0,2	0,2	0,2	0,2	0,2	0,2	0,2
Overall Link Single Finger Eb/(No+Io)	dB	7,45	7,45	7,45	7,45	7,45	7,46	7,45	7,45	7,45	7,46	7,45	7,45
Total C/(N+I)	dB	-28,5	-28,5	-28,5	-28,5	-28,5	-28,5	-28,5	-28,5	-28,5	-28,5	-28,5	-28,5
Margin for Bent Pipe	dB	0,00	0,00	0,00	0,00	0,00	0,01	0,00	0,00	0,00	0,01	0,00	0,00
Capacity													
No. Traffic Codes/FDM/spot	-	294	236	177	341	333	324	344	340	335	344	341	336
Spot capacity/FDM	kbps	353	283	212	409	400	389	413	408	402	413	409	403
Satellite Capacity	Mbps	11	8	6	12	12	12	12	12	12	12	12	12
Spectrum efficiency as ITU	bit/s/Hz	0,08	0,06	0,05	0,09	0,09	0,08	0,09	0,09	0,09	0,09	0,09	0,09
Power efficiency as ITU	%	18%	18%	18%	18%	18%	18%	18%	18%	18%	18%	18%	18%

C.2.2 Speech service 4,75 kbps

Table C.11: Uplink budget; Speech 4,75 kbps

RETURN LINK BUDGET		Handset			Portable			Véhicular			Transportable		
UE Elevation	deg.	42	30	16	42	30	16	42	30	16	42	30	16
Data Rate	bit/s	4 750	4 750	4 750	4 750	4 750	4 750	4 750	4 750	4 750	4 750	4 750	4 750
Traffic Activity Factor		0,50	0,50	0,50	0,50	0,50	0,50	0,50	0,50	0,50	0,50	0,50	0,50
Nominal Eb/No		6,00	6,00	6,00	6,00	6,00	6,00	6,00	6,00	6,00	6,00	6,00	6,00
MUD Improvement		YES	YES	YES	YES	YES	YES	YES	YES	YES	YES	YES	YES
Required Eb/(No+Io) per Finger	dB	3,20	3,20	3,20	3,20	3,20	3,20	3,20	3,20	3,20	3,20	3,20	3,20
Output power of Power Amplifier	W	0,25	0,25	0,25	2	2	2	8	8	8	2	2	2
Losses (Duplexer+line losses+filter+OBO)	dB	3,0	3,0	3,0	3,0	3,0	3,0	3,0	3,0	3,0	3,0	3,0	3,0
Total output power (@antenna access)	W	0,13	0,13	0,13	1,00	1,00	1,00	4,01	4,01	4,01	1,00	1,00	1,00
UE Antenna Gain	dB	0,00	0,00	0,00	2,00	2,00	2,00	4,00	4,00	4,00	14,00	14,00	14,00
Total Available EIRP	dBW	-9,02	-9,02	-9,02	2,01	2,01	2,01	10,03	10,03	10,03	14,01	14,01	14,01
EIRP / Traffic code	dBW	-10,89	-10,89	-10,89	0,14	0,14	0,14	8,16	8,16	8,16	12,14	12,14	12,14
Control/Data Power Ratio	dB	-2,69	-2,69	-2,69	-2,69	-2,69	-2,69	-2,69	-2,69	-2,69	-2,69	-2,69	-2,69
Control Equivalent Traffic Codes	0	0,54	0,54	0,54	0,54	0,54	0,54	0,54	0,54	0,54	0,54	0,54	0,54
Physical channel EIRP	dBW	-13,58	-13,58	-13,58	-2,55	-2,55	-2,55	5,47	5,47	5,47	9,45	9,45	9,45
Total required EIRP	dBW	-9,02	-9,02	-9,02	2,01	2,01	2,01	10,03	10,03	10,03	14,01	14,01	14,01
Power Density	dB/Hz	-75,7	-75,7	-75,7	-66,7	-66,7	-66,7	-60,7	-60,7	-60,7	-66,7	-66,7	-66,7
EIRP margin	dBW	0,00	0,00	0,00	0,00	0,00	0,00	0,00	0,00	0,00	0,00	0,00	0,00
Losses (Free space, rain, atmo., polarisation, pointing)	dB	190,5	190,8	191,1	190,5	190,8	191,1	190,5	190,8	191,1	190,5	190,8	191,1
Satellite Rx Antenna Gain	dB	47,0	44,0	42,5	47,0	44,0	42,5	47,0	44,0	42,5	47,0	44,0	42,5
Satellite G/T	dB/K	19,6	16,6	15,1	19,6	16,6	15,1	19,6	16,6	15,1	19,6	16,6	15,1
Thermal Noise Density, No	dBW/Hz	-201,2	-201,2	-201,2	-201,2	-201,2	-201,2	-201,2	-201,2	-201,2	-201,2	-201,2	-201,2
Interference per channel (same spot)	dBW	-130,0	-134,9	-139,5	-118,6	-121,9	-123,8	-110,6	-113,9	-115,7	-106,6	-109,9	-111,8
Interference per channel (adjacent spot)	dBW	-143,9	-147,8	-151,4	-132,6	-134,9	-135,8	-124,6	-126,9	-127,7	-120,6	-122,9	-123,8
Total Interference per Channel	dBW	-129,8	-134,7	-139,2	-118,5	-121,7	-123,5	-110,5	-113,7	-115,5	-106,5	-109,7	-111,5
-10*LOG(Spreading Bandwidth)	dB/Hz	-65,8	-65,8	-65,8	-65,8	-65,8	-65,8	-65,8	-65,8	-65,8	-65,8	-65,8	-65,8
Interference Density @ LNA, Io	dBW/Hz	-195,6	-200,5	-205,0	-184,3	-187,5	-189,3	-176,3	-179,5	-181,3	-172,3	-175,5	-177,3
10*log(No+Io)	dBW/Hz	-194,6	-197,8	-199,7	-184,2	-187,3	-189,1	-176,3	-179,5	-181,3	-172,3	-175,5	-177,3
Rx power / traffic code (@ LNA level)	dB	-154,4	-157,7	-159,5	-143,4	-146,6	-148,5	-135,4	-138,6	-140,5	-131,4	-134,6	-136,5
Uplink C/(No+Io)	dBHz	40,2	40,2	40,2	40,9	40,7	40,6	40,9	40,9	40,8	40,9	40,9	40,8
Uplink Eb/(No+Io)	dB	3,4	3,4	3,4	4,1	4,0	3,8	4,2	4,1	4,0	4,2	4,1	4,1
Feeder link degradation Eb/No Losses	dB	0,2	0,2	0,2	0,2	0,2	0,2	0,2	0,2	0,2	0,2	0,2	0,2
Overall Link Single Finger Eb/(No+Io)	dB	3,20	3,20	3,20	3,89	3,75	3,61	3,97	3,91	3,84	3,97	3,93	3,87
Total C/(N+I)	dB	-26,7	-26,7	-26,7	-26,0	-26,2	-26,3	-26,0	-26,0	-26,1	-26,0	-26,0	-26,1
Margin for Bent Pipe	dB	0,00	0,00	0,00	0,69	0,55	0,41	0,77	0,71	0,64	0,77	0,73	0,67
Capacity													
No. Traffic Codes/FDM/spot	-	363	248	133	387	387	387	387	387	387	387	387	387
Spot capacity/FDM	kbps	862	589	316	919	919	919	919	919	919	919	919	919
Satellite Capacity	Mbps	26	18	9	28	28	28	28	28	28	28	28	28
Spectrum efficiency as ITU	bit/s/Hz	0,09	0,06	0,03	0,10	0,10	0,10	0,10	0,10	0,10	0,10	0,10	0,10
Power efficiency as ITU	%	48%	48%	48%	41%	42%	44%	40%	41%	41%	40%	40%	41%

C.2.3 Speech service 12,2 kbps

Table C.12: Uplink budget; Speech 12,2 kbps

RETURN LINK BUDGET		Handset			Portable			Véhicular			Transportable		
UE Elevation	deg.	42	30	16	42	30	16	42	30	16	42	30	16
Data Rate	bit/s	12 200	12 200	12 200	12 200	12 200	12 200	12 200	12 200	12 200	12 200	12 200	12 200
Traffic Activity Factor		0,50	0,50	0,50	0,50	0,50	0,50	0,50	0,50	0,50	0,50	0,50	0,50
Nominal Eb/No		6,80	6,80	6,80	6,80	6,80	6,80	6,80	6,80	6,80	6,80	6,80	6,80
MUD Improvement		YES	YES	YES	YES	YES	YES	YES	YES	YES	YES	YES	YES
Required Eb/(No+Io) per Finger	dB	4,00	4,00	4,00	4,00	4,00	4,00	4,00	4,00	4,00	4,00	4,00	4,00
Output power of Power Amplifier	W	0,25	0,25	0,25	2	2	2	8	8	8	2	2	2
Losses (Duplexer+line losses+filter+OBO)	dB	3,0	3,0	3,0	3,0	3,0	3,0	3,0	3,0	3,0	3,0	3,0	3,0
Total output power (@antenna access)	W	0,13	0,13	0,13	1,00	1,00	1,00	4,01	4,01	4,01	1,00	1,00	1,00
UE Antenna Gain	dB	0,00	0,00	0,00	2,00	2,00	2,00	4,00	4,00	4,00	14,00	14,00	14,00
Total Available EIRP	dBW	-9,02	-9,02	-9,02	2,01	2,01	2,01	10,03	10,03	10,03	14,01	14,01	14,01
EIRP / Traffic code	dBW	-10,89	-	-	0,14	0,14	0,14	8,16	8,16	8,16	12,14	12,14	12,14
Control/Data Power Ratio	dB	-2,69	-	-	-2,69	-2,69	-2,69	-2,69	-2,69	-2,69	-2,69	-2,69	-2,69
Control Equivalent Traffic Codes	0	0,54	-	-	0,54	0,54	0,54	0,54	0,54	0,54	0,54	0,54	0,54
Physical channel EIRP	dBW	-13,58	-	-	-2,55	-2,55	-2,55	5,47	5,47	5,47	9,45	9,45	9,45
Total required EIRP	dBW	-9,02	-	-	2,01	2,01	2,01	10,03	10,03	10,03	14,01	14,01	14,01
Power Density	dB/Hz	-75,7	-	-	-66,7	-66,7	-66,7	-60,7	-60,7	-60,7	-66,7	-66,7	-66,7
EIRP margin	dBW	0,00	-	-	0,00	0,00	0,00	0,00	0,00	0,00	0,00	0,00	0,00
Losses (Free space, rain, atmos.,polarisation,pointing)	dB	190,5	-	-	190,5	190,8	191,1	190,5	190,8	191,1	190,5	190,8	191,1
Satellite Rx Antenna Gain	dB	47,0	-	-	47,0	44,0	42,5	47,0	44,0	42,5	47,0	44,0	42,5
Satellite G/T	dB/K	19,6	-	-	19,6	16,6	15,1	19,6	16,6	15,1	19,6	16,6	15,1
Thermal Noise Density, No	dBW/Hz	-201,2	-	-	-201,2	-201,2	-201,2	-201,2	-201,2	-201,2	-201,2	-201,2	-201,2
Interference per channel (same spot)	dBW	-138,6	-	-	-123,5	-126,8	-128,8	-115,5	-118,8	-120,6	-111,5	-114,8	-116,7
Interference per channel (adjacent spot)	dBW	-152,6	-	-	-137,5	-139,8	-140,8	-129,5	-131,7	-132,6	-125,5	-127,8	-128,6
Total Interference per Channel	dBW	-138,5	-	-	-123,4	-126,6	-128,5	-115,4	-118,6	-120,4	-111,4	-114,6	-116,4
-10*LOG(Spreading Bandwidth)	dB/Hz	-65,8	-	-	-65,8	-65,8	-65,8	-65,8	-65,8	-65,8	-65,8	-65,8	-65,8
Interference Density @ LNA, Io	dBW/Hz	-204,3	-	-	-189,2	-192,4	-194,4	-181,2	-184,4	-186,2	-177,2	-180,4	-182,2
10*log(No+Io)	dBW/Hz	-199,5	-	-	-189,0	-191,9	-193,6	-181,2	-184,3	-186,1	-177,2	-180,4	-182,2
Rx power / traffic code (@ LNA level)	dB	-154,4	-	-	-143,4	-146,6	-148,5	-135,4	-138,6	-140,5	-131,4	-134,6	-136,5
Uplink C/(No+Io)	dBHz	45,1	-	-	45,6	45,3	45,1	45,8	45,7	45,6	45,8	45,8	45,7
Uplink Eb/(No+Io)	dB	4,2	-	-	4,7	4,4	4,2	4,9	4,8	4,7	5,0	4,9	4,8
Feeder link degradation Eb/No Losses	dB	0,2	-	-	0,2	0,2	0,2	0,2	0,2	0,2	0,2	0,2	0,2
Overall Link Single Finger Eb/(No+Io)	dB	4,00	-	-	4,51	4,20	4,00	4,74	4,65	4,55	4,76	4,70	4,63
Total C/(N+I)	dB	-21,8	-	-	-21,3	-21,6	-21,8	-21,1	-21,2	-21,3	-21,1	-21,1	-21,2
Margin for Bent Pipe	dB	0,00	-	-	0,51	0,20	0,00	0,74	0,65	0,55	0,76	0,70	0,63
Capacity													
No. Traffic Codes/FDM/spot	-	50	-	-	126	126	122	126	126	126	126	126	126
Spot capacity/FDM	kbps	305	-	-	769	769	744	769	769	769	769	769	769
Satellite Capacity	Mbps	9	-	-	23	23	22	23	23	23	23	23	23
Spectrum efficiency as ITU	bit/s/Hz	0,03	-	-	0,08	0,08	0,08	0,08	0,08	0,08	0,08	0,08	0,08
Power efficiency as ITU	%	40%	-	-	35%	38%	40%	34%	34%	35%	33%	34%	34%

C.2.4 Data service 64 kbps

Table C.13: Uplink budget; Data 64 kbps

RETURN LINK BUDGET		Handset			Portable			Véhicular			Transportable		
UE Elevation	deg.	42	30	16	42	30	16	42	30	16	42	30	16
Data Rate	bit/s	64 000	64 000	64 000	64 000	64 000	64 000	64 000	64 000	64 000	64 000	64 000	64 000
Traffic Activity Factor		1,00	1,00	1,00	1,00	1,00	1,00	1,00	1,00	1,00	1,00	1,00	1,00
Nominal Eb/No		3,80	3,80	3,80	3,80	3,80	3,80	3,80	3,80	3,80	3,80	3,80	3,80
MUD Improvement		YES	YES	YES	YES	YES	YES	YES	YES	YES	YES	YES	YES
Required Eb/(No+Io) per Finger	dB	1,00	1,00	1,00	1,00	1,00	1,00	1,00	1,00	1,00	1,00	1,00	1,00
Output power of Power Amplifier	W	0,25	0,25	0,25	2	2	2	8	8	8	2	2	2
Losses (Duplexer+line losses+filter+OBO)	dB	3,0	3,0	3,0	3,0	3,0	3,0	3,0	3,0	3,0	3,0	3,0	3,0
Total output power (@antenna access)	W	0,13	0,13	0,13	1,00	1,00	1,00	4,01	4,01	4,01	1,00	1,00	1,00
UE Antenna Gain	dB	0,00	0,00	0,13	2,00	2,00	2,00	4,00	4,00	4,00	14,00	14,00	14,00
Total Available EIRP	dBW	-9,02	-9,02	-9,02	2,01	2,01	2,01	10,03	10,03	10,03	14,01	14,01	14,01
EIRP / Traffic code	dBW	-	-	-	0,92	0,92	0,92	8,94	8,94	8,94	12,92	12,92	12,92
Control/Data Power Ratio	dB	-	-	-	-5,46	-5,46	-5,46	-5,46	-5,46	-5,46	-5,46	-5,46	-5,46
Control Equivalent Traffic Codes	0	-	-	-	0,28	0,28	0,28	0,28	0,28	0,28	0,28	0,28	0,28
Physical channel EIRP	dBW	-	-	-	-4,54	-4,54	-4,54	3,48	3,48	3,48	7,46	7,46	7,46
Total required EIRP	dBW	-	-	-	2,01	2,01	2,01	10,03	10,03	10,03	14,01	14,01	14,01
Power Density	dB/Hz	-	-	-	-66,7	-66,7	-66,7	-60,7	-60,7	-60,7	-66,7	-66,7	-66,7
EIRP margin	dBW	-	-	-	0,00	0,00	0,00	0,00	0,00	0,00	0,00	0,00	0,00
Losses (Free space, rain, atmos., polarisation, pointing)	dB	-	-	-	190,5	190,8	191,1	190,5	190,8	191,1	190,5	190,8	191,1
Satellite Rx Antenna Gain	dB	-	-	-	47,0	44,0	42,5	47,0	44,0	42,5	47,0	44,0	42,5
Satellite G/T	dB/K	-	-	-	19,6	16,6	15,1	19,6	16,6	15,1	19,6	16,6	15,1
Thermal Noise Density, No	dBW/Hz	-	-	-	-201,2	-201,2	-201,2	-201,2	-201,2	-201,2	-201,2	-201,2	-201,2
Interference per channel (same spot)	dBW	-	-	-	-126,7	-130,8	-133,6	-118,3	-121,7	-123,7	-114,3	-117,6	-119,6
Interference per channel (adjacent spot)	dBW	-	-	-	-140,6	-143,6	-145,4	-132,2	-134,5	-135,6	-128,2	-130,4	-131,4
Total Interference per Channel	dBW	-	-	-	-126,6	-130,6	-133,3	-118,1	-121,5	-123,4	-114,1	-117,3	-119,3
-10*LOG(Spreading Bandwidth)	dB/Hz	-	-	-	-65,8	-65,8	-65,8	-65,8	-65,8	-65,8	-65,8	-65,8	-65,8
Interference Density @ LNA, Io	dBW/Hz	-	-	-	-192,4	-196,4	-199,2	-184,0	-187,3	-189,3	-180,0	-183,2	-185,1
10*log(No+Io)	dBW/Hz	-	-	-	-191,9	-195,2	-197,1	-183,9	-187,1	-189,0	-180,0	-183,1	-185,0
Rx power / traffic code (@ LNA level)	dB	-	-	-	-142,6	-145,8	-147,7	-134,6	-137,8	-139,7	-130,6	-133,8	-135,7
Uplink C/(No+Io)	dBHz	-	-	-	49,3	49,3	49,3	49,3	49,3	49,3	49,4	49,3	49,3
Uplink Eb/(No+Io)	dB	-	-	-	1,2	1,3	1,3	1,3	1,3	1,2	1,3	1,2	1,3
Feeder link degradation Eb/No Losses	dB	-	-	-	0,2	0,2	0,2	0,2	0,2	0,2	0,2	0,2	0,2
Overall Link Single Finger Eb/(No+Io)	dB	-	-	-	1,01	1,05	1,09	1,05	1,05	1,04	1,10	1,02	1,06
Total C/(N+I)	dB	-	-	-	-17,6	-17,6	-17,6	-17,6	-17,6	-17,6	-17,5	-17,6	-17,6
Margin for Bent Pipe	dB	-	-	-	0,01	0,05	0,09	0,05	0,05	0,04	0,10	0,02	0,06
Capacity													
No. Traffic Codes/FDM/spot	-	-	-	-	31	26	21	34	33	32	34	34	33
Spot capacity/FDM	kbps	-	-	-	1 984	1 664	1 344	2 176	2 112	2 048	2 176	2 176	2 112
Satellite Capacity	Mbps	-	-	-	60	50	40	65	63	61	65	65	63
Spectrum efficiency as ITU	bit/s/Hz	-	-	-	0,42	0,36	0,29	0,46	0,45	0,44	0,46	0,46	0,45
Power efficiency as ITU	%	-	-	-	79%	78%	78%	78%	79%	79%	78%	79%	78%

C.2.5 Data service 144 kbps

Table C.14: Uplink budget; Data 144 kbps

RETURN LINK BUDGET		Handset			Portable			Véhicular			Transportable		
UE Elevation	deg.	42	30	16	42	30	16	42	30	16	42	30	16
Data Rate	bit/s	144 000	144 000	144 000	144 000	144 000	144 000	144 000	144 000	144 000	144 000	144 000	144 000
Traffic Activity Factor		1,00	1,00	1,00	1,00	1,00	1,00	1,00	1,00	1,00	1,00	1,00	1,00
Nominal Eb/No		2,90	2,90	2,90	2,90	2,90	2,90	2,90	2,90	2,90	2,90	2,90	2,90
MUD Improvement		YES	YES	YES	YES	YES	YES	YES	YES	YES	YES	YES	YES
Required Eb/(No+Io) per Finger	dB	0,10	0,10	0,10	0,10	0,10	0,10	0,10	0,10	0,10	0,10	0,10	0,10
Output power of Power Amplifier	W	0,25	0,25	0,25	2	2	2	8	8	8	2	2	2
Losses (Duplexer+line losses+filter+OBO)	dB	3,0	3,0	3,0	3,0	3,0	3,0	3,0	3,0	3,0	3,0	3,0	3,0
Total output power (@antenna access)	W	0,13	0,13	0,13	1,00	1,00	1,00	4,01	4,01	4,01	1,00	1,00	1,00
UE Antenna Gain	dB	0,00	0,00	0,00	2,00	2,00	2,00	4,00	4,00	4,00	14,00	14,00	14,00
Total Available EIRP	dBW	-9,02	-9,02	-9,02	2,01	2,01	2,01	10,03	10,03	10,03	14,01	14,01	14,01
EIRP / Traffic code	dBW	-	-	-	1,55	1,55	1,55	9,57	9,57	9,57	13,55	13,55	13,55
Control/Data Power Ratio	dB	-	-	-	-9,54	-9,54	-9,54	-9,54	-9,54	-9,54	-9,54	-9,54	-9,54
Control Equivalent Traffic Codes	0	-	-	-	0,11	0,11	0,11	0,11	0,11	0,11	0,11	0,11	0,11
Physical channel EIRP	dBW	-	-	-	-7,99	-7,99	-7,99	0,03	0,03	0,03	4,01	4,01	4,01
Total required EIRP	dBW	-	-	-	2,01	2,01	2,01	10,03	10,03	10,03	14,01	14,01	14,01
Power Density	dB/Hz	-	-	-	-66,7	-66,7	-66,7	-60,7	-60,7	-60,7	-66,7	-66,7	-66,7
EIRP margin	dBW	-	-	-	0,00	0,00	0,00	0,00	0,00	0,00	0,00	0,00	0,00
Losses (Free space, rain, atmos., polarisation, pointing)	dB	-	-	-	190,5	190,8	191,1	190,5	190,8	191,1	190,5	190,8	191,1
Satellite Rx Antenna Gain	dB	-	-	-	47,0	44,0	42,5	47,0	44,0	42,5	47,0	44,0	42,5
Satellite G/T	dB/K	-	-	-	19,6	16,6	15,1	19,6	16,6	15,1	19,6	16,6	15,1
Thermal Noise Density, No	dBW/Hz	-	-	-	-201,2	-201,2	-201,2	-201,2	-201,2	-201,2	-201,2	-201,2	-201,2
Interference per channel (same spot)	dBW	-	-	-	-129,2	-133,6	-137,6	-120,5	-123,7	-125,8	-116,3	-119,5	-121,6
Interference per channel (adjacent spot)	dBW	-	-	-	-143,0	-146,3	-149,1	-134,3	-136,5	-137,6	-130,1	-132,3	-133,4
Total Interference per Channel	dBW	-	-	-	-129,0	-133,4	-137,3	-120,3	-123,5	-125,5	-116,1	-119,3	-121,3
-10*LOG(Spreading Bandwidth)	dB/Hz	-	-	-	-65,8	-65,8	-65,8	-65,8	-65,8	-65,8	-65,8	-65,8	-65,8
Interference Density @ LNA, Io	dBW/Hz	-	-	-	-194,9	-199,2	-203,1	-186,1	-189,3	-191,4	-182,0	-185,2	-187,2
10*log(No+Io)	dBW/Hz	-	-	-	-194,0	-197,1	-199,1	-186,0	-189,1	-191,0	-181,9	-185,0	-187,0
Rx power / traffic code (@ LNA level)	dB	-	-	-	-142,0	-145,2	-147,1	-133,9	-137,2	-139,1	-130,0	-133,2	-135,1
Uplink C/(No+Io)	dBHz	-	-	-	52,0	51,9	52,0	52,1	51,9	51,9	51,9	51,8	51,9
Uplink Eb/(No+Io)	dB	-	-	-	0,4	0,3	0,4	0,5	0,3	0,3	0,4	0,3	0,3
Feeder link degradation Eb/No Losses	dB	-	-	-	0,2	0,2	0,2	0,2	0,2	0,2	0,2	0,2	0,2
Overall Link Single Finger Eb/(No+Io)	dB	-	-	-	0,21	0,10	0,18	0,28	0,09	0,10	0,15	0,05	0,14
Total C/(N+I)	dB	-	-	-	-14,9	-15,0	-14,9	-14,8	-15,0	-15,0	-15,0	-15,1	-15,0
Margin for Bent Pipe	dB	-	-	-	0,11	0,00	0,08	0,18	0,00	0,00	0,05	0,00	0,04
Capacity													
No. Traffic Codes/FDM/spot	-	-	-	-	18	14	9	21	21	20	22	22	21
Spot capacity/FDM	kbps	-	-	-	2 592	2 016	1 296	3 024	3 024	2 880	3 168	3 168	3 024
Satellite Capacity	Mbps	-	-	-	78	60	39	91	91	86	95	95	91
Spectrum efficiency as ITU	bit/s/Hz	-	-	-	0,55	0,43	0,28	0,65	0,65	0,61	0,68	0,00	0,65
Power efficiency as ITU	%	-	-	-	95%	98%	96%	94%	98%	98%	97%	99%	97%

C.2.6 Data service 384 kbps

Table C.15: Uplink budget; Data 384 kbps

RETURN LINK BUDGET		Handset			Portable			Véhicular			Transportable		
UE Elevation	deg.	42	30	16	42	30	16	42	30	16	42	30	16
Data Rate	bit/s	384 000	384 000	384 000	384 000	384 000	384 000	384 000	384 000	384 000	384 000	384 000	384 000
Traffic Activity Factor		1,00	1,00	1,00	1,00	1,00	1,00	1,00	1,00	1,00	1,00	1,00	1,00
Nominal Eb/No		3,00	3,00	3,00	3,00	3,00	3,00	3,00	3,00	3,00	3,00	3,00	3,00
MUD Improvement		YES	YES	YES	YES	YES	YES	YES	YES	YES	YES	YES	YES
Required Eb/(No+Io) per Finger	dB	0,20	0,20	0,20	0,20	0,20	0,20	0,20	0,20	0,20	0,20	0,20	0,20
Output power of Power Amplifier	W	0,25	0,25	0,25	2	2	2	8	8	8	2	2	2
Losses (Duplexer+line losses+filter+OBO)	dB	3,0	3,0	3,0	3,0	3,0	3,0	3,0	3,0	3,0	3,0	3,0	3,0
Total output power (@antenna access)	W	0,13	0,13	0,13	1,00	1,00	1,00	4,01	4,01	4,01	1,00	1,00	1,00
UE Antenna Gain	dB	0,00	0,00	0,00	2,00	2,00	2,00	4,00	4,00	4,00	14,00	14,00	14,00
Total Available EIRP	dBW	-9,02	-9,02	-9,02	2,01	2,01	2,01	10,03	10,03	10,03	14,01	14,01	14,01
EIRP / Traffic code	dBW	-	-	-	1,55	-	-	9,57	9,57	9,57	13,55	13,55	13,55
Control/Data Power Ratio	dB	-	-	-	-9,54	-	-	-9,54	-9,54	-9,54	-9,54	-9,54	-9,54
Control Equivalent Traffic Codes	0	-	-	-	0,11	-	-	0,11	0,11	0,11	0,11	0,11	0,11
Physical channel EIRP	dBW	-	-	-	-7,99	-	-	0,03	0,03	0,03	4,01	4,01	4,01
Total required EIRP	dBW	-	-	-	2,01	-	-	10,03	10,03	10,03	14,01	14,01	14,01
Power Density	dB/Hz	-	-	-	-66,7	-	-	-60,7	-60,7	-60,7	-66,7	-66,7	-66,7
EIRP margin	dB	-	-	-	0,00	-	-	0,00	0,00	0,00	0,00	0,00	0,00
Losses (Free space, rain, atmos., polarisation, pointing)	dB	-	-	-	190,5	-	-	190,5	190,8	191,1	190,5	190,8	191,1
Satellite Rx Antenna Gain	dB	-	-	-	47,0	-	-	47,0	44,0	42,5	47,0	44,0	42,5
Satellite G/T	dB/K	-	-	-	19,6	-	-	19,6	16,6	15,1	19,6	16,6	15,1
Thermal Noise Density, No	dBW/Hz	-	-	-	-201,2	-	-	-201,2	-201,2	-201,2	-201,2	-201,2	-201,2
Interference per channel (same spot)	dBW	-	-	-	-135,5	-	-	-125,0	-129,0	-131,6	-121,1	-124,3	-126,2
Interference per channel (adjacent spot)	dBW	-	-	-	-148,5	-	-	-138,5	-141,3	-142,8	-134,5	-136,7	-137,6
Total Interference per Channel	dBW	-	-	-	-135,3	-	-	-124,8	-128,7	-131,3	-120,9	-124,1	-125,9
-10*LOG(Spreading Bandwidth)	dB/Hz	-	-	-	-65,8	-	-	-65,8	-65,8	-65,8	-65,8	-65,8	-65,8
Interference Density @ LNA, Io	dBW/Hz	-	-	-	-201,1	-	-	-190,7	-194,5	-197,1	-186,7	-189,9	-191,7
10*log(No+Io)	dBW/Hz	-	-	-	-198,1	-	-	-190,3	-193,7	-195,7	-186,6	-189,6	-191,3
Rx power / traffic code (@ LNA level)	dB	-	-	-	-142,0	-	-	-133,9	-137,2	-139,1	-130,0	-133,2	-135,1
Uplink C/(No+Io)	dBHz	-	-	-	56,2	-	-	56,4	56,5	56,6	56,6	56,4	56,2
Uplink Eb/(No+Io)	dB	-	-	-	0,3	-	-	0,5	0,7	0,8	0,7	0,5	0,3
Feeder link degradation Eb/No Losses	dB	-	-	-	0,2	-	-	0,2	0,2	0,2	0,2	0,2	0,2
Overall Link Single Finger Eb/(No+Io)	dB	-	-	-	0,14	-	-	0,33	0,46	0,60	0,55	0,34	0,13
Total C/(N+I)	dB	-	-	-	-10,7	-	-	-10,5	-10,4	-10,3	-10,3	-10,5	-10,7
Margin for Bent Pipe	dB	-	-	-	0,00	-	-	0,13	0,26	0,40	0,35	0,14	0,00
Capacity													
No. Traffic Codes/FDM/spot	-	-	-	-	5	-	-	8	7	6	8	8	8
Spot capacity/FDM	kbps	-	-	-	1 920	-	-	3 072	2 688	2 304	3 072	3 072	3 072
Satellite Capacity	Mbps	-	-	-	58	-	-	92	81	69	92	92	92
Spectrum efficiency as ITU	bit/s/Hz	-	-	-	0,00	-	-	0,66	0,57	0,49	0,66	0,66	0,00
Power efficiency as ITU	%	-	-	-	97%	-	-	93%	90%	87%	88%	93%	97%

Annex D: System capacity - detailed results

D.1 Downlink

D.1.1 Mobile Satellite environment, LOS

This clause presents system capacity per carrier per spot in mobile LOS environment.

Empty compartments indicate situations when the service can not be offered due to link budget failure (propagation margin not reached due to UE maximum E.I.R.P limitation).

D.1.1.1 Data service 1,2 kbps

Table D.1: System capacity; Mobile satellite channels/LOS; Data service 1,2 kbps; Downlink

Data rate (kbps)	Rural (ITU A)				Sub-urban (ITU B)				Urban (ITU C)			
	Capacity (kbps)	Nb traffic codes	Spectrum efficiency as ITU (bit/s/Hz)	Power efficiency as ITU	Capacity (kbps)	Nb traffic codes	Spectrum efficiency as ITU (bit/s/Hz)	Power efficiency as ITU	Capacity (kbps)	Nb traffic codes	Spectrum efficiency as ITU (bit/s/Hz)	Power efficiency as ITU
1,2												
Handset												
Max (40°)	374	312	0,08	3,75 %	356	297	0,08	3,01 %	326	272	0,07	1,78 %
Average (30°)	359	299	0,08	3,71 %	343	286	0,07	3,05 %	313	261	0,07	1,77 %
Min (16°)	344	287	0,07	3,73 %	329	274	0,07	3,02 %	275	229	0,06	1,80 %
Portable												
Max (40°)	380	317	0,08	3,72 %	364	303	0,08	3,04 %	332	277	0,07	1,78 %
Average (30°)	373	311	0,08	3,75 %	355	296	0,08	3,01 %	325	271	0,07	1,78 %
Min (16°)	364	303	0,08	3,72 %	347	289	0,07	3,00 %	318	265	0,07	1,80 %
Vehicular												
Max (40°)	382	318	0,08	3,73 %	364	303	0,08	3,01 %	334	278	0,07	1,80 %
Average (30°)	374	312	0,08	3,74 %	358	298	0,08	3,05 %	326	272	0,07	1,77 %
Min (16°)	366	305	0,08	3,72 %	349	291	0,07	3,02 %	319	266	0,07	1,77 %
Transportable												
Max (40°)	384	320	0,08	3,72 %	367	306	0,08	3,05 %	336	280	0,07	1,80 %
Average (30°)	379	316	0,08	3,71 %	362	302	0,08	3,03 %	331	276	0,07	1,76 %
Min (16°)	374	312	0,08	3,74 %	358	298	0,08	3,05 %	326	272	0,07	1,77 %

D.1.1.2 Speech service 4,75 kbps

Table D.2: System capacity; Mobile satellite channels/LOS; Speech 4,75 kbps; Downlink

Data rate (kbps)	Rural (ITU A)				Sub-urban (ITU B)				Urban (ITU C)			
	Capacity (kbps)	Nb traffic codes	Spectrum efficiency as ITU (bit/s/Hz)	Power efficiency as ITU	Capacity (kbps)	Nb traffic codes	Spectrum efficiency as ITU (bit/s/Hz)	Power efficiency as ITU	Capacity (kbps)	Nb traffic codes	Spectrum efficiency as ITU (bit/s/Hz)	Power efficiency as ITU
4,75												
Handset												
Max (40°)	912	384	0,19	7,68 %	843	355	0,18	6,24 %	722	304	0,15	3,68 %
Average (30°)	857	361	0,18	7,70 %	793	334	0,17	6,27 %	677	285	0,14	3,68 %
Min (16°)	805	339	0,17	7,68 %	746	314	0,16	6,27 %	637	268	0,14	3,69 %
Portable												
Max (40°)	943	397	0,20	7,68 %	867	365	0,19	6,13 %	746	314	0,16	3,67 %
Average (30°)	917	386	0,20	7,72 %	848	357	0,18	6,27 %	724	305	0,15	3,69 %
Min (16°)	888	374	0,19	7,71 %	822	346	0,18	6,27 %	701	295	0,15	3,67 %
Vehicular												
Max (40°)	948	399	0,20	7,71 %	876	369	0,19	6,26 %	748	315	0,16	3,66 %
Average (30°)	924	389	0,20	7,71 %	853	359	0,18	6,23 %	729	307	0,16	3,66 %
Min (16°)	898	378	0,19	7,70 %	829	349	0,18	6,22 %	710	299	0,15	3,69 %
Transportable												
Max (40°)	960	404	0,20	7,69 %	888	374	0,19	6,26 %	758	319	0,16	3,65 %
Average (30°)	948	399	0,20	7,69 %	876	369	0,19	6,24 %	751	316	0,16	3,69 %
Min (16°)	933	393	0,20	7,68 %	865	364	0,18	6,26 %	739	311	0,16	3,68 %

D.1.1.3 Speech service 12,2 kbps

Table D.3: System capacity; Mobile satellite channels/LOS; Speech 12,2 kbps; Downlink

Data rate (kbps)	Rural (ITU A)				Sub-urban (ITU B)				Urban (ITU C)			
	Capacity (kbps)	Nb traffic codes	Spectrum efficiency as ITU (bit/s/Hz)	Power efficiency as ITU	Capacity (kbps)	Nb traffic codes	Spectrum efficiency as ITU (bit/s/Hz)	Power efficiency as ITU	Capacity (kbps)	Nb traffic codes	Spectrum efficiency as ITU (bit/s/Hz)	Power efficiency as ITU
12,2												
Handset												
Max (40°)	1 238	203	0,26	11,29 %	1 141	187	0,24	9,24 %	958	157	0,20	5,45 %
Average (30°)	1 159	190	0,25	11,26 %	1 068	175	0,23	9,18 %	897	147	0,19	5,37 %
Min (16°)	1 092	179	0,23	11,28 %	994	163	0,21	8,97 %	842	138	0,18	5,41 %
Portable												
Max (40°)	1 275	209	0,27	11,40 %	1 171	192	0,25	9,27 %	982	161	0,21	5,44 %
Average (30°)	1 226	201	0,26	11,38 %	1 122	184	0,24	9,19 %	946	155	0,20	5,45 %
Min (16°)	1 171	192	0,25	11,21 %	1 080	177	0,23	9,20 %	909	149	0,19	5,43 %
Vehicular												
Max (40°)	1 287	211	0,27	11,39 %	1 177	193	0,25	9,20 %	994	163	0,21	5,45 %
Average (30°)	1 251	205	0,27	11,39 %	1 147	188	0,24	9,22 %	964	158	0,21	5,43 %
Min (16°)	1 208	198	0,26	11,26 %	1 110	182	0,24	9,17 %	933	153	0,20	5,38 %
Transportable												
Max (40°)	1 299	213	0,28	11,25 %	1 196	196	0,26	9,18 %	1 007	165	0,21	5,39 %
Average (30°)	1 287	211	0,27	11,34 %	1 177	193	0,25	9,11 %	994	163	0,21	5,41 %
Min (16°)	1 269	208	0,27	11,37 %	1 165	191	0,25	9,23 %	976	160	0,21	5,34 %

D.1.1.4 Data service 64 kbps

Table D.4: System capacity; Mobile satellite channels/LOS; 64 kbps; Downlink

Data rate (kbps)	Rural (ITU A)				Sub-urban (ITU B)				Urban (ITU C)			
	Capacity (kbps)	Nb traffic codes	Spectrum efficiency as ITU (bit/s/Hz)	Power efficiency as ITU	Capacity (kbps)	Nb traffic codes	Spectrum efficiency as ITU (bit/s/Hz)	Power efficiency as ITU	Capacity (kbps)	Nb traffic codes	Spectrum efficiency as ITU (bit/s/Hz)	Power efficiency as ITU
64												
Handset												
Max (40°)	2 432	38	0,52	24,65 %	2 304	36	0,49	20,17 %	2 112	33	0,45	11,83 %
Average (30°)	2 304	36	0,49	24,38 %	2 240	35	0,48	20,23 %	1 984	31	0,42	11,77 %
Min (16°)	2 240	35	0,48	24,88 %	2 112	33	0,45	20,05 %	1 792	28	0,38	11,80 %
Portable												
Max (40°)	2 432	38	0,52	24,65 %	2 368	37	0,51	20,26 %	2 112	33	0,45	11,83 %
Average (30°)	2 368	37	0,51	24,70 %	2 304	36	0,49	20,23 %	2 048	32	0,44	11,76 %
Min (16°)	2 304	36	0,49	24,38 %	2 240	35	0,48	20,19 %	2 048	32	0,44	11,93 %
Vehicular												
Max (40°)	2 496	39	0,53	24,93 %	2 368	37	0,51	19,91 %	2 112	33	0,45	11,83 %
Average (30°)	2 432	38	0,52	24,93 %	2 304	36	0,49	20,04 %	2 112	33	0,45	11,73 %
Min (16°)	2 368	37	0,51	24,90 %	2 240	35	0,48	20,09 %	2 048	32	0,44	11,79 %
Transportable												
Max (40°)	2 496	39	0,53	24,43 %	2 368	37	0,51	19,91 %	2 176	34	0,46	11,72 %
Average (30°)	2 432	38	0,52	24,67 %	2 368	37	0,51	20,24 %	2 112	33	0,45	11,73 %
Min (16°)	2 432	38	0,52	24,73 %	2 304	36	0,49	19,96 %	2 112	33	0,45	11,84 %

D.1.1.5 Data service 144 kbps

Table D.5: System capacity; Mobile satellite channels/LOS; 144 kbps; Downlink

Data rate (kbps)	Rural (ITU A)				Sub-urban (ITU B)				Urban (ITU C)			
	Capacity (kbps)	Nb traffic codes	Spectrum efficiency as ITU (bit/s/Hz)	Power efficiency as ITU	Capacity (kbps)	Nb traffic codes	Spectrum efficiency as ITU (bit/s/Hz)	Power efficiency as ITU	Capacity (kbps)	Nb traffic codes	Spectrum efficiency as ITU (bit/s/Hz)	Power efficiency as ITU
144												
Handset												
Max (40°)	2 592	18	0,55	27,69 %	2 448	17	0,52	22,55 %	2 304	16	0,49	13,21 %
Average (30°)	2 448	17	0,52	27,91 %	2 448	17	0,52	22,49 %	2 160	15	0,46	13,31 %
Min (16°)	2 448	17	0,52	28,07 %	2 304	16	0,49	22,41 %	2 016	14	0,43	13,30 %
Portable												
Max (40°)	2 592	18	0,55	27,54 %	2 592	18	0,55	22,76 %	2 304	16	0,49	13,21 %
Average (30°)	2 592	18	0,55	28,05 %	2 448	17	0,52	22,49 %	2 160	15	0,46	13,31 %
Min (16°)	2 448	17	0,52	28,07 %	2 448	17	0,52	22,44 %	2 160	15	0,46	13,31 %
Vehicular												
Max (40°)	2 736	19	0,58	28,06 %	2 592	18	0,55	22,59 %	2 304	16	0,49	13,21 %
Average (30°)	2 592	18	0,55	27,67 %	2 448	17	0,52	22,49 %	2 304	16	0,49	13,35 %
Min (16°)	2 592	18	0,55	27,85 %	2 448	17	0,52	22,44 %	2 160	15	0,46	13,31 %
Transportable												
Max (40°)	2 736	19	0,58	28,06 %	2 592	18	0,55	22,59 %	2 304	16	0,49	13,21 %
Average (30°)	2 592	18	0,55	27,67 %	2 592	18	0,55	22,80 %	2 304	16	0,49	13,35 %
Min (16°)	2 592	18	0,55	27,85 %	2 448	17	0,52	22,44 %	2 304	16	0,49	13,44 %

D.1.1.6 Data service 384 kbps

Table D.6: System capacity; Mobile satellite channels/LOS; Speech 384 kbps; Downlink

Data rate (kbps)	Rural (ITU A)				Sub-urban (ITU B)				Urban (ITU C)			
	Capacity (kbps)	Nb traffic codes	Spectrum efficiency as ITU (bit/s/Hz)	Power efficiency as ITU	Capacity (kbps)	Nb traffic codes	Spectrum efficiency as ITU (bit/s/Hz)	Power efficiency as ITU	Capacity (kbps)	Nb traffic codes	Spectrum efficiency as ITU (bit/s/Hz)	Power efficiency as ITU
384												
Handset												
Max (40°)	3 072	8	0,66	27,64 %	2 688	7	0,57	22,48 %	2 688	7	0,57	13,19 %
Average (30°)	2 688	7	0,57	27,41 %	2 688	7	0,57	22,59 %	2 688	7	0,57	13,17 %
Min (16°)	2 688	7	0,57	27,48 %	2 688	7	0,57	22,63 %	1 920	5	0,41	13,16 %
Portable												
Max (40°)	3 072	8	0,66	27,64 %	3 072	8	0,66	22,44 %	2 688	7	0,57	13,19 %
Average (30°)	3 072	8	0,66	27,76 %	2 688	7	0,57	22,59 %	2 688	7	0,57	13,17 %
Min (16°)	2 688	7	0,57	27,48 %	2 688	7	0,57	22,63 %	2 688	7	0,57	13,05 %
Vehicular												
Max (40°)	3 072	8	0,66	27,64 %	3 072	8	0,66	22,44 %	2 688	7	0,57	13,19 %
Average (30°)	3 072	8	0,66	27,76 %	2 688	7	0,57	22,59 %	2 688	7	0,57	13,17 %
Min (16°)	3 072	8	0,66	27,41 %	2 688	7	0,57	22,63 %	2 688	7	0,57	13,05 %
Transportable												
Max (40°)	3 072	8	0,66	27,64 %	3 072	8	0,66	22,44 %	2 688	7	0,57	13,19 %
Average (30°)	3 072	8	0,66	27,76 %	3 072	8	0,66	22,41 %	2 688	7	0,57	13,17 %
Min (16°)	3 072	8	0,66	27,41 %	2 688	7	0,57	22,63 %	2 688	7	0,57	13,18 %

D.1.2 Mobile environment without LOS and/or indoor penetration

This clause presents system capacity in mobile environment and/or indoor penetration, i.e. for a 15 dB target link margin.

Grey compartments mean the 15 dB link margin is not reached for the corresponding UE configuration and elevation.

D.1.2.1 Data service 1,2 kbps

Table D.7: System capacity; Mobile environment/indoor penetration; Data service 1,2 kbps; Downlink

Data rate (kbps) 1,2	Capacity/ carrier/ spot (kbps)	Nb traffic codes/spot / carrier	Spectrum efficiency as ITU (bit/s/Hz)	Power efficiency as ITU	On board Power consumption (W)
Handset					
Max (40°)	0,056	47	0,01	0,39 %	195
Average (30°)	0,002	2	0,00	0,39 %	199
Min (16°)	0,002	2	0,00	0,54 %	199
Portable					
Max (40°)	0,110	92	0,02	0,38 %	200
Average (30°)	0,050	42	0,01	0,39 %	198
Min (16°)	0,014	12	0,00	0,38 %	199
Vehicular					
Max (40°)	0,119	99	0,03	0,39 %	200
Average (30°)	0,059	49	0,01	0,38 %	198
Min (16°)	0,022	18	0,00	0,38 %	198
Transportable					
Max (40°)	0,152	127	0,03	0,38 %	197
Average (30°)	0,100	83	0,02	0,38 %	199
Min (16°)	0,059	49	0,01	0,38 %	198

D.1.2.2 Speech service 4,75 kbps

Table D.8: System capacity; Mobile environment/indoor penetration; Speech 4,75 kbps; Downlink

Data rate (kbps) 4,75	Capacity/ carrier/ spot (kbps)	Nb traffic codes/spot / carrier	Spectrum efficiency as ITU (bit/s/Hz)	Power efficiency as ITU	On board Power consumption (W)
Handset					
Max (40°)	0,154	65	0,03	0,39 %	200
Average (30°)	0,064	27	0,01	0,39 %	196
Min (16°)	0,029	12	0,01	0,40 %	200
Portable					
Max (40°)	0,273	115	0,06	0,39 %	200
Average (30°)	0,157	66	0,03	0,39 %	198
Min (16°)	0,097	41	0,02	0,40 %	200
Vehicular					
Max (40°)	0,297	125	0,06	0,40 %	199
Average (30°)	0,178	75	0,04	0,39 %	199
Min (16°)	0,112	47	0,02	0,39 %	199
Transportable					
Max (40°)	0,404	170	0,09	0,39 %	199
Average (30°)	0,295	124	0,06	0,39 %	199
Min (16°)	0,211	89	0,05	0,39 %	199

D.1.2.3 Speech service 12,2 kbps

Table D.9: System capacity; Mobile environment/indoor penetration; Speech 12,2 kbps; Downlink

Data rate (kbps) 12,2	Capacity/ carrier/ spot (kbps)	Nb traffic codes/spot / carrier	Spectrum efficiency as ITU (bit/s/Hz)	Power efficiency as ITU	On board Power consumption (W)
Handset					
Max (40°)	226	37	0,05	0,58 %	198
Average (30°)	92	15	0,02	0,59 %	189
Min (16°)	37	6	0,01	0,58 %	190
Portable					
Max (40°)	342	56	0,07	0,58 %	195
Average (30°)	183	30	0,04	0,58 %	200
Min (16°)	104	17	0,02	0,58 %	199
Vehicular					
Max (40°)	415	68	0,09	0,58 %	200
Average (30°)	244	40	0,05	0,58 %	199
Min (16°)	153	25	0,03	0,58 %	199
Transportable					
Max (40°)	592	97	0,13	0,58 %	200
Average (30°)	427	70	0,09	0,58 %	196
Min (16°)	305	50	0,07	0,58 %	195

D.1.2.4 Data service 64 kbps

Table D.10: System capacity; Mobile environment/indoor penetration; Data 64 kbps; Downlink

Data rate (kbps) 64	Capacity/ carrier/ spot (kbps)	Nb traffic codes/spot / carrier	Spectrum efficiency as ITU (bit/s/Hz)	Power efficiency as ITU	Link Margin (dB)	On board Power consumption (W)
Handset						
Max (40°)	192	3	0,04	1,28 %	15,0	200
Average (30°)	64	1	0,01	1,52 %	14,2	200
Min (16°)	64	1	0,01	2,11 %	12,8	200
Portable						
Max (40°)	256	4	0,05	1,28 %	15,0	141
Average (30°)	128	2	0,03	1,32 %	14,8	199
Min (16°)	128	2	0,03	1,77 %	13,5	199
Vehicular						
Max (40°)	320	5	0,07	1,26 %	15,0	140
Average (30°)	128	2	0,03	1,28 %	15,0	138
Min (16°)	128	2	0,03	1,52 %	14,2	199
Transportable						
Max (40°)	448	7	0,10	1,27 %	15,0	47
Average (30°)	320	5	0,07	1,27 %	15,0	198
Min (16°)	192	3	0,04	1,28 %	14,9	199

D.1.2.5 Data service 144 kbps

Table D.11: System capacity; Mobile environment/indoor penetration; Data 144 kbps; Downlink

Data rate (kbps) 144	Capacity/ carrier/ spot (kbps)	Nb traffic codes/spot / carrier	Spectrum efficiency as ITU (bit/s/Hz)	Power efficiency as ITU	Link Margin (dB)	On board Power consumption (W)
Handset						
Max (40°)	144	1	0,03	1,42 %	15,0	151
Average (30°)	144	1	0,03	2,00 %	13,5	199
Min (16°)	144	1	0,03	2,79 %	12,1	199
Portable						
Max (40°)	288	2	0,06	1,44 %	15,0	141
Average (30°)	144	1	0,03	1,48 %	14,8	199
Min (16°)	144	1	0,03	2,00 %	13,5	199
Vehicular						
Max (40°)	288	2	0,06	1,44 %	15,0	89
Average (30°)	144	1	0,03	1,44 %	15,0	138
Min (16°)	144	1	0,03	1,71 %	14,2	199
Transportable						
Max (40°)	432	3	0,09	1,43 %	15,0	22
Average (30°)	288	2	0,06	1,43 %	15,0	45
Min (16°)	144	1	0,03	1,44 %	15,0	44

D.1.2.6 Data service 384 kbps

Table D.12: System capacity; Mobile environment/indoor penetration; Data 384 kbps; Downlink

Data rate (kbps) 384	Capacity/ carrier/ spot (kbps)	Nb traffic codes/spot / carrier	Spectrum efficiency as ITU (bit/s/Hz)	Power efficiency as ITU	Link Margin (dB)	On board Power consumption (W)
Handset						
Max (40°)	384	1	0,08	1,86 %	13,8	200
Average (30°)	384	1	0,08	2,95 %	11,8	200
Min (16°)	384	1	0,08	4,10 %	10,4	200
Portable						
Max (40°)	384	1	0,08	1,49 %	14,8	200
Average (30°)	384	1	0,08	2,19 %	13,1	200
Min (16°)	384	1	0,08	2,95 %	11,8	200
Vehicular						
Max (40°)	384	1	0,08	1,40 %	15,0	171
Average (30°)	384	1	0,08	1,90 %	13,7	200
Min (16°)	384	1	0,08	2,52 %	12,5	200
Transportable						
Max (40°)	384	1	0,08	1,40 %	15,0	17
Average (30°)	384	1	0,08	1,47 %	14,8	200
Min (16°)	384	1	0,08	1,86 %	13,8	200

D.1.3 IMR deployment

This clause presents system capacity in case of IMR deployment.

D.1.3.1 Data service 1,2 kbps

The required link margin is 3,9 dB.

Table D.13: System capacity; IMR deployment; Data service 1,2 kbps; Downlink

Data rate (kbps) 1,2	Capacity/ carrier/ spot (Mbps)	Nb traffic codes/spot / carrier	Spectrum efficiency as ITU (bit/s/Hz)	Power efficiency as ITU	On board Power consumption (W)
Handset					
Max (40°)	343	286	0,07	2,47 %	196
Average (30°)	329	274	0,07	2,43 %	200
Min (16°)	316	263	0,07	2,44 %	200
Portable					
Max (40°)	349	291	0,07	2,45 %	199
Average (30°)	342	285	0,07	2,46 %	200
Min (16°)	334	278	0,07	2,46 %	196
Vehicular					
Max (40°)	350	292	0,07	2,47 %	200
Average (30°)	343	286	0,07	2,45 %	200
Min (16°)	336	280	0,07	2,47 %	197
Transportable					
Max (40°)	353	294	0,08	2,47 %	201
Average (30°)	348	290	0,07	2,45 %	199
Min (16°)	343	286	0,07	2,46 %	196

D.1.3.2 Speech 4,75 kbps

The required link margin is 10 dB.

Table D.14: System capacity; IMR deployment; Speech 4,75 kbps; Downlink

Data rate (kbps) 4,75	Capacity/ carrier/ spot (Mbps)	Nb traffic codes/spot / carrier	Spectrum efficiency as ITU (bit/s/Hz)	Power efficiency as ITU	On board Power consumption (W)
Handset					
Max (40°)	753	317	0,16	4,33 %	198
Average (30°)	703	296	0,15	4,26 %	199
Min (16°)	663	279	0,14	4,31 %	200
Portable					
Max (40°)	777	327	0,17	4,29 %	199
Average (30°)	755	318	0,16	4,33 %	199
Min (16°)	732	308	0,16	4,34 %	197
Vehicular					
Max (40°)	781	329	0,17	4,33 %	200
Average (30°)	760	320	0,16	4,30 %	200
Min (16°)	736	310	0,16	4,25 %	199
Transportable					
Max (40°)	791	333	0,17	4,31 %	198
Average (30°)	781	329	0,17	4,32 %	196
Min (16°)	770	324	0,16	4,31 %	198

D.1.3.3 Speech 12,2 kbps

The required link margin is 10 dB.

Table D.15: System capacity; IMR deployment; Speech 12,2 kbps; Downlink

Data rate (kbps)	Capacity/ carrier/ spot (Mbps)	Nb traffic codes/spot / carrier	Spectrum efficiency as ITU (bit/s/Hz)	Power efficiency as ITU	On board Power consumption (W)
12,2					
Handset					
Max (40°)	787	129	0,17	1,83 %	194
Average (30°)	512	84	0,11	1,85 %	200
Min (16°)	329	54	0,07	1,85 %	198
Portable					
Max (40°)	805	132	0,17	1,82 %	172
Average (30°)	775	127	0,17	1,81 %	191
Min (16°)	555	91	0,12	1,84 %	200
Vehicular					
Max (40°)	817	134	0,17	1,84 %	196
Average (30°)	793	130	0,17	1,84 %	195
Min (16°)	720	118	0,15	1,84 %	198
Transportable					
Max (40°)	830	136	0,18	1,83 %	186
Average (30°)	817	134	0,17	1,81 %	196
Min (16°)	805	132	0,17	1,84 %	181

D.1.3.4 Data service 64 kbps

The required link margin is 11,5 dB.

Table D.16: System capacity; IMR deployment; Data 64 kbps; Downlink

Data rate (kbps)	Capacity/ carrier/ spot (Mbps)	Nb traffic codes/spot / carrier	Spectrum efficiency as ITU (bit/s/Hz)	Power efficiency as ITU	On board Power consumption (W)
64					
Handset					
Max (40°)	768	12	0,16	2,84 %	181
Average (30°)	384	6	0,08	2,84 %	194
Min (16°)	192	3	0,04	2,83 %	199
Portable					
Max (40°)	1 088	17	0,23	2,85 %	200
Average (30°)	640	10	0,14	2,85 %	197
Min (16°)	384	6	0,08	2,83 %	194
Vehicular					
Max (40°)	1 216	19	0,26	2,85 %	190
Average (30°)	768	12	0,16	2,84 %	190
Min (16°)	512	8	0,11	2,85 %	195
Transportable					
Max (40°)	1 472	23	0,31	2,80 %	176
Average (30°)	1 088	17	0,23	2,81 %	174
Min (16°)	768	12	0,16	2,83 %	107

D.1.3.5 Data service 144 kbps

The required link margin is 11,7 dB.

Table D.17: System capacity; IMR deployment; Data 144 kbps; Downlink

Data rate (kbps) 144	Capacity/ carrier/ spot (Mbps)	Nb traffic codes/spot / carrier	Spectrum efficiency as ITU (bit/s/Hz)	Power efficiency as ITU	On board Power consumption (W)
Handset					
Max (40°)	864	6	0,18	3,08 %	200
Average (30°)	288	2	0,06	3,05 %	148
Min (16°)	144	1	0,03	3,02 %	174
Portable					
Max (40°)	1 152	8	0,25	3,06 %	199
Average (30°)	576	4	0,12	3,05 %	155
Min (16°)	288	2	0,06	3,03 %	138
Vehicular					
Max (40°)	1 296	9	0,28	3,05 %	199
Average (30°)	720	5	0,15	3,05 %	145
Min (16°)	432	3	0,09	3,05 %	137
Transportable					
Max (40°)	1 584	11	0,34	3,07 %	120
Average (30°)	1 152	8	0,25	3,03 %	166
Min (16°)	864	6	0,18	3,08 %	200

D.1.3.6 Data service 384 kbps

The required link margin is 12,5 dB.

Table D.18: System capacity; IMR deployment; Data 384 kbps; Downlink

Data rate (kbps) 384	Capacity/ carrier/ spot (Mbps)	Nb traffic codes/spot / carrier	Spectrum efficiency as ITU (bit/s/Hz)	Power efficiency as ITU	On board Power consumption (W)
Handset					
Max (40°)	384	1	0,08	2,51 %	105
Average (30°)	384	1	0,08	2,95 %	200
Min (16°)	384	1	0,08	4,10 %	200
Portable					
Max (40°)	768	2	0,16	2,51 %	140
Average (30°)	384	1	0,08	2,52 %	139
Min (16°)	384	1	0,08	2,95 %	200
Vehicular					
Max (40°)	768	2	0,16	2,53 %	86
Average (30°)	384	1	0,08	2,52 %	88
Min (16°)	384	1	0,08	2,52 %	200
Transportable					
Max (40°)	1 152	3	0,25	2,50 %	49
Average (30°)	768	2	0,16	2,52 %	41
Min (16°)	384	1	0,08	2,52 %	20

D.2 Uplink

D.2.1 Mobile Satellite environment, LOS

This clause presents system capacity per carrier per spot in mobile LOS environment.

Empty compartments indicate situations when the service can not be offered due to link budget failure (propagation margin not reached due to UE maximum E.I.R.P limitation).

D.2.1.1 Data service 1,2 kbps

Table D.19: System capacity; Mobile satellite channels/LOS; Data service 1,2 kbps; Uplink

Data rate (kbps)	Rural (ITU A)				Sub-urban (ITU B)				Urban (ITU C)			
	Capacity (kbps)	Nb traffic codes	Spectrum efficiency as ITU (bit/s/Hz)	Power efficiency as ITU	Capacity (kbps)	Nb traffic codes	Spectrum efficiency as ITU (bit/s/Hz)	Power efficiency as ITU	Capacity (kbps)	Nb traffic codes	Spectrum efficiency as ITU (bit/s/Hz)	Power efficiency as ITU
1,2												
Handset												
Max (40°)	253,2	211	0,0540	13,62 %	190,8	159	0,0407	10,90 %	117,6	98	0,0251	7,71 %
Average (30°)	184,8	154	0,0394	13,64 %	122,4	102	0,0261	10,90 %	50,4	42	0,0108	7,72 %
Min (16°)	115,2	96	0,0246	13,64 %	54,0	45	0,0115	10,91 %	2,4	2	0,0005	8,61 %
Portable												
Max (40°)	309,6	258	0,0661	13,66 %	246,0	205	0,0525	10,89 %	174,0	145	0,0371	7,75 %
Average (30°)	301,2	251	0,0643	13,66 %	238,8	199	0,0510	10,91 %	166,8	139	0,0356	7,74 %
Min (16°)	292,8	244	0,0625	13,68 %	230,4	192	0,0492	10,90 %	159,6	133	0,0341	7,74 %
Vehicular												
Max (40°)	313,2	261	0,0669	13,64 %	250,8	209	0,0535	10,92 %	177,6	148	0,0379	7,73 %
Average (30°)	309,6	258	0,0661	13,66 %	247,2	206	0,0528	10,91 %	174,0	145	0,0371	7,68 %
Min (16°)	304,8	254	0,0651	13,65 %	243,6	203	0,0520	10,92 %	171,6	143	0,0366	7,71 %
Transportable												
Max (40°)	313,2	261	0,0669	13,62 %	250,8	209	0,0535	10,90 %	177,6	148	0,0379	7,71 %
Average (30°)	309,6	258	0,0661	13,61 %	248,4	207	0,0530	10,92 %	175,2	146	0,0374	7,69 %
Min (16°)	306,0	255	0,0653	13,64 %	244,8	204	0,0523	10,91 %	172,8	144	0,0369	7,70 %

D.2.1.2 Speech service 4,75 kbps

Table D.20: System capacity; Mobile satellite channels/LOS; Speech 4,75 kbps; Uplink

Data rate (kbps)	Rural (ITU A)				Sub-urban (ITU B)				Urban (ITU C)			
	Capacity (kbps)	Nb traffic codes	Spectrum efficiency as ITU (bit/s/Hz)	Power efficiency as ITU	Capacity (kbps)	Nb traffic codes	Spectrum efficiency as ITU (bit/s/Hz)	Power efficiency as ITU	Capacity (kbps)	Nb traffic codes	Spectrum efficiency as ITU (bit/s/Hz)	Power efficiency as ITU
4,75												
Handset												
Max (40°)	596,1	251	0,0636	36,32 %	489,3	206	0,0522	31,65 %	275,5	116	0,0294	22,33 %
Average (30°)	327,8	138	0,0350	36,32 %	220,9	93	0,0236	31,61 %	11,9	5	0,0013	22,41 %
Min (16°)	57,0	24	0,0061	36,28 %	4,8	2	0,0005	33,95 %	4,8	2	0,0005	33,95 %
Portable												
Max (40°)	817,0	344	0,0872	36,36 %	707,8	298	0,0755	31,59 %	496,4	209	0,0530	22,37 %
Average (30°)	788,5	332	0,0842	36,37 %	679,3	286	0,0725	31,56 %	470,3	198	0,0502	22,35 %
Min (16°)	755,3	318	0,0806	36,25 %	650,8	274	0,0695	31,59 %	444,1	187	0,0474	22,38 %
Vehicular												
Max (40°)	831,3	350	0,0887	36,29 %	724,4	305	0,0773	31,63 %	513,0	216	0,0548	22,41 %
Average (30°)	819,4	345	0,0875	36,27 %	712,5	300	0,0760	31,56 %	503,5	212	0,0537	22,35 %
Min (16°)	807,5	340	0,0862	36,33 %	700,6	295	0,0748	31,56 %	496,4	209	0,0530	22,46 %
Transportable												
Max (40°)	833,6	351	0,0890	36,31 %	726,8	306	0,0776	31,65 %	515,4	217	0,0550	22,43 %
Average (30°)	824,1	347	0,0880	36,31 %	717,3	302	0,0766	31,60 %	508,3	214	0,0542	22,40 %
Min (16°)	812,3	342	0,0867	36,29 %	707,8	298	0,0755	31,63 %	501,1	211	0,0535	22,42 %

D.2.1.3 Speech service 12,2 kbps

Table D.21: System capacity; Mobile satellite channels/LOS; Speech 12,2 kbps; Uplink

Data rate (kbps)	Rural (ITU A)				Sub-urban (ITU B)				Urban (ITU C)			
	Capacity (kbps)	Nb traffic codes	Spectrum efficiency as ITU (bit/s/Hz)	Power efficiency as ITU	Capacity (kbps)	Nb traffic codes	Spectrum efficiency as ITU (bit/s/Hz)	Power efficiency as ITU	Capacity (kbps)	Nb traffic codes	Spectrum efficiency as ITU (bit/s/Hz)	Power efficiency as ITU
12,2												
Handset												
Max (40°)	85,4	14	0,0091	30,22 %	12,2	2	0,0013	27,02 %	12,2	2	0,0013	27,02 %
Average (30°)	-	-	-	-	-	-	-	-	-	-	-	-
Min (16°)	-	-	-	-	-	-	-	-	-	-	-	-
Portable												
Max (40°)	646,6	106	0,0690	30,06 %	561,2	92	0,0599	26,33 %	384,3	63	0,0410	18,62 %
Average (30°)	585,6	96	0,0625	29,99 %	500,2	82	0,0534	26,23 %	329,4	54	0,0352	18,71 %
Min (16°)	524,6	86	0,0560	29,99 %	439,2	72	0,0469	26,19 %	268,4	44	0,0286	18,57 %
Vehicular												
Max (40°)	689,3	113	0,0736	30,14 %	597,8	98	0,0638	26,15 %	427,0	70	0,0456	18,70 %
Average (30°)	671,0	110	0,0716	30,00 %	585,6	96	0,0625	26,24 %	414,8	68	0,0443	18,72 %
Min (16°)	658,8	108	0,0703	30,20 %	567,3	93	0,0605	26,12 %	396,5	65	0,0423	18,51 %
Transportable												
Max (40°)	695,4	114	0,0742	30,21 %	603,9	99	0,0645	26,22 %	427,0	70	0,0456	18,50 %
Average (30°)	683,2	112	0,0729	30,12 %	597,8	98	0,0638	26,36 %	420,9	69	0,0449	18,57 %
Min (16°)	671,0	110	0,0716	30,10 %	585,6	96	0,0625	26,29 %	414,8	68	0,0443	18,67 %

D.2.1.4 Data service 64 kbps

64 kbps data service is not accessible to Handset UE configuration in mobile satellite environment.

Table D.22: System capacity; Mobile satellite channels/LOS; Data 64 kbps; Uplink

Data rate (kbps)	Rural (ITU A)				Sub-urban (ITU B)				Urban (ITU C)			
	Capacity (kbps)	Nb traffic codes	Spectrum efficiency as ITU (bit/s/Hz)	Power efficiency as ITU	Capacity (kbps)	Nb traffic codes	Spectrum efficiency as ITU (bit/s/Hz)	Power efficiency as ITU	Capacity (kbps)	Nb traffic codes	Spectrum efficiency as ITU (bit/s/Hz)	Power efficiency as ITU
64												
Portable												
Max (40°)	1 408,0	22	0,3005	58,29 %	1 216,0	19	0,2596	51,29 %	832,0	13	0,1776	37,31 %
Average (30°)	1 152,0	18	0,2459	59,66 %	960,0	15	0,2049	52,59 %	512,0	8	0,1093	36,12 %
Min (16°)	832,0	13	0,1776	58,79 %	640,0	10	0,1366	51,64 %	256,0	4	0,0546	37,35 %
Vehicular												
Max (40°)	1 664,0	26	0,3552	59,82 %	1 472,0	23	0,3142	52,83 %	1 024,0	16	0,2186	36,51 %
Average (30°)	1 600,0	25	0,3415	59,69 %	1 408,0	22	0,3005	52,63 %	960,0	15	0,2049	36,15 %
Min (16°)	1 536,0	24	0,3279	59,69 %	1 344,0	21	0,2869	52,54 %	896,0	14	0,1913	35,86 %
Transportable												
Max (40°)	1 664,0	26	0,3552	58,94 %	1 472,0	23	0,3142	51,95 %	1 024,0	16	0,2186	35,64 %
Average (30°)	1 664,0	26	0,3552	60,19 %	1 472,0	23	0,3142	53,13 %	1 024,0	16	0,2186	36,65 %
Min (16°)	1 600,0	25	0,3415	59,23 %	1 408,0	22	0,3005	52,08 %	1 024,0	16	0,2186	37,78 %

D.2.1.5 Data service 144 kbps

144 kbps data service is not accessible to Handset UE configuration in mobile satellite environment.

Table D.23: System capacity; Mobile satellite channels/LOS; Data 144 kbps; Uplink

Data rate (kbps)	Rural (ITU A)				Sub-urban (ITU B)				Urban (ITU C)			
	Capacity (Mbps)	Nb traffic codes	Spectrum efficiency as ITU (bit/s/Hz)	Power efficiency as ITU	Capacity (Mbps)	Nb traffic codes	Spectrum efficiency as ITU (bit/s/Hz)	Power efficiency as ITU	Capacity (Mbps)	Nb traffic codes	Spectrum efficiency as ITU (bit/s/Hz)	Power efficiency as ITU
144												
Portable												
Max (40°)	1 872,0	13	0,3996	72,62 %	1 584,0	11	0,3381	63,54 %	1 008,0	7	0,2152	45,40 %
Average (30°)	1 296,0	9	0,2766	74,87 %	1 008,0	7	0,2152	65,71 %	432,0	3	0,0922	47,38 %
Min (16°)	576,0	4	0,1230	72,68 %	288,0	2	0,0615	63,41 %	288,0	2	0,0615	63,41 %
Vehicular												
Max (40°)	2 448,0	17	0,5225	75,61 %	2 016,0	14	0,4303	61,99 %	1 440,0	10	0,3074	43,85 %
Average (30°)	2 304,0	16	0,4918	74,94 %	2 016,0	14	0,4303	65,78 %	1 296,0	9	0,2766	42,87 %
Min (16°)	2 160,0	15	0,4611	74,44 %	1 872,0	13	0,3996	65,17 %	1 296,0	9	0,2766	46,61 %
Transportable												
Max (40°)	2 448,0	17	0,5225	73,90 %	2 160,0	15	0,4611	64,83 %	1 584,0	11	0,3381	46,68 %
Average (30°)	2 304,0	16	0,4918	71,35 %	2 016,0	14	0,4303	62,18 %	1 440,0	10	0,3074	43,85 %
Min (16°)	2 304,0	16	0,4918	73,54 %	2 016,0	14	0,4303	64,27 %	1 440,0	10	0,3074	45,71 %

D.2.1.6 Data service 384 kbps

384 kbps data service is not accessible to Handset UE configuration in mobile satellite environment, and is only accessible to UE under 40° elevation for the portable configuration.

Table D.24: System capacity; Mobile satellite channels/LOS; Data 384 kbps; Uplink

Data rate (kbps)	Rural (ITU A)				Sub-urban (ITU B)				Urban (ITU C)			
	Capacity (kbps)	Nb traffic codes	Spectrum efficiency as ITU (bit/s/Hz)	Power efficiency as ITU	Capacity (kbps)	Nb traffic codes	Spectrum efficiency as ITU (bit/s/Hz)	Power efficiency as ITU	Capacity (kbps)	Nb traffic codes	Spectrum efficiency as ITU (bit/s/Hz)	Power efficiency as ITU
384												
Portable												
Max (40°)	1 152,0	3	0,2459	72,66 %	768,0	2	0,1639	60,56 %	768,0	2	0,1639	60,56 %
Average (30°)	-	-	-	-	-	-	-	-	-	-	-	-
Min (16°)	-	-	-	-	-	-	-	-	-	-	-	-
Vehicular												
Max (40°)	2 304,0	6	0,4918	68,53 %	1 920,0	5	0,4098	56,43 %	1 536,0	4	0,3279	44,33 %
Average (30°)	1 920,0	5	0,4098	65,44 %	1 920,0	5	0,4098	65,44 %	1 152,0	3	0,2459	41,01 %
Min (16°)	1 536,0	4	0,3279	62,45 %	1 536,0	4	0,3279	62,45 %	768,0	2	0,1639	37,71 %
Transportable												
Max (40°)	2 304,0	6	0,4918	63,98 %	2 304,0	6	0,4918	63,98 %	1 536,0	4	0,3279	39,79 %
Average (30°)	2 304,0	6	0,4918	68,07 %	1 920,0	5	0,4098	55,85 %	1 536,0	4	0,3279	43,63 %
Min (16°)	2 304,0	6	0,4918	72,42 %	1 920,0	5	0,4098	60,05 %	1 536,0	4	0,3279	47,68 %

Annex E: "W-CDMA" Radio transmission technologies description template

E.1 Test environment support

A1.1	Test environment support
A1.1.1	In what test environments will the RTT operate? Answer: The RTT will operate in the satellite test environment. Indoor test environment can be achieved either via Intermediate Module Repeaters or with a reduced radio system capacity.
A1.1.2	If the RTT supports more than one test environment, what test environment does this technology description template address? Answer: This template addresses the satellite test environment.
A1.1.3	Does the RTT include any features in support of FWA application? Provide detail about the impact of those features on the technical parameters provided in this template, stating whether the technical parameters provided apply for mobile as well as for FWA applications. Answer: The proposed RTT can accommodate fixed, portable, vehicular and personal (handheld) satellite terminals. The proposed RTT is flexible enough to accommodate a wide range of bearer services up to 384 kbit/s.

E.2 Technical parameters

A1.2	Technical parameters NOTE 1: Parameters for both forward link and reverse link should be described separately, if necessary.
A1.2.1	What is the minimum frequency band required to deploy the system (MHz)? Answer: The minimum required band is 2×5 MHz: 5 MHz for the user terminals to satellite links (uplink) + 5 MHz for the satellite to terminals links (downlink) Additional bandwidth is needed for the satellite to LES link (feeder links).
A1.2.2	What is the duplex method: TDD or FDD? Answer: The duplex method is FDD.
A1.2.2.1	What is the minimum up/down frequency separation for FDD? Answer: 190 MHz for the S-UMTS band. A lower minimum up/down link frequency separation is possible (see MSS bands).
A1.2.2.2	What is requirement of transmit/receive isolation? Does the proposal require a duplexer in either the mobile station (MS) or BS? Answer: A duplexer is required in the UE and LES. The UE duplexer Rx port shall attenuate the signals by 60 dB to 70 dB in the Tx frequency band. The corresponding LES duplexer attenuation shall be at least 80 dB.
A1.2.3	Does the RTT allow asymmetric transmission to use the available spectrum? Characterize. Answer: It is possible to use different options on the up and down link: a different number of codes and a different spreading factor.
A1.2.4	What is the RF channel spacing (kHz)? In addition, does the RTT use an interleaved frequency plan? NOTE 2: The use of the second adjacent channel instead of the adjacent channel at a neighbouring cluster cell is called "interleaved frequency planning". If a proponent is going to employ an interleaved frequency plan, the proponent should state so in section A1.2.4 and complete section A1.2.15 with the protection ratio for both the adjacent and second adjacent channel. Answer: The channel spacing is 4,68 MHz (chip rate: 3,84 Mcps, roll-off factor: 0,22). No interleaved frequency allocation is needed.

A1.2.5	<p>What is the bandwidth per duplex RF channel (MHz) measured at the 3 dB down points? It is given by (bandwidth per RF channel) \times (1 for TDD and 2 for FDD). Provide detail.</p> <p>Answer: 2 x 4,68 MHz (3,84 Mcps + Root Raised Cosinus roll-off 0,22).</p>
A1.2.5.1	<p>Does the proposal offer multiple or variable RF channel bandwidth capability? If so, are multiple bandwidths or variable bandwidths provided for the purposes of compensating the transmission medium for impairments but intended to be feature transparent to the end user?</p> <p>Answer: Not applicable.</p>
A1.2.6	<p>What is the RF channel bit rate (kbit/s)?</p> <p>NOTE 3: The maximum modulation rate of RF (after channel encoding, adding of in-band control signalling and any overhead signalling) possible to transmit carrier over an RF channel, i.e. independent of access technology and of modulation schemes.</p> <p>Answer: Downlink: the spreading factor is variable in the range 4 - 512, the channel bit rates provided are: 15 kbps, 30 kbps ... 1 920 kbps Uplink: the spreading factor is variable in the range 4 - 256, the channel bit rates provided are: 15 kbps, 30 kbps ... 960 kbps Multiple spreading codes can be allocated for higher transmission rates.</p>
A1.2.7	<p><i>Frame structure:</i> describe the frame structure to give sufficient information such as:</p> <ul style="list-style-type: none"> - frame length; - the number of time slots per frame; - guard time or the number of guard bits; - user information bit rate for each time slot; - channel bit rate (after channel coding); - channel symbol rate (after modulation); - associated control channel (ACCH) bit rate; - power control bit rate. <p>NOTE 4: Channel coding may include forward error correction (FEC), cyclic redundancy checking (CRC), ACCH, power control bits and guard bits. Provide detail.</p> <p>NOTE 5: Describe the frame structure for forward link and reverse link, respectively.</p> <p>NOTE 6: Describe the frame structure for each user information rate.</p> <p>Answer:</p> <ul style="list-style-type: none"> - Frame length: 10 ms - Number of time slots per frame: 15 (see system description) - Guard time: No guard time needed. - User information bit rate for each time slot: the user bit rate is variable on a frame by frame basis. The user information rate may vary from 2,4 kbps to 384 kbps. - Channel bit rate (after channel coding and rate matching): Downlink: 15 kbps / 30 kbps / 60 kbps / 120 kbps ... 1 920 kbps Uplink: 15 kbps / 30 kbps / 60 kbps / 120 kbps ... 960 kbps - Channel symbol rate (after modulation): 3,840 Mchip/s. - Associated control channel (ACCH) bit rate: DPCCCH: 15 kbps - Power-control bit rate: 1 500 Hz. <p>See system description for more details.</p>
A1.2.8	<p>Does the RTT use frequency hopping? If so, characterize and explain particularly the impact (e.g. improvements) on system performance.</p> <p>Answer: No frequency hopping is employed in the RTT proposal.</p>
A1.2.8.1	<p>What is the hopping rate?</p> <p>Answer: Not applicable.</p>
A1.2.8.2	<p>What is the number of the hopping frequency sets?</p> <p>Answer: Not applicable.</p>
A1.2.8.3	<p>Are BSs synchronized or non-synchronized?</p> <p>Answer: With the baseline scrambling code allocation strategy, LESs (and spots) do not need to be tightly synchronized.</p> <p>Accuracy in the order of 10 ms is adequate, to support system procedures like inter-spot handoff. Different scrambling code allocation strategies, envisaging the use of different offsets of the same scrambling code by different spots will require tighter synchronization (in the order of 1 ms).</p>
A1.2.9	<p>Does the RTT use a spreading scheme?</p> <p>Answer: The RTT uses direct sequence spreading.</p>
A1.2.9.1	<p>What is the chip rate (Mchip/s)? Rate at input to modulator.</p> <p>Answer: The chip rate input is 3,840 Mchip/s.</p>

A1.2.9.2	<p>What is the processing gain? $10 \log$ (chip rate/information rate).</p> <p>Answer: Considering the standard test services: speech 12,2 kbps, data 64 kbps to 384 kbps, the processing gain is ranging from 10 dB to 25 dB. For lower bit rates (see system description), i.e. 2,4 kbps, the processing gain is up to 32 dB.</p>
A1.2.9.3	<p>Explain the uplink and downlink code structures and provide the details about the types (e.g. personal numbering (PN) code, Walsh code) and purposes (e.g. spreading, identification, etc.) of the codes.</p> <p>Answer: Channelization codes: Orthogonal Variable Spreading Factor codes. UL: Spreading factor: 4 to 256 DL: Spreading factor: 4 to 512 UL Scrambling code: Dedicated physical channels: 24 bit long (Gold sequence) or short (extended S(2) scrambling codes PRACH preamble: restricted to 4 096 first chips PRACH message part: identical to dedicated physical channels DL Scrambling code: DL Primary scrambling code: 18 bit scrambling codes (Gold sequence) limited to 512 codes DL Secondary scrambling code: 18 bit scrambling codes (Gold sequence) Synchronization channel Scrambling code: code word with 256 chips from 16-chip sequence, not modulated. See System description for further detail.</p>
A1.2.10	<p>Which access technology does the proposal use: TDMA, FDMA, CDMA, hybrid, or a new technology? In the case of CDMA, which type of CDMA is used: frequency hopping (FH) or direct sequence (DS) or hybrid? Characterize.</p> <p>Answer: Direct sequence CDMA is employed.</p>
A1.2.11	<p>What is the base-band modulation technique? If both the data modulation and spreading modulation are required, describe in detail. What is the peak to average power ratio after base-band filtering (dB)?</p> <p>Answer: Modulation is QPSK. For both up and downlink, square root raised cosine filtering with roll-off 0,22 is used. See System description for further details.</p>
A1.2.12	<p>What is the channel coding (error handling) rate and form for both the forward and reverse links? E.g. does the RTT adopt:</p> <ul style="list-style-type: none"> - FEC or other schemes? - Unequal error protection? Provide details. - Soft decision decoding or hard decision decoding? Provide details. - Iterative decoding (e.g. turbo codes)? Provide details. - Other schemes? <p>Answer: Different classes of bearer services are supported. Depending on the quality bearer services: convolutional code with rate 1/2 or 1/3, $k = 9$, Rate 1/3 Turbo codes, or no FEC coding (in that case, error handling is directly provided by the application). Puncturing or unequal bit repetition is exploited to adapt the bearer service rate to the channel rate (rate matching feature).</p>
A1.2.13	<p>What is the bit interleaving scheme? Provide detailed description for both uplink and downlink.</p> <p>Answer: Default bit interleaving work perform block interleaving on a single signal frame (10 ms) 1st interleaving: on FEC blocks (inter frames interleaving) - depth: 20 ms, 40 ms or 80 ms. 2nd interleaving: on 10 ms frame (intra frame interleaving = bit interleaving).</p>
A1.2.14	<p>Describe the approach taken for the receivers (MS and BS) to cope with multi-path propagation effects (e.g. via equalizer, Rake receiver, etc.).</p> <p>Answer: The UE and the LES station will both utilize RAKE receivers. Usefulness of RAKE receiver in the satellite environment lies in the possibility to implement soft /softer handover as well as in the capability to exploit satellite diversity to improve the system power efficiency by decreasing the required link margins for a given service outage probability. Multi-path effects play a relatively minor role in the satellite environment.</p>

A1.2.14.1	<p>Describe the robustness to inter-symbol interference and the specific delay spread profiles that are best or worst for the proposal.</p> <p>Answer: Inter-symbol interference plays a minor role in the performance of the proposed RTT being significantly attenuated by the de-spreading process.</p> <p>The performances of the RTT is not significantly influenced by the particular wide-band channel model (channel A, B and C) proposed for the satellite component. Different paths (in channel models A, B and C) have, in fact, a too low delay spread to be separated or, if separable (in case of the 250 ns), delayed component for channel model B and C and full chip rate option, the associated amplitude appears too small to be effectively detected.</p>
A1.2.14.2	<p>Can rapidly changing delay spread profile be accommodated? Describe.</p> <p>Answer: Different paths (according to channel models A, B and C) have a too low delay spread to be separated.</p> <p>The satellite channel has to be considered non-dispersive with respect to the proposed RTT characteristics. The complex gain variation of the non frequency selective propagation channel can be tracked up to frequency of about 1 kHz thanks to the availability of reference symbols. Fast loop power control is not efficient enough for fast fading fighting.</p>
A1.2.15	<p>What is the adjacent channel protection ratio?</p> <p>NOTE 7: In order to maintain robustness to adjacent channel interference, the RTT should have some receiver characteristics that can withstand higher power adjacent channel interference. Specify the maximum allowed relative level of adjacent RF channel power (dBc). Provide detail how this figure is assumed.</p> <p>Answer: Adjacent Channel selectivity is 33 dB, Adjacent Channel Linkage Ratio is 45 dB. Lower values may result in a graceful degradation of performances and /or capacity. Somewhat higher protection ratios may be required in a non-uniform environment as a consequence of the band sharing between different operators utilizing satellite constellation having different characteristics.</p>
A1.2.16	Power classes
A1.2.16.1	<p><i>Mobile terminal emitted power</i>: what is the radiated antenna power measured at the antenna? For terrestrial component, give (dBm). For satellite component, the mobile terminal emitted power should be given in E.I.R.P. (effective isotropic radiated power) (dBm).</p>
A1.2.16.1.1	<p>What is the maximum peak power transmitted while in active or busy state?</p> <p>Answer:</p> <p>This parameter is not part of the present proposal and will depend on the space segment characteristics. As examples, the maximum power, antenna gain and E.I.R.P. that is envisaged for the different terminal classes are shown below.</p> <p>Maximum E.I.R.P.:</p> <p>Hand-held terminals: 23,9 dBm (250 mW) + 0 dBi = -6 dBW</p> <p>Portable terminals: 33 dBm (2 W) + 2 dBi = 5 dBW</p> <p>Vehicular terminals: 39 dBm (8 W) + 4 dBi = 13 dBW</p> <p>Transportable terminals: 33 dBm (2 W) + 14 dBi = 17 dBW</p>
A1.2.16.1.2	<p>What is the time average power transmitted while in active or busy state? Provide detailed explanation used to calculate this time average power.</p> <p>Answer: Transmission in the active state is continuous. Values quoted at the previous point only apply as far as the maximum transmitted power is concerned. Average power is not constrained by this RTT proposal.</p>
A1.2.17	<p>What is the maximum number of voice channels available per RF channel that can be supported at one BS with 1 RF channel (TDD systems) or 1 duplex RF channel pair (FDD systems), while still meeting ITU-T Recommendation G.726 [44] performance requirements?</p> <p>Answer: Up to 256 orthogonal codes are available for each downlink scrambling code, per sub-beam. Reserving three codes for the CCPCs and the acquisition aid pilot, up to a maximum of 253 channels is available per sub-beam, plus 256 channelization code per secondary scrambling code. See system description for detailed capacity evaluation.</p> <p>NOTE 8: A sub-beam is here defined as a single RF frequency channel associated to a single satellite spot, i.e. it is the intersection of a satellite spot beam and an RF channel.</p>

A1.2.18	<p><i>Variable bit rate capabilities:</i> describe the ways the proposal is able to handle variable baseband transmission rates. For example, does the RTT use:</p> <ul style="list-style-type: none"> - adaptive source and channel coding as a function of RF signal quality? - Variable data rate as a function of user application? - Variable voice/data channel utilization as a function of traffic mix requirements? <p>Characterize how the bit rate modification is performed. In addition, what are the advantages of your system proposal associated with variable bit rate capabilities?</p> <p>Answer: Source coding is not part of this RTT.</p> <ul style="list-style-type: none"> - For speech, Adaptive Multi-Rate (AMR) technique can be used every 20 ms speech frame to adapt air interface loading and speech connections quality. - Different frame format and data rates can be specified via the Transport Format Control Indicator (TFCI) associated to each transmitted data frame. Different channel coding parameters can also be associated to the different frame formats (see System Description). However, variation of the frame format and data rate has to be managed at higher protocol layer (MAC layer) than the physical layer. - Orthogonal Variable Spreading Factor (OVSF) codes are used to adapt the channel bit rate to the user requirements. Moreover, data rate can change on a frame by frame basis without any specific rate negotiation between the two communication entities thanks to a Transport Format Combination Indicator (TFCI) associated to each channel or thanks to Blink Detection. - Multiple spreading codes can be assigned for user information bit rates exceeding 384 Kbit/s.
A1.2.18.1	<p>What are the user information bit rates in each variable bit rate mode?</p> <p>Answer: See system description.</p>
A1.2.19	<p>What kind of voice coding scheme or codec is assumed to be used in the proposed RTT? If the existing specific voice coding scheme or codec is to be used, give the name of it. If a special voice coding scheme or codec (e.g. those not standardized in standardization bodies such as ITU) is indispensable for the proposed RTT, provide detail, e.g. scheme, algorithm, coding rates, coding delays and the number of stochastic code-books.</p> <p>Answer: This RTT does not envisage any specific voice coding technique. Different voice coding techniques can be supported, including AMR.</p>
A1.2.19.1	<p>Does the proposal offer multiple voice coding rate capability? Provide detail.</p> <p>Answer: This RTT provide multiple bit rate capability that will allow fitting multiple voice coding standards like G.729, G.723.1, GSM (full and half rate), IS-54, IS-96. Also, it will support voice activation (DTX) and AMR.</p>
A1.2.20	<p><i>Data services:</i> are there particular aspects of the proposed technologies which are applicable for the provision of circuit-switched, packet-switched or other data services like asymmetric data services? For each service class (A, B, C and D) a description of RTT services should be provided, at least in terms of bit rate, delay and BER/frame error rate (FER).</p> <p>NOTE 9: See ITU-R Recommendation M.1224 [45] for the definition of:</p> <ul style="list-style-type: none"> - "circuit transfer mode"; - "packet transfer mode"; - "connectionless service"; and - for the aid of understanding "circuit switched"; and - "packet switched" data services. <p>Answer: The proposed RTT is able to provide all type of services: circuit-switched and packet switched for both the connection oriented and connectionless protocols. Bearer services with different BER and delay requirements can be set up thanks to the possibility of specifying different coding strategies and different interleaving depth.</p>
A1.2.20.1	<p>For delay constrained, connection oriented (Class A).</p> <p>Answer: All bit rates in the range 2,4 Kbit/s to 384 Kbit/s can be provided with BER <1.E-3, BLER <2 E-2. Lower BER options are also available and can be negotiated at call set-up. BER of 1E-6 or lower, however, requires Turbo Codes and the associated delay is compatible only with the higher bit rates (32 Kbit/s and more). Transmission delay is strongly dependent on the satellite constellation characteristics, which is not part of this RTT.</p>
A1.2.20.2	<p>For delay constrained, connection oriented, variable bit rate (Class B).</p> <p>Answer: Connection oriented, variable bit rate services are supported. In particular, very large flexibility in data rate has been introduced directly at the physical layer. BER/BLER performances and delay as in A1.2.20.1 can be achieved.</p>

A1.2.20.3	For delay unconstrained, connection oriented (Class C). Answer: As for the other service class, Quality of Service can be negotiated at call set-up. Lacking strict constraints on delay, concatenated coding schemes can be used with longer interleaving thus allowing to achieve BER lower than 10^{-6} independently from the user data rate.
A1.2.20.4	For delay unconstrained, connectionless (Class D). Answer: Connectionless services mapped on Dedicated Traffic Channels (DTCH) have the same Quality of Service of delay unconstrained, connection oriented service (see A1.20.3). Connectionless services mapped on Random Traffic Channel are limited to BER higher than 10^{-6} . However, further service specific coding can be used to achieve the required QoS.
A1.2.21	Simultaneous voice/data services: is the proposal capable of providing multiple user services simultaneously with appropriate channel capacity assignment? Answer: Simultaneous multiple user services is supported. The different services can have independent bit rate, BER, delay, etc. and can have different transfer modes (packet/circuit-switched).
A1.2.22	<i>Power control characteristics:</i> is a power control scheme included in the proposal? Characterize the impact (e.g. improvements) of supported power control schemes on system performance. Answer: Closed loop power control is implemented for both the forward and return link. The loop is driven in order to set the measured SIR to a target value. The target value is itself adaptively changed with an additional control loop based on BLER measurements. Due to satellite propagation delay, closed loop power control does not fight fast fading but improves slow fading correction. An open loop power control is also active for packet transmission and initial setting of power during call set-up phase.
A1.2.22.1	What is the power control step size (dB)? Answer: A multilevel power control is utilized. Step size can be chosen in the range 1 dB to 3 dB
A1.2.22.2	What is the number of power control cycles per second? Answer: There are 1 500 power control cycles per second for both UL and DL.
A1.2.22.3	What is the power control dynamic range (dB)? Answer: For portable terminals, the power control dynamic range is 20 dB.
A1.2.22.4	What is the minimum transmit power level with power control? Answer: It depends on the space segment characteristics that are not covered by this proposal. For a portable terminal with 33 dBm maximum transmit power and 20 dB power control dynamic range, the corresponding minimum transmit power is 13 dBm.
A1.2.22.5	What is the residual power variation after power control when RTT is operating? Provide details about the circumstances (e.g. in terms of system characteristics, environment, deployment, MS-speed, etc.) under which this residual power variation appears and which impact it has on the system performance. Answer: Power control only tracks the low frequency variation of channel attenuation and compensate for the geographic (slant range and position in the beam) effects on the signal SNR. Further it is the responsibility of the power control loop to adaptively set the required SNR according to the target BLER.
A1.2.23	<i>Diversity combining in MS and BS:</i> are diversity combining schemes incorporated in the design of the RTT?

A1.2.23.1	<p>Describe the diversity techniques applied in the MS and at the BS, including micro diversity and macro diversity, characterizing the type of diversity used, for example:</p> <ul style="list-style-type: none"> - time diversity: repetition, Rake-receiver, etc.; - space diversity: multiple sectors, multiple satellite, etc.; - frequency diversity: FH, wide-band transmission, etc.; - code diversity: multiple PN codes, multiple FH code, etc.; - other scheme. <p>Characterize the diversity combining algorithm, for example, switch diversity, maximal ratio combining, equal gain combining. Additionally, provide supporting values for the number of receivers (or demodulators) per cell per mobile user. State the dB of performance improvement introduced by the use of diversity.</p> <p>For the MS: what is the minimum number of RF receivers (or demodulators) per mobile unit and what is the minimum number of antennas per mobile unit required for the purpose of diversity reception?</p> <p>These numbers should be consistent to that assumed in the link budget template of annex C and that assumed in the calculation of the "capacity" defined at section A.1.3.1.5.</p> <p>Answer: The RTT supports space diversity and time diversity respectively through the use of multiple satellite and channel coding/interleaving.</p> <p>Maximal ratio combining is supported on both the forward and reverse link.</p> <p>Up to Six fingers can be required in the LES depending on the satellite constellation. On the reverse link, in fact, there is a clear advantage in trying to combine the UE signal travelling through all satellites in visibility and/or adjacent beams of the same satellite. The combining of the UE signal at the LES on the reverse link is transparent to the UE and no resources have to be explicitly allocated.</p> <p>On the forward link, satellite diversity requires the explicit transmission from the LES on the different satellites in visibility with the user. To this end, the UE has to inform the LES of the quality with which each satellite is received. The LES will then decide if to allocate additional satellites to the pool of resources used by the UE and inform the UE to add a new finger. A single MS antenna per mobile unit is foreseen.</p> <p>For a single GSO satellite configuration, in case of IMR deployments, a minimum of three fingers is required per UE</p>
A1.2.23.2	<p>What is the degree of improvement expected (dB)? Also indicate the assumed conditions such as BLER and FER.</p> <p>Answer: FFS</p>

A1.2.24	<p><i>Handover/automatic radio link transfer (ALT)</i>: do the radio transmission technologies support handover? Characterize the type of handover strategy (or strategies) which may be supported, e.g. MS assisted handover. Give explanations on potential advantages, e.g. possible choice of handover algorithms. Provide evidence whenever possible.</p> <p>Answer: The handover strategy is Mobile Assisted Network Initiated Soft Handover (MANISH). Soft and softer handover is supported. The following handoff types are the most common in the system.</p> <p>Beam hand-off The UE always measures the level of the pilot $C / (N + I)$ coming from adjacent beams and report such information to the LES. The LES may then decide to transmit the same channel through two different beams (soft beam hand-off) and command the UE to add a finger to demodulate the additional signal. As soon as the LES receives a confirmation that the new signal is received, it drops the old connection. There is in fact no scope to have a prolonged inter-beam soft handoff because no path diversity is actually introduced.</p> <p>Inter-satellite handoff The procedure is analogous to that of inter-beam hand-off. The only difference is that the UE has also to search for different satellite specific pilot scrambling codes. If a new, strong enough, pilot scrambling code is detected, the measure is reported back to the LES, which may decide to exploit satellite diversity by transmitting the same signal through different satellites. Differently from the previous case, there is now a path diversity advantage and it is useful that all strong enough diversity paths are exploited. Maximal ratio combining can then be performed (time ambiguity resolution is done through the primary CCPCHs MF synchronization).</p> <p>Inter-frequency handoff Only hard inter-frequency, handoff is supported. This hand-off can be either intra-gateway or inter-gateway. Inter-frequency handoff is generally not needed. This hand-off is decided by the LES without any support by the UE (i.e. this hand-off type is not a mobile-assisted handoff). On the reverse link, the LES will instead combine all signals received from the same UE through different beams and / or satellites.</p>
A1.2.24.1	<p>What is the break duration (s) when a handover is executed? In this evaluation, a detailed description of the impact of the handover on the service performance should also be given. Explain how the estimate was derived.</p> <p>Answer: Soft handover has no break time.</p>
A1.2.24.2	<p>For the proposed RTT, can handover cope with rapid decrease in signal strength (e.g. street corner effect)? Give a detailed description of:</p> <ul style="list-style-type: none"> - the way the handover detected, initiated and executed; - how long each of this action lasts (minimum/maximum time (ms)); - the time-out periods for these actions. <p>Answer: Multiple satellites diversity will minimize the outage probability due to the Line of Sight (LOS) blockage (or heavy shadow). On the reverse link all visible satellites can be exploited to increase the overall link quality provided that the LES can allocate a finger for each satellite in visibility. On the forward link, limitation in the number of available fingers in the UE receiver and the fact that explicit resources have to be allocated, can limit the number of satellites used for diversity to a value not larger than six. Although diversity on the forward link can actually reduce the normalized power and bandwidth efficiency (according to the evaluation procedure suggested in ITU-R Recommendation M.1225 [1] annex 2), it is believed that only satellite diversity can provide an acceptable outage probability in land mobile application without imposing the use of too large link margins to counteract deep shadowing. See A1.2.24 for a description of handover detection and execution. Because of the soft handover characteristic, there is no specific time out.</p>

A1.2.25	<p>Characterize how the proposed RTT reacts to the system deployment (e.g. necessity to add new cells and/or new carriers) particularly in terms of frequency planning.</p> <p>Answer: This RTT supports full frequency reuse (frequency reuse factor equal to 1). Hence no ad-hoc planning is required to, for example, enlarge the satellite constellation and or increase the frequency band utilized apart for the normal co-ordination procedure with the other systems</p>
A1.2.26	<p><i>Sharing frequency band capabilities:</i> to what degree is the proposal able to deal with spectrum sharing among IMT-2000 systems as well as with all other systems:</p> <ul style="list-style-type: none"> - spectrum sharing between operators; - spectrum sharing between terrestrial and satellite IMT-2000 systems; - spectrum sharing between IMT-2000 and non-IMT-2000 systems; - other sharing schemes. <p>Answer: Use of a spread spectrum transmission technique actually simplifies band sharing between different operators. Spread spectrum techniques will in fact significantly reduce the requirement for Adjacent Channel Protection that may instead penalize other access techniques. Spectrum sharing between terrestrial and satellite IMT-2000 systems has not been specifically considered in this proposal. However, its feasibility is not unreasonable if the access scheme of the two components is consistent.</p>
A1.2.27	<p><i>Dynamic channel allocation:</i> characterize the dynamic channel allocation (DCA) schemes which may be supported and characterize their impact on system performance (e.g. in terms of adaptability to varying interference conditions, adaptability to varying traffic conditions, capability to avoid frequency planning, impact on the reuse distance, etc.).</p> <p>Answer: No DCA strategy is required.</p>
A1.2.28	<p>Mixed cell architecture: How well do the technologies accommodate mixed cell architectures (pico, micro and macro-cells)? Does the proposal provide pico, micro and macro cell user service in a single licensed spectrum assignment, with handoff as required between them? (terrestrial component only)</p> <p>NOTE 10: Cell definitions are as follows:</p> <ul style="list-style-type: none"> Pico - cell hex radius (r) < 100 m Micro - 100 m < (r) < 1 000 m Pico - (r) > 1 000 m <p>Answer: This RTT focuses on satellite component. Possibility of global beam + multi-beam. In case of use of IMRs, mixed cell architecture is accommodated. Then pico/micro/macro and satellite cell services are assigned to the same frequency carrier. Seamless handover is possible between the cell layers.</p>
A1.2.29	<p>Describe any battery saver/intermittent reception capability.</p> <p>Answer: During circuit switched operation the transmitter is continuously on, but power control, transmission agility and discontinuous transmission (e.g.: voice activity detection) allow to minimize the required RF power of the UE terminals. With packet traffic, depending on the packet-access mode, the receiver and the transmitter can be used periodical, i.e. switched off until data is available for transmission.</p>
A1.2.29.1	<p><i>Ability of the MS to conserve standby battery power:</i> provide details about how the proposal conserves standby battery power.</p> <p>Answer: In stand-by the receiver will only listen to the broadcast and paging channels, periodically searching new pilot signals. This is slotted reception, UEs are powered-on only in time to receive the assigned slot for any possible pages or messages.</p>
A1.2.30	<p><i>Signalling transmission scheme:</i> if the proposed system will use RTTs for signalling transmission different from those for user data transmission, describe the details of the signalling transmission scheme over the radio interface between terminals and base (satellite) stations.</p> <p>Answer: for layers above layer 2, the proposed system will use for signalling the same RTT as for data transmission: user data and signalling is time multiplexed on Layer 1. Layer 1 signalling (transmit power control command, rate indication) will use a control channel (DPCCH) associated to each data channel.</p>

A1.2.30.1	Describe the different signalling transfer schemes which may be supported, e.g. in connection with a call, outside a call. Does the RTT support: - new techniques? Characterize. - Signalling enhancements for the delivery of multimedia services? Characterize. Answer: Because signalling uses the same RTT as the user data, the system is open to any signalling technique. Signalling can be multiplexed with data on a unique physical channel. Special features, like rate indication, are however specifically supported by the physical layer to better cope with variable rate services, like multimedia services.
A1.2.31	Does the RTT support a bandwidth on demand (BOD) capability? BOD refers specifically to the ability of an end-user to request multi-bearer services. Typically, this is given as the capacity in the form of bits per second of throughput. Multi-bearer services can be implemented by using such technologies as multi-carrier, multi-time slot or multi-codes. If so, characterize these capabilities. NOTE 11: BOD does not refer to the self-adaptive feature of the radio channel to cope with changes in the transmission quality (see section A1.2.5.1). Answer: Multiple bearer services are available in the proposed system. Bit rate may vary from 2,4 bit/s up to 384 Kbit/s. The BOD possibility is implemented by multiplexing the multi-bearer traffic on a single L1 traffic stream to be carried by the variable rate physical channel (for higher rates, combination of variable spreading factor and multi-code transmission).
A1.2.32	Does the RTT support channel aggregation capability to achieve higher user bit rates? Answer: Channel aggregation (i.e. multiple codes) can be used to achieve higher bit rates (up to 2 Mbps).

E.3 Expected performances

A1.3	Expected performances.
A1.3.2	For satellite test environment only.
A1.3.2.1	What is the required C/N_0 to achieve objective performance defined in annex C? Answer: Results are dependent on the satellite characteristics and constellation characteristics. The results assume a GEO constellation (36 000 Km height) with satellites having 30 beams. Only one satellites is visible from any given point. See Link Budget examples.
A1.3.2.2	What are the Doppler compensation method and residual Doppler shift after compensation? Answer: With a GEO constellation, Doppler shift due to the satellite movement is 22 Hz in the Core Band, 27 Hz in the Extension Band. This is negligible to be compared to Doppler shift due to UE motion. For the Doppler shift due to UE velocity, in aeronautical environment (max UE speed: 5 000 km/h) an additional Doppler shift of up to 10 185 Hz in the Core Band, and 12 450 Hz in the Extension Band is to be compensated. Compensation methods are similar to the ones for 3G standardized terrestrial products for UE speeds up to 500 km/h. An adaptation is to be implemented for aeronautical environment (UE speed up to 5 000 km/h).
A1.3.2.3	<i>Capacity:</i> the spectrum efficiency of the radio transmission technology has to be evaluated assuming the deployment models described in annex C.
A1.3.2.3.1	What is the voice information capacity per required RF bandwidth (bit/s/Hz)? Answer: Results are dependent on the constellation and satellite characteristics. Also a trade-off is possible between power and bandwidth efficiency. See system description.
A1.3.2.3.2	What is the voice plus data information capacity per required RF bandwidth (bit/s/Hz)? Answer: Results are dependent on the constellation and satellite characteristics. Also a trade-off is possible between power and bandwidth efficiency. See system description.

A1.3.2.4	<p><i>Normalized power efficiency</i>: the power efficiency of the radio transmission technology has to be evaluated assuming the deployment models described in annex C. What is the supported information bit rate per required carrier power-to-noise density ratio for the given channel performance under the given interference conditions for voice?</p> <p>Answer: Results are dependent on the satellite characteristics and constellation characteristics. See system description.</p>
A1.3.2.4.2	<p>What is the supported information bit rate per required carrier power-to-noise density ratio for the given channel performance under the given interference conditions for voice plus data?</p> <p>Answer: See system description.</p>
A1.3.3	<p><i>Maximum user bit rate (for data)</i>: specify the maximum user bit rate (kbit/s) available in the deployment models described in annex C.</p> <p>Answer: 384 Kbit/s (multi-beam);</p>
A1.3.4	<p>What is the maximum range (m) between a user terminal and a BS (prior to hand-off, relay, etc.) under nominal traffic loading and link impairments as defined in annex C?</p> <p>Answer: the maximum range is constellation dependent (ex: GEO = $\sim 2 \times 36\,000$ km). See example for GEO in link budgets.</p>
A1.3.5	<p>Describe the capability for the use of repeaters.</p> <p>Answer: see system description.</p>
A1.3.6	<p><i>Antenna systems</i>: fully describe the antenna systems that can be used and/or have to be used; characterize their impacts on systems performance, (terrestrial only); e.g. does the RTT have the capability for the use of:</p> <ul style="list-style-type: none"> - remote antennas: describe whether and how remote antenna systems can be used to extend coverage to low traffic density areas; - distributed antennas: describe whether and how distributed antenna designs are used, and in which IMT-2000 test environments; - Smart antennas (e.g. switched beam, adaptive, etc.): describe how smart antennas can be used and what is their impact on system performance; - other antenna systems. <p>Answer: See Link Budget examples and textual description.</p>
A1.3.7	<p>Delay (for voice)</p> <p>Answer: The delay will depend mainly on the selected satellite constellation characteristics and on the source coding technique. The delay introduced by the radio part is typically 20 ms. (with 20 ms. interleaving depth). In case of GEO constellation the delay introduced by the transmission path is up to 250 ms.</p>
A1.3.7.1	<p>What is the radio transmission processing delay due to the overall process of channel coding, bit interleaving, framing, etc., not including source coding? This is given as transmitter delay from the input of the channel coder to the antenna plus the receiver delay from the antenna to the output of the channel decoder. Provide this information for each service being provided. In addition, a detailed description of how this parameter was calculated is required for both the uplink and the downlink.</p> <p>Answer: It depends on the selected interleaving depth. Minimum interleaving depth is one frame (10 ms). Maximum interleaving depth is 8 frames (80 ms). With a 1/3 FEC, the processing delay is $3 \times 80 = 240$ ms.</p>
A1.3.7.2	<p>What is the total estimated round trip delay (ms) to include both the processing delay, propagation delay (terrestrial only) and vocoder delay? Give the estimated delay associated with each of the key attributes described in Figure 6 that make up the total delay provided.</p> <p>Answer: Source coding is not included in this RTT. Source coding which may find use with this RTT like G729, IS-96 QCELP and G723.1 have total delay respectively of 25 ms, 45 ms and 67,5 ms. Interleaving delay are given in A1.3.7.1. Propagation delay is satellite constellation dependent.</p>
A1.3.7.3	<p>Does the proposed RTT need echo control?</p> <p>Answer: Yes.</p>

A1.3.8	<p>What is the MOS level for the proposed codec for the relevant test environments given in annex C? Specify its absolute MOS value and its relative value with respect to the MOS value of ITU-T Recommendation G.711 [46] (64 k PCM) and ITU-T Recommendation G.726 [44] (32 k ADPCM).</p> <p>NOTE: If a special voice coding algorithm is indispensable for the proposed RTT, the proponent should declare detail with its performance of the codec such as MOS level. (See section A1.2.19)</p> <p>Answer: Speech coding is not part of this proposal.</p>
A1.3.9	Description of the ability to sustain quality under certain extreme conditions.
A1.3.9.2	<p><i>Hardware failures:</i> characterize system behaviour and performance in such conditions. Provide detailed explanation on any calculation.</p> <p>Answer: System behaviour is implementation dependent. The possibility to exploit satellite diversity makes the system less sensitive to isolated faults in one satellite.</p>
A1.3.9.3	<p><i>Interference immunity:</i> characterize system immunity or protection mechanisms against interference. What is the interference detection method? What is the interference avoidance method?</p> <p>Answer: The system is inherently robust against interference thanks to the CDMA access. Further, the proposed RTT support interference mitigation techniques like linear Multi-User Detection (MUD) receiver which may be optionally exploited to reduce interference.</p>
A1.3.10	<p>Characterize the adaptability of the proposed RTT to different and/or time-varying conditions (e.g. propagation, traffic, etc.) that are not considered in the above attributes of section A1.3.</p> <p>Answer: Power control is utilized to decrease the amount of self-interference. Furthermore, the RTT is designed to incorporate linear MUD interference mitigation at the LES.</p>

E.4 Technology design constraints

A1.4	Technology design constraints.
A1.4.1	<i>Frequency stability:</i> provide transmission frequency stability (not oscillator stability) requirements of the carrier (include long term - 1 year - frequency stability requirements (ppm)).
A1.4.1.2	<p>For MS transmission.</p> <p>Answer: $\pm 0,1$ ppm over 1 time slot compared to the carrier frequency received from the Node B (assuming UE is frequency synchronized to the downlink).</p>
A1.4.2	<p><i>Out-of-band and spurious emissions:</i> specify the expected levels of base or satellite and mobile transmitter emissions outside the operating channel, as a function of frequency offset.</p> <p>Answer:</p> <p>UE:</p> <p>Outside the band 1 980 MHz to 2 010 MHz: $\Delta f = 0$ kHz to 166 kHz $\rightarrow 0 - (\Delta f \times 55 / 166)$ dBW $\Delta f = 166$ kHz to 575 kHz $\rightarrow -55$ Dbw $\Delta f = 575$ kHz to 1 175 kHz $\rightarrow -60$ dBW $\Delta f = 1 175$ kHz to 1 525 kHz $\rightarrow -60 - ((\Delta f - 1 175) \times 5 / 350)$ dBW $\Delta f = 1 525$ kHz to 32 000 kHz $\rightarrow -70$ dBW</p> <p>Satellite: see satellite transmission mask</p>

A1.4.3	<p><i>Synchronization requirements:</i> describe RTT's timing requirements, e.g.:</p> <ul style="list-style-type: none"> - Is BS-to-BS or satellite land earth station (LES)-to-LES synchronization required? Provide precise information, the type of synchronization, i.e. synchronization of carrier frequency, bit clock, spreading code or frame, and their accuracy. <p>Answer: No synchronization required apart for a time accuracy in the order of 10 ms to ease soft handoff procedures.</p> <ul style="list-style-type: none"> - State short-term frequency and timing accuracy of BS (or LES) transmit signal. <p>Answer: Frequency accuracy within $\pm 0,05$ ppm over one time slot period. Timing accuracy: TBC.</p> <ul style="list-style-type: none"> - State source of external system reference and the accuracy required, if used at BS (or LES) (for example: derived from wireline network, or GPS receiver). <p>Answer: A reference clock can be derived from the RNC or from GPS.</p> <ul style="list-style-type: none"> - State free run accuracy of MS frequency and timing reference clock. <p>Answer: Short term accuracy: $\pm 0,1$ ppm over 1 time slot period.</p> <ul style="list-style-type: none"> - State base-to-base bit time alignment requirement over a 24 h period (ms). <p>Answer: A specific requirement is needed only if inter-LES handover has to be supported. In that case 10 ms of time accuracy is sufficient.</p> <p><i>TBC (cf Iub synchronization, etc)</i></p>
A1.4.4	<p><i>Timing jitter:</i> for BS (or LES) and MS give:</p> <ul style="list-style-type: none"> - the maximum jitter on the transmit signal; - the maximum jitter tolerated on the received signal. <p>Timing jitter is defined as r.m.s. value of the time variance normalized by symbol duration.</p> <p>Answer: It is expected that timing jitter less than 3 % of the chip duration will not produce any significant signal degradation.</p>
A1.4.5	<p><i>Frequency synthesizer:</i> what is the required step size, switched speed and frequency range of the frequency synthesizer of MSs?</p> <p>Answer:</p> <ul style="list-style-type: none"> - Step size: 200 kHz - Switched speed: No strict requirement (< 10 ms). - Frequency range: 220 MHz (for MSS bandwidth).
A1.4.6	<p>Does the proposed system require capabilities of fixed networks not generally available today?</p> <p>Answer: No</p>
A1.4.6.1	<p>Describe the special requirements on the fixed networks for the handover procedure. Provide handover procedure to be employed in proposed RTT in detail.</p> <p>Answer: No special requirement on the fixed network is required.</p>
A1.4.7	<p>Fixed network feature transparency.</p>
A1.4.7.1	<p>Which service(s) of the standard set of ISDN bearer services can the proposed RTT pass to users without fixed network modification.</p> <p>Answer: 64 Kbit/s bearer services are supported. Extension to 384 Kbit/s is also feasible.</p>
A1.4.8	<p>Characterize any radio resource control capabilities that exist for the provision of roaming between a private (e.g. closed user group) and a public IMT-2000 operating environment.</p> <p>Answer: This RTT proposal only address physical layer issues. Higher layer signalling is required for that purpose.</p>

A1.4.9	<p>Describe the estimated fixed signalling overhead (e.g. broadcast control channel, power control messaging). Express this information as a percentage of the spectrum which is used for fixed signalling. Provide detailed explanation on your calculations.</p> <p>Answer: <u>Down-link:</u> Pilot channel (CPICH) SCH For each downlink spot beam a pilot channel and a broadcast channel are needed. Channel data rate on the primary CCPCH (broadcast channel bringing system specific information) is 30. A secondary CCPCH may also be active. These three channels consume 2 channelization codes out of 256 available. Power control commands and frame control header bit contribute 250 bit/s or 500 bit/s per traffic channel whilst reference symbols are optional. These bits are time multiplexed with the data channel (DPDCH) and due to the particular coding adopted, they consume 10 % of the whole frame period. However, the associated power may be lower or higher than the power associated to the data channel depending on the data rate The power overhead is between 1 % and 15 % according to the channel data rate. Use of the optional reference symbols will double the above overhead.</p> <p><u>Up-link:</u> Power control commands, frame control header bit and reference symbols are multiplexed in a control channel transmitted in phase quadrature with the associated traffic channel. The control channel has fixed channel data rate (15 kbps). Its power is however significantly lower than the power allocated to the traffic channel (from less than 10 % to 50 % for low data rate).</p>
A1.4.13	<p>What are the signal processing estimates for both the hand-portable and the BS?</p> <ul style="list-style-type: none"> - MOPS (millions of operations per second) value of parts processed by DSP (digital signal processing); - gate counts excluding DSP; - ROM size requirements for DSP and gate counts (kbytes); - RAM size requirements for DSP and gate counts (kbytes). <p>NOTE 1: At a minimum the evaluation should review the signal processing estimates (MOPS, memory requirements, gate counts) required for demodulation, equalization, channel coding, error correction, diversity processing (including Rake receivers), adaptive antenna array processing, modulation, A-D and D-A converters and multiplexing as well as some IF and baseband filtering. For new technologies, there may be additional or alternative requirements (such as FFTs etc.).</p> <p>NOTE 2: The signal processing estimates should be declared with the estimated condition such as assumed services, user bit rate and etc.</p> <p>Answer: Evaluation is underway</p>
A1.4.14	<p><i>Dropped calls:</i> describe how the RTT handles dropped calls. Does the proposed RTT utilize a transparent reconnect procedure - that is, the same as that employed for handoff?</p> <p>Answer: This RTT proposal supports the transparent reconnect procedure.</p>
A1.4.15	<p>Characterize the frequency planning requirements:</p> <ul style="list-style-type: none"> - frequency reuse pattern: given the required C/I and the proposed technologies, specify the frequency cell reuse pattern (e.g. 3-cell, 7-cell, etc.) and, for terrestrial systems, the sectorization schemes assumed; - Characterize the frequency management between different cell layers; - does the RTT use an interleaved frequency plan? - are there any frequency channels with particular planning requirements? - all other relevant requirements. <p>NOTE 3: The use of the second adjacent channel instead of the adjacent channel at a neighbouring cluster cell is called "interleaved frequency planning". If a proponent is going to employ an interleaved frequency plan, the proponent should state so in section A1.2.4 and complete section A1.2.15 with the protection ratio for both the adjacent and second adjacent channel.</p> <p>Answer:</p> <ul style="list-style-type: none"> - Full frequency reuse is supported. - There are not multiple cell layers within the satellite segment. - There is no need for interleaved frequency plan nor frequency channel with particular planning requirements

A1.4.16	<p>Describe the capability of the proposed RTT to facilitate the evolution of existing radio transmission technologies used in mobile telecommunication systems migrate toward this RTT. Provide detail any impact and constraint on evolution.</p> <p>Answer: The proposed RTT has been designed to simplify the implementation of dual-mode terminals (terrestrial - satellite UMTS). In particular, the most relevant radio parameters, modulation, spreading and scrambling have been designed to have the maximum commonality with the 3GPP W-CDMA proposal for the terrestrial IMT-2000 environments.</p>
---------	--

E.5 Information required for terrestrial link budget template

Not applicable.

See IMRs -> link budgets with IMR Eb/Nt

E.6 Satellite system configuration

A1.6	<p><i>Satellite system configuration</i> (applicable to satellite component only): Configuration details in this clause are not to be considered as variables. They are for information only.</p>
A1.6.1	<p>Configuration of satellite constellation</p>
A1.6.1.1	<p>GSO, HEO, MEO, LEO or combination?</p> <p>Answer: The proposed RTT has not been designed specifically for a satellite constellation. It can be used with all type, or combination, of constellations. Constellations providing multi-satellite visibility will however better exploit the capability of the proposed RTT to take advantage of satellite diversity for minimizing the outage probability</p>
A1.6.1.2	<p>What is the range of height where satellites are in active communication?</p> <p>Answer: It depends on the constellation type which is not part of this proposal.</p>
A1.6.1.3	<p>What is the orbit inclination angle?</p> <p>Answer: It depends on the constellation type which is not part of this proposal.</p>
A1.6.1.4	<p>What are the number of orbit planes?</p> <p>Answer: It depends on the constellation type which is not part of this proposal.</p>
A1.6.1.5	<p>What are the number of satellites per orbit plane?</p> <p>Answer: It depends on the constellation type which is not part of this proposal.</p>
A1.6.2	<p>What is the configuration of spot beams/cell layout pattern?</p> <p>Answer: It is not defined by this RTT. The RTT proposal is however extremely flexible in this regard. In particular it also supports adaptive digital beam-forming configurations able to generate an independent beam per user. This feature may be particularly attractive for the downlink implementation, where implementation complexity issues are more manageable and where maximum power efficiency improvement is of paramount importance.</p>
A1.6.3	<p>What is the frequency reuse plan among spot beams?</p> <p>Answer: Full frequency reuse is supported.</p>
A1.6.4	<p>What is the service link G/T of satellite beam (average, minimum)?</p> <p>Answer: It depends on the constellation and satellite characteristics, which are not defined in this proposal. See example in the Link budget.</p>
A1.6.5	<p>What is the service link saturation E.I.R.P. of each beam (average, minimum), when configured to support "hot spot"?</p> <p>Answer: It depends on the satellite characteristics which are not defined in this proposal.</p>
A1.6.6	<p>What is the service link total saturation E.I.R.P. per satellite?</p> <p>Answer: It depends on the satellite characteristics which are not defined in this proposal.</p>
A1.6.7	<p>Satellite E.I.R.P. per RF carrier for satellite component.</p>
A1.6.7.1	<p>What is the maximum peak E.I.R.P. transmitted per RF carrier?</p> <p>Answer: It depends on the particular constellation and satellite beam configuration.</p>
A1.6.7.2	<p>What is the average E.I.R.P. transmitted per RF carrier?</p> <p>Answer: It depends on the particular constellation and satellite beam configuration. See example in the Link budget.</p>

A1.6.8	What is the feeder link information? Answer: Feeder link architecture is not constrained by the proposed RTT.
A1.6.9	What is the slot timing adjustment method (mainly applicable to TDMA system)? Answer: Not applicable for the proposed access.
A1.6.10	What is the satellite diversity method, if applicable? Answer: The proposed RTT support maximal ratio combining of all the signals coming from visible satellites on both forward and reverse links. In the reverse link same satellite beam diversity can also be exploited to further reduce the UE E.I.R.P. required to close the link.

History

Document history		
V1.1.1	November 2004	Publication