

**Electromagnetic compatibility
and Radio spectrum Matters (ERM);
Improvement on Radiated Methods
of Measurement (using test site) and evaluation
of the corresponding measurement uncertainties;
Part 3: Anechoic chamber with a ground plane**



Reference

RTR/ERM-RP02-057-3

Keywordsanalogue, data, measurement uncertainty,
mobile, radio, testing**ETSI**

650 Route des Lucioles
F-06921 Sophia Antipolis Cedex - FRANCE

Tel.: +33 4 92 94 42 00 Fax: +33 4 93 65 47 16

Siret N° 348 623 562 00017 - NAF 742 C
Association à but non lucratif enregistrée à la
Sous-Préfecture de Grasse (06) N° 7803/88

Important notice

Individual copies of the present document can be downloaded from:

<http://www.etsi.org>

The present document may be made available in more than one electronic version or in print. In any case of existing or perceived difference in contents between such versions, the reference version is the Portable Document Format (PDF). In case of dispute, the reference shall be the printing on ETSI printers of the PDF version kept on a specific network drive within ETSI Secretariat.

Users of the present document should be aware that the document may be subject to revision or change of status. Information on the current status of this and other ETSI documents is available at

<http://portal.etsi.org/tb/status/status.asp>

If you find errors in the present document, send your comment to:

editor@etsi.fr

Copyright Notification

No part may be reproduced except as authorized by written permission.
The copyright and the foregoing restriction extend to reproduction in all media.

© European Telecommunications Standards Institute 2001.
All rights reserved.

Contents

Intellectual Property Rights	6
Foreword.....	6
1 Scope	7
2 References	7
3 Definitions, symbols and abbreviations	8
3.1 Definitions	8
3.2 Symbols.....	12
3.3 Abbreviations	14
4 Introduction	15
5 Uncertainty contributions specific to an Anechoic Chamber with a Ground Plane	16
5.1 Effects of the metal shielding	16
5.1.1 Resonances	16
5.1.2 Imaging of antennas (or an EUT)	17
5.2 Effects of the radio absorbing materials	17
5.2.1 Introduction.....	17
5.2.2 Pyramidal absorbers.....	18
5.2.3 Wedge absorbers.....	19
5.2.4 Ferrite tiles	20
5.2.5 Ferrite grids.....	20
5.2.6 Urethane/ferrite hybrids	20
5.2.7 Performance comparison	21
5.2.8 Reflection in an Anechoic Chamber with a Ground Plane	22
5.2.9 Mutual coupling due to imaging in the absorbing material	24
5.2.10 Extraneous reflections.....	24
5.3 Effects of the ground plane.....	24
5.3.1 Reflections	24
5.3.2 Mutual coupling between antennas and in the ground plane	26
5.4 Other effects	30
5.4.1 Range length and measurement distance	30
5.4.2 Antenna mast, turntable and mounting fixtures	31
5.4.3 Test antenna height limitations	33
5.4.4 Test antenna cabling	34
5.4.5 EUT cabling.....	34
5.4.6 Positioning of the EUT and antennas.....	34
6 Verification procedure for an Anechoic Chamber with a Ground Plane	35
6.1 Introduction	35
6.2 Normalized site attenuation	36
6.2.1 Anechoic Chamber	36
6.2.2 Anechoic Chamber with a Ground Plane.....	38
6.2.3 Improvements to the formulae for E_{DH}^{\max} and E_{DV}^{\max}	40
6.2.4 Mutual coupling.....	42
6.3 Overview of the verification procedure.....	43
6.3.1 Apparatus required.....	45
6.3.2 Site preparation	45
6.3.3 Measurement configuration	46
6.3.4 What to record	47
6.4 Verification procedure.....	48
6.4.1 Procedure 1: 30 MHz to 1 000 MHz.....	48
6.4.2 Alternative procedure: 30 MHz to 1 000 MHz	53
6.4.3 Procedure 2: 1 GHz to 12,75 GHz	54
6.5 Processing the results of the verification procedure	58
6.5.1 Introduction.....	58

6.5.2	Procedure 1: 30 MHz to 1 000 MHz.....	59
6.5.3	Procedure 2: 1 GHz to 12,75 GHz.....	62
6.5.4	Report format.....	65
6.6	Calculation of measurement uncertainty (Procedure 1).....	65
6.6.1	Uncertainty contribution, direct attenuation measurement.....	65
6.6.2	Uncertainty contribution, NSA measurement.....	66
6.6.3	Expanded uncertainty of the verification procedure.....	67
6.7	Calculation of measurement uncertainty (Procedure 2).....	68
6.7.1	Uncertainty contribution, direct attenuation measurement.....	68
6.7.2	Uncertainty contribution, NSA measurement.....	69
6.7.3	Expanded uncertainty of the verification procedure.....	70
6.8	Summary.....	70
7	Test methods.....	71
7.1	Introduction.....	71
7.1.1	Site preparation.....	71
7.1.2	Preparation of the EUT.....	72
7.1.3	Standard antennas.....	73
7.1.4	Mutual coupling and mismatch loss correction factors.....	73
7.1.5	Power supplies to the EUT.....	73
7.1.6	Restrictions.....	73
7.2	Transmitter tests.....	74
7.2.1	Frequency error (30 MHz to 1 000 MHz).....	74
7.2.1.1	Apparatus required.....	74
7.2.1.2	Method of measurement.....	74
7.2.1.3	Procedure for completion of the overall results sheet.....	75
7.2.1.4	Log book entries.....	76
7.2.1.5	Statement of results.....	76
7.2.2	Expanded uncertainty for Frequency error test.....	76
7.2.3	Effective radiated power (30 MHz to 1 000 MHz).....	77
7.2.3.1	Apparatus required.....	77
7.2.3.2	Method of measurement.....	78
7.2.3.3	Procedure for completion of the overall results sheet.....	80
7.2.3.4	Log book entries.....	82
7.2.3.5	Statement of results.....	83
7.2.4	Measurement uncertainty for Effective radiated power.....	83
7.2.4.1	Uncertainty contributions: Stage one: EUT measurement.....	83
7.2.4.2	Uncertainty contributions: Stage 2: Substitution measurement.....	85
7.2.4.3	Expanded uncertainty of the ERP measurement.....	86
7.2.5	Spurious emissions (30 MHz to 4 Ghz or 12,75 GHz).....	86
7.2.5.1	Apparatus required.....	86
7.2.5.2	Method of measurement.....	87
7.2.5.3	Procedure for completion of the results sheets.....	92
7.2.5.4	Log book entries.....	94
7.2.5.5	Statement of results.....	96
7.2.6	Measurement uncertainty for Spurious emissions.....	96
7.2.6.1	Uncertainty contributions: Stage 1: EUT measurement.....	96
7.2.6.2	Uncertainty contributions: Stage 2: Substitution measurement.....	97
7.2.6.3	Expanded uncertainty of the Spurious emission.....	98
7.2.7	Adjacent channel power.....	98
7.3	Receiver tests.....	99
7.3.1	Sensitivity tests (30 MHz to 1 000 MHz).....	99
7.3.1.1	Apparatus required.....	100
7.3.1.2	Method of measurement.....	100
7.3.1.3	Procedure for completion of the overall results sheet.....	105
7.3.1.4	Log book entries.....	106
7.3.1.5	Statement of results.....	108
7.3.2	Measurement uncertainty for Receiver sensitivity.....	109
7.3.2.1	Uncertainty contributions: Stage one: Determination of transform factor.....	109
7.3.2.2	Uncertainty contributions: Stage 2: EUT measurement.....	110
7.3.2.3	Expanded uncertainty of the receiver sensitivity measurement.....	111
7.3.3	Co-channel rejection.....	111

7.3.4	Adjacent channel selectivity	111
7.3.5	Intermodulation immunity	111
7.3.6	Blocking immunity in desensitization.....	112
7.3.7	Spurious response immunity to radiated fields	112
Annex A:	Bibliography	113
History		115

Intellectual Property Rights

IPRs essential or potentially essential to the present document may have been declared to ETSI. The information pertaining to these essential IPRs, if any, is publicly available for **ETSI members and non-members**, and can be found in ETSI SR 000 314: "*Intellectual Property Rights (IPRs); Essential, or potentially Essential, IPRs notified to ETSI in respect of ETSI standards*", which is available from the ETSI Secretariat. Latest updates are available on the ETSI Web server (<http://webapp.etsi.org/IPR/home.asp>).

Pursuant to the ETSI IPR Policy, no investigation, including IPR searches, has been carried out by ETSI. No guarantee can be given as to the existence of other IPRs not referenced in ETSI SR 000 314 (or the updates on the ETSI Web server) which are, or may be, or may become, essential to the present document.

Foreword

This Technical Report (TR) has been produced by ETSI Technical Committee Electromagnetic compatibility and Radio spectrum Matters (ERM).

The present document is part 3 of a multi-part deliverable covering Improvement on radiated methods of measurement (using test site) and evaluation of the corresponding measurement uncertainties, as identified below:

Part 1: "Uncertainties in the measurement of mobile radio equipment characteristics";

Sub-part 1: "Introduction";

Sub-part 2: "Examples and annexes";

Part 2: "Anechoic chamber";

Part 3: "Anechoic chamber with a ground plane";

Part 4: "Open area test site";

Part 5: "Striplines";

Part 6: "Test Fixtures";

Part 7: "Artificial human beings".

1 Scope

The present document provides background to the subject of measurement uncertainty and proposes extensions and improvements relevant to radiated measurements. It also details the methods of radiated measurements (test methods for mobile radio equipment parameters and verification procedures for test sites) and additionally provides the methods for evaluating the associated measurement uncertainties.

The present document provides a method to be used together with all the applicable standards and (E)TRs, supports TR 100 027 [13] and can be used with TR 100 028 [12].

The present document covers the test methods for performing radiated measurements on mobile radio equipment in an Anechoic Chamber with a Ground Plane and also provides the methods for evaluation and calculation of the measurement uncertainties for each of the measured parameters.

2 References

For the purposes of this Technical Report (TR), the following references apply:

- [1] ANSI C63.5 (1998): "American National Standard for Calibration of Antennas Used for Radiated Emission Measurements in Electromagnetic Interference (EMI) Control Calibration of Antennas (9 kHz to 40 GHz)".
- [2] "Antenna Theory: Analysis and Design", 2nd Edition, Constantine A. Balanis (1996).
- [3] "Calculation of site attenuation from antenna factors", A. A. Smith Jr, RF German and J B Pate. IEEE transactions EMC. Vol. EMC 24 pp 301-316 Aug 1982.
- [4] ITU-T Recommendation O.41: "Psophometer for use on telephone-type circuits".
- [5] ITU-T Recommendation O.153: "Basic parameters for the measurement of error performance at bit rates below the primary rate".
- [6] CISPR 16-1: "Specification for radio disturbance and immunity measuring apparatus and methods - Part 1: Radio disturbance and immunity measuring apparatus".
- [7] EN 50147-2 (1996): "Anechoic chambers - Part 2: Alternative test site suitability with respect to site attenuation".
- [8] ETSI TR 102 273-1-1: "ElectroMagnetic Compatibility and Radio Spectrum Matters (ERM); Improvement on Radiated Methods of Measurement (using test site) and evaluation of the corresponding measurement uncertainties Part 1: Uncertainties in the measurement of mobile radio equipment characteristics; Sub-part 1: Introduction".
- [9] ETSI TR 102 273-1-2: "ElectroMagnetic Compatibility and Radio Spectrum Matters (ERM); Improvement on Radiated Methods of Measurement (using test site) and evaluation of the corresponding measurement uncertainties; Part 1: Uncertainties in the measurement of mobile radio equipment characteristics; Sub-part 2: Examples and annexes".
- [10] "The gain resistance product of the half-wave dipole", W. Scott Bennet Proceedings of IEEE vol. 72 No. 2 Dec 1984 pp 1824-1826.
- [11] The new IEEE standard dictionary of electrical and electronic terms. Fifth edition, IEEE Piscataway, NJ USA 1993.
- [12] ETSI TR 100 028 (V1.4.1) (parts 1 and 2): "Electromagnetic compatibility and Radio spectrum Matters (ERM); Uncertainties in the measurement of mobile radio equipment characteristics".
- [13] ETSI TR 100 027: "Methods of measurement for private mobile radio equipment".

3 Definitions, symbols and abbreviations

3.1 Definitions

For the purposes of the present document, the following terms and definitions apply:

accuracy: this term is defined, in relation to the measured value, in clause 4.1.1; it has also been used in the remainder of the document in relation to instruments

Audio Frequency (AF) load: normally a resistor of sufficient power rating to accept the maximum audio output power from the EUT. The value of the resistor is normally that stated by the manufacturer and is normally the impedance of the audio transducer at 1 000 Hz

NOTE: In some cases it may be necessary to place an isolating transformer between the output terminals of the receiver under test and the load.

AF termination: any connection other than the audio frequency load which may be required for the purpose of testing the receiver (i.e. in a case where it is required that the bit stream be measured, the connection may be made, via a suitable interface, to the discriminator of the receiver under test)

NOTE: The termination device is normally agreed between the manufacturer and the testing authority and details included in the test report. If special equipment is required then it is normally provided by the manufacturer.

A-M1: test modulation consisting of a 1 000 Hz tone at a level which produces a deviation of 12 % of the channel separation

A-M2: test modulation consisting of a 1 250 Hz tone at a level which produces a deviation of 12 % of the channel separation

A-M3: test modulation consisting of a 400 Hz tone at a level which produces a deviation of 12 % of the channel separation. This signal is used as an unwanted signal for analogue and digital measurements

antenna: that part of a transmitting or receiving system that is designed to radiate or to receive electromagnetic waves

antenna factor: quantity relating the strength of the field in which the antenna is immersed to the output voltage across the load connected to the antenna. When properly applied to the meter reading of the measuring instrument, yields the electric field strength in V/m or the magnetic field strength in A/m

antenna gain: ratio of the maximum radiation intensity from an (assumed lossless) antenna to the radiation intensity that would be obtained if the same power were radiated isotropically by a similarly lossless antenna

bit error ratio: ratio of the number of bits in error to the total number of bits

combining network: network allowing the addition of two or more test signals produced by different sources (e.g. for connection to a receiver input)

NOTE: Sources of test signals are normally connected in such a way that the impedance presented to the receiver is 50 Ω . Combining networks are designed so that effects of any intermodulation products and noise produced in the signal generators are negligible.

correction factor: numerical factor by which the uncorrected result of a measurement is multiplied to compensate for an assumed systematic error

confidence level: probability of the accumulated error of a measurement being within the stated range of uncertainty of measurement

directivity: ratio of the maximum radiation intensity in a given direction from the antenna to the radiation intensity averaged over all directions (i.e. directivity = antenna gain + losses)

DM-0: test modulation consisting of a signal representing an infinite series of "0" bits

DM-1: test modulation consisting of a signal representing an infinite series of "1" bits

DM-2: test modulation consisting of a signal representing a pseudorandom bit sequence of at least 511 bits in accordance with ITU-T Recommendation O.153

D-M3: test signal agreed between the testing authority and the manufacturer in the cases where it is not possible to measure a bit stream or if selective messages are used and are generated or decoded within an equipment

NOTE: The agreed test signal may be formatted and may contain error detection and correction. Details of the test signal are to be supplied in the test report.

duplex filter: device fitted internally or externally to a transmitter/receiver combination to allow simultaneous transmission and reception with a single antenna connection

error of measurement (absolute): result of a measurement minus the true value of the measurand

error (relative): ratio of an error to the true value

estimated standard deviation: from a sample of n results of a measurement the estimated standard deviation is given by the formula:

$$\sigma = \sqrt{\frac{\sum_{i=1}^n (x_i - \bar{x})^2}{n-1}}$$

x_i being the i^{th} result of measurement ($i = 1, 2, 3, \dots, n$) and \bar{x} the arithmetic mean of the n results considered.

A practical form of this formula is:

$$\sigma = \sqrt{\frac{Y - \frac{X^2}{n}}{n-1}}$$

where X is the sum of the measured values and Y is the sum of the squares of the measured values.

The term **standard deviation** has also been used in the present document to characterize a particular probability density. Under such conditions, the term **standard deviation** may relate to situations where there is only one result for a measurement.

expansion factor: multiplicative factor used to change the confidence level associated with a particular value of a measurement uncertainty

The mathematical definition of the expansion factor can be found in clause D.5.6.2.2 of TR 100 028-2 [12].

extreme test conditions: conditions defined in terms of temperature and supply voltage. Tests are normally made with the extremes of temperature and voltage applied simultaneously. The upper and lower temperature limits are specified in the relevant testing standard. The test report states the actual temperatures measured

error (of a measuring instrument): indication of a measuring instrument minus the (conventional) true value

free field: field (wave or potential) which has a constant ratio between the electric and magnetic field intensities

free space: region free of obstructions and characterized by the constitutive parameters of a vacuum

impedance: measure of the complex resistive and reactive attributes of a component in an alternating current circuit

impedance (wave): complex factor relating the transverse component of the electric field to the transverse component of the magnetic field at every point in any specified plane, for a given mode

influence quantity: quantity which is not the subject of the measurement but which influences the value of the quantity to be measured or the indications of the measuring instrument

intermittent operation: operation where the manufacturer states the maximum time that the equipment is intended to transmit and the necessary standby period before repeating a transmit period

isotropic radiator: hypothetical, lossless antenna having equal radiation intensity in all directions

limited frequency range: a specified smaller frequency range within the full frequency range over which the measurement is made

NOTE: The details of the calculation of the limited frequency range are normally given in the relevant testing standard.

maximum permissible frequency deviation: maximum value of frequency deviation stated for the relevant channel separation in the relevant testing standard

measuring system: complete set of measuring instruments and other equipment assembled to carry out a specified measurement task

measurement repeatability: closeness of the agreement between the results of successive measurements of the same measurand carried out subject to all the following conditions:

- the same method of measurement;
- the same observer;
- the same measuring instrument;
- the same location;
- the same conditions of use;
- repetition over a short period of time.

measurement reproducibility: closeness of agreement between the results of measurements of the same measurand, where the individual measurements are carried out changing conditions such as:

- method of measurement;
- observer;
- measuring instrument;
- location;
- conditions of use;
- time.

measurand: quantity subjected to measurement

noise gradient of EUT: function characterizing the relationship between the RF input signal level and the performance of the EUT, e.g. the SINAD of the AF output signal

nominal frequency: one of the channel frequencies on which the equipment is designed to operate

nominal mains voltage: declared voltage or any of the declared voltages for which the equipment was designed

normal test conditions: conditions defined in terms of temperature, humidity and supply voltage stated in the relevant testing standard

normal deviation: frequency deviation for analogue signals which is equal to 12 % of the channel separation

psophometric weighting network: as described in ITU-T Recommendation O.41

polarization: for an electromagnetic wave, the figure traced as a function of time by the extremity of the electric vector at a fixed point in space

quantity (measurable): an attribute of a phenomenon or a body which may be distinguished qualitatively and determined quantitatively.

rated audio output power: maximum audio output power under normal test conditions, and at standard test modulations, as declared by the manufacturer

rated radio frequency output power: maximum carrier power under normal test conditions, as declared by the manufacturer

shielded enclosure: structure that protects its interior from the effects of an exterior electric or magnetic field, or conversely, protects the surrounding environment from the effect of an interior electric or magnetic field

SINAD sensitivity: minimum standard modulated carrier-signal input required to produce a specified SINAD ratio at the receiver output

stochastic (random) variable: variable whose value is not exactly known, but is characterized by a distribution or probability function, or a mean value and a standard deviation (e.g. a measurand and the related measurement uncertainty)

test load: a 50 Ω substantially non-reactive, non-radiating power attenuator which is capable of safely dissipating the power from the transmitter.

test modulation (test modulating signal): a baseband signal which modulates a carrier and is dependent upon the type of EUT and also the measurement to be performed

trigger device: circuit or mechanism to trigger the oscilloscope timebase at the required instant. It may control the transmit function or inversely receive an appropriate command from the transmitter

uncertainty (random): component of the uncertainty of measurement which, in the course of a number of measurements of the same measurand, varies in an unpredictable way (to be considered as a component for the calculation of the combined uncertainty when the effects it corresponds to have not been taken into consideration otherwise)

uncertainty (systematic): component of the uncertainty of measurement which, in the course of a number of measurements of the same measurand remains constant or varies in a predictable way

uncertainty (limits of uncertainty of a measuring instrument): extreme values of uncertainty permitted by specifications, regulations etc. for a given measuring instrument

NOTE: This term is also known as "tolerance".

uncertainty (standard): expression characterizing, for each individual uncertainty component, the uncertainty for that component

It is the standard deviation of the corresponding distribution.

uncertainty (combined standard): combined standard uncertainty is calculated by combining appropriately the standard uncertainties for each of the individual contributions identified in the measurement considered or in the part of it, which has been considered

NOTE: In the case of additive components (linearly combined components where all the corresponding coefficients **are equal to one**) and when all these contributions are independent of each other (stochastic), this combination is calculated by using the Root of the Sum of the Squares (the RSS method). A more complete methodology for the calculation of the combined standard uncertainty is given in annex D, see in particular clause D.3.12, of TR 100 028-2 [12].

uncertainty (expanded): expanded uncertainty is the uncertainty value corresponding to a specific confidence level different from that inherent to the calculations made in order to find the combined standard uncertainty.

The combined standard uncertainty is multiplied by a constant to obtain the expanded uncertainty limits (see clause 5.3 TR 100 028-1 [12], and also clause D.5 (and more specifically clause D.5.6.2) of TR 100 028-2 [12]).

upper specified AF limit: maximum audio frequency of the audio pass-band. It is dependent on the channel separation

wanted signal level: for conducted measurements a level of +6 dB μ V emf referred to the receiver input under normal test conditions. Under *extreme test conditions* the value is +12 dB μ V emf

NOTE: For analogue measurements the wanted signal level has been chosen to be equal to the limit value of the measured usable sensitivity. For bit stream and message measurements the wanted signal has been chosen to be +3 dB above the limit value of measured usable sensitivity.

3.2 Symbols

For the purposes of the present document, the following symbols apply:

β	$2\pi/\lambda$ (radians/m)
γ	incidence angle with ground plane ($^{\circ}$)
λ	wavelength (m)
ϕ_H	phase angle of reflection coefficient ($^{\circ}$)
η	120π Ohms - the intrinsic impedance of free space (Ω)
μ	permeability (H/m)
AF_R	antenna factor of the receive antenna (dB/m)
AF_T	antenna factor of the transmit antenna (dB/m)
AF_{TOT}	mutual coupling correction factor (dB)
c	calculated on the basis of given and measured data
C_{cross}	cross correlation coefficient
d	derived from a measuring equipment specification
$D(\theta, \phi)$	directivity of the source
d	distance between dipoles (m)
δ	skin depth (m)
d_1	an antenna or EUT aperture size (m)
d_2	an antenna or EUT aperture size (m)
d_{dir}	path length of the direct signal (m)
d_{refl}	path length of the reflected signal (m)
E	electric field intensity (V/m)
E_{DH}^{max}	calculated maximum electric field strength in the receiving antenna height scan from a half wavelength dipole with 1 pW of radiated power (for horizontal polarization) ($\mu\text{V/m}$)
E_{DV}^{max}	calculated maximum electric field strength in the receiving antenna height scan from a half wavelength dipole with 1 pW of radiated power (for vertical polarization) ($\mu\text{V/m}$)
e_{ff}	antenna efficiency factor
ϕ	angle ($^{\circ}$)
Δf	bandwidth (Hz)
f	frequency (Hz)
$G(\theta, \phi)$	gain of the source (which is the source directivity multiplied by the antenna efficiency factor)
H	magnetic field intensity (A/m)
I_0	the (assumed constant) current (A)
I_m	the maximum current amplitude
k	$2\pi/\lambda$
k	a factor from Student's t distribution
k	Boltzmann's constant ($1,38 \times 10^{-23}$ Joules/Kelvin)
K	relative dielectric constant
l	the length of the infinitesimal dipole (m)
L	the overall length of the dipole (m)
l	the point on the dipole being considered (m)
m	measured
p	power
$Pe_{(n)}$	probability of error n
$Pp_{(n)}$	probability of position n
P_r	antenna noise power (W)
P_{rec}	power received (W)
P_t	power transmitted (W)
θ	angle ($^{\circ}$)
ρ	reflection coefficient
r	rectangular distribution
r	the distance to the field point (m)
ρ_g	reflection coefficient of the generator part of a connection

ρ_l	reflection coefficient of the load part of the connection
R_s	equivalent surface resistance (Ω)
σ	conductivity (S/m)
σ	standard deviation
SNR_{b^*}	Signal to noise ratio at a specific BER
SNR_b	Signal to noise ratio per bit
T_A	antenna temperature (Kelvin)
u	U-distribution
U	the expanded uncertainty corresponding to a confidence level of x %: $U = k \times u_c$
u_c	the combined standard uncertainty
u_i	general type A standard uncertainty
u_{i01}	random uncertainty
u_j	general type B uncertainty
u_{j01}	reflectivity of absorbing material: EUT to the test antenna
u_{j02}	reflectivity of absorbing material: substitution or measuring antenna to the test antenna
u_{j03}	reflectivity of absorbing material: transmitting antenna to the receiving antenna
u_{j04}	mutual coupling: EUT to its images in the absorbing material
u_{j05}	mutual coupling: de-tuning effect of the absorbing material on the EUT
u_{j06}	mutual coupling: substitution, measuring or test antenna to its image in the absorbing material
u_{j07}	mutual coupling: transmitting or receiving antenna to its image in the absorbing material
u_{j08}	mutual coupling: amplitude effect of the test antenna on the EUT
u_{j09}	mutual coupling: de-tuning effect of the test antenna on the EUT
u_{j10}	mutual coupling: transmitting antenna to the receiving antenna
u_{j11}	mutual coupling: substitution or measuring antenna to the test antenna
u_{j12}	mutual coupling: interpolation of mutual coupling and mismatch loss correction factors
u_{j13}	mutual coupling: EUT to its image in the ground plane
u_{j14}	mutual coupling: substitution, measuring or test antenna to its image in the ground plane
u_{j15}	mutual coupling: transmitting or receiving antenna to its image in the ground plane
u_{j16}	range length
u_{j17}	correction: off boresight angle in the elevation plane
u_{j18}	correction: measurement distance
u_{j19}	cable factor
u_{j20}	position of the phase centre: within the EUT volume
u_{j21}	positioning of the phase centre: within the EUT over the axis of rotation of the turntable
u_{j22}	position of the phase centre: measuring, substitution, receiving, transmitting or test antenna
u_{j23}	position of the phase centre: LPDA
u_{j24}	stripline: mutual coupling of the EUT to its images in the plates
u_{j25}	stripline: mutual coupling of the three-axis probe to its image in the plates
u_{j26}	stripline: characteristic impedance
u_{j27}	stripline: non-planar nature of the field distribution
u_{j28}	stripline: field strength measurement as determined by the three-axis probe
u_{j29}	stripline: transform Factor
u_{j30}	stripline: interpolation of values for the transform factor
u_{j31}	stripline: antenna factor of the monopole
u_{j32}	stripline: correction factor for the size of the EUT
u_{j33}	stripline: influence of site effects
u_{j34}	ambient effect
u_{j35}	mismatch: direct attenuation measurement
u_{j36}	mismatch: transmitting part
u_{j37}	mismatch: receiving part
u_{j38}	signal generator: absolute output level

u_{j39}	signal generator: output level stability
u_{j40}	insertion loss: attenuator
u_{j41}	insertion loss: cable
u_{j42}	insertion loss: adapter
u_{j43}	insertion loss: antenna balun
u_{j44}	antenna: antenna factor of the transmitting, receiving or measuring antenna
u_{j45}	antenna: gain of the test or substitution antenna
u_{j46}	antenna: tuning
u_{j47}	receiving device: absolute level
u_{j48}	receiving device: linearity
u_{j49}	receiving device: power measuring receiver
u_{j50}	EUT: influence of the ambient temperature on the ERP of the carrier
u_{j51}	EUT: influence of the ambient temperature on the spurious emission level
u_{j52}	EUT: degradation measurement
u_{j53}	EUT: influence of setting the power supply on the ERP of the carrier
u_{j54}	EUT: influence of setting the power supply on the spurious emission level
u_{j55}	EUT: mutual coupling to the power leads
u_{j56}	frequency counter: absolute reading
u_{j57}	frequency counter: estimating the average reading
u_{j58}	Salty man/Salty-lite: human simulation
u_{j59}	Salty man/Salty-lite: field enhancement and de-tuning of the EUT
u_{j60}	Test Fixture: effect on the EUT
u_{j61}	Test Fixture: climatic facility effect on the EUT
V_{direct}	received voltage for cables connected via an adapter (dB μ V/m)
V_{site}	received voltage for cables connected to the antennas (dB μ V/m)
W_0	radiated power density (W/m ²)

3.3 Abbreviations

For the purposes of the present document, the following abbreviations apply:

AF	Audio Frequency
BER	Bit Error Ratio
dB	decibel
emf	electromotive force
ERP	Effective Radiated Power
EUT	Equipment Under Test
FSK	Frequency Shift Keying
GMSK	Gaussian Minimum Shift Keying
GSM	Global System for Mobile telecommunication (Pan European digital telecommunication system)
IF	Intermediate Frequency
LPDA	Log Periodic Dipole Antenna
NaCl	Sodium chloride
NSA	Normalized Site Attenuation
RF	Radio Frequency
RMS	Root Mean Square
RSS	Root-Sum-of Squares
SINAD	SIGNAL Noise And Distortion
TEM	Transverse ElectroMagnetic
VSWR	Voltage Standing Wave Ratio

4 Introduction

An Anechoic Chamber with a Ground Plane is an enclosure, usually shielded, whose internal walls and ceiling are covered with radio absorbing material, normally of the pyramidal urethane foam type. The floor, which is metallic, is not covered and forms the ground plane. The chamber usually contains an antenna mast at one end and a turntable at the other. A typical Anechoic Chamber with a Ground Plane is shown in figure 1.

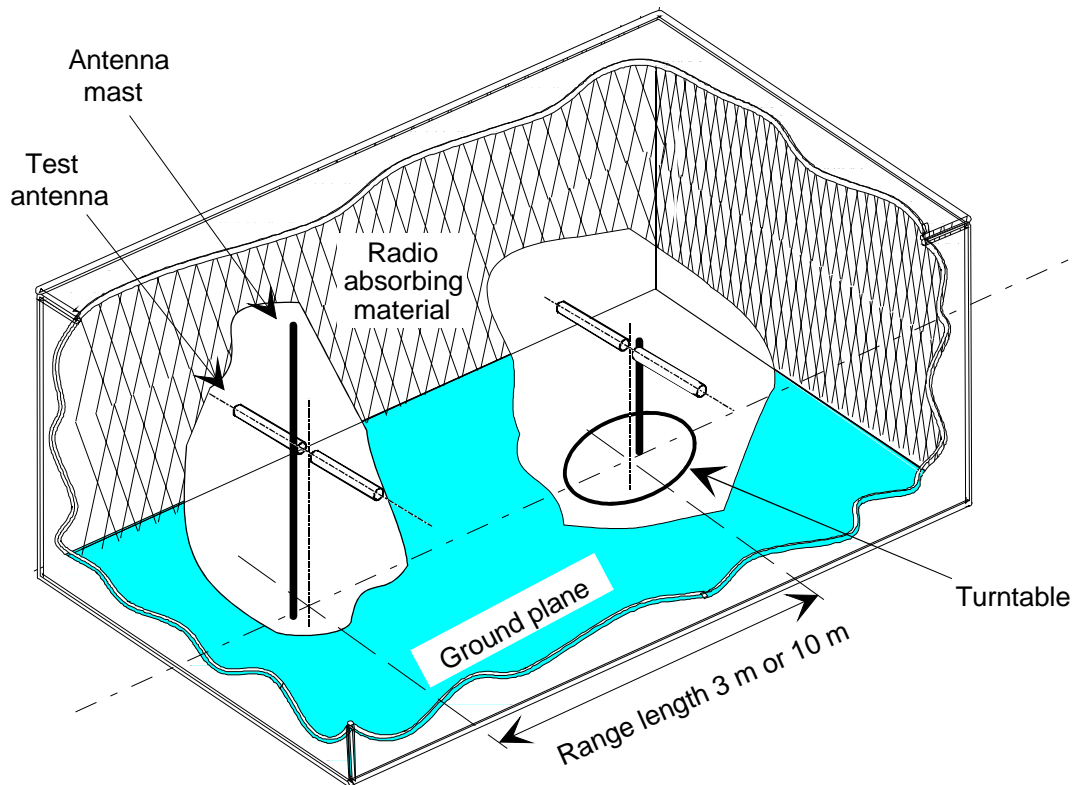

Figure 1: A typical Anechoic Chamber with a Ground Plane

This type of test chamber attempts to simulate an ideal Open Area Test Site (historically, the reference site upon which the majority, if not all, of the specification limits have been set) whose primary characteristic is a perfectly conducting ground plane of infinite extent.

The chamber shielding and radio absorbing material work together to provide a controlled environment for testing purposes. The shielding provides a test space with reduced levels of interference from ambient signals and other outside effects, whilst the radio absorbing material minimizes unwanted reflections from the walls and ceiling which can influence the measurements.

In practice whilst it is relatively easy for shielding to provide high levels (80 dB to 140 dB) of ambient interference rejection (normally making ambient interference negligible), no design of radio absorbing material satisfies the requirement of complete absorption of all the incident power. For example it cannot be perfectly manufactured and installed and its return loss (a measure of its efficiency) varies with frequency, angle of incidence and in some cases, is influenced by high power levels of incident radio energy. To improve the return loss over a broader frequency range, ferrite tiles, ferrite grids and hybrids of urethane foam and ferrite tiles are used with varying degrees of success.

The ground plane creates the wanted reflection path, such that the signal received by the receiving antenna is the sum of the signals received from the direct and reflected transmission paths. The phasing of these two signals creates a unique received signal level for each height of the transmitting antenna (or EUT) and the receiving antenna above the ground plane.

In practice, the antenna mast provides a variable height facility so that the elevation of the test antenna can be optimized for maximum coupled signal in conjunction with the turntable for azimuth angle, between antennas, or, between an EUT and a test antenna.

Both absolute and relative measurements can be performed in an Anechoic Chamber with a Ground Plane. Where absolute measurements are to be carried out, or where the test facility is to be used for accredited measurements, the chamber should be verified. Verification involves comparison of the measured performance to that of an ideal theoretical chamber, with acceptability being decided on the basis of the differences not exceeding some pre-determined limits.

5 Uncertainty contributions specific to an Anechoic Chamber with a Ground Plane

A typical Anechoic Chamber with a Ground Plane comprises three main components:

- a metallic shield;
- radio absorbing material;
- a highly reflective ground plane.

Whilst each of these components is included to improve the quality of the testing environment within the chamber, each has negative effects as well. Below, some positive effects are mentioned as a brief introduction to a discussion of the negative effects and their impact on measurement uncertainty.

5.1 Effects of the metal shielding

The benefits of shielding a testing area can be seen by considering the situation on a typical Open Area Test Site where ambient RF interference can add considerable uncertainty to measurements. Such RF ambient signals can be continuous sources e.g. commercial radio and television, link services, navigation etc. or intermittent ones e.g. CB, emergency services, DECT, GSM, paging systems, machinery and a variety of others. The interference can be either narrowband or broadband.

The Anechoic Chamber with a Ground Plane overcomes these problems by the provision of a shielded enclosure. A shielded enclosure is defined as any structure that protects its interior from the effects of an exterior electric or magnetic field, or conversely, protects the surrounding environment from the effects of an interior electric or magnetic field. The shielding is normally provided by metal panels with continuous electrical contact between adjoining panels and around any doors.

Further advantages of the shield are protection from the weather and the general degradation effects it can have.

5.1.1 Resonances

Any metal shield will act as a reflecting surface and grouping six of them together to form a metal box makes it possible for the chamber to act like a resonant waveguide cavity, if excited. Whilst these resonance effects tend to be narrowband, their peak magnitudes can be high, resulting in a significant disruption of the desired field distribution.

A resonant waveguide cavity mode can, in theory, be excited at any frequency which satisfies the following formula:

$$f = 150 \sqrt{\left(\frac{x}{l}\right)^2 + \left(\frac{y}{b}\right)^2 + \left(\frac{z}{h}\right)^2} \text{ MHz} \quad (5.1)$$

where l , b and h are respectively the length, breadth and height of the chamber in m and x , y and z are mode numbers of which only one is allowed to be zero at any time. As an example, the lowest frequency at which a resonance could occur in a facility which measures 5 m by 5 m by 7 m long is 36,87 MHz.

Caution should be exercised whenever measurements are attempted close to any frequency predicted by this formula, particularly for the lowest values, for which the absorber might offer only poor performance. To improve confidence in the chamber, these lower calculated frequencies could be included in the verification procedure.

5.1.2 Imaging of antennas (or an EUT)

The shield can have a significant impact on the overall performance of the chamber if the absorbing material has inadequate absorption characteristics.

In the limiting case of 0 dB return loss (i.e. zero absorption/perfect reflection) an antenna or EUT will "see" an image of itself in the end wall close behind, the two side walls, the ceiling and, to a lesser extent, in the far end wall, see figure 2. The image in the ground plane is "wanted" as it is a direct consequence of the presence of the ground plane.

In this multi-image environment, the one driven (real) antenna is, in effect, powering a seven element array (of which it is one), instead of a two element array (itself and its image in the ground plane). Major changes result to all of the antenna's electrical characteristics such as input impedance, gain and radiation pattern.

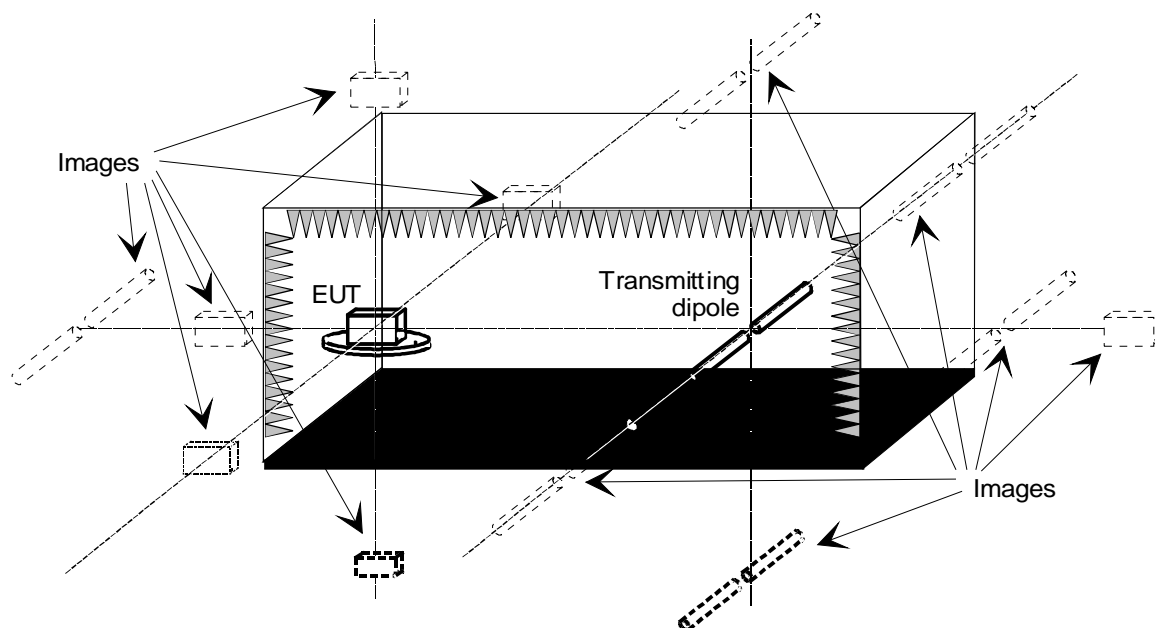

Figure 2: Imaging in the shielded enclosure

No chamber should be used at any frequency for which the absorbing material would perform so poorly as to appear "invisible" as in this example, but any finite value of reflectivity will produce this imaging to an extent.

Good absorption (low reflectivity) will prevent ceiling, side and end wall reflections, whereas poor absorption (high reflectivity) will not only produce imaging of the antennas, or the EUT, in addition to those in the ground plane, but can also contribute numerous high amplitude reflections. Thus the absorbing materials can play a critical role in the chamber's performance.

5.2 Effects of the radio absorbing materials

5.2.1 Introduction

Absorption is the irreversible conversion of the energy of an electromagnetic wave into another form of energy as a result of wave interaction with matter "Fifth edition, IEEE Piscataway" [11] (i.e. it gets hot). The efficiency with which the material absorbs energy is determined by the absorption coefficient. This is defined as the ratio of the energy absorbed by the surface to the energy incident upon it "Fifth edition, IEEE Piscataway" [11]. It is more usual, however, for the reflectivity (i.e. return loss) of an absorbing material to be quoted rather than its absorption, the assumption being that any incident power not reflected is absorbed [11].

Different types of absorbers are available, see figure 3. They all absorb radiated energy to a greater or lesser extent, but possess different mechanical and electrical properties making certain types more suitable for some applications than others.

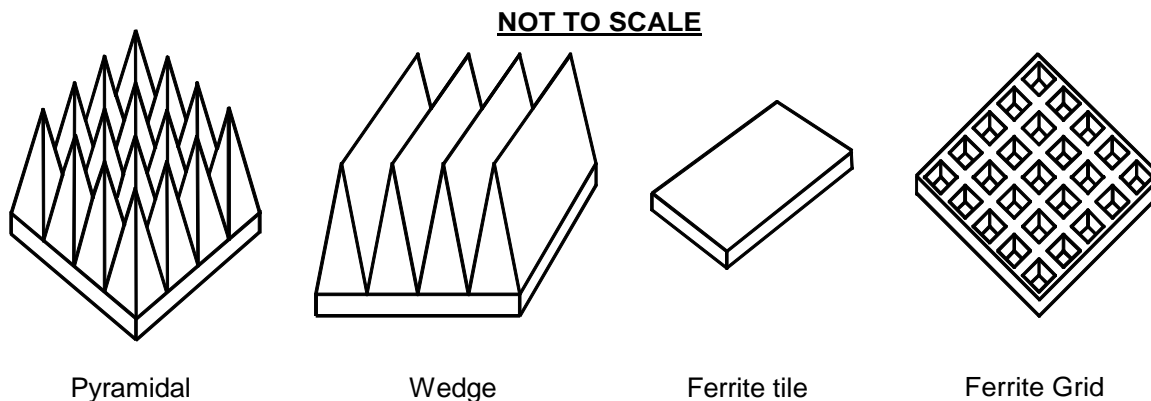

Figure 3: Typical RF absorbers

A review of commonly available types is now given.

5.2.2 Pyramidal absorbers

This type of absorber is manufactured from polyurethane foam impregnated with carbon, and moulded into a pyramidal shape, see figure 3. This shape has inherently wide bandwidth, small polarization dependence and gives reasonably wide angular coverage.

Pyramidal absorbers behave as lossy, tapered transitions, ranging from low impedance at the base to 377Ω at the tip (to match the impedance of free space). They work on the principle that if all of the energy is converted to heat before the base is reached, there is nothing to reflect from the shield.

A line, drawn from the centre of the base through the centre of the tip of the pyramid is termed the normal angle of incidence (0°) and the pyramidal shape maximizes the absorber performance at this angle of incidence. As the angle of incidence increases, however, the return loss degrades, as illustrated in figure 4 for 50° , 60° and 70° angles against absorber thickness.

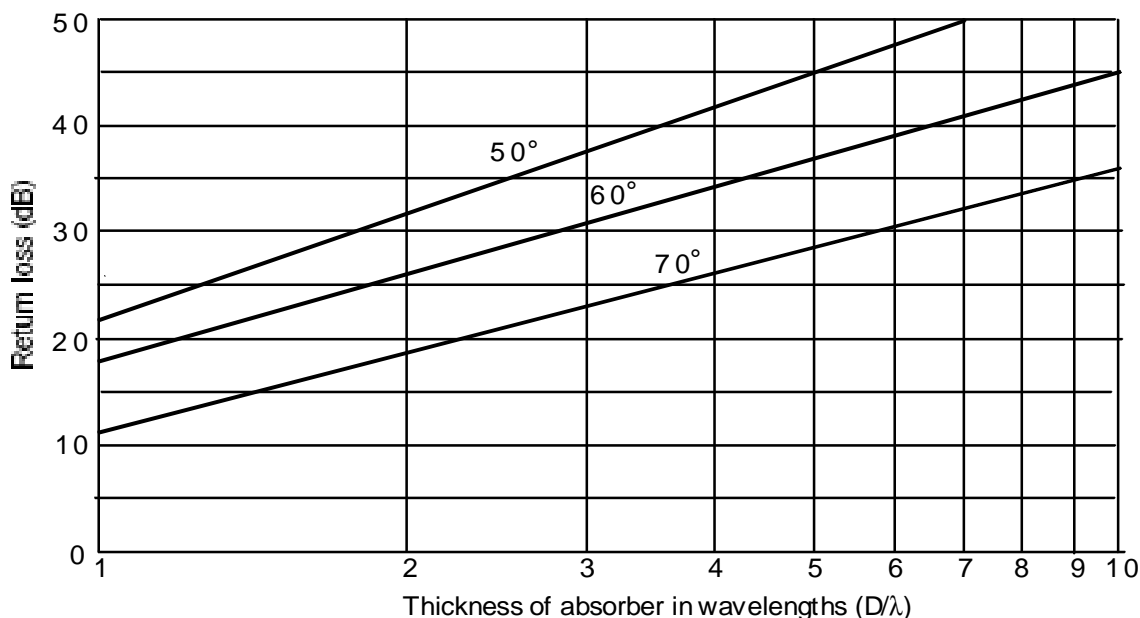

Figure 4: Typical return loss of pyramidal absorber at various incidence angles

This absorption characteristic leads to large reflection coefficients at large angles of incidence where the incident radio energy approaches broadside to the side faces of the pyramids. The reflection is primarily due to impedance mismatch between the incident wave and the absorber impedance taper.

The actual performance varies according to the degree of carbon loading and the shape and size of the cones. At low frequencies its effectiveness in suppressing surface reflections is mainly a function of the cone height to wavelength ratio, the absorption improving as this ratio increases, see figure 5.

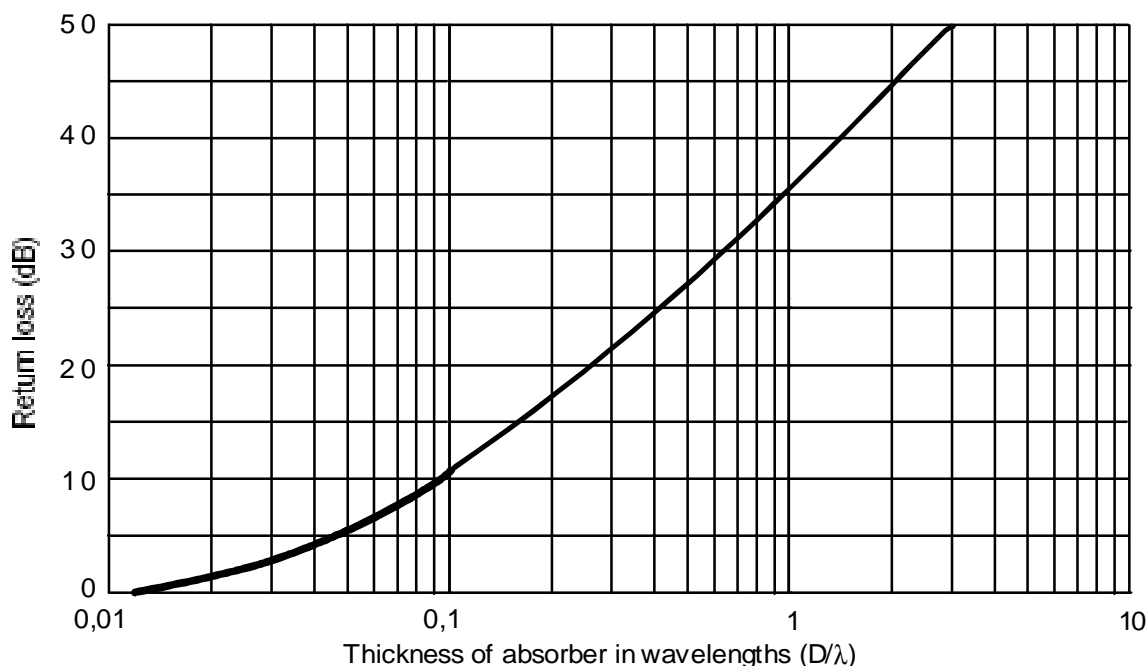

Figure 5: Typical return loss of pyramidal absorber at normal incidence

Longer cones therefore, have better low frequency performance e.g. 0,6 m length cones can only be used effectively down to about 120 MHz, whereas, for comparable performance, 1,778 m cones can be used effectively down to about 40 MHz. This improved performance can, however, only be attained at significantly increased cost and reduction in space efficiency (see table 1).

The high frequency performance of the pyramidal absorbers seems unlimited (see figure 5), but this is not the case. In practice, it is limited by resonant effects of the spacings between the peaks of the pyramids, absorber layout pattern and surface finish of the absorber. In some chambers, mixed size pyramids are used to randomize the absorber pattern to improve its high frequency performance with only minimum degradation at the lower frequencies.

Flammability, space inefficiency and performance degradation over time caused by drooping under their own weight, breaking of the absorber tips and rounding of the valleys are major disadvantages of this type of absorber. However, a hollow cone version is available which reduces the overall weight and improves the mechanical stability. Flame retarding types are also available, but space inefficiency and "fragility" remain major problems with this type of absorber.

5.2.3 Wedge absorbers

Wedge absorbers (see figure 3), are a variation of the polyurethane pyramidal foam type, which tends to overcome the degradation of reflectivity with increasing angle of incidence suffered by pyramidal cones, but at some performance cost.

This improvement is only for cases where the incident wave direction is parallel to the ridge of the wedge as no broadside presents itself at off normal angles as is the case with pyramidal absorbers.

Disadvantages of this type of absorber are degraded performance compared to pyramidal types for both normal angles of incidence and (if used with the ridge perpendicular to the incident wave) when a complete face is broadside to the incident wave.

These effects make wedge absorbers more suitable for use in chambers with range lengths of 10 m or more where they are used to good advantage in the middle sections of the ceilings and side walls.

5.2.4 Ferrite tiles

Ferrite tiles are thin, flat, ceramic blocks typically 15 cm by 8 cm by 1 cm thick (see figure 3). Both thickness and composition of the ferrite material affect their absorption performance. In practice, their layout is also very critical since small air gaps between adjacent tiles can considerably degrade performance at the lowest frequencies (30 MHz to 100 MHz). However, when properly installed this is the frequency range for which they give the most benefit over pyramidal foam absorbers. They are generally manufactured to give about 15 dB to 20 dB return loss at 30 MHz (see figure 6).

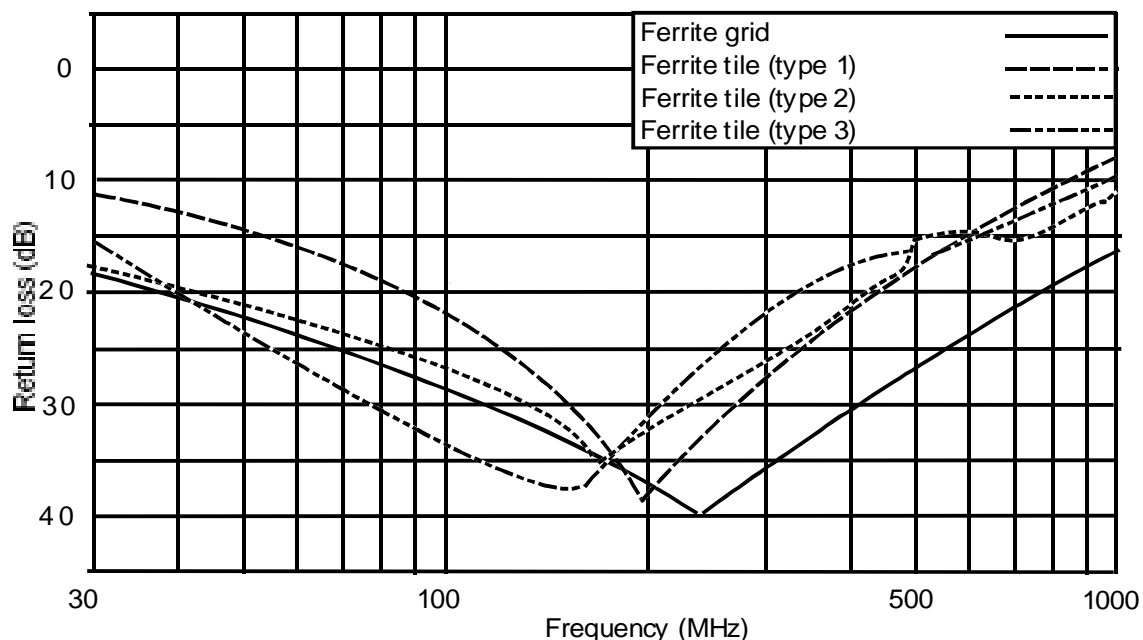

Figure 6: Normal incidence return loss variation of a ferrite grid and three different designs of ferrite tile against frequency

Their main advantages are that they are thin (typically 1 cm) so the shielded enclosure outside dimensions are relatively small compared to pyramidal foam for the same internal volume (see table 1). Ferrite tiles have a durable surface and a stable performance with time.

Disadvantages are cost, the strong dependence of the reflectivity performance on both polarization and angle of incidence and possible non linear performance due to saturation at high field strengths.

Due to their relatively high cost ferrite tiles are mainly built up into 1 m or 2 m square blocks which are placed strategically in the chamber under pyramidal foam absorbers in the middle sections of the side walls and ceiling - the main reflection paths between antennas (or between an antenna and EUT). They are also used on the end walls to improve absorption and to reduce image coupling.

This combination of ferrite tiles and pyramidal foam absorbers is more cost effective in performance terms than a fully ferrited room.

5.2.5 Ferrite grids

Ferrite grids are typically 10 cm by 10 cm by 2,5 cm thick. They provide absorption from 30 MHz to 1 000 MHz. The grid structure provides better power handling characteristics and avoids the installation problems associated with plain tiles. Their absorption characteristics are basically the same as for ferrite tiles (see figure 6).

5.2.6 Urethane/ferrite hybrids

Urethane/ferrite hybrid absorbers (as introduced in clause 5.2.4) consist of pyramidal foam absorber bonded to a ferrite tile backing. They are designed in such a way that the ferrite tiles are active at the low frequencies, where the pyramidal foam absorbers are not very efficient, whilst the pyramidal absorbers take over at higher frequencies.

A disadvantage is the impedance mismatch between the ferrite base and the dielectric pyramids can result in performance degradation in some frequency ranges.

In a similar manner to the ferrite tile, the hybrid absorber is used in the middle sections of the side walls and ceiling - the main reflection paths between antennas (or between an antenna and EUT). They are also used on the end walls to improve absorption and to reduce image coupling.

5.2.7 Performance comparison

Tables 1 and 2 detail numerous relative parameters for the different absorber types discussed above. Table 1 gives the physical parameters relating to an Anechoic Chamber with a Ground Plane of internal testing dimensions of 8 m by 3 m by 5 m high (the minimum height which allows a 1 m to 4 m height scan). Table 2 details the return loss (at 0° angle of incidence) for the various absorber types considered in table 1. The data in table 2 is shown graphically in figure 7.

Table 1: Typical physical parameters of an 8 m by 3 m by 5 m Anechoic Chamber with a Ground Plane for various absorber types

Features	Pyramidal 0,66 m	Pyramidal 1,778 m	Ferrite tiles	Ferrite grid	Hybrid
Inside dimensions	8 m by 3 m by 5 m	8 m by 3 m by 5 m	8 m by 3 m by 5 m	8 m by 3 m by 5 m	8 m by 3 m by 5 m
Outside dimensions (approx.)	9,32 m by 4,32 m by 5,66 m	11,56 m by 6,56 m by 6,78 m	8,02 m by 3,02 m by 5,01 m	8,05 m by 3,05 m by 5,025 m	9,34 m by 4,34 m by 5,67 m
Overall volume	228 m ³	514 m ³	121 m ³	123 m ³	230 m ³
Flammable	yes	yes	no	no	yes
Risk of damage	high	high	low	low	high
Floor absorbers	moveable	fixed	fixed	fixed	fixed
Frequency range (MHz)	80 to > 1 000	30 to > 1 000	30 to > 500	30 to > 1 000	30 to > 1 000

Table 2: Typical return loss at 0° incidence for various absorbers against frequency

Frequency	Pyramidal 0,66 m	Pyramidal 1,778 m	Ferrite tiles	Ferrite grid	Hybrid
30 MHz	7 dB	15 dB	17 dB	17 dB	16 dB
80 MHz	15 dB	25 dB	25 dB	20 dB	18 dB
120 MHz	19 dB	30 dB	26 dB	20 dB	20 dB
200 MHz	25 dB	35 dB	25 dB	37 dB	20 dB
300 MHz	30 dB	40 dB	23 dB	25 dB	20 dB
500 MHz	35 dB	45 dB	18 dB	23 dB	20 dB
800 MHz	40 dB	50 dB	14 dB	18 dB	25 dB
1 GHz	50 dB	50 dB	12 dB	15 dB	25 dB
3 GHz	50 dB	50 dB	6 dB	10 dB	30 dB
10 GHz	50 dB	50 dB	-	-	30 dB
18 GHz	50 dB	50 dB	-	-	35 dB

All of these types of absorber dissipate the energy incident on their surfaces in the form of heat. When in the presence of high value fields, the power absorbed in the foam variety can exceed its ability to dissipate the heat, and the resulting increase in temperature degrades its performance. This is not normally a problem with ferrite types.

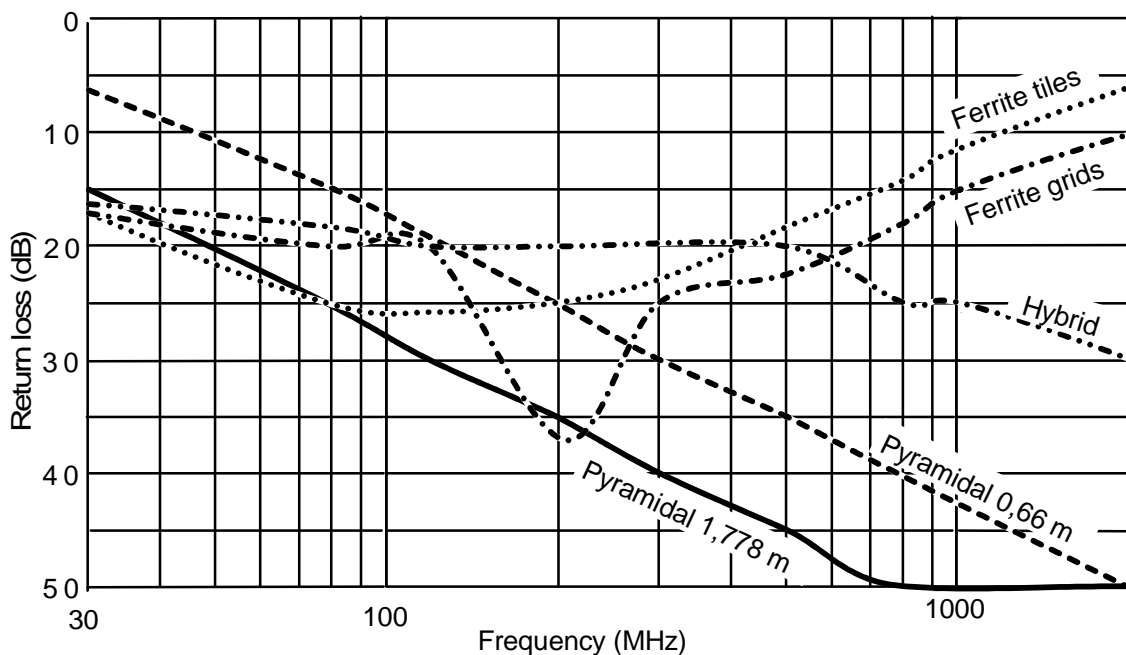

Figure 7: Return loss variation with frequency of the absorber performance given in table 2

5.2.8 Reflection in an Anechoic Chamber with a Ground Plane

As has been stated, the absorbing materials used and their layout play a critical role in the chamber's performance. A plan view of an Anechoic Chamber with a Ground Plane with its end and side walls covered in pyramidal foam absorbers is shown in figure 8. Mounted in the chamber are two dipoles (shown for illustration purposes only, although this is a common arrangement found in test methods and the verification procedure). Various single and double bounce reflection paths are also illustrated.

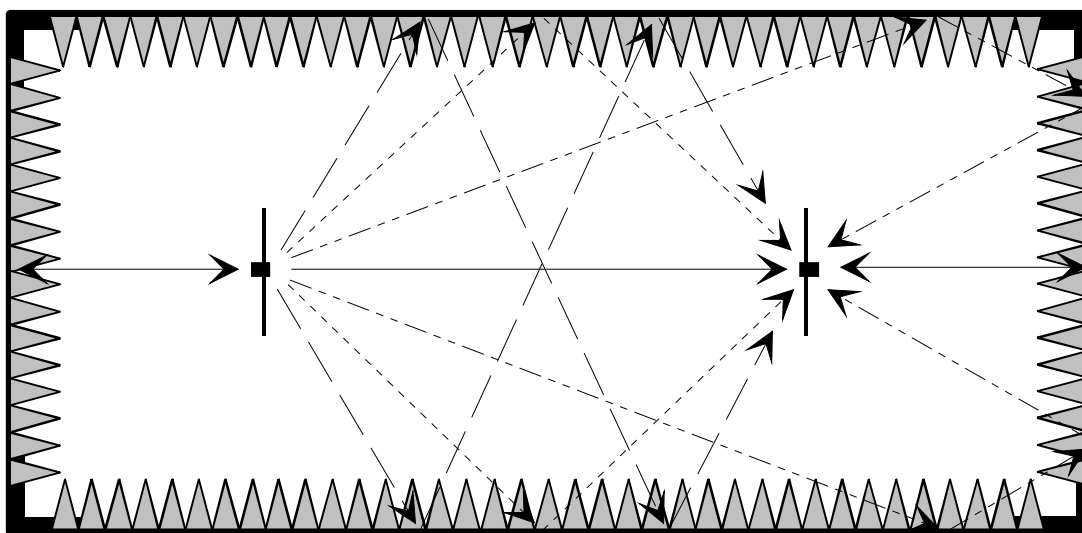

Figure 8: Plan view of an Anechoic Chamber with a Ground Plane which uses pyramidal absorber

The single bounce reflection paths via the end walls are at normal incidence to the absorbers, and since the absorbers are at maximum efficiency at normal incidence the reflections are of a low amplitude. However the amplitude of the worst case reflections, the single bounce paths between the antennas via the side walls, are dependant on the angles of incidence, which themselves are dependant on the geometry (cross section and range length) of the chamber. The ceiling provides another single bounce reflection path.

The main reflection is the reflection from the ground plane, and all other reflections, whether they are from the absorber itself or from extraneous sources (see clause 5.2.10), interfere with the required field and result in measurement uncertainty. The situation is further complicated by the directional nature of the dipoles, reflections in the E-plane of the dipole being reduced in amplitude when compared to the case for the orthogonal polarization, as a result of the dipole's radiation pattern.

As an example of the magnitude of the problem, the following is calculated for illustrative purposes. A typical chamber of 5 m by 5 m by 7 m long, employing 0,66 m pyramidal foam absorbers is used over a 3 m range length. The angles of incidence on the side walls and ceiling of the main single bounce reflection paths are:

$$\tan^{-1}(1,5 / 2,5) = 31,0^{\circ} \quad (5.2)$$

Assuming a frequency of 80 MHz, the reflectivity at this angle of incidence is approximately 15 dB. If the polarization of the transmitting dipole is taken as horizontal, then its directivity in the horizontal plane reduces the magnitude of the side wall reflections by 1,9 dB which, in addition to the extra path length loss (relative to the direct ray) of 5,8 dB, leads to the amplitudes of the three main one-bounce reflections being -22,7 dB, -22,7 dB and -20,8 dB for the two side walls and ceiling respectively (these levels being relative to the amplitude of the direct path).

NOTE: In a chamber of identical cross section but offering a 10 m range length, these three main interfering rays have greater amplitudes of approximately -13,4 dB, -13,4 dB and -12,0 dB as a result of increased reflectivity from the absorbing materials (grazing angle of incidence), less relative path loss (the path lengths are more nearly equal) and less benefit from the directivity of the dipole pattern.

Whilst the addition of these rays is more complex than just a straightforward addition (and for a full analysis one should also include multiple bounce reflections), their amplitudes serve to illustrate the potential problem of signal level uncertainty since, again for illustrative purposes only, a single -20 dB interfering signal can, depending on its phasing, enhance or reduce the received signal level by +0,83 dB or -0,92 dB respectively. Table 3 illustrates the uncertainty caused by a single unwanted interfering signal.

Table 3: Uncertainty in received signal level due to a single unwanted interfering signal

Ratio of unwanted to wanted signal level	Received level uncertainty	Ratio of unwanted to wanted signal level	Received level uncertainty
-30,0 dB	+0,27 dB -0,28 dB	-9,0 dB	+2,64 dB -3,81 dB
-25,0 dB	+0,48 dB -0,50 dB	-8,0 dB	+2,91 dB -4,41 dB
-20,0 dB	+0,83 dB -0,92 dB	-7,0 dB	+3,21 dB -5,14 dB
-17,5 dB	+1,09 dB -1,24 dB	-6,0 dB	+3,53 dB -6,04 dB
-15,0 dB	+1,42 dB -1,70 dB	-5,0 dB	+3,88 dB -7,18 dB
-14,0 dB	+1,58 dB -1,93 dB	-4,0 dB	+4,25 dB -8,66 dB
-13,0 dB	+1,75 dB -2,20 dB	-3,0 dB	+4,65 dB -10,69 dB
-12,0 dB	+1,95 dB -2,51 dB	-2,0 dB	+5,08 dB -13,74 dB
-11,0 dB	+2,16 dB -2,88 dB	-1,0 dB	+5,53 dB -19,27 dB
-10,0 dB	+2,39 dB -3,30 dB	0,0 dB	+6,04 dB -∞ dB

For optimized chamber performance therefore, the middle sections of the ceiling and side walls of Anechoic Chambers with Ground Planes should be carefully constructed to provide the highest values of absorption in the chamber, especially for range lengths greater than 3 m. From a measurement viewpoint, inside the chamber, the amount of reflection from the walls has a direct effect on the "quality" of the measurement.

Experience has shown that in chambers which have 0,66 m pyramidal absorbers the overall performance has three distinct stages:

- below about 150 MHz or so the amplitude of reflections from the walls and ceiling can be observed to degrade the operation of the facility. The shielded enclosure may act as a large cavity resonator, although all possible modes may not be excited as they are also dependant on the configurations of the test equipment and EUT;
- from about 150 MHz up to a few hundred MHz most of the components (e.g. absorber dimensions) return to full specification and the chamber tends to "behave" quite well;
- at very high frequencies, arbitrarily hundreds of MHz to well above 1 000 MHz resonances can be set up by the physical dimensions of the absorber material which can negate the fact that the absorber materials themselves have good performance characteristics at these frequencies.

In the present document, the uncertainty contributions due to reflectivity of the absorbers are estimated in annex A and are given representative symbols as follows:

- u_{j01} is used for the contribution associated with the reflectivity of the absorbing material between the EUT and test antenna in test methods;
- u_{j02} is used for the contribution associated with the reflectivity of the absorbing material between the substitution or measuring antenna and test antenna in test methods;
- u_{j03} is used for the contribution associated with the reflectivity of the absorbing material between transmitting antenna and receiving antenna in verification procedures.

5.2.9 Mutual coupling due to imaging in the absorbing material

Mutual coupling is the mechanism which produces changes in the electrical behaviour of an EUT or antenna when placed close to a conducting surface, another antenna, etc. The changes can include, amongst others, detuning, gain variation and changes to the radiation pattern. Whilst the absorbing materials help to reduce these effects, it does not remove them completely. To avoid the major effects of any such performance changes, it is a stipulation in all tests, that no part of any antenna, or EUT, should at any time, approach to within less than 1 m of the absorbing material. Where this condition cannot be satisfied, testing should not be carried out.

The magnitude of the effects on the electrical characteristics due to the degree of imaging in the absorber/shield of the chamber are estimated in annex A and the uncertainty contributions due to the mutual coupling effects to the absorber materials are given representative symbols as follows:

- u_{j04} is used for the uncertainty contribution associated with the mutual coupling of the EUT to its images in the absorbing material in test methods;
- u_{j05} is used for the uncertainty contribution associated with the de-tuning effect of the absorbing material on the EUT in test methods;
- u_{j06} is used for the uncertainty contribution associated with the substitution, measuring or test antenna and its image in the absorbing material in test methods;
- u_{j07} is used for the uncertainty contribution associated with the mutual coupling between the transmitting or receiving antenna and its image in the absorbing material in verification procedures.

5.2.10 Extraneous reflections

Within the chamber, reflecting objects such as internal lighting, cameras and safety circuits (which are normally used in chambers where high power fields are generated) should be avoided (or their effects minimized) as they will have a direct effect on the quality of the measurement at that site. Similarly, the materials from which the antenna mast and turntable are constructed should be of low relative dielectric constant.

5.3 Effects of the ground plane

5.3.1 Reflections

Far from a perfectly conducting ground plane, at a distance sufficient to make the difference between the direct and reflected path lengths negligible and the direct and reflected waves appear parallel to each other, the amplitude of the reflected wave is equal to the amplitude of the direct wave. When these two waves add "in phase" the electric field strength doubles (6 dB gain) whereas, at another point the two waves are "out of phase" and cancel entirely resulting in no net electric field. Therefore, over a perfectly conducting ground plane at infinite distance it is possible to obtain field strengths varying from +6 dB to -∞ dB on a test site relative to the free space field strength (see figure 9a).

In practice, the distance between the EUT and the test antenna is not infinite, the direct and reflected waves are not parallel and their path lengths can differ substantially. In this condition the field measured by the test antenna can alternate between peaks and nulls many times as the test antenna is raised and lowered through the available height range. The difference in path lengths, along with any directivity of the test antenna in the vertical plane result in the direct and reflected waves not being equal in amplitude. As a result, when they add "in phase" the peak will be less than +6 dB and when they are out of phase their amplitudes do not fully cancel, resulting in an electric field strength greater than $-\infty$ dB (null filling), see figure 9b.

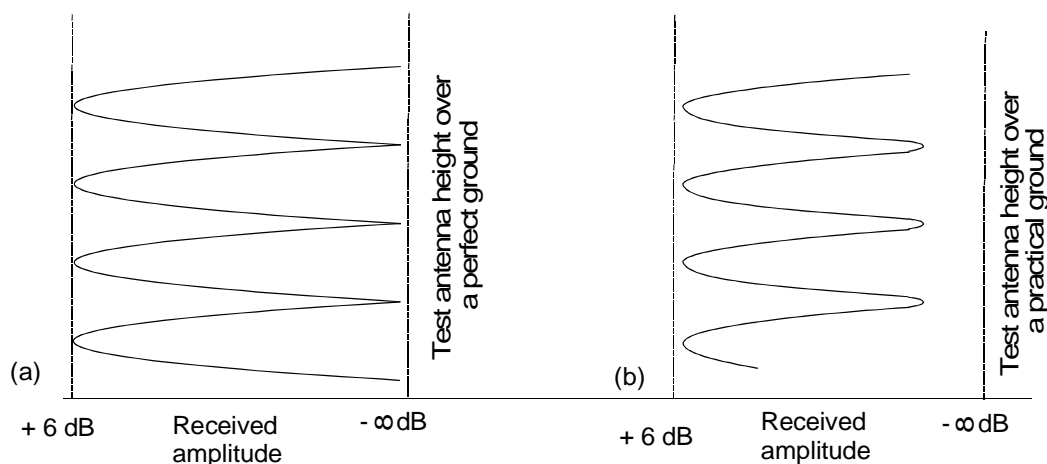

Figure 9: Comparison of the received amplitude for an ideal site against a practical site

For testing purposes, when it is necessary to generate a uniform field in, for example, immunity measurements, the region of interest is either a particular volume or area into which the EUT will be placed. The degree of uniformity of the fields within this volume is affected by many factors, such as the relative positions of the radiating antenna and the EUT, their radiation patterns, the size and construction of the EUT, etc.

The interaction of the direct and ground reflected waves can produce regular sharp amplitude nulls in the volume occupied by the EUT or receiving/measuring antenna (see figure 10).

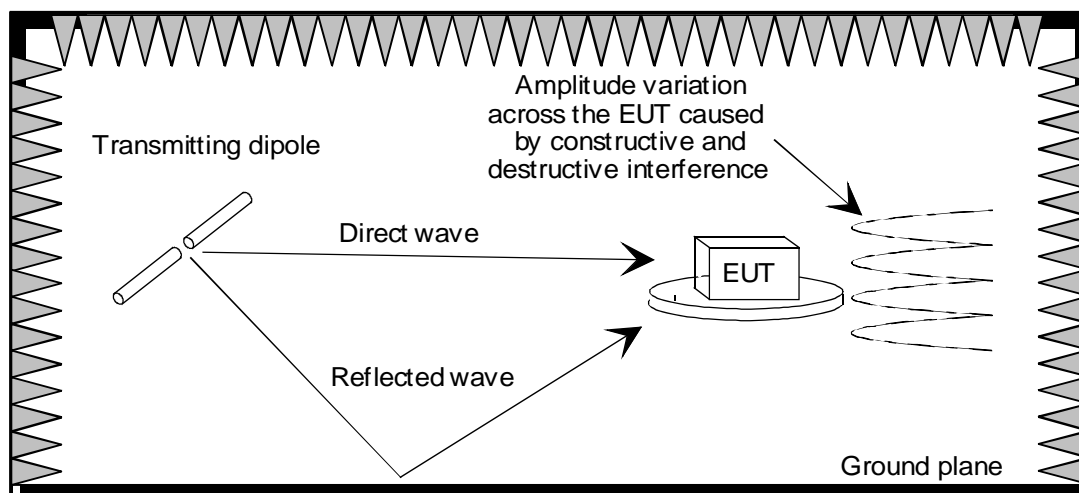

Figure 10: Amplitude variation in the test volume

The smaller the EUT the more uniform the field across it. As a general rule, for minimum measurement uncertainty during tests, its size should be significantly smaller than the distance between the nulls. The nulling effect is more severe in the vertical plane than the horizontal plane of the volume occupied by the EUT, and it is worst when the transmitting antenna is at its maximum height (4 m), and horizontally polarized (since the ground plane is fully illuminated by the omni-directional pattern of the dipole in this polarization). In this worst case, the maximum vertical dimension an EUT or receiving/measuring antenna can have on a 3 m test range is between 0,4 to 0,6 wavelengths (depending on the frequency, height on the mast, mutual coupling effects etc.) for the amplitude of the field across it to vary by no more than -3 dB (relative to its centre) at its edges.

The phase variation is not curved as in the case of a point source in free space, (see TR 102 273-1-1 [8]) but tends to be more linear with a tilt, relative to vertical, which is roughly equivalent to the angle at which a single source, placed midway between the real antenna on the mast and its image, would impinge on the receive aperture. If one were to impose, say, a phase variation across the receive aperture of no greater than 22,5°, the maximum size of an EUT would be much reduced (typically by a factor of at least 2) from the 0,4 to 0,6 wavelengths quoted, to a point where the test site would be virtually unusable at some frequencies.

5.3.2 Mutual coupling between antennas and in the ground plane

Mutual coupling, as stated in clause 5.2.9, is the mechanism which produces changes in the electrical behaviour of an EUT (or antenna) when placed close to a conducting surface, another antenna, etc. The changes can include detuning, gain variation and distortion of the radiation pattern.

To illustrate the effects of mutual coupling to the ground plane it is useful to start by considering the interaction between two closely spaced resonant dipoles in **free space** i.e. without a ground reflection. Some texts "Antenna theory" [2] show that in this condition, noticeable changes to a dipole's input impedance result for dipole to dipole spacings of up to 10 wavelengths (assuming side by side orientation).

In a transmit/receive system between two resonant dipoles the input impedance of the driven dipole (Z_{in1}) can be calculated as a combination of its own self impedance (Z_{11}), the self impedance of the other dipole (Z_{22}) and a contribution from the mutual interaction between them. The mutual interaction comprises both resistive (R_{12}) and reactive (X_{12}) components and the relationship between them can be shown to be:

$$Z_{in1} = Z_{11} - \frac{(R_{12} + jX_{12})^2}{Z_{22}} \quad (5.3)$$

The variations with separation distance of the mutual resistance and reactance for two half wavelength dipoles are shown in figure 11.

EXAMPLE 1: if the range length is 3 m and the frequency is 30 MHz, from figure 11, $R_{12} = 29,11 \Omega$ and $X_{12} = -34,36 \Omega$. As a result, $Z_{in1} = 88,32 + j 60,98 \Omega$ whereas with no coupling it would have been $73 + j 42,5 \Omega$.

EXAMPLE 2: the input impedance of the transmitting antenna for two half wavelength dipoles spaced half a wavelength apart, becomes $70 + j 30,5 \Omega$ as a result of the mutual coupling.

Along with the change in input impedances arising from mutual coupling, there will be a signal strength loss due to the associated mismatch to the line. However, it is not only the dipole impedance that changes as a result of its proximity to another. The radiation pattern and gain (or antenna factor) will also change. Indeed, the gain change has been shown (Proceedings of IEEE vol.72 No.2 [10]) to have an unexpected relationship with the radiation resistance - namely that their product remains constant no matter how much either quantity may vary. Specifically:

$$\text{Gain} = 120 / \text{Resistance} \quad (5.4)$$

As a result, for the first example above (30 MHz dipoles spaced 3 m apart) a gain loss of 0,83 dB occurs whilst for the second example of two dipoles half a wavelength apart an increase of 0,19 dB in the gain results. Simply increasing the range length to minimize mutual coupling, requires a receiver with sufficient sensitivity to cope with the increased path loss.

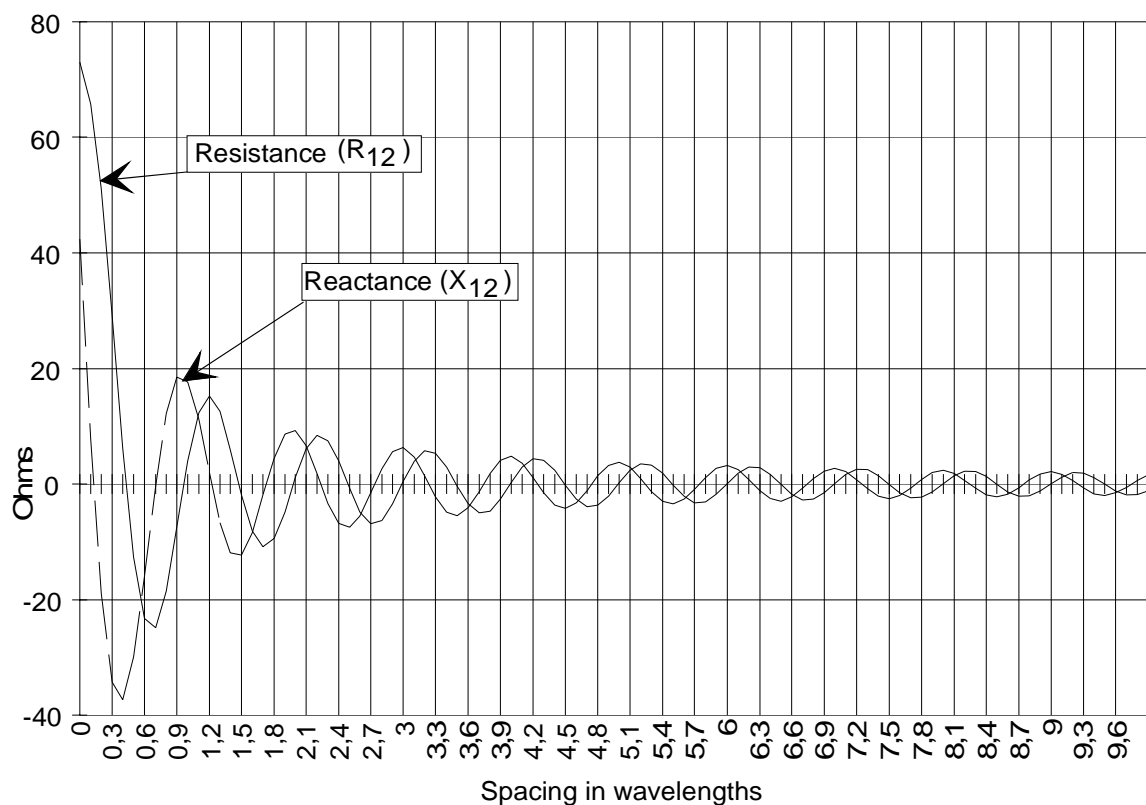

Figure 11: The mutual resistance and reactance of two side-by-side dipoles, each $\lambda/2$

Over a ground plane, this mutual coupling situation becomes further complicated by the creation of images of both antennas. Without giving a full analysis, it is indicative to look at the case of a single dipole and the effect its image (i.e. the presence of the ground plane) has on its performance. For this configuration, the orientation of the dipole is important. For a horizontal dipole, the input impedance can be shown to be:

$$Z_{in} = Z_{11} - Z_{12}$$

whereas for a vertical one,

$$Z_{in} = Z_{11} + Z_{12}$$

where $Z_{12} = R_{12} + jX_{12}$. Again, the gain of the dipole will change in line with its input resistance and for the worst case of a horizontal dipole, the variation in gain against height above the ground plane is given in figure 12. Even for a spacing above the ground plane of more than two wavelengths, the figure shows that the dipole's gain can vary by $\pm 0,5$ dB with the ripple being slow to diminish even at spacings of 5 wavelengths.

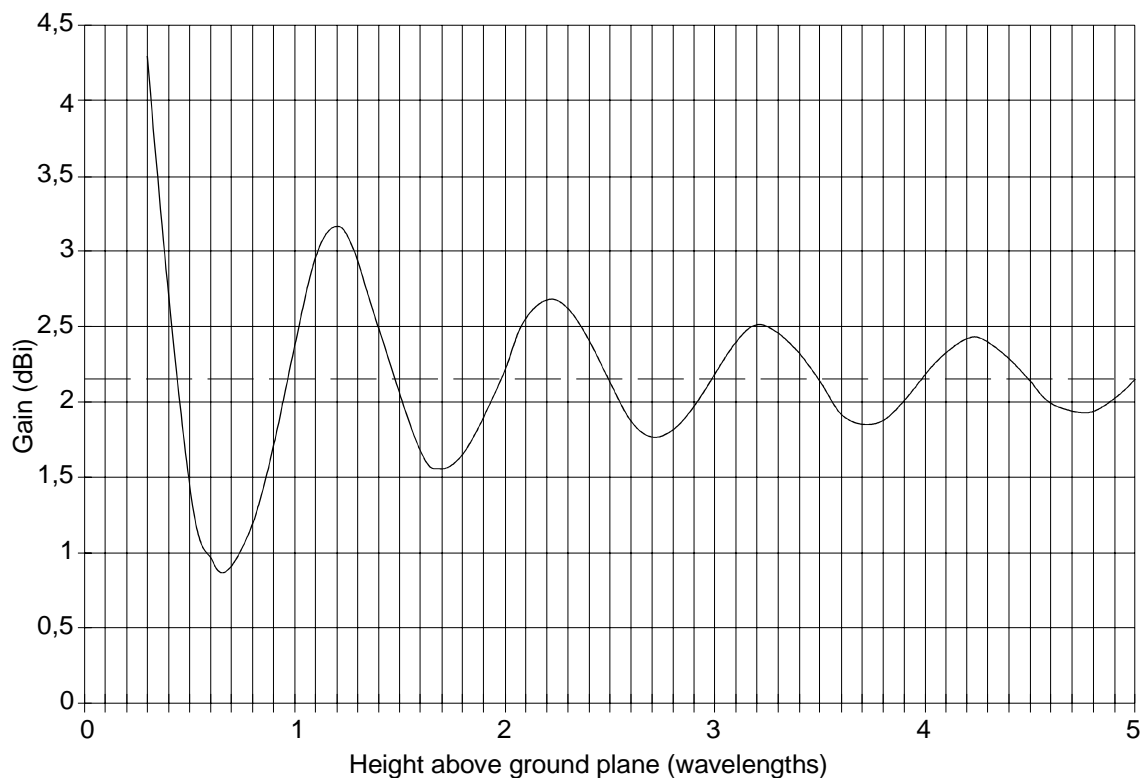

Figure 12: Gain variation of a horizontal half wavelength dipole above a ground plane

The real life testing situation is very much more involved than the theoretical coupled dipole examples given above since there is interaction not only between the transmitting and receiving devices and their own images (whether an EUT and antenna or two antennas) but also between each device and the image of the other and between images.

NOTE: The overall mutual coupling effect between two ANSI dipoles over a ground plane have been modelled and figures are provided as "Mutual coupling and mismatch loss" correction factors in the individual test procedures.

Furthermore, for an EUT, the magnitude of the overall effect will be dependant on its size, polarization, frequency, etc.

Mutual coupling to the ground plane for a typical test in an Anechoic Chamber with a Ground Plane is illustrated in figure 13.

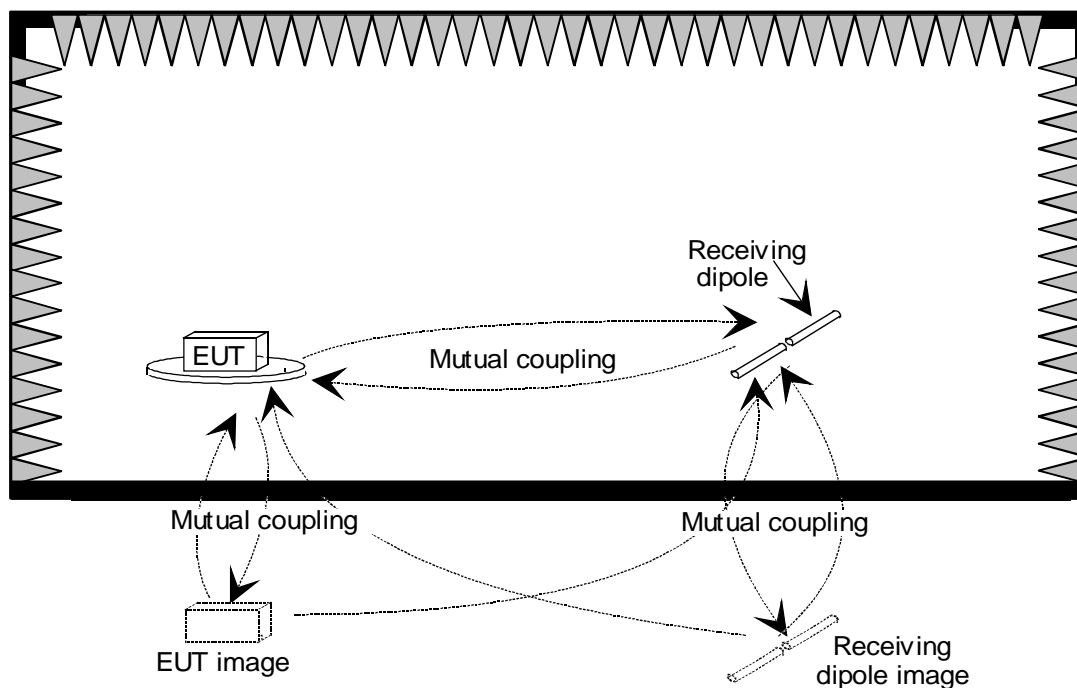

Figure 13: Mutual coupling in the ground plane

The magnitude of the effects on the electrical characteristics of an EUT or antenna due to the mutual coupling between them and/or the ground plane are estimated in annex A and the uncertainty contributions which result are given representative symbols as follows:

- u_{j08} is used for the uncertainty contribution associated with the amplitude effect of the test antenna on the EUT in test methods;
- u_{j09} is used for the uncertainty contribution associated with the de-tuning effect of the test antenna on the EUT in test methods;
- u_{j10} is used for the uncertainty contribution associated with the mutual coupling between transmitting antenna and receiving antenna in verification procedures;
- u_{j11} is used for the uncertainty contribution associated with the mutual coupling between substitution or measuring antenna and test antenna in test methods;
- u_{j12} is used for the uncertainty contribution associated with the interpolation of mutual coupling and mismatch loss correction factors (factors to allow for coupling between ANSI dipoles only);
- u_{j13} is used for the uncertainty contribution associated with the change in gain/sensitivity of an EUT due to mutual coupling to its image in the ground plane in test methods;
- u_{j14} is used for the uncertainty contribution associated with the change in gain of the substitution/measuring or test antenna to its image in the ground plane in test methods;
- u_{j15} is used for the uncertainty contribution associated with the change in gain of the transmitting or receiving antenna to its image in the ground plane in verification procedures.

5.4 Other effects

5.4.1 Range length and measurement distance

Range length is defined as the horizontal distance between the phase centres (or volume centres) of the EUT and test antenna or between antennas. Measurement distance, on the other hand, is defined as the actual distance between the phase centres (or volume centres) of the EUT and test antenna. The distinction between the two parameters is illustrated in figure 14 where the test antenna is at 4 m.

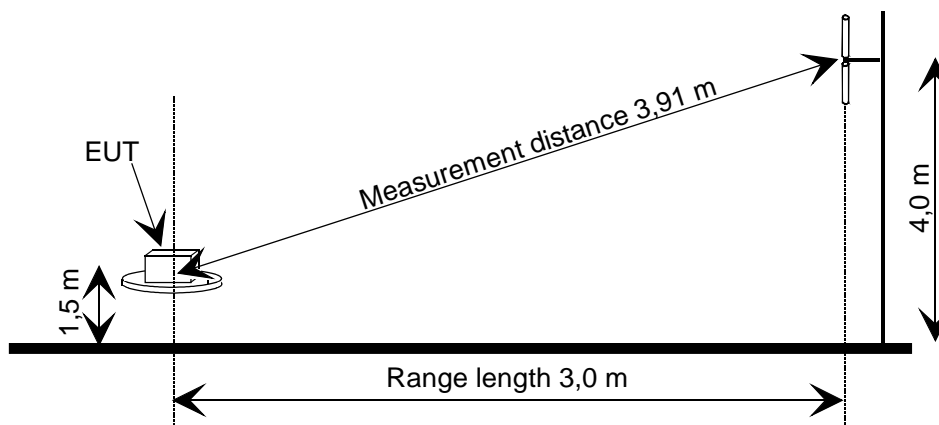

Figure 14: Range length and measurement distance

The range length over which any radiated test is carried out should always be adequate to enable far-field testing of the EUT i.e. range length should always be greater than or equal to:

$$\frac{2(d_1 + d_2)^2}{\lambda} \quad (5.5)$$

where:

d_1 is the largest dimension of the EUT/dipole after substitution (m);

d_2 is the largest dimension of the test antenna (m);

λ is the test frequency wavelength (m).

Measurement uncertainty arises when the range length does not satisfy the above far-field requirement. The magnitude of its effect is estimated in annex A and:

u_{j16} is used for the uncertainty contribution associated with the range length (when it does not meet the far-field requirement).

For distances equal to or less than $(d_1 + d_2)^2 / 4\lambda$ the magnitude of the contribution is unspecified, since measurements should not be carried out at these separations (the uncertainty is too large).

The radiated test methods in the present document all involve a substitution measurement. A substitution measurement always involves two stages. One stage is the measurement on the EUT, the other stage involves a similar measurement using a reference (normally a dipole) against which the first result can be compared and evaluated.

Complications arise when the radiated test is carried out over a reflective ground plane, since this requires the raising and lowering of the test antenna to maximize the received signal. Two uncertainties are introduced by this action.

The first uncertainty concerns the radiation pattern of the test antenna in the vertical plane. For a vertically polarized dipole, the directivity in the vertical plane means that the higher on the mast that the test antenna peaks, the larger the angle subtended to the device at the other end and hence the further down the side of the beam the illumination falls.

EXAMPLE: For a peak height of 1,5 m, the direct signal to the test device comes from the boresight of the beam, whereas for a peak height of 4 m, an angle of $39,8^\circ$ is subtended over a 3 m range length. This corresponds to a fall off of 3,1 dB for a half wavelength dipole (see figure 15).

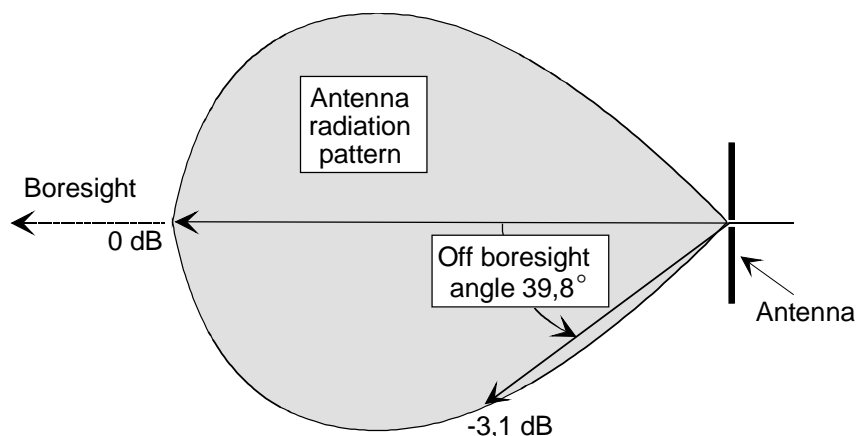

Figure 15: Signal loss due to off boresight angle

Whilst this is an over simplification of the case (no account has been paid to the reflected signal) nonetheless it illustrates the potential magnitude of the effect. It should be noted that this effect does not occur when dipoles or bicones are used in horizontal polarization. Corrections can be obtained for signal loss due to off boresight angles in the elevation plane (see figure A.8 of TR 102 273-1-2 [9]). There is, however, an uncertainty associated with this correction factor:

u_{j17} is used for the uncertainty of the correction factor for off boresight angle in the elevation plane due to the signal attenuation with increasing elevation offset angle.

The second is that a measurement distance error occurs when the peak position found on the mast during the substitution is at a different height to that for the measurement on the EUT.

EXAMPLE: Suppose a peak is found on the top of the mast (4,0 m) when measuring the EUT, (see figure 14), giving a measurement distance of 3,91 m. For the substitution measurement however the test antenna peaks at 1,5 m giving a measurement distance of 3,0 m. A graph is provided (see figure A7 of TR 102 273-1-2 [9]) for obtaining the correction to be applied.

There is, however, an uncertainty associated with this correction factor:

u_{j18} is used for the uncertainty contribution associated with the calculated correction factor for the measurement distance.

5.4.2 Antenna mast, turntable and mounting fixtures

As the turntable and mounting fixtures are in close proximity to the EUT/antenna they can significantly change its performance. The antenna mast likewise for the test antenna. The antenna mast, turntable and mounting fixtures should, therefore, be constructed from non conducting, low relative dielectric constant plastics or wood to reduce reflections and interactions. Where wood is used, nails should not be used to join the sections - they should be jointed and glued. Table 4 gives examples of popularly used construction materials. It is recommended that materials with dielectric constants of less than 1,5 be used for all supporting structures.

Table 4: Dielectric data of constructional materials

Material	Dielectric constant	Frequency
Fibre Glass	4,8	100 MHz
Dry Oak	4,2	1 MHz
Douglas Fir	1,82	3 000 MHz
Balsawood	1,22	3 000 MHz
Polystyrene Foam	1,03	3 000 MHz
PTFE	2,1	3 000 MHz
Nylon	2,73	3 000 MHz

Wooden constructions needs to be protected, by some surface coating, from absorbing moisture. Either varnish or paint finishes can be used, but care should be exercised in selection so that low dielectric constant, low conductivity types are applied in order to minimize reflections.

The mast should be strong enough to raise and lower the antenna, its mount and feed cable. Its stability is an important aspect, particularly when the antenna is raised and lowered since it should do so in a straight vertical line. The rigidity of the antenna mast needs to be sufficient to prevent any angular errors in the pointing direction of the mounted antenna, in either horizontal or vertical planes, whatever load is placed on it. Should the mast twist and the antenna's boresight be directed away from the EUT, then, unless the antenna's pattern is omni-directional in the horizontal plane, there will be an uncertainty in signal level (see figure 16). Similarly, should the antenna be deflected in the vertical plane, unless the pattern is omni-directional in that plane, the beam will either nod towards the ground (thereby increasing the ground illumination), or tilt upwards reducing the signal level directed at the EUT. This deflection will also change the measurement distance and additionally change the relative phasing of the direct and reflected signals (see figure 17).

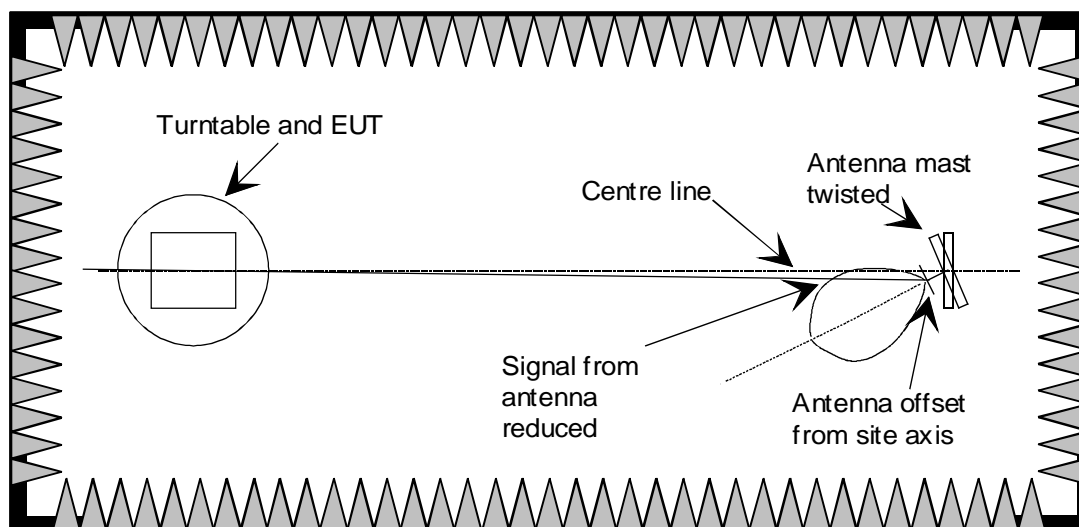
**Figure 16: Signal reduction due to a twisted mast (plan view)**

Accurate vertical positioning of the antenna is also important. The antenna supports should provide repeatable positioning and the limits of the weight capacities should not be exceeded. The stability of the turntable is important since an unstable, or non uniform turntable will also affect the measurement distance.

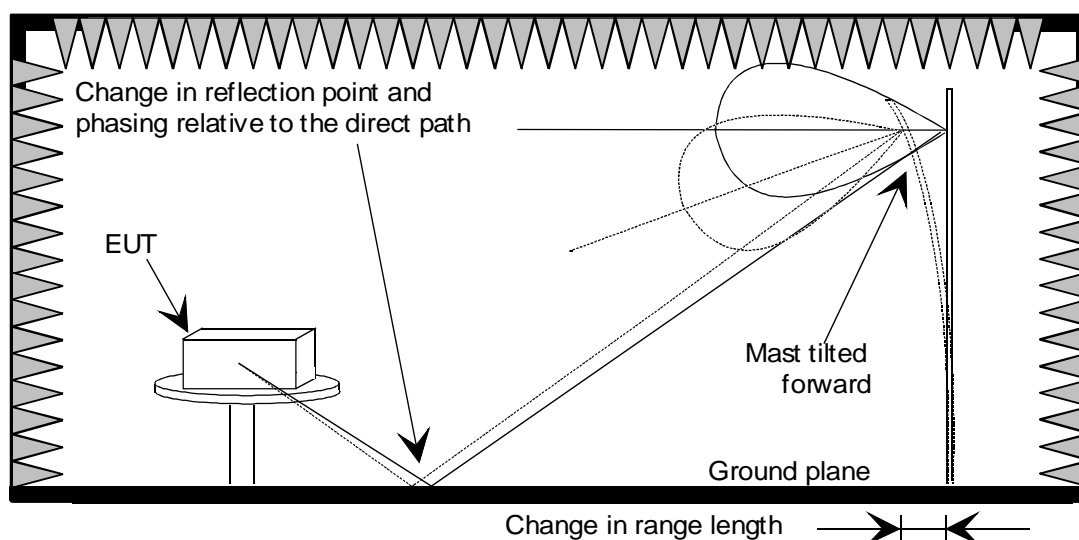

Figure 17: Mast stability

Controllers for both the mast and turntable should be carefully considered to minimize measurement uncertainties. For example, rapid changes in height or speed of rotation can lead to missing peak values. Settling times are important for measuring equipment. The controllers should, therefore, be designed with fixed, acceptable speeds which avoid these problems.

5.4.3 Test antenna height limitations

All tests on ground reflection sites are carried out so that the peak signal level is detected by varying the height of the test antenna on the mast. For an EUT with an omni-directional pattern in the vertical plane above a **perfectly** conducting ground, theoretically, this peak for vertical polarization occurs on the surface of the ground plane. It is difficult to measure this precise peak with an antenna of any finite size although a fixed monopole mounted on the ground plane could be used. Practically, this is not a viable solution and the antenna therefore has to be moved up the mast until the next peak in the vertical plane is located. With an upper limit of 4 m, the lowest frequency at which this next peak will appear on the mast is only achieved when the length of the reflected path is one wavelength longer than the direct path.

The situation regarding tests involving horizontal polarization is different since the phase of the ground reflection dictates a null appearing on the surface of the ground plane. To achieve a first peak on the mast for horizontal polarization therefore, the path difference between direct and reflected rays has only to be half a wavelength. Table 5 shows the lowest frequencies for different range lengths at which the difference in path lengths produces a peak on a mast offering a 1 m to 4 m height scan.

Table 5: The lowest frequency at which a peak appears against range length

Range length (m)	Lowest frequency at which a peak appears on the 4 m mast (Vertical polarization)	Lowest frequency at which a peak appears on the 4 m mast (Horizontal polarization)
3,0	127,1 MHz	63,6 MHz
5,0	162,8 MHz	81,4 MHz
10,0	271,5 MHz	135,8 MHz
30,0	757,5 MHz	378,8 MHz

NOTE: The frequencies given are, to an extent, dependant on the directivity of the antennas, but they are valid for the general case over a perfectly conducting ground plane. If the ground plane is not a perfect conductor these frequencies will differ.

Taking the other extreme, when the source has high directivity (e.g. waveguide horn) and the angle of its first null (in the vertical plane) coincides with the angle of the reflected ray, the height of the maximum peak on the mast will be at the height of the source itself (usually 1,5 m) irrespective of polarization.

5.4.4 Test antenna cabling

There are radiating mechanisms by which RF cables can introduce uncertainties into radiated measurements:

- leakage;
- acting as a parasitic element to an antenna;
- introducing common mode current to the balun of an antenna.

Leakage allows electromagnetic coupling into the cables. Because the electromagnetic wave contains both electric and magnetic fields, mixed coupling can occur and the voltage induced is very dependant on the orientation, with respect to the cable, of the electric and magnetic fields. This coupling can have different effects depending on the length of the cable and where it is in the system. Cables are usually the longest part of the test equipment configuration and as such leakage can make them act as efficient receiving or transmitting antennas thereby contributing significantly to the uncertainty of a measurement.

The parasitic effect of the cable can potentially be the most significant of the three effects and can cause major changes to the antenna's radiation pattern, gain and input impedance. The common mode current problem has similar effects on the antenna's performance.

All three effects can be largely eliminated by routeing and loading the cables with ferrite beads as detailed in the test methods. A cable for which no precautions have been taken to prevent these effects can cause different results to be obtained simply by being repositioned.

u_{j19} is used for the uncertainty contribution associated with cable factor (the combined uncertainty which results from interaction between any antenna and its cable).

5.4.5 EUT cabling

EUT cable layout can contribute significantly to the uncertainty of the measurement. Large variations can occur when measuring spurious emissions for example, as a result of the positions of the supply and control cables.

These cables can act as parasitic elements and can receive radiated fields. The effects vary with cable type, the configuration and use, but they may strongly influence the outcome of a measurement. A number of schemes can be used to reduce these problems, amongst which are a total replacement by fibre optic cables and twisting wires together and loading them with ferrite beads.

u_{j55} is used for the uncertainty contribution which results from interaction between the EUT and the power leads.

5.4.6 Positioning of the EUT and antennas

The phase centre of an EUT or an antenna is the point within the EUT or antenna from which it radiates. If the EUT or antenna was rotated about this point, the phase of the received/transmitted signal would not change. For some test procedures, especially those which require an accurate knowledge of the measurement distance, it is vital to be able to identify the phase centre.

Where an EUT is being tested the uncertainty in the position of the phase centre of the source within the EUT volume can lead to signal level uncertainties since all calculations deriving emission levels will be based on the precise measurement distance.

u_{j20} is used for the uncertainty contribution associated with not knowing the exact position of the phase centre within the EUT volume in test methods.

The positioning, on the turntable, of the phase centre of the EUT's radiating source, can lead to uncertainties if it is offset from the table's axis of rotation. Any offset will cause the source to describe a circle about the axis as the EUT is rotated. Variations in path lengths (both direct and reflected) are thereby introduced leading directly to changes in the received/transmitted field strength.

u_{j21} is used for the uncertainty contribution associated with the positioning of the phase centre within the EUT over the axis of rotation of the turntable in test methods.

Dipoles and bicones have phase centres at their feed points, whilst that for a waveguide horn is in the centre of its open mouth. The phase centres do not change with frequency for these antennas.

u_{j22} is used for the uncertainty contribution associated with the position of the phase centre of the measuring, substitution, receiving, transmitting or test antenna.

Certain antennas, most notably the LPDA, possess a phase centre which is difficult to pin point at any particular frequency. Further, for this type of antenna the phase centre moves along the array with changing frequency resulting in a measurement distance uncertainty (e.g. an LPDA with a 0,3 m length contributes a standard uncertainty level due to range length uncertainty of $u_j = 1,0$ dB). To use such an antenna for site verification, for example, could introduce large uncertainties.

u_{j23} is used for the uncertainty contribution associated with the position of the phase centre for LPDAs.

6 Verification procedure for an Anechoic Chamber with a Ground Plane

6.1 Introduction

The verification procedure is a process carried out in Anechoic Chambers with Ground Planes, fully Anechoic Chambers, Open Area Test Sites and Striplines to prove their suitability as free field test sites.

Anechoic Chambers and Open Area Test Sites

For both types of Anechoic Chamber (i.e. both with and without a ground plane) and Open Area Test Sites the verification procedure involves the transmission of a known signal level from one calibrated antenna (usually a dipole) and the measurement of the received signal level in a second calibrated antenna (also usually a dipole).

By comparison of the transmitted and received signal levels, an "insertion loss" can be deduced. After inclusion of any correction factors relevant to the measurement, the figure of loss which results from the verification procedure, is known as "site attenuation".

Site attenuation is defined in [11] as: "The ratio of the power input of a matched, balanced, lossless, tuned dipole radiator to that at the output of a similarly matched, balanced, lossless, tuned dipole receiving antenna for specified polarization, separation and heights above a flat reflecting surface. It is a measure of the transmission path loss between two antennas".

As the definition states "... above a flat reflecting surface", it is usual for the verification procedure to involve one antenna (the transmitting antenna) remaining fixed in height whilst a second antenna (the receiving antenna) is scanned through a specified height range looking for a peak in the received signal level.

The determination of site attenuation involves two different measurements of received signal level. The first is with all the items of test equipment connected directly together via an adapter, whilst the second involves the coaxial cables being connected to the antennas. The difference in received levels (after allowance for any relevant correction factors which may be appropriate), for the same signal generator output level, is the site attenuation.

The verification procedure for an Anechoic Chamber with a Ground Plane is based on EN 50147-2 [7] which itself is based on that given in CISPR 16-1 [6], clauses 15.4 to 16.6.3 inclusive. Both procedures call for the determination of Normalized site attenuation (NSA) which is equivalent to site attenuation after subtraction of the antenna factors. It should be noted that both publications EN 50147-2 [7] and CISPR 16-1 [6] only detail verification procedures in the 30 MHz to 1 000 MHz frequency band.

It is particularly for the verification of Open Area Test Sites that NSA has historically found use. However, the same approach has also been adopted in the verification procedure which follows for Anechoic Chambers with Ground Planes.

6.2 Normalized site attenuation

NSA is determined from the value of site attenuation by subtraction of the antenna factors and mutual coupling effects. The subtraction of the antenna factors makes NSA independent of antenna type.

NOTE: The uncertainty of the resulting value for NSA depends directly on the uncertainty with which the antenna factors are known.

Symbolically,

$$NSA = V_{direct} - V_{site} - AF_T - AF_R - AF_{TOT} \quad (6.1)$$

where:

V_{direct} = received voltage for cables connected via the "in-line" adapter;

V_{site} = received voltage for cables connected to the antennas;

AF_T = antenna factor of the transmit antenna;

AF_R = antenna factor of the receive antenna;

AF_{TOT} = mutual coupling correction factor.

The verification procedure compares the measured NSA (after relevant corrections) against the theoretical figure calculated for an ideal Anechoic Chamber with a Ground Plane. The difference between the two values at any specific frequency is a measure of the quality of the Chamber at that frequency.

In general, ANSI and CISPR consider a test site suitable for making measurements (both relative and absolute) if the measured NSA differs by less than ± 4 dB (throughout the entire frequency range) from the theoretical values.

The relevant theory for deriving the NSA of an ideal Anechoic Chamber with a Ground Plane is given below and begins with analysis of an Anechoic Chamber whose six internal surfaces are covered with absorbing material.

6.2.1 Anechoic Chamber

In an ideal Anechoic Chamber where there are:

- no unwanted reflections (ground reflected or others);
- no interaction between transmit and receive dipoles;
- no coupling of the dipoles to the absorbing material;
- and where perfectly aligned, loss-less, matched tuned dipoles are used.

The coupling between the dipoles (which are assumed to be half wavelength) is given by the Friis transmission equation (as derived in TR 102 273-1-1 [8]):

$$P_{rec} = \left(\frac{\lambda}{4\pi d}\right)^2 1,643^2 \left(\frac{\cos\left(\frac{\pi}{2}\cos\theta\right)}{\sin\theta}\right)^2 \left(\frac{\cos\left(\frac{\pi}{2}\cos\theta\right)}{\sin\theta}\right)^2 P_t \quad (6.2)$$

where:

P_t = power transmitted (W);

P_{rec} = power received (W);

λ = wavelength (m);

d = distance between dipoles (m),

and θ is a spherical co-ordinate, as shown in figure 18.

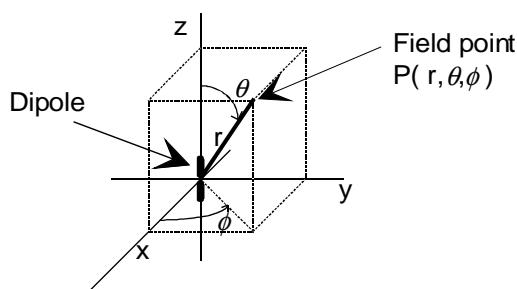

Figure 18: Spherical co-ordinates

For this ideal site, the site attenuation (the inverse of the Friis transmission equation) is given by:

$$\frac{P_t}{P_{rec}} = \left(\frac{4\pi d}{\lambda}\right)^2 \frac{1}{1,643^2} \left(\frac{\sin \theta}{\cos\left(\frac{\pi}{2} \cos \theta\right)}\right)^2 \left(\frac{\sin \theta}{\cos\left(\frac{\pi}{2} \cos \theta\right)}\right)^2 \quad (6.3)$$

More usually, this formula is given in logarithmic terms as follows:

$$\text{Site Attenuation} = 17,67 + 20 \log\left(\frac{d}{\lambda}\right) + 20 \log\left(\frac{\sin \theta}{\cos\left(\frac{\pi}{2} \cos \theta\right)}\right) + 20 \log\left(\frac{\sin \theta}{\cos\left(\frac{\pi}{2} \cos \theta\right)}\right) \text{ dB} \quad (6.4)$$

Since both transmit and receive antennas are assumed to be at the same height, $\theta = \pi/2$ and the formula reduces to:

$$\text{Site Attenuation} = 17,67 + 20 \log(d/\lambda) \text{ dB} \quad (6.5)$$

NOTE 1: In an actual measurement, the value of site attenuation is likely to be greater than given by this formula due to mismatch and resistive losses, mutual coupling effects, etc.

An alternative formulation for site attenuation, based on field strength (V/m) and antenna factors has been derived in [3]. The resulting formulae are for use with ground reflection sites but they are easily adapted for the fully Anechoic Chamber.

The general formula given in [3] for site attenuation, A , is:

$$A = \frac{279,1 AF_T AF_R}{f_m E_{D(H \text{ or } V)}^{\max}} \quad (6.6)$$

where:

AF_T = antenna factor of the transmitting antenna (m^{-1});

AF_R = antenna factor of the receiving antenna (m^{-1});

f_m = frequency (MHz) and;

$E_{D(H \text{ or } V)}^{\max}$ = calculated maximum electric field strength ($\mu\text{V}/\text{m}$) in the receiving antenna height scan from a half wavelength dipole with 1 pW of radiated power.

$E_{D(H \text{ or } V)}^{\max}$ takes the form E_{DH}^{\max} for horizontal polarization and E_{DV}^{\max} for vertical polarization.

NOTE 2: The stipulations of a half wavelength dipole and 1 pW of radiated power in $E_{D(H \text{ or } V)}^{\max}$ do not limit the use of the site attenuation equation to those conditions. The definition of $E_{D(H \text{ or } V)}^{\max}$ in the text of [3] is for convenience only and the stipulated conditions cancel out in the final formulae for site attenuation and NSA, both of which apply generally.

For the fully Anechoic Chamber, $E_{D(H \text{ or } V)}^{\max}$ (a term whose amplitude is generally peaked on a ground reflection range by height scanning on a mast) is simply replaced by $E_{D(H \text{ or } V)}$ since no maximization is involved and both polarizations behave similarly. $E_{D(H \text{ or } V)}$ can be shown to be:

$$E_{DH} = E_{DV} = 7,01/d \quad (6.7)$$

In decibel terms, the site attenuation formula becomes:

$$A = 48,92 + 20 \log (AF_T) + 20 \log (AF_R) - 20 \log f_m - 20 \log (7,01/d) \text{ dB} \quad (6.8)$$

The formula for NSA then follows as:

$$\text{NSA} = A - 20 \log (AF_T) - 20 \log (AF_R) \text{ dB} \quad (6.9)$$

i.e. $\text{NSA} = 48,92 - 20 \log f_m - 20 \log (7,01/d) \text{ dB}$

6.2.2 Anechoic Chamber with a Ground Plane

The formula for $E_{D(H \text{ or } V)}$ in the site attenuation equation for the fully Anechoic Chamber, given above, is only applicable if no reflections (ground or otherwise) are present. For the Anechoic Chamber with a Ground Plane the formula has to be modified to take the ground reflection into account. However, this situation is further complicated by:

- the ground reflected ray suffering a phase reversal at the metal/air boundary for the horizontally polarized case (vertically polarized signals suffer no phase change); and
- the radiation pattern of the dipole, (which is omni-directional in the H-plane and directional in the E-plane), resulting in received amplitudes which change with off-boresight angles in the E-plane for vertical polarization. This does not occur in the horizontally polarized case.

As a result different formulae apply for horizontal and vertical polarizations and these are now derived. For both polarizations however, the basic formula for site attenuation remains as:

$$A = \frac{279,1 AF_T AF_R}{f_m E_{D(H \text{ or } V)}^{\max}} \quad (6.10)$$

For the horizontal polarized case of this formula, the term $E_{D(H \text{ or } V)}^{\max}$ in an ideal Anechoic Chamber with a Ground Plane using dipoles and optimized over the height scan range, is [3]:

$$E_{DH}^{\max} = \frac{7,01}{d_{dir} d_{refl}} \sqrt{d_{refl}^2 + |\rho_H|^2 d_{dir}^2 + 2d_{dir} d_{refl} |\rho_H| \cos(\phi_H - \beta(d_{refl} - d_{dir}))} \quad (6.11)$$

where:

$$\rho_H = \frac{\sin \gamma - (K - j60\lambda\sigma - \cos^2 \gamma)^{\frac{1}{2}}}{\sin \gamma + (K - j60\lambda\sigma - \cos^2 \gamma)^{\frac{1}{2}}} = |\rho_H| e^{j\phi_H} ;$$

d_{dir} = path length of the direct signal (m); d_{refl} = path length of the reflected signal (m);

β = $2\pi/\lambda$ (radians/m); K = relative dielectric constant;

σ = conductivity (Siemens/m); ϕ_H = phase angle of reflection coefficient;

γ = incidence angle with ground plane.

For a perfectly reflecting metallic ground plane, $|\rho_H|=1,0$ and $|\phi_H|=180^\circ$. As a result, the formula for E_{DH}^{\max} reduces to:

$$E_{DH}^{\max} = \frac{7,01 \sqrt{d_{refl}^2 + d_{dir}^2 - 2d_{dir}d_{refl} \cos \beta (d_{refl} - d_{dir})}}{d_{dir}d_{refl}} \quad (6.12)$$

Figure 19 shows the geometry for horizontally polarized tests using dipoles above a reflecting surface.

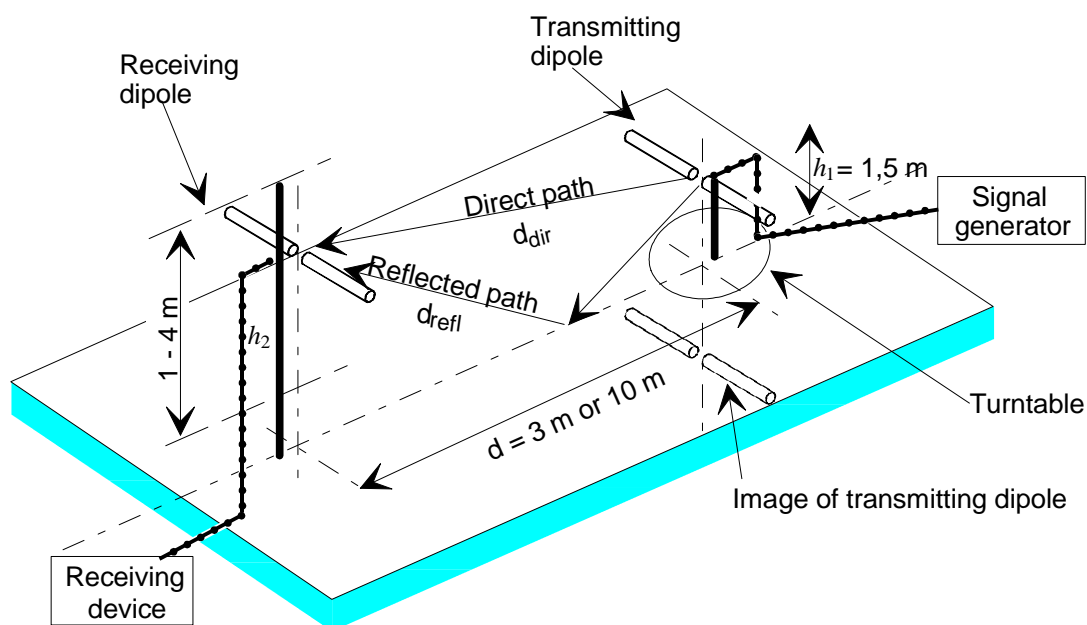

Figure 19: Ground reflection test site layout for horizontally polarized verification using dipoles

From figure 19 it can be seen that:

$$d_{dir} = \sqrt{(h_2 - h_1)^2 + d^2} \quad \text{and} \quad d_{refl} = \sqrt{(h_1 + h_2)^2 + d^2} \quad (6.13)$$

For vertical polarization, a similar procedure is used to find E_{DV}^{\max} . However, in the vertical case, off boresight angles of incidence, shown in figure 20 introduce additional terms.

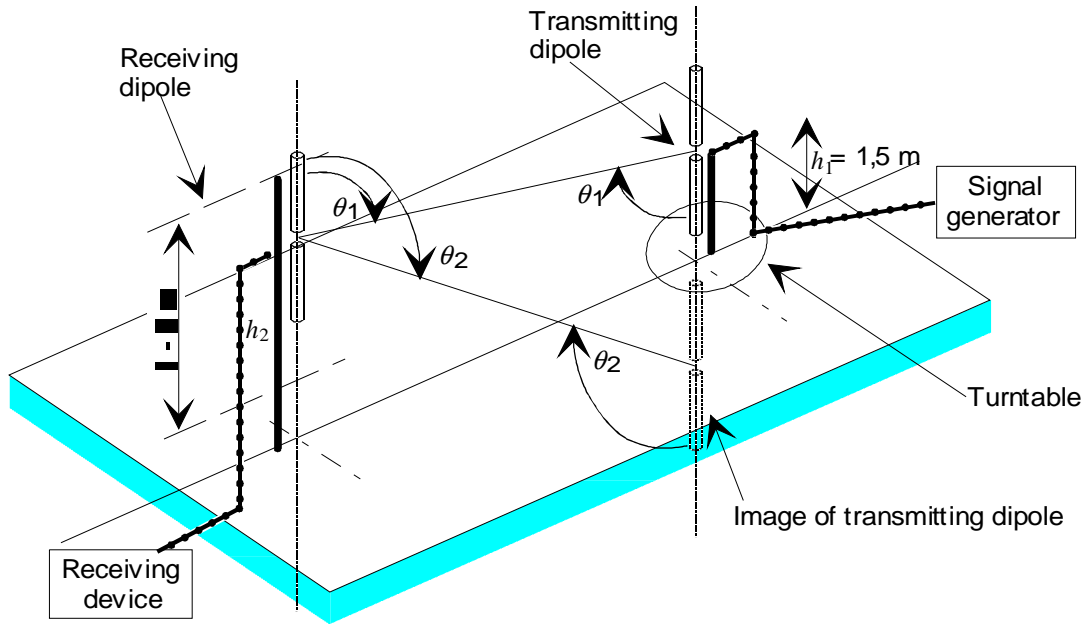

Figure 20: Off-boresight angles involved in verification using vertical polarization

This off boresight angle effect is accounted for in [3] by giving the dipoles a "sin θ " pattern in the E-plane (the vertical plane as shown in figure 20).

Geometrically,

$$\sin \theta_1 = \frac{d}{d_{dir}} \quad \text{and} \quad \sin \theta_2 = \frac{d}{d_{refl}} \quad (6.14)$$

and incorporating these into the calculation of E_{DV}^{\max} , optimized over the height scan range, produces:

$$E_{DV}^{\max} = \frac{7,01 d^2}{d_{dir}^3 d_{refl}^3} \sqrt{d_{refl}^6 + d_{dir}^6 |\rho_V|^2 + 2 d_{dir}^3 d_{refl}^3 |\rho_V| \cos(\phi_V - \beta(d_{refl} - d_{dir}))} \quad (6.15)$$

where:

$$\rho_V = \frac{(K - j60\sigma) \sin \gamma - (K - j60\lambda\sigma - \cos^2 \gamma)^{\frac{1}{2}}}{(K - j60\sigma) \sin \gamma + (K - j60\lambda\sigma - \cos^2 \gamma)^{\frac{1}{2}}} = |\rho_V| e^{j\phi_V}$$

For a perfectly reflecting metallic ground plane, $|\rho_V| = 1,0$ and $\phi_V = 0^\circ$. As a result, the formula for E_{DV}^{\max} reduces to:

$$E_{DV}^{\max} = \frac{7,01 d^2}{d_{dir}^3 d_{refl}^3} \sqrt{d_{refl}^6 + d_{dir}^6 + 2 d_{dir}^3 d_{refl}^3 \cos \beta(d_{refl} - d_{dir})} \quad (6.16)$$

It is important, on ground reflection sites, to state again that the received signal level needs to be peaked by varying the height of the receive antenna on the antenna mast (usually from 1 m to 4 m) for these formulae to be used correctly.

6.2.3 Improvements to the formulae for E_{DH}^{\max} and E_{DV}^{\max}

In the verification procedure for an Anechoic Chamber with a Ground Plane, the performance is measured for a number of transmitting dipole positions within a specified volume. This results in several positions for which off-boresight angles of incidence occur. As a consequence, the formula for E_{DH}^{\max} has to be modified. However, so too does E_{DV}^{\max} since the angles involved are no longer simple as considered above but are compound.

Further modifications to the formulae for E_{DH}^{\max} and E_{DV}^{\max} have also been made to more accurately represent the patterns of the dipoles. A better approximation to the nearly half wavelength dipoles of

$$\frac{\cos\left(\frac{\pi}{2}\cos(\theta)\right)}{\sin\theta} \quad (6.17)$$

has been used, resulting in the following formulae.

For horizontal polarization:

$$E_{DH}^{\max} = \frac{7,01}{YZ} \sqrt{d_{dir}^2 Z^2 \cos^4 \alpha_1 + d_{refl}^2 Y^2 \cos^4 \alpha_2 - 2d_{dir}d_{refl}YZ \cos^2 \alpha_1 \cos^2 \alpha_2 \cos \beta (d_{refl} - d_{dir})} \quad (6.18)$$

where:

$$\alpha_1 = \frac{\pi}{2} \frac{y_{offset}}{d_{dir}} \text{ (radians), where } y_{offset} \text{ is given in figure 21;}$$

$$\alpha_2 = \frac{\pi}{2} \frac{y_{offset}}{d_{refl}} \text{ (radians);}$$

$$Y = d_{dir}^2 - y_{offset}^2 \text{ (m}^2\text{);}$$

$$Z = d_{refl}^2 - y_{offset}^2 \text{ (m}^2\text{).}$$

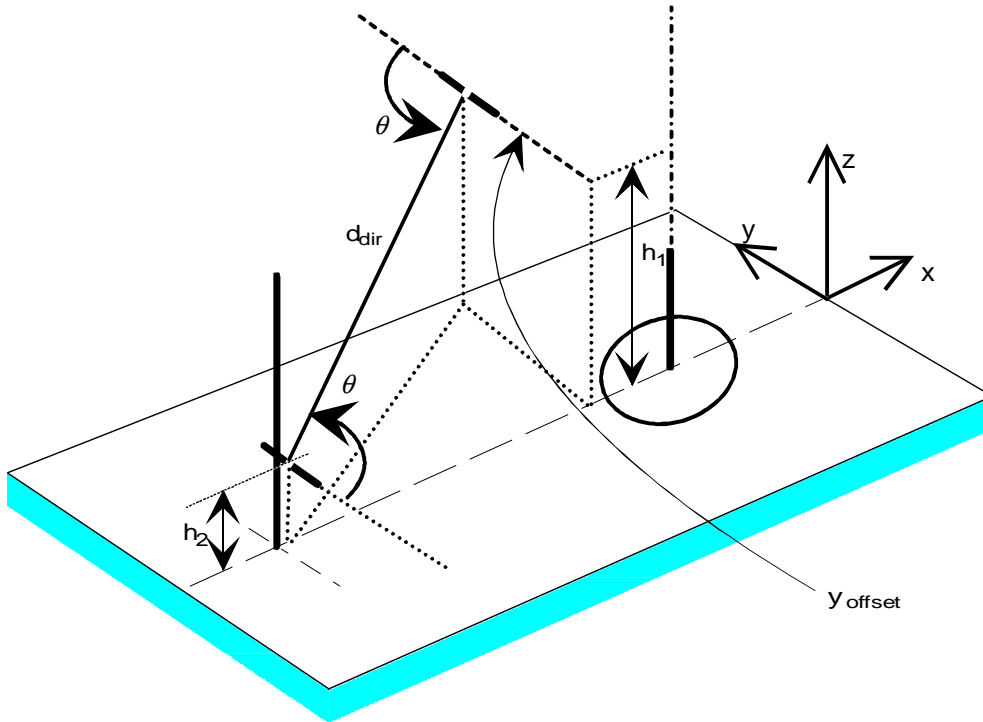

Figure 21: Geometry of the verification set-up for horizontal polarization

For vertical polarization, a similar procedure results in:

$$E_{DV}^{\max} = \frac{7,01}{D} \sqrt{d_{dir}^2 \cos^4 \delta_1 + d_{refl}^2 \cos^4 \delta_2 + 2d_{dir}d_{refl} \cos^2 \delta_1 \cos^2 \delta_2 \cos \beta (d_{refl} - d_{dir})} \quad (6.19)$$

where:

$$\delta_1 = \frac{\pi}{2} \frac{(h_2 - h_1)}{d_{dir}} \text{ (radians); } \delta_2 = \frac{\pi}{2} \frac{(h_2 + h_1)}{d_{refl}} \text{ (radians);}$$

and $D = d^2 + y_{offset}^2$ (m²).

To derive NSA, these figures (maximized within the height scan limits) are inserted into:

$$NSA = 20 \log \left(\frac{279,1}{f_m E_{D(H \text{ or } V)}^{\max}} \right) \text{ dB} \quad (6.20)$$

i.e.: $NSA = 48,92 - 20 \log f_m - 20 \log E_{D(H \text{ or } V)}^{\max}$ dB

It is this formula for NSA which has been used to calculate the performance of an ideal Anechoic Chamber with a Ground Plane against which the measured results of the verification procedure are compared.

6.2.4 Mutual coupling

Mutual coupling may exist between the antennas during the verification procedure. This will serve to modify the results since it can change input impedance/voltage standing wave ratio, radiation patterns and gain/antenna factors of both dipoles.

Figure 22 shows schematically mutual coupling as it occurs between dipoles in a reflection-free environment (i.e. an ideal Anechoic Chamber).

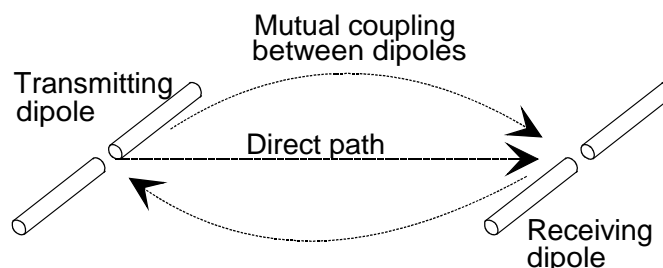

Figure 22: Direct path and mutual coupling

The situation is more complex for an Anechoic Chamber with a Ground Plane, since the ground plane acts like a mirror, imaging each dipole in the ground. Because of this imaging there are, in effect, four dipoles to be considered. The transmitting dipole "sees" its own image in the ground as well as the real receiving dipole and its image. Similarly, the receiving dipole "sees" its own image in the ground along with the transmitting dipole and its image. Mutual coupling can exist between all these dipoles, whether real or imaginary. This is shown in figure 23b alongside the ideal model in figure 23a.

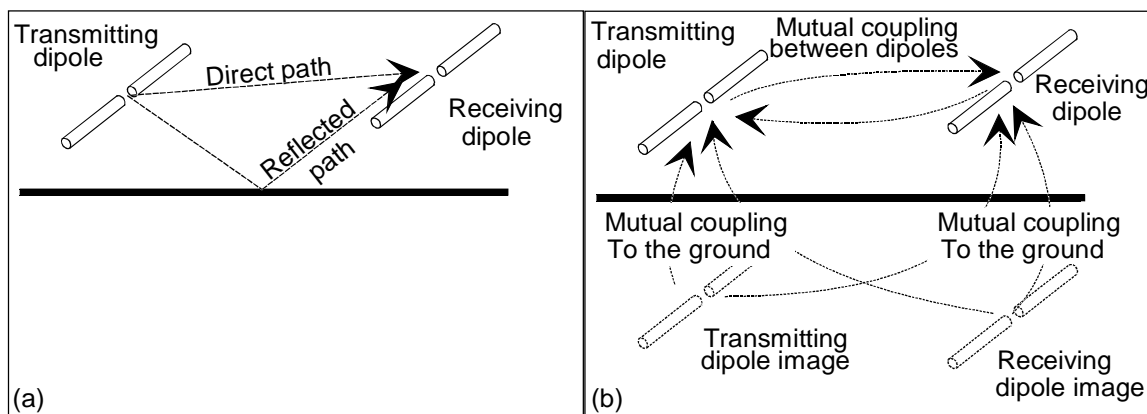

Figure 23: (a) Ideal model of a ground reflection site and (b) Mutual coupling effects on a real site

A further complication is that for fixed geometry's the mutual coupling effects vary with frequency. The actual situation when horizontally polarized NSA is measured is shown schematically in figure 24.

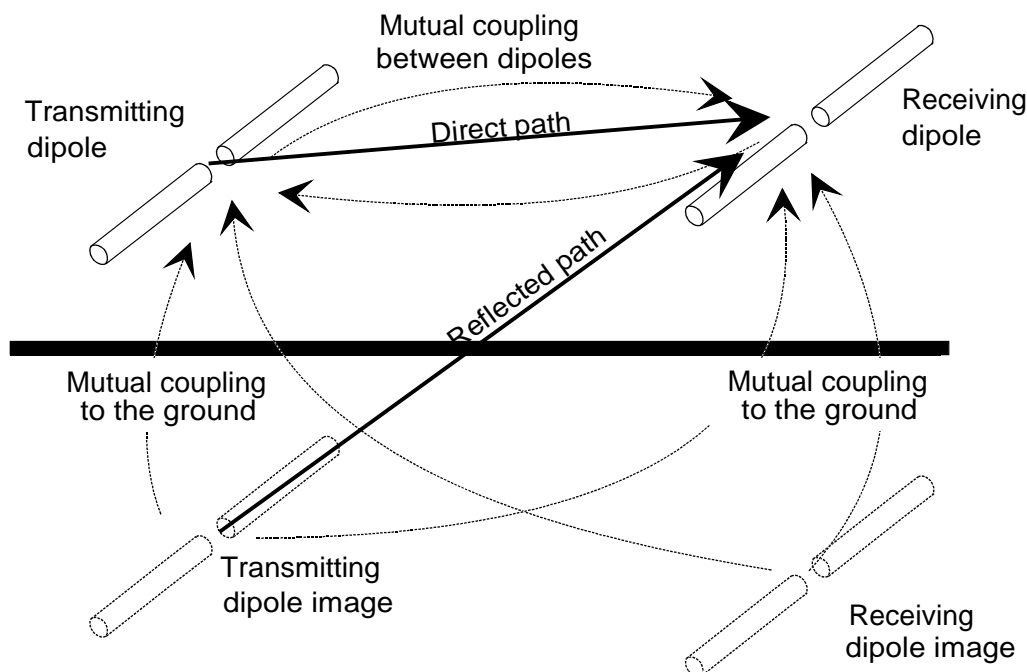

Figure 24: Mutual coupling during a NSA measurement

For accurate determination of NSA these additional effects need to be taken into consideration and correction factors should be applied to the measured results to compensate.

In the verification procedure that follows, tables of correction factors are provided for mutual coupling between dipoles, where relevant, for 3 m and 10 m range lengths.

6.3 Overview of the verification procedure

The first steps in the verification procedure are the gathering of all the appropriate test equipment (see clause 6.3.1) and preparation of the site (see clause 6.3.2).

The test equipment should then be configured (see clause 6.3.3), and the verification procedure carried out (see clause 6.4).

On completion of the verification procedure, the results need to be processed (see clause 6.5) so that at each test frequency a value for the deviation of the chamber from the ideal can be calculated and plotted (see figure 35) and the measurement uncertainties calculated (see clauses 6.6 and 6.7).

The verification procedure (see clause 6.4) recommends an antenna scheme in the 30 MHz to 1 000 MHz frequency band which uses tuned, half wavelength dipoles for all frequencies in the range 80 MHz to 1 000 MHz and shortened dipoles (see clause 6.3.3) below 80 MHz.

NOTE: For cases in which this is not suitable, an alternative scheme using dipoles and bicones (possibly also LPDAs) is suggested in clause 6.4.2. It should be noted that measurement uncertainty is likely to be degraded if the recommended dipole scheme is not used.

For the 1 GHz to 12,75 GHz band, broadband antennas (LPDAs) are recommended.

Throughout the whole band of 30 MHz to 12,75 GHz, the procedure involves discrete frequencies only. For the frequency range 30 MHz to 1 000 MHz, the frequencies have been taken from CISPR 16-1 [6], annex G.

Figure 25 shows a typical verification testing arrangement of antennas (for the lower band) and test equipment.

In the following procedures, the position of the transmitting antenna is specified whilst the height of the receiving antenna is varied over 1 m to 4 m, so that the maximum received signal level is obtained. This maximum occurs when the direct signal and the signal reflected from the ground plane are in phase at the receiving antenna, or, in cases where this condition cannot be met, at the highest or lowest extremes of the height scan range.

The following verification procedures require the full 1 m - 4 m height scan range to be available - values given in the text for ideal received signal levels are only valid under this condition. Therefore if the full 4 m height is not available, the results of the verification procedure will not be valid and the procedure should not be carried out.

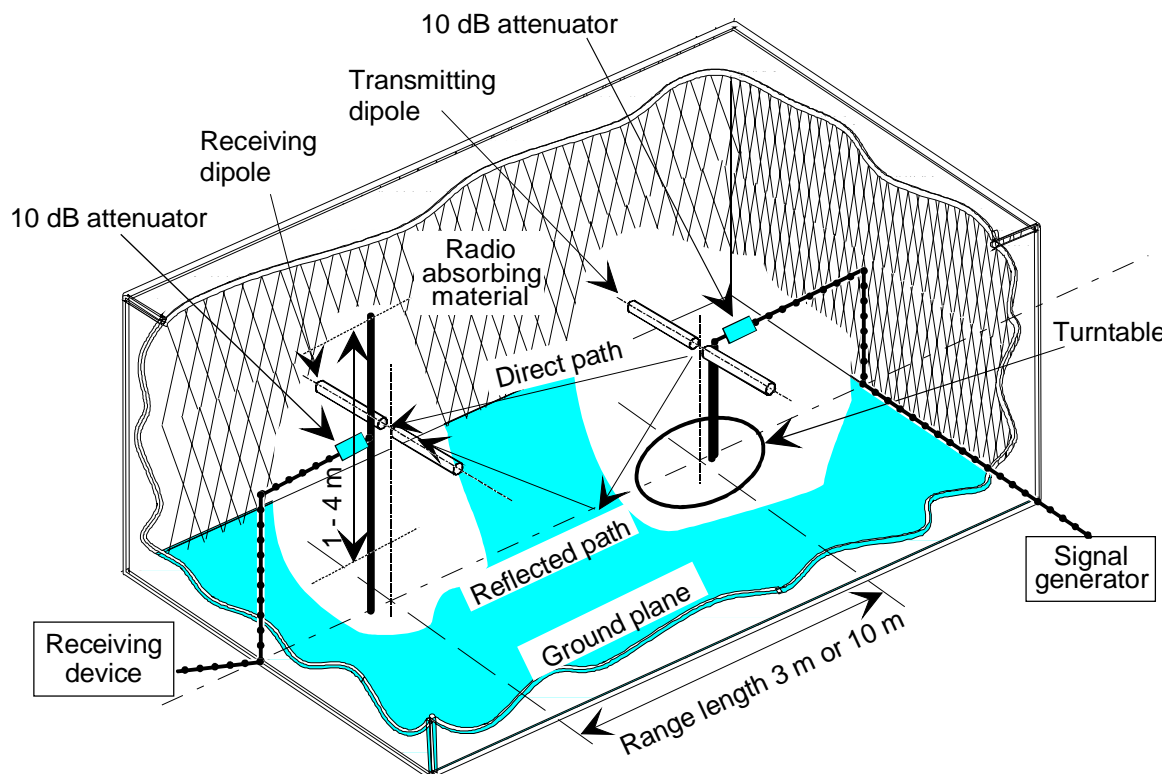

Figure 25: Site layout for the horizontally polarized verification procedure using dipoles in an Anechoic Chamber with a Ground Plane

6.3.1 Apparatus required

- attenuator pads, 10 dB;
- connecting cables;
- ferrite beads;
- receiving device (measuring receiver or spectrum analyser);
- signal generator;
- transmit antenna;
- receive antenna.

For frequencies from 30 MHz to 1 000 MHz:

- transmit antenna (half wavelength dipoles as detailed in ANSI C63.5 [1] recommended);
- receive antenna (half wavelength dipoles as detailed in ANSI C63.5 [1] recommended).

NOTE 1: Alternatively dipoles plus bicones or dipoles plus bicones and LPDAs may be used.

NOTE 2: The reference dipole antennas, incorporating matching/transforming baluns, for the procedure are available in the following bands: 20 MHz to 65 MHz, 65 MHz to 180 MHz, 180 MHz to 400 MHz, 400 MHz to 1 000 MHz. Constructional details are contained in ANSI C63.5 [1]. In the recommended antenna scheme for verification in this band, a shortened dipole is used at all frequencies from 30 MHz to 70 MHz inclusive.

For frequencies above 1 000 MHz:

- transmit antenna (LPDA 1 to 12,75 GHz);
- receive antenna (LPDA 1 to 12,75 GHz).

The type and serial numbers of all items of test equipment should be recorded in the results sheet relevant to the frequency band i.e. table 9 for the 30 MHz to 1 000 MHz band, table 10 for the 1 GHz to 12,75 GHz band.

6.3.2 Site preparation

Prior to the start of the verification procedure, system checks should be made on the equipment to be used. All items of test equipment, where appropriate, should be connected to power supplies, switched on and allowed adequate time to stabilize, as recommended by the manufacturers. Where a stabilization period is not given by the manufacturer, 30 minutes should be allowed.

The cables for both ends of the test chamber should be routed, where possible, parallel to or coincident with the plane of symmetry of the chamber (see figure 30) and parallel to the floor. They should run behind and away from the antennas towards the end walls for a minimum of 2 m (unless the end wall is reached). They should then be allowed to drop vertically towards the floor, preferably behind the anechoic panels, and routed out through the screen (normally via a breakout panel) to the test equipment.

These cables should be dressed with ferrite beads, spaced 0,15 m apart for their entire lengths above the ground plane. The cables, their routing and dressing should be the same as for the normal operation of the chamber.

NOTE: Where a cable drum is incorporated with the antenna mast, the routing requirement and ferrite beading of the cables may be impossible to comply with. In such cases increased measurement uncertainty results.

Calibration data for all items of test equipment should be available and valid. For all non-ANSI dipoles, the data should include VSWR and antenna factor (or gain) against frequency. The calibration data for all cables and attenuators should include insertion loss and VSWR throughout the entire frequency range of the tests. Where any correction factors/tables are required, these should be immediately available.

6.3.3 Measurement configuration

For the frequency band 30 MHz to 1 000 MHz, both antennas should be tuned half-wavelength dipoles (constructed as detailed in ANSI C63.5 [1] aligned for the same polarization.

NOTE 1: Due to size constraints a shortened dipole is used over part of this frequency band. For uniformity of verification procedure across Open Area Test Sites and both types of Anechoic Chamber, a shortened dipole is used from 30 MHz to 70 MHz inclusive. At all these frequencies the 80 MHz arm length (0,889 m) is used attached to the 20 MHz to 65 MHz balun for all test frequencies in the 30 MHz to 60 MHz band and to the 65 MHz to 180 MHz balun for 70 MHz. Tuned half wavelength dipoles, attached to their matching baluns are used for all frequencies in the band 80 MHz to 1 000 MHz inclusive. Table 6 details dipole arm lengths (as measured from the centre of the balun block) and balun type against frequency.

Table 6: Dipole arm length and balun type against frequency

Frequency (MHz)	Dipole arm length (m)	Balun type	Frequency (MHz)	Dipole arm length (m)	Balun type
30	0,889	20 MHz to 65 MHz	160	0,440	65 MHz to 180 MHz
35	0,889		180	0,391	
40	0,889		200	0,352	180 MHz to 400 MHz
45	0,889		250	0,283	
50	0,889		300	0,235	
60	0,889		65 MHz to 180 MHz	400	0,175
70	0,889	500		0,143	
80	0,889	600		0,117	
90	0,791	700		0,102	
100	0,714	800		0,089	
120	0,593	900		0,079	
140	0,508	1 000	0,076		

For both bands, the transmitting antenna is placed in 10 different positions for each polarization as shown in figures 26 and 27. Correction factors (where appropriate) and NSA data are supplied for all positions.

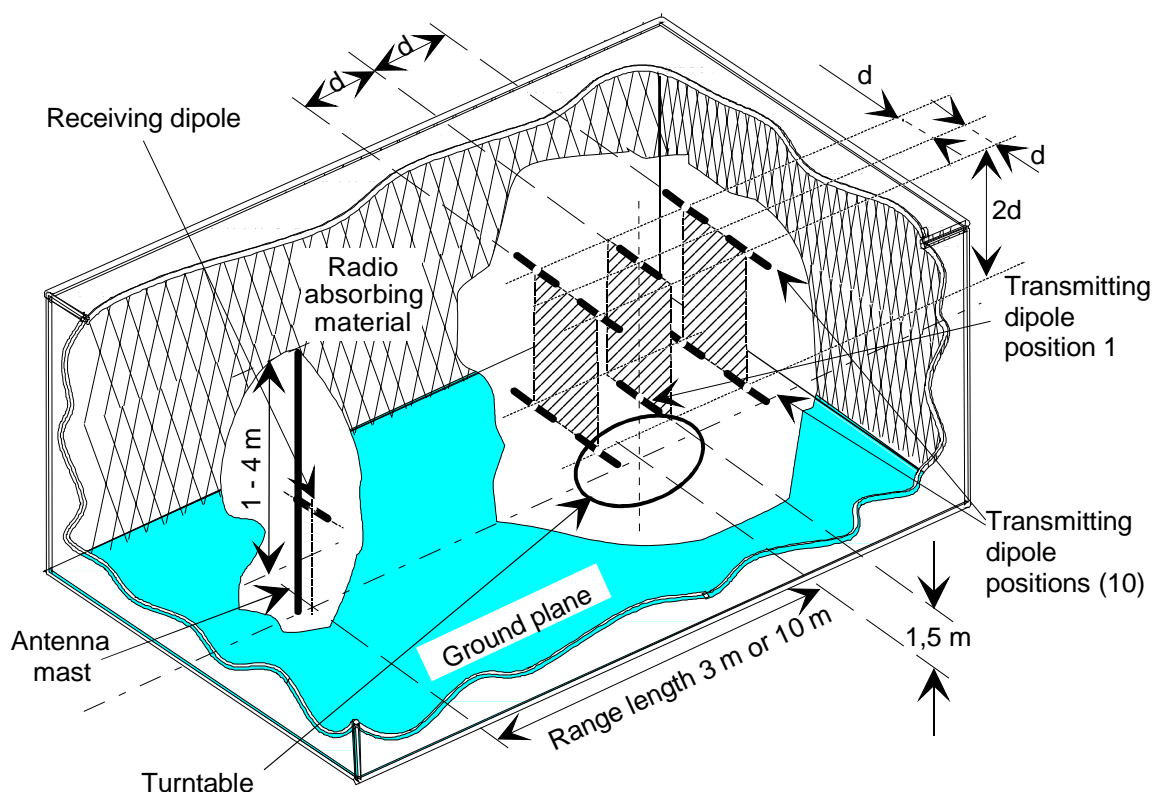

Figure 26: Antenna arrangements for horizontal polarization

Whilst figures 26 and 27 show the 30 MHz to 1 000 MHz scheme for dipoles, the same antenna positions/polarization scheme is used in the 1 GHz to 12,75 GHz band for which both antennas should be LPDAs.

NOTE 2: When the transmitting LPDA is used at positions other than in the central axis of the chamber, the transmitting and receiving antennas should be aligned in azimuth, but not in elevation (i.e. they should point directly towards each other keeping their long central axes parallel to the ground plane).

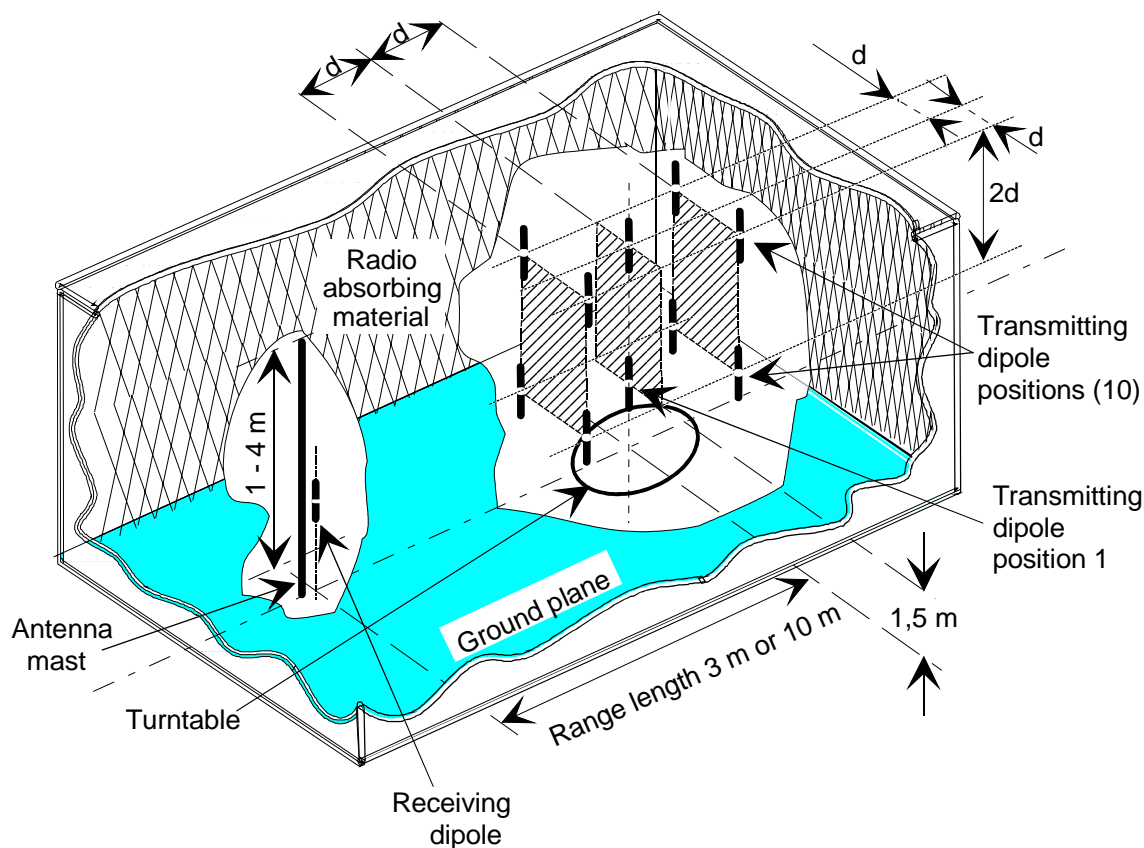

Figure 27: Antenna arrangements for vertical polarization

For both bands, the measured NSA is determined for all positions/polarizations.

6.3.4 What to record

During the course of the procedure the chamber ambient temperature and relative humidity should be recorded.

Also during the course of the procedure, the output level of the signal generator, the received level, the tuned frequency and polarization of the antennas should be recorded along with ALL equipment used - signal generator, receiver, cables, connectors, etc. An example of the results sheet is shown in table 7. A set of 20 results sheets, one corresponding to each position/polarization of the transmitting antenna, should be completed for each frequency band.

NOTE: The results sheet for 1,0 to 12,75 GHz verification (see table 10) is identical to table 7 except for renaming of the "Dipole height" column to "LPDA height" and the omission of the column for mutual coupling correction factor AF_{TOT} . Where LPDAs are used, no corrections for mutual coupling are necessary.

Table 7: Example of an Anechoic Chamber with a Ground Plane verification results sheet

Anechoic Chamber with a Ground Plane verification procedure results sheet 30 MHz to 1 000 MHz									
Range length: 3 m			Polarization: Horizontal			Date:			
Ambient temperature 20°C				Position Number 1		Relative humidity 60 %			
Freq. (MHz)	Direct V _{direct} (dBμV)	Dipole height (m)	Site V _{site} (dBμV)	Transmit Antenna factor AF _T (dB)	Receive Antenna factor AF _R (dB)	Mutual coupling correction AFTOT (dB)	Overall value (dB)	Ideal value (dB)	Difference (dB)
Transmit antenna: Dipole S/No. D 001					Receive antenna: Dipole S/No. D 002				
Transmit antenna cable: Ref. No. C 128					Receive antenna cable: Ref. No. C 129				
Signal generator: Ref. No. SG 001					Receiving device: Ref. No. SA 001				
Attenuator: S/No. AT 01					Attenuator: S/No. At 02				
Ferrite type: Worry beads					Ferrite manufacturer: Rusty co. Ltd.				

6.4 Verification procedure

Introduction

Two different procedures, one for each frequency band, are involved in verifying the performance of an Anechoic Chamber with a Ground Plane which is used for the band 30 MHz to 12,75 GHz. The first procedure covers 30 MHz to 1 000 MHz and the second covers 1 GHz to 12,75 GHz.

6.4.1 Procedure 1: 30 MHz to 1 000 MHz

Direct attenuation

- 1) The two antenna cables should be connected together, via attenuator pads and an "in-line" adapter as shown in figure 28. Alternatively, if this is not practical, a calibrated cable may be used instead of the adapter.

NOTE 1: The use of a cable will increase the expanded measurement uncertainty.

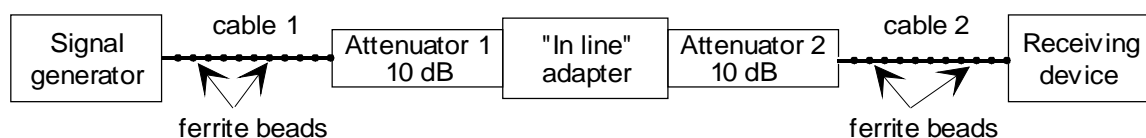

Figure 28: Initial equipment arrangement for the verification procedure

- 2) The output of the signal generator should be adjusted to an appropriate level. The minimum acceptable level for any frequency in the band of interest may be calculated from:
 - 20 dB above the maximum expected radiated path loss ($20 \log ((4\pi \text{ range length})/\lambda)$), plus the ambient noise floor, the value of the attenuator pads and the cable losses, minus the antenna gains.

NOTE 2: For practical purposes it is advisable to set a single output level for all frequencies in the band, since this avoids level changes during the verification. Therefore this calculation should be evaluated at 30 MHz, the worst frequency, since the reduced sensitivity of the shortened dipoles at this frequency requires an enhanced signal level 53 dB above that required for tuned half wavelength dipoles. Table 8 indicates the enhancement required for other frequencies where shortened dipoles are used.

EXAMPLE: $20 \text{ dB} + 22 \text{ dB (radiated path loss)} - 110 \text{ dBm (ambient noise floor)} + 20 \text{ dB (attenuator pads)} + 1 \text{ dB (cable losses)} - 4 \text{ dB (antenna gains)} + 53 \text{ dB (enhancement)} = + 2 \text{ dBm (109 dB}\mu\text{V)}$.

Table 8: Enhancement figures for shortened dipoles

Frequency (MHz)	Enhancement (dB)
30	53
35	48
40	43
45	38
50	32
60	19
70	4

If the calculated level is not available then the verification should not proceed.

Once set, this signal generator output level should not be adjusted again for the entire duration of the verification procedure.

- 3) The receiving device and signal generator should be tuned to the appropriate frequency (starting at the first frequency given in the results sheet shown in table 9). The output level of the signal generator should be checked (to be certain that the original set level has been maintained) and the received level on the receiving device should be noted. For each frequency, the value to be entered in the column headed "Direct" on the results sheet is the sum of this received level plus the loss of the "in-line" adapter or cable at this frequency i.e.:

- "Direct" value = received level + loss of "in-line" adapter or cable

- 4) Step 3 should be repeated for all the frequencies in the results sheet shown in table 9.

- Radiated attenuation: Horizontal polarization

- 5) The adapter used to make the direct connection between the attenuator pads should be removed and the transmit and receive dipoles connected as shown schematically in figure 29.

- 6) The signal generator, receiving device and dipoles should be tuned to the appropriate frequency (starting at the top of the results sheet shown in table 9).

NOTE 3: For all frequencies below 80 MHz, a shortened dipole (as defined in clause 6.3.3) should be used. The dipole arm length is defined as the measured distance from the centre of the balun used to the tip of the arm. From a fully extended state, each telescopic element, in turn, should be "pushed in" from the tip until the required length is obtained. The outermost section needs to fully compress before any of the others, and so on.

- 7) The receiving dipole should be mounted on the antenna mast and oriented for horizontal polarization. The mast should allow the height of the dipole above the ground plane to be varied between 1 m and 4 m, subject to the restrictions that no part of the antenna should be less than 1 m away from the absorbers and 0,25 m away from the ground plane. The procedure should not be carried out in facilities that cannot provide the full 1 m to 4 m height scan. The phase centre of the dipole should lie in the plane of symmetry of the chamber (see figure 30) and the axis of the centre should be parallel to the floor.
- 8) The range length (3 m or 10 m) is defined as the horizontal distance between the receiving dipole and the axis of rotation of the turntable. This should be set to an accuracy of $\pm 0,01$ m.
- 9) The transmitting dipole should be mounted in position 1 as shown in figures 26 and 31 and oriented for horizontal polarization. It should be positioned with its centre:
- 1,5 m above the ground plane;
 - in the plane of symmetry of the chamber (see figure 30);
 - on the axis of rotation of the turntable.

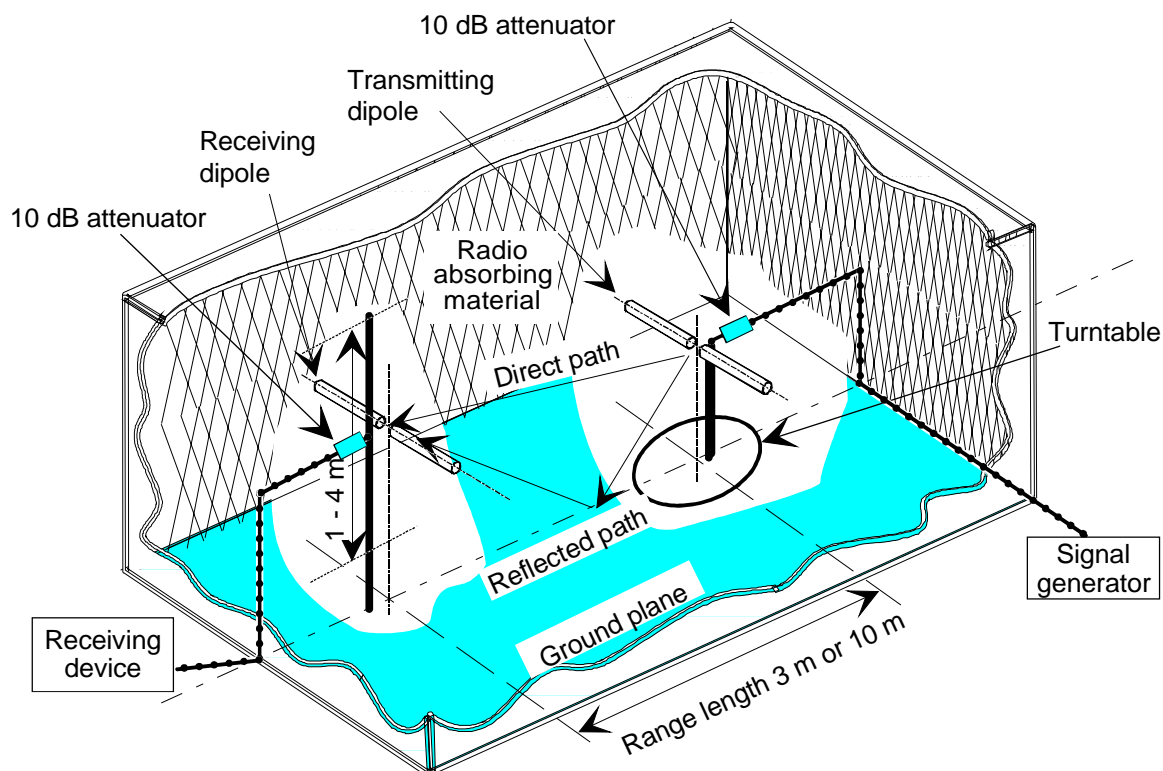

Figure 29: Equipment configuration for verification of the Anechoic Chamber with a Ground Plane

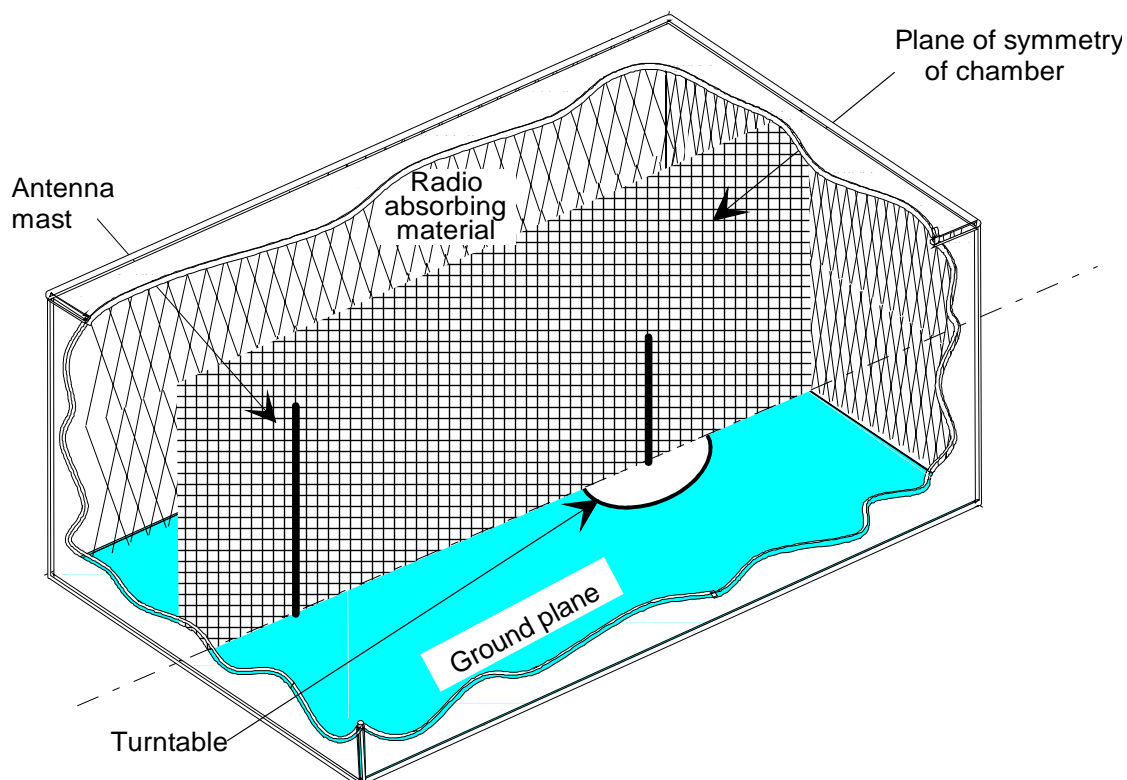

Figure 30: The plane of symmetry of the Anechoic Chamber with a Ground Plane

10) The position of the receiving dipole should be varied over the 1 m to 4 m height range whilst monitoring the level of received signal. The receiving dipole should then be positioned at the height of maximum received signal and the height recorded under "Dipole height" in the results sheet (see table 9).

NOTE 4: The true maximum may lie beyond the top of the mast, in which case the maximum receivable level will be at the top of the height range.

- 11) The output level of the signal generator should be checked (to ensure that an inadvertent change to the original set level has not occurred) and the received level on the receiving device should be noted. This value should be entered in the results sheet (see table 9) under the column headed "Site".
- 12) Steps 6 to 11 should be repeated until all the frequencies in the results sheet (see table 9) have been completed, changing the dipoles as appropriate.
- 13) Steps 6 to 12 should be repeated with the transmitting dipole at the nine other positions as shown in figures 26 and 31.

NOTE 5: In figures 26 and 31, for both 3 m and 10 m range length verifications, $d = 0,7$ m. The positioning accuracy of all positions relative to position 1 should be $\pm 0,01$ m.

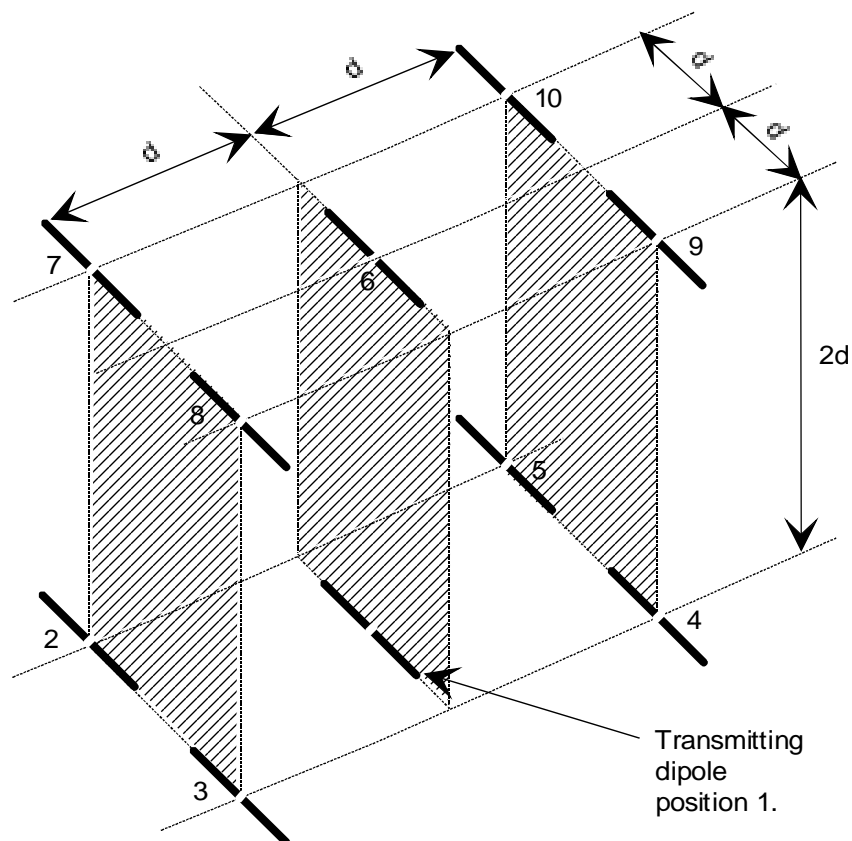

Figure 31: Expanded view of the 10 transmitting dipole positions

Radiated attenuation: Vertical polarization

- 14) The equipment should be connected as shown in figure 29 with the dipoles vertically polarized.
- 15) The signal generator, receiving device and dipoles should be tuned to the appropriate frequency (starting at the top of the results sheet shown in table 9).

NOTE 6: For all frequencies below 80 MHz, a shortened dipole (as defined in clause 6.3.3) should be used. The dipole arm length is defined as the measured distance from the centre of the balun used to the tip of the arm. From a fully extended state, each telescopic element, in turn, should be "pushed in" from the tip until the required length is obtained. The outermost section needs to fully compress before any of the others, and so on.

- 16) The antenna mast should allow the height of the dipole above the ground plane to be varied between 1 m and 4 m. The whole of the dipole should lie in the plane of symmetry of the chamber as shown in figure 30.

NOTE 7: No part of the receiving dipole should come within 1 m of the tips of the absorbing material. For those chambers whose maximum height scans are reduced below 4 m by this restriction, the verification procedure should not be carried out (the correction factors and NSA figures given in the text will not be valid). Additionally, no part of the receiving dipole should come within 0,25 m of the ground plane. This latter condition will limit the height scanning range in vertically polarized verification procedures in all chambers for frequencies from 30 MHz up to 90 MHz inclusive.

17) The range length (3 m or 10 m) is defined as the horizontal distance between the receiving dipole and the axis of rotation of the turntable. This should be set to an accuracy of $\pm 0,01$ m.

18) The transmitting dipole should be mounted in position 1 as shown in figures 27 and 31 and oriented for vertical polarization. It should be positioned with its phase centre 1,5 m above the ground plane. The whole of the dipole should lie in the plane of symmetry of the chamber and the axis of the dipole should lie on the axis of rotation of the turntable.

19) The receiving dipole should be raised and lowered through the specified range of heights (with the strict limitations that its lowest point should never be less than 0,25 m above the ground plane and its highest point never less than 1 m from the ceiling absorbers), whilst monitoring the level of the received signal. The receiving dipole should then be positioned at the height of maximum received signal and the height recorded under "Dipole height" in the results sheet (see table 9).

NOTE 8: The true maximum may lie beyond the top of the mast, in which case the maximum receivable level may be at the top of the height range. Alternatively, due to the 0,25 m limitation on the spacing away from the ground plane, the true maximum may be below the lowest possible height, in which case the maximum received level will be at the lowest point in the available height range.

20) The output level of the signal generator should be checked (to ensure that an inadvertent change to the original set level has not occurred) and the received level on the receiving device should be noted. This value should be entered in the results sheet (see table 9) under the column headed "Site".

21) Steps 15 to 20 should be repeated until all the frequencies in the results sheet (see table 9) have been completed, changing the dipoles as appropriate.

22) Steps 15 to 21 should be repeated with the transmitting dipole at the nine other positions as shown in figures 27 and 31.

NOTE 9: In figures 27 and 31, for both 3 m and 10 m range length verifications, $d = 0,7$ m. The positioning accuracy of all positions relative to position 1 should be $\pm 0,01$ m.

Table 9: Anechoic Chamber with a Ground Plane verification results sheet (30 MHz to 1 000 MHz)

Anechoic Chamber with a Ground Plane verification procedure results sheet 30 MHz to 1 000 MHz									
Range length:.....m			Polarization:			Date:.....			
Ambient temperature:.....°C			Position Number:.....			Relative humidity:.....%			
Freq. (MHz)	Direct V _{direct} (dBμV)	Dipole height (m)	Site V _{site} (dBμV)	Transmit Antenna factor AF _T (dB)	Receive Antenna factor AF _R (dB)	Mutual coupling correction AFTOT (dB)	Overall value (dB)	Ideal value (dB)	Difference (dB)
30									
35									
40									
45									
50									
60									
70									
80									
90									
100									
120									
140									
160									
180									
200									
250									
300									
400									
500									
600									
700									
800									
900									
1 000									
Transmit antenna: Dipole S/No. D 001 Transmit antenna cable: Ref. No. C 128 Attenuator: Ref. No. AT 01 Signal generator: Ref. No. SG 001 Ferrite type: Worry beads				Receive antenna: Dipole S/No. D 002 Receive antenna cable: Ref. No. C 129 Attenuator: Ref. No. AT 02 Receiving device: Ref. No. SA 001 Ferrite manufacturer: Rusty co. Ltd.					

6.4.2 Alternative procedure: 30 MHz to 1 000 MHz

The procedure contained in clause 6.4.1 is the most accurate procedure considered for verification in the 30 MHz to 1 000 MHz band - the use of ANSI C63.5 [1] dipoles enabling precise correction figures for mutual coupling to be incorporated into the results. The procedure can be very time consuming however and, as a quicker, alternative scheme, the following less accurate procedure could be adopted.

- 1) The procedure, as detailed in clause 6.4.1 should be completed for the transmitting dipole in position 1 for both horizontal and vertical polarization.
- 2) Both transmitting and receiving dipoles should be replaced with bicones for the full 30 MHz to 1 000 MHz band.

NOTE 1: As a further alternative, bicones 30 MHz - 200 MHz (possibly 300 MHz) can be used with LPDAs for the rest of the band. Note, however, that the range length uncertainty associated with the moving phase centre of the latter can significantly increase measurement uncertainty (e.g. a typical design of LPDA with length approximately 1 m, could contribute a range length uncertainty of $u_j = 1,73$ dB over a 3 m range length. This would reduce to $u_j = 0,5$ dB for a 10 m range length but would remain a significant contribution to the uncertainty).

CAUTION: For reduced uncertainty in the verification procedure, measurements using alternative antennas should be carried out in their far-fields (TR 102 273-1-1 [8]). For a typical bicone of length 1,315 m, far-field conditions over a 3 m range length only exist from 30 MHz to 60 MHz and not at 70 MHz or above. For a 10 m range length, the corresponding usable frequency range is 30 MHz to 270 MHz.

- 3) The entire verification procedure as described in steps 1 to 22 should be repeated, including position 1 for the transmitting antenna.

NOTE 2: This alternative procedure does not include any correction factors to account for mutual coupling effects. Whilst these effects are smaller for broadband antennas than for dipoles, there will be increased uncertainty in this alternative verification process because the effects cannot be calculated out of the measurements.

6.4.3 Procedure 2: 1 GHz to 12,75 GHz

Direct attenuation

- 1) The two antenna cables should be connected together, via attenuator pads and an "in-line" adapter as shown in figure 32. Alternatively, if this is not practical, a calibrated cable may be used instead of the adapter.

NOTE 1: The use of a cable will increase the expanded measurement uncertainty.

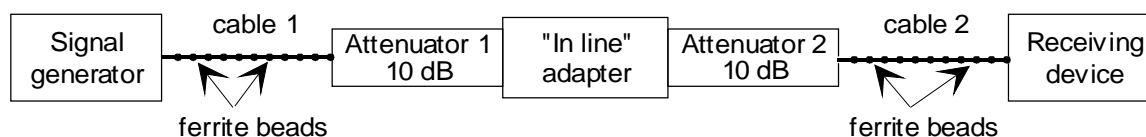

Figure 32: Initial equipment arrangement for the verification tests

- 2) The output of the signal generator should be adjusted to an appropriate level. The minimum acceptable level for any frequency in the band of interest may be calculated from:

- 20 dB above the maximum expected radiated path loss ($20 \log ((4\pi \text{ range length})/\lambda)$), plus the ambient noise floor, the value of the attenuator pads and the cable losses, minus the antenna gains.

NOTE 2: For practical purposes it is advisable to set a single output level for all frequencies in the band, since this avoids level changes during the verification.

EXAMPLE: $20 \text{ dB} + 75 \text{ dB (maximum expected path loss)} - 110 \text{ dB (ambient noise floor)} + 20 \text{ dB (attenuator pads)} + 15 \text{ dB (cable losses)} - 10 \text{ dB (antenna gains)} = + 10 \text{ dBm (117 dB}\mu\text{V)}$.

If the calculated level is not available then the verification should not proceed.

Once set, this signal generator output level should not be adjusted again for the entire duration of the verification procedure.

- 3) The receiving device and signal generator should be tuned to the appropriate frequency (starting at the first frequency given in the result sheet shown in table 9). The output level of the signal generator should be checked (to be certain that the original set level has been maintained) and the received level on the receiving device should be noted. For each frequency, the value to be entered in the column headed "Direct" on the results sheet is the sum of this received level plus the loss of the "in-line" adapter or cable at this frequency i.e.:

"Direct" value = received level + loss of "in-line" adapter or cable.

- 4) Step 3 should be repeated for all frequencies in the results sheet shown in table 10.

Radiated attenuation: Horizontal polarization

- 5) The adapter used to make the direct connection between the attenuator pads should be removed and the transmit and receive antennas should be connected as shown in figure 33 with the LPDAs horizontally polarized.

NOTE 3: In order to minimize the uncertainty in range length which results from using LPDAs (the radiating phase centre moves with frequency), the radiating phase centre is defined, for the purposes of this procedure, as the point on the LPDAs central axis where its thickness is 0,08 m. This is shown in figure 34.

- 6) The receiving antenna should be mounted on the antenna mast and oriented for horizontal polarization. The mast should allow the height of the antenna above the ground plane to be varied between 1 m and 4 m, subject to the restrictions that no part of the antenna should be less than 1 m away from the absorbers and 0,25 m away from the ground plane. The procedure should not be carried out in facilities that cannot provide the full 1 m to 4 m height scan. The phase centre of the antenna should lie in the plane of symmetry of the chamber (see figure 30) and the axis of the antenna should be parallel to the floor.
 - 7) The horizontal spacing between the phase centre of the receiving LPDA and the axis of rotation of the turntable is the range length. This should be set to an accuracy of $\pm 0,01$ m.
 - 8) The transmitting antenna should be mounted in position 1 as shown in figures 26 and 31, with its central axis 1,5 m above the floor, in the plane of symmetry of the chamber and parallel to the floor. The phase centre of the transmitting antenna should lie on the axis of rotation of the turntable. The transmitting antenna should be oriented for horizontal polarization.
 - 9) The signal generator and receiving device should be tuned to the appropriate frequency (starting at the top of the results sheet shown in table 10).
 - 10) The position of the receiving antenna should be varied over the 1 m to 4 m height range, whilst monitoring the level of received signal. The receiving antenna should then be positioned at the height of maximum received signal and the height recorded under "LPDA height" in the results sheet (see table 10).
- NOTE 4: The true maximum may lie beyond the top of the mast, in which case the maximum receivable level will be at the top of the height range.
- 11) The output level of the signal generator should be checked (to ensure that an inadvertent change to the original set level has not occurred) and the received level on the receiving device should be noted. This value should be entered in the results sheet (see table 10) under the column headed "Site".
 - 12) Steps 9, 10 and 11 should be repeated until all the frequencies in the results sheet (see table 10) have been completed.

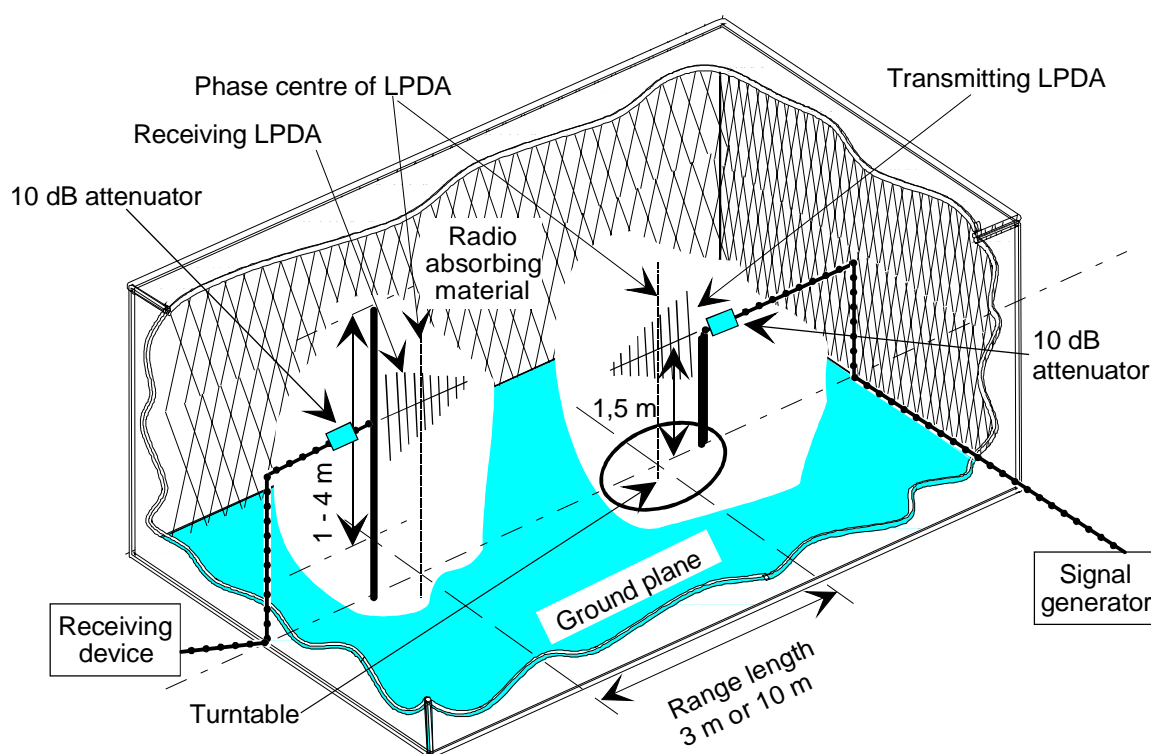

Figure 33: Anechoic Chamber with a Ground Plane layout for verification with LPDAs

- 13) Steps 9, 10, 11 and 12 should be repeated with the transmitting antenna at the nine other positions as shown in figures 26 and 31.

NOTE 5: In figures 26 and 31, for both 3 and 10 m range length verifications, $d = 0,7$ m. The positioning accuracy of the phase centres for all positions relative to position 1 should be $\pm 0,01$ m.

NOTE 6: For all positions, both antennas needs to point directly towards each other, consistent with keeping their central axes parallel to the floor. For all transmitting positions other than 1 and 6 in figures 26 and 31, this will involve small angle rotation of both receiving and transmitting antennas. For both antennas, this rotation should be about the phase centre.

Radiated attenuation: Vertical polarization

14) The equipment should be connected as shown in figure 33.

NOTE 7: In order to minimize the uncertainty in range length which results from using LPDAs (the radiating phase centre moves with frequency), the radiating phase centre is defined, for the purposes of these measurements, as the point on the LPDAs central axis where its thickness is 0,08 m. This is shown in figure 34.

15) The receiving antenna should be oriented for vertical polarization. The mast should allow the height of the antenna above the ground plane to be varied between 1 m and 4 m subject to the restrictions that no part of the antenna should be less than 1 m away from the absorbers and 0,25 m away from the ground plane. The procedure should not be carried out in facilities that cannot provide the full 1 m to 4 m height scan range. The central axis of the antenna should lie in the plane of symmetry of the chamber (see figure 30) and parallel to the floor.

Table 10: Anechoic Chamber with a Ground Plane verification results sheet (1 GHz to 12,75 GHz)

Anechoic Chamber with a Ground Plane verification procedure results sheet 1 GHz to 12,75 GHz								
Range length:.....m			Polarization:			Date:.....		
Ambient temperature:.....°C			Position Number:.....			Relative humidity:.....%		
Freq. (GHz)	LPDA height (m)	Direct Vdirect (dBμV)	Site Vsite (dBμV)	Transmit Antenna factor AF _T (dB)	Receive Antenna factor AF _R (dB)	Overall value (dB)	Ideal value (dB)	Difference (dB)
1,0								
1,25								
1,5								
1,75								
2,0								
2,25								
2,5								
2,75								
3,0								
3,25								
3,5								
3,75								
4,0								
4,5								
5,0								
5,5								
6,0								
6,5								
7,0								
7,5								
8,0								
8,5								
9,0								
9,5								
10,0								
10,5								
11,0								
11,5								
12,0								
12,75								
Transmit antenna Transmit antenna cable: Signal generator: Attenuator: Ferrite type:			Receive antenna: Receive antenna cable: Receiving device: Attenuator: Ferrite manufacturer:					

- 16) The horizontal spacing between the phase centre of the LPDA and the centre of the turntable is the range length. This should be set to an accuracy of $\pm 0,01$ m.
- 17) The transmitting antenna should be mounted in position 1 as shown in figures 27 and 31, with its central axis 1,5 m above the floor, in the plane of symmetry of the chamber and parallel to the floor. The phase centre of the transmitting antenna should lie on the axis of rotation of the turntable. The transmitting antenna should be oriented for vertical polarization.
- 18) The signal generator and receiving device should be tuned to the appropriate frequency (starting at the top of the results sheet shown in table 10).
- 19) The position of the receiving antenna should be varied over the 1 m to 4 m height range, whilst monitoring the level of received signal. The receiving antenna should then be positioned at the height of maximum received signal and the height recorded under "LPDA height" in the results sheet (see table 10).

NOTE 8: The true maximum may lie beyond the top of the mast, in which case the maximum receivable level may be at the top of the height range.

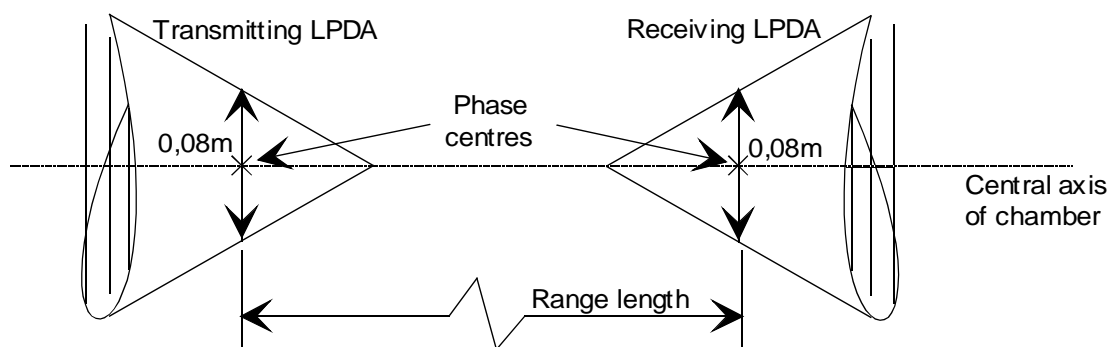

Figure 34: Definition of the phase centre of the LPDA

20) The output level of the signal generator should be checked (to ensure that an inadvertent change to the original set level has not occurred) and the received level on the receiving device should be noted. This value should be entered in the results sheet (see table 10) under the column headed "Site".

21) Steps 18, 19 and 20 should be repeated until all the frequencies in the results sheet (see table 10) have been completed.

22) Steps 18, 19, 20 and 21 should be repeated with the transmitting antenna at the 9 other positions as shown in figures 27 and 31.

NOTE 9: In figures 27 and 31, for both 3 and 10 m range length verifications, $d = 0,7$ m. The positioning accuracy of the phase centres of all positions relative to position 1 should be $\pm 0,01$ m.

NOTE 10: For all positions, both antennas need to point directly towards each other, consistent with keeping their central axes parallel to the floor. For all transmitting positions other than 1 and 6 in figures 27 and 31, this will involve small angle rotation of both receiving and transmitting antennas. For both antennas, this rotation should be about the phase centre.

6.5 Processing the results of the verification procedure

6.5.1 Introduction

Having carried out the verification procedures as detailed in clause 6.4 the results sheets should have values filling the first four columns, namely those headed "Freq", "Dipole height" or "LPDA height", "Direct" and "Site". This clause details the values to be incorporated in all the remaining columns.

The processing of the results finally reveals how well the measured performance of the Anechoic Chamber with a Ground Plane compares to the ideal case.

Firstly, the figures for entering under the column headings of "Transmit Antenna factor AF_T " and "Receive Antenna factor AF_R " are discussed and values are provided. Secondly, for the 30 MHz to 1 000 MHz verification procedure only, correction factors are provided for the recommended antenna scheme (ANSI C63.5 [1] dipoles) to allow for the effects of mutual coupling and mismatch loss. These effects are regarded as not significant at frequencies above 180 MHz and enable the column headed "Mutual coupling correction AF_{TOT} " to be completed. The "Overall value" column can then be calculated. This column reveals the measured NSA for the Anechoic Chamber with a Ground Plane.

Finally, having extracted the relevant values (from tables provided) to complete the "Ideal value" column, the difference between the measured performance and the ideal can be calculated by simple subtraction of the values in the columns "Overall value" and "Ideal value".

6.5.2 Procedure 1: 30 MHz to 1 000 MHz

Antenna factors

For dipoles, the antenna factor of each dipole is given by:

$$\text{Antenna factor} = 20 \log f - 31,4 \text{ dB}$$

where f is the frequency in MHz.

NOTE 1: A resistive loss of 0,5 dB is incorporated into this formula.

Whilst the above formula for antenna factor applies only to a tuned half wavelength dipole, it should still be used in this verification procedure, even where shortened dipoles have been used (the 30 MHz to 70 MHz band). Table 11 gives the values at the test frequencies. The relevant values should be entered in the verification results sheet (see table 9) in the columns headed "Transmit Antenna factor AF_T " and "Receive Antenna factor AF_R ".

NOTE 2: Table 11 applies for both horizontal and vertical polarization.

When antennas other than dipoles are used, antenna factors are usually provided by the manufacturers. Where gain figures, rather than antenna factors, have been given, these can be converted into antenna factor by the following equation:

$$\text{Antenna factor} = 20 \log \left(\frac{9,734}{\lambda \sqrt{G}} \right) \text{ dB} \quad (6.21)$$

where:

λ is the wavelength (m);

G is the numeric gain.

NOTE 3: The gain figure to be used should be relative to an isotropic radiator - not relative to a dipole.

Table 11: Antenna factor for a dipole used in the verification procedure

Frequency (MHz)	Antenna factor (dB)	Frequency (MHz)	Antenna factor (dB)
30	-1,9	160	12,7
35	-0,5	180	13,7
40	0,6	200	14,6
45	1,7	250	16,6
50	2,6	300	18,1
60	4,2	400	20,6
70	5,5	500	22,6
80	6,7	600	24,2
90	7,7	700	25,5
100	8,6	800	26,7
120	10,2	900	27,7
140	11,5	1 000	28,6

Mutual coupling mismatch loss correction factors

Tables 12 and 13 give the factors necessary to correct the measured figures not only for mutual coupling, but also for mismatch transmission loss - this being the dominant term for frequencies up to 70 MHz. Table 12 applies for horizontal polarization, table 13 for vertical polarization.

NOTE 4: Particularly at low frequencies (i.e. up to 180 MHz) the performance of each antenna used in the verification procedure is affected by the presence of the other antenna and the ground plane. These interactions are termed mutual coupling and have been modelled by computer simulation for the recommended antenna scheme (ANSI dipoles) only.

For the recommended dipole antenna scheme only, the relevant figures should be taken from tables 12 or 13 and entered in the results sheet (see table 9) in the column headed "Mutual coupling correction AF_{TOT} ". For all frequencies above 180 MHz, the correction factor should be taken as 0,0 dB.

For the alternative antenna schemes (bicones only or bicones and LPDAs) all entries in the "Mutual coupling correction factor AF_{TOT} " column should be 0,0 dB.

Table 12: Mutual coupling correction factors for horizontal polarization

Receiving height scan: 1 m to 4 m AF_{TOT} (dB)												
Freq. (MHz)	Range length: 3 m Various positions						Range length: 10 m Various positions					
	1	2 3	4 5	6	7 8	9 10	1	2 3	4 5	6	7 8	9 10
30	53,23	53,49	52,36	52,93	52,91	52,18	51,59	51,64	51,51	51,61	51,57	51,50
35	47,76	47,80	47,05	47,50	47,39	47,03	46,50	46,54	46,43	46,55	46,59	46,48
40	42,51	42,42	41,93	42,37	42,18	41,97	41,41	41,44	41,45	41,56	41,56	41,52
45	37,06	37,03	36,60	37,05	36,89	36,73	36,21	36,13	36,16	36,44	36,40	36,44
50	31,40	31,24	30,86	31,48	31,27	31,23	30,40	30,42	30,47	30,78	30,79	30,82
60	18,56	18,72	17,93	18,89	18,52	18,65	17,88	17,86	17,87	17,93	17,92	17,96
70	3,99	4,39	3,59	3,72	3,72	3,37	4,42	4,46	4,44	2,79	2,60	2,95
80	0,61	0,64	1,02	1,72	1,70	0,73	0,81	0,81	0,77	0,35	0,45	0,22
90	0,24	-0,38	-0,13	1,87	1,34	0,61	0,37	0,22	0,26	0,50	0,40	0,28
100	-0,29	-1,16	-1,15	1,23	0,00	0,50	-0,04	-0,14	0,01	0,14	0,04	-0,08
120	-2,27	-0,99	-1,60	-0,65	-0,38	-0,28	-1,31	-1,35	-1,34	-0,48	-0,68	-0,79
140	-0,89	-1,14	-1,30	0,61	0,03	0,91	-0,53	-0,50	-0,48	0,43	0,32	0,31
160	-0,17	-0,04	0,04	-0,52	-0,35	-0,03	0,44	0,37	0,50	-0,20	-0,30	-0,41
180	-0,18	-0,09	-0,23	-0,15	-0,13	0,51	0,40	0,43	0,45	0,10	-0,11	-0,22

Table 13: Mutual coupling correction factors for vertical polarization

Receiving height scan : limited (30 MHz to 90 MHz) : 1 m to 4 m (100 MHz to 180 MHz) AF_{TOT} dB												
Freq. (MHz)	Range length: 3 m Various positions						Range length: 10 m Various positions					
	1	2 3	4 5	6	7 8	9 10	1	2 3	4 5	6	7 8	9 10
30	50,79	50,72	50,83	50,78	51,40	50,24	51,04	51,00	51,04	50,90	50,87	50,94
35	45,54	45,45	45,70	46,08	46,89	45,16	46,03	46,04	46,03	45,90	45,86	45,93
40	40,44	40,35	40,74	41,64	42,42	40,24	41,07	41,07	41,08	40,94	40,90	40,97
45	35,26	35,06	35,49	37,12	37,83	35,39	35,96	35,95	35,97	35,78	35,74	35,82
50	29,78	29,56	30,04	32,11	32,61	30,13	30,50	30,49	30,50	30,25	30,21	30,29
60	17,50	17,36	17,73	19,50	19,68	19,06	18,26	18,24	18,28	17,79	17,74	17,82
70	3,20	3,35	3,71	4,35	4,65	4,55	4,09	4,12	4,11	3,75	3,70	3,80
80	0,00	-0,33	0,30	1,12	1,04	1,06	0,42	0,51	0,45	0,82	0,84	0,92
90	-0,19	-0,78	-0,25	0,53	0,19	1,30	0,09	0,10	0,02	0,59	0,61	0,58
100	-0,55	-0,43	-0,28	0,26	0,04	0,04	0,01	0,00	0,06	0,46	0,37	0,41
120	-0,53	1,44	-0,52	-0,22	0,80	0,18	0,03	-0,03	-0,02	0,06	0,27	0,11
140	1,18	1,10	0,84	0,82	0,71	-0,02	-0,01	0,04	0,04	0,24	0,28	0,29
160	0,78	0,74	0,69	0,55	0,31	0,35	0,07	0,07	0,06	0,22	0,27	0,19
180	0,41	0,55	0,31	0,29	0,26	0,23	0,09	0,06	0,10	0,23	0,23	0,21

Table 14: Ideal values for NSA for horizontal polarization

Freq: (MHz)	Ideal NSA (dB)											
	Range length: 3 m Various positions						Range length: 10 m Various positions					
	1	2 3	4 5	6	7 8	9 10	1	2 3	4 5	6	7 8	9 10
30	12,79	11,53	15,16	9,39	8,51	11,54	26,41	25,46	27,50	21,50	20,63	22,50
35	10,48	9,24	12,79	7,64	6,85	9,71	23,82	22,88	24,90	19,08	18,24	20,05
40	8,51	7,30	10,79	6,25	5,54	8,25	21,59	20,66	22,66	17,04	16,24	17,98
45	6,81	5,64	9,07	5,11	4,48	7,04	19,64	18,72	20,69	15,32	14,56	16,22
50	5,34	4,20	7,58	4,16	3,57	6,01	17,91	17,01	18,95	13,85	13,14	14,71
60	2,91	1,85	5,14	2,58	2,05	4,32	14,97	14,10	15,99	11,54	10,94	12,30
70	1,01	0,01	3,21	1,28	0,78	2,93	12,56	11,72	13,55	9,91	9,40	10,54
80	-0,53	-1,46	1,66	0,16	-0,33	1,75	10,56	9,76	11,50	8,63	8,13	9,25
90	-1,81	-2,69	0,36	-0,84	-1,31	0,72	8,86	8,11	9,77	7,53	7,03	8,15
100	-2,91	-3,74	-0,75	-1,73	-2,20	-0,20	7,44	6,74	8,29	6,56	6,06	7,18
120	-4,70	-5,49	-2,57	-3,22	-3,99	-1,79	5,24	4,68	5,97	4,91	4,41	5,52
140	-6,16	-6,91	-4,05	-4,76	-5,38	-2,96	3,68	3,15	4,33	3,52	3,03	4,14
160	-7,39	-8,02	-5,30	-5,95	-6,51	-4,13	2,40	1,87	3,04	2,34	1,84	2,95
180	-8,43	-8,62	-6,38	-6,96	-7,48	-5,22	1,29	0,76	1,93	1,29	0,80	1,91
200	-9,12	-8,67	-7,34	-7,85	-8,42	-6,17	0,31	-0,21	0,96	0,37	-0,13	0,98
250	-10,33	-11,33	-8,84	-9,82	-10,41	-8,15	-1,72	-2,24	-1,07	-1,59	-2,08	-0,98
300	-12,38	-13,25	-10,21	-11,40	-11,99	-9,74	-3,35	-3,88	-2,71	-3,05	-3,48	-2,55
400	-15,24	-16,00	-13,12	-13,90	-14,50	-12,23	-5,90	-6,42	-5,25	-5,58	-6,08	-4,96
500	-17,30	-17,68	-15,21	-15,84	-16,44	-14,18	-7,86	-8,35	-7,21	-7,57	-8,06	-6,95
600	-18,66	-19,45	-16,88	-17,43	-18,02	-15,77	-9,22	-9,75	-8,69	-9,18	-9,67	-8,56
700	-20,13	-20,88	-18,02	-18,77	-19,36	-17,10	-10,63	-11,16	-9,99	-10,53	-11,02	-9,92
800	-21,37	-21,91	-19,27	-19,93	-20,52	-18,26	-11,84	-12,36	-11,19	-11,70	-12,14	-11,09
900	-22,24	-23,02	-20,36	-20,95	-21,54	-19,29	-12,89	-13,42	-12,25	-12,68	-13,18	-12,07
1 000	-23,24	-23,99	-21,31	-21,87	-22,46	-20,20	-13,83	-14,35	-13,18	-13,61	-14,11	-13,00

Completion of the results sheet

The next stage is to enter values in the column headed "Overall value". This is achieved by performing the following calculation:

$$\text{"Overall value"} = \text{"V}_{\text{direct}} - \text{"V}_{\text{site}} - \text{"AF}_{\text{T}} - \text{"AF}_{\text{R}} - \text{"AF}_{\text{TOT}} \quad (6.22)$$

The resulting value is the measured NSA for the Anechoic Chamber with a Ground Plane.

The final stages in determining the quality of the site are to complete the column headed "Ideal value" in the results sheet by taking the relevant values from tables 14 or 15 (for horizontal and vertical polarization respectively) and to calculate the entries for the "Difference" column from:

$$\text{"Difference"} = \text{"Overall value"} - \text{"Ideal value"} \quad (6.23)$$

The values in the "Difference" column represent the variation between the theoretical and the measured NSA of the Anechoic Chamber with a Ground Plane.

Table 15: Ideal values for NSA for vertical polarization

Freq: (MHz)	Ideal NSA (dB)											
	Range length: 3 m Various positions						Range length: 10 m Various positions					
	1	2 3	4 5	6	7 8	9 10	1	2 3	4 5	6	7 8	9 10
30	9,84	8,90	10,85	12,34	10,32	14,28	17,00	16,47	17,53	18,02	17,62	18,43
35	8,60	7,69	9,58	11,16	9,05	13,28	15,67	15,15	16,21	16,73	16,34	17,14
40	7,55	6,67	8,51	10,08	7,90	12,38	14,53	14,00	15,06	15,62	15,24	16,03
45	6,65	5,79	7,58	9,05	6,84	11,48	13,52	13,00	14,05	14,66	14,29	15,06
50	5,88	5,04	6,78	8,03	5,83	10,50	12,63	12,11	13,16	13,82	13,45	14,21
60	4,62	3,82	5,45	6,07	3,99	8,41	11,09	10,58	11,61	12,40	12,06	12,77
70	3,67	2,91	4,42	4,35	2,45	6,45	9,80	9,30	10,32	11,26	10,94	11,60
80	2,97	2,24	3,62	2,96	1,24	4,82	8,71	8,21	9,22	10,33	10,05	10,64
90	2,47	1,75	3,01	1,90	0,34	3,53	7,76	7,27	8,26	9,57	9,33	9,86
100	2,15	1,23	2,58	1,14	-0,34	2,54	6,92	6,45	7,41	8,96	8,77	9,21
120	1,56	-1,11	2,15	0,25	-1,67	1,15	5,53	5,09	5,99	8,12	7,31	8,26
140	-1,03	-3,35	1,41	-1,27	-3,46	0,17	4,42	4,01	4,85	5,83	5,29	6,43
160	-3,14	-5,20	-0,95	-3,01	-4,77	-0,91	3,53	3,16	3,92	4,30	3,79	4,83
180	-4,82	-6,66	-2,82	-4,11	-5,47	-2,44	2,81	2,50	3,17	3,04	2,55	3,55
200	-6,17	-7,82	-4,32	-4,75	-6,20	-3,48	2,25	2,00	2,56	1,96	1,48	2,46
250	-8,63	-9,89	-7,08	-6,95	-8,55	-5,10	0,83	0,23	1,57	-0,22	-0,67	0,26
300	-10,38	-11,36	-9,04	-8,23	-10,19	-7,01	-1,51	-2,10	-0,93	-1,93	-2,37	-1,46
400	-12,10	-13,81	-11,83	-10,90	-12,72	-9,50	-4,75	-5,32	-4,18	-4,55	-4,98	-4,09
500	-14,64	-15,91	-13,06	-12,97	-14,52	-11,44	-7,03	-7,59	-6,46	-6,54	-6,96	-6,09
600	-16,40	-17,37	-15,05	-14,58	-16,20	-13,03	-8,79	-9,35	-8,23	-7,95	-8,39	-7,63
700	-17,77	-18,84	-16,58	-15,92	-17,60	-14,37	-10,24	-10,80	-9,68	-9,36	-9,79	-8,90
800	-18,80	-19,97	-17,85	-17,07	-18,73	-15,52	-11,47	-12,03	-10,91	-10,57	-11,00	-10,11
900	-19,92	-21,01	-18,57	-18,07	-19,71	-16,55	-12,54	-13,10	-11,98	-11,62	-12,05	-11,17
1 000	-20,87	-21,93	-19,63	-18,99	-20,69	-17,46	-13,49	-13,91	-12,93	-12,56	-12,98	-12,11

6.5.3 Procedure 2: 1 GHz to 12,75 GHz

Antenna factors

Generally, the manufacturer of the LPDAs will supply figures for either the gain or antenna factor variation with frequency. Where the gain variation is given, this should be converted to antenna factor by the following formula:

$$\text{Antenna factor} = 20 \log \left(\frac{9,734}{\lambda \sqrt{G}} \right) \text{dB} \quad (6.24)$$

where:

λ is the wavelength (m);

G is the numeric gain.

NOTE: The gain figure to be used should be relative to an isotropic radiator - not relative to a dipole.

Whether directly or indirectly (by using the formula), the antenna factor columns in the results sheet headed "Transmit Antenna factor AF_T " and "Receive Antenna factor AF_R " should now be filled in with the relevant values.

Table 16: Ideal values of NSA for horizontal polarization (1 GHz to 12,75 GHz)

Freq: (GHz)	Ideal NSA (dB)											
	Range length: 3 m Various positions						Range length: 10 m Various positions					
	1	2 3	4 5	6	7 8	9 10	1	2 3	4 5	6	7 8	9 10
1,0	-21,33	-22,47	-20,28	-19,28	-20,85	-17,85	-13,47	-14,03	-12,89	-12,83	-13,30	-12,35
1,25	-23,24	-24,41	-22,12	-21,21	-22,77	-19,78	-15,50	-16,07	-14,93	-14,82	-15,28	-14,34
1,5	-24,96	-26,00	-23,63	-22,79	-24,37	-21,37	-17,14	-17,49	-16,56	-16,37	-16,84	-15,89
1,75	-26,27	-27,34	-25,12	-24,13	-25,72	-22,71	-18,35	-18,92	-17,78	-17,74	-18,20	-17,26
2,0	-27,41	-28,49	-26,22	-25,30	-26,88	-23,87	-19,57	-20,13	-19,00	-18,88	-19,34	-18,44
2,25	-28,50	-29,52	-27,33	-26,32	-27,90	-24,90	-20,63	-21,19	-20,06	-19,92	-20,39	-19,44
2,5	-29,40	-30,43	-28,20	-27,24	-28,81	-25,81	-21,57	-22,03	-21,00	-20,82	-21,29	-20,38
2,75	-30,21	-31,26	-28,99	-28,07	-29,64	-26,64	-22,33	-22,89	-21,81	-21,67	-22,13	-21,19
3,0	-30,95	-32,01	-29,82	-28,82	-30,40	-27,40	-23,11	-23,68	-22,54	-22,41	-22,87	-21,96
3,25	-31,69	-32,71	-30,48	-29,52	-31,10	-28,09	-23,83	-24,40	-23,26	-23,12	-23,58	-22,64
3,5	-32,32	-33,36	-31,18	-30,16	-31,74	-28,73	-24,49	-24,98	-23,92	-23,77	-24,21	-23,29
3,75	-32,91	-33,95	-31,75	-30,76	-32,34	-29,33	-25,04	-25,61	-24,54	-24,36	-24,82	-23,90
4,0	-33,49	-34,52	-32,28	-31,32	-32,90	-29,89	-25,62	-26,19	-25,05	-24,93	-25,37	-24,45
4,5	-34,50	-35,54	-33,32	-32,34	-33,92	-30,92	-26,68	-27,19	-26,11	-25,95	-26,40	-25,48
5,0	-35,44	-36,45	-34,25	-33,26	-34,84	-31,83	-27,57	-28,13	-27,00	-26,87	-27,31	-26,39
5,5	-36,25	-37,28	-35,10	-34,09	-35,67	-32,66	-28,42	-28,94	-27,85	-27,70	-28,14	-27,22
6,0	-37,02	-38,04	-35,86	-34,84	-36,42	-33,41	-29,16	-29,72	-28,61	-28,45	-28,90	-27,99
6,5	-37,70	-38,73	-36,52	-35,54	-37,12	-34,11	-29,87	-30,40	-29,30	-29,14	-29,60	-28,68
7,0	-38,35	-39,38	-37,18	-36,18	-37,76	-34,75	-30,50	-31,06	-29,96	-29,79	-30,24	-29,32
7,5	-38,94	-39,97	-37,78	-36,78	-38,36	-35,35	-31,11	-31,65	-30,54	-30,39	-30,84	-29,92
8,0	-39,51	-40,54	-38,35	-37,34	-38,92	-35,91	-31,66	-32,23	-31,12	-30,95	-31,40	-30,48
8,5	-40,05	-41,06	-38,89	-37,87	-39,45	-36,44	-32,20	-32,74	-31,63	-31,47	-31,92	-31,00
9,0	-40,53	-41,56	-39,36	-38,37	-39,94	-36,94	-32,68	-33,25	-32,14	-31,97	-32,42	-31,50
9,5	-41,01	-42,03	-39,83	-38,83	-40,41	-37,41	-33,17	-33,71	-32,60	-32,44	-32,89	-31,98
10,0	-41,44	-42,48	-40,29	-39,28	-40,86	-37,85	-33,60	-34,14	-33,05	-32,89	-33,34	-32,42
10,5	-41,87	-42,90	-40,72	-39,70	-41,28	-38,27	-34,04	-34,58	-33,47	-33,31	-33,76	-32,84
11,0	-42,27	-43,30	-41,13	-40,11	-41,69	-38,68	-34,43	-34,97	-33,88	-33,72	-34,17	-33,25
11,5	-42,66	-43,69	-41,49	-40,49	-42,07	-39,07	-34,83	-35,37	-34,26	-34,11	-34,55	-33,63
12,0	-43,03	-44,06	-41,87	-40,86	-42,44	-39,44	-35,19	-35,73	-34,64	-34,47	-34,92	-34,00
12,75	-43,56	-44,59	-42,39	-41,39	-42,97	-39,96	-35,71	-36,27	-35,16	-34,99	-35,45	-34,53

Table 17: Ideal values of NSA for vertical polarization (1 GHz to 12,75 GHz)

Freq: (GHz)	Ideal NSA (dB)											
	Range length: 3 m Various positions						Range length: 10 m Various positions					
	1	2	4	6	7	9	1	2	4	6	7	9
	1	3	5	6	8	10	1	3	5	6	8	10
1,0	-21,44	-22,46	-20,11	-19,26	-20,85	-17,84	-13,41	-14,05	-13,04	-12,88	-13,34	-12,40
1,25	-23,34	-24,40	-22,24	-21,21	-22,80	-19,79	-15,37	-15,93	-14,79	-14,78	-15,25	-14,30
1,5	-24,89	-25,98	-23,75	-22,80	-24,38	-21,37	-17,04	-17,61	-16,47	-16,40	-16,87	-15,92
1,75	-26,27	-27,33	-25,02	-24,14	-25,71	-22,71	-18,44	-19,00	-17,87	-17,71	-18,18	-17,23
2,0	-27,46	-28,49	-26,30	-25,30	-26,87	-23,87	-19,63	-20,05	-19,06	-18,90	-19,36	-18,42
2,25	-28,46	-29,52	-27,27	-26,32	-27,90	-24,89	-20,57	-21,13	-19,99	-19,90	-20,37	-19,46
2,5	-29,36	-30,43	-28,26	-27,24	-28,82	-25,81	-21,52	-22,09	-20,95	-20,84	-21,30	-20,36
2,75	-30,24	-31,26	-29,05	-28,07	-29,65	-26,64	-22,38	-22,94	-21,81	-21,65	-22,11	-21,20
3,0	-30,98	-32,02	-29,77	-28,82	-30,40	-27,39	-23,16	-23,63	-22,58	-22,42	-22,89	-21,94
3,25	-31,66	-32,71	-30,52	-29,52	-31,09	-28,09	-23,79	-24,36	-23,30	-23,13	-23,57	-22,65
3,5	-32,29	-33,36	-31,14	-30,16	-31,74	-28,73	-24,46	-25,02	-23,89	-23,76	-24,23	-23,28
3,75	-32,93	-33,96	-31,77	-30,76	-32,34	-29,33	-25,08	-25,64	-24,51	-24,37	-24,81	-23,89
4,0	-33,48	-34,51	-32,32	-31,32	-32,90	-29,89	-25,65	-26,15	-25,08	-24,92	-25,38	-24,46
4,5	-34,52	-35,54	-33,35	-32,34	-33,92	-30,92	-26,65	-27,22	-26,08	-25,94	-26,41	-25,48
5,0	-35,42	-36,45	-34,26	-33,26	-34,84	-31,83	-27,59	-28,11	-27,02	-26,86	-27,32	-26,40
5,5	-36,26	-37,28	-35,07	-34,09	-35,67	-32,66	-28,40	-28,96	-27,83	-27,69	-28,15	-27,22
6,0	-37,00	-38,04	-35,84	-34,84	-36,42	-33,42	-29,18	-29,70	-28,61	-28,44	-28,91	-27,98
6,5	-37,71	-38,73	-36,54	-35,54	-37,12	-34,11	-29,85	-30,42	-29,32	-29,14	-29,60	-28,67
7,0	-38,34	-39,38	-37,20	-36,18	-37,76	-34,75	-30,52	-31,04	-29,94	-29,79	-30,25	-29,31
7,5	-38,95	-39,98	-37,77	-36,78	-38,36	-35,35	-31,10	-31,66	-30,56	-30,39	-30,84	-29,92
8,0	-39,50	-40,54	-38,34	-37,34	-38,92	-35,91	-31,67	-32,21	-31,10	-30,95	-31,40	-30,48
8,5	-40,04	-41,06	-38,87	-37,87	-39,45	-36,44	-32,19	-32,75	-31,64	-31,48	-31,93	-31,01
9,0	-40,54	-41,56	-39,37	-38,36	-39,94	-36,94	-32,70	-33,24	-32,13	-31,97	-32,43	-31,50
9,5	-41,00	-42,03	-39,85	-38,83	-40,41	-37,41	-33,15	-33,72	-32,61	-32,44	-32,90	-31,97
10,0	-41,46	-42,47	-40,28	-39,28	-40,86	-37,85	-33,61	-34,15	-33,04	-32,89	-33,34	-32,42
10,5	-41,87	-42,90	-40,70	-39,70	-41,28	-38,28	-34,03	-34,57	-33,48	33,31	-33,77	-32,84
11,0	-42,28	-43,30	-41,12	-40,11	-41,69	-38,68	-34,44	-34,98	-33,87	-33,72	-34,17	-33,24
11,5	-42,66	-43,69	-41,50	-40,49	-42,07	-39,07	-34,82	-35,36	-34,27	-34,10	-34,56	-33,64
12,0	-43,04	-44,06	-41,88	-40,86	-42,44	-39,44	-35,20	-35,74	-34,63	-34,47	-34,93	-34,00
12,75	-43,56	-44,58	-42,40	-41,39	-42,97	-39,96	-35,72	-36,26	-35,17	-35,00	-35,45	-34,53

Completion of the results sheet

The next stage is to fill in the column headed "Overall value". The relevant values are determined by subtracting the combined values in the columns " V_{site} ", " AF_T " and " AF_R " from the value in the " V_{direct} " column i.e.:

$$\text{"Overall value"} = \text{"V}_{direct} - \text{V}_{site} - \text{"AF}_T - \text{"AF}_R \quad (6.25)$$

The resulting value is the measured NSA for the Anechoic Chamber with a Ground Plane.

The final stages in determining the quality of the chamber are to complete the column headed "Ideal Value" in the results sheet by taking the relevant values from tables 16 or 17 (for horizontal and vertical polarization respectively) and to calculate the entries for the "Difference" column from:

$$\text{"Difference"} = \text{"Overall value"} - \text{"Ideal value"} \quad (6.26)$$

The resulting values in the "Difference" column represent the variation between the ideal and the measured performance of the Anechoic Chamber with a Ground Plane.

6.5.4 Report format

It is suggested that the results of the verification are presented in two ways, firstly as indicated in the completed results sheets and secondly in the form of a plot of the "Difference" column against frequency for each polarization as shown in figure 35.

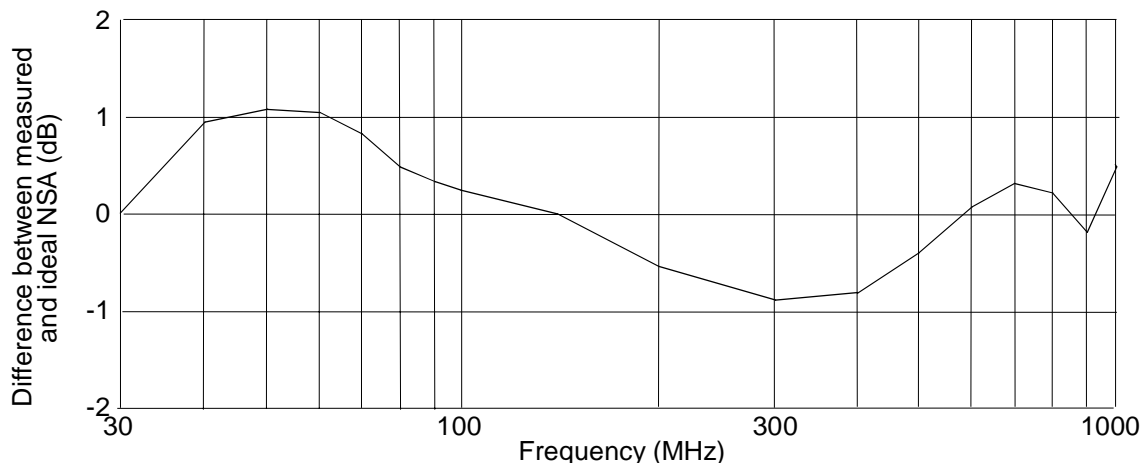

Figure 35: Plot of the difference between the measured and the ideal NSA against frequency

6.6 Calculation of measurement uncertainty (Procedure 1)

The column headed "Overall" in the results sheet is completed during the processing of the results for the verification procedure. The values entered in this column are the measured NSA figures for the Anechoic Chamber with a Ground Plane.

The value, at any particular frequency, for the measured NSA is "Direct" (reference value) less "Site" (the value appearing on the receiver during the NSA measurement) less the sum of "Transmit Antenna factor AF_T ", "Receive Antenna factor AF_R " and "Mutual coupling correction AF_{TOT} " i.e.:

$$\text{NSA} = \text{"Direct"} - \text{"Site"} - \text{"Transmit Antenna factor"} - \text{"Receive Antenna factor"} - \text{"Mutual coupling correction"} \quad (6.27)$$

As an example, let the direct attenuation be +10 dBm and the received level during the site measurement be -33 dBm. Putting both the antenna factors at 3,9 dB and the mutual coupling correction at 2,1 dB gives a measured NSA value of:

$$\text{NSA} = [10 \text{ dBm} - (-33 \text{ dBm})] - (3,9 \text{ dB} + 3,9 \text{ dB} + 2,1 \text{ dB}) = 33,1 \text{ dB} \quad (6.28)$$

There are uncertainties in each of these components for the NSA and an example of a typical calculation of the expanded uncertainty is now given. A fully worked example calculation can be found in clause 4 of TR 102 273-1-2 [9].

6.6.1 Uncertainty contribution, direct attenuation measurement

The verification procedure involves two different measurement stages and the derivation of NSA. The first stage (the reference) is with all the items of test equipment connected directly together via an adapter between the attenuators as shown in figure 36 (components shown shaded are common to both stages of the procedure).

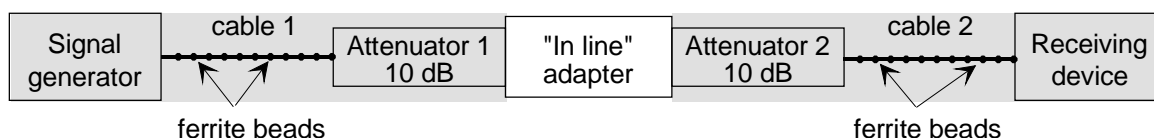

Figure 36: Stage 1: Direct attenuation measurement

Despite the commonality of most of the components to both stages of this procedure, the mismatch uncertainty contribution for both stages has to be calculated and included in the uncertainty calculations, this is the result of load conditions varying (i.e. antennas replacing the adapter in the second stage). Conversely, as a result of this commonality, the uncertainty contributions of some of the individual components will cancel.

The magnitude of the random uncertainty contribution to this stage of the procedure can be assessed from multiple repetition of the direct attenuation measurement. All the uncertainty components which contribute to this stage of the test are listed in table 18. Annex A should be consulted for the sources and/or magnitudes of the uncertainty contributions.

Table 18: Contributions from the direct attenuation measurement

$u_{j \text{ or } i}$	Description of uncertainty contributions	dB
u_{j35}	mismatch: direct attenuation measurement	
u_{j38}	signal generator: absolute output level	
u_{j39}	signal generator: output level stability	
u_{j19}	cable factor: receiving antenna cable	0,00
u_{j19}	cable factor: transmitting antenna cable	0,00
u_{j41}	insertion loss: receiving antenna cable	0,00
u_{j41}	insertion loss: transmitting antenna cable	0,00
u_{j40}	insertion loss: receiving antenna attenuator	0,00
u_{j40}	insertion loss: transmitting antenna attenuator	0,00
u_{j42}	insertion loss: adapter	
u_{j47}	receiving device: absolute level	0,00
u_{j48}	receiving device: linearity	0,00
u_{j01}	random uncertainty (see note in clause A.18 of TR 102 273-1-2 and note in clause 6.4.7 of TR 102 273-1-1)	

The standard uncertainties from table 18 should be combined by RSS in accordance with clause 5 of TR 102 273-1-1 [8]. This gives the combined standard uncertainty ($u_{c \text{ direct attenuation measurement}}$) for the direct attenuation measurement in dB.

6.6.2 Uncertainty contribution, NSA measurement

This stage involves removing the adapter and connecting each attenuator to an antenna as shown in figure 37, and recording the new level on the receiving device.

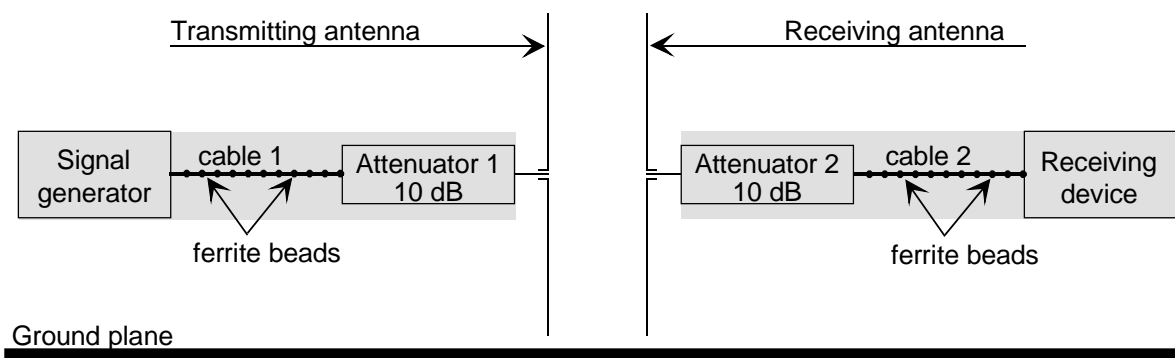

Figure 37: Stage 2: NSA measurement

The difference in received levels (after allowance for any correction factors which may be appropriate), for the same signal generator output level, reveals the NSA. All the uncertainty components which contribute to this stage of the test are listed in table 19. Annex A should be consulted for the sources and/or magnitudes of the uncertainty contributions.

Table 19: Contributions from the NSA actual measurement

$u_{j \text{ or } i}$	Description of uncertainty contributions	dB
u_{j36}	mismatch: transmitting part	
u_{j37}	mismatch: receiving part	
u_{j38}	signal generator: absolute output level	0,00
u_{j39}	signal generator: output level stability	
u_{j19}	cable factor: receiving antenna cable	
u_{j19}	cable factor: transmitting antenna cable	
u_{j41}	insertion loss: receiving antenna cable	0,00
u_{j41}	insertion loss: transmitting antenna cable	0,00
u_{j40}	insertion loss: receiving antenna attenuator	0,00
u_{j40}	insertion loss: transmitting antenna attenuator	0,00
u_{j47}	receiving device: absolute level	
u_{j48}	receiving device: linearity	
u_{j16}	range length	0,00
u_{j18}	correction: measurement distance	0,00
u_{j03}	reflectivity of absorber material: transmitting antenna to the receiving antenna	
u_{j44}	antenna: antenna factor of the receiving antenna	
u_{j44}	antenna: antenna factor of the transmitting antenna	
u_{j46}	antenna: tuning of the receiving antenna	
u_{j46}	antenna: tuning of the transmitting antenna	
u_{j22}	position of the phase centre: receiving antenna	
u_{j22}	position of the phase centre: transmitting antenna	
u_{j17}	correction: off boresight angle in the elevation plane	0,00
u_{j07}	mutual coupling: receiving antenna to its images in the absorbing material	0,00
u_{j07}	mutual coupling: transmitting antenna to its images in the absorbing material	
u_{j15}	mutual coupling: receiving antenna to its images in the ground plane	
u_{j15}	mutual coupling: transmitting antenna to its images in the ground plane	0,00
u_{j10}	mutual coupling: transmitting antenna to the receiving antenna	0,00
u_{j12}	mutual coupling: interpolation of mutual coupling and mismatch loss correction factors	0,00
u_{j34}	ambient effect	0,00
u_{j01}	random uncertainty (see note in clause A.18 of TR 102 273-1-2 and note in clause 6.4.7 of TR 102 273-1-1)	

The standard uncertainties from table 19 should be combined by RSS in accordance with clause 5 of TR 102 273-1-1 [8]. This gives the combined standard uncertainty ($u_{c \text{ NSA measurement}}$) for the NSA measurement in dB.

6.6.3 Expanded uncertainty of the verification procedure

The combined standard uncertainty of the results of the verification procedure is the combination of the components outlined in clauses 6.6.1 and 6.6.2. The components to be combined are $u_{c \text{ direct attenuation measurement}}$ and

$u_{c \text{ NSA measurement}}$

$$u_c = \sqrt{u_{c \text{ direct attenuation measurement}}^2 + u_{c \text{ NSA measurement}}^2} = _, _ \text{ dB} \quad (6.29)$$

The expanded uncertainty is $\pm 1,96 \times u_c = \pm _, _ \text{ dB}$ at a 95 % confidence level.

6.7 Calculation of measurement uncertainty (Procedure 2)

The column headed "Overall" in the results sheet is completed during the processing of the results for the verification procedure. The values entered in this column are the measured NSA figures for the Anechoic Chamber with a Ground Plane.

The value, at any particular frequency, for the measured NSA is "Direct" (reference value) less "Site" (the value appearing on the receiver during the NSA measurement) less the sum of "Transmit Antenna factor AF_T " and "Receive Antenna factor AF_R " i.e.:

$$\text{NSA} = \text{"Direct"} - \text{"Site"} - \text{"Transmit Antenna factor"} - \text{"Receive Antenna factor"} \quad (6.30)$$

As an example, let the direct attenuation value be 10 dBm and the received level during the site measurement be -33 dBm. Putting each antenna factor at 3,9 dB gives a measured NSA value of:

$$\text{NSA} = [10 \text{ dBm} - (-33 \text{ dBm})] - (7,8 \text{ dB}) = 35,2 \text{ dB} \quad (6.31)$$

There are uncertainties in each of these components for the NSA and an example of a typical calculation of the expanded uncertainty is now given. A fully worked example calculation can be found in TR 102 273-1-1 [8], clause 11.

6.7.1 Uncertainty contribution, direct attenuation measurement

The verification procedure involves two different measurement stages and the derivation of NSA. The first stage (the reference) is with all the items of test equipment connected directly together via an adapter between the attenuators as shown in figure 38 (components shown shaded are common to both stages of the procedure).

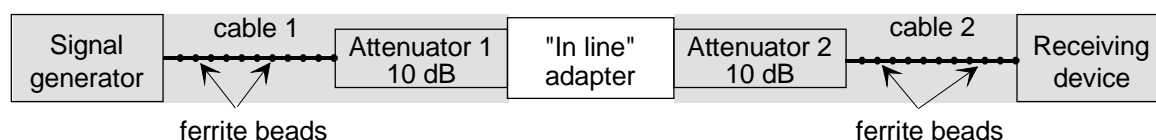

Figure 38: Stage 1: Direct attenuation measurement

Despite the commonality of most of the components to both stages of this procedure, the mismatch uncertainty contribution for both stages of the test has to be calculated and included in the uncertainty calculations. This is the result of load conditions varying (i.e. antennas replacing the adapter in the second stage). Conversely, as a result of this commonality, the uncertainty contributions of some of the individual components will cancel.

The magnitude of the random uncertainty contribution to this stage of the procedure can be assessed from multiple repetition of the direct attenuation measurement. All the uncertainty components which contribute to this stage of the test are listed in table 20. Annex A should be consulted for the sources and/or magnitudes of the uncertainty contributions.

Table 20: Contributions from the direct attenuation measurement

$u_{j \text{ or } i}$	Description of uncertainty contributions	dB
u_{j35}	mismatch: direct attenuation measurement	
u_{j38}	signal generator: absolute output level	
u_{j39}	signal generator: output level stability	
u_{j19}	cable factor: receiving LPDA cable	0,00
u_{j19}	cable factor: transmitting LPDA cable	0,00
u_{j41}	insertion loss: receiving LPDA cable	0,00
u_{j41}	insertion loss: transmitting LPDA cable	0,00
u_{j40}	insertion loss: receiving LPDA attenuator	0,00
u_{j40}	insertion loss: transmitting LPDA attenuator	0,00
u_{j42}	insertion loss: adapter	
u_{j47}	receiving device: absolute level	0,00
u_{j48}	receiving device: linearity	0,00
u_{j01}	random uncertainty (see note in clause A.18 of TR 102 273-1-2 and note in clause 6.4.7 of TR 102 273-1-1)	

The standard uncertainties from table 20 should be combined by RSS in accordance with clause 5 of TR 102 273-1-1 [8]. This gives the combined standard uncertainty (u_c direct attenuation measurement) for the direct attenuation measurement in dB.

6.7.2 Uncertainty contribution, NSA measurement

This stage involves removing the adapter and connecting each attenuator to an antenna as shown in figure 39, and recording the new level on the receiving device.

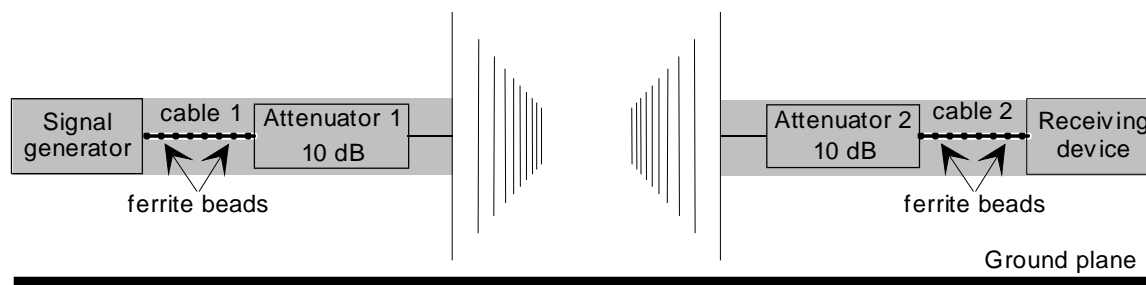
**Figure 39: Stage 2: NSA measurement**

The difference in received levels (after allowance for any correction factors which may be appropriate), for the same signal generator output level, reveals the NSA. All the components which contribute to this stage of the test are listed in table 21. Annex A should be consulted for the sources and/or magnitudes of the uncertainty contributions.

Table 21: Contributions from the measurement

$u_{j \text{ or } i}$	Description of uncertainty contributions	dB
u_{j36}	mismatch: transmitting part	
u_{j37}	mismatch: receiving part	
u_{j38}	signal generator: absolute output level	0,00
u_{j39}	signal generator: output level stability	
u_{j19}	cable factor: receiving LPDA cable	
u_{j19}	cable factor: transmitting LPDA cable	
u_{j41}	insertion loss: receiving LPDA cable	0,00
u_{j41}	insertion loss: transmitting LPDA cable	0,00
u_{j40}	insertion loss: receiving LPDA attenuator	0,00
u_{j40}	insertion loss: transmitting LPDA attenuator	0,00
u_{j47}	receiving device: absolute level	
u_{j48}	receiving device: linearity	
u_{j16}	range length	0,00
u_{j18}	correction: measurement distance	0,00
u_{j03}	reflectivity of absorbing material: transmitting LPDA to the receiving LPDA	
u_{j44}	antenna: antenna factor of the receiving LPDA	
u_{j44}	antenna: antenna factor of the transmitting LPDA	
u_{j22}	position of the phase centre: receiving LPDA	
u_{j22}	position of the phase centre: transmitting LPDA	
u_{j23}	position of the phase centre: LPDA	
u_{j17}	correction: off boresight angle in the elevation plane	
u_{j07}	mutual coupling: receiving LPDA to its images in the absorbing material	
u_{j07}	mutual coupling: transmitting LPDA to its images in the absorbing material	
u_{j15}	mutual coupling: receiving LPDA to its image in the ground plane	
u_{j15}	mutual coupling: transmitting LPDA to its image in the ground plane	
u_{j34}	ambient effect	0,00
u_{j01}	random uncertainty (see note in clause A.18 of TR 102 273-1-2 and note in clause 6.4.7 of TR 102 273-1-1)	

The standard uncertainties from table 21 should be combined by RSS in accordance with clause 5 of TR 102 273-1-1 [8]. This gives the combined standard uncertainty (u_c NSA measurement) for the NSA measurement of in dB.

6.7.3 Expanded uncertainty of the verification procedure

The combined standard uncertainty of the results of the verification procedure is the combination of the components outlined in clauses 6.7.1 and 6.7.2. The components to be combined are u_c direct attenuation measurement and

u_c NSA measurement

$$u_c = \sqrt{u_{c \text{ direct attenuation measurement}}^2 + u_{c \text{ NSA measurement}}^2} = _, _ \text{ dB} \quad (6.32)$$

The expanded uncertainty is $\pm 1,96 \times u_c = \pm _, _ \text{ dB}$ at a 95 % confidence level.

6.8 Summary

The expanded uncertainty values derived in clauses 6.6.3 and 6.7.3 reveal the uncertainty with which the NSA can be measured. Any value of NSA which varies by more than these uncertainty values from the theoretical value is probably due to imperfection(s) in the site. These imperfections may be due to reflections from a range of possible sources in the Anechoic Chamber with a Ground Plane at the time the verification procedure is carried out.

7 Test methods

7.1 Introduction

The following test methods apply to integral antenna devices only i.e. EUTs not fitted with either a permanent or a temporary external antenna connector. The spurious emission test also applies to EUTs with a detachable antenna.

The range length of the Anechoic Chamber with a Ground Plane should be adequate to allow for testing in the far-field of the EUT i.e. the range length should be equal to or exceed:

$$\frac{2(d_1 + d_2)^2}{\lambda} \quad (7.1)$$

where:

d_1 is the largest dimension of the EUT/dipole after substitution (m);

d_2 is the largest dimension of the test antenna (m);

λ is the test frequency wavelength (m).

It should be noted that in the substitution part of these tests, where both test and substitution/measuring antennas are half wavelength dipoles, this minimum range length for far-field testing is:

$$2\lambda$$

It should be stated in the test report when either of these conditions is not met. The additional contributions to the measurement uncertainty which result can be incorporated into the analysis of the results.

The chamber should offer a full height scanning capability, i.e. 1 m to 4 m for which no part of the test antenna should come within 1 m of the absorbing panels (this is to avoid "electrical loading"). Equally, during rotation no part of the EUT should come within 1 m of the absorbing panels. Where either of these conditions cannot be met, the measurement should not be carried out.

Further, measurements should not be carried out if the reflectivity of the absorbing material within the chamber is worse than -5 dB at the frequency of test.

7.1.1 Site preparation

The cables for both ends of the test chamber should be routed, where possible, parallel to or coincident with the plane of symmetry of the chamber (see figure 30) and parallel to the floor. They should run behind and away from the antennas towards the end walls for a minimum of 2 m (unless the end wall is reached). They should then be allowed to drop vertically towards the floor, preferably behind the anechoic panels, and routed out through the screen (normally via a breakout panel) to the test equipment.

These cables should be dressed with ferrite beads, spaced 0,15 m apart for their entire lengths above the ground plane.

NOTE: Where a cable drum is incorporated with the antenna mast, the routing requirement and ferrite beading of the cables may be impossible to comply with. In such cases increased measurement uncertainty results.

The routing and dressing of the cables should be identical to the verification procedure set-up.

Calibration data for all items of test equipment used should be available and valid. For both the test and substitution/measuring antennas, the data should include gain relative to an isotropic radiator (or antenna factor) against frequency. Also, the VSWR of the substitution/measuring antenna should be known.

The calibration data for all cables and attenuators used should include insertion loss and VSWR throughout the entire frequency range of the tests. All VSWR and insertion loss figures should be recorded in the log book results sheet for the specific test.

Where correction factors/tables are required, these should be immediately available.

For all items of test equipment, the maximum uncertainties they exhibit should be known along with the distribution of the error e.g.:

- cable loss: $\pm 0,5$ dB with a rectangular distribution;
- measuring receiver: 1,0 dB (standard deviation) signal level accuracy with a Gaussian error distribution.

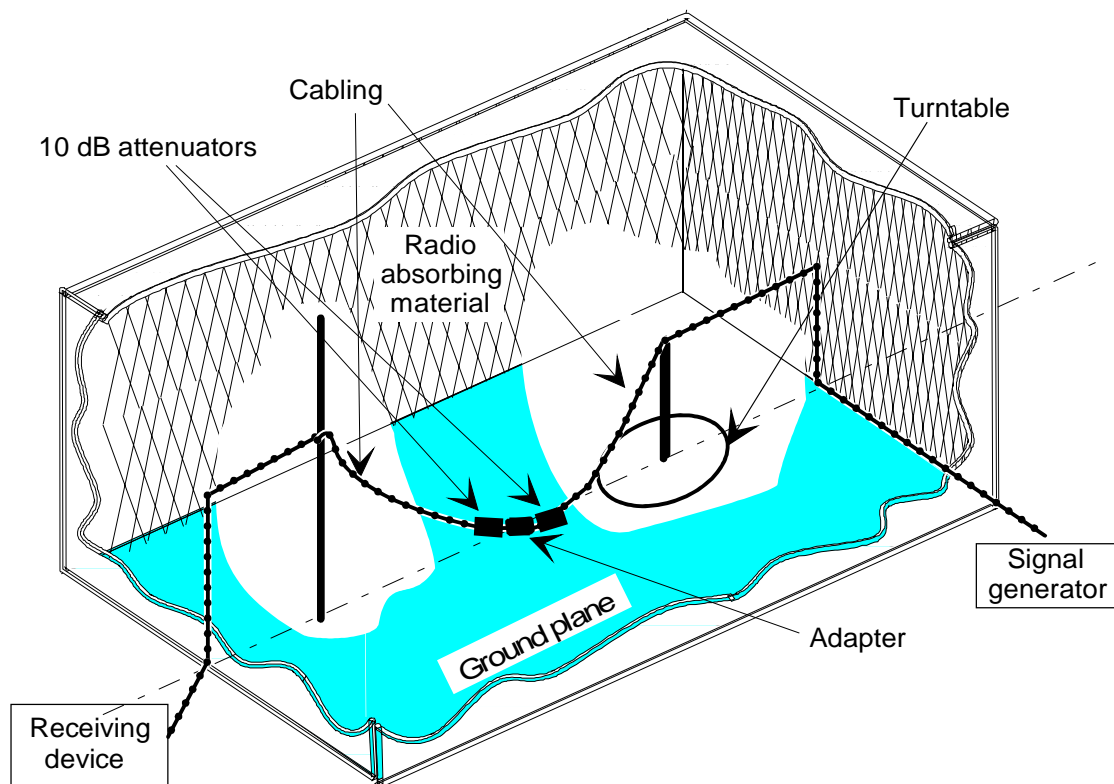

Figure 40: Anechoic Chamber with a Ground Plane set-up for daily system checking

At the start of each day, system checks should be performed on the test equipment used in the Anechoic Chamber with a Ground Plane. The following checking procedures, as a minimum requirement, should be carried out.

- 1) All items of test equipment requiring electrical supplies should be connected to their power sources, switched on and allowed adequate time to stabilize, as recommended by the manufacturers. Where a stabilization period is not given by the manufacturer, 30 minutes should be allowed. After this time period those items of test equipment which possess the facility should have their self test/self calibration procedures performed.
- 2) A signal generator should be connected to the existing cabling at the turntable end. The other end of this cable should be connected via a calibrated coaxial cable/10 dB attenuator/adapter/10 dB attenuator/calibrated coaxial cable combination to existing cabling at the other end of the chamber. This existing cable should be connected to a receiving device (see figure 40). Where the use of a cable is impractical due to the arrangements within the chamber, bicones or other suitable antennas could be connected at both ends as appropriate. The signal generator should be scanned across the appropriate frequency range and the response of the receiving device noted. It should be compared with previous tests carried out under similar conditions. Any anomalies should be investigated.

7.1.2 Preparation of the EUT

The manufacturer should supply information about the EUT covering the operating frequency, polarization, supply voltage(s) and the reference face. Additional information, specific to the type of EUT should include, where relevant, carrier power, channel spacing, whether different operating modes are available (e.g. high and low power modes) and if operation is continuous or is subject to a maximum test duty cycle (e.g. 1 minute on, 4 minutes off).

Where necessary, a mounting bracket of minimal size should be available for mounting the EUT on the turntable. This bracket should be made from low conductivity, low relative dielectric constant (i.e. less than 1,5) material(s) such as expanded polystyrene, balsawood, etc.

The presence of the cables supplying power can affect the measured performance of the EUT. For this reason, attempts should be made to make them "transparent" as far as the testing is concerned. This can be achieved by routing them by the shortest possible paths down to, and through, the ground plane. Additionally, where possible, these leads should be twisted together and loaded with ferrite beads at 0,15 m spacing.

7.1.3 Standard antennas

In the frequency band 30 MHz to 1 000 MHz, except where stipulated, both test and substitution/measuring antennas should be tuned half-wavelength dipoles (constructed as detailed in ANSI C63.5 [1]) aligned for the same polarization.

NOTE: Due to size constraints a shortened dipole is used over part of this frequency band. For uniformity of procedures across Open Area Test Sites and both types of Anechoic Chamber, a shortened dipole is used from 30 up to 80 MHz. At all these frequencies the 80 MHz arm length (0,889 m) is used attached to the 20 MHz to 65 MHz balun for all test frequencies from 30 MHz to 65 MHz inclusive and to the 65 MHz to 180 MHz balun for 65 MHz to 80 MHz. Tuned half wavelength dipoles, attached to their matching baluns are used for all frequencies in the band 80 MHz to 1 000 MHz inclusive. Table 22 details dipole arm lengths (as measured from the centre of the balun block) and balun type against frequency. Where the test frequency does not correspond to a set frequency in the table, the arm length to be used should be determined by linear interpolation between the closest set values.

Table 22: Dipole arm length and balun type against frequency

Frequency (MHz)	Dipole arm length (m)	Balun type	Frequency (MHz)	Dipole arm length (m)	Balun type
30	0,889	20 MHz to 65 MHz	160	0,440	65 MHz to 180 MHz
35	0,889		180	0,391	
40	0,889		200	0,352	180 MHz to 400 MHz
45	0,889		250	0,283	
50	0,889		300	0,235	
60	0,889		400	0,175	
70	0,889	65 MHz to 180 MHz	500	0,143	400 MHz to 1 000 MHz
80	0,889		600	0,117	
90	0,791		700	0,102	
100	0,714		800	0,089	
120	0,593		900	0,079	
140	0,508		1 000	0,076	

7.1.4 Mutual coupling and mismatch loss correction factors

Correction factors are included where relevant, to allow for mutual coupling and mismatch loss for the 30 MHz to 180 MHz band, based on using the recommended ANSI C63.5 [1] dipoles. These have been calculated by computer modelling of their baluns, sectional arms and the testing arrangements (i.e. range length and optimized height above the ground plane) using MiniNEC. The factors are only valid for this particular type of dipole. However, if this type is unavailable, an alternative could be used. This alternative should be a tuned half wavelength dipole at the particular test frequency. Since correction factors have not been calculated in the present document for any type other than the ANSI C63.5 [1] dipoles this will result in a greater expanded uncertainty for the measurement unless the test house/manufacturer has performed equivalent modelling on the dipoles used.

7.1.5 Power supplies to the EUT

All tests should be performed using power supplies wherever possible, including tests on EUTs designed for battery-only use. In all cases, power leads should be connected to the EUTs supply terminals (and monitored with a digital voltmeter) but the battery should remain present, electrically isolated from the rest of the EUT, possibly by putting tape over its contacts. All leads involved should be taken down to the floor of the facility by the shortest possible routes, twisting pairs together and loading with ferrite beads at 0,15 m spacing.

7.1.6 Restrictions

The restriction that no part of any antenna or EUT should come within 1 m of any part of the absorbing panels or within 0,25 m of the ground plane should be applied at all times throughout these test methods.

7.2 Transmitter tests

7.2.1 Frequency error (30 MHz to 1 000 MHz)

Definition

The frequency error of a transmitter is the difference between the measured carrier frequency in the absence of modulation and the nominal frequency of the transmitter as stated by the manufacturer.

7.2.1.1 Apparatus required

- digital voltmeter;
- ferrite beads;
- 10 dB attenuators;
- power supply;
- connecting cables;
- Anechoic Chamber with a Ground Plane;
- test antenna (a half wavelength dipole, a bicone or an LPDA);
- frequency counter.

The type and serial numbers of all items of test equipment should be recorded in the log book results sheet (see table 23).

NOTE: The half wavelength dipole antennas, incorporating matching/transforming baluns, for the procedure are available in the following bands: 20 MHz to 65 MHz, 65 MHz to 180 MHz, 180 MHz to 400 MHz, 400 MHz to 1 000 MHz. Constructional details are contained in ANSI C63.5 [1]. In the recommended antenna scheme for this band, a shortened dipole is used at all frequencies from 30 MHz up to 80 MHz.

7.2.1.2 Method of measurement

- 1) The measurement should always be performed in the absence of modulation.
- 2) The EUT should be mounted on a turntable whose mounting surface is at the height (above the ground plane) specified in the relevant standard. The EUT should be mounted in an orientation which matches that of its normal usage as stated by the manufacturer. This orientation and mounting configuration should be recorded in the log book results sheet (see table 23).

NOTE 1: The turntable should be constructed from non-conducting, low relative dielectric constant (preferably less than 1,5) material(s).

- 3) The test antenna (dipole, bicone or LPDA) should be mounted on the antenna mast and oriented for the stated polarization of the EUT. For cases in which the test antenna is a tuned half wavelength dipole, this should be tuned to the nominal frequency. The output of the test antenna should be connected to the frequency counter via a 10 dB attenuator and the calibrated, ferrited coaxial cable associated with that end of the chamber (see figure 41). The phase centre of the test antenna should be at the same height above the floor as the mid point of the EUT.

NOTE 2: Where a dipole is used, frequencies below 80 MHz require a shortened version (as defined in clause 7.1.3) to be used. For any frequency, the dipole arm length (given in table 22) is defined from the centre of the balun block to the tip of the arm. From a fully extended state, each telescopic element, in turn, should be "pushed in" from the tip until the required length is obtained. The outermost section needs to fully compress before any of the others, and so on. Table 22 also gives the choice of balun for set frequencies. Where the test frequency does not correspond to a set frequency in the table, the arm length to be used should be determined by linear interpolation between the closest set values.

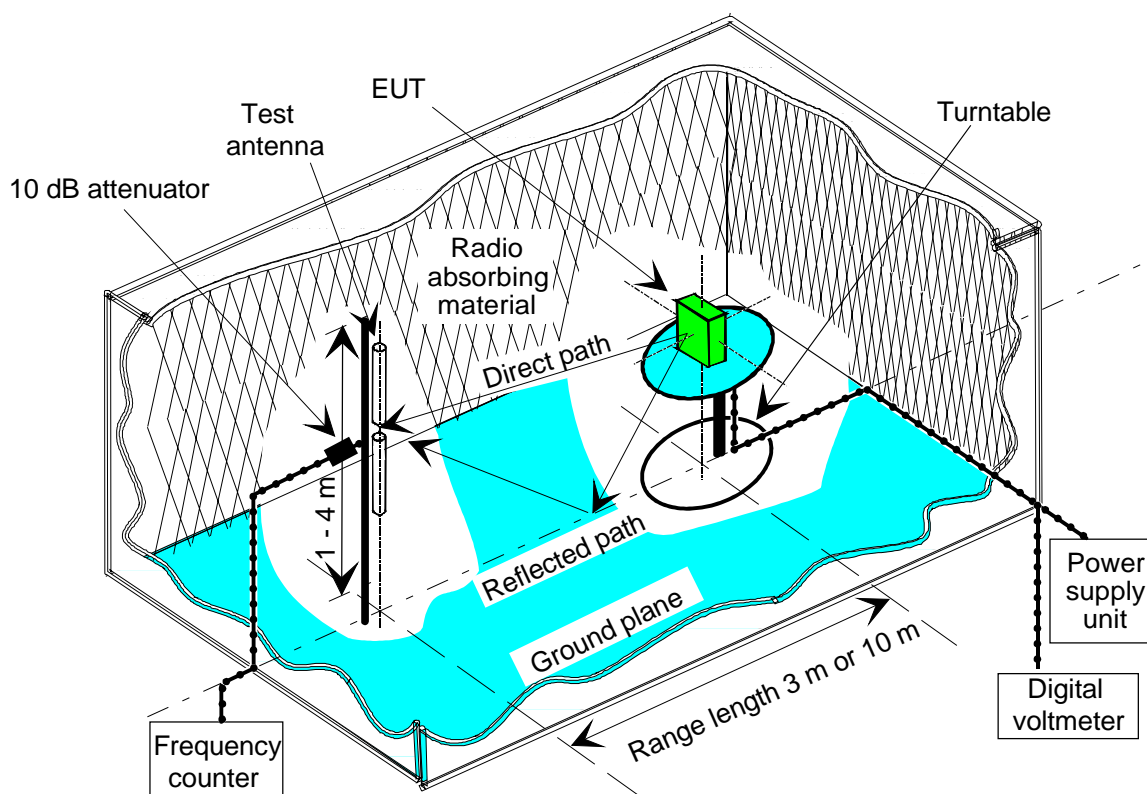

Figure 41: Anechoic Chamber with a Ground Plane set-up for the Frequency error test

- 4) The EUT should be switched on without modulation, allowed adequate time to stabilize and the resolution of the frequency counter adjusted to read to the nearest Hz.
- 5) For cases in which no reading is given on the frequency counter, the height of the test antenna on the mast should be varied until a reading does appear.
- 6) The value of the frequency displayed on the counter should be recorded in the log book results sheet (see table 23).

NOTE 3: In cases where the frequency does not appear stable, this might require observations over a 30 second or 1 minute time period, noting the highest and lowest readings and estimating the average value. In these cases it is the average value that should be recorded in the log book results sheet (see table 23).

7.2.1.3 Procedure for completion of the overall results sheet

There are two values that need to be derived before the overall results sheet (see table 24) can be completed. Firstly the value for frequency error (from a straightforward calculation of recorded frequency minus the nominal frequency) and secondly, the value of the expanded uncertainty for the test. This should be carried out as given in clause 7.2.2 and the resulting value entered in the overall results sheet (see table 24).

7.2.1.4 Log book entries

Table 23: Log book results sheet

FREQUENCY ERROR			Date:	PAGE 1 of 1		
Temperature:.....°C		Humidity:.....%		Frequency:.....MHz		
Manufacturer of EUT:.....		Type No:.....		Serial No:.....		
Range length:.....						
Test equipment item	Type No.	Serial No.	VSWR	Insertion loss	Antenna factor/gain	
Test antenna				N/A		
Test antenna attenuator					N/A	
Test antenna cable					N/A	
Digital voltmeter			N/A	N/A	N/A	
Power supply			N/A	N/A	N/A	
Ferrite beads			N/A	N/A	N/A	
Frequency counter				N/A	N/A	
Mounting configuration of EUT						
Reading on frequency counter:			Hz			

7.2.1.5 Statement of results

The results should be presented in tabular form as shown in table 24.

Table 24: Overall results sheet

FREQUENCY ERROR		Date:	PAGE 1 of 1
Frequency error		Hz	
Expanded uncertainty (95 %)		dB	

7.2.2 Expanded uncertainty for Frequency error test

The method of calculating the expanded uncertainty for tests in which signal levels in dB are involved is equally adopted for the frequency error test in which all the uncertainties are in the units of Hz. That is, all the uncertainty contributions are converted into standard uncertainties and combined by the RSS method under the assumption that they are all stochastic. All the uncertainty components which contribute to the test are listed in table 25. Annex A should be consulted for the sources and/or magnitudes of the uncertainty contributions.

Table 25: Contributions from the measurement

$u_{j \text{ or } i}$	Description of uncertainty contributions	Hz
u_{j01}	random uncertainty (see note in clause A.18 of TR 102 273-1-2 and note in clause 6.4.7 of TR 102 273-1-1)	
u_{j56}	frequency counter: absolute reading	
u_{j05}	mutual coupling: detuning effect of the absorbing material on the EUT	
u_{j09}	mutual coupling: detuning effect of the test antenna on the EUT	

The standard uncertainties from table 25 should be combined by RSS in accordance with clause 5 of TR 102 273-1-1 [8]. The combined standard uncertainty of the frequency measurement (u_c contributions from the measurement) is the combination of the components outlined above.

$$u_c = \text{uc contributions from the measurement} = \text{___, ___ Hz} \quad (7.2)$$

The expanded uncertainty is $\pm 1,96 \times u_c = \pm \text{___, ___ Hz}$ at a 95 % confidence level.

7.2.3 Effective radiated power (30 MHz to 1 000 MHz)

Definition

The effective radiated power is the power radiated in the direction of the maximum field strength under specified conditions of measurement, in the absence of modulation.

7.2.3.1 Apparatus required

- digital voltmeter;
- ferrite beads;
- 10 dB attenuators;
- power supply;
- connecting cables;
- Anechoic Chamber with a Ground Plane;
- test antenna (half wavelength dipole as detailed in ANSI C63.5 [1] recommended);
- substitution antenna (half wavelength dipole as detailed in ANSI C63.5 [1] recommended);
- receiving device (measuring receiver or spectrum analyser);
- signal generator.

The type and serial numbers of all items of test equipment should be recorded on page 1 of the log book results sheet (see table 27).

NOTE: The half wavelength dipole antennas, incorporating matching/transforming baluns, for the procedure are available in the following bands: 20 MHz to 65 MHz, 65 MHz to 180 MHz, 180 MHz to 400 MHz, 400 MHz to 1 000 MHz. Constructional details are contained in ANSI C63.5 [1]. In the recommended antenna scheme for this band, a shortened dipole is used at all frequencies from 30 MHz up to 80 MHz.

7.2.3.2 Method of measurement

- 1) The measurement should always be performed in the absence of modulation.
- 2) The EUT should be mounted directly onto the turntable, whose surface is at the height (above the ground plane) specified in the relevant standard, in an orientation which matches that of its normal usage (as stated by the manufacturer). The normal to the reference face of the EUT should point directly down the chamber towards the antenna mast. This is the 0° reference angle for the test. This orientation and mounting configuration should be recorded on page 1 of the log book results sheet (see table 27). The items of test equipment should be set-up as shown in figure 42.

NOTE 1: The turntable should be constructed from non-conducting, low relative dielectric constant (preferably less than 1,5) material(s).

- 3) In cases where the position of the phase centre of the EUT's antenna is known, the EUT should be positioned on the turntable such that this phase centre is as coincident with the axis of rotation as possible. Alternatively, if the position of the phase centre is unknown but the antenna is a single rod which is visible and vertical in normal usage, the axis of the antenna should be used. If neither alternative is possible, the volume centre of the EUT should be used instead.
- 4) The height above the ground plane of the phase centre (if known) of the EUT should be recorded on page 1 of the log book results sheet (see table 27). If the position of the phase centre is unknown but the antenna is visible, then the height above the ground plane of the point at which the antenna meets the case of the EUT should be recorded. If neither alternative is possible the volume centre of the EUT should be used instead.
- 5) The test antenna (in the recommended scheme a tuned ANSI C63.5 [1] half wavelength dipole for frequencies of 80 MHz and above, a shortened dipole for frequencies from 30 MHz up to 80 MHz) should be mounted on the antenna mast, tuned to the appropriate frequency and oriented for vertical polarization. Its output should be connected to the receiving device via a 10 dB attenuator and the calibrated, ferrited coaxial cable associated with that end of the chamber.

NOTE 2: For all frequencies below 80 MHz, a shortened dipole (as defined in clause 7.1.3) should be used. The dipole arm length is defined from the centre of the balun block to the tip of the arm. From a fully extended state, each telescopic element, in turn, should be "pushed in" from the tip until the required length is obtained. The outermost section needs to fully compress before any of the others, and so on. Table 22 gives the dipole arm lengths and choice of balun for set frequencies. Where the test frequency does not correspond to a set frequency in the table, the arm length to be used should be determined by linear interpolation between the closest set values.

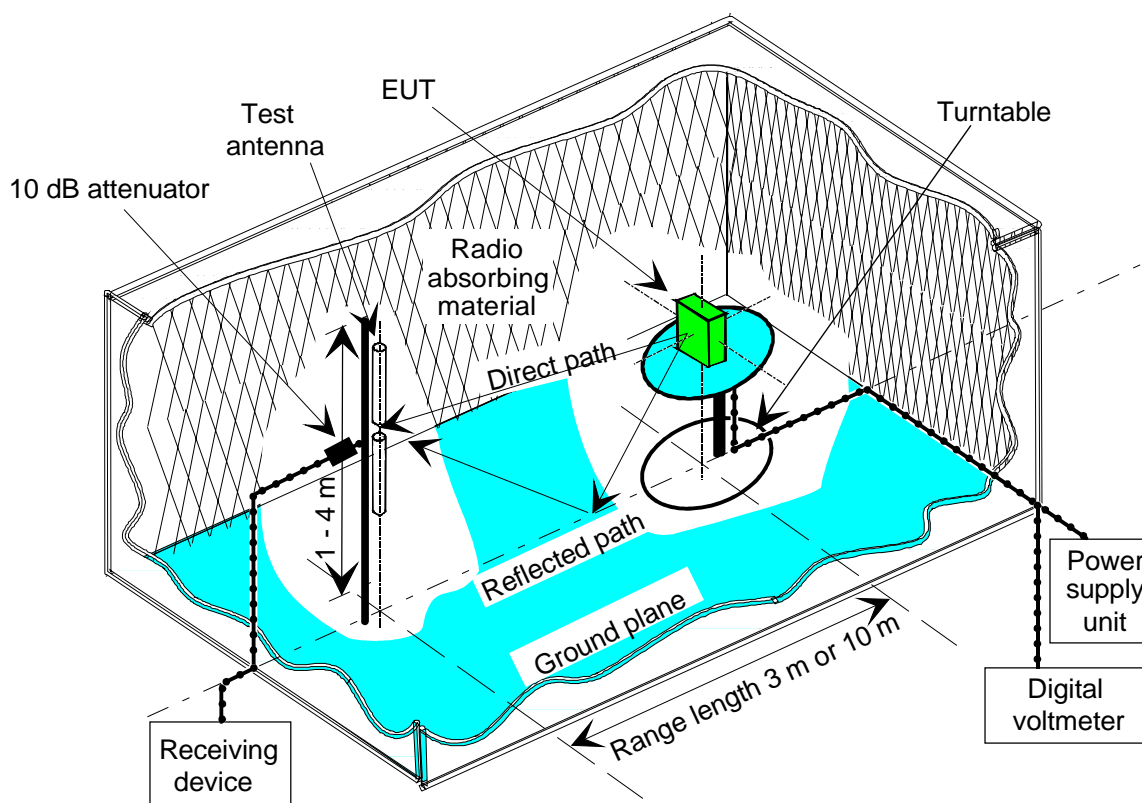

Figure 42: Anechoic Chamber with a Ground Plane set-up for the Effective radiated power measurement on the EUT

- 6) The EUT should be switched on without modulation, and the receiving device tuned to the appropriate frequency.
- 7) The test antenna should be raised and lowered through the specified range of heights (1 m to 4 m, ensuring that no part of the antenna is less than 0,25 m from the ground plane at any time) until the maximum signal level is detected on the receiving device. The height of the test antenna on the mast should be recorded on page 2 of the log book results sheet (see table 27).

NOTE 3: The true maximum may lie beyond the top of the mast, in which case the maximum receivable level should be at the top of the height range.

- 8) The EUT should be rotated through 360° in the horizontal plane until the maximum signal is detected on the receiving device. The angle with reference to the nominal orientation of the EUT and the maximum signal level (dBm) detected by the receiving device should be recorded on page 1 of the log book results sheet (see table 27).
- 9) The EUT should be replaced on the turntable by the substitution antenna (identical to the test antenna), which has been adjusted to correspond to the frequency of the EUT. See figure 43.
- 10) The height of the phase centre of the substitution antenna should be located at the height recorded in step 4 whilst the phase centre should lie on the axis of rotation of the turntable.
- 11) The substitution antenna should be oriented for vertical polarization and connected via a 10 dB attenuator to a calibrated signal generator using the calibrated, ferrited coaxial cable associated with the turntable end of the chamber.
- 12) The signal generator should be tuned to the appropriate frequency and its output level adjusted until the level measured on the receiving device, is at least 20 dB above the level with the output from the signal generator switched off.
- 13) The test antenna should be raised and lowered through the specified range of heights until the maximum signal level is achieved on the receiving device. The height of the test antenna on the mast should be recorded on page 2 of the log book results sheet (see table 27).

NOTE 4: The true maximum may lie beyond the top of the mast, in which case the maximum received level should be at the top of the height range.

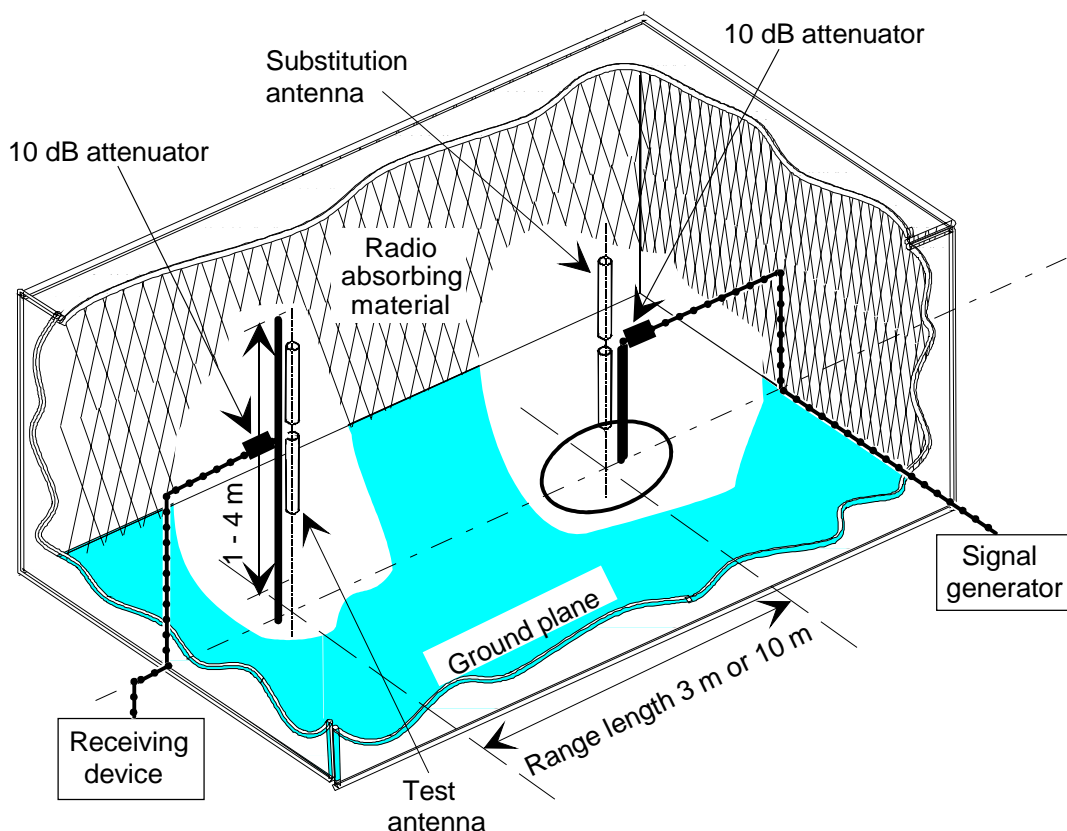

Figure 43: Anechoic Chamber with a Ground Plane set-up for the Effective radiated power substitution measurement

14) The substitution antenna should be rotated until the maximum level is detected on the receiving device.

NOTE 5: This is to correct for possible misalignment of a directional beam i.e. dipoles used in horizontally polarized tests. This step can be omitted when dipoles are used in vertically polarized tests.

15) The output level of the signal generator should be adjusted until the level, measured on the receiving device, is identical to that recorded in Step 8. This output signal level (dBm) from the signal generator should be recorded on page 2 of the log book results sheet (see table 27).

NOTE 6: In the event of insufficient range of signal generator output level, the receiving device input attenuation should be decreased to compensate. The signal generator output level (dBm) and the change in attenuation (dB) should both be recorded on page 2 of the log book results sheet (see table 27) in this case.

16) The EUT should be remounted on the turntable as stipulated in Steps 2, 3 and 4, the test antenna oriented for horizontal polarization and Steps 5 to 15 repeated with the substitution antenna also oriented for horizontal polarization.

7.2.3.3 Procedure for completion of the overall results sheet

There are two values that need to be derived before the overall results sheet (see table 28) can be completed. These are the overall measurement correction and the expanded uncertainty values.

Guidance for deriving the values of the correction factors is given in table 26.

When the correction factors have been derived, they should be entered on page 2 of the log book results sheet (see table 27) as a result of which the overall correction can be calculated as follows:

overall correction factor (dB) = substitution antenna cable loss
 + substitution antenna attenuator loss
 + substitution antenna balun loss
 + mutual coupling and mismatch loss (where applicable)
 + correction for measurement distance
 + correction off-boresight elevation angles
 - gain of substitution antenna

NOTE: For frequencies greater than 180 MHz the mutual coupling and mismatch loss factor should be taken as 0,00 dB

The resulting value for the overall correction factor should then be entered on page 2 of the log book result sheet (see table 27). The effective radiated power can then be calculated:

effective radiated power (dBm) = signal generator output level
 - reduction in the input attenuation of receiving device (if any)
 + overall correction factor

The only calculation that remains to be performed before the overall results sheet (see table 28) can be completed is the determination of the expanded measurement uncertainty. This should be carried out as given in clause 7.2.4 and the resulting value entered in the overall results sheet (see table 28).

Table 26: Guidance for deriving correction factors

Figures for correction factors	
Substitution antenna cable loss	Obtained from calibration data
Substitution antenna attenuator loss	Obtained from calibration data
Substitution antenna balun loss	If not known from calibration, the value should be taken as 0,3 dB
Mutual coupling and mismatch loss correction factors between the test antenna and the substitution antenna	For ANSI dipoles (30 MHz to 180 MHz) can be obtained from TR 102 273-1-2 [9], table A.20. For frequencies greater than 180 MHz, this value is 0,00 dB. For non-ANSI dipoles this value is 0,00 dB
Measurement distance	(only for different heights of the test antenna). The correction is the difference between the values for the 2 heights in the 2 stages of the test. A value for each height should be taken from TR 102 273-1-2 [9] figure A.7. Value 1 (height for the measurement on the EUT).....dB Value 2 (height for the substitution measurement).....dB Correction value is: (value 2 - value 1) dB
Off boresight angle in elevation plane (for vertically polarized case only)	(only for different heights of the test antenna). The correction factor is the difference between the values for the 2 heights in the 2 stages of the test. A value for each height should be taken from TR 102 273-1-2 [9] figure A.8. Value 1 (height for the measurement on the EUT).....dB Value 2 (height for the substitution measurement).....dB Correction value is: (value 2 - value 1) dB
Gain of substitution antenna	2,10 dBi for ANSI dipoles (30 MHz to 1 000 MHz). For other types the value can be obtained from calibration data
NOTE: For horizontally polarized tests this is 0,00 dB.	

7.2.3.4 Log book entries

Table 27: Log book results sheet

EFFECTIVE RADIATED POWER			Date:	PAGE 1 of 2		
Temperature:.....°C		Humidity:.....%		Frequency:.....MHz		
Manufacturer of EUT:.....		Type No:.....		Serial No:.....		
Bandwidth of Receiving Device.....Hz						
Range length:.....						
Test equipment item	Type No.	Serial No.	VSWR	Insertion loss	Antenna factor/gain	
Test antenna				N/A		
Test antenna attenuator					N/A	
Test antenna cable					N/A	
Substitution antenna				N/A		
Substitution antenna attenuator					N/A	
Substitution antenna cable					N/A	
Digital voltmeter			N/A	N/A	N/A	
Power supply			N/A	N/A	N/A	
Receiver device				N/A	N/A	
Signal generator				N/A	N/A	
Ferrite beads			N/A	N/A	N/A	
Mounting configuration of EUT						

(continued)

Table 27(concluded): Log book results sheet

EFFECTIVE RADIATED POWER		Date:	PAGE 2 of 2
Vertical Polarization		Horizontal Polarization	
Height of the phase centre, antenna attachment point or volume centre of the EUT		Height of the phase centre, antenna attachment point or volume centre of the EUT	
Height of test antenna (EUT measurement)		Height of test antenna (EUT measurement)	
Maximum signal level on receiving device	dBm	Maximum signal level on receiving device (dBm)	dBm
Angle at which the maximum signal is received		Angle at which the maximum signal is received	
Height of test antenna (substitution measurement)		Height of test antenna (substitution measurement)	
Output level from signal generator into substitution antenna	dBm	Output level from signal generator into substitution antenna	dBm
Change in receiver attenuator	dB	Change in receiver attenuator	dB
Correction factors			
Substitution antenna cable loss		Substitution antenna cable loss	
Substitution antenna attenuator loss		Substitution antenna attenuator loss	
Substitution antenna balun loss		Substitution antenna balun loss	
Mutual coupling and mismatch loss (30 MHz to 180 MHz)		Mutual coupling and mismatch loss (30 MHz to 180 MHz)	
Measurement distance		Measurement distance	
Off boresight in elevation plane		Off boresight in elevation plane	
Gain of the substitution antenna		Gain of the substitution antenna	
Overall correction factor	dB	Overall correction factor	dB

7.2.3.5 Statement of results

The results should be presented in tabular form as shown in table 28.

Table 28: Overall results sheet

EFFECTIVE RADIATED POWER		Date:	PAGE 1 of 1
Vertical polarization		Horizontal polarization	
Effective radiated power	dBm	Effective radiated power	dBm
Expanded uncertainty (95 %)	dB	Expanded uncertainty (95 %)	dB

7.2.4 Measurement uncertainty for Effective radiated power

A fully worked example illustrating the methodology to be used can be found in clause 4 of TR 102 273-1-2 [9].

7.2.4.1 Uncertainty contributions: Stage one: EUT measurement

For the measurement of effective radiated power two stages of test are involved. The first stage (the EUT measurement) is to measure on the receiving device, a level from the EUT as shown in figure 44 (shaded components are common to both stages of the test).

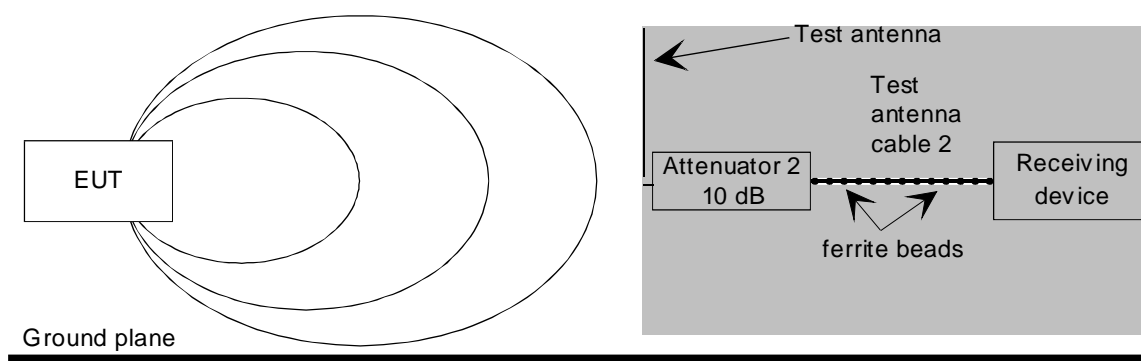

Figure 44: Stage 1: EUT measurement

Due to the commonality of all of the components from the test antenna to the receiver in both stages of the test, the mismatch uncertainty contributes identically to both stages and hence cancels. Similarly, the systematic uncertainty contributions (e.g. test antenna cable loss, etc.) of the individual components also cancel.

The magnitude of the random uncertainty contribution to this stage of the procedure can be assessed from multiple repetition of the EUT measurement. All the uncertainty components which contribute to this stage of the test are listed in table 29. Annex A should be consulted for the sources and/or magnitudes of the uncertainty contributions.

Table 29: Contributions from the EUT measurement

u_j or i	Description of uncertainty contributions	dB
u_{j37}	mismatch: receiving part	
u_{j19}	cable factor: test antenna cable	0,00
u_{j41}	insertion loss: test antenna cable	0,00
u_{j40}	insertion loss: test antenna attenuator	0,00
u_{j47}	receiving device: absolute level	0,00
u_{j53}	EUT: influence of setting the power supply on the ERP of the carrier	
u_{j20}	position of the phase centre: within the EUT volume	
u_{j21}	positioning of the phase centre: within the EUT over the axis of rotation of the turntable	
u_{j50}	EUT: influence of the ambient temperature on the ERP of the carrier	
u_{j16}	range length	
u_{j01}	reflectivity of absorbing material: EUT to the test antenna	
u_{j45}	antenna: gain of the test antenna	0,00
u_{j46}	antenna: tuning of the test antenna	0,00
u_{j17}	correction: off boresight angle in the elevation plane	0,00
u_{j55}	EUT: mutual coupling to the power leads	
u_{j08}	mutual coupling: amplitude effect of the test antenna on the EUT	
u_{j04}	mutual coupling: EUT to its images in the absorbing materials	
u_{j13}	mutual coupling: EUT to its image in the ground plane	
u_{j06}	mutual coupling: test antenna to its images in the absorbing material	
u_{j14}	mutual coupling: test antenna to its image in the ground plane	
u_{j01}	random uncertainty (see note in clause A.18 of TR 102 273-1-2 and note in clause 6.4.7 of TR 102 273-1-1)	

The standard uncertainties from table 29 should be combined by RSS in accordance with clause 5 of TR 102 273-1-1 [8]. This gives the combined standard uncertainty (u_c contribution from the EUT measurement) for the EUT measurement in dB.

7.2.4.2 Uncertainty contributions: Stage 2: Substitution measurement

The second stage (the substitution) involves replacing the EUT with a substitution antenna and signal source as shown in figure 45 and adjusting the output level of the signal generator until the same level as in stage one is achieved on the receiving device.

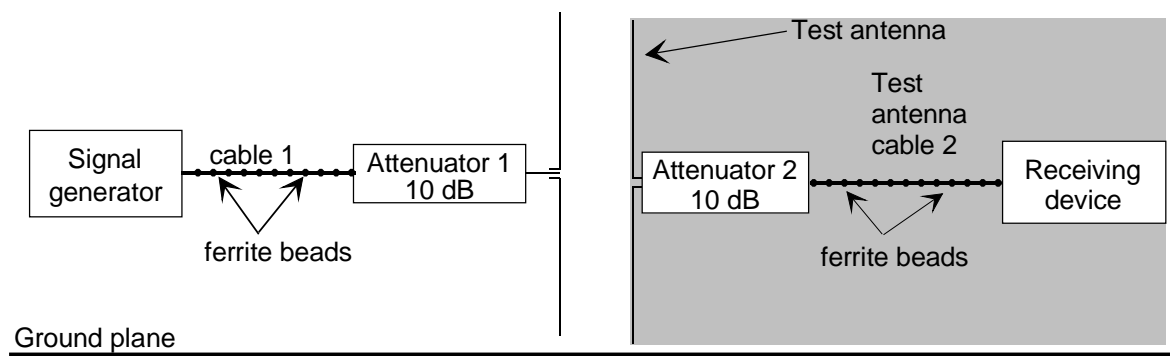

Figure 45: Stage 2: Substitution measurement

All the uncertainty components which contribute to this stage of the test are listed in table 30. Annex A should be consulted for the sources and/or magnitudes of the uncertainty contributions.

Table 30: Contributions from the substitution

u_j or i	Description of uncertainty contributions	DB
u_{j36}	mismatch: transmitting part	
u_{j37}	mismatch: receiving part	
u_{j38}	signal generator: absolute output level	
u_{j39}	signal generator: output level stability	
u_{j19}	cable factor: substitution antenna cable	
u_{j19}	cable factor: test antenna cable	
u_{j41}	insertion loss: substitution antenna cable	
u_{j41}	insertion loss: test antenna cable	0,00
u_{j40}	insertion loss: substitution antenna attenuator	
u_{j40}	insertion loss: test antenna attenuator	0,00
u_{j47}	receiving device: absolute level	0,00
u_{j16}	range length	0,00
u_{j18}	correction: measurement distance	
u_{j02}	reflectivity of absorbing material: substitution antenna to the test antenna	
u_{j45}	antenna: gain of substitution antenna	
u_{j45}	antenna: gain of the test antenna	0,00
u_{j46}	antenna: tuning of the substitution antenna	
u_{j46}	antenna: tuning of the test antenna	0,00
u_{j22}	position of the phase centre: substitution antenna	
u_{j17}	correction: off boresight angle in the elevation plane	
u_{j06}	mutual coupling: substitution antenna to its images in the absorbing material	
u_{j06}	mutual coupling: test antenna to its images in the absorbing material	
u_{j14}	mutual coupling: substitution antenna to its image in the ground plane	
u_{j14}	mutual coupling: test antenna to its image in the ground plane	
u_{j11}	mutual coupling: substitution antenna to the test antenna	
u_{j12}	mutual coupling: interpolation of mutual coupling and mismatch loss correction factors	
u_{j01}	random uncertainty (see note in clause A.18 of TR 102 273-1-2 and note in clause 6.4.7 of TR 102 273-1-1)	

The standard uncertainties from table 30 should be combined by RSS in accordance with clause 5 of TR 102 273-1-1 [8]. This gives the combined standard uncertainty (u_c contributions from the substitution) for the substitution measurement in dB.

7.2.4.3 Expanded uncertainty of the ERP measurement

The combined standard uncertainty of the effective radiated power measurement is the RSS combination of the components outlined in clauses 7.2.4.1 and 7.2.4.2. The components to be combined are u_c contribution from the EUT measurement and u_c contribution from the substitution:

$$u_c = \sqrt{u_{c\text{contribution from the EUT measurement}}^2 + u_{c\text{contribution from the substitution}}^2} = \text{---, --- dB} \quad (7.3)$$

The expanded uncertainty is $\pm 1,96 \times u_c = \pm \text{---, --- dB}$ at a 95 % confidence level.

7.2.5 Spurious emissions (30 MHz to 4 GHz or 12,75 GHz)

Spurious emissions are unwanted sources of radiation from an EUT. They are at frequencies other than those of the carrier and sidebands associated with normal modulation and by definition, their radiating mechanisms and locations within the equipment, as well as their directivities, polarizations and directions are unknown.

An EUT which is large in terms of wavelength, may possess highly directional (i.e. narrow beam) spurious, particularly at high frequencies, which could radiate at angles that are difficult to detect. Mainly for this reason, a "characterization" procedure, i.e. the identification of all frequencies at which an EUT radiates, should be performed in a shielded enclosure (i.e. an enclosure with metal walls but no absorbing material) prior to testing in the Anechoic Chamber with a Ground Plane. An additional benefit of the characterization procedure is that it ensures that no ambient is mistaken for a spurious emission in a poorly shielded chamber. Characterization should cover the full 30 MHz to 4 GHz or 12,75 GHz band (as stated in the relevant Standard).

Spurious emission testing is performed on all radio equipment possessing an integral antenna. For EUTs fitted with an external antenna connector, spurious emission testing is carried out with a broadband 50 Ω load (sometimes known as an artificial antenna) connected instead of the antenna. The test is then referred to as cabinet radiation testing.

NOTE: For integral antenna devices, the measurement of a spurious emission (for transmitters) is unavoidably performed in the presence of the carrier at full power level. Care should always be exercised under this condition to prevent overloading the input of the receiving device. For these receiving devices, for both characterization and spurious emission testing, a high "Q" notch filter (centred on the carrier frequency) should be used for frequencies up to approximately 1,5 times the carrier frequency and a high pass filter for frequencies above this (the cut-off being approximately 1,5 times the carrier frequency). This should be connected between the test antenna and the input to the receiving device as appropriate.

Definition

Spurious emissions are emissions at frequencies other than those of the carrier and sidebands associated with normal modulation.

The level of a spurious emission should be measured as either:

- the effective radiated power of the cabinet and integral antenna together, in the case of EUTs not fitted with an external antenna connector; or
- the effective radiated power of the cabinet and structure of the equipment combined (this is termed cabinet radiation) in the case of EUTs fitted with an external antenna connector.

7.2.5.1 Apparatus required

- digital voltmeter;
- ferrite beads;
- 10 dB attenuators;

- power supply;
- connecting cables;
- Anechoic Chamber with a Ground Plane;
- shielded chamber (Non-Anechoic);
- broadband test antenna (biconic, typically 30 MHz to 200 MHz, LPDAs, typically 200 MHz to 1 GHz and 1 GHz to 12,75 GHz or waveguide horns, typically 1 GHz to 12,75 GHz);
- substitution antenna (half wavelength dipole as detailed in ANSI C63.5 [1] recommended 30 MHz to 1 000 MHz and waveguide horns 1 GHz to 12,75 GHz);
- receiving device (measuring receiver or spectrum analyser);
- signal generator;
- high "Q" notch filter and high pass filter - only for tests on EUTs not fitted with a permanent antenna connector;
- 50 Ω load - only for tests on EUTs fitted with a permanent antenna connector. This load should perform well throughout the entire frequency band (typically VSWR 1,25:1 up to 1 000 MHz, better than 2,0:1 over 1 GHz to 4 GHz or 12,75 GHz). It should be able to absorb the maximum carrier power at the nominal frequency of the EUT.

The types and serial numbers of all items of test equipment should be recorded on page 1 of the log book results sheet (see table 32).

NOTE: The half wavelength dipole antennas, incorporating matching/transforming baluns, for the procedure are available in the following bands: 20 MHz to 65 MHz, 65 MHz to 180 MHz, 180 MHz to 400 MHz, 400 MHz to 1 000 MHz. Constructional details are contained in ANSI C63.5 [1]. In the recommended antenna scheme for this band, a shortened dipole is used at all frequencies from 30 MHz up to 80 MHz.

7.2.5.2 Method of measurement

Characterization

The process of characterization should take place within a shielded, totally reflecting enclosure where no absorbing material is present.

- C1) The EUT should be mounted on a non-conducting turntable of low relative dielectric constant (preferably less than 1,5) material(s) in a shielded enclosure (i.e. no absorber).
- C2) The test equipment should be arranged as shown in figure 46. The protecting filter should only be used for EUT which are not fitted with an external antenna connector. For those which do have such a connector, the broadband 50 Ω load should be connected to the EUT and the filter becomes unnecessary.
- C3) The EUT should be mounted in the position closest to its normal use as declared by the manufacturer. This mounting configuration should be recorded on page 1 of the log book results sheet (see table 32).

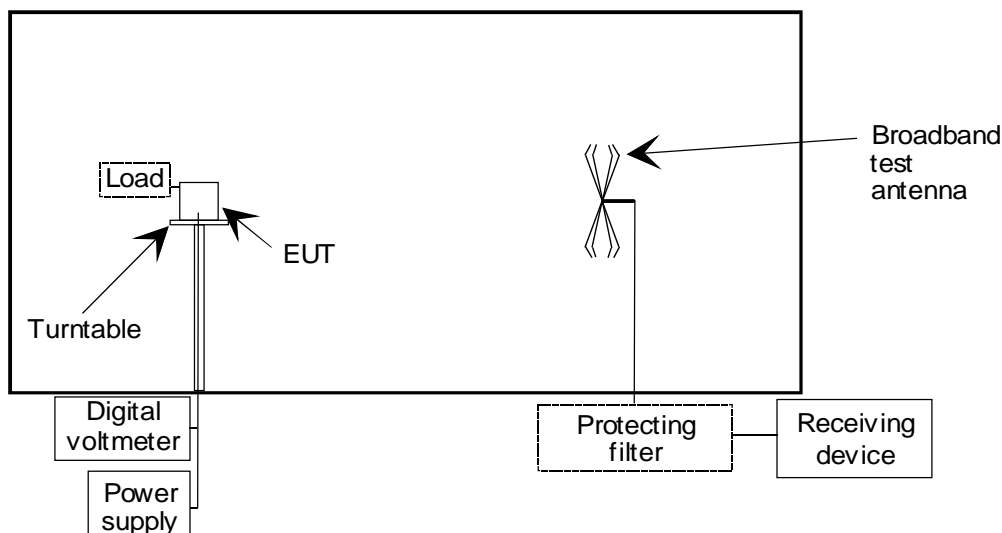

Figure 46: Elevation view of shielded chamber set up for the characterization tests

- C4) The broadband test antenna should be aligned for vertical polarization and spaced a convenient distance away from the EUT.

NOTE 1: For the purposes of this characterization procedure, the range length does not have to meet the conditions for far-field testing given earlier.

- C5) The EUT should be switched on, without modulation, and the receiving device scanned through the appropriate frequency band, avoiding the carrier frequency and its adjacent channels. All frequencies producing a response on the receiving device should be recorded on page 2 of the log book results sheet (see table 32).

NOTE 2: The test antenna should be changed as necessary to ensure that the complete frequency range is covered.

- C6) The broadband test antenna should be aligned for horizontal polarization and Step C5 repeated.

NOTE 3: The only information provided by the characterization procedure is which frequencies should be measured in the Anechoic Chamber with a Ground Plane.

Measurement

NOTE 4: The following procedure steps involve, for every frequency identified in the characterization procedure, scanning for the peak of the spurious emission in both horizontal and vertical planes around the EUT. The amplitude peak in both planes is measured in both horizontal and vertical polarizations. Large EUTs, however, may possess highly directional spurious emissions particularly at high frequencies and, despite the two plane scanning, there remains for these cases, a small possibility that no spurious can be detected.

- 1) The measurement should always be performed in the absence of modulation.
- 2) The EUT should be mounted directly onto the turntable whose surface is at a height (above the ground plane) specified in the relevant Standard. The items of test equipment should be set-up as shown in figure 47.

NOTE 5: The turntable should be constructed from non-conducting, low relative dielectric constant (preferably less than 1,5) material(s).

- 3) The EUT should be mounted in an orientation which matches that of its normal usage as declared by the manufacturer. The normal to the reference face of the EUT should point directly down the chamber towards the antenna mast. This is the 0° reference angle for this test. This orientation and mounting configuration should be recorded on page 1 of the log book results sheet (see table 32).
- 4) The volume centre of the EUT should be positioned on the turntable such that it lies on the axis of rotation of the turntable.
- 5) The height above the ground plane of the volume centre of the EUT should be recorded on page 2 of the log book results sheet (see table 32).

- 6) For EUTs fitted with a permanent antenna connector, the broadband 50Ω load should be connected in place of the antenna.
- 7) The test antenna (biconic, LPDA or waveguide horn) should be mounted on the antenna mast and oriented for vertical polarization. Its output should be connected to the receiving device via a 10 dB attenuator and the calibrated, ferrited coaxial cable associated with that end of the chamber, and a protective filter (only if the EUT does not possess an external antenna connector).
- 8) The EUT should be switched on, without modulation, and the receiving device tuned to the first frequency recorded on page 2 of the log book results sheet (see table 32).
- 9) The test antenna should be raised and lowered through the specified range of heights (1 m to 4 m, ensuring that no part of the antenna is less than 0,25 m from the ground plane at any time) until the maximum signal level is detected on the receiving device.

NOTE 6: The true maximum may lie beyond the top of the mast, in which case the maximum receivable level should be at the top of the height range.

- 10) The EUT should be rotated through 360° in the azimuth plane until the maximum signal level is observed on the receiving device. The corresponding received level (dBm_1), height of the test antenna on the mast (height_1) and angle of the turntable (angle_1) should be recorded on page 2 of the log book results sheet (see table 32).

Retaining the same height of the test antenna on the mast and angle of turntable, the power to the EUT should be turned off and the value of the level of the noise floor (amb_1) for the receiving device recorded on page 2 of the log book results sheet (see table 32).

- 11) The polarization of the test antenna should be changed to horizontal, the antenna height on the mast readjusted for maximum signal and the resulting received signal level (dBm_2) and the new height of the antenna on the mast (height_2) recorded on page 2 of the log book results sheet (see table 32). Again, by turning off the power to the EUT, a value for the level of the noise floor (amb_2) for the receiving device should be recorded on page 2 of the log book results (see table 32).

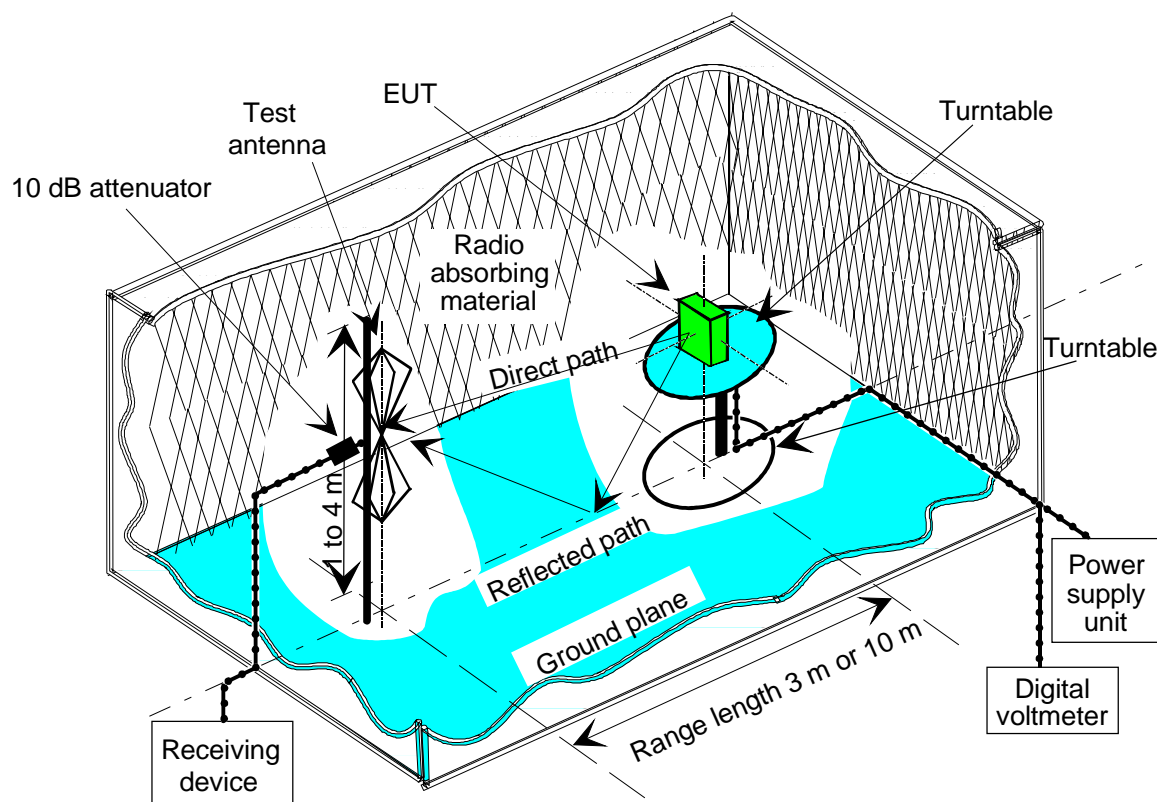

Figure 47: Anechoic Chamber with a Ground Plane set-up for Spurious emission testing on the EUT

- 12) Retaining the test antenna polarization (horizontal), the EUT should be rotated about its volume centre to lie on its side as shown in figure 48. The height of the test antenna on the mast should be adjusted for maximum received signal level. Using the turntable, the EUT should then be rotated through 360° in the azimuth plane to locate the angle of at which the maximum received signal level is again found. This maximum received level (dBm_3), the height of the test antenna on the mast (height_3) and the angle of the turntable (angle_2) should be recorded on page 2 of the log book results sheet (see table 32). Retaining the same height of the test antenna on the mast and angle of turntable, the power to the EUT should be turned off and the value of the level of the noise floor (amb_3) for the receiving device recorded on page 2 of the log book results sheet (see table 32).
- 13) The polarization of the test antenna should be changed to vertical, the antenna height on the mast readjusted for maximum signal and the resulting received signal level (dBm_4) and the new height of the antenna on the mast (height_4) recorded on page 2 of the log book results sheet (see table 32). Again, by turning off the power to the EUT, a value for the level of the noise floor (amb_4) for the receiving device should be recorded on page 2 of the log book results (see table 32).

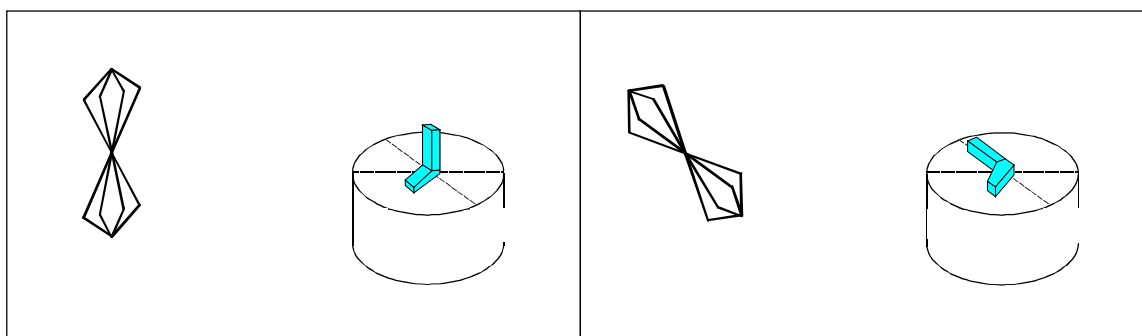

Figure 48: Turning the EUT

- 14) The EUT should be replaced on the turntable by the substitution antenna (a tuned half wavelength dipole which has been adjusted to correspond to the appropriate frequency or waveguide horn). See figure 49.

NOTE 7: For all frequencies below 80 MHz, a shortened dipole (as defined in clause 7.1.3) should be used. The dipole arm length is defined from the centre of the balun block to the tip of the arm. From a fully extended state, each telescopic element, in turn, should be "pushed in" from the tip until the required length is obtained. The outermost section needs to fully compress before any of the others, and so on. Table 22 gives the dipole arm lengths and choice of balun for set frequencies. Where the test frequency does not correspond to a set frequency in the table, the arm length to be used should be determined by linear interpolation between the closest set values.

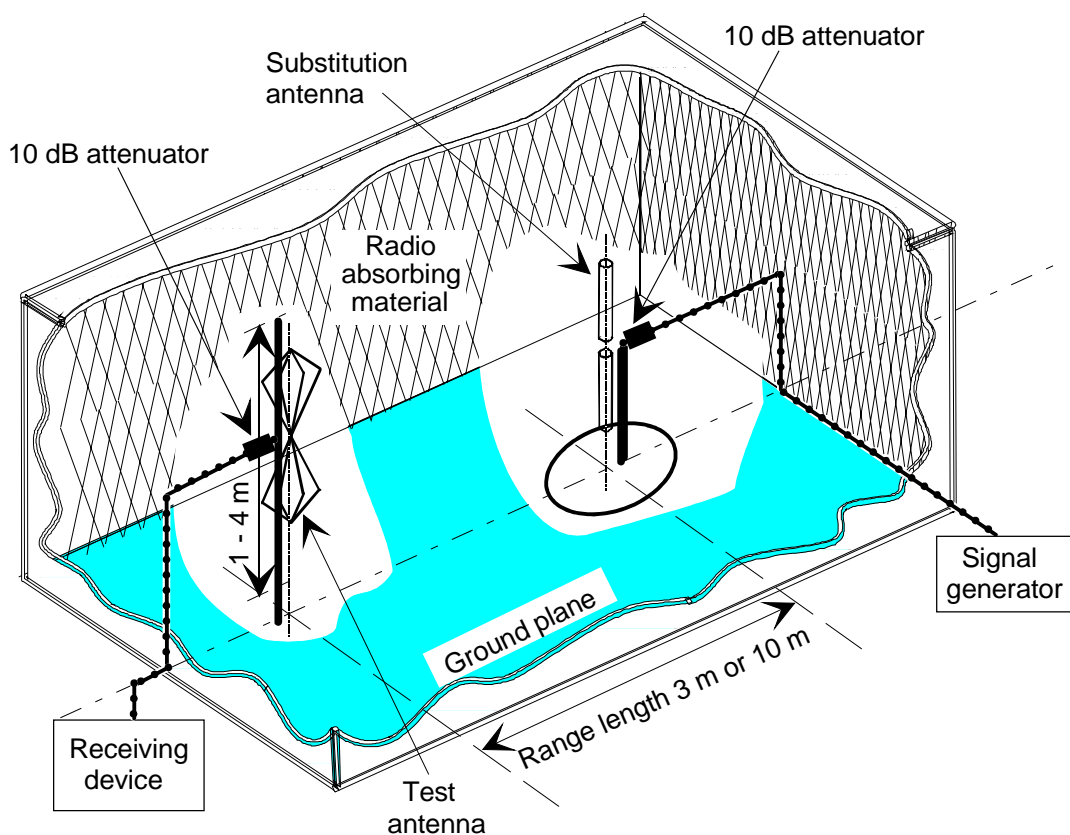

Figure 49: Substitution antenna replacing the EUT for Spurious emission testing in an Anechoic Chamber with a Ground Plane

15) The phase centre of the substitution antenna should be located at the same height above the floor as noted in Step 5 and should lie directly on the axis of rotation of the turntable.

NOTE 8: The phase centre of a dipole is in the centre of its two rods. That for a waveguide horn is in the centre of its open mouth.

16) The substitution antenna should be oriented for vertical polarization and connected to a calibrated signal generator via a 10 dB attenuator and the calibrated, ferrited, coaxial cable associated with that end of the chamber.

17) The signal generator should be tuned to the appropriate frequency and its output level adjusted until the level measured on the receiving device, is at least 20 dB above the level with the output from the signal generator switched off.

18) The test antenna should be raised and lowered through the specified range of heights until the maximum signal level is recorded on the receiving device. The height of the test antenna on the mast ($height_5$) should be recorded on page 2 of the log book results sheet (see table 32).

NOTE 9: The true maximum may lie beyond the top of the mast, in which case the maximum receivable level should be at the top of the height range.

19) The substitution antenna should be rotated until the maximum level is detected on the receiving device.

NOTE 10: This is to correct for possible misalignment of a directional beam (i.e. as produced by waveguide horns in all tests and by dipoles when used in horizontally polarized tests only). This step can be omitted for dipoles used in vertically polarized tests.

20) The output level of the signal generator should be adjusted until the level, measured on the receiving device, is the same as the larger of dBm_1 and dBm_4 . This output signal level (dBm_5) should be recorded on page 2 of the log book results sheet (see table 32).

NOTE 11: In the event of insufficient range of signal generator output level, the input attenuation to the receiving device should be decreased to compensate. The signal generator output level (dBm₅) and the change in attenuation (dB₁, where a decrease is taken as + dB, an increase is taken as - dB) should be recorded on page 2 of the log book results sheet (see table 32).

21) The test antenna and the substitution antenna should both be oriented for horizontal polarization and Steps 17 to 20 repeated. This time, height₆ is recorded in Step 18 and dBm₆ and dB₂ recorded in Step 20 after adjustment of the signal generator output level until the receiving device level is the larger of dBm₂ and dBm₃.

22) Steps 1 to 21 should be repeated for all the other frequencies recorded in the log book results sheet (see table 32) changing the antennas as necessary.

7.2.5.3 Procedure for completion of the results sheets

There are several values that remain to be entered in the overall results sheet (see table 33). These are the overall spurious emission levels (corrected for the systematic offsets involved in the measurement) and the expanded measurement uncertainty.

Initially, the overall correction factors for each of the two polarizations should be calculated. Then, all received signal levels (i.e. dBm₁ to dBm₄) should be corrected to convert them into effective radiated power figures, the corrections not only accounting for the systematic offsets (cable losses, attenuator loss, etc.) but also for the different measurement distances and off boresight elevation angles involved. All corrections should be made relating the measurement to the corresponding substitution measurement for that polarization.

Table 31 lists all the correction factors involved in this procedure along with giving guidance on how their values can be obtained. It should be noted that some values differ depending on the polarization considered.

Once derived, all the various correction factors should be incorporated into the following formula for overall correction for both polarizations:

$$\begin{aligned}
 \text{overall correction factor} &= \text{substitution antenna cable loss} \\
 &+ \text{substitution antenna attenuator loss} \\
 &+ \text{substitution antenna balun loss} \\
 &+ \text{mutual coupling and mismatch loss (where applicable)} \\
 &+ \text{correction for measurement distance} \\
 &+ \text{correction for off-boresight elevation angles} \\
 &- \text{gain of substitution antenna} \\
 &- \text{decrease in input attenuation to receiving device (if any)}
 \end{aligned}$$

NOTE: For frequencies greater than 180 MHz the mutual coupling and mismatch loss factor should be taken as 0,00 dB.

Both values of overall correction factor should be entered on page 2 of the log book results sheet (see table 32):

All four received signal levels (dBm₁ to dBm₄) should then be corrected by the relevant overall correction factor (i.e. dBm₁ and dBm₄ with the vertically polarized correction factor, dBm₂ and dBm₃ with the horizontally polarized one) to reveal effective radiated power levels (erp₁, erp₂, erp₃ and erp₄ respectively) in dBm. These four ERP values should be entered on page 2 of the log book results sheet (see table 32).

Table 31: Guidance for deriving correction factors

Figures for correction factors	
Substitution antenna cable loss	Obtained directly from the calibration data
Substitution antenna attenuator loss	Obtained from calibration data
Substitution antenna balun loss	For dipoles only, if not known from calibration this value should be taken as 0,3 dB. For waveguide horns the value is 0,00 dB
Mutual coupling mismatch loss correction factors between the test antenna and the substitution antenna	For ANSI dipoles (30 MHz to 180 MHz) can be obtained from TR 102 273-1-2 [9], table A.20. For frequencies greater than 180 MHz, this value is 0,00 dB. For non-ANSI dipoles this value is 0,00 dB
Measurement distance	(only for different heights of the test antenna). The correction is the difference between the values for the 2 heights in the 2 stages of the test. A value for each height should be taken from TR 102 273-1-2 [9] figure A.7. Value 1 (height for the measurement on the EUT)....dB Value 2 (height for the substitution measurement)....dB Correction value is: (value 2 - value 1) dB
Off boresight angle in elevation plane (for vertically polarized case only)	(only for different heights of the test antenna). The correction is the difference between the values for the 2 heights in the 2 stages of the test. A value for each height should be taken from TR 102 273-1-2 [9] figure A.8. Value 1 (height for the measurement on the EUT)....dB Value 2 (height for the substitution measurement)....dB Correction value is: (value 2 - value 1) dB
Gain of substitution antenna	2,10 dBi for ANSI dipoles (30 MHz to 1 000 MHz) for other types the value can be obtained from calibration data
NOTE: For horizontally polarized test this is 0,00 dB.	

The final calculation is to combine the two polarization components of the spurious in both planes in the following manner.

- If the calculated effective radiated power value erp_1 is more than 20 dB greater than erp_2 , then "Spurious level 1", is simply the value of erp_1 . Similarly, if erp_2 exceeds erp_1 by more than 20 dB, "Spurious level 1" is simply erp_2 . Alternatively, the spurious level should be calculated as:

$$Spuriouslevel\ 1 = 20\log\left(10^{\left(\frac{erp_1}{20}\right)} + 10^{\left(\frac{erp_2}{20}\right)}\right)\text{dBm} \quad (7.4)$$

- The resulting value should be entered on page 2 of the log book results sheet as "Spurious level 1".
- If the calculated ERP value erp_3 is more than 20 dB greater than erp_4 , then "Spurious level 2", is simply the value of erp_3 . Similarly, if erp_4 exceeds erp_3 by more than 20 dB, "Spurious level 2" is simply erp_4 . Alternatively, the spurious level should be calculated as:

$$Spuriouslevel\ 2 = 20\log\left(10^{\left(\frac{erp_3}{20}\right)} + 10^{\left(\frac{erp_4}{20}\right)}\right)\text{dBm} \quad (7.5)$$

- The resulting value should be entered on page 2 of the log book results sheet as "Spurious level 2".
- Whichever value is the larger of "Spurious level 1" and "Spurious level 2" should be entered as "Overall spurious level" on page 2 of the log book results sheet (see table 32). The resulting value is the ERP of the Spurious emission and should entered as such in the overall results table (see table 33).

The final value to be entered in the overall results sheet (see table 33) is that for the expanded uncertainty. This should be calculated according to clause 7.2.6.

7.2.5.4 Log book entries

Table 32: Log book results sheet

SPURIOUS EMISSIONS			Date:	PAGE 1 of 2		
Temperature:.....°C		Humidity:.....%		Frequency:.....MHz		
Manufacturer of EUT:.....		Type No:.....		Serial No:.....		
Bandwidth of Receiving Device.....Hz						
Range length:.....						
Test equipment item	Type No.	Serial No.	VSWR	Insertion loss	Antenna factor/gain	
Broadband test antenna (typically 30 MHz to 200 MHz)				N/A		
Broadband test antenna (typically 200 MHz to 1 GHz)				N/A		
Broadband test antenna (typically 1 GHz to 12,75 GHz)				N/A		
Test antenna attenuator					N/A	
Test antenna cable					N/A	
Substitution antenna (typically ANSI C63.5 [1] 30 MHz to 1 000 MHz)				N/A		
Substitution antenna (typically waveguide horns 1 GHz to 12,75 GHz)				N/A		
Substitution antenna attenuator					N/A	
Substitution antenna cable					N/A	
Digital voltmeter			N/A	N/A	N/A	
Power supply			N/A	N/A	N/A	
Receiving device				N/A	N/A	
Signal generator				N/A	N/A	
Ferrite beads			N/A	N/A	N/A	
High "Q" notch filter					N/A	
High pass filter					N/A	
Mounting configuration of EUT (Characterization)						
Mounting configuration of EUT (Measurement)						

SPURIOUS EMISSIONS				Date:		PAGE 1 of 2									
Temperature:.....°C		Humidity:.....%		Frequency:.....MHz											
Manufacturer of EUT:.....		Type No:.....		Serial No:.....											
Bandwidth of Receiving Device.....Hz															
Range length:.....															
Test equipment item		Type No.	Serial No.	VSWR	Insertion loss	Antenna factor/gain									
Height above the ground plane of the volume centre of the EUTm															
Frequency (MHz)															
dBm ₁															
Height ₁															
Angle ₁															
amb ₁															
dBm ₂															
Height ₂															
amb ₂															
dBm ₃															
Height ₃															
Angle ₂															
amb ₃															
dBm ₄															
Height ₄															
amb ₄															
Signal generator output level (dBm ₅)															
Change in attenuator level (dB ₁)															
Signal generator output level (dBm ₆)															
Change in attenuator level (dB ₂)															
Overall correction factor - Vertical polarization															
Overall correction factor - Horizontal polarization															
erp ₁															
erp ₂															
erp ₃															
erp ₄															
Spurious level 1															
Spurious level 2															
Overall Spurious level dBm															
Correction factors															
polarization															
Frequency (MHz)															
		V	H	V	H	V	H	V	H	V	H	V	H	V	H
Substitution antenna cable loss															
Substitution antenna attenuator loss															
Substitution antenna balun loss															
Mutual coupling and mismatch loss (30 MHz to 180 MHz)															
Measurement distance															
Off-elevation boresight level															
Gain of the substitution antenna															
Overall measurement correction		dB		dB		dB		dB		dB		dB		dB	

7.2.5.5 Statement of results

The results should be presented in tabular form as shown in table 33.

Table 33: Overall results sheet

SPURIOUS EMISSIONS			Date:	PAGE 1 of 1			
Frequency (MHz)							
Spurious emission ERP (dBm)							
Expanded uncertainty (95 %) (dB)							

7.2.6 Measurement uncertainty for Spurious emissions

A fully worked example illustrating the methodology to be used can be found in clause 4 of TR 102 273-1-2 [9].

7.2.6.1 Uncertainty contributions: Stage 1: EUT measurement

For the measurement of spurious effective radiated power two stages of test are involved. The first stage (the EUT measurement) is to measure on the receiving device, a level from the EUT as shown in figure 50 (shaded components are common to both stages of the test).

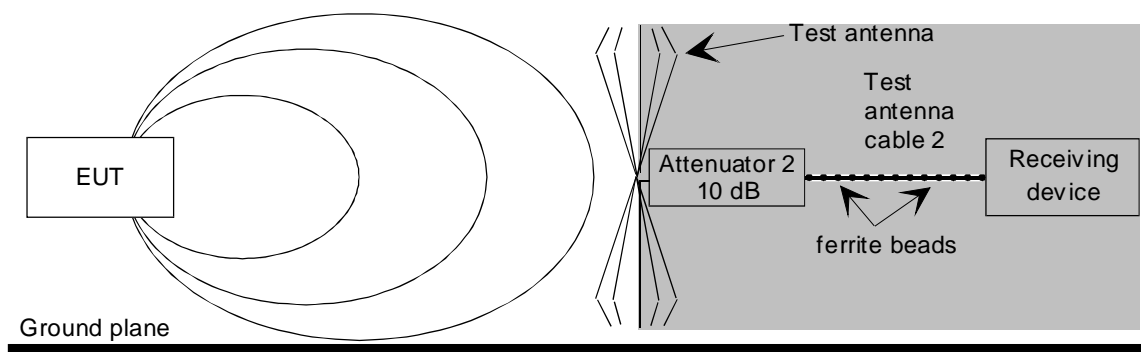

Figure 50: Stage 1: EUT measurement

Due to the commonality of all of the components from the test antenna to the receiver in both stages of the test, the mismatch uncertainty contributes identically to both stages and hence cancels. Similarly, the systematic uncertainty contributions (e.g. test antenna cable loss, etc.) of the individual components also cancel.

The magnitude of the random uncertainty contribution to this stage of the procedure can be assessed from multiple repetition of the EUT measurement.

All the uncertainty components which contribute to this stage of the test are listed in table 34. Annex A should be consulted for the sources and/or magnitudes of the uncertainty contributions.

Table 34: Contributions from the measurement on the EUT

$u_{j \text{ or } i}$	Description of uncertainty contributions	dB
u_{j37}	mismatch: receiving part	
u_{j19}	cable factor: test antenna cable	0,00
u_{j41}	insertion loss: test antenna cable	0,00
u_{j40}	insertion loss: test antenna attenuator	0,00
u_{j47}	receiving device: absolute level	0,00
u_{j54}	EUT: influence of setting the power supply on the spurious emission levels	
u_{j20}	position of the phase centre: within the EUT volume	
u_{j21}	positioning of the phase centre: within the EUT over the axis of rotation of the turntable	
u_{j51}	EUT: influence of the ambient temperature on the spurious emission level	
u_{j16}	range length	
u_{j18}	correction: measurement distance	
u_{j01}	reflectivity of absorbing material: EUT to the test antenna	
u_{j45}	antenna: gain of the test antenna	0,00
u_{j46}	antenna: tuning of the test antenna	0,00
u_{j55}	EUT: mutual coupling to the power leads	
u_{j08}	mutual coupling: amplitude effect of the test antenna on the EUT	
u_{j04}	mutual coupling: EUT to its images in the absorbing materials	
u_{j13}	mutual coupling: EUT to its image in the ground plane	
u_{j06}	mutual coupling: test antenna to its images in the absorbing material	
u_{j14}	mutual coupling: test antenna to its image in the ground plane	
u_{j01}	random uncertainty (see note in clause A.18 of TR 102 273-1-2 and note in clause 6.4.7 of TR 102 273-1-1)	

The standard uncertainties from table 34 should be combined by RSS in accordance with clause 5 of TR 102 273-1-1 [8]. This gives the combined standard uncertainty (u_c contribution from the EUT measurement) for the EUT measurement in dB.

7.2.6.2 Uncertainty contributions: Stage 2: Substitution measurement

The second stage (the substitution) involves replacing the EUT with a substitution antenna and signal source as shown in figure 51 and adjusting the output level of the signal generator until the same level as in stage one is achieved on the receiving device.

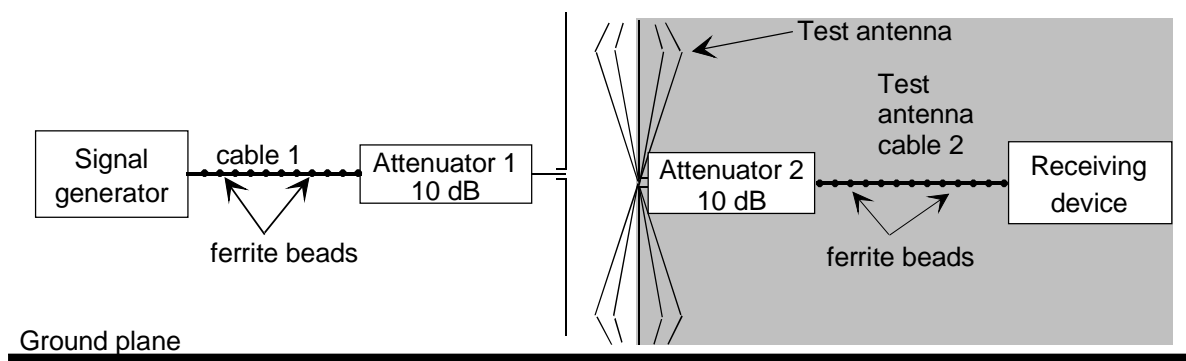

Figure 51: Stage 2: Substitution measurement

All the uncertainty components which contribute to this stage of the test are listed in table 35. Annex A should be consulted for the sources and/or magnitudes of the uncertainty contributions.

Table 35: Contributions from the substitution

$u_{j \text{ or } i}$	Description of uncertainty contributions	dB
u_{j36}	mismatch: transmitting part	
u_{j37}	mismatch: receiving part	
u_{j38}	signal generator: absolute output level	
u_{j39}	signal generator: output level stability	
u_{j19}	cable factor: substitution antenna cable	
u_{j19}	cable factor: test antenna cable	
u_{j41}	insertion loss: substitution antenna cable	
u_{j41}	insertion loss: test antenna cable	0,00
u_{j40}	insertion loss: substitution antenna attenuator	
u_{j40}	insertion loss: test antenna attenuator	0,00
u_{j47}	receiving device: absolute level	0,00
u_{j16}	range length	0,00
u_{j18}	correction: measurement distance	
u_{j02}	reflectivity of absorbing material: substitution antenna to the test antenna	
u_{j45}	antenna: gain of substitution antenna	
u_{j45}	antenna: gain of the test antenna	0,00
u_{j46}	antenna: tuning of the substitution antenna	
u_{j46}	antenna: tuning of the test antenna	0,00
u_{j22}	position of the phase centre: substitution antenna	
u_{j17}	correction: off boresight angle in the elevation plane	
u_{j06}	mutual coupling: substitution antenna to its images in the absorbing material	
u_{j06}	mutual coupling: test antenna to its images in the absorbing material	
u_{j14}	mutual coupling: substitution antenna to its image in the ground plane	
u_{j14}	mutual coupling: test antenna to its image in the ground plane	
u_{j11}	mutual coupling: substitution antenna to the test antenna	
u_{j12}	mutual coupling: interpolation of mutual coupling and mismatch loss correction factors	
u_{j01}	random uncertainty (see note in clause A.18 of TR 102 273-1-2 and note in clause 6.4.7 of TR 102 273-1-1)	

The standard uncertainties from table 35 should be combined by RSS in accordance with clause 5 of TR 102 273-1-1 [8]. This gives the combined standard uncertainty (u_c contribution from the substitution) for the EUT measurement in dB.

7.2.6.3 Expanded uncertainty of the Spurious emission

The combined standard uncertainty of the ERP measurement of the spurious emission is the combination of the components outlined in clauses 7.2.6.1 and 7.2.6.2. The components to be combined are u_c contribution from the EUT measurement and u_c contribution from the substitution:

$$u_c = \sqrt{u_{c \text{ contribution from the EUT measurement}}^2 + u_{c \text{ contribution from the substitution}}^2} = _, _ \text{ dB} \quad (7.6)$$

The expanded uncertainty is $\pm 1,96 * u_c = \pm _, _ \text{ dB}$ at a 95 % confidence level.

7.2.7 Adjacent channel power

This test is normally carried out using a Test Fixture and as a result has not been considered for this facility.

7.3 Receiver tests

The tests carried out on receivers can be divided into two categories, namely sensitivity and immunity. However, only sensitivity tests are considered here.

7.3.1 Sensitivity tests (30 MHz to 1 000 MHz)

The test method for measuring the maximum or average usable sensitivity of a receiver is in two parts. In the first part, a transform factor for the test site (i.e. the relationship in decibels between the output power level (in dBm) from the signal generator to the resulting electric field strength (in dB μ V/m) at the point of test) is determined. In the second part, the sensitivity of the EUT is measured by finding the lowest output level from the signal generator which produces the required response at each of eight angles in the horizontal plane.

The receiver output depends on the type of information the receiver has been designed to demodulate. There are principally three different types of information: analogue speech, bit stream and messages.

Definition

For analogue speech:

- the **maximum usable sensitivity** expressed as field strength is the minimum of eight field strength (in dB μ V/m) measurements (at 45° increments in the horizontal plane) at the nominal frequency of the receiver and with specified test modulation, which produces a SINAD ratio of 20 dB measured at the receiver input through a telephone psophometric weighting network. The starting horizontal angle is the reference orientation as stated by the manufacturer.
- the **average usable sensitivity** expressed as field strength is the average of eight field strength (in dB μ V/m) measurements (at 45° increments in the horizontal plane) at the nominal frequency of the receiver and with specified test modulation, which produces a SINAD ratio of 20 dB measured at the receiver input through a telephone psophometric weighting network. The starting horizontal angle is the reference orientation as stated by the manufacturer.

For bit stream:

- the **maximum usable sensitivity** expressed as field strength is the minimum of eight field strength (in dB μ V/m) measurements (at 45° increments in the horizontal plane) at the nominal frequency of the receiver and with specified test modulation, which produces, after demodulation, a data signal with a bit error ratio of 10^{-2} measured at the receiver input. The starting horizontal angle is the reference orientation as stated by the manufacturer.
- the **average usable sensitivity** expressed as field strength is the average of eight field strength (in dB μ V/m) measurements (at 45° increments in the horizontal plane) at the nominal frequency of the receiver and with specified test modulation, which produces, after demodulation, a data signal with a bit error ratio of 10^{-2} measured at the receiver input. The starting horizontal angle is the reference orientation as stated by the manufacturer.

For messages:

- the **maximum usable sensitivity** expressed as field strength is the minimum of eight field strength (in dB μ V/m) measurements (at 45° increments in the horizontal plane) at the nominal frequency of the receiver, and with specified test modulation, which produces, after demodulation, a message acceptance ratio of 80 % measured at the receiver input. The starting horizontal angle is the reference orientation as stated by the manufacturer.
- the **average usable sensitivity** expressed as field strength is the average of 8 field strength (in dB μ V/m) measurements (at 45° increments in the horizontal plane) at the nominal frequency of the receiver and with specified test modulation, which produces, after demodulation, a message acceptance ratio of 80 % measured at the receiver input. The starting horizontal angle is the reference orientation as stated by the manufacturer.

7.3.1.1 Apparatus required

- digital voltmeter;
- ferrite beads;
- 10 dB attenuators;
- power supply;
- connecting cables;
- Anechoic Chamber with a Ground Plane;
- test antenna (half wavelength dipole as detailed in ANSI C63.5 [1] recommended);
- measuring antenna (half wavelength dipole as detailed in ANSI C63.5 [1] recommended);
- RF signal generator;
- receiving device (measuring receiver or spectrum analyser).

Additional requirements for analogue speech:

- AF source;
- SINAD Metre (incorporating telephone psophometric weighting network);
- acoustic coupler (alternatively: audio load).

Additional requirements for bit stream:

- bit stream generator;
- bit error measuring test set.

Additional requirements for messages:

- acoustic coupler;
- message generator;
- response measuring test set.

The types and serial numbers of all items of test equipment should be recorded on page 1 of the log book results sheet (see table 37).

NOTE: The half wavelength dipole antennas, incorporating matching/transforming baluns, for the procedure are available in the following bands: 20 MHz to 65 MHz, 65 MHz to 180 MHz, 180 MHz to 400 MHz, 400 MHz to 1 000 MHz. Constructional details are contained in ANSI C63.5 [1]. In the recommended antenna scheme for this band, a shortened dipole is used at all frequencies from 30 MHz up to 80 MHz.

7.3.1.2 Method of measurement

Determination of the transform factor for the test site

- 1) For this part of the test, it is necessary to position the measuring antenna such that its phase centre is at the same height above the ground plane as the phase centre of the EUT in the second part of the test. The height of the phase centre of the EUT should be either measured remotely or determined by sitting the EUT on the turntable. The height above the turntable (whose mounting surface should be at the height above the ground plane as specified in the relevant Standard) should be recorded on page 2 of the log book results sheet (see table 37).

NOTE 1: If the position of the phase centre within the EUT is unknown but the antenna is visible, then the height above the ground plane of the point at which the antenna meets the case of the EUT should be used. If the phase centre is unknown and there is no visible antenna, the volume centre of the EUT should be used instead.

- 2) The measuring antenna (in the recommended scheme: a tuned ANSI C63.5 [1] half wavelength dipole for frequencies of 80 MHz and above, a shortened dipole for frequencies from 30 MHz up to 80 MHz) should be adjusted to correspond to the nominal frequency of the EUT and positioned with its phase centre on the axis of rotation of the turntable and at the height above it as recorded in Step 1. It should be oriented for vertical polarization.

NOTE 2: For all frequencies below 80 MHz, a shortened dipole (as defined in clause 7.1.3) should be used. The dipole arm length is defined from the centre of the balun block to the tip of the arm. From a fully extended state, each telescopic element, in turn, should be "pushed in" from the tip until the required length is obtained. The outermost section needs to fully compress before any of the others, and so on. Table 22 gives the dipole arm lengths and choice of balun for set frequencies. Where the test frequency does not correspond to a set frequency in the table, the arm length to be used should be determined by linear interpolation between the closest set values.

NOTE 3: The turntable should be constructed from non-conducting, low relative dielectric constant (preferably less than 1,5) material(s).

- 3) The measuring antenna should be connected via a 10 dB attenuator and the calibrated, ferrited coaxial cable associated with that end of the chamber, to the receiving device.
- 4) The test antenna (identical to the measuring antenna) should be mounted on the antenna mast, tuned to the nominal frequency of the EUT and oriented for vertical polarization.
- 5) The test antenna should be connected via a 10 dB attenuator and the calibrated, ferrited coaxial cable associated with that end of the chamber, to the signal generator whose output is unmodulated. See figure 52. The signal generator should be tuned to the nominal frequency of the EUT.

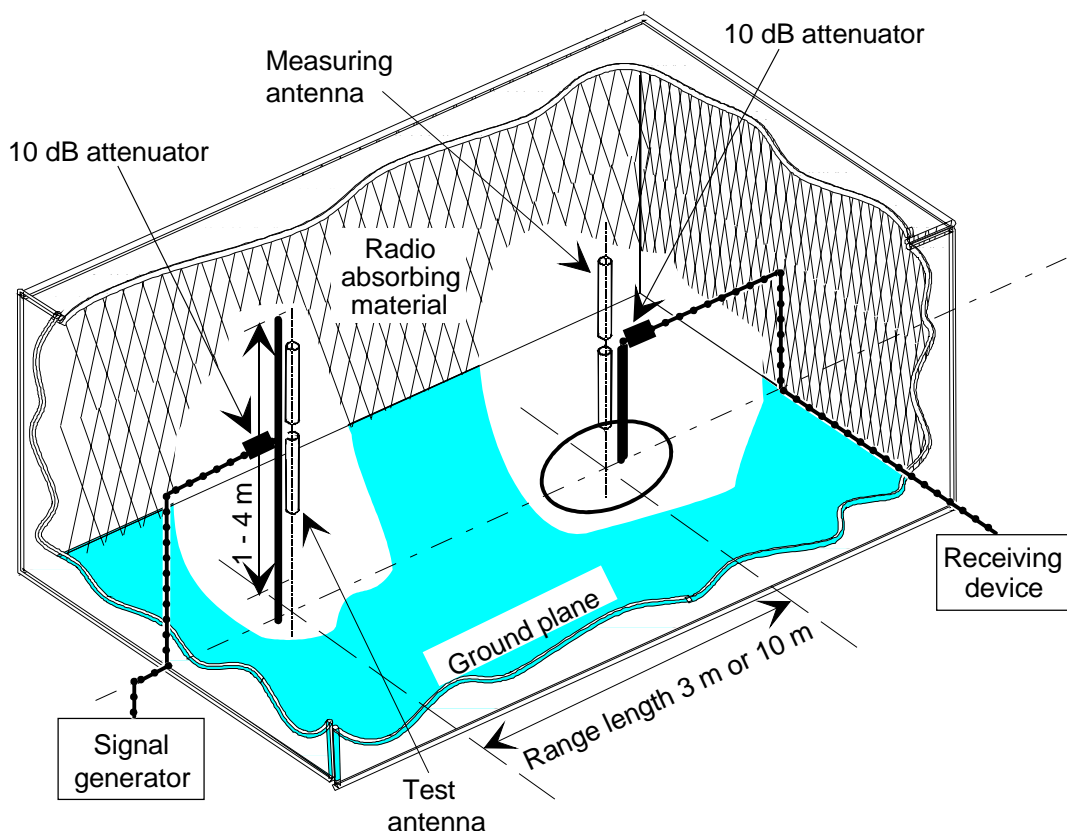

Figure 52: Equipment layout for the derivation of the transform factor during Sensitivity tests in an Anechoic Chamber with a Ground Plane

- 6) The output level of the signal generator should be adjusted until a received signal level at least 20 dB above the noise floor is observed on the receiving device.

- 7) The test antenna should be raised and lowered through the specified range of heights whilst monitoring the received signal level on the receiving device. The test antenna should be positioned at the height corresponding to the maximum received signal. This height should be recorded on page 2 of the log book results sheet (see table 37).

NOTE 4: The true maximum may lie beyond the top of the mast, in which case the maximum receivable level should be at the top of the height range.

- 8) The measuring antenna should be rotated in the horizontal plane until the maximum level is detected on the receiving device.

NOTE 5: This is to correct for possible misalignment of a directional beam i.e. dipoles used in horizontally polarized tests. This step can be omitted when dipoles are used in vertically polarized tests.

- 9) The maximum received signal level (dB μ V) appearing on the receiving device along with the output level from the signal generator (dBm) should be recorded on page 2 of the log book results sheet (see table 37). The transform factor for the chamber (i.e. the factor relating the output power level from the signal generator (dBm) to the resulting field strength (dB μ V/m) at the point of measurement) should be calculated according to the following formula:

$$\begin{aligned} \text{transform factor} &= \text{maximum received signal level (dB}\mu\text{V)} \\ &+ \text{measuring antenna cable loss} \\ &+ \text{measuring antenna attenuator loss} \\ &+ \text{measuring antenna balun loss} \\ &+ \text{mutual coupling and mismatch loss correction factor (if applicable)} \\ &+ \text{antenna factor of the measuring antenna} \\ &- \text{signal generator output level (dBm)} \end{aligned}$$

NOTE 6: Guidance for deriving/calculating/finding the unknown values in the above formula for transform factor are given in table 36. These values should be entered on page 2 of the log book results sheet (see table 37).

The resulting value for the transform factor should be entered on page 2 of the log book results sheet (see table 37).

Table 36: Guidance for deriving transform factor

Values in the formula for transform factor	
Measuring antenna cable loss	Obtained directly from the calibration data
Measuring antenna attenuator loss	Obtained directly from the calibration data
Measuring antenna balun loss	If not known from calibration data, the value should be taken as 0,30 dB
Mutual coupling and mismatch loss correction factors between the test antenna and the measuring antenna	For ANSI dipoles (30 MHz to 180 MHz), values can be obtained from TR 102 273-1-2 [9] table A20. For frequencies greater than 180 MHz, this value is 0,00 dB. For non-ANSI dipoles this value is 0,00 dB
Antenna factor of the measuring antenna	For ANSI dipoles: Antenna factor = $20 \log_{10}(f) - 31,4$ dB/m (where f is the frequency in MHz). For other types the value can be obtained from calibration data

Sensitivity measurement on the EUT

- 10) The measuring antenna should be replaced on the turntable by the EUT. The EUT should be positioned on the turntable such that its phase centre is in the same place as formerly occupied by the phase centre of the measuring antenna.

NOTE 7: If the position of the phase centre within the EUT is unknown but the antenna is a single rod which is visible and vertical in normal usage, the axis of the antenna should be aligned with the axis of rotation of the turntable. If the phase centre is not known and there is no visible antenna the volume centre of the EUT should be aligned with the axis of rotation of the turntable.

11) The EUT should be mounted in an orientation which matches that of its normal usage as declared by the manufacturer. The normal to its reference face should point directly towards the antenna mast. This is the 0° reference angle for this test. This orientation and mounting configuration should be recorded on page 1 of the log book results sheet (see table 37).

For analogue speech:

12a) The EUT should be connected to the modulation detector (a SINAD metre incorporating a telephone psophometric weighting network) through an AF load (see figure 53) or by an acoustic coupler which is made from low dielectric constant (i.e. less than 1,5) material(s) for EUTs not fitted with a direct connection.

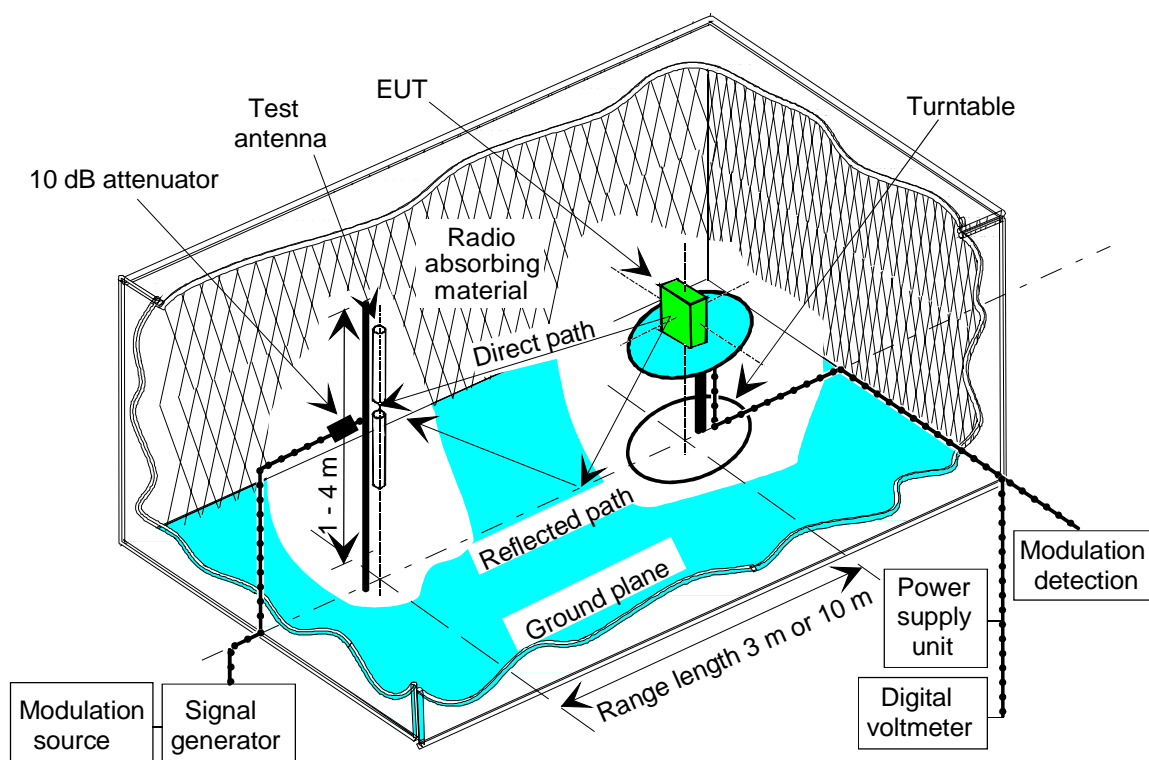

Figure 53: Anechoic Chamber with a Ground Plane set-up for Sensitivity tests on the EUT

- 12b) The signal generator output should be modulated with test modulation AM-1 (produced by the AF source) and its output level should be adjusted until a psophometrically weighted SINAD ratio of 20 dB is obtained from the EUT. The corresponding signal generator output power level should be recorded on page 2 of the log book results sheet (see table 37).
- 12c) The EUT should be successively rotated through 45° in the horizontal plane to new testing angles of 45°, 90°, 135°, 180°, 225°, 270°, 315° (thereby covering the entire 360° in eight measurements). At each angle Step 12b should be repeated.
- 12d) The eight values of signal generator output power level resulting from Steps 12b and 12c should be converted into field strength values by firstly adding the transform factor to produce the field strength in dBμV/m and then secondly converting dBμV/m to μV/m i.e.:
- 1) field strength (dBμV/m) = signal generator level (dBm) + transform factor (dB);
 - 2) field strength (μV/m) = $10^{(\text{field strength (dB}\mu\text{V/m)}/20)}$.

The resulting values in μV/m should be entered on page 2 of the log book results sheet (see table 37).

For bit stream:

- 12a) The EUT should be connected to the modulation detector (a bit error measuring test set, which should also receive a direct input from the bit stream generator) by a direct connection. See figure 53.
- 12b) The signal generator output should be modulated with test modulation DM-2 (produced by the bit stream generator) and its output level should be adjusted until a bit error ratio of 10^{-2} is obtained from the EUT. The corresponding signal generator output power level should be recorded on page 2 of the log book results sheet (see table 37).
- 12c) The EUT should be successively rotated through 45° in the horizontal plane to new testing angles of 45° , 90° , 135° , 180° , 225° , 270° , 315° (thereby covering the entire 360° in eight measurements). At each angle Step 12b should be repeated.
- 12d) The eight values of signal generator output power level resulting from Steps 12b and 12c should be converted into field strength values by firstly adding the transform factor to produce the field strength in $\text{dB}\mu\text{V}/\text{m}$ and then secondly converting $\text{dB}\mu\text{V}/\text{m}$ to $\mu\text{V}/\text{m}$ i.e.:

1) field strength ($\text{dB}\mu\text{V}/\text{m}$) = signal generator level (dBm) + transform factor (dB);

2) field strength ($\mu\text{V}/\text{m}$) = $10^{(\text{field strength}(\text{dB}\mu\text{V}/\text{m})/20)}$.

The resulting values in $\mu\text{V}/\text{m}$ should be entered on page 2 of the log book results sheet (see table 37).

- 12e) The test procedure should now continue with Step 13.

For messages:

- 12a) The EUT should be connected to the modulation detector (a response measuring test set) via an acoustic coupler (pipe) which is made from low dielectric constant (i.e. less than 1,5) material(s) (see figure 53).
- 12b) The signal generator output should be modulated with test modulation DM-3 (produced by the message generator) and its output level should be adjusted until a message acceptance ratio of less than 10 % is obtained from the EUT.
- 12c) The test message should be transmitted repeatedly from the test antenna, whilst observing for each message whether a successful response is obtained. The output level of the signal generator should be increased by 2 dB for each occasion that a successful response is NOT obtained.
- 12d) Step 12c should be repeated until three consecutive successful responses are observed at the same output level from the signal generator. The output level from the signal generator should be recorded on page 2 of the log book results sheet (see table 37).
- 12e) The output signal level from the signal generator should be reduced by 1 dB. The new signal level should be recorded on page 2 of the log book results sheet (see table 37) and the response of the EUT observed.
- 12f) If a successful response is NOT obtained, the output signal level should be increased by 1 dB and the new level recorded in the results sheet. If a successful response IS obtained, the input level should not be changed until three consecutive successful responses have been observed. In this case, the output signal level from the signal generator should be reduced by 1 dB and the new level recorded in the results sheet. No signal levels should be recorded unless preceded by a change of level.
- 12g) Step 12f should be repeated until a total of 10 recorded values for the signal generator output level have been entered on page 2 of the log book results sheet (see table 37).
- 12h) The EUT should be successively rotated through 45° in the horizontal plane to new testing angles of 45° , 90° , 135° , 180° , 225° , 270° , 315° (thereby covering the entire 360° in 8 measurements). At each angle Steps 12b to 12g should be repeated.

12i) For each angle, the 10 recorded values of the signal generator output level (dBm) should be converted to field strength ($\mu\text{V/m}$) by firstly adding the transform factor to produce the field strength in $\text{dB}\mu\text{V/m}$ and then secondly converting $\text{dB}\mu\text{V/m}$ to $\mu\text{V/m}$ i.e.:

1) field strength ($\text{dB}\mu\text{V/m}$) = signal generator level (dBm) + transform factor (dB);

2) field strength ($\mu\text{V/m}$) = $10^{(\text{field strength}(\text{dB}\mu\text{V/m})/20)}$.

The resulting values in $\mu\text{V/m}$ should be entered on page 2 of the log book results sheet (see table 37).

12j) For each angle, the 10 new recorded values of field strength in $\mu\text{V/m}$ should be averaged according to the following formula:

$$\text{Average field strength } (\mu\text{V/m}) = \sqrt{\left(\frac{10}{\sum_{i=1}^{10} \frac{1}{\text{field strength } (\mu\text{V/m})_i^2}} \right)} \quad (7.7)$$

The resulting 8 average values should also be entered on page 2 of the log book results sheet (see table 37).

12k) The procedure should continue with Step 13.

13) For the maximum sensitivity test only, the lowest of the eight values of field strength ($\mu\text{V/m}$) calculated during the multiple-stage Step 12 represents the minimum field strength to which the EUT responds. This minimum value of field strength ($\mu\text{V/m}$) should be entered on page 2 of the log book results sheet (see table 37) as the maximum sensitivity.

14) For the average sensitivity test only, the average of the eight values of field strength ($\mu\text{V/m}$) calculated during the multiple-stage Step 12 represents the average field strength to which the EUT responds. This average value of field strength in $\mu\text{V/m}$ should now be calculated by the following:

$$\text{Average field strength } (\mu\text{V/m}) = \sqrt{\left(\frac{8}{\sum_{i=1}^8 \frac{1}{\text{field strength } (\mu\text{V/m})_i^2}} \right)} \quad (7.8)$$

This average value of field strength ($\mu\text{V/m}$) should be entered on page 2 of the log book results sheet (see table 37) as the average sensitivity.

15) Steps 3 to 14 should be repeated with both the test and measuring antennas oriented for horizontal polarization.

7.3.1.3 Procedure for completion of the overall results sheet

All the necessary processing of the measured results is carried out during the course of the test procedure. The only calculation that remains to be performed before the overall results sheet (see table 38) can be completed is the determination of the expanded uncertainty of the measurement. This should be performed as given in clause 7.3.2 and the resulting value entered in the overall results sheet (see table 38).

7.3.1.4 Log book entries

Table 37: Log book results sheet

RECEIVER SENSITIVITY			Date:	PAGE 1 of 2		
Temperature:.....°C		Humidity:.....%		Frequency:.....MHz		
Manufacturer of EUT:.....		Type No:.....		Serial No:.....		
Range length:.....						
Test equipment item	Type No.	Serial No.	VSWR	Insertion loss	Antenna factor	
Test antenna				N/A		
Test antenna attenuator					N/A	
Test antenna cable					N/A	
Measuring antenna				N/A		
Measuring antenna attenuator					N/A	
Measuring antenna cable					N/A	
Ferrite beads			N/A	N/A	N/A	
Receiving device				N/A	N/A	
Signal generator				N/A	N/A	
Digital voltmeter			N/A	N/A	N/A	
Power supply			N/A	N/A	N/A	
AF source (if applicable)			N/A	N/A	N/A	
SINAD metre (if applicable)			N/A	N/A	N/A	
Audio load (if applicable)			N/A	N/A	N/A	
Bit stream generator (if applicable)			N/A	N/A	N/A	
Bit error measuring test set (if applicable)			N/A	N/A	N/A	
Acoustic coupler (if applicable)			N/A	N/A	N/A	
Message generator (if applicable)			N/A	N/A	N/A	
Response measuring test set (if applicable)			N/A	N/A	N/A	
Mounting configuration of EUT						

(continued)

Table 37 (concluded): Log book results sheet

RECEIVER SENSITIVITY (analogue speech)									Date:	PAGE 2 of 2								
Vertical polarization									Horizontal polarization									
Height above the turntable			m						Height above the turntable			m						
Height of the test antenna			m						Height of the test antenna			m						
Received signal level			dB μ V						Received signal level			dB μ V						
Output level from signal generator			dBm						Output level from signal generator			dBm						
Transform factor			dB						Transform factor			dB						
Signal generator level (dBm) against angle for 20 dB SINAD									Signal generator level (dBm) against angle for 20 dB SINAD									
	0°	45°	90°	135°	180°	225°	270°	325°		0°	45°	90°	135°	180°	225°	270°	325°	
level									level									
Conversion to μ V/m									Conversion to μ V/m									
	0°	45°	90°	135°	180°	225°	270°	325°		0°	45°	90°	135°	180°	225°	270°	325°	
level									level									
MAXIMUM Sensitivity			μ V/m						MAXIMUM Sensitivity			μ V/m						
AVERAGE Sensitivity			μ V/m						AVERAGE Sensitivity			μ V/m						
Values in the formula for Transform factor																		
Measuring antenna cable loss									Measuring antenna cable loss									
Measuring antenna attenuator loss									Measuring antenna attenuator loss									
Measuring antenna balun loss									Measuring antenna balun loss									
Mutual coupling and mismatch loss (30 MHz to 180 MHz)									Mutual coupling and mismatch loss (30 MHz to 180 MHz)									
Antenna factor of the measuring antenna									Antenna factor of the measuring antenna									

RECEIVER SENSITIVITY (bit stream)									Date:	PAGE 2 of 2								
Vertical polarization									Horizontal polarization									
Height above the turntable			m						Height above the turntable			m						
Height of the test antenna			m						Height of the test antenna			m						
Received signal level			dB μ V						Received signal level			dB μ V						
Output level from signal generator			dBm						Output level from signal generator			dBm						
Transform factor			dB						Transform factor			dB						
Signal generator level (dBm) against angle for 10 ⁻² BER									Signal generator level (dBm) against angle for 10 ⁻² BER									
	0°	45°	90°	135°	180°	225°	270°	325°		0°	45°	90°	135°	180°	225°	270°	325°	
level									level									
Conversion to μ V/m									Conversion to μ V/m									
	0°	45°	90°	135°	180°	225°	270°	325°		0°	45°	90°	135°	180°	225°	270°	325°	
level									level									
MAXIMUM Sensitivity			μ V/m						MAXIMUM Sensitivity			μ V/m						
AVERAGE Sensitivity			μ V/m						AVERAGE Sensitivity			μ V/m						
Values in the formula for transform factor																		
Measuring antenna cable loss									Measuring antenna cable loss									
Measuring antenna attenuator loss									Measuring antenna attenuator loss									
Measuring antenna balun loss									Measuring antenna balun loss									
Mutual coupling and mismatch loss (30 MHz to 180 MHz)									Mutual coupling and mismatch loss (30 MHz to 180 MHz)									
Antenna factor of the measuring antenna									Antenna factor of the measuring antenna									

RECEIVER SENSITIVITY (messages)									Date:	PAGE 2 of 2							
Vertical polarization									Horizontal polarization								
Height above the turntable				m					Height above the turntable				m				
Height of the test antenna				m					Height of the test antenna				m				
Received signal level				dB μ V					Received signal level				dB μ V				
Output level from signal generator				dBm					Output level from signal generator				dBm				
Transform factor				dB					Transform factor				dB				
Signal generator level (dBm) against angle									Signal generator level (dBm) against angle								
level	0°	45°	90°	135°	180°	225°	270°	325°	level	0°	45°	90°	135°	180°	225°	270°	325°
1									1								
2									2								
3									3								
4									4								
5									5								
6									6								
7									7								
8									8								
9									9								
10									10								
Conversion to μ V/m									Conversion to μ V/m								
level	0°	45°	90°	135°	180°	225°	270°	325°	level	0°	45°	90°	135°	180°	225°	270°	325°
1									1								
2									2								
3									3								
4									4								
5									5								
6									6								
7									7								
8									8								
9									9								
10									10								
Ave.									Ave.								
MAXIMUM Sensitivity				μ V/m					MAXIMUM Sensitivity				μ V/m				
AVERAGE Sensitivity				μ V/m					AVERAGE Sensitivity				μ V/m				
Values in the formula for transform factor																	
Measuring antenna cable loss									Measuring antenna cable loss								
Measuring antenna attenuator loss									Measuring antenna attenuator loss								
Measuring antenna balun loss									Measuring antenna balun loss								
Mutual coupling and mismatch loss (30 MHz to 180 MHz)									Mutual coupling and mismatch loss (30 MHz to 180 MHz)								
Antenna factor of the measuring antenna									Antenna factor of the measuring antenna								

7.3.1.5 Statement of results

The results should be presented in tabular form as shown in table 38.

Table 38: Overall results sheet

RECEIVER SENSITIVITY				Date:	PAGE 1 of 1			
Vertical polarization				Horizontal polarization				
MAXIMUM Usable Sensitivity		μ V/m		MAXIMUM Usable Sensitivity		μ V/m		
AVERAGE Usable Sensitivity		μ V/m		AVERAGE Usable Sensitivity		μ V/m		
Expanded uncertainty (95 %)		dB		Expanded uncertainty (95 %)		dB		

7.3.2 Measurement uncertainty for Receiver sensitivity

A fully worked example illustrating the methodology to be used can be found in clause 4 of TR 102 273-1-2 [9].

7.3.2.1 Uncertainty contributions: Stage one: Determination of transform factor

The first stage (determining the transform factor) involves placing a measuring antenna as shown in figure 54 and determining the relationship between the signal generator output power level and the resulting field strength (the shaded areas in figure 54 represent components common to both stages of the test).

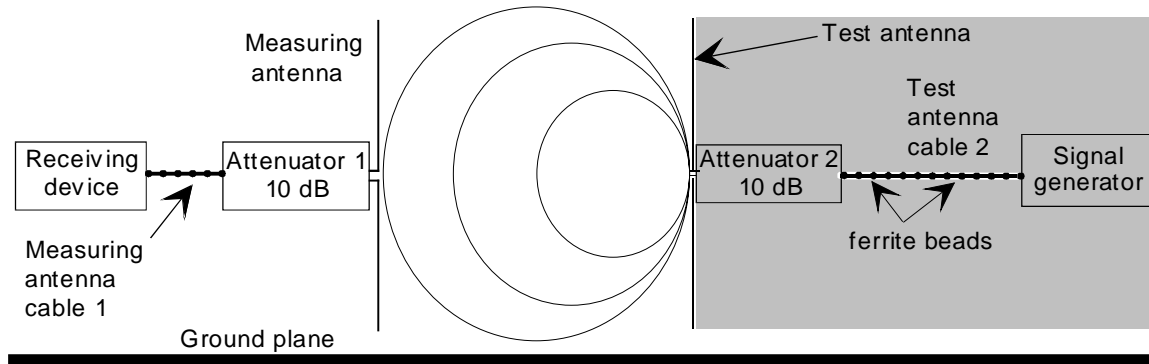

Figure 54: Stage 1: Transform factor

All the uncertainty components which contribute to this stage of the test are listed in table 39. Annex A should be consulted for the sources and/or magnitudes of the uncertainty contributions.

Table 39: Contributions for the transform factor

$u_{j \text{ or } i}$	Description of uncertainty contributions	dB
u_{j36}	mismatch: transmitting part	
u_{j37}	mismatch: receiving part	
u_{j38}	signal generator: absolute output level	0,00
u_{j39}	signal generator: output level stability	
u_{j19}	cable factor: measuring antenna cable	
u_{j19}	cable factor: test antenna cable	
u_{j41}	insertion loss: measuring antenna cable	
u_{j41}	insertion loss: test antenna cable	0,00
u_{j40}	insertion loss: measuring antenna attenuator	
u_{j40}	insertion loss: test antenna attenuator	0,00
u_{j47}	receiving device: absolute level	
u_{j16}	range length	
u_{j02}	reflectivity of absorbing material: measuring antenna to the test antenna	
u_{j44}	antenna: antenna factor of the measuring antenna	
u_{j45}	antenna: gain of the test antenna	
u_{j46}	antenna: tuning of the measuring antenna	
u_{j46}	antenna: tuning of the test antenna	0,00
u_{j22}	position of the phase centre: measuring antenna	
u_{j06}	mutual coupling: measuring antenna to its images in the absorbing material	
u_{j06}	mutual coupling: test antenna to its images in the absorbing material	
u_{j14}	mutual coupling: measuring antenna to its images in the ground plane	
u_{j14}	mutual coupling: test antenna to its images in the ground plane	
u_{j11}	mutual coupling: measuring antenna to the test antenna	
u_{j12}	mutual coupling: interpolation of mutual coupling and mismatch loss correction factors	
u_{j01}	random uncertainty (see note in clause A.18 of TR 102 273-1-2 and note in clause 6.4.7 of TR 102 273-1-1)	

The standard uncertainties from table 39 should be combined by RSS in accordance with clause 5 of TR 102 273-1-1 [8]. This gives the combined standard uncertainty (u_c contributions from the transform factor) for the transform factor in dB.

7.3.2.2 Uncertainty contributions: Stage 2: EUT measurement

The second stage (the EUT measurement) is to determine the minimum signal generator output level which produces the required response from the EUT as shown in figure 55 (the shaded areas represent components common to both stages of the test).

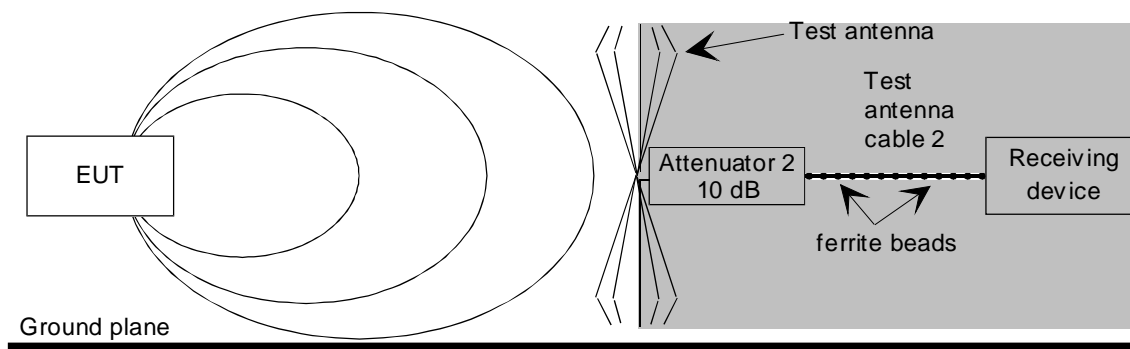

Figure 55: Stage 2: EUT measurement

All the uncertainty components which contribute to this stage of the test are listed in table 40. Annex A should be consulted for the sources and/or magnitudes of the uncertainty contributions.

Table 40: Contributions from the EUT measurement

$u_{j \text{ or } i}$	Description of uncertainty contributions	dB
u_{j36}	mismatch: transmitting part	
u_{j38}	signal generator: absolute output level	0,00
u_{j39}	signal generator: output level stability	
u_{j19}	cable factor: test antenna cable	
u_{j41}	insertion loss: test antenna cable	0,00
u_{j40}	insertion loss: test antenna attenuator	0,00
u_{j20}	position of the phase centre: within the EUT volume	
u_{j21}	positioning of the phase centre: within the EUT over the axis of rotation of the turntable	
u_{j52}	EUT: modulation detection	
u_{j16}	range length	
u_{j01}	reflectivity of absorbing material: EUT to the test antenna	
u_{j45}	antenna: gain of the test antenna	0,00
u_{j46}	antenna: tuning of the test antenna	0,00
u_{j55}	EUT: mutual coupling to the power leads	
u_{j08}	mutual coupling: amplitude effect of the test antenna on the EUT	
u_{j04}	mutual coupling: EUT to its images in the absorbing materials	
u_{j13}	mutual coupling: EUT to its image in the ground plane	
u_{j06}	mutual coupling: test antenna to its images in the absorbing material	
u_{j14}	mutual coupling: test antenna to its image in the ground plane	
u_{j01}	random uncertainty (see note in clause A.18 of TR 102 273-1-2 and note in clause 6.4.7 of TR 102 273-1-1)	

The standard uncertainties from table 40 should be combined by RSS in accordance with clause 5 of TR 102 273-1-1 [8]. This gives the combined standard uncertainty (u_c contribution from the EUT measurement) for the EUT measurement in dB.

7.3.2.3 Expanded uncertainty of the receiver sensitivity measurement

The combined uncertainty of the sensitivity measurement is the combination of the components outlined in clauses 7.3.2.1 and 7.3.2.2. The components to be combined are u_c contribution from the transform factor and u_c contribution from the EUT measurement:

$$u_c = \sqrt{u_{c \text{ contribution from the Transform factor}}^2 + u_{c \text{ contribution from the EUT measurement}}^2} = _, _ \text{ dB} \quad (7.9)$$

The expanded uncertainty is $\pm 1,96 * u_c = \pm _, _ \text{ dB}$ at a 95 % confidence level.

7.3.3 Co-channel rejection

This test is normally carried out using a Test Fixture and as a result has not been considered for this facility.

7.3.4 Adjacent channel selectivity

This test is normally carried out using a Test Fixture and as a result has not been considered for this facility.

7.3.5 Intermodulation immunity

This test is normally carried out using a Test Fixture and as a result has not been considered for this facility.

7.3.6 Blocking immunity in desensitization

This test is normally carried out using a Test Fixture and as a result has not been considered for this facility.

7.3.7 Spurious response immunity to radiated fields

The analysis of this test has not been included in the present document, for this facility.

Annex A: Bibliography

- "Advanced National certificate mathematics", PEDOE, Hodder and Stoughton Volumes I and II.
- "Antenna engineering handbook", R. C. Johnson, H. Jasik.
- "Antennas and radio wave propagation", R. E. Collin, McGraw Hill.
- "Antennas", John D. Kraus, Second edition, McGraw Hill.
- "Analysis of trials on Artificial Human Body", I. L. Gallan and P. R. Brown Interference technology international consultants ltd. Contract ref MC/078.
- "Chambers Science and Technology dictionary", 1988. Published by Chambers Cambridge.
- "Computer simulation and measurements of electromagnetic fields close to phantom Humans", Electricity and magnetism in biology and medicine by Martin Blank, Ed 1993 San Francisco Press.
- "Control of errors on Open Area Test Sites", A. A. Smith Jnr. EMC technology October 1982 page 50-58.
- "A designers guide to shielding", Hewlett Packard: RF and microwave measurement symposium and exhibition.
- "Digital Communications", John G. Proakis, McGraw-Hill International Editions, second edition.
- "The expression of uncertainty in electrical measurement", B3003, November 1987 National Measurement Accreditation Service (NAMAS).
- "Fundamentals of RF and Microwave Power Measurements", Hewlett Packard: Application note 64-1 August 1977.
- "Getting better results from an Open Area Test Site", Joseph DeMarinus.
- "Guide to the evaluation and expression of the uncertainties associated with the results of electrical measurements", Ministry of Defence: 00-26/Issue 2: September 1988.
- "Guide to the Expression of Uncertainty in Measurement", (International Organization for Standardization, Geneva, Switzerland, 1995).
- "Measurement uncertainty generally", Statens Tekniske Provenaeavn, The Danish Accreditation Committee (STP). June 1988 (Danish).
- "Radiowave propagation and antennas for personal communications", K. Siwiak, Artech House Publications.
- "Specifications for equipment's for use in the Land Mobile Service" CEPT Recommendation T/R 24-01.
- "Standard site method for determining antenna factors", A. A. Smith Jr. IEEE transactions EMC. Vol EMC 24 pp 316-322 Aug 1982.
- "Techniques for measuring narrowband and broadband EMI signals using spectrum analysers", Hewlett Packard RF and microwave measurement symposium and exhibition.
- "The telecommunications factbook and illustrated dictionary", Kahn, Delmar publications Inc. New York 1992.
- "Uncertainties of Measurement for NATLAS electrical testing laboratories. NAMAS policy and general notes", National Testing Laboratory Accreditation Scheme (NATLAS), NIS20 July 1986 (English).
- "Use of Simulated Human Bodies in pager receiver sensitivity measurements", K.Siwiak and W.Elliott III. Southcom /92 conference, Orlando 1992. pp 189/92.
- "Usikkerhed pa maleresultater" (Per Bennich, Institute for Product Development: "Uncertainty of measured results"). October 1988. (Danish).
- 50(161) IEC 1990.

- "Vocabulary of metrology", British Standard Institution (BSI): PD 6461: Part 2: September 1980.
- "Wave transmission", F. R. Conner, Arnold 1978.

History

Document history		
Edition 1	February 1998	Publication as ETR 273-3
V1.2.1	December 2001	Publication