

**Electromagnetic compatibility  
and Radio spectrum Matters (ERM);  
Improvement on Radiated Methods  
of Measurement (using test site) and evaluation  
of the corresponding measurement uncertainties;  
Part 5: Striplines**

---



---

**Reference**

RTR/ERM-RP02-057-5

---

**Keywords**analogue, data, measurement uncertainty,  
mobile, radio, testing**ETSI**

---

650 Route des Lucioles  
F-06921 Sophia Antipolis Cedex - FRANCE

Tel.: +33 4 92 94 42 00 Fax: +33 4 93 65 47 16

Siret N° 348 623 562 00017 - NAF 742 C  
Association à but non lucratif enregistrée à la  
Sous-Préfecture de Grasse (06) N° 7803/88

---

**Important notice**

Individual copies of the present document can be downloaded from:

<http://www.etsi.org>

The present document may be made available in more than one electronic version or in print. In any case of existing or perceived difference in contents between such versions, the reference version is the Portable Document Format (PDF). In case of dispute, the reference shall be the printing on ETSI printers of the PDF version kept on a specific network drive within ETSI Secretariat.

Users of the present document should be aware that the document may be subject to revision or change of status. Information on the current status of this and other ETSI documents is available at

<http://portal.etsi.org/tb/status/status.asp>

If you find errors in the present document, send your comment to:

[editor@etsi.fr](mailto:editor@etsi.fr)

---

**Copyright Notification**

No part may be reproduced except as authorized by written permission.  
The copyright and the foregoing restriction extend to reproduction in all media.

© European Telecommunications Standards Institute 2001.  
All rights reserved.

# Contents

Intellectual Property Rights .....	5
Foreword.....	5
1 Scope .....	6
2 References .....	6
3 Definitions, symbols and abbreviations .....	6
3.1 Definitions .....	6
3.2 Symbols.....	10
3.3 Abbreviations .....	13
4 Introduction .....	13
4.1 Open two-plate Stripline test cells.....	15
4.2 Open three-plate Stripline test cells.....	16
4.3 Closed Stripline cell .....	17
5 Uncertainty contributions specific to Stripline test facilities.....	17
5.1 Mutual coupling .....	17
5.2 Characteristic impedance of the Stripline.....	17
5.3 Non-planar nature of the field distribution .....	18
5.4 Field strength measurement.....	19
5.5 Correction factor for the size of the EUT .....	19
5.6 Influence of site effects .....	19
5.7 General discussion.....	20
6 Verification procedure for a Stripline.....	20
6.1 Definition .....	20
6.2 Overview of the verification procedure.....	20
6.2.1 Apparatus required.....	20
6.2.2 Site preparation .....	21
6.2.3 Measurement configuration .....	21
6.2.4 What to record .....	22
6.3 Verification procedure.....	22
6.4 Processing the results of the verification procedure .....	24
6.4.1 Introduction.....	24
6.4.2 Completing the results sheet .....	24
6.5 Report Format .....	25
6.6 Calculation of measurement uncertainty .....	25
6.6.1 Uncertainty contribution: Stage 1: Reference, direct attenuation measurement .....	26
6.6.2 Uncertainty contribution: Stage 2: Stripline attenuation measurement.....	26
6.6.3 Expanded uncertainty of the verification procedure .....	27
7 Test methods .....	28
7.1 Introduction .....	28
7.1.1 Site preparation.....	28
7.1.2 Preparation of the EUT .....	29
7.1.3 Power supplies to the EUT .....	29
7.2 Transmitter tests .....	29
7.2.1 Frequency error.....	29
7.2.2 Effective radiated power .....	29
7.2.3 Spurious emissions .....	29
7.2.4 Adjacent channel power.....	29
7.3 Receiver tests.....	30
7.3.1 Sensitivity tests (30 MHz to 1 000 MHz) .....	30
7.3.1.1 Apparatus required.....	31
7.3.1.2 Method of measurement.....	31
7.3.1.3 Procedure for the completion of the results sheets .....	36
7.3.1.4 Log book entries.....	39

7.3.1.5	Statement of results .....	41
7.3.2	Measurement uncertainty for Receiver sensitivity .....	41
7.3.2.1	Uncertainty contributions: Stage 1: EUT measurement .....	42
7.3.2.2	Uncertainty contributions: Stage 2: Field measurement .....	42
7.3.2.3	Expanded uncertainty for the Receiver sensitivity measurement .....	44
7.3.3	Co-channel rejection .....	44
7.3.4	Adjacent channel selectivity .....	44
7.3.5	Intermodulation immunity .....	44
7.3.6	Blocking immunity or desensitization .....	44
7.3.7	Spurious response rejection .....	44
<b>Annex A:</b>	<b>Bibliography .....</b>	<b>45</b>
History .....		47

---

## Intellectual Property Rights

IPRs essential or potentially essential to the present document may have been declared to ETSI. The information pertaining to these essential IPRs, if any, is publicly available for **ETSI members and non-members**, and can be found in ETSI SR 000 314: *"Intellectual Property Rights (IPRs); Essential, or potentially Essential, IPRs notified to ETSI in respect of ETSI standards"*, which is available from the ETSI Secretariat. Latest updates are available on the ETSI Web server (<http://webapp.etsi.org/IPR/home.asp>).

Pursuant to the ETSI IPR Policy, no investigation, including IPR searches, has been carried out by ETSI. No guarantee can be given as to the existence of other IPRs not referenced in ETSI SR 000 314 (or the updates on the ETSI Web server) which are, or may be, or may become, essential to the present document.

---

## Foreword

This Technical Report (TR) has been produced by ETSI Technical Committee Electromagnetic compatibility and Radio spectrum Matters (ERM).

The present document is part 5 of a multi-part deliverable covering Improvement on radiated methods of measurement (using test site) and evaluation of the corresponding measurement uncertainties, as identified below:

Part 1: "Uncertainties in the measurement of mobile radio equipment characteristics";

Sub-part 1: "Introduction";

Sub-part 2: "Examples and annexes";

Part 2: "Anechoic chamber";

Part 3: "Anechoic chamber with a ground plane";

Part 4: "Open area test site";

**Part 5: "Striplines";**

Part 6: "Test fixtures";

Part 7: "Artificial human beings".

---

# 1 Scope

The present document provides background to the subject of measurement uncertainty and proposes extensions and improvements relevant to radiated measurements. It also details the methods of radiated measurements (test methods for mobile radio equipment parameters and verification procedures for test sites) and additionally provides the methods for evaluating the associated measurement uncertainties.

The present document provides a method to be used together with all the applicable standards and (E)TRs, supports TR 100 027 [8] and can be used with TR 100 028 [7].

The present document covers the test methods for performing radiated measurements on mobile radio equipment in a Stripline test facility and also provides the methods for evaluation and calculation of the measurement uncertainties for each of the measured parameters.

---

# 2 References

For the purposes of this Technical Report (TR), the following references apply:

- [1] ITU-T Recommendation O.41: "Psophometer for use on telephone-type circuits".
- [2] ITU-T Recommendation O.153: "Basic parameters for the measurement of error performance at bit rates below the primary rate".
- [3] IEC 60489-3 (Appendix J 1988): "Methods of measurement for radio equipment used in the mobile services. Part 3: Receivers for A3E or F3E emissions".
- [4] EN 55020 (1994): "Electromagnetic immunity of broadcast receivers and associated equipment".
- [5] ETSI TR 102 273-1-1: "ElectroMagnetic Compatibility and Radio Spectrum Matters (ERM); Improvement on Radiated Methods of Measurement (using test site) and evaluation of the corresponding measurement uncertainties; Part 1: Uncertainties in the measurement of mobile radio equipment characteristics; Sub-part 1: Introduction".
- [6] ETSI TR 102 273-1-2: "ElectroMagnetic Compatibility and Radio Spectrum Matters (ERM); Improvement on Radiated Methods of Measurement (using test site) and evaluation of the corresponding measurement uncertainties; Part 1: Uncertainties in the measurement of mobile radio equipment characteristics; Sub-part 2: Examples and annexes".
- [7] ETSI TR 100 028 (V1.4.1) (parts 1 and 2): "Electromagnetic compatibility and Radio spectrum Matters (ERM); Uncertainties in the measurement of mobile radio equipment characteristics".
- [8] ETSI TR 100 027: "Methods of measurement for private mobile radio equipment".

---

# 3 Definitions, symbols and abbreviations

## 3.1 Definitions

For the purposes of the present document, the following terms and definitions apply:

**accuracy:** this term is defined, in relation to the measured value, in clause 4.1.1; it has also been used in the remainder of the document in relation to instruments

**Audio Frequency (AF) load:** normally a resistor of sufficient power rating to accept the maximum audio output power from the EUT. The value of the resistor is normally that stated by the manufacturer and is normally the impedance of the audio transducer at 1 000 Hz

NOTE: In some cases it may be necessary to place an isolating transformer between the output terminals of the receiver under test and the load.

**AF termination:** any connection other than the audio frequency load which may be required for the purpose of testing the receiver (i.e. in a case where it is required that the bit stream be measured, the connection may be made, via a suitable interface, to the discriminator of the receiver under test)

NOTE: The termination device is normally agreed between the manufacturer and the testing authority and details included in the test report. If special equipment is required then it is normally provided by the manufacturer.

**A-M1:** test modulation consisting of a 1 000 Hz tone at a level which produces a deviation of 12 % of the channel separation

**A-M2:** test modulation consisting of a 1 250 Hz tone at a level which produces a deviation of 12 % of the channel separation

**A-M3:** test modulation consisting of a 400 Hz tone at a level which produces a deviation of 12 % of the channel separation. This signal is used as an unwanted signal for analogue and digital measurements

**antenna:** that part of a transmitting or receiving system that is designed to radiate or to receive electromagnetic waves

**antenna factor:** quantity relating the strength of the field in which the antenna is immersed to the output voltage across the load connected to the antenna. When properly applied to the meter reading of the measuring instrument, yields the electric field strength in V/m or the magnetic field strength in A/m

**antenna gain:** the ratio of the maximum radiation intensity from an (assumed lossless) antenna to the radiation intensity that would be obtained if the same power were radiated isotropically by a similarly lossless antenna

**bit error ratio:** the ratio of the number of bits in error to the total number of bits

**combining network:** network allowing the addition of two or more test signals produced by different sources (e.g. for connection to a receiver input)

NOTE: Sources of test signals are normally connected in such a way that the impedance presented to the receiver is 50  $\Omega$ . Combining networks are designed so that effects of any intermodulation products and noise produced in the signal generators are negligible.

**correction factor:** the numerical factor by which the uncorrected result of a measurement is multiplied to compensate for an assumed systematic error

**confidence level:** the probability of the accumulated error of a measurement being within the stated range of uncertainty of measurement

**directivity:** the ratio of the maximum radiation intensity in a given direction from the antenna to the radiation intensity averaged over all directions (i.e. directivity = antenna gain + losses)

**DM-0:** test modulation consisting of a signal representing an infinite series of "0" bits

**DM-1:** test modulation consisting of a signal representing an infinite series of "1" bits

**DM-2:** test modulation consisting of a signal representing a pseudorandom bit sequence of at least 511 bits in accordance with ITU-T Recommendation O.153

**D-M3:** test signal agreed between the testing authority and the manufacturer in the cases where it is not possible to measure a bit stream or if selective messages are used and are generated or decoded within an equipment

NOTE: The agreed test signal may be formatted and may contain error detection and correction. Details of the test signal are to be supplied in the test report.

**duplex filter:** device fitted internally or externally to a transmitter/receiver combination to allow simultaneous transmission and reception with a single antenna connection

**error of measurement (absolute):** the result of a measurement minus the true value of the measurand

**error (relative):** the ratio of an error to the true value

**estimated standard deviation:** from a sample of  $n$  results of a measurement the estimated standard deviation is given by the formula:

$$\sigma = \sqrt{\frac{\sum_{i=1}^n (x_i - \bar{x})^2}{n-1}}$$

$x_i$  being the  $i^{\text{th}}$  result of measurement ( $i = 1, 2, 3, \dots, n$ ) and  $\bar{x}$  the arithmetic mean of the  $n$  results considered.

A practical form of this formula is:

$$\sigma = \sqrt{\frac{Y - \frac{X^2}{n}}{n-1}}$$

where  $X$  is the sum of the measured values and  $Y$  is the sum of the squares of the measured values.

The term **standard deviation** has also been used in the present document to characterize a particular probability density. Under such conditions, the term **standard deviation** may relate to situations where there is only one result for a measurement.

**expansion factor:** multiplicative factor used to change the confidence level associated with a particular value of a measurement uncertainty

The mathematical definition of the expansion factor can be found in clause D.5.6.2.2 of TR 100 028-2 [7].

**extreme test conditions:** conditions defined in terms of temperature and supply voltage. Tests are normally made with the extremes of temperature and voltage applied simultaneously. The upper and lower temperature limits are specified in the relevant testing standard. The test report states the actual temperatures measured

**error (of a measuring instrument):** the indication of a measuring instrument minus the (conventional) true value

**free field:** field (wave or potential) which has a constant ratio between the electric and magnetic field intensities

**free space:** region free of obstructions and characterized by the constitutive parameters of a vacuum

**impedance:** measure of the complex resistive and reactive attributes of a component in an alternating current circuit

**impedance (wave):** the complex factor relating the transverse component of the electric field to the transverse component of the magnetic field at every point in any specified plane, for a given mode

**influence quantity:** quantity which is not the subject of the measurement but which influences the value of the quantity to be measured or the indications of the measuring instrument

**intermittent operation:** operation where the manufacturer states the maximum time that the equipment is intended to transmit and the necessary standby period before repeating a transmit period

**isotropic radiator:** hypothetical, lossless antenna having equal radiation intensity in all directions

**limited frequency range:** the limited frequency range is a specified smaller frequency range within the full frequency range over which the measurement is made

NOTE: The details of the calculation of the limited frequency range are normally given in the relevant testing standard.

**maximum permissible frequency deviation:** the maximum value of frequency deviation stated for the relevant channel separation in the relevant testing standard

**measuring system:** complete set of measuring instruments and other equipment assembled to carry out a specified measurement task



**measurement repeatability:** the closeness of the agreement between the results of successive measurements of the same measurand carried out subject to all the following conditions:

- the same method of measurement;
- the same observer;
- the same measuring instrument;
- the same location;
- the same conditions of use;
- repetition over a short period of time.

**measurement reproducibility:** the closeness of agreement between the results of measurements of the same measurand, where the individual measurements are carried out changing conditions such as:

- method of measurement;
- observer;
- measuring instrument;
- location;
- conditions of use;
- time.

**measurand:** quantity subjected to measurement

**noise gradient of EUT:** function characterizing the relationship between the RF input signal level and the performance of the EUT, e.g. the SINAD of the AF output signal

**nominal frequency:** one of the channel frequencies on which the equipment is designed to operate

**nominal mains voltage:** the declared voltage or any of the declared voltages for which the equipment was designed

**normal test conditions:** the conditions defined in terms of temperature, humidity and supply voltage stated in the relevant testing standard

**normal deviation:** the frequency deviation for analogue signals which is equal to 12 % of the channel separation

**psophometric weighting network:** as described in ITU-T Recommendation O.41

**polarization:** for an electromagnetic wave, the figure traced as a function of time by the extremity of the electric vector at a fixed point in space

**quantity (measurable):** an attribute of a phenomenon or a body which may be distinguished qualitatively and determined quantitatively

**rated audio output power:** the maximum audio output power under normal test conditions, and at standard test modulations, as declared by the manufacturer

**rated radio frequency output power:** the maximum carrier power under normal test conditions, as declared by the manufacturer

**shielded enclosure:** structure that protects its interior from the effects of an exterior electric or magnetic field, or conversely, protects the surrounding environment from the effect of an interior electric or magnetic field

**SINAD sensitivity:** the minimum standard modulated carrier-signal input required to produce a specified SINAD ratio at the receiver output

**stochastic (random) variable:** variable whose value is not exactly known, but is characterized by a distribution or probability function, or a mean value and a standard deviation (e.g. a measurand and the related measurement uncertainty)

**test load:** the test load is a 50  $\Omega$  substantially non-reactive, non-radiating power attenuator which is capable of safely dissipating the power from the transmitter

**test modulation:** the test modulating signal is a baseband signal which modulates a carrier and is dependent upon the type of EUT and also the measurement to be performed

**trigger device:** circuit or mechanism to trigger the oscilloscope timebase at the required instant. It may control the transmit function or inversely receive an appropriate command from the transmitter

**uncertainty (random):** component of the uncertainty of measurement which, in the course of a number of measurements of the same measurand, varies in an unpredictable way (to be considered as a component for the calculation of the combined uncertainty when the effects it corresponds to have not been taken into consideration otherwise)

**uncertainty (systematic):** component of the uncertainty of measurement which, in the course of a number of measurements of the same measurand remains constant or varies in a predictable way

**uncertainty (limits of uncertainty of a measuring instrument):** the extreme values of uncertainty permitted by specifications, regulations etc. for a given measuring instrument

NOTE: This term is also known as "tolerance".

**uncertainty (standard):** an expression characterizing, for each individual uncertainty component, the uncertainty for that component

It is the standard deviation of the corresponding distribution.

**uncertainty (combined standard):** the combined standard uncertainty is calculated by combining appropriately the standard uncertainties for each of the individual contributions identified in the measurement considered or in the part of it, which has been considered

NOTE: In the case of additive components (linearly combined components where all the corresponding coefficients **are equal to one**) and when all these contributions are independent of each other (stochastic), this combination is calculated by using the Root of the Sum of the Squares (the RSS method). A more complete methodology for the calculation of the combined standard uncertainty is given in annex D, see in particular clause D.3.12, of TR 100 028-2 [7].

**uncertainty (expanded):** The expanded uncertainty is the uncertainty value corresponding to a specific confidence level different from that inherent to the calculations made in order to find the combined standard uncertainty.

The combined standard uncertainty is multiplied by a constant to obtain the expanded uncertainty limits (see clause 5.3 of TR 100 028-1 [7], and also clause D.5 (and more specifically clause D.5.6.2) of TR 100 028-2 [7]).

**upper specified AF limit:** the maximum audio frequency of the audio pass-band. It is dependent on the channel separation

**wanted signal level:** for conducted measurements a level of +6 dB $\mu$ V emf referred to the receiver input under normal test conditions. Under *extreme test conditions* the value is +12 dB $\mu$ V emf

NOTE: For analogue measurements the wanted signal level has been chosen to be equal to the limit value of the measured usable sensitivity. For bit stream and message measurements the wanted signal has been chosen to be +3 dB above the limit value of measured usable sensitivity.

## 3.2 Symbols

For the purposes of the present document, the following symbols apply:

$\beta$	$2\pi/\lambda$ (radians/m)
$\gamma$	incidence angle with ground plane ( $^{\circ}$ )
$\lambda$	wavelength (m)
$\phi_H$	phase angle of reflection coefficient ( $^{\circ}$ )
$\eta$	$120\pi$ Ohms - the intrinsic impedance of free space ( $\Omega$ )
$\mu$	permeability (H/m)

$AF_R$	Antenna Factor of the receive antenna (dB/m)
$AF_T$	Antenna Factor of the transmit antenna (dB/m)
$AF_{TOT}$	mutual coupling correction Antenna Factor (dB)
$c$	calculated on the basis of given and measured data
$C_{cross}$	Cross correlation coefficient
$d$	derived from a measuring equipment specification
$D(\theta, \phi)$	Directivity of the source
$d$	distance between dipoles (m)
$\delta$	skin depth (m)
$d_1$	an antenna or EUT aperture size (m)
$d_2$	an antenna or EUT aperture size (m)
$d_{dir}$	path length of the direct signal (m)
$d_{refl}$	path length of the reflected signal (m)
$E$	Electric field intensity (V/m)
$E_{DH}^{max}$	calculated maximum electric field strength in the receiving antenna height scan from a half wavelength dipole with 1 pW of radiated power (for horizontal polarization) ( $\mu\text{V}/\text{m}$ )
$E_{DV}^{max}$	calculated maximum electric field strength in the receiving antenna height scan from a half wavelength dipole with 1 pW of radiated power (for vertical polarization) ( $\mu\text{V}/\text{m}$ )
$e_{ff}$	antenna efficiency factor
$\phi$	angle ( $^\circ$ )
$\Delta f$	bandwidth (Hz)
$f$	frequency (Hz)
$G(\theta, \phi)$	Gain of the source (which is the source directivity multiplied by the antenna efficiency factor)
$H$	magnetic field intensity (A/m)
$I_0$	the (assumed constant) current (A)
$I_m$	the maximum current amplitude
$k$	$2\pi/\lambda$
$k$	a factor from Student's t distribution
$k$	Boltzmann's constant ( $1,38 \times 10^{-23}$ Joules/ $^\circ$ Kelvin)
$K$	relative dielectric constant
$l$	the length of the infinitesimal dipole (m)
$L$	the overall length of the dipole (m)
$l$	the point on the dipole being considered (m)
$m$	measured
$p$	power level value
$Pe_{(n)}$	Probability of error n
$Pp_{(n)}$	Probability of position n
$P_r$	antenna noise Power (W)
$P_{rec}$	Power received (W)
$P_t$	Power transmitted (W)
$\theta$	angle ( $^\circ$ )
$\rho$	reflection coefficient
$r$	the distance to the field point (m)
$\rho_g$	reflection coefficient of the generator part of a connection
$\rho_l$	reflection coefficient of the load part of the connection
$R_s$	equivalent surface Resistance ( $\Omega$ )
$\sigma$	conductivity (S/m)
$\sigma$	standard deviation
$r$	indicates rectangular distribution
$SNR_{b^*}$	Signal to Noise Ratio at a specific BER
$SNR_b$	Signal to Noise Ratio per bit
$T_A$	antenna Temperature ( $^\circ$ Kelvin)
$u$	indicates U-distribution
$U$	the expanded Uncertainty corresponding to a confidence level of $x\%$ : $U = k \times u_c$

$u_c$	the combined standard uncertainty
$u_i$	general type A standard uncertainty
$u_{i01}$	random uncertainty
$u_j$	general type B uncertainty
$u_{j01}$	reflectivity of absorbing material: EUT to the test antenna
$u_{j02}$	reflectivity of absorbing material: substitution or measuring antenna to the test antenna
$u_{j03}$	reflectivity of absorbing material: transmitting antenna to the receiving antenna
$u_{j04}$	mutual coupling: EUT to its images in the absorbing material
$u_{j05}$	mutual coupling: de-tuning effect of the absorbing material on the EUT
$u_{j06}$	mutual coupling: substitution, measuring or test antenna to its image in the absorbing material
$u_{j07}$	mutual coupling: transmitting or receiving antenna to its image in the absorbing material
$u_{j08}$	mutual coupling: amplitude effect of the test antenna on the EUT
$u_{j09}$	mutual coupling: de-tuning effect of the test antenna on the EUT
$u_{j10}$	mutual coupling: transmitting antenna to the receiving antenna
$u_{j11}$	mutual coupling: substitution or measuring antenna to the test antenna
$u_{j12}$	mutual coupling: interpolation of mutual coupling and mismatch loss correction factors
$u_{j13}$	mutual coupling: EUT to its image in the ground plane
$u_{j14}$	mutual coupling: substitution, measuring or test antenna to its image in the ground plane
$u_{j15}$	mutual coupling: transmitting or receiving antenna to its image in the ground plane
$u_{j16}$	range length
$u_{j17}$	correction: off boresight angle in the elevation plane
$u_{j18}$	correction: measurement distance
$u_{j19}$	cable factor
$u_{j20}$	position of the phase centre: within the EUT volume
$u_{j21}$	positioning of the phase centre: within the EUT over the axis of rotation of the turntable
$u_{j22}$	position of the phase centre: measuring, substitution, receiving, transmitting or test antenna
$u_{j23}$	position of the phase centre: LPDA
$u_{j24}$	stripline: mutual coupling of the EUT to its images in the plates
$u_{j25}$	stripline: mutual coupling of the three-axis probe to its image in the plates
$u_{j26}$	stripline: characteristic impedance
$u_{j27}$	stripline: non-planar nature of the field distribution
$u_{j28}$	stripline: field strength measurement as determined by the three-axis probe
$u_{j29}$	stripline: transform factor
$u_{j30}$	stripline: interpolation of values for the transform factor
$u_{j31}$	stripline: antenna factor of the monopole
$u_{j32}$	stripline: correction factor for the size of the EUT
$u_{j33}$	stripline: influence of site effects
$u_{j34}$	ambient effect
$u_{j35}$	mismatch: direct attenuation measurement
$u_{j36}$	mismatch: transmitting part
$u_{j37}$	mismatch: receiving part
$u_{j38}$	signal generator: absolute output level
$u_{j39}$	signal generator: output level stability
$u_{j40}$	insertion loss: attenuator
$u_{j41}$	insertion loss: cable
$u_{j42}$	insertion loss: adapter
$u_{j43}$	insertion loss: antenna balun
$u_{j44}$	antenna: antenna factor of the transmitting, receiving or measuring antenna
$u_{j45}$	antenna: gain of the test or substitution antenna
$u_{j46}$	antenna: tuning

$u_{j47}$	receiving device: absolute level
$u_{j48}$	receiving device: linearity
$u_{j49}$	receiving device: power measuring receiver
$u_{j50}$	EUT: influence of the ambient temperature on the ERP of the carrier
$u_{j51}$	EUT: influence of the ambient temperature on the spurious emission level
$u_{j52}$	EUT: degradation measurement
$u_{j53}$	EUT: influence of setting the power supply on the ERP of the carrier
$u_{j54}$	EUT: influence of setting the power supply on the spurious emission level
$u_{j55}$	EUT: mutual coupling to the power leads
$u_{j56}$	frequency counter: absolute reading
$u_{j57}$	frequency counter: estimating the average reading
$u_{j58}$	salty man/salty-lite: human simulation
$u_{j59}$	salty man/salty-lite: field enhancement and de-tuning of the EUT
$u_{j60}$	test fixture: effect on the EUT
$u_{j61}$	test fixture: climatic facility effect on the EUT
$V_{direct}$	received voltage for cables connected via an adapter (dB $\mu$ V/m)
$V_{site}$	received voltage for cables connected to the antennas (dB $\mu$ V/m)
$W_0$	radiated power density (W/m <sup>2</sup> )

### 3.3 Abbreviations

For the purposes of the present document, the following abbreviations apply:

AF	Audio Frequency
BER	Bit Error Ratio
emf	electromotive force
EUT	Equipment Under Test
LPDA	Log Periodic Dipole Antenna
m	measured
r	indicates rectangular distribution
RF	Radio Frequency
RSS	Root-Sum-of-the-Squares
TEM	Transverse Electro-Magnetic
u	indicates U-distribution
VSWR	Voltage Standing Wave Ratio

---

## 4 Introduction

A stripline is essentially a transmission line in the same sense as a coaxial cable (see clause 9.2 of TR 102 273-1-1 [5]). It sets up an electromagnetic field between the plates in a similar way that a coaxial cable sets up fields between inner and outer conductors. In both cases, the basic mode of propagation is in the form of a Transverse ElectroMagnetic wave (TEM) i.e. a wave which possesses single electric and magnetic field components, transverse to the direction of propagation, as in the case of propagation in free-space. Stripline test facilities, therefore, are transmission lines constructed with their plates separated sufficiently for an EUT to be inserted between them. The polarization of the electric field vector is as shown in figure 1.

There are various types of Stripline test facilities, mainly comprising either two or three plates. The three-plate designs are available as either open or closed i.e. the fields can either extend into the region surrounding the line or they can be totally enclosed by metal side plates.

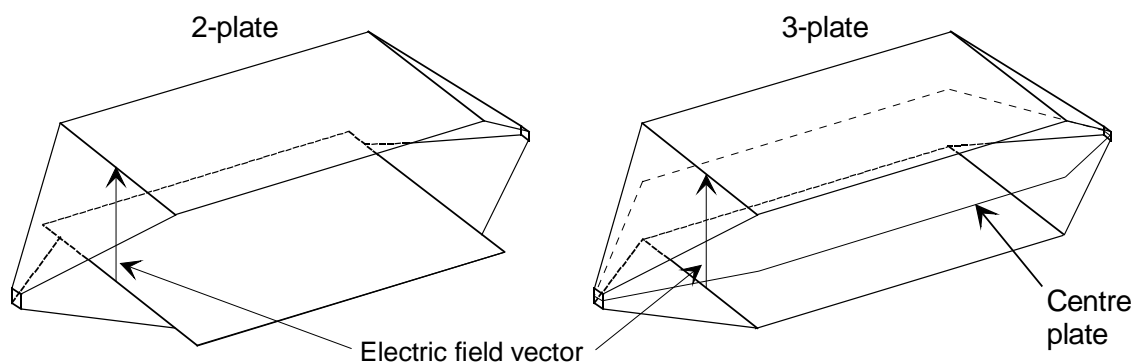

**Figure 1: Typical open two-plate and three-plate Stripline test facilities.**

Typical two and three-plate open Striplines are shown in figure 1. Whereas a typical closed Stripline (alternatively termed TEM cell) is shown in figure 2. For the three-plate open cell, the middle plate can be either symmetrically spaced between the outer two (as shown in figure 1), or offset more towards the bottom or top plate.

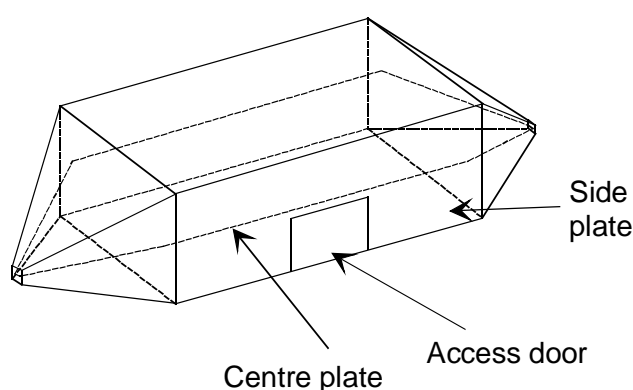

**Figure 2: A typical closed Stripline test facility**

For all versions of the open Stripline, some portion of the electromagnetic field extends beyond the physical extent of the line since the sides are not enclosed by metal. As a direct consequence, the performance of an open cell is dependent not only on its construction but also on its immediate surroundings - the cell interacting with physical objects which may be present e.g. test equipment, people, etc., as well as suffering from the influences of external electrical effects such as local ambient signals and resonances associated with the room in which the cell is located. Shielding the room has the benefit of eliminating ambient signals but can seriously increase the magnitude of the room resonance effects (the room acting like a large resonant waveguide cavity). Where a shielded room is used to house the open Stripline, strategic use of absorbing panels (for damping resonance effects and generally reducing other interactions) is regarded as essential. Use of an open Stripline in a non-shielded room may cause interference to others.

The closed TEM cell is constructed using 5 plates, the central conductor in addition to the four sides. Benefits, resulting from the enclosure of all four sides, include the elimination of effects due to external reflections, local ambient signals and room resonances suffered by the open Stripline. Drawbacks include internally generated resonances and a dramatic cost increase relative to the equivalent open version. The available designs of closed cell include the so-called GTEM cell (a broadband version of the TEM cell).

Both open Striplines and TEM cells have tapered sections at either one or both ends, although it is more usual for open Striplines to taper at both ends. With tapers at both ends, one will be loaded with a terminating resistor whereas, if only one end is tapered, the non-tapered end is usually terminated with an evenly distributed resistive load and RF absorbing material(s). The terminating resistor/absorber reduces the magnitudes of internal standing waves and resonances and absorbs unwanted propagation modes.

These unwanted modes can arise from the construction of the feed taper as well as from the input connector and any internal objects (supports, spacers, EUT, etc.), limiting the broadband performance of a Stripline. The limiting effect that unwanted modes (and, in some cases, internal resonances and reflections) have on the broadband performance of a Stripline is disturbance of the plane wave nature of the internal field. By using the Stripline below the theoretical "cut-off" frequency for the first of these unwanted modes, the major problems associated with moding can be significantly reduced.

For a two-plate open Stripline the cut-off frequency corresponds to a plate spacing of 0,5 wavelength which imposes a basic limitation on the largest size of EUT that the line can accommodate. Compounding the 0,5 wavelength maximum plate spacing problem is that for accurate testing, in terms of uniformity of field i.e. its purity of polarization, impedance, etc., and to reduce the interaction between the EUT and the metal plates, a general rule of using only the middle third of the Stripline height has evolved. This implies a maximum EUT size of one sixth of a wavelength. When the frequency range of interest enters the GHz region (where the wavelengths are less than 300 mm) the permitted size of the items for testing can be a severe limiting factor. Furthermore, due to this upper frequency limit on Stripline usage, any tests involving large bandwidths i.e. spurious emission testing or broadband degradation tests (particularly spurious response rejection) are not possible. This is a serious limitation for Striplines in general.

## 4.1 Open two-plate Stripline test cells

Open two-plate Stripline cells can have equal plate widths or, as illustrated in figure 1, have a lower plate that is wider than its top plate. Electrically, the effect of having the lower plate wider than the top is to prevent concentration and bowing of the fields at the edges of the plates. The fringing fields from the upper plate can, as a result, meet the lower plate at angles far closer to 90°, thereby increasing the uniformity of the generated field. This is illustrated in figure 3.

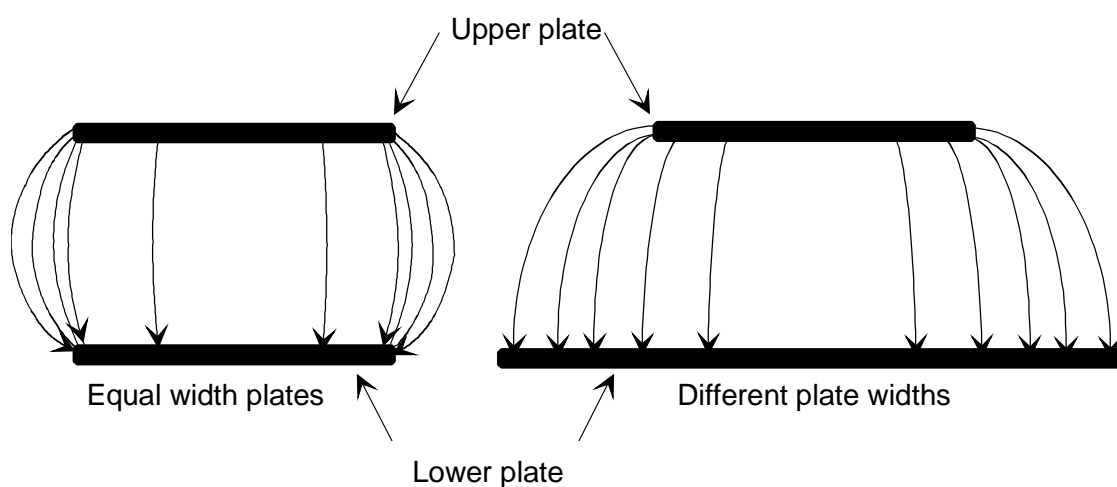

**Figure 3: The fringing fields at the edges of a two-plate open Stripline**

A specific example of the open two-plate Stripline is that described in EN 55020 [4]. As shown in the outline drawing (see figure 4), the EN 55020 [4] Stripline measures 2,76 m in overall length with a height of 0,8 m, a lower plate width of 0,9 m and an upper plate width of 0,6 m.

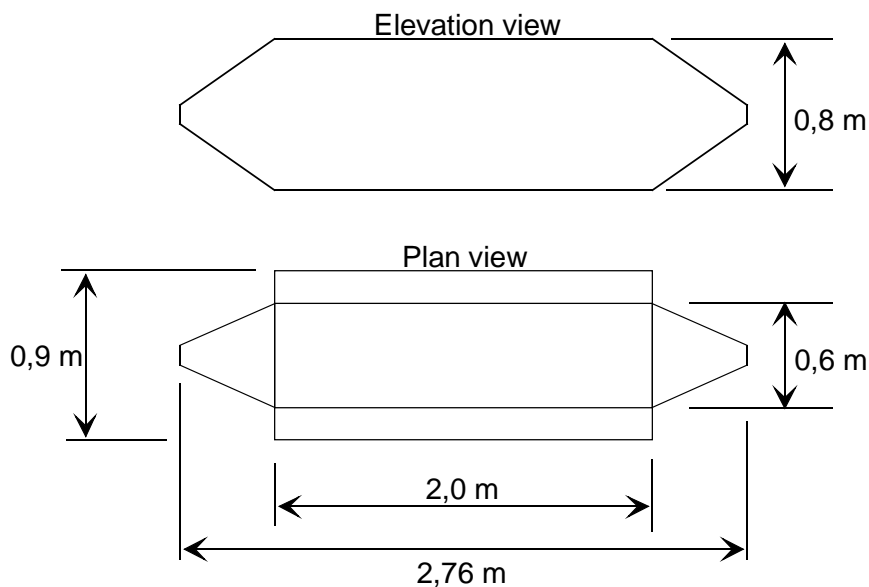
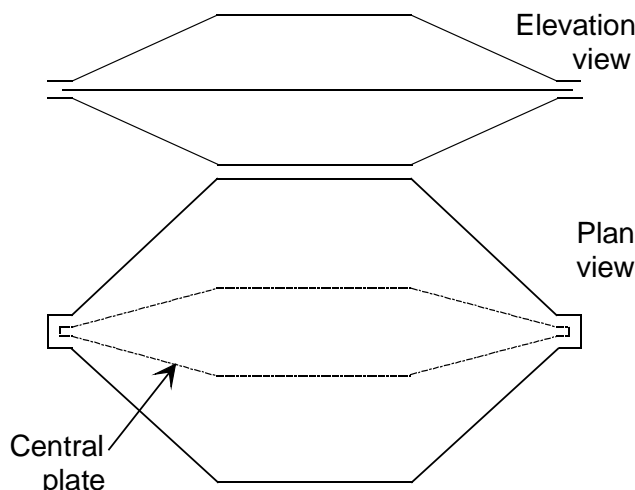

**Figure 4: Outside dimensions of EN 55020 [4] Stripline**

For this Stripline cell, the characteristic impedance is  $150\ \Omega$  and this high impedance therefore needs careful matching to the  $50\ \Omega$  lines which make up the associated items of test equipment. This is achieved by use of a resistive matching network. The operating frequency band for this cell is up to 150 MHz.

## 4.2 Open three-plate Stripline test cells

An example of this type of cell is that detailed in IEC 60489-3 [3] Appendix J. This cell possesses a symmetrically located central plate as illustrated in figure 5.

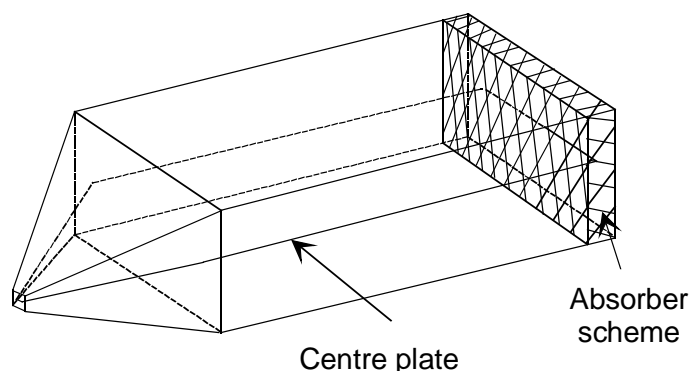

**Figure 5: Open three-plate Stripline as detailed in IEC 604893 [3] Appendix J 1988**

IEC 60489-3 [3] Appendix J gives two different variants of this model. One model, of overall length 4,2 m, has a useful frequency range of 1 MHz to 100 MHz, whilst the second model, of length 2,2 m, is used from 1 MHz to 200 MHz. Both models share a large frequency range, but there is no redundancy, since the lower frequency version allows larger EUT to be tested up to its frequency limit of 100 MHz.

The plates are spaced apart by insulating supports which are also used underneath the base plate. The EUT is placed midway between the base and central plates.

Another version of the open three-plate cell is the open ended type, where the open end is terminated in an evenly distributed resistive load and RF absorbing material(s). This is shown in figure 6.



**Figure 6: A typical open ended three-plate open Stripline**

This type of cell attempts to improve the limited bandwidth of other cells by absorbing internal resonances, higher order modes, etc.

The construction of the feed taper, as well as the connector itself, are, however, vital to the broadband performance of this cell. Unwanted modes can be generated by the feed and these have a direct effect on the input impedance of the cell. They are difficult to absorb at the open end since their wave impedances differ, not only from the main transverse electromagnetic wave, but also from each other. Therefore, an absorbing scheme effective for one mode will not necessarily work for any of the other modes.



These modes are a function of the frequency used and the ratio of line width to line height. They can have field components in the longitudinal direction of the line and are capable of propagation if the cross-sectional dimensions of the line i.e. width or height, become larger than half a wavelength at the operating frequency.

### 4.3 Closed Stripline cell

A typical three-plate closed Stripline or TEM cell (also known as a Crawford cell) is illustrated in figure 2 from which it can be seen that, as in the case of the open cell above, the centre conducting plate will need supporting by dielectric columns or foam. A door is provided for access to the test area which is located in one half of the line. The spacing of the plates is usually arranged to provide a characteristic impedance for the Stripline of 50  $\Omega$ .

As a guide to the frequency range, a Stripline as shown in figure 2 measuring 4 m long by a cross section of 2 m square will be usable to over 100 MHz. In general terms its cost will be approximately a factor of 20 times that of a two-plate open Stripline equivalent covering the same band.

This closed Stripline shields its test fields from ambient signals as well as the effects of reflections from test equipment, room resonances, movement of personnel, etc. The enclosing metal walls can lead to high amplitude resonances which can disturb the required field distributions.

---

## 5 Uncertainty contributions specific to Stripline test facilities

Several different types of Stripline test facilities are discussed in clause 4 but of these, only one has been found to be in regular use in European test houses. This is the open two-plate Stripline as detailed in EN 55020 [4]. The following review of uncertainty contributions specific to Stripline test facilities is, therefore, strictly limited to that particular two-plate design although most will be present in other types.

### 5.1 Mutual coupling

The close proximity of the metal plates can produce detuning effects and imaging of the EUT within the Stripline. These effects are generally termed mutual coupling effects. Imaging can be particularly serious since it can result in changes to the radiation pattern, gain and input impedance of the EUT. Essentially these effects concern only an EUT and a three-axis probe (used to measure field strength within the line). The only other device inserted into the line during either the verification procedure or any of the test methods is a monopole. Since this deliberately uses the lower metal plate as a ground plane, the mutual coupling effects on this device are considered negligible.

The effects on the electrical characteristics of the EUT and three-axis probe due to the degree of mutual coupling are estimated in TR 102 273-1-1 [5] annex A and the uncertainty contributions which result are given representative symbols as follows:

- $u_{j24}$  is used for the uncertainty contribution associated with the mutual coupling of the EUT to its images in the plates of the Stripline;
- $u_{j25}$  is used for the uncertainty contribution associated with the mutual coupling of the three-axis probe to its images in the plates of the Stripline.

### 5.2 Characteristic impedance of the Stripline

Virtually all test devices, whether an EUT, antenna, field probe, etc., are designed to operate in free-space i.e. their radiating structures are matched to 377  $\Omega$ . Therefore when used in environments which have different impedances e.g. Stripline test facilities, the matching schemes employed within these devices will see a changed load impedance. This gives rise to uncertainties in detected levels.

Symbolically:

- $u_{j26}$  is used for the uncertainty contribution associated with characteristic impedance of the Stripline.

### 5.3 Non-planar nature of the field distribution

Ideally, all EUTs should be tested in planar electric fields i.e. fields which are uniform in both phase and amplitude. However, various effects disturb the required field distribution in a Stripline, amongst which are non-TEM (also termed: higher order) modes, reflections, room resonances, etc.

The feed point and the tapered sections at both ends of the EN 55020 [4] Stripline can be sources of these effects. For the feed point, the wave launched will naturally exhibit a spherical wavefront. This can result in a considerable variation in phase across the width of the line, particularly at the transition between the tapered feed section and the start of the parallel plate region. Also at this junction between tapered and parallel sections, field interference can be generated at the corners. Both effects are shown in figure 7.

Non-TEM, higher order modes can be generated at the feed point as a direct result of the taper in the vertical plane (i.e. the taper which gives the separation of the plates). The problem arises because the electric field is not perpendicular, but is curved in the vertical plane. Components of the electric field therefore exist in the direction of propagation down the line itself and these, in turn, give rise to transverse magnetic modes. Higher order modes can additionally be created by the dielectric columns separating the two plates, the introduction of an EUT, etc.

These modes only start to be a major problem when their propagation is supported by the line i.e. when any cross sectional dimension exceeds half a wavelength. Therefore, by limiting the usable frequency range of the EN 55020 [4] Stripline to 150 MHz this problem can be greatly reduced. This is not to say that the modes will not be generated at all. They will exist locally and disrupt the field distribution in that region, but they will be subject to strong attenuation by the line. The introduction of an EUT can equally well generate these modes and disturb the uniformity of the field in the region around itself.

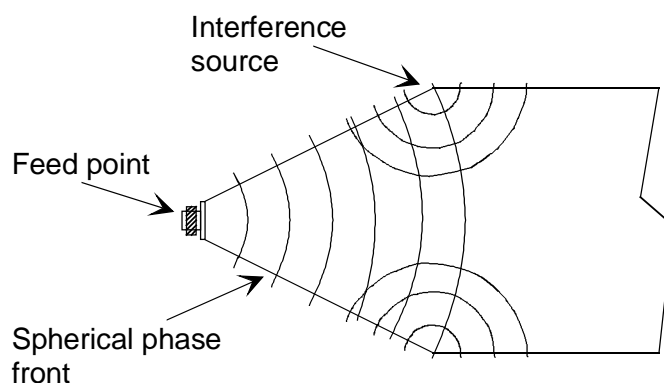

**Figure 7: Illustration of the interference sources at the intersection of tapered and parallel regions**

Further field disruption will occur should the EUT have a large continuous metal content, since the voltage gradient across the Stripline will be changed in the regions to either side. Where an irregularly shaped EUT is rotated within the Stripline for testing against a different polarization, this already changed field strength will change further - adding to measurement uncertainties.

The EN 55020 [4] test facility needs a large room in which to be housed. Room resonances can be encountered at all frequencies satisfying the following formula when the room possesses rectangular cross-sections:

$$f = 150 \sqrt{\left(\frac{x}{l}\right)^2 + \left(\frac{y}{b}\right)^2 + \left(\frac{z}{h}\right)^2} \text{ MHz} \quad (5.1)$$

Here  $l$ ,  $b$  and  $h$  are the length, breadth and height of the room in m and  $x$ ,  $y$  and  $z$  are mode numbers. The only condition limiting the use of this formula is that only one of  $x$ ,  $y$  or  $z$  can be zero at any one time.

For a room measuring  $8 \text{ m} \times 8 \text{ m} \times 4 \text{ m}$ , there are 25 resonant frequencies within the band 26,5 MHz to 120,1 MHz. This shows that, in principle, room resonances can pose major problems. Their effects are worse for rooms which are metal lined (for shielding from ambient signals). In this condition, the room acts like a waveguide and will possess high Q-factors for some or all resonant frequencies. Their effects are to put sharp spikes into the field strength variation with frequency within the cells. In general, these can only be damped by the use of absorbing material placed around the cell.

Other factors which can contribute to disturbance of the field include cabling (in terms of reflections and its possible parasitic effect) and local ambient signals. In general, to keep cabling problems to a minimum, these should be as short as possible within the Stripline, gain access to the test area via small holes in the bottom plate and be heavily loaded with ferrite beads. To completely nullify ambient signals, a shielded room is required but it should be borne in mind that such a room can provide extremely sharp resonances.

$u_{j27}$  is used for the uncertainty contribution associated with the non-planar nature of the field distribution within the Stripline which results from all the disturbing sources.

## 5.4 Field strength measurement

A three-axis probe or a monopole can be optionally used in test methods to measure the field strength within the Stripline during, for example, sensitivity measurements. Alternatively, the value of the Stripline's transform factor (i.e. the relationship between the input power to the Stripline and the resulting field strength in dB $\mu$ V/m) derived in the verification procedure can be used to calculate its value.

For the case of the three-axis probe, however, the field strength reading is subject to an uncertainty which is usually declared by the manufacturer.

$u_{j28}$  is used for the uncertainty contribution associated with the field strength measurement in the Stripline as determined by the 3-axis probe.

The Stripline's transform factor is derived during the verification procedure, so for cases in which it is used to determine the field strength, the associated uncertainty contribution is the combined standard uncertainty,  $u_c$ , of the verification procedure.

$u_{j29}$  is used for the uncertainty contribution associated with the derivation of the transform factor for the Stripline in the verification procedure.

For test methods in which the transform factor is used, the exact transform factor value can be used when the test frequency corresponds to a spot frequency in the verification procedure. However, in the majority of cases, the value will need to be interpolated from the spot frequency values.

$u_{j30}$  is used for the uncertainty contribution associated with the interpolation of values for the transform factor of the Stripline.

For the case of the monopole, the antenna factor of the monopole needs to be known in order to convert the received signal level into field strength. There is an uncertainty associated with the knowledge of the value of the antenna factor.

$u_{j31}$  is used for the uncertainty contribution associated with the antenna factor of the monopole.

## 5.5 Correction factor for the size of the EUT

The height of the EUT within the Stripline distorts the field strength. In EN 55020 [4], correction figures are given to allow for this effect. These figures are, however, subject to uncertainty.

$u_{j32}$  is used for the uncertainty contribution associated with the correction factor for the size of the EUT in the Stripline.

## 5.6 Influence of site effects

Energy is radiated by the EN 55020 [4] Stripline from its open sides. This not only represents a power loss from the facility but also serves as an interference source, by giving rise to possible outside reflections. As a consequence, external objects can influence the results of measurements. To counter this effect, recommended usage of the Stripline involves placing a screen of absorber around its open sides as well as raising the whole cell at least 0,8 m above the ground and ensuring it is no closer than 0,8 m to the ceiling. Should any or all of these recommendations be changed during the two stages of a test method, then the site could influence the two parts of the test differently. Equally, if the recommendations are not observed in the Stripline attenuation part of the verification procedure, the site will influence the measured attenuation values.

$u_{j33}$  is used for the uncertainty contribution associated with the influence of site effects on the Stripline.

## 5.7 General discussion

The performance of an EUT as measured in a Stripline can differ significantly from the performance as measured on either an OATS or in an Anechoic Chamber. The generation of transverse electric and magnetic (waveguide-type) modes is not representative of testing conditions on those alternative test sites and indeed is far from occurring when the EUT is in normal use: their generation is simply a result of the boundary conditions imposed by the upper and lower plates between which the EUT is placed. Given all the uncertainties associated with the uniformity of field strength, room resonances, limited bandwidth/EUT size in addition to the lack of correspondence with real-life or other test sites, Striplines are not a recommended means of making general radiated measurements on radio equipment.

---

## 6 Verification procedure for a Stripline

This verification procedure applies only to the open two-plate Stripline detailed in EN 55020 [4].

### 6.1 Definition

**Transform factor** is the term which relates the Stripline's input power (dBm) to the resulting electric field strength (dB $\mu$ V/m) between the plates. It is specified in dB.

### 6.2 Overview of the verification procedure

The verification procedure involves mounting a monopole antenna through a hole in the lower plate of the Stripline and measuring the coupled power to it when a signal is fed into the input connector of the Stripline.

The procedure involves two stages. Initially, the cables which connect to both the Stripline input and the monopole output are joined directly together (via an adapter if necessary) to establish a reference signal level. The cables are then connected to the Stripline and monopole and the coupled signal level measured, thereby allowing comparison with the level of the direct reference. This form of measurement has similarities to that of measuring site attenuation in both types of Anechoic Chamber and on Open Area Test Sites.

In a manner similar to site attenuation measurements, the position of the monopole is varied within the Stripline to gauge performance over a volume rather than at a single position.

**NOTE:** The drilling of holes in the base plate (to accommodate the monopole) should have no detrimental effect on the performance of the Stripline as long the diameters of the holes do not exceed 0,1 wavelength at the highest frequency of operation.

#### 6.2.1 Apparatus required

- ferrite beads;
- connecting cables;
- attenuator pads (10 dB);
- receiving device (measuring receiver or spectrum analyser);
- signal generator;
- monopole antenna;
- EN 55020 [4] stripline.

Details of all the items of test equipment should be recorded in the results sheet (see table 2).

## 6.2.2 Site preparation

The lower plate of the Stripline should be drilled prior to starting the verification procedure with five holes of a suitable diameter for the monopole to pass through. Their relative positions and spacing should be as shown in figure 8, where  $d = 0,2$  m.

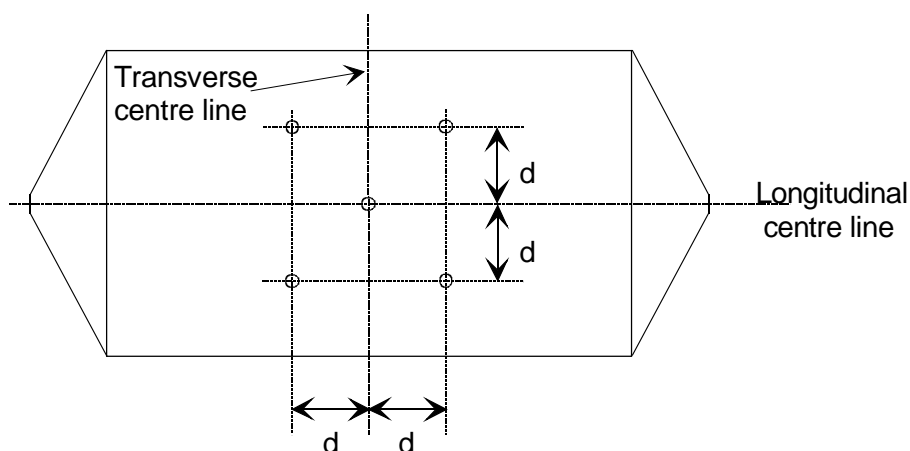

**Figure 8: Hole pattern in underside of Stripline lower plate**

Prior to the start of the verification procedure, system checks should be made on the test equipment to be used. All items of test equipment where appropriate, should be connected to power supplies, switched on and allowed adequate time to stabilize, as recommended by the manufacturers. Where a stabilization period is not given by the manufacturer, 30 minutes should be allowed.

The RF cables should be dressed with ferrite beads, spaced at 0,15 m intervals, for their entire lengths. They should be routed directly away from the Stripline - the feed cable in line with the Striplines axis, the receiving device cable at right angles to the axis.

Calibration data for all items of test equipment should be valid and readily available.

The Stripline should be placed on non conducting supports at least 0,8 m above the floor and not closer than 0,8 m to the ceiling. When used inside a room (whether screened or not), continuous lines of vertical panels covered in absorbing material should be placed between the open sides of the Stripline and the walls. The absorbing material should provide an adequate level of absorption (typically 15 dB minimum reflectivity at all frequencies from 30 MHz to 150 MHz).

## 6.2.3 Measurement configuration

During the verification procedure, the monopole is placed in five different positions within the Stripline. These positions are indicated in figure 9 and correspond to the holes shown in figure 8.

Details of the monopole

When installed in the Stripline, the length of the monopole should be equal to  $0,2 \text{ m} \pm 0,002 \text{ m}$ . Its diameter should be a maximum of 0,002 m and it should be straight to within  $\pm 0,002 \text{ m}$ . It should make an angle of  $90,0^\circ \pm 2,0^\circ$  with respect to the lower Stripline plate. For convenience, it may be possible to solder the monopole wire to, for example, an N-type bulkhead connector which could then be affixed to the underside of the Stripline's lower plate via the fixing holes in its bulkhead mounting plate.

**NOTE:** The fixing holes obviously require further drilling of the Stripline plate, but, as stated above, provided their diameters do not exceed 0,1 wavelength at the highest frequency of use, the performance of the line should not be affected.

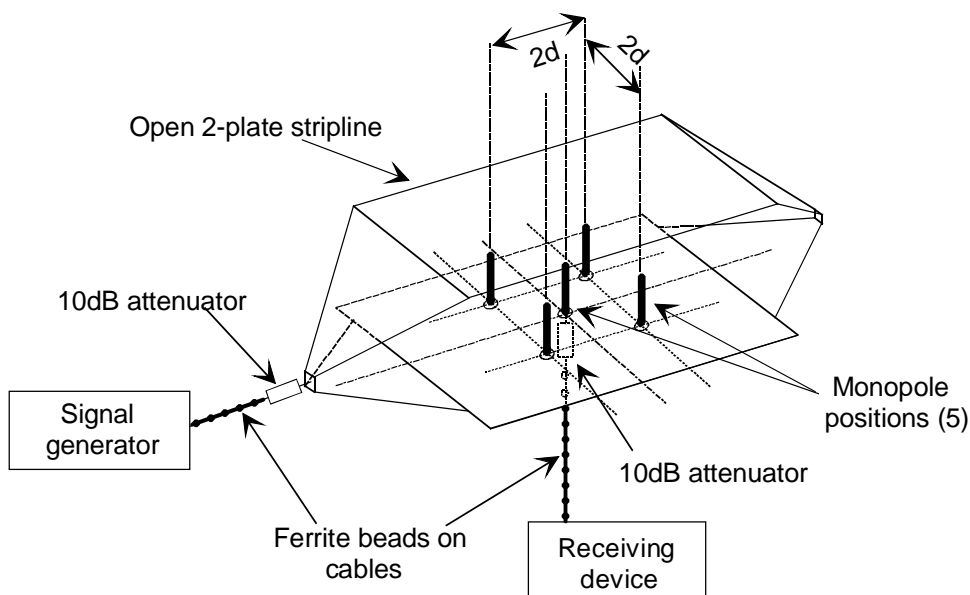

Figure 9: Equipment configuration for Stripline verification tests

### 6.2.4 What to record

During the procedure the ambient temperature and relative humidity should be recorded.

Also during the procedure, the output level of the signal generator, the received level and the tuned frequency should be noted, along with details of ALL equipment used - signal generator, receiving device, cables, connectors, ferrites, etc. An example of the results sheet is shown in table 1.

Table 1: Example of a verification results sheet for the Stripline test facility

Stripline verification procedure results sheet													PAGE 1 of 1											
Stripline reference number:.....							Date:.....						Ambient temperature:.....					Relative humidity:.....						
Freq. (MHz)	Signal Level (dBm)	Direct (dB $\mu$ V)	Measurement Position					Overall Value Position					Theory (dB)	Difference Position					Transform factor (dB) Pos'n 1					
			1	2	3	4	5	1	2	3	4	5		1	2	3	4	5						
Signal generator: Ref. No. SG 001							Receiving device: Ref. No. SA 001																	
Cable: S/No. CA 001							Cable: S/No. CA 002																	
Attenuator: S/No. AT 01							Attenuator: S/No. AT 02																	
Ferrite beads: Type number worry beads							Manufacturer: Rusty co.																	
monopole: Ref. No. MA 001							Adapter: Ref. No. AD 001																	

### 6.3 Verification procedure

Direct attenuation measurement

- 1) The signal generator cable and the receiving device cable should be connected together, via the attenuators and an "in-line" adapter as shown in figure 10. Alternatively, if the use of an adapter is not practical because, for example, the separation between the signal generator and receiver is too great, a calibrated cable may be used instead.

NOTE 1: Use of a cable will increase the overall measurement uncertainty.

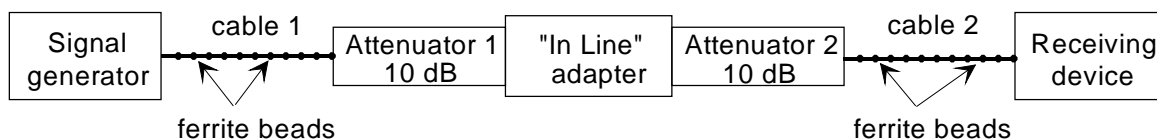

**Figure 10: Initial equipment arrangement for the verification test**

- 2) Adjust the output of the signal generator to an appropriate level. The minimum acceptable level for any frequency in the band may be calculated from:
- 20 dB above the Stripline/monopole attenuator plus the attenuators plus cable losses plus ambient noise.

EXAMPLE:  $20 \text{ dB} + 40 \text{ dB (Stripline/monopole attenuation)} + 20 \text{ dB (attenuators)} + 4 \text{ dB (cable losses)} - 110 \text{ dBm (ambient noise floor)} = -26 \text{ dBm}$ .

If the calculated level is not available across the entire 30 MHz to 150 MHz frequency band then the verification cannot proceed.

The output level from the signal generator (dBm) for all frequencies should be recorded in the results sheet (see table 2) in the column headed "Signal level".

Once set, this signal generator output level should not be readjusted again for the entire duration of the verification procedure.

- 3) The receiving device and signal generator should be tuned to the appropriate frequency, starting at the first frequency given in the results sheet (see table 2). The output level of the signal generator should be checked (to be certain that the original set value has been maintained) and the received level (dB $\mu$ V) on the receiving device should be recorded in the results sheet (see table 2). For each frequency, the value to be entered in the column headed "Direct" on the results sheet is the sum of this received level plus the loss of the "in-line" adapter or cable i.e.:

"Direct" value = received level + loss of "in-line" adapter or cable

- 4) Step 3 should be repeated for all the frequencies in the results sheet (see table 2).

Radiated attenuation through the Stripline

- 5) The monopole should be mounted in position 1 as shown in figure 11.

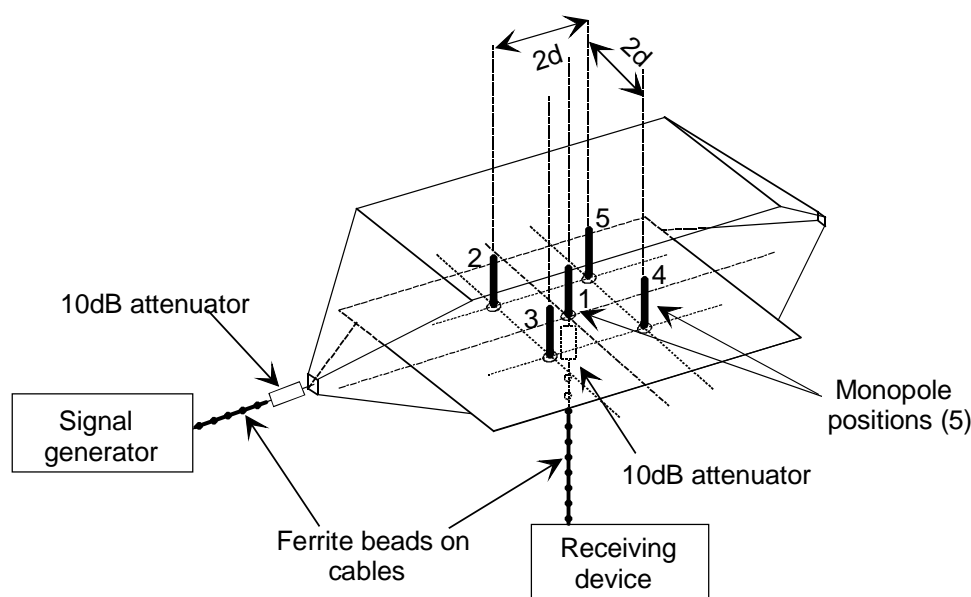

**Figure 11: Schematic of the equipment layout for radiated attenuation through the Stripline**

- 6) The adapter or cable used to make the direct connection between the attenuator pads should be removed and the signal generator cable plus its associated attenuator connected to the input of the Stripline. The receiver cable and its associated attenuator should be connected to the monopole output. Figure 11 shows schematically the set-up.
- 7) The signal generator and receiving device should be tuned to the first frequency in the results sheet (see table 2).

**Table 2: Results sheet for Stripline verification procedure**

Stripline verification procedure results sheet													PAGE 1 of 1								
Stripline reference number:.....						Date:.....															
Ambient temperature:.....						Relative humidity:															
Freq. (MHz)	Signal Level (dBm)	Direct (dBμV)	Measurement Position					Overall Value Position					Theory (dB)	Difference Position					Transform factor (dB) Pos'n 1		
			1	2	3	4	5	1	2	3	4	5		1	2	3	4	5			
30													54,6								
35													54,1								
40													55,4								
45													55,4								
50													48,9								
60													46,3								
70													46,2								
80													46,5								
90													47,4								
100													46,4								
120													45,3								
140													43,7								
150													42,8								
Signal generator:						Receiving device:															
Cable:						Cable:															
Attenuator:						Attenuator:															
Ferrite beads:						Manufacturer:															
monopole:						Adapter:															

- 8) The output level of the signal generator should be checked (to ensure that an inadvertent change to the original set level has not occurred) and the received level on the receiving device (dBμV) should be recorded in the results sheet (see table 2). This value should be entered in the results sheet under the column heading "Measurement" in the relevant "Position" column.
- 9) Step 8 should be repeated for all other frequencies in the results sheet.
- 10) Steps 8 and 9 should be repeated for the other 4 positions of the monopole (as shown in figure 11).

NOTE 2: In figure 11,  $d = 0,2$  m.

## 6.4 Processing the results of the verification procedure

### 6.4.1 Introduction

Having carried out the verification procedure as detailed in clause 6.3, the results sheet should have values filling the first eight column, namely those headed "Freq.", "Signal level", "Direct" and the five position columns under the heading "Measurement" as well as the column headed "Theory". This clause details the values to be incorporated in all the remaining columns.

### 6.4.2 Completing the results sheet

The next columns to be filled in are the five under the heading "Overall Value". In the column headed "Overall Value/Position/1" the values to be entered are the values in the "direct" column minus the corresponding values entered under "Measurement/Position/1". This should be repeated for all other positions under the heading "Overall Value" i.e.:

$$\text{"Overall Value" position } n = \text{"Direct" - "Measurement" position } n \quad (6.1)$$



Then, the "Difference" column should be completed by subtracting the values under the column headed "Overall Value" to those under the heading "Theory" i.e.:

$$\text{"Difference" position } n = \text{"Overall Value" position } n - \text{"Theory" position } n \quad (6.2)$$

NOTE: The values given in table 2 under the heading "Theory" assume 3 important factors. Firstly that the input matching to the Stripline is strictly in accordance with EN 55020 [4] (i.e. it comprises  $2 \times 122,4 \Omega$  and  $1 \times 122,5 \Omega$  resistors), secondly that the Stripline is terminated with a  $150 \Omega$  resistor and thirdly no matching is attempted on the monopole input.

Finally, the column headed "transform factor, dB" should be filled in. To perform the calculation, the values for the antenna factor of the monopole are required. These are supplied in table 3. The values to be entered in the results sheet are all calculated for position 1 of the monopole and should be derived as follows:

$$\begin{aligned} \text{transform factor, (dB)} &= \text{"Measurement" position 1} \\ &+ \text{signal generator cable loss (dB)} \\ &+ \text{signal generator attenuator loss (dB)} \\ &+ \text{antenna factor of the monopole (dB)} \\ &+ \text{monopole attenuator loss (dB)} \\ &+ \text{receiver cable loss (dB)} \\ &+ \text{signal generator output level (dBm)}. \end{aligned}$$

**Table 3: Antenna factor of the monopole**

Frequency (MHz)	Antenna factor (dB/m)
30	50,3
35	49,7
40	49,0
45	48,4
50	47,8
60	46,5
70	45,2
80	43,9
90	42,7
100	41,4
120	38,8
140	36,3
150	35,0

## 6.5 Report Format

It is suggested that the results of the Stripline verification be in the form of a completed results sheet.

## 6.6 Calculation of measurement uncertainty

The verification procedure involves two different stages, the first stage, by measuring the reference, direct attenuation through the cables, attenuators, etc., involved in both stages of the procedure, sets a reference level against which the path loss from the Stripline input to monopole output is compared in the second stage.

A fully worked example calculation of the uncertainty associated with this verification procedure can be found in TR 102 273-1-2 [6], clause 5.

The magnitude of the random uncertainty contribution to each stage of the procedure can be assessed from multiple repetition of the respective measurements.

### 6.6.1 Uncertainty contribution: Stage 1: Reference, direct attenuation measurement

The first stage (the reference, direct attenuation measurement) is made with all the items of test equipment connected directly together via an adapter (alternatively a coaxial cable) between the two attenuators as shown in figure 12.

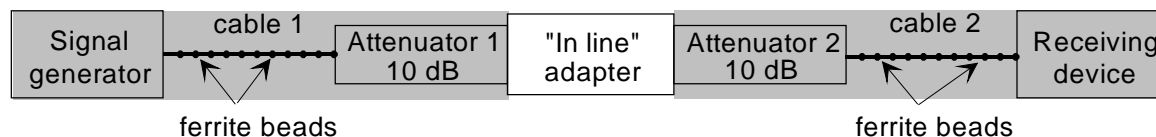

NOTE: In figure 12, components common to both stages of the test are shaded.

**Figure 12: Stage 1: Reference, direct attenuation measurement**

Despite the commonality of most of the components to both stages of this procedure, the mismatch uncertainty contribution from both stages of the test has to be calculated and included in the overall uncertainty calculations, since the load conditions vary i.e. the Stripline input and monopole output replace the adapter in the second stage. However, the commonality of most of the components does lead to most of their individual uncertainty contributions cancelling (e.g. the uncertainty associated with the insertion loss of a cable, etc.).

Table 4 lists all the individual uncertainty contributions associated with this stage of the procedure. Annex A should be consulted for the sources and/or magnitudes of the uncertainty contributions.

**Table 4: Contributions from the reference, direct attenuation measurement**

$u_{j \text{ or } i}$	Description of uncertainty contributions	dB
$u_{j35}$	mismatch: direct attenuation measurement	
$u_{j38}$	signal generator: absolute output level	
$u_{j39}$	signal generator: output level stability	
$u_{j19}$	cable factor: signal generator	0,00
$u_{j19}$	cable factor: receiving device	0,00
$u_{j41}$	insertion loss: signal generator cable	0,00
$u_{j41}$	insertion loss: receiving device cable	0,00
$u_{j40}$	insertion loss: signal generator attenuator	0,00
$u_{j40}$	insertion loss: receiving device attenuator	0,00
$u_{j42}$	insertion loss: adapter (alternatively coaxial cable)	
$u_{j47}$	receiving device: absolute level	0,00
$u_{j48}$	receiving device: linearity	0,00
$u_{j01}$	random uncertainty (see note in clause A.18 of TR 102 273-1-2 and note in clause 6.4.7 of TR 102 273-1-1)	

The standard uncertainties from table 4 should be combined by RSS in accordance with TR 102 273-1-1 [5], clause 5. This gives the combined standard uncertainty,  $u_{c \text{ direct attenuation measurement}}$  for the reference measurement in dB.

### 6.6.2 Uncertainty contribution: Stage 2: Stripline attenuation measurement

The second stage of the procedure involves disconnecting the adapter and connecting the cables to the Stripline input and monopole output ports. The equipment set-up is shown schematically in figure 13.

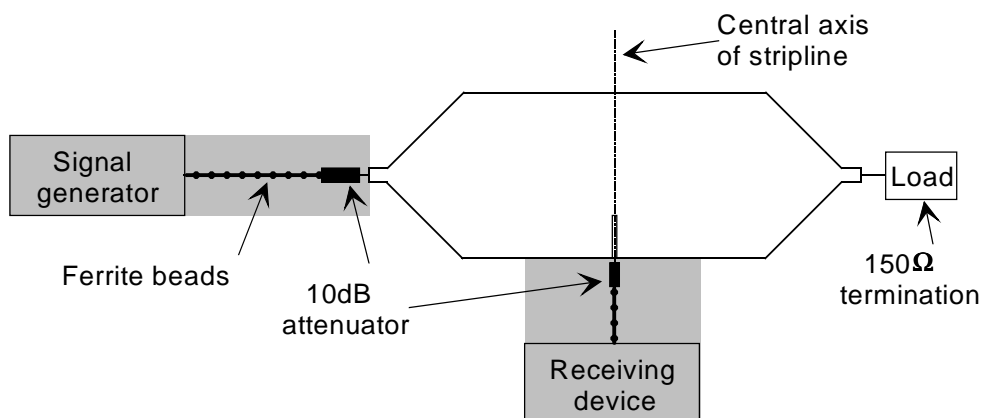

NOTE: In figure 13, components common to both stages of the test are shaded.

**Figure 13: Stripline attenuation measurement test equipment set-up**

The difference in received signal levels for the same input power from the signal generator reveals the loss through the Stripline, from which the transform factor is derived.

Table 5 lists all the individual uncertainty contributions associated with this stage of the procedure. Annex A should be consulted for the sources and/or magnitudes of the uncertainty contributions.

**Table 5: Contributions from the Stripline attenuation measurement**

$u_{j \text{ or } i}$	Description of uncertainty contributions	dB
$u_{\beta 36}$	mismatch: transmitting part	
$u_{\beta 37}$	mismatch: receiving part	
$u_{\beta 38}$	signal generator: absolute output level	
$u_{\beta 39}$	signal generator: output level stability	
$u_{j19}$	cable factor: signal generator	0,00
$u_{j19}$	cable factor: receiving device	0,00
$u_{j41}$	insertion loss: signal generator cable	0,00
$u_{j41}$	insertion loss: receiving device cable	0,00
$u_{j40}$	insertion loss: signal generator attenuator	0,00
$u_{j40}$	insertion loss: receiving device attenuator	0,00
$u_{\beta 31}$	Stripline: antenna factor of the monopole	
$u_{\beta 34}$	ambient effect	
$u_{\beta 33}$	Stripline: influence of site effects	
$u_{j47}$	receiving device: absolute level	
$u_{j48}$	receiving device: linearity	
$u_{01}$	random uncertainty (see note in clause A.18 of TR 102 273-1-2 and note in clause 6.4.7 of TR 102 273-1-1)	

The standard uncertainties from table 5 should be combined by RSS in accordance with TR 102 273-1-1 [5], clause 5. This gives the combined standard uncertainty,  $u_c$  Stripline attenuation measurement, for the Stripline attenuation measurement in dB.

### 6.6.3 Expanded uncertainty of the verification procedure

The combined standard uncertainty of the results of the Stripline verification procedure is the RSS combination of the components outlined above in clauses 6.6.1 and 6.6.2. The components to be combined are  $u_c$  direct attenuation measurement and  $u_c$  Stripline attenuation measurement

$$u_c = \sqrt{u_c \text{ direct attenuation measurement}^2 + u_c \text{ Stripline attenuation measurement}^2} = \dots \text{dB} \quad (6.3)$$

The expanded uncertainty is  $\pm 1,96 \times u_c = \text{---,---dB}$  at 95 % confidence level.

## 7 Test methods

### 7.1 Introduction

The following test methods apply to integral antenna devices only i.e. EUTs not fitted with either a permanent or a temporary external antenna connector.

The Stripline to be used is that detailed in EN 55020 [4].

The size of a Stripline limits the usable frequency range. To avoid the possibility of generating unwanted field modes (which can disturb the required electric field distribution in the line), the spacing between the plates should not exceed  $\lambda/2$ . The two-plate Stripline detailed in EN 55020 [4] has a plate spacing of 0,8 m and, consequently, an upper frequency limit of 150 MHz.

Given the further recommendation that, for best accuracy (i.e. closest approximation to a plane wave within the Stripline), an EUT should not measure more than a third of the plate separation, the overall maximum size of EUT which can be accurately tested is dictated as 0,27 m.

This size restriction only applies to the vertical dimension within the Stripline, but it is a significant limitation since this is also the direction in which the electric vector points, as shown in figure 14. No other dimension of the EUT should exceed  $\lambda/2$ . These size limitations therefore severely restrict the use of a Stripline. Where larger size EUTs are tested (up to a maximum size in the E-plane of 0,7 m), correction factors need to be applied to the results and significantly greater measurement uncertainty is involved.

#### 7.1.1 Site preparation

The Stripline should be placed on non conducting supports at least 0,8 m above the floor and not closer than 0,8 m to the ceiling. When used inside a room (whether screened or not), continuous lines of vertical panels covered in absorbing material should be placed between the open sides of the Stripline and the walls. The absorbing material should provide an adequate level of absorption (typically 15 dB minimum reflectivity at the frequency of test).

At the start of each day, system checks should be made on the Stripline. The following two procedures, as a minimum requirement, should be carried out.

- 1) All items of test equipment requiring electrical supplies should be connected to their power sources, switched on and allowed adequate time to stabilize, as recommended by the manufacturers. Where a stabilization period is not given by the manufacturer, 30 minutes should be allowed. After this time period, those items of test equipment which possess the facility should have their self test/self calibration procedures performed.

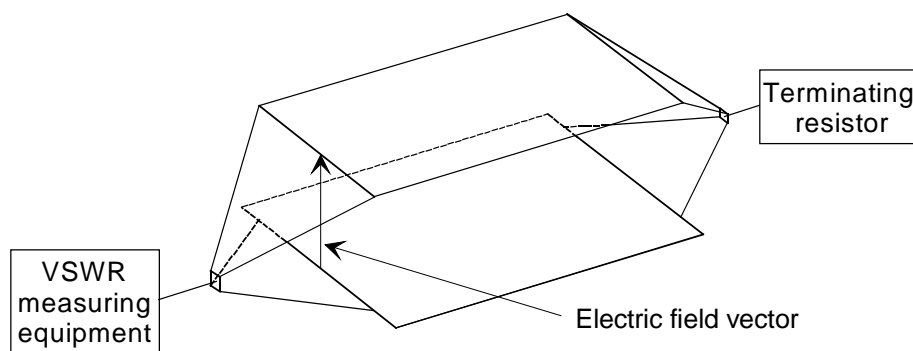

**Figure 14: Stripline test facility set-up for daily checking**

- 2) A VSWR measurement (using for example, a network analyser) should be made on the input to the Stripline, using any necessary coaxial cables and adapters, with the far end of the Stripline terminated in a load (a 150  $\Omega$  resistor soldered between the output terminals), as shown in figure 14. No attenuators should be connected between the measuring equipment and the Stripline input. The measurement should cover the full band (30 MHz to 150 MHz). The VSWR measurement should be compared with previous tests and any anomalies investigated.

## 7.1.2 Preparation of the EUT

The manufacturer should supply information about the EUT covering the operating frequency, polarization, supply voltage(s) and the reference face. Additional information, specific to the type of EUT should include, where relevant, carrier power, channel spacing, whether different operating modes are available (e.g. high and low power modes) and if operation is continuous or is subject to a maximum test duty cycle (e.g. 1 minute on, 4 minutes off).

Where necessary, a mounting bracket or support of minimal size should be available for mounting the EUT. This bracket should be made from low conductivity, low relative dielectric constant (i.e. less than 1,5) material(s) such as expanded polystyrene, balsawood, etc.

A block of non-conducting, low dielectric constant (less than 1,5) material should be available, on which the EUT and its bracket can be mounted within the Stripline, so that its volume centre is midway between the plates.

All RF cables used during the test should be dressed with ferrite beads, spaced at 0,15 m intervals, for their entire lengths. They should be routed directly away from the Stripline - the feed cable from the signal generator should be along the line of the Stripline's axis, whilst, during the field measurement part of the test (if carried out), the cable from the monopole to the receiving device should be at right angles to this axis.

## 7.1.3 Power supplies to the EUT

The presence of power cables within the Stripline can effect the measured performance of the EUT. For this reason, attempts should be made to make them "transparent" as far as the testing is concerned. All tests should be performed using power supplies wherever possible, including tests on EUTs designed for battery-only use.

In all cases, power leads should be connected to the EUT's supply terminals (and monitored with a digital voltmeter) but the battery should remain present, electrically isolated from the rest of the EUT, possibly by putting tape over its contacts.

## 7.2 Transmitter tests

### 7.2.1 Frequency error

This test is not usually performed in a Stripline and is therefore not considered here.

### 7.2.2 Effective radiated power

This test is not usually performed in a Stripline and is therefore not considered here.

### 7.2.3 Spurious emissions

This test is not usually performed in a Stripline and is therefore not considered here.

### 7.2.4 Adjacent channel power

This test is not usually performed in a Stripline and is therefore not considered here.

## 7.3 Receiver tests

### 7.3.1 Sensitivity tests (30 MHz to 1 000 MHz)

The test method for measuring the maximum (or average) usable sensitivity of a receiver is in two parts. In the first part of the test, the minimum (or average) output level from the signal generator which produces the required response from the EUT is found. In the second part, the field strength corresponding to this minimum (or average) output level from the signal generator is determined.

The field strength in the Stripline can be determined in several ways. If the results of the verification procedure are still valid (i.e. if the facility has not been damaged, moved or had its immediate environment changed since the verification procedure was carried out), then the input power to the Stripline can be directly related to the field strength using the transform factor derived during that procedure. Alternatively, the field strength can be measured during the test by using either a monopole or a three-axis probe.

The receiver output depends on the type of information the receiver has been designed to demodulate. There are principally 3 different types of information: analogue speech, bit stream and messages.

#### Definition

For analogue speech:

- the **maximum usable sensitivity** expressed as field strength is the minimum of 8 field strength (in dB $\mu$ V/m) measurements (at 45° increments in the horizontal plane) at the nominal frequency of the receiver and with specified test modulation, which produce a SINAD ratio of 20 dB measured at the receiver input through a telephone psophometric weighting network. The starting horizontal angle is the reference orientation as stated by the manufacturer.
- the **average usable sensitivity** expressed as field strength is the average of 8 field strength (in dB $\mu$ V/m) measurements (at 45° increments in the horizontal plane) at the nominal frequency of the receiver and with specified test modulation, which produce a SINAD ratio of 20 dB measured at the receiver input through a telephone psophometric weighting network. The starting horizontal angle is the reference orientation as stated by the manufacturer.

For bit stream:

- the **maximum usable sensitivity** expressed as field strength is the minimum of 8 field strength (in dB $\mu$ V/m) measurements (at 45° increments in the horizontal plane) at the nominal frequency of the receiver and with specified test modulation, which produces, after demodulation, a data signal with a bit error ratio of  $10^{-2}$  measured at the receiver input. The starting horizontal angle is the reference orientation as stated by the manufacturer.
- the **average usable sensitivity** expressed as field strength is the average of 8 field strength (in dB $\mu$ V/m) measurements (at 45° increments in the horizontal plane) at the nominal frequency of the receiver and with specified test modulation, which produce, after demodulation, a data signal with a bit error ratio of  $10^{-2}$  measured at the receiver input. The starting horizontal angle is the reference orientation as stated by the manufacturer.

For messages:

- the **maximum usable sensitivity** expressed as field strength is the minimum of 8 field strength (in dB $\mu$ V/m) measurements (at 45° increments in the horizontal plane) at the nominal frequency of the receiver and with specified test modulation, which produces, after demodulation, a message acceptance ratio of 80 % measured at the receiver input. The starting horizontal angle is with the reference orientation as stated by the manufacturer.
- the **average usable sensitivity** expressed as field strength is the average of 8 field strength (in dB $\mu$ V/m) measurements (at 45° increments in the horizontal plane) at the nominal frequency of the receiver and with specified test modulation, which produce, after demodulation, a message acceptance ratio of 80 % measured at the receiver input. The starting horizontal angle is the reference orientation as stated by the manufacturer.

### 7.3.1.1 Apparatus required

- digital voltmeter;
- ferrite beads;
- 10 dB attenuators;
- power supply;
- connecting cables;
- Stripline test facility;
- RF signal generator;
- receiving device (measuring receiver or spectrum analyser);
- monopole or three-axis probe.

NOTE: The receiving device and monopole (or three-axis probe) are only required if the results of the verification procedure are not used to determine the field strength within the Stripline.

Additional requirements for analogue speech:

- AF source;
- SINAD meter (incorporating telephone psophometric weighting network);
- acoustic coupler (alternatively: audio load).

Additional requirements for bit stream:

- bit stream generator;
- bit error measuring test set.

Additional requirements for messages:

- acoustic coupler;
- message generator;
- response measuring test set.

The types and serial numbers of all items of test equipment should be recorded on page 1 of the log book results sheet (see table 8).

### 7.3.1.2 Method of measurement

- 1) The EUT should be placed on a non-conducting support constructed from low dielectric constant (i.e. less than 1,5) material(s) so that its volume centre lies midway between the plates and directly above the central hole (drilled for the purposes of the verification procedure) in the bottom plate. It should be mounted in the position closest to its normal use as declared by the manufacturer (consistent with the polarization within the Stripline) with its reference face oriented towards the input (source end) of the Stripline (this is the 0° reference angle for the test). This orientation and mounting configuration should be recorded on page 1 of the log book results sheet (see table 8).
- 2) The electrical supply and monitoring cables should be routed straight down towards the bottom plate and out through the central hole.

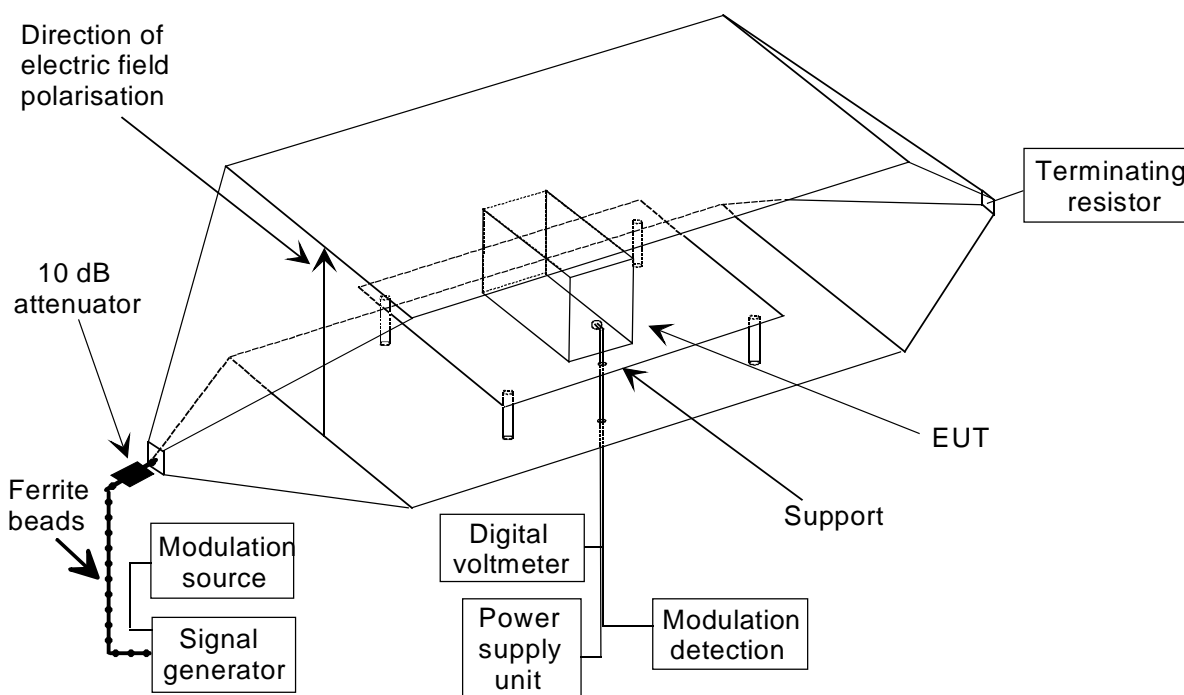

**Figure 15: Test equipment layout for maximum and average usable sensitivity tests**

For analogue speech:

- 3a) The signal generator should be connected to the input of the Stripline via a 10 dB attenuator and a calibrated, ferrited coaxial cable. Its output should be modulated by test modulation AM-1 (produced by the AF source). The signal generator should be tuned to the nominal frequency of the EUT.
- 3b) The EUT should be connected to the modulation detector (a SINAD meter incorporating a telephone psophometric weighting network) through an AF load or by an acoustic coupler for equipment not fitted with a direct connection. See figure 15.
- 3c) The output level of the signal generator should be adjusted until a psophometrically weighted SINAD ratio of 20 dB is obtained from the EUT. The corresponding output power level from the signal generator (dBm) should be recorded on page 2 of the log book results sheet (see table 8).
- 3d) The EUT should be successively rotated through 45° in the horizontal plane to new testing angles of 45°, 90°, 135°, 180°, 225°, 270° and 315° (thereby covering the entire 360° in eight measurements). At each angle, Step 3c should be repeated.
- 3e) For the maximum sensitivity test only, after the final measurement, the eight values of signal generator output power level should be compared and the lowest value entered on page 2 of the log book results sheet (see table 8).
- 3f) For the average sensitivity test only, after the final measurement, the eight values of signal generator output power level should be averaged and the resulting value entered on page 2 of the log book results sheet (see table 8).

NOTE 1: Each of the output power levels in dBm should be converted into  $\mu\text{V}$  before averaging. Having found the average value in  $\mu\text{V}$ , this should then be converted back into dBm. These conversions should be calculated as follows:

$$\text{a) dBm into } \mu\text{V: } \mu V_i = 10^{\left(\frac{107 - dBm_i}{20}\right)};$$

$$\text{b) Average voltage } (\mu\text{V}) = \frac{\sum_{i=1}^{i=8} \mu V_i}{8};$$



$$c) \text{ Average output power level (dBm)} = 20 \log_{10} (\text{Average voltage } \mu\text{V}) - 107.$$

3g) The procedure should now resume with the field measurement stage (Step 4).

For bit stream:

- 3a) The signal generator should be connected to the input of the Stripline via a 10 dB attenuator and a calibrated, ferrited coaxial cable. Its output should be modulated by test modulation DM-2 (produced by the bit stream generator). The signal generator should be tuned to the nominal frequency of the EUT.
- 3b) The EUT should be directly connected to the modulation detector (a bit error measuring test set, which should also receive a direct input from the bit stream generator), (see figure 15).
- 3c) The output level of the signal generator should be adjusted until a bit error ratio of  $10^{-2}$  is obtained from the EUT. The corresponding output power level (dBm) from the signal generator should be recorded on page 2 of the log book results sheet (see table 8).
- 3d) The EUT should be successively rotated through  $45^\circ$  in the horizontal plane to new testing angles of  $45^\circ$ ,  $90^\circ$ ,  $135^\circ$ ,  $180^\circ$ ,  $225^\circ$ ,  $270^\circ$  and  $315^\circ$  (thereby covering the entire  $360^\circ$  in eight measurements). At each angle, Step 3c should be repeated.
- 3e) For the maximum sensitivity test only, after the final measurement, the eight values of signal generator output power level should be compared and the lowest value entered on page 2 of the log book results sheet (see table 8).
- 3f) For the average sensitivity test only, after the final measurement, the eight values of signal generator output power level should be averaged and the resulting value entered on page 2 of the log book results sheet (see table 8).

NOTE 2: Each of the output power levels in dBm should be converted into  $\mu\text{V}$  before averaging. Having found the average value in  $\mu\text{V}$ , this should then be converted back into dBm. These conversions should be calculated as follows:

$$a) \text{ dBm into } \mu\text{V: } \mu V_i = 10^{\left(\frac{107 - dBm_i}{20}\right)};$$

$$b) \text{ Average voltage } (\mu\text{V}) = \frac{\sum_{i=1}^{i=8} \mu V_i}{8};$$

$$c) \text{ Average output power level (dBm)} = 20 \log_{10} (\text{Average voltage } \mu\text{V}) - 107.$$

3g) The procedure should now resume with the field measurement stage (Step 4).

For messages:

- 3a) The signal generator should be connected to the input of the Stripline via a 10 dB attenuator and a calibrated, ferrited coaxial cable. Its output should be modulated by test modulation DM-3 (produced by the message generator). The signal generator should be tuned to the nominal frequency of the EUT.
- 3b) The EUT should be connected to the modulation detector (a response measuring test set) via an acoustic coupler (pipe) which is made from low dielectric constant (i.e. less than 1,5) material(s), (see figure 15).
- 3c) The output level of the signal generator should be adjusted until a message acceptance ratio of less than 10 % is obtained from the EUT.
- 3d) The test message should be transmitted repeatedly, whilst observing for each message whether a successful response is obtained. The output level of the signal generator should be increased by 2 dB for each occasion that a successful response is NOT obtained.
- 3e) Step 3d should be repeated until three consecutive successful responses are observed at the same output level from the signal generator. The output power level from the signal generator (dBm) should be recorded on page 2 of the log book results sheet (see table 8).

- 3f) The output signal level from the signal generator should be reduced by 1 dB. The new signal power level (dBm) should be recorded on page 2 of the log book results sheet (see table 8) and the response of the EUT observed.
- 3g) If a successful response is NOT obtained, the output signal level should be increased by 1 dB and the new level recorded in the results sheet. If a successful response IS obtained, the input level should not be changed until three consecutive successful responses have been observed. In this case, the output signal level from the signal generator should be reduced by 1 dB and the new level recorded in the results sheet. No signal levels should be recorded unless preceded by a change of level.
- 3h) Step 3g should be repeated until a total of 10 recorded values for the signal generator output power level (dBm) have been entered on page 2 of the log book results sheet (see table 8).
- 3i) The EUT should be successively rotated through 45° in the horizontal plane to new testing angles of 45°, 90°, 135°, 180°, 225°, 270°, 315° (thereby covering the entire 360° in eight measurements). At each angle Steps 3c to 3h should be repeated.
- 3j) For each angle, the 10 recorded values of the signal generator output power level should be averaged, by firstly converting them into  $\mu\text{V}$ , secondly averaging in  $\mu\text{V}$  (and recording the eight average values on page 2 of the log book results sheet (see table 8)) and finally converting the 8 values back into dBm, again recording these values on page 2 of the log book results sheet (see table 8).

NOTE 3: The various conversions should be carried out according to the following formulae:

$$\text{a) dBm into } \mu\text{V: } \mu V_i = 10^{\left(\frac{107 - \text{dBm}_i}{20}\right)};$$

$$\text{b) Average voltage } (\mu\text{V}) = \frac{\sum_{i=1}^{i=10} \mu V_i}{10};$$

$$\text{c) Average output power level (dBm) = } 20 \log_{10} (\text{Average voltage } \mu\text{V}) - 107.$$

- 3k) For the maximum sensitivity test only, the eight average values derived in Step 3j should be compared and the lowest value entered on page 2 of the log book results sheet (see table 8).
- 3l) For the average sensitivity test only, the eight average values in  $\mu\text{V}$  derived in Step 3j should themselves be averaged, the new average value converted into dBm and the resulting value entered on page 2 of the log book results sheet (see table 8).

NOTE 4: The conversion should be calculated as follows:

$$\text{Power level (dBm) = } 20 \log_{10} (\text{Average voltage } \mu\text{V}) - 107.$$

3m) The procedure should now continue with the field measurement stage (Step 4).

**Field measurement:** For Stripline test facilities which, since the verification was carried out:

- show no visual sign of change (i.e. no damaged components or plates);
  - and have not been moved;
  - and have not had their surrounding environment (i.e. the layout of the absorbing panels and test equipment) changed;
  - the test is concluded at this point since the transform factors determined during the verification procedure can be used for determining the field strength.
  - If any, or all of these conditions are not satisfied, the field strength should be measured directly by using either a monopole or a three-axis probe (isotropic monitor). Performing Steps 6 to 9 for the monopole or Steps 10 and 11 for the three-axis probe gives measured values of field strength at the precise frequency of test - thereby eliminating the need for interpolation of the transform factor (and its associated uncertainty) between the frequencies at which the verification procedure was carried out, if the results of that procedure are used.
- 4) The modulation source should be removed from the signal generator, leaving an unmodulated carrier.

5) The output power level of the signal generator should be set as follows:

**For the maximum sensitivity test:** at the lowest value recorded on page 2 of the log book results sheet (see table 8) for the relevant modulation.

**For the average sensitivity test:** at the average value recorded on page 2 of the log book results sheet (see table 8) for the relevant modulation.

Monopole only : Steps 6 to 9

- 6) The EUT and non-conducting support plate should be removed from the Stripline and replaced by the monopole. The monopole should be mounted through the central hole in the bottom plate. The monopole should have a length, when installed, of  $0,2 \pm 0,002$  m above the bottom plate. Its diameter should be a maximum of 0,002 m and it should be straight to within  $\pm 0,002$  m.
- 7) The monopole should be connected via any adapters that are necessary, through a 10 dB attenuator and a calibrated, ferrited coaxial cable to the receiving device.
- 8) The received level appearing on the receiving device should be recorded (dB $\mu$ V) on page 2 of the log book results sheet (see table 8).
- 9) The monopole should be removed from the Stripline and replaced by the EUT which should again be mounted on a non-conducting support with its volume centre directly over the central hole in the bottom plate. Whilst the EUT should again have its reference face oriented towards the input, it should, for this part of the procedure, be placed on its side so that the polarization of the Stripline is orthogonal to it. This mounting configuration should be recorded on page 1 of the log book results sheet (see table 8) and **Steps 2 to 8** repeated.

NOTE 5: In Step 3d for analogue speech and bit stream modulations (Step 3i for messages) the rotation should now be in the vertical plane i.e. about a horizontal axis.

three-axis probe only : Steps 10 and 11

- 10) The **three**-axis probe should be oriented as shown in figure 16 with the centre of its cubic head at the intersection of the centre lines of the Stripline. A mounting block of low dielectric constant (i.e. less than 1,5) material e.g. expanded polystyrene, balsawood, etc., should be used to position the probe accurately. The electric field strength value for the vertical direction only (i.e. the z direction in figure 16) should be recorded (dB $\mu$ V/m) on page 2 of the log book results sheet (see table 8).
- 11) The **three**-axis probe should be removed from the Stripline and replaced by the EUT which should again be mounted on a non-conducting support with its volume centre directly over the central hole drilled in the bottom plate. Whilst the EUT should again have its reference face oriented towards the source end, it should, for this part of the procedure, be placed on its side so that the polarization of the Stripline is orthogonal to it. This mounting configuration should be recorded on page 1 of the log book results sheet (see table 8) and **Steps 2 to 5 and 10** repeated.

NOTE 6: In Step 3d for analogue speech and bit stream modulations (Step 3i for messages) the rotation should now be in the vertical plane i.e. about a horizontal axis.

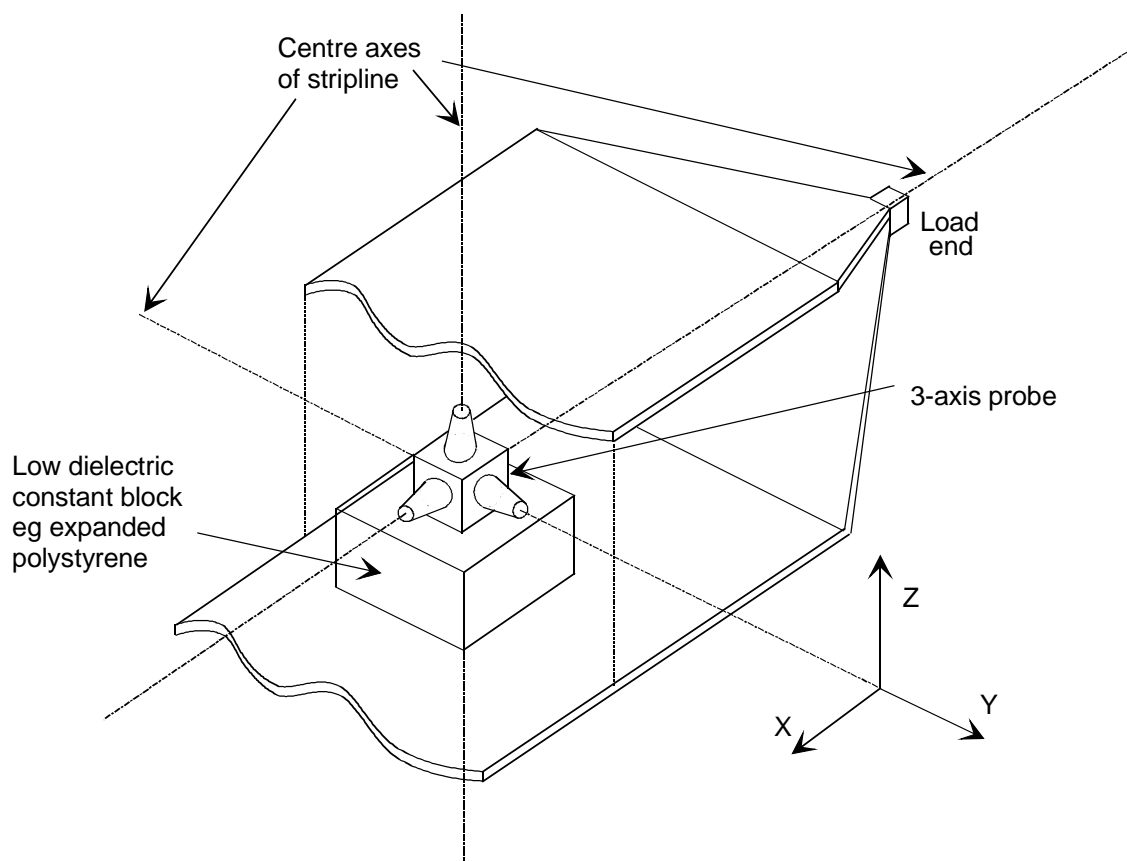

**Figure 16: Location of the three-axis probe at the intersection of the Stripline's centre axes**

### 7.3.1.3 Procedure for the completion of the results sheets

There are two values that need to be derived before the overall results sheet (see table 9) can be completed. These are the values for the maximum (or average) usable sensitivity of the EUT and the expanded measurement uncertainty.

**NOTE:** Guidance for deriving the values of the various parameters used in the following calculations is given in table 6.

For field measurement using the results of the verification procedure only

The verification procedure provides values for the transform factor of the Stripline i.e. the relationship between the input power (in dBm) and the resulting electric field strength (in dB $\mu$ V/m) between the plates. To relate the field strength to a particular setting of the signal generator, the following calculation is performed:

$$\text{Field strength (dB}\mu\text{V/m)} = \text{Signal generator output power (dBm)} - \text{signal generator cable loss (dB)} - \text{signal generator attenuator loss (dB)} + \text{transform factor (dB)}$$

The value of field strength resulting from the minimum (or average) output from the signal generator, should be entered on page 2 of the log book results sheet (see table 8).

This value of field strength needs to be corrected for the systematic offsets involved. The overall correction factor for this value of field strength concerns only one term, namely that for the size of the EUT. Various values for different sizes of EUT are given in table 6 and the relevant value should be recorded on page 2 of the log book results sheet (see table 8).

The maximum or average sensitivity for the EUT should be derived as follows:

$$\begin{aligned} \text{Maximum or average usable sensitivity (dB}\mu\text{V/m)} = & \text{Field strength (dB}\mu\text{V/m)} \\ & + \text{overall correction factor (dB)} \end{aligned}$$

and finally, the resulting sensitivity value should be converted into  $\mu\text{V}/\text{m}$  and recorded in the overall results sheet (see table 9). To complete the overall results sheet, the expanded uncertainty for the measurement should be calculated in accordance with clause 7.3.2.

**Table 6: Guidance for deriving correction factors**

<b>Figures for correction factors</b>	
Signal generator cable loss	Obtained directly from the calibration data
Signal generator attenuator loss	Obtained from manufacturer's data
Monopole cable loss	Obtained directly from the calibration data
Monopole attenuator loss	Obtained from manufacturer's data
Transform factor of Stripline	(at the nominal frequency of test): If the verification procedure results were used, the value should be interpolated between the closest set values (unless the test coincides with a set frequency). If a monopole was used during the sensitivity test then the value is as calculated. If a three-axis probe was used during the sensitivity test then the value is zero
Correction factor for size of the EUT	(for the height in the E-plane) (EN 55020 [4]): height $\leq 0,2$ m, correction factor is 1,6 dB 0,2 m < height $\leq 0,4$ m, correction factor is 4,6 dB 0,4 m < height $\leq 0,7$ m, correction factor is 6,0 dB

For field measurement using the monopole only:

The monopole is only used if the results of the verification procedure cannot be relied on (i.e. the Stripline has been moved, damaged, modified, etc., or has had its surroundings changed). In this case, it is necessary to calculate the field strength using the values of received signal level and monopole antenna factor (given in table 7). This is achieved by using the following formula:

$$\begin{aligned} \text{Field strength (dB}\mu\text{V/m)} &= \text{Received signal level (dB}\mu\text{V)} \\ &+ \text{monopole cable loss (dB)} \\ &+ \text{monopole attenuator loss (dB)} \\ &+ \text{Antenna factor (dB/m)} \end{aligned}$$

Where the frequency of test does not coincide with a spot value in table 7, the antenna factor should be deduced by linear interpolation between the closest two frequencies.

**Table 7: Antenna factor of the monopole**

<b>Frequency (MHz)</b>	<b>Antenna factor (dB/m)</b>
30	50,3
35	49,7
40	49,0
45	48,4
50	47,8
60	46,5
70	45,2
80	43,9
90	42,7
100	41,4
120	38,8
140	36,3
150	35,0

This value of field strength needs to be corrected for the systematic offsets involved. The overall correction factor for this value of field strength concerns only one term (for the size of the EUT) since all other systematic offsets are included in the calculation of field strength. Various values for different sizes of EUT are given in table 6 and the relevant value should be recorded on page 2 of the log book results sheet (see table 8).

The maximum or average sensitivity for the EUT should be derived as follows:

Maximum or average usable sensitivity (dB $\mu$ V/m) = Field strength (dB $\mu$ V/m) + overall correction factor (dB) (7.1)

and finally, the sensitivity value should be converted into  $\mu$ V/m and recorded in the overall results sheet (see table 9). To complete the overall results sheet, the expanded uncertainty for the measurement should be calculated in accordance with clause 7.3.2.

For field measurement using the three-axis probe only

In a similar manner to the monopole, the **three**-axis probe is only used when the results of the Stripline verification procedure cannot be relied upon or reduced uncertainty is required.

The three-axis probe directly measures the electric field strength in dB $\mu$ V/m, so the only processing of the measured value is to correct for the size of the EUT. Various values for different sizes of EUT are given in table 6 and the relevant value should be recorded on page 2 of the log book results sheet (see table 8).

The maximum or average sensitivity for the EUT should be derived as follows:

Maximum or average usable sensitivity (dB $\mu$ V/m) = Field strength (dB $\mu$ V/m) + overall correction factor (dB) (7.2)

and finally, the sensitivity value should be converted into  $\mu$ V/m and recorded in the overall results sheet (see table 9). To complete the overall results sheet, the expanded uncertainty for the measurement should be calculated in accordance with clause 7.3.2.

## 7.3.1.4 Log book entries

Table 8: Log book results sheet

RECEIVER SENSITIVITY		Date:	PAGE 1 of 2	
Temperature:.....°C		Humidity:.....%		Frequency:.....MHz
Manufacturer of EUT:.....		Type No:.....		Serial No:.....
Test equipment item	Type No.	Serial No.	VSWR	Insertion loss
Signal generator cable				
Signal generator attenuator				
Monopole cable (if applicable)				
Monopole attenuator (if applicable)				
Ferrite beads			N/A	N/A
Receiving device				N/A
Signal generator				N/A
Digital voltmeter			N/A	N/A
Power supply			N/A	N/A
AF source (if applicable)			N/A	N/A
SINAD meter (if applicable)			N/A	N/A
Audio load (if applicable)			N/A	N/A
Bit stream generator (if applicable)			N/A	N/A
Bit error measuring test set (if applicable)			N/A	N/A
Acoustic coupler (if applicable)			N/A	N/A
Message generator (if applicable)			N/A	N/A
Response measuring test set (if applicable)			N/A	N/A
Monopole (if applicable)				N/A
three-axis probe (if applicable)			N/A	N/A
<b>Vertical polarization</b> Mounting configuration of EUT		<b>Horizontal polarization</b> Mounting configuration of EUT		

RECEIVER SENSITIVITY (analogue speech)									Date: PAGE 2 of 2									
Vertical polarization									Horizontal polarization									
Signal generator level (dBm) against angle for 20 dB SINAD									Signal generator level (dBm) against angle for 20 dB SINAD									
	0°	45°	90°	135°	180°	225°	270°	325°		0°	45°	90°	135°	180°	225°	270°	325°	
level									level									
LOWEST of the 8 levels above									LOWEST of the 8 levels above									
AVERAGE of the 8 levels above									AVERAGE of the 8 levels above									
<b>For monopole:</b> Received sig. level on receiving device:.....dB $\mu$ V									<b>For monopole:</b> Received sig. level on receiving device:.....dB $\mu$ V									
<b>For three-axis probe:</b> Field strength in vertical plane:.....dB $\mu$ V/m									<b>For three-axis probe:</b> Field strength in vertical plane:.....dB $\mu$ V/m									
Calculated field strength:.....dB $\mu$ V/m									Calculated field strength:.....dB $\mu$ V/m									
Correction factors																		
Signal generator cable loss									Signal generator cable loss									
Signal generator attenuator loss									Signal generator attenuator loss									
Monopole cable loss									Monopole cable loss									
Monopole attenuator loss									Monopole attenuator loss									
Transform factor of Stripline									Transform factor of Stripline									
Correction factor for size of the EUT									Correction factor for size of the EUT									
Overall measurement correction									Overall measurement correction									

RECEIVER SENSITIVITY (bit stream)									Date: PAGE 2 of 2									
Vertical polarization									Horizontal polarization									
Signal generator level (dBm) against angle for 10 <sup>-2</sup> BER									Signal generator level (dBm) against angle for 10 <sup>-2</sup> BER									
	0°	45°	90°	135°	180°	225°	270°	325°		0°	45°	90°	135°	180°	225°	270°	325°	
level									level									
LOWEST of the 8 levels above									LOWEST of the 8 levels above									
AVERAGE of the 8 levels above									AVERAGE of the 8 levels above									
<b>For monopole:</b> Received sig. level on receiving device:.....dB $\mu$ V									<b>For monopole:</b> Received sig. level on receiving device:.....dB $\mu$ V									
<b>For three-axis probe:</b> Field strength in vertical plane:.....dB $\mu$ V/m									<b>For three-axis probe:</b> Field strength in vertical plane:.....dB $\mu$ V/m									
Calculated field strength:.....dB $\mu$ V/m									Calculated field strength:.....dB $\mu$ V/m									
Correction factors																		
<b>Signal generator cable loss</b>									<b>Signal generator cable loss</b>									
Signal generator attenuator loss									Signal generator attenuator loss									
Monopole cable loss									Monopole cable loss									
Monopole attenuator loss									Monopole attenuator loss									
Transform factor of Stripline									Transform factor of Stripline									
Correction factor for size of the EUT									Correction factor for size of the EUT									
Overall measurement correction									Overall measurement correction									



RECEIVER SENSITIVITY (messages)									Date:	PAGE 2 of 2								
Vertical polarization									Horizontal polarization									
Signal generator level (dBm) against angle									Signal generator level (dBm) against angle									
level	0°	45°	90°	135°	180°	225°	270°	325°	level	0°	45°	90°	135°	180°	225°	270°	325°	
1									1									
2									2									
3									3									
4									4									
5									5									
6									6									
7									7									
8									8									
9									9									
10									10									
Ave. $\mu V$									Ave. $\mu V$									
Ave. dBm									Ave. dBm									
LOWEST of the 8 values of dBm above									LOWEST of the 8 values of dBm above									
AVERAGE of the 8 values of dBm above									AVERAGE of the 8 values of dBm above									
<b>For monopole:</b> Received sig. level on receiving device:.....dB $\mu V$									<b>For monopole:</b> Received sig. level on receiving device:.....dB $\mu V$									
<b>For three-axis probe:</b> Field strength in vertical plane:.....dB $\mu V/m$									<b>For three-axis probe:</b> Field strength in vertical plane:.....dB $\mu V/m$									
Calculated field strength:.....dB $\mu V/m$									Calculated field strength:.....dB $\mu V/m$									
Correction factors																		
Signal generator cable loss									Signal generator cable loss									
Signal generator attenuator loss									Signal generator attenuator loss									
Monopole cable loss									Monopole cable loss									
Monopole attenuator loss									Monopole attenuator loss									
Transform factor of Stripline									Transform factor of Stripline									
Correction factor for size of the EUT									Correction factor for size of the EUT									
Overall measurement correction									Overall measurement correction									

### 7.3.1.5 Statement of results

The results should be presented in tabular form as shown in table 9.

**Table 9: Overall results sheet**

RECEIVER SENSITIVITY				Date:	PAGE 1 of 1			
Vertical polarization				Horizontal polarization				
MAXIMUM Usable Sensitivity		$\mu V/m$		MAXIMUM Usable Sensitivity		$\mu V/m$		
AVERAGE Usable Sensitivity		$\mu V/m$		AVERAGE Usable Sensitivity		$\mu V/m$		
Expanded uncertainty (95 %)		dB		Expanded uncertainty (95 %)		dB		

### 7.3.2 Measurement uncertainty for Receiver sensitivity

For tests in which the results of the verification procedure have been used, the test will have comprised only a single measurement stage. Otherwise, two measurement stages of the test would have been involved.

A fully worked example calculation can be found in clause 5 of TR 102 273-1-2 [6].

### 7.3.2.1 Uncertainty contributions: Stage 1: EUT measurement

The first stage involves the measurement set-up as shown in figure 17.

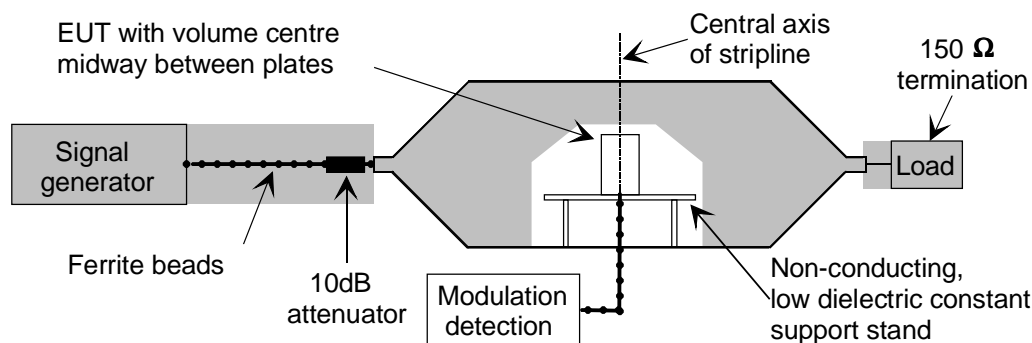

**Figure 17: Stage 1: EUT Measurement**

Table 10 lists the uncertainty contributions involved in this stage of the test. Annex A should be consulted for the sources and/or magnitudes of the uncertainty contributions.

**Table 10: Uncertainty contributions from the EUT measurement**

$u_{j \text{ or } i}$	Description of uncertainty contributions	dB
$u_{j36}$	mismatch: transmitting part	
$u_{j37}$	mismatch: receiving part	
$u_{j38}$	signal generator: absolute output level	
$u_{j39}$	signal generator: output level stability	
$u_{j19}$	cable factor: signal generator	0,00
$u_{j41}$	insertion loss: signal generator cable	0,00
$u_{j40}$	insertion loss: signal generator attenuator	0,00
$u_{j47}$	receiving device: absolute level	0,00
$u_{j48}$	receiving device: linearity	0,00
$u_{j32}$	Stripline: correction factor for the size of the EUT	
$u_{j24}$	Stripline: mutual coupling of the EUT to its images in the plates	
$u_{j55}$	EUT: mutual coupling to the power leads	
$u_{j26}$	Stripline: characteristic impedance	
$u_{j27}$	Stripline: non-planar nature of the field distribution	
$u_{j33}$	Stripline: influence of site effects	
$u_{j34}$	ambient effect	
$u_{j52}$	EUT: modulation detection	
$u_{j01}$	random uncertainty (see note in clause A.18 of TR 102 273-1-2 and note in clause 6.4.7 of TR 102 273-1-1)	

The standard uncertainties from table 10 should be combined by RSS in accordance with clause 5 of TR 102 273-1-1 [5]. This gives the combined standard uncertainty,  $u_c \text{ EUT measurement}$ , for the EUT measurement in dB.

### 7.3.2.2 Uncertainty contributions: Stage 2: Field measurement

For tests using the results of the verification procedure

As stated above, for tests in which the results of the verification procedure are used, this second stage does not really exist. In terms of its contribution to the overall uncertainty of this test, the verification procedure contributes the full value of its overall uncertainty. So, in this case, the standard deviation of the verification procedure is taken as the contribution  $u_c \text{ field measurement}$

For the monopole

Figure 18 shows schematically the equipment set-up for this stage of the test. The uncertainty contributions resulting are given in table 11. Annex A should be consulted for the sources and/or magnitudes of the uncertainty contributions.

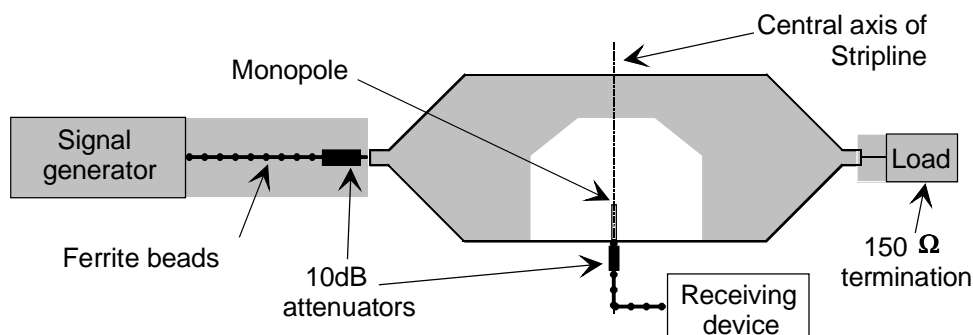

Figure 18: Stage 2 schematic: Monopole field measurement

Table 11: Uncertainty contributions from the monopole field measurement

$u_{j \text{ or } i}$	Description of uncertainty contributions	dB
$u_{j36}$	mismatch: transmitting part	
$u_{j37}$	mismatch: receiving part	
$u_{j47}$	signal generator: absolute output level	
$u_{j48}$	signal generator: output level stability	
$u_{j19}$	cable factor: signal generator	0,00
$u_{j19}$	cable factor: monopole cable	0,00
$u_{j41}$	insertion loss: signal generator cable	0,00
$u_{j41}$	insertion loss: monopole cable	0,00
$u_{j40}$	insertion loss: signal generator attenuator	0,00
$u_{j40}$	insertion loss: monopole attenuator	0,00
$u_{j47}$	receiving device: absolute level	0,00
$u_{j48}$	receiving device: linearity	0,00
$u_{j31}$	Stripline: antenna factor of the monopole	
$u_{j32}$	Stripline: correction factor for the size of the EUT	
$u_{j24}$	Stripline: mutual coupling of the EUT to its images in the plates	
$u_{j26}$	Stripline: characteristic impedance	
$u_{j27}$	Stripline: non-planar nature of the field distribution	
$u_{j33}$	Stripline: influence of site effects	
$u_{j34}$	ambient effect	
$u_{j01}$	random uncertainty (see note in clause A.18 of TR 102 273-1-2 and note in clause 6.4.7 of TR 102 273-1-1)	

The standard uncertainties from table 11 should be combined by RSS in accordance with clause 5 of TR 102 273-1-1 [5]. This gives the combined standard uncertainty,  $u_{c \text{ field measurement}}$ , for the monopole field measurement in dB.

For the three-axis probe

The uncertainty contributions for this configuration during the test are as given in table 12. Annex A should be consulted for the sources and/or magnitudes of the uncertainty contributions.

**Table 12: Uncertainty contributions from the field measurement**

$u_{j \text{ or } i}$	Description of uncertainty contributions	dB
$u_{j36}$	mismatch: transmitting part	
$u_{j38}$	signal generator: absolute output level	
$u_{j39}$	signal generator: output level stability	
$u_{j19}$	cable factor: signal generator	0,00
$u_{j41}$	insertion loss: signal generator cable	0,00
$u_{j40}$	insertion loss: signal generator attenuator	0,00
$u_{j28}$	Stripline: field strength measurement as determined by the three-axis probe	
$u_{j32}$	Stripline: correction factor for the size of the EUT	
$u_{j24}$	Stripline: mutual coupling of the EUT to its images in the plates	
$u_{j26}$	Stripline: characteristic impedance	
$u_{j27}$	Stripline: non-planar nature of the field distribution	
$u_{j33}$	Stripline: influence of site effects	
$u_{j34}$	ambient effect	
$u_{j25}$	Stripline: mutual coupling of the three-axis probe to its image in the plates	
$u_{j01}$	random uncertainty (see note in clause A.18 of TR 102 273-1-2 and note in clause 6.4.7 of TR 102 273-1-1)	

The standard uncertainties from table 12 should be combined by RSS in accordance with clause 5 of TR 102 273-1-1 [5]. This gives the combined standard uncertainty,  $u_{c \text{ field measurement}}$ , for the three-axis probe field measurement in dB.

### 7.3.2.3 Expanded uncertainty for the Receiver sensitivity measurement

The combined standard uncertainty of the results of the receiver sensitivity measurement is the RSS combination of the components outlined in clauses 7.3.2.1 and 7.3.2.2 above. The components to be combined are  $u_{c \text{ EUT measurement}}$  and  $u_{c \text{ field measurement}}$

$$u_c = \sqrt{u_{c \text{ EUT measurement}}^2 + u_{c \text{ field measurement}}^2} = \text{__} \text{ dB} \quad (7.3)$$

The expanded uncertainty is  $\pm 1,96 \times u_c = \pm \text{__} \text{ dB}$  at 95 % confidence level.

### 7.3.3 Co-channel rejection

This test is not usually performed in a Stripline and is therefore not considered here.

### 7.3.4 Adjacent channel selectivity

This test is not usually performed in a Stripline and is therefore not considered here.

### 7.3.5 Intermodulation immunity

This test is not usually performed in a Stripline and is therefore not considered here.

### 7.3.6 Blocking immunity or desensitization

This test is not usually performed in a Stripline and is therefore not considered here.

### 7.3.7 Spurious response rejection

The analysis of this test has not been included in the present document, for this facility.

## Annex A: Bibliography

- "A designers guide to shielding", Hewlett Packard: RF and microwave measurement symposium and exhibition.
- "Analysis of trials on Artificial Human Body", I. L. Gallan and P. R. Brown Interference technology international consultants ltd. Contract ref MC/078.
- "Calculation of site attenuation from antenna factors" A. A. Smith Jr, RF German and J B Pate. IEEE transactions EMC. Vol. EMC 24 pp 301-316 Aug 1982.
- "Computer simulation and measurements of electromagnetic fields close to phantom Humans", Electricity and magnetism in biology and medicine by Martin Blank, Ed 1993 San Francisco Press.
- "Control of errors on Open Area Test Sites", A. A. Smith Jnr. EMC technology October 1982 pages 50-58.
- "Fundamentals of RF and Microwave Power Measurements", Hewlett Packard: Application note 64-1 August 1977.
- "Getting better results from an Open Area Test Site", Joseph DeMarinus.
- "Guide to the evaluation and expression of the uncertainties associated with the results of electrical measurements", Ministry of Defence: 00-26/Issue 2: September 1988.
- "Measurement uncertainty generally", Statens Tekniske Provenaevn, The Danish Accreditation Committee (STP). June 1988 (Danish).
- "Specifications for equipment's for use in the Land Mobile Service" CEPT Recommendation T/R 24-01.
- "Techniques for measuring narrowband and broadband EMI signals using spectrum analysers", Hewlett Packard RF and microwave measurement symposium and exhibition.
- "The expression of uncertainty in electrical measurement", B3003, November 1987 National Measurement Accreditation Service (NAMAS).
- "The gain resistance product of the half-wave dipole", W. Scott Bennet Proceedings of IEEE vol. 72 No. 2 Dec 1984 pp 1824-1826.
- "Uncertainties of Measurement for NATLAS electrical testing laboratories. NAMAS policy and general notes", National Testing Laboratory Accreditation Scheme (NATLAS), NIS20 July 1986 (English)
- "Use of Simulated Human Bodies in pager receiver sensitivity measurements", K.Siwiak and W.Elliott III. Southcom /92 conference, Orlando 1992. pp 189/92.
- "Usikkerhed pa maleresultater" (Per Bennich, Institute for Product Development: "Uncertainty of measured results"). October 1988. (Danish).
- "Calculation of site attenuation from antenna factors" A. A. Smith Jr, RF German and J B Pate. IEEE transactions EMC. Vol. EMC 24 pp 301-316 Aug 1982.
- "Standard site method for determining antenna factors", A. A. Smith Jr. IEEE transactions EMC. Vol EMC 24 pp 316-322 Aug 1982.
- 50(161) IEC 1990.
- "Advanced National certificate mathematics", PEDOE, Hodder and Stoughton Volumes I and II.
- "Antenna engineering handbook", R. C. Johnson, H. Jasik.
- "Antenna Theory: Analysis and Design", 2nd Edition, Constantine A. Balanis (1996).
- "Antennas and radio wave propagation", R. E. Collin, McGraw Hill.
- "Antennas", John D. Kraus, Second edition, McGraw Hill.

- "Chambers Science and Technology dictionary", 1988. Published by Chambers Cambridge.
- "Digital Communications", John G. Proakis, McGraw-Hill International Editions, second edition.
- "Guide to the Expression of Uncertainty in Measurement", (International Organization for Standardization, Geneva, Switzerland, 1995).
- "Radiowave propagation and antennas for personal communications", K. Siwiak, Artech House Publications.
- "The new IEEE standard dictionary of electrical and electronic terms". Fifth edition, IEEE Piscataway, NJ USA 1993.
- "The telecommunications factbook and illustrated dictionary", Kahn, Delmar publications Inc. New York 1992.
- "Vocabulary of metrology", British Standard Institution (BSI): PD 6461: Part 2: September 1980.
- "Wave transmission", F. R. Conner, Arnold 1978.

---

## History

<b>Document history</b>		
Edition 1	February 1998	Publication as ETR 273-5
V1.2.1	December 2001	Publication