

**Electromagnetic compatibility
and Radio spectrum Matters (ERM);
Improvement on Radiated Methods
of Measurement (using test site) and evaluation
of the corresponding measurement uncertainties
Part 6: Test fixtures**



Reference

RTR/ERM-RP02-057-6

Keywordsanalogue, data, measurement uncertainty,
mobile, radio, testing**ETSI**

650 Route des Lucioles
F-06921 Sophia Antipolis Cedex - FRANCE

Tel.: +33 4 92 94 42 00 Fax: +33 4 93 65 47 16

Siret N° 348 623 562 00017 - NAF 742 C
Association à but non lucratif enregistrée à la
Sous-Préfecture de Grasse (06) N° 7803/88

Important notice

Individual copies of the present document can be downloaded from:

<http://www.etsi.org>

The present document may be made available in more than one electronic version or in print. In any case of existing or perceived difference in contents between such versions, the reference version is the Portable Document Format (PDF). In case of dispute, the reference shall be the printing on ETSI printers of the PDF version kept on a specific network drive within ETSI Secretariat.

Users of the present document should be aware that the document may be subject to revision or change of status. Information on the current status of this and other ETSI documents is available at

<http://portal.etsi.org/tb/status/status.asp>

If you find errors in the present document, send your comment to:

editor@etsi.fr

Copyright Notification

No part may be reproduced except as authorized by written permission.
The copyright and the foregoing restriction extend to reproduction in all media.

© European Telecommunications Standards Institute 2001.
All rights reserved.

Contents

Intellectual Property Rights	5
Foreword.....	5
1 Scope	6
2 References	6
3 Definitions, symbols and abbreviations	7
3.1 Definitions	7
3.2 Symbols.....	11
3.3 Abbreviations	13
4 Introduction	13
4.1 Performance limitations	14
4.2 Summary	15
5 Uncertainty contributions specific to test fixtures.....	15
5.1 Test Fixture effect	16
5.2 Climatic facility effect.....	16
5.2.1 Resonances within a climatic facility.....	16
5.2.2 Internal reflections using a climatic facility.....	17
5.2.3 Mutual coupling effects using a climatic facility.....	17
5.2.4 Waveguide-type modes within a climatic facility.....	17
5.2.5 Summary.....	18
6 Verification procedure for a test fixture	18
6.1 Definition	18
6.2 Overview of the verification procedure.....	18
6.2.1 Apparatus required.....	19
6.2.2 Site preparation.....	19
6.2.3 Measurement configuration	19
6.2.4 What to record	19
6.3 Verification procedure.....	19
6.4 Processing the results of the verification procedure	23
6.5 Calculation of measurement uncertainty	24
7 Test methods	24
7.1 Introduction	24
7.1.1 Site preparation	24
7.1.2 Preparation of the EUT	25
7.1.3 Power supplies to the EUT	25
7.2 Transmitter tests	25
7.2.1 Frequency error (30 MHz to 1 000 MHz).....	25
7.2.1.1 Apparatus required.....	25
7.2.1.2 Method of measurement.....	26
7.2.1.3 Procedure for completion of the results sheets.....	27
7.2.1.4 Log book entries.....	28
7.2.1.5 Statement of results	28
7.2.2 Expanded uncertainty for frequency error test.....	28
7.2.3 Effective radiated power (30 MHz to 1 000 MHz)	29
7.2.3.1 Apparatus required.....	29
7.2.3.2 Method of measurement.....	29
7.2.3.3 Procedure for the completion of the results sheets	31
7.2.3.4 Log book entries.....	32
7.2.3.5 Statement of results	32
7.2.4 Uncertainty for effective radiated power measurement	33
7.2.4.1 Expanded uncertainty for Effective radiated power measurement.....	33
7.2.5 Spurious emissions (30 MHz to 4 GHz or 12,75 GHz)	33
7.2.6 Adjacent channel power (30 MHz to 1 000 MHz).....	33

7.2.6.1	Apparatus required	33
7.2.6.2	Method of measurement	34
7.2.6.3	Procedure for completion of the results sheets	36
7.2.6.4	Log book entries	37
7.2.6.5	Statement of results	38
7.2.7	Measurement uncertainty for Adjacent channel power	38
7.2.7.1	Expanded uncertainty of the Adjacent channel power measurement	39
7.3	Receiver tests	39
7.3.1	Maximum usable sensitivity (30 MHz to 1 000 MHz)	39
7.3.1.1	Apparatus required	40
7.3.1.2	Method of measurement	40
7.3.1.3	Procedure for the completion of the results sheets	43
7.3.1.4	Log book entries	44
7.3.1.5	Statement of results	46
7.3.2	Measurement uncertainty for Maximum usable sensitivity	46
7.3.2.1	Expanded uncertainty of the maximum usable sensitivity measurement	46
7.3.3	Average usable sensitivity	46
7.3.4	Co-channel rejection	46
7.3.4.1	Apparatus required	47
7.3.4.2	Method of measurement	48
7.3.4.3	Procedure for completion of the results sheets	51
7.3.4.4	Log book entries	53
7.3.4.5	Overall results sheet	56
7.3.5	Measurement uncertainty for Co-channel rejection	57
7.3.5.1	Expanded uncertainty of the co-channel rejection measurement	57
7.3.6	Adjacent channel selectivity	57
7.3.6.1	Apparatus required	58
7.3.6.2	Method of measurement	58
7.3.6.3	Procedure for completion of the results sheets	62
7.3.6.4	Log book entries	63
7.3.6.5	Overall results sheet	65
7.3.7	Measurement uncertainty for adjacent channel selectivity	66
7.3.7.1	Expanded uncertainty of the adjacent channel selectivity measurement	66
7.3.8	Intermodulation immunity	66
7.3.8.1	Apparatus required	67
7.3.8.2	Method of measurement	67
7.3.8.3	Procedure for completion of the results sheets	71
7.3.8.4	Log book entries	73
7.3.8.5	Overall results sheet	75
7.3.9	Measurement uncertainty for Intermodulation immunity	76
7.3.9.1	Expanded uncertainty of the Intermodulation immunity measurement	76
7.3.10	Blocking immunity (or desensitization)	76
7.3.10.1	Apparatus required	77
7.3.10.2	Method of measurement	77
7.3.10.3	Procedure for completion of the results sheets	81
7.3.10.4	Log book entries	82
7.3.10.5	Overall results sheet	86
7.3.11	Measurement uncertainty for blocking immunity (or desensitization)	86
7.3.11.1	Expanded uncertainty of the blocking immunity (or desensitization) measurement	86
7.3.12	Spurious response rejection	86
Annex A:	Bibliography	87
History		89

Intellectual Property Rights

IPRs essential or potentially essential to the present document may have been declared to ETSI. The information pertaining to these essential IPRs, if any, is publicly available for **ETSI members and non-members**, and can be found in ETSI SR 000 314: *"Intellectual Property Rights (IPRs); Essential, or potentially Essential, IPRs notified to ETSI in respect of ETSI standards"*, which is available from the ETSI Secretariat. Latest updates are available on the ETSI Web server (<http://webapp.etsi.org/IPR/home.asp>).

Pursuant to the ETSI IPR Policy, no investigation, including IPR searches, has been carried out by ETSI. No guarantee can be given as to the existence of other IPRs not referenced in ETSI SR 000 314 (or the updates on the ETSI Web server) which are, or may be, or may become, essential to the present document.

Foreword

This Technical Report (TR) has been produced by ETSI Technical Committee Electromagnetic compatibility and Radio spectrum Matters (ERM).

The present document is part 6 of a multi-part deliverable covering Improvement on radiated methods of measurement (using test site) and evaluation of the corresponding measurement uncertainties, as identified below:

Part 1: "Uncertainties in the measurement of mobile radio equipment characteristics";

Sub-part 1: "Introduction";

Sub-part 2: "Examples and annexes";

Part 2: "Anechoic chamber";

Part 3: "Anechoic chamber with a ground plane";

Part 4: "Open area test site";

Part 5: "Striplines";

Part 6: "Test fixtures";

Part 7: "Artificial human beings".

1 Scope

The present document provides background to the subject of measurement uncertainty and proposes extensions and improvements relevant to radiated measurements. It also details the methods of radiated measurements (test methods for mobile radio equipment parameters and verification procedures for test sites) and additionally provides the methods for evaluating the associated measurement uncertainties.

The present document provides a method to be used together with all the applicable standards and (E)TRs, supports TR 100 027 [3] and can be used with TR 100 028 [8].

The present document covers the test methods for performing radiated measurements on mobile radio equipment using a Test Fixture and also provides the methods for evaluation and calculation of the measurement uncertainties for each of the measured parameters.

2 References

For the purposes of this Technical Report (TR), the following references apply:

- [1] ITU-T Recommendation O.41: "Psophometer for use on telephone-type circuits".
- [2] ITU-T Recommendation O.153: "Basic parameters for the measurement of error performance at bit rates below the primary rate".
- [3] ETSI TR 100 027: "Electromagnetic compatibility and Radio spectrum Matters (ERM); Methods of measurement for private mobile radio equipment".
- [4] ETSI TR 102 273-1-1: "ElectroMagnetic Compatibility and Radio Spectrum Matters (ERM); Improvement on Radiated Methods of Measurement (using test site) and evaluation of the corresponding measurement uncertainties Part 1: Uncertainties in the measurement of mobile radio equipment characteristics; Sub-part 1: Introduction".
- [5] ETSI TR 102 273-2: "ElectroMagnetic Compatibility and Radio Spectrum Matters (ERM); Improvement on Radiated Methods of Measurement (using test site) and evaluation of the corresponding measurement uncertainties; Part 2: Anechoic chamber".
- [6] ETSI TR 102 273-3: "ElectroMagnetic Compatibility and Radio Spectrum Matters (ERM); Improvement on Radiated Methods of Measurement (using test site) and evaluation of the corresponding measurement uncertainties; Part 3: Anechoic chamber with a ground plane".
- [7] ETSI TR 102 273-4: "ElectroMagnetic Compatibility and Radio Spectrum Matters (ERM); Improvement on Radiated Methods of Measurement (using test site) and evaluation of the corresponding measurement uncertainties; Part 4: Open area test site".
- [8] ETSI TR 100 028 (V1.4.1) (parts 1 and 2): "Electromagnetic compatibility and Radio spectrum Matters (ERM); Uncertainties in the measurement of mobile radio equipment characteristics".

3 Definitions, symbols and abbreviations

3.1 Definitions

For the purposes of the present document, the following terms and definitions apply:

accuracy: this term is defined, in relation to the measured value, in clause 4.1.1; it has also been used in the remainder of the document in relation to instruments

Audio Frequency (AF) load: normally a resistor of sufficient power rating to accept the maximum audio output power from the EUT. The value of the resistor is normally that stated by the manufacturer and is normally the impedance of the audio transducer at 1 000 Hz

NOTE: In some cases it may be necessary to place an isolating transformer between the output terminals of the receiver under test and the load.

AF termination: any connection other than the audio frequency load which may be required for the purpose of testing the receiver (i.e. in a case where it is required that the bit stream be measured, the connection may be made, via a suitable interface, to the discriminator of the receiver under test)

NOTE: The termination device is normally agreed between the manufacturer and the testing authority and details included in the test report. If special equipment is required then it is normally provided by the manufacturer.

A-M1: test modulation consisting of a 1 000 Hz tone at a level which produces a deviation of 12 % of the channel separation

A-M2: test modulation consisting of a 1 250 Hz tone at a level which produces a deviation of 12 % of the channel separation

A-M3: test modulation consisting of a 400 Hz tone at a level which produces a deviation of 12 % of the channel separation. This signal is used as an unwanted signal for analogue and digital measurements

antenna: that part of a transmitting or receiving system that is designed to radiate or to receive electromagnetic waves

antenna factor: quantity relating the strength of the field in which the antenna is immersed to the output voltage across the load connected to the antenna. When properly applied to the meter reading of the measuring instrument, yields the electric field strength in V/m or the magnetic field strength in A/m

antenna gain: the ratio of the maximum radiation intensity from an (assumed lossless) antenna to the radiation intensity that would be obtained if the same power were radiated isotropically by a similarly lossless antenna

bit error ratio: the ratio of the number of bits in error to the total number of bits

combining network: network allowing the addition of two or more test signals produced by different sources (e.g. for connection to a receiver input)

NOTE: Sources of test signals are normally connected in such a way that the impedance presented to the receiver is 50 Ω . Combining networks are designed so that effects of any intermodulation products and noise produced in the signal generators are negligible.

correction factor: the numerical factor by which the uncorrected result of a measurement is multiplied to compensate for an assumed systematic error.

confidence level: the probability of the accumulated error of a measurement being within the stated range of uncertainty of measurement

directivity: the ratio of the maximum radiation intensity in a given direction from the antenna to the radiation intensity averaged over all directions (i.e. directivity = antenna gain + losses)

DM-0: test modulation consisting of a signal representing an infinite series of "0" bits

DM-1: test modulation consisting of a signal representing an infinite series of "1" bits

DM-2: test modulation consisting of a signal representing a pseudorandom bit sequence of at least 511 bits in accordance with ITU-T Recommendation O.153

D-M3: test signal agreed between the testing authority and the manufacturer in the cases where it is not possible to measure a bit stream or if selective messages are used and are generated or decoded within an equipment

NOTE: The agreed test signal may be formatted and may contain error detection and correction. Details of the test signal are to be supplied in the test report.

duplex filter: device fitted internally or externally to a transmitter/receiver combination to allow simultaneous transmission and reception with a single antenna connection

error of measurement (absolute): the result of a measurement minus the true value of the measurand

error (relative): the ratio of an error to the true value

estimated standard deviation: from a sample of n results of a measurement the estimated standard deviation is given by the formula:

$$\sigma = \sqrt{\frac{\sum_{i=1}^n (x_i - \bar{x})^2}{n-1}}$$

x_i being the i^{th} result of measurement ($i = 1, 2, 3, \dots, n$) and \bar{x} the arithmetic mean of the n results considered.

A practical form of this formula is:

$$\sigma = \sqrt{\frac{Y - \frac{X^2}{n}}{n-1}}$$

where X is the sum of the measured values and Y is the sum of the squares of the measured values.

The term **standard deviation** has also been used in the present document to characterize a particular probability density. Under such conditions, the term **standard deviation** may relate to situations where there is only one result for a measurement.

expansion factor: multiplicative factor used to change the confidence level associated with a particular value of a measurement uncertainty.

The mathematical definition of the expansion factor can be found in clause D.5.6.2.2 of TR 100 028-2 [8].

extreme test conditions: conditions defined in terms of temperature and supply voltage. Tests are normally made with the extremes of temperature and voltage applied simultaneously. The upper and lower temperature limits are specified in the relevant testing standard. The test report states the actual temperatures measured

error (of a measuring instrument): the indication of a measuring instrument minus the (conventional) true value

free field: field (wave or potential) which has a constant ratio between the electric and magnetic field intensities

free space: region free of obstructions and characterized by the constitutive parameters of a vacuum

impedance: measure of the complex resistive and reactive attributes of a component in an alternating current circuit

impedance (wave): the complex factor relating the transverse component of the electric field to the transverse component of the magnetic field at every point in any specified plane, for a given mode

influence quantity: quantity which is not the subject of the measurement but which influences the value of the quantity to be measured or the indications of the measuring instrument

intermittent operation: operation where the manufacturer states the maximum time that the equipment is intended to transmit and the necessary standby period before repeating a transmit period

isotropic radiator: hypothetical, lossless antenna having equal radiation intensity in all directions

limited frequency range: the limited frequency range is a specified smaller frequency range within the full frequency range over which the measurement is made

NOTE: The details of the calculation of the limited frequency range are normally given in the relevant testing standard.

maximum permissible frequency deviation: the maximum value of frequency deviation stated for the relevant channel separation in the relevant testing standard

measuring system: complete set of measuring instruments and other equipment assembled to carry out a specified measurement task

measurement repeatability: the closeness of the agreement between the results of successive measurements of the same measurand carried out subject to all the following conditions:

- the same method of measurement;
- the same observer;
- the same measuring instrument;
- the same location;
- the same conditions of use;
- repetition over a short period of time.

measurement reproducibility: the closeness of agreement between the results of measurements of the same measurand, where the individual measurements are carried out changing conditions such as:

- method of measurement;
- observer;
- measuring instrument;
- location;
- conditions of use;
- time.

measurand: quantity subjected to measurement

noise gradient of EUT: function characterizing the relationship between the RF input signal level and the performance of the EUT, e.g. the SINAD of the AF output signal

nominal frequency: one of the channel frequencies on which the equipment is designed to operate

nominal mains voltage: the declared voltage or any of the declared voltages for which the equipment was designed

normal test conditions: the conditions defined in terms of temperature, humidity and supply voltage stated in the relevant testing standard

normal deviation: the frequency deviation for analogue signals which is equal to 12 % of the channel separation

psophometric weighting network: as described in ITU-T Recommendation O.41

polarization: for an electromagnetic wave, the figure traced as a function of time by the extremity of the electric vector at a fixed point in space

quantity (measurable): an attribute of a phenomenon or a body which may be distinguished qualitatively and determined quantitatively

rated audio output power: the maximum audio output power under normal test conditions, and at standard test modulations, as declared by the manufacturer

rated radio frequency output power: the maximum carrier power under normal test conditions, as declared by the manufacturer

shielded enclosure: structure that protects its interior from the effects of an exterior electric or magnetic field, or conversely, protects the surrounding environment from the effect of an interior electric or magnetic field

SINAD sensitivity: the minimum standard modulated carrier-signal input required to produce a specified SINAD ratio at the receiver output

stochastic (random) variable: variable whose value is not exactly known, but is characterized by a distribution or probability function, or a mean value and a standard deviation (e.g. a measurand and the related measurement uncertainty)

test load: the test load is a 50 Ω substantially non-reactive, non-radiating power attenuator which is capable of safely dissipating the power from the transmitter

test modulation: the test modulating signal is a baseband signal which modulates a carrier and is dependent upon the type of EUT and also the measurement to be performed

trigger device: circuit or mechanism to trigger the oscilloscope timebase at the required instant. It may control the transmit function or inversely receive an appropriate command from the transmitter

uncertainty (random): component of the uncertainty of measurement which, in the course of a number of measurements of the same measurand, varies in an unpredictable way (to be considered as a component for the calculation of the combined uncertainty when the effects it corresponds to have not been taken into consideration otherwise)

uncertainty (systematic): component of the uncertainty of measurement which, in the course of a number of measurements of the same measurand remains constant or varies in a predictable way

uncertainty (limits of uncertainty of a measuring instrument): the extreme values of uncertainty permitted by specifications, regulations etc. for a given measuring instrument

NOTE: This term is also known as "tolerance".

uncertainty (standard): an expression characterizing, for each individual uncertainty component, the uncertainty for that component

It is the standard deviation of the corresponding distribution.

uncertainty (combined standard): the combined standard uncertainty is calculated by combining appropriately the standard uncertainties for each of the individual contributions identified in the measurement considered or in the part of it, which has been considered

NOTE: In the case of additive components (linearly combined components where all the corresponding coefficients **are equal to one**) and when all these contributions are independent of each other (stochastic), this combination is calculated by using the Root of the Sum of the Squares (the RSS method). A more complete methodology for the calculation of the combined standard uncertainty is given in annex D, see in particular clause D.3.12, TR 100 028-2 [8].

uncertainty (expanded): the expanded uncertainty is the uncertainty value corresponding to a specific confidence level different from that inherent to the calculations made in order to find the combined standard uncertainty

The combined standard uncertainty is multiplied by a constant to obtain the expanded uncertainty limits (see clause 5.3 of TR 100 028-1 [8], and also clause D.5 (and more specifically clause D.5.6.2) of TR 100 028-2 [8]).

upper specified AF limit: the maximum audio frequency of the audio pass-band. It is dependent on the channel separation

wanted signal level: for conducted measurements a level of +6 dB μ V emf referred to the receiver input under normal test conditions. Under *extreme test conditions* the value is +12 dB μ V emf

NOTE: For analogue measurements the wanted signal level has been chosen to be equal to the limit value of the measured usable sensitivity. For bit stream and message measurements the wanted signal has been chosen to be +3 dB above the limit value of measured usable sensitivity.

3.2 Symbols

For the purposes of the present document, the following symbols apply:

β	$2\pi/\lambda$ (radians/m);
γ	incidence angle with ground plane ($^{\circ}$)
λ	wavelength (m)
ϕ_H	phase angle of reflection coefficient ($^{\circ}$)
η	120π Ohms - the intrinsic impedance of free space (Ω)
μ	permeability (H/m)
AF_R	Antenna Factor of the receive antenna (dB/m)
AF_T	Antenna Factor of the transmit antenna (dB/m)
AF_{TOT}	mutual coupling correction Antenna Factor (dB)
C_{cross}	cross correlation Coefficient
$D(\theta, \phi)$	Directivity of the source
d	distance between dipoles (m)
δ	skin depth (m)
d_1	an antenna or EUT aperture size (m)
d_2	an antenna or EUT aperture size (m)
d_{dir}	path length of the direct signal (m)
d_{refl}	path length of the reflected signal (m)
E	electric field intensity (V/m)
E_{DH}^{max}	calculated maximum Electric field strength in the receiving antenna height scan from a half wavelength dipole with 1 pW of radiated power (for horizontal polarization) (μ V/m)
E_{DV}^{max}	calculated maximum Electric field strength in the receiving antenna height scan from a half wavelength dipole with 1 pW of radiated power (for vertical polarization) (μ V/m)
e_{ff}	antenna efficiency factor
ϕ	angle ($^{\circ}$)
Δf	bandwidth (Hz)
f	frequency (Hz)
$G(\theta, \phi)$	Gain of the source (which is the source directivity multiplied by the antenna efficiency factor)
H	magnetic field intensity (A/m)
I_0	the (assumed constant) current (A)
I_m	the maximum current amplitude
k	$2\pi/\lambda$
k	a factor from Student's t distribution
k	Boltzmann's constant ($1,38 \times 10^{-23}$ Joules/ $^{\circ}$ Kelvin)
K	relative dielectric constant
l	the length of the infinitesimal dipole (m)
L	the overall length of the dipole (m)
l	the point on the dipole being considered (m)
$Pe_{(n)}$	Probability of error n
$Pp_{(n)}$	Probability of position n
P_r	antenna noise Power (W)
P_{rec}	Power received (W)
P_t	Power transmitted (W)
θ	angle ($^{\circ}$)
ρ	reflection coefficient
r	the distance to the field point (m)
ρ_g	reflection coefficient of the generator part of a connection
ρ_l	reflection coefficient of the load part of the connection
R_s	equivalent surface Resistance (Ω)
σ	conductivity (S/m)
σ	standard deviation
SNR_{b^*}	Signal to Noise Ratio at a specific BER

SNR_b	Signal to Noise Ratio per bit
T_A	antenna Temperature ($^{\circ}$ Kelvin)
U	the expanded Uncertainty corresponding to a confidence level of $x\%$: $U = k \times u_c$
u_c	the combined standard uncertainty
u_i	general type A standard uncertainty
u_{i01}	random uncertainty
u_j	general type B uncertainty
u_{j01}	reflectivity of absorbing material: EUT to the test antenna
u_{j02}	reflectivity of absorbing material: substitution or measuring antenna to the test antenna
u_{j03}	reflectivity of absorbing material: transmitting antenna to the receiving antenna
u_{j04}	mutual coupling: EUT to its images in the absorbing material
u_{j05}	mutual coupling: de-tuning effect of the absorbing material on the EUT
u_{j06}	mutual coupling: substitution, measuring or test antenna to its image in the absorbing material
u_{j07}	mutual coupling: transmitting or receiving antenna to its image in the absorbing material
u_{j08}	mutual coupling: amplitude effect of the test antenna on the EUT
u_{j09}	mutual coupling: de-tuning effect of the test antenna on the EUT
u_{j10}	mutual coupling: transmitting antenna to the receiving antenna
u_{j11}	mutual coupling: substitution or measuring antenna to the test antenna
u_{j12}	mutual coupling: interpolation of mutual coupling and mismatch loss correction factors
u_{j13}	mutual coupling: EUT to its image in the ground plane
u_{j14}	mutual coupling: substitution, measuring or test antenna to its image in the ground plane
u_{j15}	mutual coupling: transmitting or receiving antenna to its image in the ground plane
u_{j16}	range length
u_{j17}	correction: off boresight angle in the elevation plane
u_{j18}	correction: measurement distance
u_{j19}	cable factor
u_{j20}	position of the phase centre: within the EUT volume
u_{j21}	positioning of the phase centre: within the EUT over the axis of rotation of the turntable
u_{j22}	position of the phase centre: measuring, substitution, receiving, transmitting or test antenna
u_{j23}	position of the phase centre: LPDA
u_{j24}	stripline: mutual coupling of the EUT to its images in the plates
u_{j25}	stripline: mutual coupling of the 3-axis probe to its image in the plates
u_{j26}	stripline: characteristic impedance
u_{j27}	stripline: non-planar nature of the field distribution
u_{j28}	stripline: field strength measurement as determined by the 3-axis probe
u_{j29}	stripline: Transform Factor
u_{j30}	stripline: interpolation of values for the Transform Factor
u_{j31}	stripline: antenna factor of the monopole
u_{j32}	stripline: correction factor for the size of the EUT
u_{j33}	stripline: influence of site effects
u_{j34}	ambient effect
u_{j35}	mismatch: direct attenuation measurement
u_{j36}	mismatch: transmitting part
u_{j37}	mismatch: receiving part
u_{j38}	signal generator: absolute output level
u_{j39}	signal generator: output level stability
u_{j40}	insertion loss: attenuator
u_{j41}	insertion loss: cable
u_{j42}	insertion loss: adapter
u_{j43}	insertion loss: antenna balun

u_{j44}	antenna: antenna factor of the transmitting, receiving or measuring antenna
u_{j45}	antenna: gain of the test or substitution antenna
u_{j46}	antenna: tuning
u_{j47}	receiving device: absolute level
u_{j48}	receiving device: linearity
u_{j49}	receiving device: power measuring receiver
u_{j50}	EUT: influence of the ambient temperature on the ERP of the carrier
u_{j51}	EUT: influence of the ambient temperature on the spurious emission level
u_{j52}	EUT: degradation measurement
u_{j53}	EUT: influence of setting the power supply on the ERP of the carrier
u_{j54}	EUT: influence of setting the power supply on the spurious emission level
u_{j55}	EUT: mutual coupling to the power leads
u_{j56}	frequency counter: absolute reading
u_{j57}	frequency counter: estimating the average reading
u_{j58}	salty man/salty-lite: human simulation
u_{j59}	salty man/salty-lite: field enhancement and de-tuning of the EUT
u_{j60}	test fixture: effect on the EUT
u_{j61}	test fixture: climatic facility effect on the EUT
V_{direct}	received Voltage for cables connected via an adapter (dB μ V/m)
V_{site}	received Voltage for cables connected to the antennas (dB μ V/m)
W_0	radiated power density (W/m ²)

3.3 Abbreviations

For the purposes of the present document, the following abbreviations apply:

AF	Audio Frequency
A-M1	is a test modulation consisting of a 1 000 Hz tone at a level which produces a deviation of 12 % of the channel separation
A-M2	is a test modulation consisting of a 1 250 Hz tone at a level which produces a deviation of 12 % of the channel separation
A-M3	is a test modulation consisting of a 400 Hz tone at a level which produces a deviation of 12 % of the channel separation. This signal is used as an unwanted signal for analogue and digital measurements
BER	Bit Error Ratio
c	calculated on the basis of given and measured data
d	derived from a measuring equipment specification
emf	electromotive force
EUT	Equipment Under Test
m	measured
r	indicates rectangular distribution
RF	Radio Frequency
RSS	Root-Sum-of-the-Squares
VSWR	Voltage Standing Wave Ratio

4 Introduction

A Test Fixture is usually constructed for testing a specific EUT. It consists of a 50 Ω RF connector and a device for electromagnetically coupling to the EUT. It should also incorporate a means for repeatable positioning of the EUT. Figure 1 illustrates a typical Test Fixture.

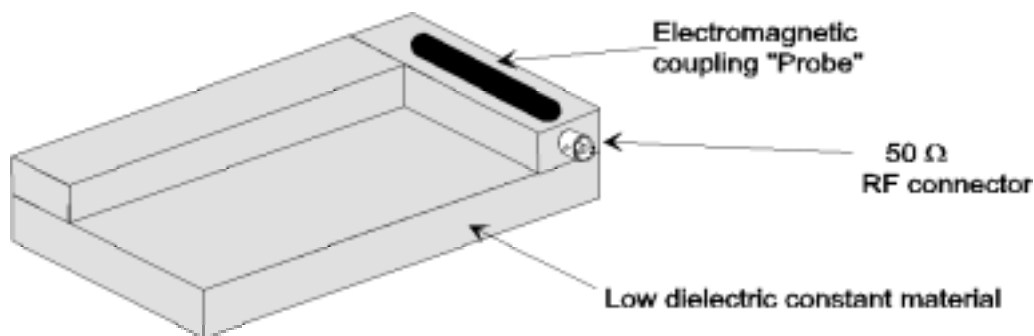

Figure 1: Basic, typical Test Fixture

The coupling device usually comprises a small antenna that is placed, physically and electrically, close to the EUT. This antenna/coupling device is used for sampling or generating the test fields when the EUT is undergoing testing, usually at extreme conditions of temperature and/or voltage.

Test fixtures should be constructed in such a way that measurements are repeatable. This requires some specific mounting arrangements to be incorporated within the test fixture to secure the EUT in a fixed, repeatable position. Such mounting arrangements would additionally help to maintain the relative polarization between the EUT and the coupling device. A typical scheme is shown in figure 2.

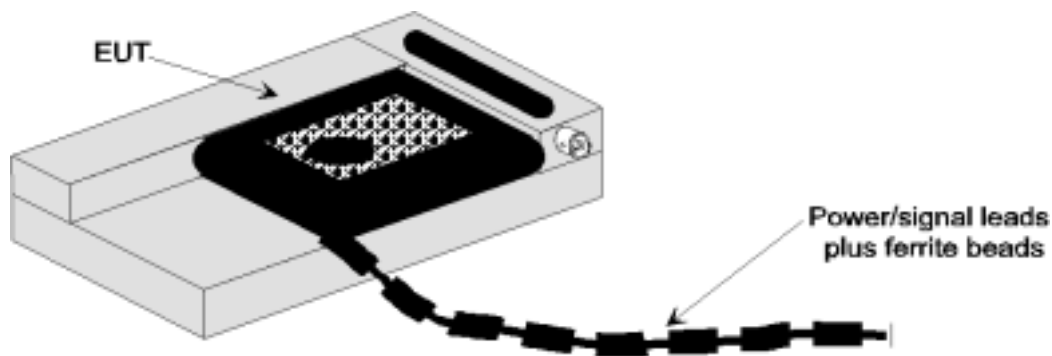

Figure 2: EUT mounted in a typical test fixture

A test fixture should enable adequate access to the EUT for interfacing with the test equipment. In particular, it should provide, where relevant, access to:

- the "press to talk" button for a transmitter;
- the modulator input for a transmitter;
- the audio output for a receiver;
- the power terminals for connection to an external power supply.

The entire assembly of test fixture plus EUT is generally extremely compact and it can be regarded as a miniature test site. Its compactness enables the whole assembly to be accommodated within a test chamber (usually a climatic facility) that completely encloses the extreme condition.

The circuitry associated with the RF coupling device should contain no active or non-linear components and should present a VSWR of better than 1,5:1 to a 50 Ω line.

4.1 Performance limitations

The coupling mechanism between the EUT and the test fixture is extremely complex since the two are placed physically and electrically very close together. This complexity makes any attempt at theoretically modelling a test fixture's performance not only very difficult but also time consuming and costly. In practice, therefore, modelling is seldom attempted. The direct consequence of this is that absolute measurements cannot be made in a test fixture and any measurement results have to be related, in some way, to results taken on a verified free field test site.

The usual way to relate the results is by a process, sometimes referred to as field equalization, in which the relevant parameter (effective radiated power, receiver sensitivity, etc.) is initially measured on a free field test site under normal conditions and then subsequently re-measured using only the test fixture (with the EUT installed) also under normal conditions. The difference (in dB) of the two results (received signal level for an effective radiated power test, output power from a signal generator for a sensitivity test) is termed the coupling factor of the test fixture and provides the link between all the results of EUT tests carried out in the test fixture and its performance on a verified free field test site. As a general rule, the coupling factor should not be greater than 20 dB.

To reiterate, this key limitation for a test fixture can be stated in two ways:

- only relative measurements can be made;
- absolute measurements cannot be made.

A further limitation to the use of a test fixture results from the unknown variation of the coupling factor with frequency. This variation cannot be relied upon to be linear over large bandwidths and this puts a limit on those tests which can be accurately carried out. As a result, emission tests are generally limited to the nominal frequencies (for which the performance of the test fixture has been verified) of low power devices for effective radiated power and frequency error tests. Occasionally, however, adjacent channel power is measured.

Similarly, receiver tests are normally limited to receiver sensitivity although, occasionally, co-channel rejection, adjacent channel selectivity, inter-modulation immunity and blocking are tested.

Ideally, all test fixtures should be verified and where EUT testing will be required over a frequency band, the verification procedure should be extended to include the frequencies at the band edges. In any case, routine verification, perhaps every six months, should be carried out as a means of detecting any deterioration or change in performance.

Local ambient signals can be problematic to measurements carried out in a test fixture, although very little uncertainty is introduced into transmitter tests, since EUT power levels will dominate. However, for receiver tests (i.e. sensitivity and various types of immunity testing) shielding from ambient signals may be required. Adequate shielding can be achieved by either using the test fixture within a metalized test chamber (e.g. climatic facility) or by enclosing it within a shielded room. In either case, one needs to be aware of the possible frequencies of resonance for these structures.

Only integral antenna devices are tested in a test fixture. For devices possessing either permanent or temporary external RF connectors, all testing is carried out using conducted methods.

4.2 Summary

Test Fixtures are tools that allow the measurement of certain radio parameters of an EUT whilst it is subjected to extremes of either voltage or temperature or both. They only allow relative measurements to be carried out since its coupling mechanism to the EUT is extremely complex, making it virtually impossible to calculate an absolute coupling factor.

Only after it has been verified that the test fixture does not affect performance can the EUT be confidently tested under extreme conditions. As a result of verifying the test fixture and equating the performance of the EUT in the test fixture under normal conditions to results taken on a free field test site, the EUT's performance at an extreme condition can be directly related to the free-field measurements.

5 Uncertainty contributions specific to test fixtures

There are essentially two main sources of error that contribute to tests involving a test fixture. Firstly, the effect that the close physical presence of the test fixture has on the EUT and secondly the overall effect produced by the climatic facility. Both these sources are quite complex and are discussed below.

5.1 Test Fixture effect

This effect is a result of the close proximity of the test fixture to the EUT. It is a combination of a detuning effect on the EUT produced by the dielectric constant of the materials from which the test fixture is constructed and various mutual coupling and reflection effects arising from the interaction between the EUT and components within the test fixture e.g. the coupling probe, RF connector, etc. The overall magnitude of this effect is determined during the verification procedure and is used to decide if the test fixture degrades EUT performance unacceptably.

u_{j60} is used for the uncertainty contribution associated with the test fixture effect on the EUT as determined during the verification procedure.

5.2 Climatic facility effect

This effect can be broken down into several constituent parts. These parts include resonances due to the dimensions of the climatic facility itself, internal reflections from the metallic walls, mutual coupling effects and the possible propagation of waveguide type modes. All of these effects cause disruption to the field distribution within the facility.

5.2.1 Resonances within a climatic facility

To fully contain and control the extreme conditions in which the EUT is tested, the test fixture is usually placed within a climatic test facility. For those cases in which the sides of the climatic facility are metal, the enclosed chamber will, by acting as a waveguide cavity, exhibit resonances. (Non metallic walls will also produce resonances but the associated Q-factors will be relatively low.) The approximate frequencies of these resonances can be easily calculated provided the climatic facility is of rectangular cross section in all three planes. These frequencies are given in MHz by the following formula:

$$f = 150 \sqrt{\left(\frac{x}{l}\right)^2 + \left(\frac{y}{b}\right)^2 + \left(\frac{z}{h}\right)^2} \text{ MHz} \quad (5.1)$$

where l , b and h are (in m) the length, breadth and height respectively. x , y and z are mode numbers of which only one can be zero. The lowest frequency at which a resonance can occur will be given by simply putting the two largest dimensions only into the above formula and equating their mode numbers to 1. For example, a climatic facility measuring 1,2 m by 1,0 m by 0,8 m will have a lowest resonance at:

$$f = 150 \sqrt{\left(\frac{1}{1,2}\right)^2 + \left(\frac{1}{1,0}\right)^2} = 195,26 \text{ MHz} \quad (5.2)$$

Resonances within, or close to, the frequency band of interest, are potential sources of measurement uncertainty since the Q-factor of a metallic chamber can produce extremely rapid changes of field intensity with frequency. In the presence of frequency drift (possibly due to battery run down, thermal effects, etc.) this can have a major impact on received signal levels. As an example, a measurement may be attempted at a frequency that happens to lie near the mid-point of one side of the resonance curve. As the generated frequency drifts or, alternatively, the frequency of resonance of the climatic facility changes (e.g. as a result of thermal expansion or contraction), the testing point will slide very quickly up or down the resonance curve as shown in figure 3.

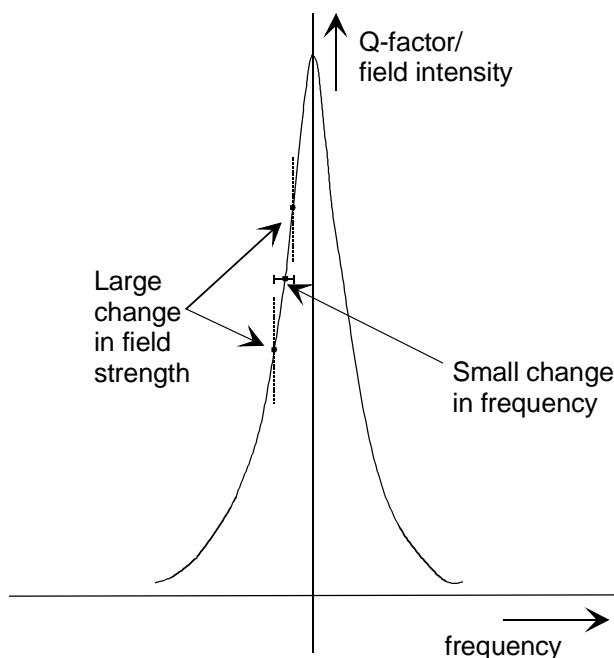

Figure 3: The effect of a small change in frequency on chamber Q-factor/field strength

Equally, during an adjacent channel selectivity test, should the nominal frequency (or one of the adjacent channels) coincide with a frequency of resonance, the true response of the EUT will be seriously masked by these potentially large variations in the field strength.

It is a good policy to calculate the likely frequencies of climatic facility resonances so as to avoid possible clashes with those at which testing will be carried out.

5.2.2 Internal reflections using a climatic facility

Multiple reflections, from the internal walls of a climatic facility, may seriously affect the uniformity of the field distribution. The magnitude of this effect becomes, in general, greater with increasing frequency. Where the wavelength of the test frequency is significantly shorter than the dimensions of the chamber, these reflections may result in numerous peaks and troughs in the generated fields. Should frequency drift occur during tests at these higher frequencies, with an EUT positioned close to a field null, then the drift in frequency may result in the null filling. A major change in the coupled signal level would then result. This could be reduced by using, for example, ferrite tiles (or grids) on the internal walls of the facility.

5.2.3 Mutual coupling effects using a climatic facility

Mutual coupling effects resulting from multiple imaging (again in the walls of the climatic facility) of the antenna/coupling device will change its input impedance, radiation pattern and gain. These effects tend to reduce with increasing frequency. In this case too, ferrite tiles (or grids) could reduce the uncertainty involved.

5.2.4 Waveguide-type modes within a climatic facility

In addition to resonance effects, a further problem that results from using metallic climatic facilities, is the possible propagation of transverse electric and transverse magnetic (waveguide-type) modes. These can be generated by a number of mechanisms, amongst which are the size and shape of the EUT and the materials from which it is made. These modes can only be supported when the cross-sectional dimensions of the metallic chamber exceed half a wavelength. Where it is of rectangular cross section with side lengths of a and b in m, the lowest frequencies at which these modes can propagate are given in MHz by:

$$f = 150 \sqrt{\left(\frac{m}{a}\right)^2 + \left(\frac{n}{b}\right)^2} \text{ MHz} \quad (5.3)$$

where m and n are mode numbers. For transverse magnetic modes, the lowest frequency possible requires both mode numbers to be equal to one, but for the transverse electric case, the lowest mode requires only one to be equal to one with the other zero. These modes can theoretically exist in any plane within the chamber that possesses a rectangular cross section. Such modes are not representative of performance in normal usage or when under test on either an Open Area Test Site or an Anechoic Chamber - they are simply a product of some launching mechanism within the test set-up and the boundary conditions of the "waveguide" formed by the test chamber.

5.2.5 Summary

To an extent, the overall effect on the performance of the EUT, produced by the climatic facility effect, is determined during the verification procedure. Its magnitude is used to determine whether the test fixture/climatic facility combination is acceptable.

u_{j61} is used for the uncertainty contribution associated with the climatic facility effect on the EUT as determined in the verification procedure.

6 Verification procedure for a test fixture

6.1 Definition

Field normalization

Field normalization is the process in which an EUT's performance on a free field test site is compared to its performance in a test fixture, both tests being carried out at the same verified free field test site under normal conditions of temperature and voltage.

6.2 Overview of the verification procedure

The verification procedure determines whether or not the test fixture has an unacceptably adverse effect on the EUT. An "adverse effect" could be the carrier frequency or receiver tuning being "pulled" to a higher or lower frequency, the output power level changing, etc. The end result of an adverse effect is a change in carrier frequency or effective radiated power (in the case of a transmitter) or maximum usable sensitivity (for a receiver).

A test fixture is always used in combination with a climatic facility for testing at extremes of temperature. As a result, a further part of the verification procedure is to determine whether the climatic facility has an adverse effect on the test fixture/EUT assembly.

The magnitude of any resulting level change determines the suitability of the test fixture - if the frequency shift exceeds 10 Hz or twice the assessed frequency stability (whichever is the greater) or if the level change (in either effective radiated power or maximum usable sensitivity tests) exceeds 1 dB, the test fixture is deemed not suitable.

The verification procedure for the test fixture associated with a **transmitting** device involves four steps.

- 1) the frequency error and effective radiated power of the transmitter (without the test fixture) are measured under normal conditions on an accredited free field test site (i.e. Open Area Test Site, Anechoic Chamber or Anechoic Chamber with a Ground Plane);
- 2) the transmitter is installed in the test fixture and the measurements in 1) repeated;
- 3) retaining the transmitter in the test fixture, the frequency and level of the signal appearing at the test fixture's 50 Ω RF connector are then measured;
- 4) the transmitter plus test fixture are then installed in the climatic facility and step 3) repeated.

The verification procedure for the test fixture associated with a **receiving** equipment involves exactly the same four steps, but the only measured parameter in this case is maximum usable sensitivity. In the final two steps, a modulated signal is fed into the test fixture's 50 Ω RF connector and a degradation measurement made.

To verify the test fixture associated with a **transceiver**, the procedures for both transmitter and receiver are carried out.

6.2.1 Apparatus required

The verification of a test fixture is carried out at an accredited free field test site using the test equipment listed in the relevant test method described in TR 102 273-2 [5], TR 102 273-3 [6] or TR 102 273-4 [7].

Additional apparatus required:

- 50 Ω load (type and sex of connector compatible with the test fixture RF port);
- Test Fixture;
- Climatic facility.

The type and serial numbers of all items of test equipment additional to those in the test method used in TR 102 273-2 [5], TR 102 273-3 [6] or TR 102 273-4 [7] should be recorded in the test fixture verification results sheet (see table 1).

6.2.2 Site preparation

The site preparation is the same as required in the relevant part of TR 102 273 for the free field test site. Additionally, for the test fixture, the cables supplying power to the EUT should be as short as possible, twisted together and loaded with ferrite beads spaced 0,15 m apart.

The RF cables should be routed by the shortest possible route, down through the turntable on a free field test site or down to, and out from, the climatic facility. Their entire lengths should also be loaded with ferrite beads spaced 0,15 m apart.

6.2.3 Measurement configuration

Testing on the free field test site involves measuring the same EUT parameter both with and without the test fixture. To reduce unnecessary measurement uncertainties, it is important that the EUT should be positioned in precisely the same place for both of these tests.

6.2.4 What to record

- A statement of the type of accredited free field test site used.
- The value of the measured parameter (effective radiated power, frequency or maximum usable sensitivity) on the accredited free field test site both before and after the inclusion of the test fixture.
- The value of the measured parameter (effective radiated power, frequency or maximum usable sensitivity) in the test fixture both before and after insertion in the climatic facility.
- Where clarification of a test method or an amended test procedure is required, this should be described in full.
- The EUT/Test Fixture assembly should be placed within the climatic facility in a repeatable position and this position should be recorded.

A results sheet is given in table 1.

6.3 Verification procedure

Introduction

The measured parameters in a verification procedure for the test fixture associated with a transmitting EUT differ to those for a receiving EUT. Consequently, separate procedures are given, the step numbers for the transmitter verification being preceded by a "T" whereas those for receivers are preceded by "R".

NOTE 1: For cases in which the EUT associated with the test fixture is a transceiver, both transmitter and receiver verification procedures should be carried out.

Method of measurement: Transmitter

- T1) Tests for frequency error and effective radiated power (without the test fixture) should be carried out on an accredited free field test site using the relevant test method in TR 102 273-2 [5], TR 102 273-3 [6] or TR 102 273-4 [7] for the stated polarization only. The measured parameters (frequency error in Hz and effective radiated power in dBm) should be recorded in the results sheet (see table 1).
- T2) The EUT should be installed in the test fixture with the RF port on the test fixture terminated by a 50 Ω load and Step T1 repeated for the EUT/Test Fixture assembly. The values of the measured parameters should again be entered in the results sheet (see table 1).

NOTE 2: In cases for which the new measured values differ **either** by more than 10 Hz in the frequency error test **or** by more than 0,5 dB in the effective radiated power test, from the values recorded in Step T1, the test fixture is deemed unsuitable and the verification procedure should be abandoned at this point.

- T3) The EUT should remain installed in the test fixture on the test site turntable. The frequency counter should be connected, via a 10 dB attenuator, to the external 50 Ω RF connector on the test fixture, replacing the 50 Ω load.

- T4) The EUT should be turned on without modulation and the reading on the frequency counter recorded in the results sheet (see table 1).

NOTE 3: For cases in which the frequency value recorded differs by more than 10 Hz from that recorded in Step T1, the test fixture is deemed unsuitable and the verification procedure should be abandoned at this point.

- T5) The receiving device should then be connected, via the same 10 dB attenuator, to the external 50 Ω RF connector on the test fixture, replacing the frequency counter. The EUT should be turned on without modulation and the received level (dBm) on the receiving device recorded in the results sheet (see table 1). The received level should be at least 20 dB above the ambient noise floor.

NOTE 4: For cases in which the received level is less than 20 dB above the ambient noise floor, the test fixture is deemed unsuitable and the verification procedure should be abandoned at this point.

- T6) The EUT/ test fixture assembly should be removed from the test site and placed inside the climatic facility in which normal conditions (as defined in the relevant standard) exist. The position of the test fixture within the climatic facility should be recorded in the results sheet (see table 1). The test fixture should be connected to power supplies and to the frequency counter as shown in figure 4.

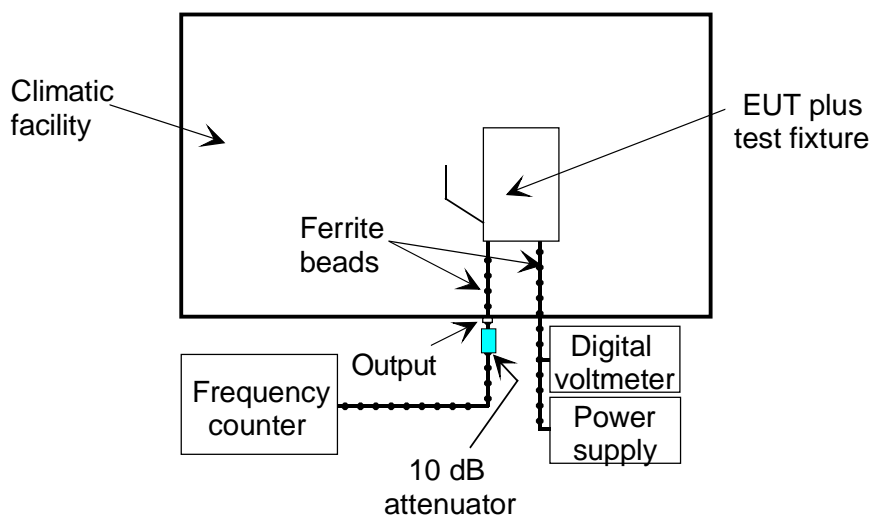

Figure 4: Set-up for Frequency error measurement using a test fixture

- T7) The EUT should be turned on without modulation and the reading on the frequency counter recorded in the results sheet (see table 1).

NOTE 5: For cases in which the frequency value recorded differs by more than 10 Hz from that recorded in Step T1, the test fixture/climatic facility combination is deemed unsuitable and the verification procedure should be abandoned at this point.

T8) The receiving device should then be connected in place of the frequency counter, the EUT should be turned on without modulation and the received level (dBm) on the receiving device recorded in the results sheet (see table 1).

NOTE 6: After correction for the loss of any cables or attenuators placed between the test fixture output and the receiving device, if the received level should differ by more than 0,5 dB from the value recorded in Step T5, the test fixture/Climatic facility combination is deemed unsuitable.

Method of measurement: Receiver

R1) A maximum usable sensitivity test (using the relevant modulation for analogue speech, bit stream or messages) without the test fixture should be carried out on a free field test site using the relevant test method in TR 102 273-2 [5], TR 102 273-3 [6] or TR 102 273-4 [7] for the stated polarization only. The measured value of maximum usable sensitivity in $\mu\text{V}/\text{m}$ should be recorded in the results sheet (see table 1).

R2) The EUT should be installed in the test fixture with the RF port on the test fixture terminated by a $50\ \Omega$ load and Step R1 repeated. The new value of the maximum usable sensitivity should again be entered in the results sheet (see table 1).

NOTE 7: In cases for which the new measured value differs by more than 0,5 dB from the value recorded in Step R1, the test fixture is deemed unsuitable and the verification procedure should be abandoned at this point.

R3) The EUT should remain installed in the test fixture on the test site turntable. The signal generator should be connected, via a 10 dB attenuator, to the external $50\ \Omega$ RF connector on the test fixture, replacing the $50\ \Omega$ load.

R4) The signal generator output should be modulated by the appropriate modulation and adjusted to a level of 50 dB above the maximum usable sensitivity level recorded in Step R2 above. The EUT should be switched on and its response to the test signal observed.

NOTE 8: If the EUT does not respond, the test fixture is deemed unsuitable and the verification procedure should be abandoned at this point.

R5) The signal generator output level should be adjusted to find the minimum level at which the EUT responds to the test signal. This signal generator output level (dBm), after correction to account for the losses in the RF cabling and the 10 dB attenuator, should be recorded in the results sheet (see table 1).

R6) The EUT/Test Fixture assembly should then be removed from the test site and placed inside the climatic facility in which normal conditions (as defined in the relevant standard) exist. The position of the Test Fixture within the climatic facility should be recorded in the results sheet (see table 1). The test fixture should be connected to power supplies and to the signal generator as shown in figure 5.

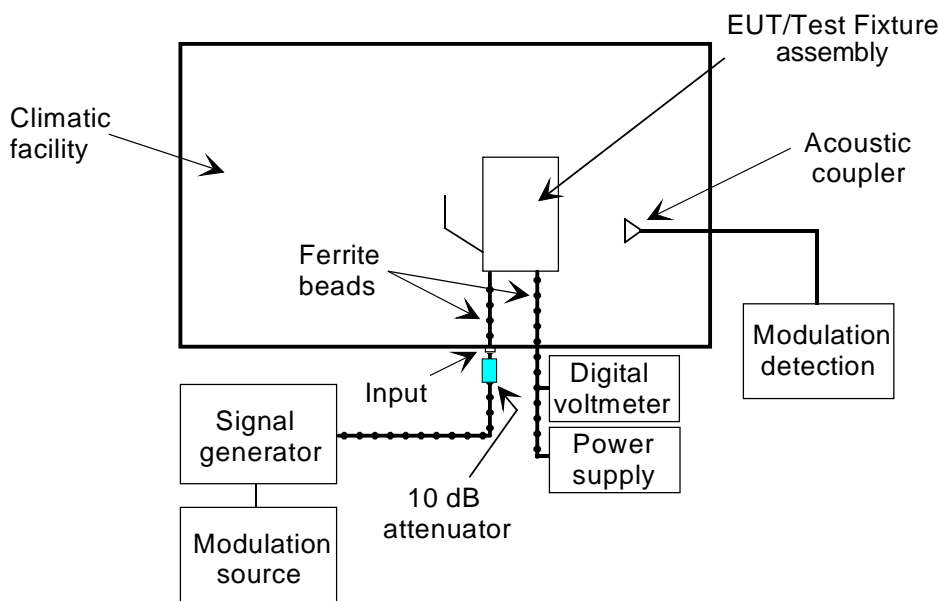

Figure 5: Set-up for maximum usable sensitivity using a test fixture (shown with acoustic coupler)

- R7) The signal generator output should be modulated by the appropriate modulation and adjusted to find the minimum level at which the EUT responds to the test signal. This signal generator output level (dBm), after correction to account for the losses in the RF cabling and the 10 dB attenuator, should be recorded in the results sheet (see table 1).

NOTE 9: In cases for which the new measured value differs by more than 0,5 dB from the value recorded in Step R5, the test fixture/climatic facility combination is deemed not suitable for use.

Method of measurement: Transceiver

The procedure for the verification of a test fixture (and an associated climatic facility) for a transceiver comprises both the full procedures for a transmitter and a receiver. There may be some change in the order of the procedure steps (it would be inefficient to complete steps T1 to T8 and then follow with steps R1 to R7) so that, for example, all tests on the test site are performed together, followed by performing all the tests in the climatic facility together. All steps should be carried out however.

Table 1: test fixture verification results sheet

Test Fixture verification procedure results sheet							PAGE 1 of 1	
EUT:		Type No:		Serial No:		Date:		
Nominal frequency (MHz):		Free field test site type:						
TRANSMITTER TESTS								
Configuration								
Test	Free field test site: No test fixture		Free field test site: In the test fixture		Test site turntable: In the test fixture		Climatic facility: In the test fixture	
	Step	Value	Step	Value	Step	Value	Step	Value
Frequency error	T1		T2		T4		T7	
Effective radiated power	T1		T2		T5		T8	
RECEIVER TEST								
Configuration								
Test	Free field test site: No test fixture		Free field test site: In the test fixture		Test site turntable: In the test fixture		Climatic facility: In the test fixture	
	Step	Value	Step	Value	Step	Value	Step	Value
Maximum usable sensitivity	R1		R2		R5		R7	
Mounting configuration in the climatic facility								
Test Fixture:			10 dB attenuator:					
RF cable 1:			50 Ω load:					
RF cable 2:			Climatic facility:					
RF cable 3:			Signal generator (if applicable):					
Receiving device (if applicable):			Frequency counter (if applicable):					
Ferrite type:			Ferrite manufacturer:					

6.4 Processing the results of the verification procedure

The only necessary processing of the results is performed during the method of measurement. Specifically, at each stage of the procedure (after Steps T1 and R1) in which a measurement is taken, this is compared to an earlier result. If at each of these stages the new measurement satisfies the stated condition, the procedure continues. On completion of the procedure (with all conditions satisfied), the test fixture and the climatic facility are deemed suitable for test purposes and no further processing of the results is necessary.

6.5 Calculation of measurement uncertainty

For the first two measurements of both transmitter and receiver verification procedures, the measurement uncertainty is calculated in the course of the test method (taken from TR 102 273-2 [5], TR 102 273-3 [6] or TR 102 273-4 [7]). Consequently, the various contributory components to the overall uncertainty of these two measurements will have been fully evaluated in the method.

For the final two measurements, namely the coupling of the test fixture to the EUT both inside and outside the climatic facility, the measurement uncertainty is unimportant since:

- the tolerable margin of error in the verification procedure is very wide (essentially the procedure only determines whether there is any coupling between the test fixture and the EUT);
- the test fixture, in final use, only provides relative results - results which are relative to its own value under normal conditions.

7 Test methods

7.1 Introduction

The following test methods apply to integral antenna devices only i.e. EUTs not fitted with either a permanent or a temporary external antenna connector.

The test fixture should be supplied by the manufacturer of the EUT and should enable testing to be performed under extreme test conditions of temperature and/or voltage, as defined in the relevant standard. It should provide RF connection(s) and allow connection(s) to external power supply(s) and control equipment if necessary.

Tests such as adjacent channel power and certain receiver parameters are, for integral antenna devices, usually only performed in a test fixture. In these cases the measurement result under normal conditions is directly related to either the effective radiated power (for the case of adjacent channel power testing) or to maximum usable receiver sensitivity (for a receiver parameter) measured on an accredited free field test site.

7.1.1 Site preparation

Prior to any tests in the test fixture, the following preparation should be carried out.

Calibration data for all items of test equipment should be available and valid. The calibration data on all RF cables used should include insertion loss and VSWR throughout the entire frequency range of the tests.

Where correction factors/tables are required, these should be immediately available.

For all items of test equipment, the maximum uncertainties they exhibit should be known along with the distribution of the error, e.g.:

- cable loss: $\pm 0,5$ dB with a rectangular distribution;
- measuring receiver: 1,0 dB (standard deviation) signal level accuracy with a Gaussian error distribution.

For the particular EUT, the corresponding results of the verification of the test fixture taken at an accredited free field test site i.e. Open Area Test Site, Anechoic Chamber or Anechoic Chamber with a Ground Plane should be available. These results should have been taken under normal conditions in full accordance with the test methods described in the relevant part of TR 102 273 and should include the associated measurement uncertainty values.

Test Fixtures are always used in conjunction with climatic facilities, within which the RF cabling should be kept as short as possible. The RF cables should be routed by the shortest possible means down to, and out from, the climatic facility. Their entire lengths should also be loaded with ferrite beads spaced 0,15 m apart. The power supply cable(s) should also be as short as possible, twisted together and loaded with ferrite beads spaced 0,15 m apart.

At the start of each day, system checks should be made on the test equipment used in the following test methods. The following checking procedures, as a minimum requirement, should be carried out.

- 1) All items of test equipment should be connected to their respective power supplies, switched on and allowed adequate time to stabilize, as recommended by their manufacturers. Where a sterilization period is not given by the manufacturer, 30 minutes should be allowed. After this time period those items of test equipment which possess the facility, should have their self test/self calibration procedures performed.
- 2) A network analyser should be connected to the 50 Ω connector of the test fixture and a measurement made of its input VSWR. The measurement should be taken across a frequency band which extends 10 MHz either side of the nominal frequency of the EUT for which the test fixture has been supplied. The results of the test should be compared to previous results. Any anomalies should be investigated.

7.1.2 Preparation of the EUT

The manufacturer should supply information about the EUT covering the operating frequency, polarization, supply voltage(s) and the reference face. Additional information, specific to the type of EUT should include, where relevant, carrier power, channel spacing, whether different operating modes are available (e.g. high and low power modes) and if it operates continuously or is subject to a maximum test duty cycle (e.g. one minute on, four minutes off).

The presence of the cables supplying power can affect the measured performance of the EUT. For this reason, attempts should be made to make them "transparent" as far as the testing is concerned. This can be achieved by routing them by the shortest possible paths down to, and out from the climatic facility. Additionally, where possible, these leads should be twisted together and loaded with ferrite beads at 0,15 m spacing.

7.1.3 Power supplies to the EUT

All tests should be performed using power supplies wherever possible, including tests on EUT designed for battery-only use. In all cases, power leads should be connected to the EUTs supply terminals (and monitored with a digital voltmeter) but the battery should remain present, electrically isolated from the rest of the equipment, possibly by putting tape over its contacts. All leads involved should be routed and dressed as described in clause 7.1.2.

7.2 Transmitter tests

7.2.1 Frequency error (30 MHz to 1 000 MHz)

Definition

The frequency error of a transmitter is the difference between the measured carrier frequency in the absence of modulation and the nominal frequency of the transmitter as stated by the manufacturer.

7.2.1.1 Apparatus required

- Digital voltmeter.
- Ferrite beads.
- 10 dB attenuator.
- Power supply.
- Connecting cables.
- Test Fixture.
- Climatic facility.
- Accredited free field test site.
- Frequency counter.

The type and serial numbers of all items of test equipment should be recorded in the log book results sheet (see table 2).

7.2.1.2 Method of measurement

- 1) The measurement should always be performed in the absence of modulation.
- 2) The test fixture should have been verified for use, with the particular EUT, on an accredited free field test site in accordance with clause 6. Four different measurements of the magnitude of the frequency error should have been taken during the verification, each corresponding to a different configuration of the EUT, namely:
 - a) the EUT by itself on the accredited free field test site;
 - b) the EUT secured in the test fixture, again on the accredited free field test site;
 - c) the frequency presented at the test fixture's RF connector with the test fixture/EUT assembly on the accredited free field test site;
 - d) the frequency presented at the test fixture's RF connector with the test fixture/EUT assembly in the climatic facility.
- 3) The EUT should still be secured in the test fixture and the test fixture/EUT assembly should be placed in the climatic facility in a repeatable position. This mounting configuration should be noted in the log book results sheet (see table 2).
- 4) The assembly should be connected to the test equipment as shown in figure 6.
- 5) Normal conditions (as defined in the relevant testing standard) should exist within the climatic facility.
- 6) The EUT should be turned on without modulation, allowed adequate time to stabilize and the resolution of the frequency counter adjusted to read to the nearest Hz.
- 7) The value of the frequency displayed on the counter should be recorded in the log book results sheet (see table 2).

NOTE 1: In cases where the frequency does not appear stable, this step might require observations over a 30 second or 1 minute time period, noting the highest and lowest readings and estimating the average value. In these cases it is the average value that should be recorded in the log book results sheet (see table 2).

- 8) The EUT and its power supplies should then be switched off and the climatic facility programmed to provide the upper extreme of temperature.
- 9) The climatic facility should be allowed adequate time at the extreme condition for all components to settle to the temperature required. Steps 6 and 7 should then be repeated.

NOTE 2: For tests at extreme conditions, the relevant standard will specify the extreme temperatures and voltages to apply, along with stabilization and operating periods which should both be completed before any measurements are carried out.

NOTE 3: To avoid thermally shocking the EUT, it is recommended that the rates of change of temperature should not exceed 1°C per minute. The preferred rate of change of temperature is 0,33°C per minute.

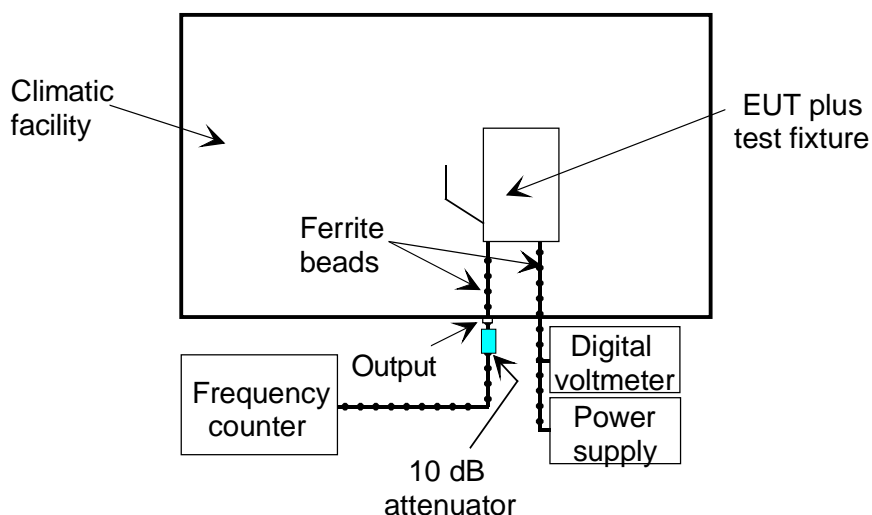

Figure 6: Set-up for frequency error measurement using a test fixture

- 10) The supply voltage to the EUT should be set to the upper extreme as given in the relevant testing standard. Steps 6 and 7 should then be repeated.
 - 11) The supply voltage to the EUT should then be set to the lower extreme as given in the relevant testing standard. Steps 6 and 7 should then be repeated.
 - 12) The EUT and its power supplies should then be switched off and the climatic facility programmed to provide the lower extreme of temperature.
 - 13) The climatic facility should be allowed adequate time at the extreme temperature condition for all components to settle to the temperature required.
- NOTE 4: For tests at extreme conditions, the relevant testing standard will specify the extreme temperatures and voltages to apply, along with sterilization and operating periods which should both be completed before any measurements are carried out.
- NOTE 5: To avoid thermally shocking the EUT, it is recommended that the rates of change of temperature should not exceed 1°C per minute. The preferred rate of change of temperature is 0,33°C per minute.
- 14) The supply voltage to the EUT should be set to the lower extreme as given in the relevant testing standard. Steps 6 and 7 should then be repeated.
 - 15) The supply voltage to the EUT should then be set to the upper extreme as given in the relevant testing standard. Steps 6 and 7 should then be repeated.
 - 16) On completion of the extreme conditions, the climatic facility should be returned to the normal condition.

7.2.1.3 Procedure for completion of the results sheets

There are two values that need to be derived before the overall results sheet (see table 3) can be completed. Firstly the value for frequency error (from a straightforward calculation of recorded frequency minus the nominal frequency) and secondly, the value of the expanded uncertainty for the test which should be calculated in accordance with clause 7.2.2.

7.2.1.4 Log book entries

Table 2: Log book results sheet

FREQUENCY ERROR			Date:	PAGE 1 of 1	
Frequency:.....MHz		Free-field test site type:.....			
Manufacturer of EUT:.....		Type number:.....		Serial No:.....	
Test equipment item	Type No.	Serial No.	VSWR	Insertion loss	
Digital voltmeter			N/A	N/A	
Power supply			N/A	N/A	
Ferrite beads (for RF cables)			N/A	N/A	
Ferrite beads (for power cables)			N/A	N/A	
10 dB attenuator					
RF cable to frequency counter input					
RF cable within climatic facility					
Climatic facility			N/A	N/A	
Accredited free field test site			N/A	N/A	
Frequency counter				N/A	
Mounting configuration in the climatic facility					
	T (normal)	T (high)		T (low)	
	V (normal)	V (high)	V (low)	V (high)	V (low)
Reading on frequency counter	Hz	Hz	Hz	Hz	Hz

7.2.1.5 Statement of results

The results are presented in tabular form as shown in table 3.

Table 3: Overall results sheet

FREQUENCY ERROR			Date:	PAGE 1 of 1	
	T (normal)	T (high)		T (low)	
	V (normal)	V (high)	V (low)	V (high)	V (low)
Frequency error	Hz	Hz	Hz	Hz	Hz
Expanded uncertainty (95 %)	Hz				

7.2.2 Expanded uncertainty for frequency error test

The method of calculating the expanded uncertainty for tests in which signal levels in dB are involved is equally adopted for the frequency error test in which all the uncertainties are in the units of Hz. That is, all the uncertainty contributions are converted into standard uncertainties and combined by the RSS method under the assumption that they are all stochastic. All the uncertainty components which contribute to the test are listed in table 4. Annex A should be consulted for the sources and/or magnitudes of the uncertainty contributions.

Table 4: Contributions from the measurement

$u_{j\ or\ i}$	Description of uncertainty contributions	Hz
u_{j01}	random uncertainty (see note in clause A.18 of TR 102 273-1-2 and note in clause 6.4.7 of TR 102 273-1-1)	
u_{j56}	frequency counter: absolute reading	
u_{j60}	Test Fixture: effect on the EUT	
u_{j61}	Test Fixture: climatic facility effect on the EUT	

The standard uncertainties from table 4 should be combined by RSS in accordance with TR 102 273-1-1 [4]. The combined standard uncertainty of the frequency measurement (u_c contributions from the measurement) is the combination of the components outlined above.

u_c = uc contributions from the measurement = __, __ Hz

The expanded uncertainty is $\pm 1,96 \times u_c = \pm$ __, __ Hz at a 95 % confidence level.

7.2.3 Effective radiated power (30 MHz to 1 000 MHz)

Definition

The effective radiated power is the power radiated in the direction of the maximum field strength under specified conditions of measurement, in the absence of modulation.

7.2.3.1 Apparatus required

- Digital voltmeter.
- Ferrite beads.
- 10 dB attenuator.
- Power supply.
- Connecting cables.
- Test Fixture.
- Climatic facility.
- Accredited free field test site.
- Receiving device (measuring receiver or spectrum analyser).

The type and serial numbers of all items of test equipment should be recorded in the log book results sheet (see table 5).

7.2.3.2 Method of measurement

- 1) The measurement should always be performed in the absence of modulation.
- 2) The test fixture should have been verified for use, with the particular type of EUT, on an accredited free field test site in accordance with clause 6. Four different measurements of the value of effective radiated power should have been taken during the verification, each corresponding to a different configuration of the EUT, namely:
 - a) the EUT by itself on the accredited free field test site;
 - b) the EUT secured in the test fixture, again on the accredited free field test site;
 - c) the power measured at the test fixture's RF connector with the test fixture/EUT assembly on the accredited free field test site;

- d) the power measured at the test fixture's RF connector with the test fixture/EUT assembly in the climatic facility.

The value recorded for configuration b) during the verification procedure should be entered in the log book results sheet (see table 5).

- 3) The EUT should still be secured in the test fixture and the test fixture/EUT assembly should be placed in the climatic facility in a repeatable position. This position should be recorded in the log book results sheet (see table 5).
- 4) The test fixture/EUT assembly should be connected to the test equipment as shown in figure 7.
- 5) Normal conditions (as defined in the relevant testing standard) should exist within the climatic facility.
- 6) The EUT should be switched on without modulation, allowed time to stabilize and the receiving device tuned to the appropriate frequency.
- 7) The signal level detected on the receiving device should be recorded (dBm) in the log book results sheet (see table 5).
- 8) The EUT and its power supplies should then be switched off and the climatic facility programmed to provide the upper extreme of temperature.
- 9) The climatic facility should be allowed adequate time at the extreme temperature condition for all components to settle to the temperature required.

NOTE 1: For tests at extreme conditions, the relevant Standard will specify the extreme temperatures and voltages to apply, along with sterilization and operating periods which should both be completed before any measurements are carried out.

NOTE 2: To avoid thermally shocking the EUT, it is recommended that the rates of change of temperature should not exceed 1°C per minute. The preferred rate of change of temperature is 0,33°C per minute.

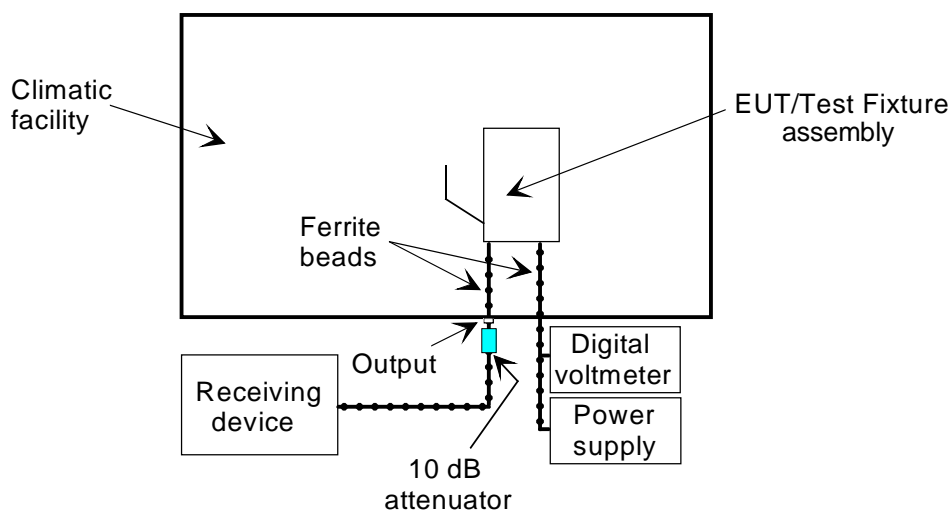

Figure 7: Set-up for Effective radiated power measurement using a test fixture

- 10) The EUT should be switched on and its supply voltage should be set to the upper extreme as given in the relevant testing standard. Step 7 should then be repeated.
- 11) The supply voltage to the EUT should then be set to the lower extreme as given in the relevant testing standard. Step 7 should then be repeated.
- 12) The EUT and its power supplies should then be switched off and the climatic facility programmed to provide the lower extreme of temperature.
- 13) The climatic facility should be allowed adequate time at the extreme temperature condition for all components to settle to the temperature required.

NOTE 3: For tests at extreme conditions, the relevant testing standard will specify the extreme temperatures and voltages to apply, along with stabilization and operating periods which should both be completed before any measurements are carried out.

NOTE 4: To avoid thermally shocking the EUT, it is recommended that the rates of change of temperature should not exceed 1°C per minute. The preferred rate of change of temperature is 0,33°C per minute.

14) The EUT should be switched on and its supply voltage should be set to the lower extreme as given in the relevant testing standard. Step 7 should then be repeated.

15) The supply voltage to the EUT should then be set to the upper extreme as given in the relevant testing standard. Step 7 should then be repeated.

16) On completion of the extreme conditions, the climatic facility should be returned to the normal condition.

7.2.3.3 Procedure for the completion of the results sheets

Because the measurement of effective radiated power in a test fixture is a relative measurement with all circuit components remaining present during all the tests, no corrections to measured values are required.

However, a calculation does have to be performed within the overall results sheet (see table 6) in order to relate the measured values of received signal level to the effective radiated power measurement on the accredited free field test site. For each value of received signal level measured in this procedure, the effective radiated power is derived by adding to it the difference between the accredited free field test site value and the received signal level in the climatic facility under normal conditions of both temperature and voltage i.e.:

$$\begin{aligned} \text{effective radiated power for } T(), V() &= \text{received signal level for } T(), V() \\ &+ \text{effective radiated power on accredited free field test site for } T(n), V(n) \\ &- \text{received signal level for } T(\text{normal}), V(\text{normal}) \end{aligned}$$

The final value that needs to be derived for inclusion in the overall results sheet (see table 6) is the expanded measurement uncertainty. This should be calculated in accordance with clause 7.2.4.

7.2.3.4 Log book entries

Table 5: Log book results sheet

EFFECTIVE RADIATED POWER				Date:	PAGE 1 of 2
Temperature:.....°C		Humidity:.....%		Frequency:.....MHz	
Manufacturer of EUT:.....		Type No:.....		Serial No:.....	
Bandwidth of Receiving Device.....Hz					
Test equipment item	Type No.	Serial No.	VSWR	Insertion loss	
Digital voltmeter			N/A	N/A	
Power supply			N/A	N/A	
Ferrite beads (for RF cables)			N/A	N/A	
Ferrite beads (for power cables)			N/A	N/A	
10 dB attenuator					
RF cable to receiver input					
RF cable within climatic facility					
Climatic facility			N/A	N/A	
Accredited free field test site			N/A	N/A	
Receiving device				N/A	
Result of measurement on accredited free field test site:					
Type of test site:.....					
Effective radiated power (dBm):.....					
Mounting configuration of EUT					
		Temperature/Voltage			
		T(normal)	T(high)	T(low)	
		V(normal)	V(high)	V(low)	V(low)
Received signal level	dBm				

7.2.3.5 Statement of results

The results are presented in tabular form as shown in table 6.

Table 6: Overall results sheet

EFFECTIVE RADIATED POWER				Date:	PAGE 1 of 1
Temperature/Voltage					
		T(normal)	T(high)	T(low)	
		V(normal)	V(high)	V(low)	V(low)
Effective radiated power	dBm				
Expanded uncertainty (95 %)					dB

7.2.4 Uncertainty for effective radiated power measurement

All the uncertainty contributions for the test are listed in table 7.

Table 7: Contributions from the measurement

$u_{j \text{ or } i}$	Description of uncertainty contributions	dB
u_{j48}	receiving device: linearity	
u_{j50}	EUT: influence of the ambient temperature on the ERP of the carrier	
u_{j53}	EUT: influence of setting the power supply on the ERP of the carrier	
u_{j60}	Test Fixture: effect on the EUT	
u_{j61}	Test Fixture: climatic facility effect on the EUT	
u_{j01}	random uncertainty (see note in clause A.18 of TR 102 273-1-2 and note in clause 6.4.7 of TR 102 273-1-1)	

The standard uncertainties from table 7 should be given values according to annex A of TR 102 273-1-1 [4]. This gives the combined standard uncertainty (u_c contributions from the measurement) for the EUT measurement in dB.

7.2.4.1 Expanded uncertainty for Effective radiated power measurement

Tests in a test fixture differ to radiated tests on all other types of site in that there is only one stage to the test. However, to calculate the measurement uncertainty, the test fixture measurement should be considered as stage two of a test in which stage one was on an accredited free field test site. The combined standard uncertainty, u_c , of the effective radiated power measurement is therefore, simply the RSS combination of the value for u_c contributions from the measurement derived above and the combined uncertainty of the free field test site u_c contribution from the free field test site

$$u_c = \sqrt{u_{c \text{ contributions from the measurement}}^2 + u_{c \text{ contributions from the free-field test site}}^2} = \dots, \dots \text{ dB} \quad (7.1)$$

The expanded uncertainty is $\pm 1,96 \times u_c = \pm \dots, \dots$ dB at a 95 % confidence level.

7.2.5 Spurious emissions (30 MHz to 4 GHz or 12,75 GHz)

This test is not carried out in a test fixture.

7.2.6 Adjacent channel power (30 MHz to 1 000 MHz)

Definition

The adjacent channel power is that part of the total power output of a transmitter under defined conditions of modulation, which falls within a specified passband centred on the nominal frequency of either of the adjacent channels. This power is the sum of the mean power produced by the modulation, hum and noise of the transmitter.

It is specified either as the ratio expressed in decibels of the carrier power to the adjacent channel power or as an absolute value.

7.2.6.1 Apparatus required

- Digital voltmeter;
- Ferrite beads;
- 10 dB attenuator;
- Power supply;
- Connecting cables;
- Test Fixture;

- Climatic facility;
- Accredited free field test site;
- Power measuring receiver (as defined in TR 100 027 [3]).

Additional requirements for analogue speech:

- AF source;
- SINAD meter (incorporating telephone psophometric weighting network);
- Acoustic coupler (alternatively: audio load).

Additional requirements for bit stream:

- Bit stream generator;
- Bit error measuring test set.

Additional requirements for messages:

- Acoustic coupler;
- Message generator;
- Response measuring test set.

The type and serial numbers of all items of test equipment should be recorded on page 1 of the log book results sheet (see table 9).

7.2.6.2 Method of measurement

NOTE 1: In the following test method, an adjacent channel power meter is assumed. For cases in which a spectrum analyser is used, appropriate changes to the method, results and calculations should be made.

- 1) The test fixture should have been verified for use, with the particular type of EUT, on an accredited free field test site in accordance with clause 6. Four different measurements of the value of effective radiated power should have been taken during the verification, each corresponding to a different configuration of the EUT, namely:
 - a) the EUT by itself on the accredited free field test site;
 - b) the EUT secured in the test fixture, again on the accredited free field test site;
 - c) the power measured at the test fixture's RF connector with the test fixture/EUT assembly on the accredited free field test site;
 - d) the power measured at the test fixture's RF connector with the test fixture/EUT assembly in the climatic facility.

The value recorded for configuration b) during the verification procedure should be entered in the log book results sheet (see table 9).

- 2) The EUT should still be secured in the test fixture and the test fixture/EUT assembly should be placed in the climatic facility in a repeatable position. This position should be noted in the log book results sheet (see table 9).
- 3) The EUT/Test Fixture assembly should be connected to the test equipment as shown in figure 8.

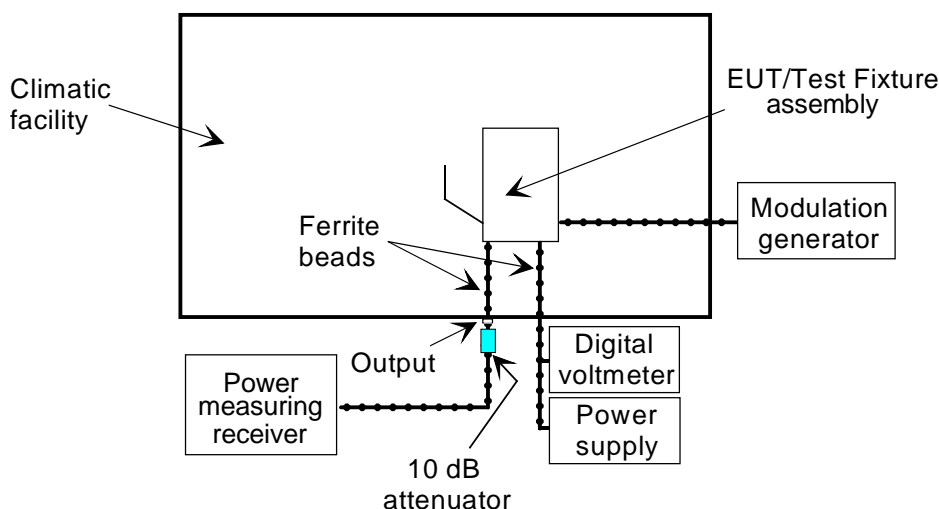

Figure 8: Set-up for adjacent channel power test using a test fixture

- 4) Normal conditions (as stated in the relevant testing standard) should exist within the climatic facility.
- 5) The EUT should be switched on without modulation, allowed time to stabilize and the power measuring receiver tuned so that the maximum response is obtained. The level of the response (dBm) and the setting of the input attenuator (dB) should be recorded on page 2 of the log book results sheet (see table 9).
- 6) Retaining the unmodulated transmitter, the tuning of the power measuring receiver should be adjusted away from the carrier so that its -6 dB response nearest to the transmitter carrier frequency is located at a displacement from the *nominal frequency* of the carrier as given in table 8.

Table 8: Frequency displacement

Channel separation (kHz)	Displacement (kHz)
12,5	8,25
20	13
25	17

NOTE 2: The same result may be obtained by tuning the power measuring receiver to the *nominal frequency* of the adjacent channel, if it has been suitably calibrated.

- 7) Modulation should be applied to the transmitter under test as follows, depending on whether the test is for analogue speech, bit stream or messages.

For analogue speech:

- the transmitter should be modulated with a 1 250 Hz tone at a level which is 20 dB higher than that required to produce normal deviation.

For bit stream:

- the transmitter should be modulated with the test modulation D-M2 at a deviation of 12 % of the channel spacing.

For messages:

- the transmitter should be modulated with the test modulation D-M3 repeated continuously at a deviation of 12 % of the channel spacing.

- 8) The variable attenuator on the power measuring receiver should be adjusted until the same reading (or a known relation to it) as obtained in Step 5 is observed. The signal level and the setting of the input attenuator should be recorded on page 2 of the log book results sheet (see table 9).

- 9) Steps 6, 7 and 8 should be repeated for the power measuring receiver tuned to the other side of the carrier frequency.
- 10) The EUT/Test Fixture assembly power supplies should then be switched off and the climatic facility programmed to provide the upper extreme of temperature.
- 11) The climatic facility should be allowed adequate time at the extreme condition for all components to settle to the temperature required.
- NOTE 3: For tests at extreme conditions, the relevant testing standard will specify the extreme temperatures and voltages to apply, along with stabilization and operating periods which should both be completed before any measurements are carried out.
- NOTE 4: To avoid thermally shocking the EUT, it is recommended that the rates of change of temperature should not exceed 1°C per minute. The preferred rate of change of temperature is 0,33°C per minute.
- 12) The supply voltage to the EUT should be set to the upper extreme as given in the relevant testing standard. Steps 5, 6, 7, 8 and 9 should then be repeated.
- 13) The supply voltage to the EUT should then be set to the lower extreme as given in the relevant testing standard. Steps 6, 7, 8 and 9 should then be repeated.
- 14) The EUT/Test Fixture assembly power supplies should then be switched off and the climatic facility programmed to provide the lower extreme of temperature.
- 15) The climatic facility should be allowed adequate time at the extreme temperature condition for all components to settle to the temperature required.
- NOTE 5: For tests at extreme conditions, the relevant testing standard will specify the extreme temperatures and voltages to apply, along with stabilization and operating periods which should both be completed before any measurements are carried out.
- NOTE 6: To avoid thermally shocking the EUT, it is recommended that the rates of change of temperature should not exceed 1°C per minute. The preferred rate of change of temperature is 0,33°C per minute.
- 16) The supply voltage to the EUT should be set to the lower extreme as given in the relevant testing standard. Steps 5, 6, 7, 8 and 9 should then be repeated.
- 17) The supply voltage to the EUT should then be set to the upper extreme as given in the relevant testing standard. Steps 6, 7, 8, 9 and 10 should then be repeated.
- 18) On completion of the extreme conditions, the climatic facility should be returned to the normal condition.

7.2.6.3 Procedure for completion of the results sheets

At the end of the test method, the log book results sheet (see table 9) will be complete apart from entries in the 15 "Overall level" cells. These are calculated by adding the received power level to the attenuator setting for the particular frequency of test.

NOTE: The attenuator setting is always to be taken as positive (i.e. > 0) dB.

The "Adjacent channel power" cells in the overall results sheet (see table 10) can then be completed by subtracting the adjacent channel "Overall level" cells from the carrier frequency "Overall level" cells (for the same values of temperature and voltage) on page 2 of the log book results sheet (see table 9).

There are no correction factors involved in this test, since the adjacent channel power figures are derived from an entirely relative test in which all test components (i.e. cables, adapters, modulation source, attenuator, power measuring receiver, frequency, etc.) remain unchanged.

Some testing standards require that the adjacent channel power is given in absolute power terms. For these cases, the relative (i.e. dB) results for the adjacent channel power have to be referenced to the accredited free field test site result for effective radiated power. The absolute values are derived by subtraction of the relative values from the accredited free field test site value.

The final value that needs to be calculated in order to complete the overall results sheet (see table 10) is that of the expanded uncertainty for the test. This should be calculated in accordance with clause 7.2.7.

7.2.6.4 Log book entries

Table 9: Log book results sheet

ADJACENT CHANNEL POWER TEST		Date:	PAGE 1 of 2	
Temperature:.....°C		Humidity:.....%	Frequency:.....MHz	
Bandwidth of Receiving Device:.....Hz		Manufacturer of EUT:..... Type No:..... Serial No:.....		
Test equipment item	Type No.	Serial No.	VSWR	Insertion loss
Digital voltmeter			N/A	N/A
Power supply			N/A	N/A
Ferrite beads (for RF cables)			N/A	N/A
Ferrite beads (for power cables)			N/A	N/A
10 dB attenuator				
Receiver cable				
RF cable within climatic facility				
Climatic facility			N/A	N/A
Accredited free field test site			N/A	N/A
Power measuring receiver				N/A
AF source (if applicable)			N/A	N/A
SINAD meter (if applicable)				
Audio load (if applicable)				
Bit stream generator (if applicable)			N/A	N/A
Bit error measuring test set (if applicable)				
Acoustic coupler (if applicable)				
Message generator (if applicable)			N/A	N/A
Response measuring test set (if applicable)				
Result of measurement on accredited free field test site:				
Type of test site:.....				
Effective radiated power (dBm):.....				
Mounting configuration of EUT				

ADJACENT CHANNEL POWER TEST			Date:	PAGE 1 of 2		
Frequency	Temperature:	T(normal)	T(high)		T(low)	
	Voltage:	V(normal)	V(high)	V(low)	V(high)	V(low)
	Received signal level (dBm):					
Carrier	Attenuator setting (dB):					
	Overall level (i.e. received signal level + attenuator setting) dBm:					
Adjacent	Received signal level (dBm):					
channel	Attenuator setting (dB):					
(LOW)	Overall level (i.e. received signal level + attenuator setting) dBm:					
Adjacent	Received signal level (dBm):					
channel	Attenuator setting (dB):					
(HIGH)	Overall level (i.e. received signal level + attenuator setting) dBm:					

7.2.6.5 Statement of results

The results are presented in tabular form as shown in table 10.

Table 10: Overall results sheet

ADJACENT CHANNEL POWER TEST			Date:	PAGE 1 of 1		
Temperature:	T(normal)	T(high)		T(low)		
Voltage:	V(normal)	V(high)	V(low)	V(high)	V(low)	
Adjacent channel power (LOW): dB						
Adjacent channel power (HIGH): dB						
Expanded uncertainty (95 %)						dB

NOTE: Some standards require the adjacent channel power to be 60 dBc without the need for it to fall below 250 nW. In this case, both values (dBc and absolute) are required as, for example, 40 dBc is considered satisfactory if the adjacent channel power is less than 250 nW.

7.2.7 Measurement uncertainty for Adjacent channel power

All the uncertainty contributions for the test are listed in table 11.

Table 11: Contributions from the measurement

$u_{j \text{ or } i}$	Description of uncertainty contributions	dB
u_{j48}	receiving device: linearity	
u_{j49}	receiving device: power measuring receiver	
u_{j50}	EUT: influence of the ambient temperature on the ERP of the carrier	
u_{j53}	EUT: influence of setting the power supply on the ERP of the carrier	
u_{j60}	Test Fixture: effect on the EUT	
u_{j61}	Test Fixture: climatic facility effect on the EUT	
u_{j01}	random uncertainty (see note in clause A.18 of TR 102 273-1-2 and note in clause 6.4.7 of TR 102 273-1-1)	

The standard uncertainties from table 11 should be given values according to annex A of TR 102 273-1-1 [4]. They should then be combined by RSS in accordance with clause 5 of TR 102 273-1-1 [4]. This gives the combined standard uncertainty (u_c contributions from the measurement) for the EUT measurement in dB.

7.2.7.1 Expanded uncertainty of the Adjacent channel power measurement

For a relative measurement (dBc) of adjacent channel power, the combined uncertainty, u_c , of the measurement is simply the value for u_c contributions from the measurement derived above.

In this case, the expanded uncertainty is $\pm 1,96 \times u_c = \pm \text{---}, \text{---}$ dB at a 95 % confidence level.

For those test Standards that require the adjacent channel power to be given in absolute terms, however, for the calculation of the measurement uncertainty, the test fixture measurement should be considered as stage two of a test in which stage one was on an accredited free field test site. The combined standard uncertainty, u_c , of the adjacent channel power measurement is therefore, simply the RSS combination of the value for u_c contributions from the measurement derived above and the combined uncertainty of the free field test site u_c contribution from the free field test site:

$$u_c = \sqrt{u_{c \text{ contributions from the measurement}}^2 + u_{c \text{ contributions from the free-field test site}}^2} = \text{---}, \text{---} \text{ dB} \quad (7.2)$$

The expanded uncertainty is $\pm 1,96 \times u_c = \pm \text{---}, \text{---}$ dB at a 95 % confidence level.

7.3 Receiver tests

The tests carried out on receivers can be divided into two categories, namely sensitivity and immunity.

Sensitivity tests determine how well a receiver can accept wanted signals in the absence of interference, whereas immunity tests, by involving two or three signal generators, determine the ability of a receiver to accept a wanted signal in the presence of different types of interference. The latter tests should, strictly speaking, contain the word "immunity" in their titles but, in the present document, historically well-established test names such as co-channel rejection and adjacent channel selectivity have been retained.

7.3.1 Maximum usable sensitivity (30 MHz to 1 000 MHz)

The receiver output detected in this test depends on the type of information the receiver has been designed to demodulate. There are principally three different types of information: analogue speech, bit stream and messages.

Definition

For analogue speech:

- the **maximum usable sensitivity** expressed as field strength is the minimum of eight field strength (in dB μ V/m) measurements (at 45° increments in the horizontal plane) at the nominal frequency of the receiver and with specified test modulation, which produces a SINAD ratio of 20 dB measured at the receiver input through a telephone psophometric weighting network. The starting horizontal angle is the reference orientation as stated by the manufacturer.

For bit stream:

- the **maximum usable sensitivity** expressed as field strength is the minimum of eight field strength (in dB μ V/m) measurements (at 45° increments in the horizontal plane) at the nominal frequency of the receiver and with specified test modulation, which produces, after demodulation, a data signal with a bit error ratio of 10^{-2} measured at the receiver input. The starting horizontal angle is the reference orientation as stated by the manufacturer.

For messages:

- the **maximum usable sensitivity** expressed as field strength is the minimum of eight field strength (in dB μ V/m) measurements (at 45° increments in the horizontal plane) at the nominal frequency of the receiver, and with specified test modulation, which produces, after demodulation, a message acceptance ratio of 80 % measured at the receiver input. The starting horizontal angle is the reference orientation as stated by the manufacturer.

NOTE: For a test fixture, no facility is usually incorporated into its structure to allow for rotation in 45° increments as called for in the definitions. Strictly speaking therefore this test should not be termed either maximum or average usable sensitivity. However, since the changes in performance caused by extreme conditions are determined for the same orientation of the EUT in the test fixture and further, that its performance in that orientation under normal conditions is related to a true maximum usable sensitivity test on an accredited test site, the results are regarded as being fully representative of a maximum usable sensitivity test.

7.3.1.1 Apparatus required

- Digital voltmeter;
- Ferrite beads;
- 10 dB attenuator;
- Power supply;
- Connecting cables;
- Test Fixture;
- Climatic facility;
- Accredited free field test site.

Additional requirements for analogue speech:

- AF source;
- SINAD Meter (incorporating telephone psophometric weighting network);
- Acoustic coupler (alternatively: audio load).

Additional requirements for bit stream:

- Bit stream generator;
- Bit error measuring test set.

Additional requirements for messages:

- Acoustic coupler;
- Message generator;
- Response measuring test set.

The type and serial numbers of all items of test equipment should be recorded on page 1 of the log book results sheet (see table 12).

7.3.1.2 Method of measurement

- 1) The test fixture should have been verified for use, with the particular type of EUT, on an accredited free field test site in accordance with clause 6. Four different measurements of the value of maximum usable sensitivity (for the particular modulation type) should have been taken during the verification, each corresponding to a different configuration of the EUT, namely:
 - a) the EUT by itself on the accredited free field test site;
 - b) the EUT secured in the test fixture, again on the accredited free field test site;
 - c) the power input to the test fixture's RF connector with the test fixture/EUT assembly on the accredited free field test site;

d) the power input to the test fixture's RF connector with the test fixture/EUT assembly in the climatic facility.

The value recorded for configuration b) during the verification procedure should be entered on page 1 of the log book results sheet (see table 12).

- 2) The EUT should still be secured in the test fixture and the test fixture/EUT assembly should be placed in the climatic facility in a repeatable position. This configuration should be noted on page 1 of the log book results sheet (see table 12).
- 3) Normal conditions (as stated in the relevant testing standard) should exist within the climatic facility.

For analogue speech:

- 4a) The EUT should be connected to the modulation detector (a SINAD meter incorporating a telephone psophometric weighting network) through an AF load or by an acoustic coupler which is made from low dielectric constant (i.e. less than 1,5) material(s) for EUTs not fitted with a direct connection (see figure 9).
- 4b) The signal generator output should be modulated with test modulation AM-1 (produced by the AF source) and its output level should be adjusted until a psophometrically weighted SINAD ratio of 20 dB is obtained from the EUT. The corresponding signal generator output power level should be recorded on page 2 of the log book results sheet (see table 12).
- 4c) The procedure should now resume with Step 5.

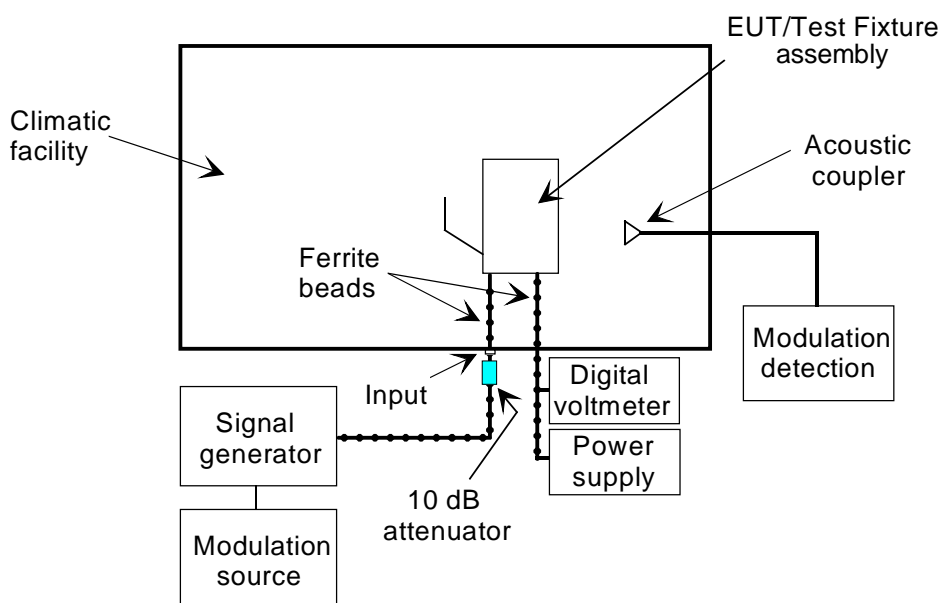

Figure 9: Maximum usable sensitivity using a test fixture (shown with acoustic coupler)

For bit stream:

- 4a) The EUT should be connected to the modulation detector (a bit error measuring test set, which should also receive a direct input from the bit stream generator) by a direct connection (see figure 9).
- 4b) The signal generator output should be modulated with test modulation DM-2 (produced by the bit stream generator) and its output level should be adjusted until a bit error ratio of 10^{-2} is obtained from the EUT. The corresponding signal generator output power level should be recorded on page 2 of the log book results sheet (see table 12).
- 4c) The procedure should now resume with Step 5.

For messages:

- 4a) The EUT should be connected to the modulation detector (a response measuring test set) via an acoustic coupler (pipe) which is made from low dielectric constant (i.e. less than 1,5) material(s) (see figure 9).

- 4b) The signal generator output should be modulated with test modulation DM-3 (produced by the message generator) and its output level should be adjusted until a message acceptance ratio of less than 10 % is obtained from the EUT.
- 4c) The test message should be transmitted repeatedly from the test antenna, whilst observing for each message whether a successful response is obtained. The output level of the signal generator should be increased by 2 dB for each occasion that a successful response is NOT obtained.
- 4d) Step 4c should be repeated until three consecutive successful responses are observed at the same output level from the signal generator. The output level from the signal generator should be recorded on page 2 of the log book results sheet (see table 12).
- 4e) The output signal level from the signal generator should be reduced by 1 dB. The new signal level should be recorded on page 2 of the log book results sheet (see table 12) and the response of the EUT observed.
- 4f) If a successful response is NOT obtained, the output signal level should be increased by 1 dB and the new level recorded in the results sheet. If a successful response IS obtained, the input level should not be changed until three consecutive successful responses have been observed. In this case, the output signal level from the signal generator should be reduced by 1 dB and the new level recorded in the results sheet. No signal levels should be recorded unless preceded by a change of level.
- 4g) Step 4f should be repeated until a total of 10 recorded values for the signal generator output level have been entered on page 2 of the log book results sheet (see table 12).
- 4h) The 10 recorded values of the signal generator output level (dBm) should be converted into linear values by the following equation:

$$\text{field strength} = \sqrt{10^{\frac{(dBm)}{10}}} \quad (7.3)$$

The resulting values should be also entered on page 2 of the log book results sheet (see table 12).

- 4i) The 10 new recorded values of field strength should then be averaged and finally converted back to dBm according to the following formula:

$$\text{Average output level} = 20 \log \left(\frac{\sum_{i=1}^{10} \sqrt{10^{\frac{(dBmi)}{10}}}}{10} \right)^2 \text{ dBm} \quad (7.4)$$

- 4j) The resulting value for average signal generator output power level should be entered on page 2 of the log book results sheet (see table 12).
- 4k) The procedure should now continue with Step 5.
- 5) The EUT and its power supplies should then be switched off and the climatic facility programmed to provide the upper extreme of temperature.
- 6) The climatic facility should be allowed adequate time at the extreme condition for all components to settle to the temperature required.

NOTE 1: For tests at extreme conditions, the relevant testing standard will specify the extreme temperatures and voltages to apply, along with stabilization and operating periods which should both be completed before any measurements are carried out.

NOTE 2: To avoid thermally shocking the EUT, it is recommended that the rates of change of temperature should not exceed 1°C per minute. The preferred rate of change of temperature is 0,33°C per minute.

- 7) The supply voltage to the EUT should be set to the upper extreme as given in the relevant testing standard. The multi-stage Step 4 should then be repeated.

- 8) The supply voltage to the EUT should then be set to the lower extreme as given in the relevant testing standard. The multi-stage Step 4 should then be repeated.
 - 9) The EUT and its power supplies should then be switched off and the climatic facility programmed to provide the lower extreme of temperature.
 - 10) The climatic facility should be allowed adequate time at the extreme temperature condition for all components to settle to the temperature required.
- NOTE 3: For tests at extreme conditions, the relevant testing standard will specify the extreme temperatures and voltages to apply, along with stabilization and operating periods which should both be completed before any measurements are carried out.
- NOTE 4: To avoid thermally shocking the EUT, it is recommended that the rates of change of temperature should not exceed 1°C per minute. The preferred rate of change of temperature is 0,33°C per minute.
- 11) The supply voltage to the EUT should then be set to the lower extreme as given in the relevant testing standard. The multi-stage Step 4 should then be repeated.
 - 12) The supply voltage to the EUT should be set to the upper extreme as given in the relevant testing standard. The multi-stage Step 4 should then be repeated.
 - 13) On completion of the extreme conditions, the climatic facility should be returned to the normal condition.

7.3.1.3 Procedure for the completion of the results sheets

The results taken during the above test method should be processed as follows. Firstly, all the recorded values for the signal generator output power levels (the average level for the case of messages) should be normalized to the value corresponding to normal conditions of temperature and voltage by simple subtraction of the dBm values. The normalized values should then be entered in the log book results sheet (see table 12) and subsequently converted into numerical factors according to the following formula:

$$\text{Normalized numerical factor} = 10^{\left(\frac{\text{normalized signal generator level in dB}}{20}\right)} \quad (7.5)$$

All five resulting values of the numerical factor should be entered in the log book results sheet (see table 12).

The value of maximum usable sensitivity ($\mu\text{V}/\text{m}$) recorded on the accredited free field test site should then be multiplied by the normalized numerical factor and the resulting values recorded in the overall results sheet (see table 13).

Finally, to complete the overall results sheet, the expanded uncertainty should be calculated in accordance with clause 7.3.2.

7.3.1.4 Log book entries

Table 12: Log book results sheet

MAXIMUM USABLE SENSITIVITY		Date:	PAGE 1 of 2	
Temperature:.....°C	Humidity:.....%	Frequency:.....MHz		
Bandwidth of Receiving Device.....Hz		Manufacturer of EUT:.....		
Type No:.....		Serial No:.....		
Test equipment item	Type No.	Serial No.	VSWR	Insertion loss
Digital voltmeter			N/A	N/A
Power supply			N/A	N/A
Ferrite beads (for RF cables)			N/A	N/A
Ferrite beads (for power cables)			N/A	N/A
10 dB attenuator				
Signal generator				N/A
Signal generator cable				
RF cable within climatic facility				
Climatic facility			N/A	N/A
Accredited free field test site			N/A	N/A
AF source (if applicable)			N/A	N/A
SINAD meter (if applicable)			N/A	N/A
Audio load (if applicable)			N/A	N/A
Bit stream generator (if applicable)			N/A	N/A
Bit error measuring test set (if applicable)			N/A	N/A
Acoustic coupler (if applicable)			N/A	N/A
Message generator (if applicable)			N/A	N/A
Response measuring test set (if applicable)			N/A	N/A
Result of measurement on accredited free field test site:				
Type of site:.....				
Maximum usable sensitivity ($\mu\text{V}/\text{m}$) b).....				
Mounting configuration of EUT				

MAXIMUM USABLE SENSITIVITY (analogue speech)			Date:	PAGE 2 of 2	
Temperature, °C	Voltage, Volts	Signal generator level, dBm, for 20 dB SINAD	Normalized signal generator level		
			dB	Numerical	
T (normal)	V (normal)		0,0	1,0	
T (high)	V (high)				
	V (low)				
T (low)	V (high)				
	V (low)				

MAXIMUM USABLE SENSITIVITY (bit stream)			Date:	PAGE 2 of 2	
Temperature, °C	Voltage, Volts	Signal generator level, dBm, for 10 ⁻² BER	Normalized signal generator level		
			dB	Numerical	
T (normal)	V (normal)		0,0	1,0	
T (high)	V (high)				
	V (low)				
T (low)	V (high)				
	V (low)				

MAXIMUM USABLE SENSITIVITY (messages)						Date:	PAGE 2 of 2	
	T(normal)	T(high)	T(low)					
	V(normal)	V(high)	V(low)	V(high)				
Signal generator output level 1								
Signal generator output level 2								
Signal generator output level 3								
Signal generator output level 4								
Signal generator output level 5								
Signal generator output level 6								
Signal generator output level 7								
Signal generator output level 8								
Signal generator output level 9								
Signal generator output level 10								
Converting to linear value								
linear value for sig gen level 1								
linear value for sig gen level 2								
linear value for sig gen level 3								
linear value for sig gen level 4								
linear value for sig gen level 5								
linear value for sig gen level 6								
linear value for sig gen level 7								
linear value for sig gen level 8								
linear value for sig gen level 9								
linear value for sig gen level 10								
Average of the 10 values								
Normalized signal generator level dB								
Normalized signal generator level								
Numerical value								

7.3.1.5 Statement of results

The results should be presented in tabular form as shown in table 13.

Table 13: Overall results sheet

MAXIMUM USABLE SENSITIVITY		Date:		PAGE 1 of 1		
	T(normal)	T(high)		T(low)		
	V(normal)	V(high)	V(low)	V(high)	V(low)	
Maximum usable sensitivity in the test fixture $\mu\text{V/m}$						
Expanded uncertainty (95 %)						dB

7.3.2 Measurement uncertainty for Maximum usable sensitivity

All the uncertainty contributions for the test are listed in table 14.

Table 14: Contributions from the measurement

$u_{j \text{ or } i}$	Description of uncertainty contributions	dB
u_{j38}	signal generator: absolute output level	
u_{j39}	signal generator: output level stability	
u_{j60}	Test Fixture: effect on the EUT	
u_{j61}	Test Fixture: climatic facility effect on the EUT	
u_{j01}	random uncertainty (see note in clause A.18 of TR 102 273-1-2 and note in clause 6.4.7 of TR 102 273-1-1)	

The standard uncertainties from table 14 should be given values according to annex A of TR 102 273-1-1 [4]. They should then be combined by RSS in accordance with TR 102 273-1-1 [4]. This gives the combined standard uncertainty (u_c contributions from the measurement) for the EUT measurement in dB.

7.3.2.1 Expanded uncertainty of the maximum usable sensitivity measurement

Tests in a test fixture differ to radiated tests on all other types of site in that there is only one stage to the test. However, to calculate the measurement uncertainty, the Test Fixture measurement should be considered as stage two of a test in which stage one was on an accredited free field test site. The combined standard uncertainty, u_c , of the maximum usable sensitivity measurement is therefore, simply the RSS combination of the value for u_c contributions from the measurement derived above and the combined uncertainty of the free field test site u_c contribution from the free field test site:

$$u_c = \sqrt{u_{c \text{ contributions from the measurement}}^2 + u_{c \text{ contributions from the free-field test site}}^2} = \text{___, ___ dB} \quad (7.6)$$

The expanded uncertainty is $\pm 1,96 \times u_c = \pm \text{___, ___ dB}$ at a 95 % confidence level.

7.3.3 Average usable sensitivity

The measurement of average usable sensitivity in a Test Fixture is not possible, since the position of the EUT within the Test Fixture is usually fixed and therefore cannot be rotated to the eight different angles which the averaging process requires.

7.3.4 Co-channel rejection

Definition

The **co-channel rejection** is a measure of the capability of the receiver to receive a wanted modulated signal at the nominal frequency without exceeding a given degradation due to the presence of an unwanted modulated signal also at the nominal frequency.

For analogue speech:

- it is specified as the ratio in decibels of the level of the unwanted signal to the specified wanted signal level at the receiver input which produces, through a telephone psophometric weighting network, a SINAD ratio of 14 dB.

For bit stream:

- it is specified as the ratio in decibels of the level of the unwanted signal to the specified wanted signal level at the receiver input for which the bit error ratio is 10^{-2} .

For messages:

- it is specified as the ratio in decibels of the level of the unwanted signal to the specified wanted signal level at the receiver input for which the message acceptance ratio is 80 %.

7.3.4.1 Apparatus required

- Digital voltmeter.
- Power supply.
- Connecting cables.
- Ferrite beads.
- 10 dB attenuator.
- Test Fixture.
- Climatic facility.
- Accredited free field test site.
- Two RF signal generators.
- 50 Ω load.
- AF source.

Additional requirements for analogue speech:

- Second AF source.
- SINAD meter (incorporating telephone psophometric weighting network).
- Acoustic coupler (alternatively: audio load).

Additional requirements for bit stream:

- Bit stream generator.
- Bit error measuring test set.

Additional requirements for messages:

- Acoustic coupler.
- Message generator.
- Response measuring test set.

The type and serial numbers of all items of test equipment should be recorded on page 1 of the log book results sheet (see table 15).

7.3.4.2 Method of measurement

- 1) The Test Fixture should have been verified for use, with the particular type of EUT, on an accredited free field test site in accordance with clause 6. Four different measurements of the value of maximum usable sensitivity (for the particular type of data modulation i.e. analogue speech, bit stream or messages) should have been taken during the verification, each corresponding to a different configuration of the EUT, namely:
 - a) the EUT by itself on the accredited free field test site;
 - b) the EUT secured in the Test Fixture, again on the accredited free field test site;
 - c) the power input to the Test Fixture's RF connector with the Test Fixture/EUT assembly on the accredited free field test site;
 - d) the power input to the Test Fixture's RF connector with the Test Fixture/EUT assembly in the climatic facility.

The value recorded for configuration b) during the verification procedure should be entered on page 2 of the log book results sheet (see table 15). This value should be converted to dB μ V/m (from μ V/m) before entering it in the log book results sheet.

For all modulation types, the maximum usable sensitivity limit (as stated in the relevant testing standard) as well as the calculated difference between this value and the b) value recorded during the verification procedure should both be entered on page 2 of the log book results sheet (see table 15).

- 2) The EUT should still be secured in the Test Fixture and the Test Fixture/EUT assembly should be placed in the climatic facility in a repeatable position. This configuration should be noted on page 1 of the log book results sheet (see table 15).
- 3) The assembly should be connected to the test equipment as shown in figure 10 where acoustic coupling to the EUT is illustrated.

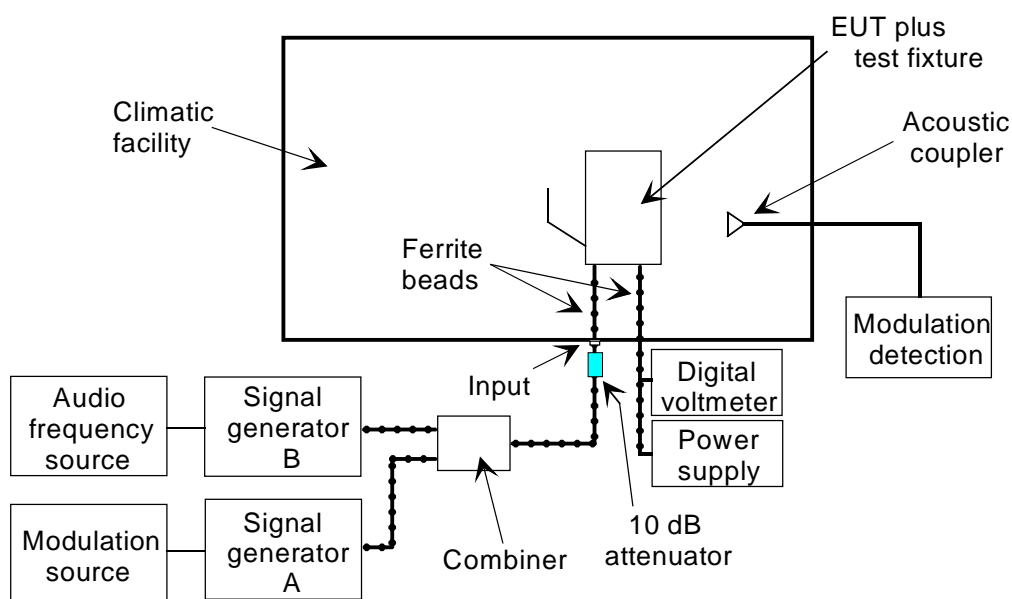

Figure 10: Co-channel rejection using a Test Fixture (shown with acoustic coupler)

- 4) Normal conditions (as stated in the relevant standard) should exist within the climatic facility.
- 5) The output from signal generator B should be tuned to the nominal frequency of the EUT. It should be modulated with test modulation A-M3 produced by the AF generator. This is the unwanted signal as far as the test is concerned.

For analogue speech:

- 6a) The output from signal generator A should be tuned to the nominal frequency of the EUT. It should be modulated by test modulation A-M1 produced by the modulation source (an AF generator). This is the wanted signal as far as the test is concerned.
- 6b) The output signal level of signal generator B should be switched off and the cable from its output should be disconnected at the combiner input. The vacated combiner port should then be terminated with a 50 Ω load.
- 6c) The output signal level of signal generator A should be adjusted until the modulation detector (a SINAD meter incorporating a telephone psophometric weighting network) indicates a 20 dB SINAD ratio has been obtained. The signal generator level should be increased by the difference between the limit of the maximum usable sensitivity - the free field test site measured maximum usable sensitivity. The corresponding output power level of signal generator A should be recorded on page 2 of the log book results sheet (see table 15).

NOTE 1: The output level increase is the difference between the limit for maximum usable sensitivity (as given in the relevant standard) and the measured value of maximum usable sensitivity for the complete EUT/Test Fixture assembly recorded on the accredited test-site.

- 6d) The cable from the output of signal generator B should then be reconnected to the combiner port (replacing the 50 Ω load).
- 6e) The output of signal generator B should then be switched on and its level adjusted until the SINAD ratio (again as measured through a telephone psophometric weighting network) is reduced to 14 dB. The corresponding output power level of signal generator B should be recorded on page 2 of the log book results sheet (see table 15).
- 6f) Retaining its modulation A-M3, signal generator B should then be tuned, in succession, to frequencies 1 500 Hz and 3 000 Hz above and below the nominal frequency. For each frequency, Step 6e should be repeated keeping the tuning and modulation of signal generator A as set in Step 6a and its output level as set in Step 6c.
- 6g) The procedure should now resume with Step 7.

For bit stream:

- 6a) The output from signal generator A should be tuned to the nominal frequency of the EUT. It should be modulated by test modulation D-M2 produced by the modulation source (a bit stream generator). This is the wanted signal as far as the test is concerned.
- 6b) The output signal level of signal generator B should be switched off and the cable from its output should be disconnected at the combiner input. The vacated combiner port should then be terminated with a 50 Ω load.
- 6c) The EUT should be directly connected to the modulation detector (a bit error measuring test set which should also receive a direct input from the bit stream generator) and the output signal level of signal generator A should be adjusted until a bit error ratio of 10^{-2} is obtained. The corresponding output power level of signal generator A should be recorded on page 2 of the log book results sheet (see table 15).
- 6d) The output signal level of signal generator A should then be increased above the level noted in Step 6c by the difference in the two values recorded in Step 1 plus 3 dB. This new value of signal generator output level should be recorded on page 2 of the log book results sheet (see table 15).

NOTE 2: The output level increase is 3 dB plus the difference between the limit for maximum usable sensitivity (as given in the relevant standard) and the measured value of maximum usable sensitivity for the complete EUT/Test Fixture assembly recorded on the accredited test-site.

- 6e) The cable from the output of signal generator B should then be reconnected to the combiner port (replacing the 50 Ω load).
- 6f) The output of signal generator B should then be switched on and its level adjusted until a bit error ratio of about 10^{-1} is obtained.
- 6g) The wanted signal should be transmitted at the level set in Step 6d whilst the level of signal generator B (the unwanted signal) is reduced in 1 dB steps until a bit error ratio of 10^{-2} or better is obtained. The corresponding output power level of signal generator B should be recorded on page 2 of the log book results sheet (see table 15).

6h) Retaining its modulation A-M3, signal generator B should then be tuned, in succession, to frequencies 1 500 Hz and 3 000 Hz above and below the nominal frequency. For each frequency, Steps 6f and 6g should be repeated keeping the tuning and modulation of signal generator A as set in Step 6a and its output level as set in Step 6d.

6i) The procedure should now resume with Step 7.

For messages:

6a) The output from signal generator A should be tuned to the nominal frequency of the EUT. It should be modulated by test modulation D-M3. This is the wanted signal as far as the test is concerned.

6b) The output signal level of signal generator B should be switched off and the cable from its output should be disconnected at the combiner input. The vacated combiner port should then be terminated with a 50 Ω load.

6c) The output signal level of signal generator A should be adjusted until the modulation detector (a response measuring test set) indicates that a successful message response ratio of less than 10 % has been obtained.

6d) The output signal level of signal generator A should then be successively increased in 2 dB steps for each occasion that a successful response **is not** obtained until 3 consecutive successful responses are observed. The corresponding output signal level should be recorded on page 2 of the log book results sheet (see table 15).

6e) The output signal level of signal generator A should then be decreased by 1 dB and the new value recorded on page 2 of the log book results sheet (see table 15). The message should then be continuously repeated. In each case, if a successful response **is not** obtained, the input level should be increased by 1 dB and the new value recorded. If a successful response **is** obtained, the input level should not be changed until three consecutive successful responses have been observed. In this case, the input level should be reduced by 1 dB and the new value recorded in the log book results sheet. No input signal levels should be recorded unless **preceded** by a change in signal level. The repetition should be stopped after 10 values of signal level have been recorded in the log book results sheet (see table 15).

6f) The 10 values of signal generator output level recorded should then be averaged and the resulting value should be entered on page 2 of the log book results sheet (see table 15).

6g) The output signal level of signal generator A should then be increased above the calculated average level recorded in Step 6f by the difference in the two values recorded in Step 1 plus 3 dB. This new value of signal generator output level should be recorded on page 2 of the log book results sheet (see table 15).

NOTE 3: The output level increase is 3 dB plus the difference between the limit for maximum usable sensitivity (as given in the relevant testing standard) and the measured value of maximum usable sensitivity for the complete EUT/Test Fixture assembly recorded on the accredited test-site.

6h) The cable from the output of signal generator B should then be reconnected to the combiner port (replacing the 50 Ω load).

6i) Whilst repeatedly transmitting the message from signal generator A, the output of signal generator B should then be switched on and its output level adjusted until a successful message acceptance ratio of less than 10 % is obtained.

6j) The output signal level of signal generator B should then be successively reduced in 2 dB steps for each occasion that a successful response **is not** obtained until 3 consecutive successful responses are observed. The corresponding output signal level from signal generator B should be recorded on page 2 of the log book results sheet (see table 15).

6k) The output signal level of signal generator B should then be increased by 1 dB and the new value recorded on page 2 of the log book results sheet (see table 15). The wanted signal (signal generator A) should then be repeatedly transmitted. In each case, if a successful response **is not** obtained, the level of the unwanted signal (signal generator B) should be reduced by 1 dB and the new value recorded. If a successful response **is** obtained, the level of the unwanted signal should not be changed until three consecutive successful responses have been observed. In this case, the unwanted signal level should be reduced by 1 dB and the new value recorded in the log book results sheet. No levels of the unwanted signal should be recorded unless **preceded** by a change in signal level. The repetition should be stopped after 10 values of signal level have been recorded in the log book results sheet (see table 15).

6l) The 10 values of signal level recorded should then be averaged and the resulting value should be entered on page 2 of the log book results sheet (see table 15).

6m) Retaining its modulation A-M3, signal generator B should then be tuned, in succession, to frequencies of 1 500 Hz and 3 000 Hz above and below the nominal frequency. For each frequency, Steps 6i to 6l should be repeated keeping the tuning and modulation of signal generator A as set in Step 6a and its output level as set in Step 6g.

6n) The procedure should now continue with Step 7.

7) The EUT and its power supplies should then be switched off and the climatic facility programmed to provide the upper extreme of temperature.

8) The climatic facility should be allowed adequate time at the extreme condition for all components to settle to the temperature required.

NOTE 4: For tests at extreme conditions, the relevant testing standard will specify the extreme temperatures and voltages to apply, along with stabilization and operating periods which should both be completed before any measurements are carried out.

NOTE 5: To avoid thermally shocking the EUT, it is recommended that the rates of change of temperature should not exceed 1°C per minute. The preferred rate of change of temperature is 0,33°C per minute.

9) The supply voltage to the EUT should be set to the upper extreme as given in the relevant testing standard. Step 5 and the multi-stage Step 6 should then be repeated.

10) The supply voltage to the EUT should then be set to the lower extreme as given in the relevant testing standard. Step 5 and the multi-stage Step 6 should again be repeated.

11) The EUT and its power supplies should then be switched off and the climatic facility programmed to provide the lower extreme of temperature.

12) The climatic facility should be allowed adequate time at the extreme temperature condition for all components to settle to the temperature required.

NOTE 6: For tests at extreme conditions, the relevant testing standard will specify the extreme temperatures and voltages to apply, along with stabilization and operating periods which should both be completed before any measurements are carried out.

NOTE 7: To avoid thermally shocking the EUT, it is recommended that the rates of change of temperature should not exceed 1°C per minute. The preferred rate of change of temperature is 0,33°C per minute.

13) The supply voltage to the EUT should be set to the lower extreme as given in the relevant testing standard. Step 5 and the multi-stage Step 6 should then be repeated.

14) The supply voltage to the EUT should then be set to the upper extreme as given in the relevant testing standard. Step 5 and the multi-stage Step 6 should again be repeated.

15) On completion of the extreme conditions, the climatic facility should be returned to the normal condition.

7.3.4.3 Procedure for completion of the results sheets

Some final calculations need to be made before the overall results sheet (see table 16) can be completed. The first of these calculations derives the difference in levels between the wanted signal and the unwanted signal for the stipulated reception (i.e. 14 dB SINAD for analogue speech, 10^{-2} bit error ratio for bit stream or 80 % message acceptance ratio for messages). In all cases, the relevant values can be found on page 2 of the log book results sheet (see table 15) and the resulting level differences are co-channel rejection ratios.

For analogue speech: For each frequency, the difference (in dB) between the signal generator A level and the level of signal generator B (for 14 dB SINAD) for each temperature/voltage combination should be calculated and entered on page 2 of the log book results sheet (see table 15). The actual calculation is:

$$\text{signal generator B level (for 14 dB SINAD) - signal generator A increased (Step 6c) level dB} \quad (7.7)$$

For bit stream: For each frequency, the difference (in dB) between the increased level (*Step 6d*) of signal generator A and the level of signal generator B (for 10^{-2} BER) for each temperature/voltage combination should be calculated and entered on page 2 of the log book results sheet (see table 15). The actual calculation is:

$$\text{signal generator B level (for } 10^{-2} \text{ BER) - signal generator A increased (Step 6d) level dB} \quad (7.8)$$

For messages: For each frequency, the difference (in dB) between the increased level (*Step 6g*) of signal generator A and the average level of signal generator B for each temperature/voltage combination should be calculated and entered on page 2 of the log book results sheet (see table 15). The actual calculation is:

$$\text{average signal generator B level - signal generator A increased (Step 6g) level dB} \quad (7.9)$$

For all types of data modulation, the co-channel rejection ratio for the EUT is the lowest of all the level differences between generators A and B. This value should be entered in the overall results sheet (see table 16).

The final value needed to complete the overall results sheet (see table 16) is the expanded measurement uncertainty. This should be calculated in accordance with clause 7.3.5.

7.3.4.4 Log book entries

Table 15: Log book results sheet

CO-CHANNEL REJECTION		Date:	PAGE 1 of 2	
Temperature:.....°C	Humidity:.....%	Frequency:.....MHz		
Manufacturer of EUT:.....	Type No:.....	Serial No:.....		
Test equipment item	Type No.	Serial No.	VSWR	Insertion loss
Digital voltmeter			N/A	N/A
Power supply			N/A	N/A
Ferrite beads (for RF cables)			N/A	N/A
Ferrite beads (for power cables)			N/A	N/A
10 dB attenuator				
Signal generator A				N/A
Signal generator B				N/A
RF cable within climatic facility				
RF cable, climatic facility output to combiner				
RF cable, combiner to sig gen A				
RF cable, combiner to sig gen B				
RF Combiner				
50 Ω load				N/A
Climatic facility			N/A	N/A
Accredited free field test site			N/A	N/A
AF source A			N/A	N/A
2nd AF source (if applicable)			N/A	N/A
SINAD meter (if applicable)			N/A	N/A
Acoustic coupler (if applicable)			N/A	N/A
Audio load (if applicable)			N/A	N/A
Bit stream generator (if applicable)			N/A	N/A
Bit error measuring test set (if applicable)			N/A	N/A
Message generator (if applicable)			N/A	N/A
Response measuring test set (if applicable)			N/A	N/A
Mounting configuration of EUT				

CO-CHANNEL REJECTION (analogue speech)			Date:				PAGE 2 of 2	
Result of measurement on accredited free field test site:								
Type of test site:.....								
"b)" value of maximum usable sensitivity (dB μ V/m):.....								
Limit of maximum usable sensitivity (as given in relevant standard)(dBμV/m).....								
Calculated difference between: Limit and measured "b)" values (dBμV/m).....								
Frequency	Temperature:	T(normal)	T(high)		T(low)			
	Voltage:	V(normal)	V (high)	V (low)	V (high)	V (low)		
f_0	Sig gen A (for 20dB SINAD):							
	Increased level of sig gen A:							
	Sig gen B (for 14dB SINAD):							
$f_0 + 1\ 500$	Sig gen B (for 14dB SINAD):							
$f_0 + 3\ 000$	Sig gen B (for 14dB SINAD):							
$f_0 - 1\ 500$	Sig gen B (for 14dB SINAD):							
$f_0 - 3\ 000$	Sig gen B (for 14dB SINAD):							
Frequency	Temperature:	T(normal)	T(high)		T(low)			
	Voltage:	V(normal)	V (high)	V (low)	V (high)	V (low)		
f_0	Sig gen A - Sig gen B :							
$f_0 + 1\ 500$	Sig gen A - Sig gen B :							
$f_0 + 3\ 000$	Sig gen A - Sig gen B :							
$f_0 - 1\ 500$	Sig gen A - Sig gen B :							
$f_0 - 3\ 000$	Sig gen A - Sig gen B :							

CO-CHANNEL REJECTION (bit stream)			Date:				PAGE 2 of 2	
Result of measurement on accredited free field test site:								
Type of test site:.....								
"b)" value of maximum usable sensitivity (dB μ V/m):.....								
Limit of maximum usable sensitivity (as given in relevant standard)(dBμV/m).....								
Calculated difference between: Limit and measured "b)" values (dBμV/m).....								
Frequency	Temperature:	T(normal)	T(high)		T(low)			
	Voltage:	V(normal)	V (high)	V (low)	V (high)	V (low)		
f_0	Sig gen A (for 10^{-2} BER):							
	Increased level of sig gen A:							
	Sig gen B (for 10^{-2} BER):							
$f_0 + 1\ 500$	Sig gen B (for 10^{-2} BER):							
$f_0 + 3\ 000$	Sig gen B (for 10^{-2} BER):							
$f_0 - 1\ 500$	Sig gen B (for 10^{-2} BER):							
$f_0 - 3\ 000$	Sig gen B (for 10^{-2} BER):							
Frequency	Temperature:	T(normal)	T(high)		T(low)			
	Voltage:	V(normal)	V (high)	V (low)	V (high)	V (low)		
f_0	Sig gen A - Sig gen B :							
$f_0 + 1\ 500$	Sig gen A - Sig gen B :							
$f_0 + 3\ 000$	Sig gen A - Sig gen B :							
$f_0 - 1\ 500$	Sig gen A - Sig gen B :							
$f_0 - 3\ 000$	Sig gen A - Sig gen B :							

CO-CHANNEL REJECTION (messages)		Date:	PAGE 2 of 2			
Result of measurement on accredited free field test site:						
Type of test site:.....						
"b)" value of maximum usable sensitivity (dBµV/m):.....						
Limit of maximum usable sensitivity (as given in relevant standard)(dBµV/m).....						
Calculated difference between: Limit and measured "b)" values (dBµV/m).....						
Frequency	Temperature:	T(normal)	T(high)		T(low)	
	Voltage:	V(normal)	V (high)	V (low)	V (high)	V (low)
f ₀	Signal generator A level 1:					
	Signal generator A level 2:					
	Signal generator A level 3:					
	Signal generator A level 4:					
	Signal generator A level 5:					
	Signal generator A level 6:					
	Signal generator A level 7:					
	Signal generator A level 8:					
	Signal generator A level 9:					
	Signal generator A level 10:					
	Average sig gen A output:					
	Increased level of sig gen A					
	Signal generator B level 1:					
	Signal generator B level 2:					
Signal generator B level 3:						
Signal generator B level 4:						
Signal generator B level 5:						
Signal generator B level 6:						
Signal generator B level 7:						
Signal generator B level 8:						
Signal generator B level 9:						
Signal generator B level 10:						
Average sig gen A output:						
f ₀ + 1 500	Signal generator B level 1:					
	Signal generator B level 2:					
	Signal generator B level 3:					
	Signal generator B level 4:					
	Signal generator B level 5:					
	Signal generator B level 6:					
	Signal generator B level 7:					
	Signal generator B level 8:					
	Signal generator B level 9:					
	Signal generator B level 10:					
Average sig gen A output:						
f ₀ + 3 000	Signal generator B level 1:					
	Signal generator B level 2:					
	Signal generator B level 3:					
	Signal generator B level 4:					
	Signal generator B level 5:					
	Signal generator B level 6:					
	Signal generator B level 7:					
	Signal generator B level 8:					
	Signal generator B level 9:					
	Signal generator B level 10:					

CO-CHANNEL REJECTION (messages)		Date:	PAGE 2 of 2			
Result of measurement on accredited free field test site:						
Type of test site:.....						
"b" value of maximum usable sensitivity (dB μ V/m):.....						
Limit of maximum usable sensitivity (as given in relevant standard)(dBμV/m).....						
Calculated difference between: Limit and measured "b" values (dBμV/m).....						
	Average sig gen A output:					
$f_0 - 1\ 500$	Signal generator B level 1:					
	Signal generator B level 2:					
	Signal generator B level 3:					
	Signal generator B level 4:					
	Signal generator B level 5:					
	Signal generator B level 6:					
	Signal generator B level 7:					
	Signal generator B level 8:					
	Signal generator B level 9:					
	Signal generator B level 10:					
	Average sig gen A output:					
$f_0 - 3\ 000$	Signal generator B level 1:					
	Signal generator B level 2:					
	Signal generator B level 3:					
	Signal generator B level 4:					
	Signal generator B level 5:					
	Signal generator B level 6:					
	Signal generator B level 7:					
	Signal generator B level 8:					
	Signal generator B level 9:					
	Signal generator B level 10:					
	Average sig gen A output:					
Frequency	Temperature:	T(normal)	T(high)		T(low)	
	Voltage:	V(normal)	V (high)	V (low)	V (high)	V (low)
f_0	Sig gen A - Sig gen B :					
$f_0 + 1\ 500$	Sig gen A - Sig gen B :					
$f_0 + 3\ 000$	Sig gen A - Sig gen B :					
$f_0 - 1\ 500$	Sig gen A - Sig gen B :					
$f_0 - 3\ 000$	Sig gen A - Sig gen B :					

7.3.4.5 Overall results sheet

The results should be presented in tabular form as shown in table 16.

Table 16: Overall results sheet

CO-CHANNEL REJECTION		Date:	PAGE 1 of 1	
Co-channel rejection ratio			dB	
Expanded uncertainty (95 %)			dB	

7.3.5 Measurement uncertainty for Co-channel rejection

All the uncertainty contributions for the test are listed in table 17.

Table 17: Contributions from the measurement

$u_{j \text{ or } i}$	Description of uncertainty contributions	dB
u_{j60}	Test Fixture: effect on the EUT	
u_{j61}	Test Fixture: climatic facility effect on the EUT	
u_{j01}	random uncertainty (see note in clause A.18 of TR 102 273-1-2 and note in clause 6.4.7 of TR 102 273-1-1)	
u_{j38}	signal generator A: absolute output level	
u_{j38}	signal generator B: absolute output level	
u_{j39}	signal generator A: output level stability	0,00
u_{j39}	signal generator B: output level stability	0,00

The standard uncertainties from table 17 should be given values according to annex A of TR 102 273-1-1 [4]. They should then be combined by RSS in accordance with clause 5 of TR 102 273-1-1 [4]. This gives the combined standard uncertainty (u_c contributions from the measurement) for the EUT measurement in dB.

7.3.5.1 Expanded uncertainty of the co-channel rejection measurement

Tests in a Test Fixture differ to radiated tests on all other types of site in that there is only one stage to the test. However, to calculate the measurement uncertainty, the Test Fixture measurement should be considered as stage two of a test in which stage one was on an accredited free field test site. The combined standard uncertainty, u_c , of the co-channel rejection measurement is therefore, simply the RSS combination of the value for u_c contributions from the measurement derived above and the combined uncertainty of the free field test site u_c contribution from the free field test site.

$$u_c = \sqrt{u_{c \text{ contributions from the measurement}}^2 + u_{c \text{ contribution from the Free-Field Test Site}}^2} = _, _ \text{ dB} \quad (7.10)$$

The expanded uncertainty is $\pm 1,96 \times u_c = \pm _, _ \text{ dB}$ at a 95 % confidence level.

7.3.6 Adjacent channel selectivity

Definition

The **adjacent channel selectivity** is a measure of the capability of the receiver to receive a wanted modulated signal at the nominal frequency without exceeding a given degradation due to the presence of an unwanted modulated signal which differs in frequency from the wanted signal by an amount equal to the adjacent channel separation for which the equipment is intended.

For analogue speech:

- it is specified as the lower value (of the upper and lower adjacent channels) of the ratios, in decibels, of the levels of the unwanted signal to a specified wanted signal level which produces, through a telephone psophometric weighting network, a SINAD ratio of 14 dB.

For bit stream:

- it is specified as the lower value (of the upper and lower adjacent channels) of the ratios, in decibels, of the levels of the unwanted signal level to a specified wanted signal level which produce a data signal with a bit error ratio of 10^{-2} .

For messages:

- it is specified as the lower value (of the upper and lower adjacent channels) of the ratios, in decibels, of the levels of the unwanted signal level to a specified wanted signal level which produces after demodulation a message acceptance ratio of 80 %.

7.3.6.1 Apparatus required

- Digital voltmeter;
- Ferrite beads;
- 10 dB attenuator;
- Power supply;
- Connecting cables;
- Test Fixture;
- Climatic facility;
- Accredited free field test site;
- Two RF signal generators;
- 50 Ω load;
- AF source.

Additional requirements for analogue speech:

- 2nd AF source;
- SINAD meter (incorporating telephone psophometric weighting network);
- Acoustic coupler (alternatively: audio load).

Additional requirements for bit stream:

- Bit stream generator;
- Bit error measuring test set.

Additional requirements for messages:

- Acoustic coupler;
- Message generator;
- Response measuring test set.

The type and serial numbers of all items of test equipment should be recorded on page 1 of the log book results sheet (see table 18).

7.3.6.2 Method of measurement

- 1) The Test Fixture should have been verified for use, with the particular type of EUT, on an accredited free field test site in accordance with clause 6. Four different measurements of the value of maximum usable sensitivity (for the particular type of data modulation i.e. analogue speech, bit stream or messages) should have been taken during the verification, each corresponding to a different configuration of the EUT, namely:
 - a) the EUT by itself on the accredited free field test site;
 - b) the EUT secured in the Test Fixture, again on the accredited free field test site;
 - c) the power input to the Test Fixture's RF connector with the Test Fixture/EUT assembly on the accredited free field test site;
 - d) the power input to the Test Fixture's RF connector with the Test Fixture/EUT assembly in the climatic facility.

The value recorded for configuration b) during the verification procedure should be entered on page 2 of the log book results sheet (see table 18). This value should be converted to dB μ V/m (from μ V/m) before entering it in the log book results sheet.

For all modulation types, the maximum usable sensitivity limit (as stated in the relevant testing standard) as well as the calculated difference between this value and the b) value recorded during the verification procedure should both be entered on page 2 of the log book results sheet (see table 18).

- 2) The EUT should still be secured in the Test Fixture and the Test Fixture/EUT assembly should be placed in the climatic facility in a repeatable position. This configuration should be noted on page 1 of the log book results sheet (see table 18).
- 3) The assembly should be connected to the test equipment as shown in figure 11 where acoustic coupling to the EUT is illustrated.

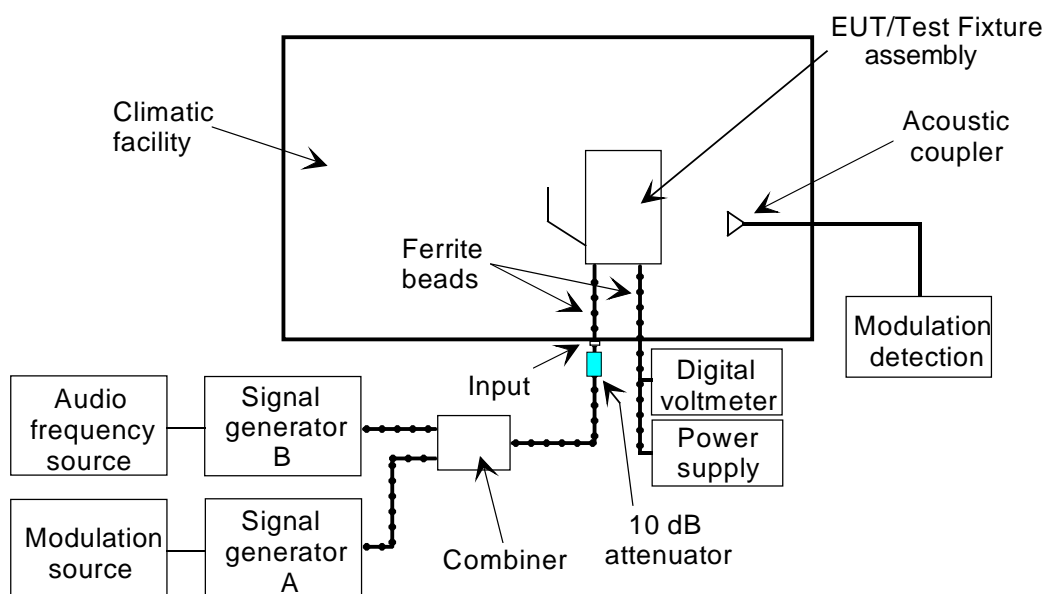

Figure 11: Adjacent channel selectivity using a Test Fixture (shown with acoustic coupler)

- 4) Normal conditions (as stated in the relevant testing standard) should exist within the climatic facility.
- 5) The output from signal generator B should be tuned to the frequency of the adjacent channel immediately above the nominal frequency of the EUT. It should be modulated with test modulation A-M3 produced by the AF generator. This is the unwanted signal as far as the test is concerned.

For analogue speech:

- 6a) The output from signal generator A should be tuned to the nominal frequency of the EUT. It should be modulated by test modulation A-M1 produced by the modulation source (an AF generator). This is the wanted signal as far as the test is concerned.
- 6b) The output signal level of signal generator B should be switched off and the cable from its output should be disconnected at the combiner input. The vacated combiner port should then be terminated with a 50 Ω load.
- 6c) The output signal level of signal generator A should be adjusted until the modulation detector (a SINAD meter incorporating a telephone psophometric weighting network) indicates a 20 dB SINAD ratio has been obtained. The signal generator level should be increased by the difference between the limit of the maximum usable sensitivity - the free field test site measured maximum usable sensitivity. The corresponding output power level of signal generator A should be recorded on page 2 of the log book results sheet (see table 18).
- 6d) 14 dB. The corresponding output power level of signal generator B should be recorded on page 2 of the log book results sheet (see table 18).
- 6e) The output from signal generator B should then be tuned to the frequency of the adjacent channel immediately below the nominal frequency. It should retain the modulation A-M3. Step 6c should be repeated keeping the tuning and modulation of signal generator A as set in Step 6a and its output level as set in Step 6c.

6f) The procedure should now resume with Step 7.

For bit stream:

- 6a) The output from signal generator A should be tuned to the nominal frequency of the EUT. It should be modulated by test modulation D-M2 produced by the modulation source (a bit stream generator). This is the wanted signal as far as the test is concerned.
- 6b) The output signal level of signal generator B should be switched off and the cable from its output should be disconnected at the combiner input. The vacated combiner port should then be terminated with a 50 Ω load.
- 6c) The EUT should be directly connected to the modulation detector (a bit error measuring test set which should also receive a direct input from the bit stream generator) and the output signal level of signal generator A should be adjusted until a bit error ratio of 10^{-2} is obtained. The corresponding output power level of signal generator A should be recorded on page 2 of the log book results sheet (see table 18).
- 6d) The output signal level of signal generator A should then be increased above the level noted in Step 6c by the difference in the two values recorded in Step 1 plus 3 dB. This new value of signal generator output level should be recorded on page 2 of the log book results sheet (see table 18).

NOTE 1: The output level increase is 3 dB plus the difference between the limit for maximum usable sensitivity (as given in the relevant testing standard) and the measured value of maximum usable sensitivity for the complete EUT/Test Fixture assembly recorded on the accredited test-site.

- 6e) The cable from the output of signal generator B should then be reconnected to the combiner port (replacing the 50 Ω load).
- 6f) The output of signal generator B should then be switched on and its level adjusted until a bit error ratio of about 10^{-1} is obtained.
- 6g) The wanted signal should be transmitted at the level set in Step 6d whilst the level of signal generator B (the unwanted signal) is reduced in 1 dB steps until a bit error ratio of 10^{-2} is obtained. The corresponding output power level of signal generator B should be recorded on page 2 of the log book results sheet (see table 18).
- 6h) The output from signal generator B should then be tuned to the frequency of the adjacent channel immediately below the nominal frequency. It should retain the modulation A-M3. Steps 6f and 6g should be repeated keeping the tuning and modulation of signal generator A as set in Step 6a and its output level as set in Step 6d.
- 6i) The procedure should now resume with Step 7.

For messages:

- 6a) The output from signal generator A should be tuned to the nominal frequency of the EUT. It should be modulated by test modulation D-M3 produced by the modulation source (a message generator). This is the wanted signal as far as the test is concerned.
- 6b) The output signal level of signal generator B should be switched off and the cable from its output should be disconnected at the combiner input. The vacated combiner port should then be terminated with a 50 Ω load.
- 6c) The output signal level of signal generator A should be adjusted until the modulation detector (a response measuring test set) indicates that a successful message response ratio of less than 10 % has been obtained.
- 6d) The output signal level of signal generator A should then be successively increased in 2 dB steps for each occasion that a successful response **is not** obtained until 3 consecutive successful responses are observed. The corresponding output signal level should be recorded on page 2 of the log book results sheet (see table 18).
- 6e) The output signal level of signal generator A should then be decreased by 1 dB and the new value recorded on page 2 of the log book results sheet (see table 18). The message should then be continuously repeated. In each case, if a successful response **is not** obtained, the input level should be increased by 1 dB and the new value recorded. If a successful response **is** obtained, the input level should not be changed until three consecutive successful responses have been observed. In this case, the input level should be reduced by 1 dB and the new value recorded in the log book results sheet. No input signal levels should be recorded unless **preceded** by a change in signal level. The repetition should be stopped after 10 values of signal level have been recorded in the log book results sheet (see table 18).

- 6f) The 10 values of signal generator output level recorded should then be averaged and the resulting value should be entered on page 2 of the log book results sheet (see table 18).
- 6g) The output signal level of signal generator A should then be increased above the calculated average level recorded in Step 6f by the difference in the two values recorded in Step 1 plus 3 dB. This new value of signal generator output level should be recorded on page 2 of the log book results sheet (see table 18).
- NOTE 2: The output level increase is 3 dB plus the difference between the limit for maximum usable sensitivity (as given in the relevant testing standard) and the measured value of maximum usable sensitivity for the complete EUT/Test Fixture assembly recorded on the accredited test-site.
- 6h) The cable from the output of signal generator B should then be reconnected to the combiner port (replacing the 50 Ω load).
- 6i) Whilst repeatedly transmitting the message from signal generator A, the output of signal generator B should then be switched on and its output level adjusted until a successful message acceptance ratio of less than 10 % is obtained.
- 6j) The output signal level of signal generator B should then be successively reduced in 2 dB steps for each occasion that a successful response **is not** obtained until three consecutive successful responses are observed. The corresponding output signal level from signal generator B should be recorded on page 2 of the log book results sheet (see table 18).
- 6k) The output signal level of signal generator B should then be increased by 1 dB and the new value recorded on page 2 of the log book results sheet (see table 18). The wanted signal (signal generator A) should then be repeatedly transmitted. In each case, if a successful response **is not** obtained, the level of the unwanted signal (signal generator B) should be reduced by 1 dB and the new value recorded. If a successful response **is** obtained, the level of the unwanted signal should not be changed until three consecutive successful responses have been observed. In this case, the unwanted signal level should be reduced by 1 dB and the new value recorded in the log book results sheet. No levels of the unwanted signal should be recorded unless **preceded** by a change in signal level. The repetition should be stopped after 10 values of signal level have been recorded in the log book results sheet (see table 18).
- 6l) The 10 values of signal level recorded should then be averaged and the resulting value should be entered on page 2 of the log book results sheet (see table 18).
- 6m) The output from signal generator B should then be tuned to the frequency of the adjacent channel immediately below the nominal frequency. It should retain the modulation A-M3. Steps 6i to 6l should be repeated keeping the tuning and modulation of signal generator A as set in Step 6a and its output level as set in Step 6g.
- 6n) The procedure should now continue with Step 7.
- 7) The EUT and its power supplies should then be switched off and the climatic facility programmed to provide the upper extreme of temperature.
- 8) The climatic facility should be allowed adequate time at the extreme condition for all components to settle to the temperature required.
- NOTE 3: For tests at extreme conditions, the relevant testing standard will specify the extreme temperatures and voltages to apply, along with stabilization and operating periods which should both be completed before any measurements are carried out.
- NOTE 4: To avoid thermally shocking the EUT, it is recommended that the rates of change of temperature should not exceed 1°C per minute. The preferred rate of change of temperature is 0,33°C per minute.
- 9) The supply voltage to the EUT should be set to the upper extreme as given in the relevant testing standard. Step 5 and the multi-stage Step 6 should then be repeated.
- 10) The supply voltage to the EUT should then be set to the lower extreme as given in the relevant testing standard. Step 5 and the multi-stage Step 6 should again be repeated.
- 11) The EUT and its power supplies should then be switched off and the climatic facility programmed to provide the lower extreme of temperature.

12) The climatic facility should be allowed adequate time at the extreme temperature condition for all components to settle to the temperature required.

NOTE 5: For tests at extreme conditions, the relevant testing standard will specify the extreme temperatures and voltages to apply, along with stabilization and operating periods which should both be completed before any measurements are carried out.

NOTE 6: To avoid thermally shocking the EUT, it is recommended that the rates of change of temperature should not exceed 1°C per minute. The preferred rate of change of temperature is 0,33°C per minute.

13) The supply voltage to the EUT should be set to the lower extreme as given in the relevant testing standard. Step 5 and the multi-stage Step 6 should then be repeated.

14) The supply voltage to the EUT should then be set to the upper extreme as given in the relevant testing standard. Step 5 and the multi-stage Step 6 should again be repeated.

15) On completion of the extreme conditions, the climatic facility should be returned to the normal condition.

7.3.6.3 Procedure for completion of the results sheets

Some final calculations need to be made before the overall results sheet (see table 19) can be completed. The first of these calculations derives the difference in levels between the wanted signal and the unwanted signal for the stipulated reception (i.e. 14 dB SINAD for analogue speech, 10^{-2} bit error ratio for bit stream or 80 % message acceptance ratio for messages). In all cases, the relevant values can be found on page 2 of the log book results sheet (see table 18) and the resulting level differences are the adjacent channel selectivity values for the EUT.

For analogue speech: For both channels, the difference (in dB) between the signal generator A level and the level of signal generator B (for 14 dB SINAD) for each temperature/voltage combination should be calculated and entered on page 2 of the log book results sheet (see table 18). The actual calculation is:

$$\text{signal generator B level (for 14 dB SINAD) - signal generator A increased (Step 6c) level dB} \quad (7.11)$$

For bit stream: For both channels, the difference (in dB) between the increased level (Step 6d) of signal generator A and the level of signal generator B (for 10^{-2} BER) for each temperature/voltage combination should be calculated and entered on page 2 of the log book results sheet (see table 18). The actual calculation is:

$$\text{signal generator B level (for } 10^{-2} \text{ BER) - signal generator A increased level (Step 6d) dB} \quad (7.12)$$

For messages: For both channels, the difference (in dB) between the increased level (Step 6g) of signal generator A and the average level of signal generator B for each temperature/voltage combination should be calculated and entered on page 2 of the log book results sheet (see table 18). The actual calculation is:

$$\text{average signal generator B level - signal generator A increased (Step 6g) level dB} \quad (7.13)$$

For all types of data modulation, the adjacent channel selectivity for the EUT is the lowest of the 10 level differences (two channels, five temperature/voltage combinations) between generators A and B. This lowest value should be entered in the overall results sheet (see table 19).

The final value needed to complete the overall results sheet (see table 19) is the expanded measurement uncertainty. This should be calculated in accordance with clause 7.3.7.

7.3.6.4 Log book entries

Table 18: Log book results sheet

ADJACENT CHANNEL SELECTIVITY		Date:	PAGE 1 of 2	
Temperature:.....°C		Humidity:.....%		Frequency:.....MHz
Manufacturer of EUT:.....		Type No:.....		Serial No:.....
Test equipment item	Type No.	Serial No.	VSWR	Insertion loss
Digital voltmeter			N/A	N/A
Power supply			N/A	N/A
Ferrite beads (for RF cables)			N/A	N/A
Ferrite beads (for power cables)			N/A	N/A
10 dB attenuator				
Signal generator A				N/A
Signal generator B				N/A
RF cable within climatic facility				
RF cable, climatic facility input to combiner				
RF cable, combiner to sig gen A				
RF cable, combiner to sig gen B				
RF Combiner				
50 Ω load				N/A
Climatic facility			N/A	N/A
Accredited free field test site			N/A	N/A
AF source			N/A	N/A
2nd AF source (if applicable)			N/A	N/A
SINAD meter (if applicable)			N/A	N/A
Acoustic coupler (if applicable)			N/A	N/A
Audio load (if applicable)			N/A	N/A
Bit stream generator (if applicable)			N/A	N/A
Bit error measuring test set (if applicable)			N/A	N/A
Message generator (if applicable)			N/A	N/A
Response measuring test set (if applicable)			N/A	N/A
Mounting configuration of EUT				

ADJACENT CHANNEL SELECTIVITY (analogue speech)			Date:	PAGE 2 of 2		
Result of measurement on accredited free field test site:						
Type of test site:.....						
"b)" value of maximum usable sensitivity (dB μ V/m):.....						
Limit of maximum usable sensitivity (as given in relevant standard)(dBμV/m).....						
Calculated difference between: Limit and measured "b)" values (dBμV/m).....						
Adjacent channel	Temperature:	T(normal)	T(high)		T(low)	
	Voltage:	V(normal)	V (high)	V (low)	V (high)	V (low)
HIGH	Sig gen A (for 20dB SINAD):					
	Increased level of sig gen A:					
	Sig gen B (for 14dB SINAD):					
LOW	Sig gen B (for 14dB SINAD):					
Adjacent channel	Temperature:	T(normal)	T(high)		T(low)	
	Voltage:	V(normal)	V (high)	V (low)	V (high)	V (low)
HIGH	Sig gen A - Sig gen B :					
LOW	Sig gen A - Sig gen B :					
Adjacent channel selectivity (dB) :						

ADJACENT CHANNEL SELECTIVITY (bit stream)			Date:	PAGE 2 of 2		
Result of measurement on accredited free field test site:						
Type of test site:.....						
"b)" value of maximum usable sensitivity (dB μ V/m):.....						
Limit of maximum usable sensitivity (as given in relevant standard)(dBμV/m).....						
Calculated difference between: Limit and measured "b)" values (dBμV/m).....						
Adjacent channel	Temperature :	T(normal)	T(high)		T(low)	
	Voltage :	V(normal)	V (high)	V (low)	V (high)	V (low)
HIGH	Sig gen A (for 10 ⁻² BER):					
	Increased level of sig gen A:					
	Sig gen B (for 10 ⁻² BER):					
LOW	Sig gen B (for 10 ⁻² BER):					
Adjacent channel	Temperature :	T(normal)	T(high)		T(low)	
	Voltage :	V(normal)	V (high)	V (low)	V (high)	V (low)
HIGH	Sig gen A - Sig gen B :					
LOW	Sig gen A - Sig gen B :					
Adjacent channel selectivity (dB) :						

ADJACENT CHANNEL SELECTIVITY (messages)		Date:		PAGE 2 of 2		
Result of measurement on accredited free field test site:						
Type of test site:.....						
"b)" value of maximum usable sensitivity (dB μ V/m):.....						
Limit of maximum usable sensitivity (as given in relevant standard)(dBμV/m).....						
Calculated difference between: Limit and measured "b)" values (dBμV/m).....						
Adjacent channel	Temperature: Voltage:	T(normal) V(normal)	T(high) V (high)	V (low)	T(low) V (high)	V (low)
HIGH	Signal generator A level 1:					
	Signal generator A level 2:					
	Signal generator A level 3:					
	Signal generator A level 4:					
	Signal generator A level 5:					
	Signal generator A level 6:					
	Signal generator A level 7:					
	Signal generator A level 8:					
	Signal generator A level 9:					
	Signal generator A level 10:					
	Average sig gen A output:					
	Increased level of sig gen A					
	Signal generator B level 1:					
	Signal generator B level 2:					
	Signal generator B level 3:					
	Signal generator B level 4:					
	Signal generator B level 5:					
	Signal generator B level 6:					
	Signal generator B level 7:					
	Signal generator B level 8:					
	Signal generator B level 9:					
	Signal generator B level 10:					
	Average sig gen A output:					
LOW	Signal generator B level 1:					
	Signal generator B level 2:					
	Signal generator B level 3:					
	Signal generator B level 4:					
	Signal generator B level 5:					
	Signal generator B level 6:					
	Signal generator B level 7:					
	Signal generator B level 8:					
	Signal generator B level 9:					
	Signal generator B level 10:					
	Average sig gen A output:					
Adjacent channel	Temperature: Voltage:	T(normal) V(normal)	T(high) V (high)	V (low)	T(low) V (high)	V (low)
HIGH	Sig gen A - Sig gen B :					
LOW	Sig gen A - Sig gen B :					
Adjacent channel selectivity (dB) :						

7.3.6.5 Overall results sheet

The results should be presented in tabular form as shown in table 19.

Table 19: Overall results sheet

ADJACENT CHANNEL SELECTIVITY		Date:	PAGE 1 of 1
Adjacent channel selectivity			dB
Expanded uncertainty (95 %)			dB

7.3.7 Measurement uncertainty for adjacent channel selectivity

All the uncertainty contributions for the test are listed in table 20.

Table 20: Contributions from the measurement

$u_{j \text{ or } i}$	Description of uncertainty contributions	dB
u_{j60}	Test Fixture: effect on the EUT	
u_{j61}	Test Fixture: climatic facility effect on the EUT	
u_{j01}	random uncertainty (see note in clause A.18 of TR 102 273-1-2 and note in clause 6.4.7 of TR 102 273-1-1)	
u_{j38}	signal generator A: absolute output level	
u_{j38}	signal generator B: absolute output level	
u_{j39}	signal generator A: output level stability	
u_{j39}	signal generator B: output level stability	

The standard uncertainties from table 20 should be given values according to annex A of TR 102 273-1-1 [4]. They should then be combined by RSS in accordance with clause 5 of TR 102 273-1-1 [4]. This gives the combined standard uncertainty (u_c contributions from the measurement) for the EUT measurement in dB.

7.3.7.1 Expanded uncertainty of the adjacent channel selectivity measurement

Tests in a Test Fixture differ to radiated tests on all other types of site in that there is only one stage to the test. However, to calculate the measurement uncertainty, the Test Fixture measurement should be considered as stage two of a test in which stage one was on an accredited free field test site. The combined standard uncertainty, u_c , of the adjacent channel selectivity measurement is therefore, simply the RSS combination of the value for u_c contributions from the measurement derived above and the combined uncertainty of the free field test site u_c contribution from the free field test site:

$$u_c = \sqrt{u_{c \text{ contributions from the measurement}}^2 + u_{c \text{ contributions from the Free-Field test site}}^2} = _, _ \text{ dB} \quad (7.14)$$

The expanded uncertainty is $\pm 1,96 \times u_c = \pm _, _ \text{ dB}$ at a 95 % confidence level.

7.3.8 Intermodulation immunity

Definition

The **intermodulation immunity** is a measure of the capability of a receiver to receive a wanted modulated signal at the nominal frequency without exceeding a given degradation due to the presence of two or more unwanted signals with a specific frequency relationship to the wanted signal frequency.

For analogue speech:

- it is specified as the ratio in decibels of the common level of two equal unwanted signals to a specified level of the wanted signal at the receiver input, which produces through a psophometric weighting network a SINAD ratio of 14 dB.

For bit stream:

- it is specified as the ratio in decibels of the common level of two equal unwanted signals to a specified level of the wanted signal at the receiver input for which the bit error ratio is 10^{-2} .

For messages:

- it is specified as the ratio in decibels of the common level of two equal unwanted signals to a specified level of the wanted signal at the receiver input for which the message acceptance ratio is 80 %.

7.3.8.1 Apparatus required

- Digital voltmeter;
- Ferrite beads;
- 10 dB attenuator;
- Power supply;
- Connecting cables;
- Test Fixture;
- Climatic facility;
- Accredited free field test site;
- 2 RF combiners;
- 3 RF signal generators;
- 50 Ω load;
- AF source.

Additional requirements for analogue speech:

- Second AF source;
- SINAD meter (incorporating telephone psophometric weighting network);
- Acoustic coupler (alternatively: audio load).

Additional requirements for bit stream:

- Bit stream generator;
- Bit error measuring test set.

Additional requirements for messages:

- Acoustic coupler;
- Message generator;
- Response measuring test set.

The type and serial numbers of all items of test equipment should be recorded in the log book results sheet (see table 21).

7.3.8.2 Method of measurement

- 1) The Test Fixture should have been verified for use, with the particular type of EUT, on an accredited free field test site in accordance with clause 6. Four different measurements of the value of maximum usable sensitivity (for the particular type of data modulation i.e. analogue speech, bit stream or messages) should have been taken during the verification, each corresponding to a different configuration of the EUT, namely:
 - a) the EUT by itself on the accredited free field test site;
 - b) the EUT secured in the Test Fixture, again on the accredited free field test site;
 - c) the power input to the Test Fixture's RF connector with the Test Fixture/EUT assembly on the accredited free field test site;
 - d) the power input to the Test Fixture's RF connector with the Test Fixture/EUT assembly in the climatic facility.

The value recorded for configuration b) during the verification procedure should be entered on page 2 of the log book results sheet (see table 21). This value should be converted to dB μ V/m (from μ V/m) before entering it in the log book results sheet.

For all modulation types, the maximum usable sensitivity limit (as stated in the relevant standard) as well as the calculated difference between this value and the b) value recorded during the verification procedure should both be entered on page 2 of the log book results sheet (see table 21).

- 2) The EUT should still be secured in the Test Fixture and the Test Fixture/EUT assembly should be placed in the climatic facility in a repeatable position. This configuration should be noted on page 1 of the log book results sheet (see table 21).
- 3) The assembly should be connected to the test equipment as shown in figure 12 where direct coupling to the audio out socket on the EUT is illustrated.

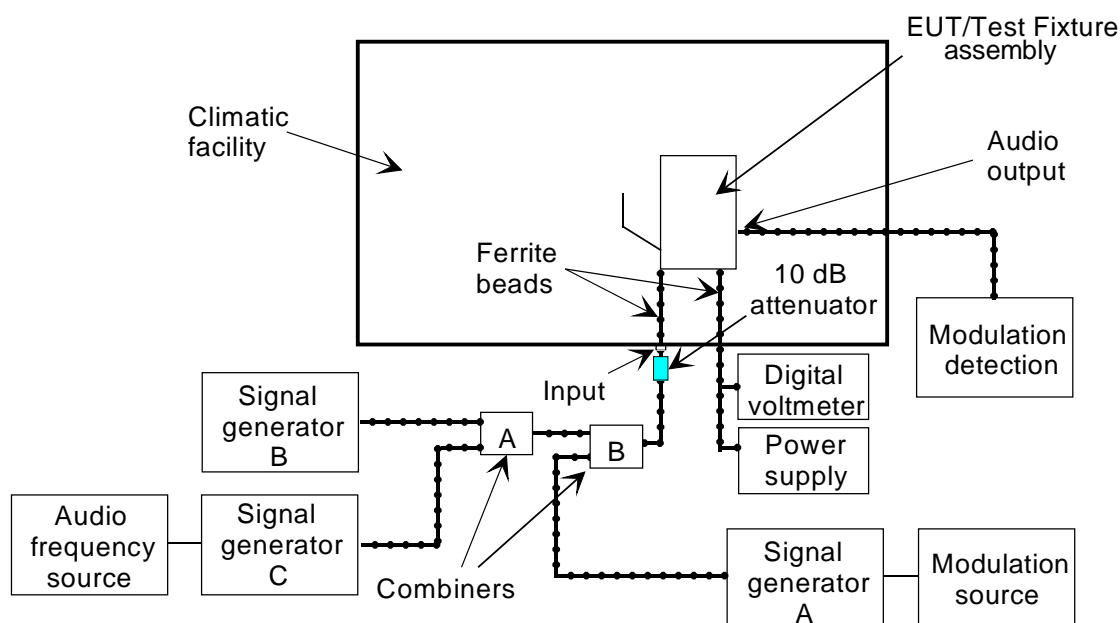

Figure 12: Intermodulation immunity using a Test Fixture (shown with a direct connection to the EUT audio out socket)

- 4) Normal conditions (as stated in the relevant testing standard) should exist within the climatic facility.
- 5) The output from signal generator B should be unmodulated and tuned to a frequency 50 kHz above the nominal frequency of the receiver. This is one of the two unwanted signals as far as the test is concerned.
- 6) The output from signal generator C should be tuned to a frequency 100 kHz above the nominal frequency of the EUT. It should be modulated with test modulation A-M3. This is the second unwanted signal as far as the test is concerned.

For analogue speech:

- 7a) The output from signal generator A should be tuned to the nominal frequency of the EUT. It should be modulated with test modulation A-M1 produced by the modulation source (an AF generator). This is the wanted signal as far as the test is concerned.
- 7b) The output signal levels of signal generators B and C should be switched off and the cable connecting the output of combiner A to one of the inputs of combiner B should be disconnected from the combiner B input port. The vacated combiner B port should then be terminated with a 50 Ω load.
- 7c) The output signal level of signal generator A should be adjusted until the modulation detector (a SINAD meter incorporating a telephone psophometric weighting network) indicates a 20 dB SINAD ratio has been obtained. The signal generator level should be increased by the difference between the limit of the maximum usable sensitivity - the free field test site measured maximum usable sensitivity. The corresponding output power level of signal generator A should be recorded on page 2 of the log book results sheet (see table 21).

NOTE 1: The output level increase is the difference between the limit for maximum usable sensitivity (as given in the relevant testing standard) and the measured value of maximum usable sensitivity for the complete EUT/Test Fixture assembly recorded on the accredited test-site.

- 7d) The cable from the output of combiner A should then be reconnected to the input of combined B (replacing the 50 Ω load).
- 7e) The two unwanted signals produced by signal generators B and C should then both be switched on. Their amplitudes, whilst being maintained equal, should be adjusted until a reduced SINAD ratio of 14 dB (again as measured through a telephone psophometric weighting network) is obtained.
- 7f) The frequency of signal generator B should then be adjusted to produce the maximum degradation to the SINAD ratio, after which the amplitudes of both unwanted signals should be re-adjusted to return to the required SINAD ratio of 14 dB. The equal levels of signal generators B and C should be recorded on page 2 of log book results sheet (see table 21).
- 7g) The outputs from signal generators B and C should then be tuned to frequencies 50 kHz and 100 kHz respectively below the nominal frequency of the receiver. The output from signal generator B should remain unmodulated, that from signal generator C should remain modulated with test modulation A-M3.
- 7h) Steps 7e and 7f should then be repeated.
- 7i) The procedure should now resume with Step 8.

For bit stream:

- 7a) The output from signal generator A should be tuned to the nominal frequency of the EUT. It should be modulated by test modulation D-M2 produced by the modulation source (a bit stream generator). This is the wanted signal as far as the test is concerned.
- 7b) The output signal levels of signal generators B and C should be switched off and the cable connecting the output of combiner A to one of the inputs of combiner B should be disconnected from the combiner B input port. The vacated combiner B port should then be terminated with a 50 Ω load.
- 7c) The EUT should be directly connected to the modulation detector (a bit error measuring test set which should also receive a direct input from the bit stream generator) and the output signal level of signal generator A should be adjusted until a bit error ratio of 10^{-2} is obtained. The corresponding output power level of signal generator A should be recorded on page 2 of the log book results sheet (see table 21).
- 7d) The output signal level of signal generator A should then be increased above the level noted in Step 7c by the difference in the two values recorded in Step 1 plus 3 dB. This new value of signal generator output level should be recorded on page 2 of the log book results sheet (see table 21).

NOTE 2: The output level increase is 3 dB plus the difference between the limit for maximum usable sensitivity (as given in the relevant testing standard) and the measured value of maximum usable sensitivity for the complete EUT/Test Fixture assembly recorded on the accredited test-site.

- 7e) The cable from the output of combiner A should then be reconnected to the input of combined B (replacing the 50 Ω load).
- 7f) The two unwanted signals produced by signal generators B and C should then both be switched on. Their amplitudes, whilst being maintained equal, should be adjusted such that a bit error ratio of about 10^{-1} is obtained.
- 7g) The wanted signal should be transmitted whilst observing the bit error ratio and the level of signal generators B and C (the unwanted signals) reduced in 1 dB steps until a bit error ratio of 10^{-2} is obtained. The corresponding output power levels of signal generators B and C should be recorded on page 2 of the log book results sheet (see table 21).
- 7h) The outputs from signal generators B and C should then be tuned to frequencies 50 kHz and 100 kHz respectively below the nominal frequency of the receiver. The output from signal generator B should remain unmodulated, that from signal generator C should remain modulated with test modulation A-M3.
- 7i) The tuning and modulation of signal generator A should be retained as set in Step 7a and its output level retained as set in Step 7d. Steps 7f and 7g should then be repeated.

For messages:

- 7a) The output from signal generator A should be tuned to the nominal frequency of the EUT. It should be modulated by test modulation D-M3 produced by the modulation source (a message generator). This is the wanted signal as far as the test is concerned.
- 7b) The output signal levels of signal generators B and C should be switched off and the cable connecting the output of combiner A to one of the inputs of combiner B should be disconnected from the combiner B input port. The vacated combiner B port should then be terminated with a 50 Ω load.
- 7c) The output signal level of signal generator A should be adjusted until a successful message response ratio of less than 10 % is obtained.
- 7d) The output signal level of signal generator A should then be successively increased in 2 dB steps for each occasion that a successful response **is not** obtained until 3 consecutive successful responses are observed. The corresponding output signal level should be recorded on page 2 of the log book results sheet (see table 21).
- 7e) The output signal level of signal generator A should then be decreased by 1 dB and the new value recorded on page 2 of the log book results sheet (see table 21). The message should then be continuously repeated. In each case, if a successful response **is not** obtained, the input level should be increased by 1 dB and the new value recorded. If a successful response **is** obtained, the input level should not be changed until three consecutive successful responses have been observed. In this case, the input level should be reduced by 1 dB and the new value recorded in the log book results sheet. No input signal levels should be recorded unless **preceded** by a change in signal level. The repetition should be stopped after 10 values of signal level have been recorded on page 2 of the log book results sheet (see table 21).
- 7f) The 10 values of signal level recorded should then be averaged and entered on page 2 of the log book results sheet (see table 21).
- 7g) The output signal level of signal generator A should then be increased above the calculated average level recorded in Step 7f by the difference in the two values recorded in Step 1 plus 3 dB. This new value of signal generator output level should be recorded on page 2 of the log book results sheet (see table 21).
- NOTE 3: The output level increase is 3 dB plus the difference between the limit for maximum usable sensitivity (as given in the relevant testing standard) and the measured value of maximum usable sensitivity for the complete EUT/Test Fixture assembly recorded on the accredited test-site.
- 7h) The cable from the output of combiner A should then be reconnected to the input port of combiner B (replacing the 50 Ω load).
- 7i) The two unwanted signals produced by signal generators B and C should then both be switched on. Their amplitudes, whilst being maintained equal, should be adjusted such that a message acceptance ratio of less than 10 % is obtained.
- 7j) The equal output signal levels of signal generators B and C should then be successively reduced in 2 dB steps for each occasion that a successful response **is not** obtained until three consecutive successful responses are observed. The corresponding output signal levels from signal generators B and C should be recorded on page 2 of the log book results sheet (see table 21).
- 7k) The equal output signal levels of signal generators B and C should then be increased by 1 dB and the new values recorded on page 2 of the log book results sheet (see table 21). The wanted signal (signal generator A) should then be continuously repeated. In each case, if a successful response **is not** obtained, the level of the unwanted signals (signal generators B and C) should be reduced by 1 dB and the new values recorded. If a successful response **is** obtained, the levels of the unwanted signals should not be changed until three consecutive successful responses have been observed. In this case, the unwanted signal levels should be reduced by 1 dB and the new values recorded in the log book results sheet. No levels of the unwanted signals should be recorded unless **preceded** by a change in signal level. The repetition should be stopped after 10 values of signal levels have been recorded on page 2 of the log book results sheet (see table 21).
- 7l) The 10 values of signal level from signal generators B and C recorded in Steps 7j and 7k should then be averaged and entered in the log book results sheet (see table 21).
- 7m) The outputs from signal generators B and C should then be tuned to frequencies 50 kHz and 100 kHz respectively below the nominal frequency of the receiver. The output from signal generator B should remain unmodulated, that from signal generator C should remain modulated with test modulation A-M3.

7n) The tuning and modulation of signal generator A should be retained as set in Step 7a and its output level retained as set in Step 7g. Steps 7i to 7l should then be repeated.

7o) The procedure should now continue with Step 8.

8) The EUT and its power supplies should then be switched off and the climatic facility programmed to provide the upper extreme of temperature.

9) The climatic facility should be allowed adequate time at the extreme condition for all components to settle to the temperature required.

NOTE 4: For tests at extreme conditions, the relevant testing standard will specify the extreme temperatures and voltages to apply, along with stabilization and operating periods which should both be completed before any measurements are carried out.

NOTE 5: To avoid thermally shocking the EUT, it is recommended that the rates of change of temperature should not exceed 1°C per minute. The preferred rate of change of temperature is 0,33°C per minute.

10) The supply voltage to the EUT should be set to the upper extreme as given in the relevant testing standard. Steps 5, 6 and the multi-stage Step 7 should then be repeated.

11) The supply voltage to the EUT should then be set to the lower extreme as given in the relevant testing standard. Steps 5, 6 and the multi-stage Step 7 should again be repeated.

12) The EUT and its power supplies should then be switched off and the climatic facility programmed to provide the lower extreme of temperature.

13) The climatic facility should be allowed adequate time at the extreme temperature condition for all components to settle to the temperature required.

NOTE 6: For tests at extreme conditions, the relevant testing standard will specify the extreme temperatures and voltages to apply, along with stabilization and operating periods which should both be completed before any measurements are carried out.

NOTE 7: To avoid thermally shocking the EUT, it is recommended that the rates of change of temperature should not exceed 1°C per minute. The preferred rate of change of temperature is 0,33°C per minute.

14) The supply voltage to the EUT should be set to the lower extreme as given in the relevant testing standard. Steps 5, 6 and the multi-stage Step 7 should then be repeated.

15) The supply voltage to the EUT should then be set to the upper extreme as given in the relevant testing standard. Steps 5, 6 and the multi-stage Step 7 should again be repeated.

16) On completion of the extreme conditions, the climatic facility should be returned to the normal condition.

7.3.8.3 Procedure for completion of the results sheets

Some final calculations need to be made before the overall results sheet (see table 22) can be completed. The first of these calculations derives the difference in levels between the wanted signal and the equal amplitude unwanted signals for the stipulated reception (i.e. 14 dB SINAD for analogue speech, 10^{-2} bit error ratio for bit stream or 80 % message acceptance ratio for messages). In all cases, the relevant values can be found on page 2 of the log book results sheet (see table 21) and the resulting level differences are the intermodulation immunity values for the EUT.

For analogue speech:

- for both frequency combinations of signal generators B and C, the difference (in dB) between the signal generator A level (for 20 dB SINAD) and the equal level of signal generators B and C (for 14 dB SINAD) for each temperature/voltage combination should be calculated and entered on page 2 of the log book results sheet (see table 22). The actual calculation is:

equal level of generators B and C (for 14 dB SINAD) - generator A increased (Step 7c) level dB (7.15)

For bit stream:

- for both frequency combinations of signal generators B and C, the difference (in dB) between the increased level (Step 7d) of signal generator A and the equal level of signal generators B and C (for 10^{-2} BER) for each temperature/voltage combination should be calculated and entered on page 2 of the log book results sheet (see table 22). The actual calculation is:

$$\text{equal level of generators B and C (for } 10^{-2} \text{ BER) - generator A increased level (Step 7d) dB} \quad (7.16)$$

For messages:

- for both frequency combinations of signal generators B and C, the difference (in dB) between the increased level (Step 7g) of signal generator A and the equal average level of signal generators B and C for each temperature/voltage combination should be calculated and entered on page 2 of the log book results sheet (see table 22). The actual calculation is:

$$\text{equal average level of generators B and C - generator A increased level (Step 7g) dB} \quad (7.17)$$

For all types of data modulation, the intermodulation immunity for the EUT is the lowest of the 10 level differences (two different frequency combinations, five temperature/voltage combinations) between generator A and jointly generators B and C. The lowest value should be entered in the overall results sheet (see table 22).

The final value needed to complete the overall results sheet (see table 22) is the expanded measurement uncertainty. This should be calculated in accordance with clause 7.3.9.

7.3.8.4 Log book entries

Table 21: Log book results sheet

INTERMODULATION IMMUNITY		Date:	PAGE 1 of 2	
Temperature:.....°C	Humidity:.....%	Frequency:.....MHz		
Manufacturer of EUT:.....	Type No:.....	Serial No:.....		
Test equipment item	Type No.	Serial No.	VSWR	Insertion loss
Digital voltmeter			N/A	N/A
Power supply			N/A	N/A
Ferrite beads (for RF cables)			N/A	N/A
Ferrite beads (for power cables)			N/A	N/A
10 dB attenuator				
Signal generator A				N/A
Signal generator B				N/A
Signal generator C				
RF cable within climatic facility				
RF cable, climatic facility input to combiner B				
RF cable, combiner B to sig gen A				
RF cable, combiner A to B				
RF cable, combiner A to sig gen B				
RF cable, combiner A to sig gen C				
RF Combiner A				
RF Combiner B				
50 Ω load				N/A
Climatic facility			N/A	N/A
Accredited free field test site			N/A	N/A
AF source			N/A	N/A
2nd AF source (if applicable)			N/A	N/A
SINAD meter (if applicable)			N/A	N/A
Acoustic coupler (if applicable)			N/A	N/A
Audio load (if applicable)			N/A	N/A
Bit stream generator (if applicable)			N/A	N/A
Bit error measuring test set (if applicable)			N/A	N/A
Message generator (if applicable)			N/A	N/A
Response measuring test set (if applicable)			N/A	N/A
Mounting configuration of EUT				

INTERMODULATION IMMUNITY (analogue speech)		Date:		PAGE 2 of 2		
Result of measurement on accredited free field test site:						
Type of test site:.....						
"b)" value of maximum usable sensitivity (i.e. IN Test Fixture) (dB μ V/m):.....						
Limit of maximum usable sensitivity (as given in relevant standard)(dBμV/m).....						
Calculated difference between: Limit and measured "b)" values (dBμV/m).....						
Frequency of B and C	Temperature: Voltage :	T(normal)	T(high)		T(low)	
		V(normal)	V (high)	V (low)	V (high)	V (low)
+50, +100 kHz	Sig gen A (for 20dB SINAD):					
	Increased level of sig gen A:					
	Sig gen B (for 14dB SINAD):					
-50, -100 kHz	Sig gen B (for 14dB SINAD):					
Frequency of B and C	Temperature: Voltage :	T(normal)	T(high)		T(low)	
		V(normal)	V (high)	V (low)	V (high)	V (low)
+50, +100 kHz	Sig gens B and C level - - Sig gen A level :					
-50, -100 kHz	Sig gens B and C level - - Sig gen A level :					

INTERMODULATION IMMUNITY (bit stream)		Date:		PAGE 2 of 2		
Result of measurement on accredited free field test site:						
Type of test site:.....						
"b)" value of maximum usable sensitivity (i.e. IN Test Fixture) (dB μ V/m):.....						
Limit of maximum usable sensitivity (as given in relevant standard)(dBμV/m).....						
Calculated difference between: Limit and measured "b)" values (dBμV/m).....						
Frequency of B and C	Temperature: Voltage :	T(normal)	T(high)		T(low)	
		V(normal)	V (high)	V (low)	V (high)	V (low)
+50, +100 kHz	Sig gen A (for 10 ⁻² BER):					
	Increased level of sig gen A:					
	Sig gens B/C (for $\geq 10^{-2}$ BER)					
-50, -100 kHz	Sig gens B/C (for $\geq 10^{-2}$ BER)					
Frequency of B and C	Temperature: Voltage :	T(normal)	T(high)		T(low)	
		V(normal)	V (high)	V (low)	V (high)	V (low)
+50, +100 kHz	Sig gens B and C level - - Sig gen A level :					
-50, -100 kHz	Sig gens B and C level - - Sig gen A level :					

INTERMODULATION IMMUNITY (messages)		Date:		PAGE 2 of 2		
Result of measurement on accredited free field test site:						
Type of test site:.....						
"b" value of maximum usable sensitivity (dB μ V/m):.....						
Limit of maximum usable sensitivity (as given in relevant standard)(dBμV/m).....						
Calculated difference between: Limit and measured "b" values (dBμV/m).....						
Frequency of B and C	Temperature: Voltage:	T(normal) V(normal)	T(high) V (high)	V (low)	T(low) V (high)	V (low)
+50, +100 kHz	Signal generator A level 1:					
	Signal generator A level 2:					
	Signal generator A level 3:					
	Signal generator A level 4:					
	Signal generator A level 5:					
	Signal generator A level 6:					
	Signal generator A level 7:					
	Signal generator A level 8:					
	Signal generator A level 9:					
	Signal generator A level 10:					
	Average sig gen A output:					
	Increased level of sig gen A					
	Sig gens B and C level 1:					
	Sig gens B and C level 2:					
	Sig gens B and C level 3:					
	Sig gens B and C level 4:					
	Sig gens B and C level 5:					
	Sig gens B and C level 6:					
	Sig gens B and C level 7:					
	Sig gens B and C level 8:					
	Sig gens B and C level 9:					
	Sig gens B and C level 10:					
	Average sig gen A output:					
-50, -100 kHz	Sig gens B and C level 1:					
	Sig gens B and C level 2:					
	Sig gens B and C level 3:					
	Sig gens B and C level 4:					
	Sig gens B and C level 5:					
	Sig gens B and C level 6:					
	Sig gens B and C level 7:					
	Sig gens B and C level 8:					
	Sig gens B and C level 9:					
	Sig gens B and C level 10:					
	Average sig gen A output:					
Frequency of B and C	Temperature: Voltage:	T(normal) V(normal)	T(high) V (high)	V (low)	T(low) V (high)	V (low)
+50, +100 kHz	Sig gens B and C level - - Sig gen A level :					
-50, -100 kHz	Sig gens B and C level - - Sig gen A level :					

7.3.8.5 Overall results sheet

The results should be presented in tabular form as shown in table 22.

Table 22: Overall results sheet

INTERMODULATION IMMUNITY		Date:	PAGE 1 of 1
Intermodulation immunity			dB
Expanded uncertainty (95 %)			dB

7.3.9 Measurement uncertainty for Intermodulation immunity

All the uncertainty contributions for the test are listed in table 23.

Table 23: Contributions from the measurement

$u_{j \text{ or } i}$	Description of uncertainty contributions	dB
u_{j60}	Test Fixture: effect on the EUT	
u_{j61}	Test Fixture: climatic facility effect on the EUT	
u_{j01}	random uncertainty (see note in clause A.18 of TR 102 273-1-2 and note in clause 6.4.7 of TR 102 273-1-1)	
u_{j38}	signal generator A: absolute output level	
u_{j39}	signal generator A: output level stability	0,00
u_{j38}	signal generator B: absolute output level	
u_{j39}	signal generator B: output level stability	0,00
u_{j38}	signal generator C: absolute output level	
u_{j39}	signal generator C: output level stability	0,00

The standard uncertainties from table 23 should be given values. They should then be combined by RSS in accordance with clause 5 of TR 102 273-1-1 [4]. This gives the combined standard uncertainty (u_c contributions from the measurement) for the EUT measurement in dB.

7.3.9.1 Expanded uncertainty of the Intermodulation immunity measurement

Tests in a Test Fixture differ to radiated tests on all other types of site in that there is only one stage to the test. However, to calculate the measurement uncertainty, the Test Fixture measurement should be considered as stage two of a test in which stage one was on an accredited free field test site. The combined standard uncertainty, u_c , of the intermodulation immunity measurement is therefore, simply the RSS combination of the value for u_c contributions from the measurement derived above and the combined uncertainty of the free field test site u_c contribution from the free field test site:

$$u_c = \sqrt{u_{c \text{ contributions from the measurement}}^2 + u_{c \text{ contribution from the Free-Field test site}}^2} = _, _ \text{ dB} \quad (7.18)$$

The expanded uncertainty is $\pm 1,96 \times u_c = \pm _, _ \text{ dB}$ at a 95 % confidence level.

7.3.10 Blocking immunity (or desensitization)

Definition

The **blocking immunity (or desensitization)** is a measure of the capability of the receiver to receive a wanted modulated signal at the nominal frequency without exceeding a given degradation due to the presence of an unwanted unmodulated high level input signal.

For analogue speech:

- it is specified as the ratio, in decibels, of the level of the unwanted signal expressed as a field strength to the specified level of the wanted signal which produces, through a telephone psophometric weighting network, a SINAD ratio of 14 dB.

For bit stream:

- it is specified as the ratio, in decibels, of the level of the unwanted signal expressed as a field strength to the specified level of the wanted signal which produces a data signal with a bit error ratio of 10^{-2} .

For messages:

- it is specified as the ratio, in decibels, of the level of the unwanted signal expressed as a field strength to the specified level of the wanted signal which produces after demodulation a message acceptance ratio of 80 %.

7.3.10.1 Apparatus required

- Digital voltmeter;
- Ferrite beads;
- 10 dB attenuator;
- Power supply;
- Connecting cables;
- Test Fixture;
- Climatic facility;
- Accredited free field test site;
- Two RF signal generators;
- 50 Ω load.

Additional requirements for analogue speech:

- AF source;
- SINAD meter (incorporating telephone psophometric weighting network);
- Acoustic coupler (alternatively: audio load).

Additional requirements for bit stream:

- Bit stream generator;
- Bit error measuring test set.

Additional requirements for messages:

- Acoustic coupler;
- Message generator;
- Response measuring test set.

The type and serial numbers of all items of test equipment should be recorded on page 1 of the log book results sheet (see table 24).

7.3.10.2 Method of measurement

- 1) The Test Fixture should have been verified for use, with the particular type of EUT, on an accredited free field test site in accordance with clause 6. Four different measurements of the value of maximum usable sensitivity (for the particular type of data modulation i.e. analogue speech, bit stream or messages) should have been taken during the verification, each corresponding to a different configuration of the EUT, namely:
 - a) the EUT by itself on the accredited free field test site;
 - b) the EUT secured in the Test Fixture, again on the accredited free field test site;
 - c) the power input to the Test Fixture's RF connector with the Test Fixture/EUT assembly on the accredited free field test site;
 - d) the power input to the Test Fixture's RF connector with the Test Fixture/EUT assembly in the climatic facility.

The value recorded for configuration b) during the verification procedure should be entered on page 2 of the log book results sheet (see table 18). This value should be converted to dB μ V/m (from μ V/m) before entering it in the log book results sheet.

For all modulation types, the maximum usable sensitivity limit (as stated in the relevant testing standard) as well as the calculated difference between it and the b) value recorded during the verification procedure should both be entered on page 2 of the log book results sheet (see table 24).

- 2) The EUT should still be secured in the Test Fixture and the Test Fixture/EUT assembly should be placed in the climatic facility in a repeatable position. This configuration should be noted on page 1 of the log book results sheet (see table 24).
- 3) The assembly should be connected to the test equipment as shown in figure 13 where acoustic coupling to the EUT is illustrated.

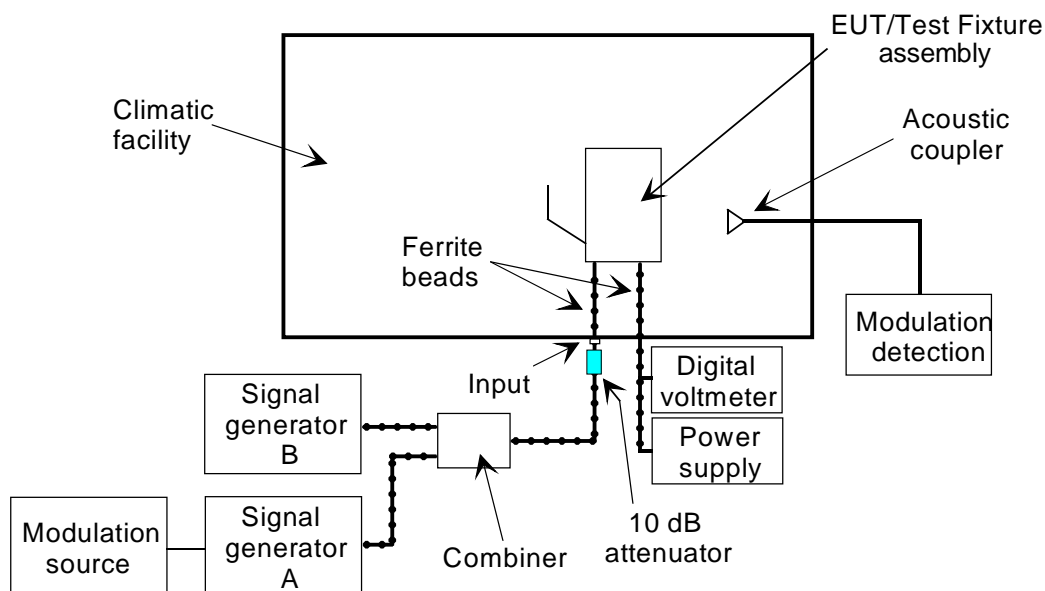

Figure 13: Blocking immunity (or desensitization) using a Test Fixture (shown with acoustic coupler)

- 4) Normal conditions (as stated in the relevant testing standard) should exist within the climatic facility.
- 5) The output from signal generator B should be tuned to a frequency 1 MHz above the nominal frequency of the EUT. It should not be modulated. This is the unwanted signal as far as the test is concerned.

For analogue speech:

- 6a) The output from signal generator A should be tuned to the nominal frequency of the EUT. It should be modulated by test modulation A-M1 produced by the modulation source (an AF generator). This is the wanted signal as far as the test is concerned.
- 6b) The output signal level of signal generator B should be switched off and the cable from its output should be disconnected at the combiner input. The vacated combiner port should then be terminated with a 50 Ω load.
- 6c) The output signal level of signal generator A should be adjusted until the modulation detector (a SINAD ratio incorporating a telephone psophometric weighting network) indicates a 20 dB SINAD ratio has been obtained. The corresponding output power level of signal generator A should be recorded on page 2 of the log book results sheet (see table 24) and the audio output power should be noted.

NOTE 1: The output level increase is the difference between the limit for maximum usable sensitivity (as given in the relevant testing standard) and the measured value of maximum usable sensitivity for the complete EUT/Test Fixture assembly recorded on the accredited test-site.

- 6d) The cable from the output of signal generator B should then be reconnected to the combiner port (replacing the 50 Ω load).
- 6e) The output of signal generator B should then be switched on and its level adjusted until the SINAD ratio (again as measured through a telephone psophometric weighting network) is reduced to 14 dB. The corresponding output power level of signal generator B should be recorded on page 2 of the log book results sheet (see table 24).

- 6f) The audio output power should be measured to ensure that it has not reduced by 3 dB or more from that noted in step 6c.
- 6g) The output from signal generator B should then be tuned, in turn, to frequencies of 2,5 and 10 MHz above the nominal frequency of the receiver, followed by 1 MHz, 2 MHz, 5 MHz and 10 MHz below the same nominal frequency. Step 6e should be repeated for each frequency, keeping the tuning and modulation of signal generator A as set in Step 6a and its output level as set in Step 6c.
- 6h) The procedure should now resume with Step 7.

For bit stream:

- 6a) The output from signal generator A should be tuned to the nominal frequency of the EUT. It should be modulated by test modulation D-M2 produced by the modulation source (a bit stream generator). This is the wanted signal as far as the test is concerned.
- 6b) The output signal level of signal generator B should be switched off and the cable from its output should be disconnected at the combiner input. The vacated combiner port should then be terminated with a 50 Ω load.
- 6c) The EUT should be directly connected to the modulation detector (a bit error measuring test set which should also receive a direct input from the bit stream generator) and the output signal level of signal generator A should be adjusted until a bit error ratio of 10^{-2} is obtained. The corresponding output power level of signal generator A should be recorded on page 2 of the log book results sheet (see table 24).
- 6d) The output signal level of signal generator A should then be increased above the level noted in Step 6c by the difference in the two values recorded in Step 1 plus 3dB. This new value of signal generator output level should be recorded on page 2 of the log book results sheet (see table 24).

NOTE 2: The output level increase is 3 dB plus the difference between the limit for maximum usable sensitivity (as given in the relevant testing standard) and the measured value of maximum usable sensitivity for the complete EUT/Test Fixture assembly recorded on the accredited test-site.

- 6e) The cable from the output of signal generator B should then be reconnected to the combiner port (replacing the 50 Ω load).
- 6f) The output of signal generator B should then be switched on and its level adjusted until a bit error ratio of about 10^{-1} is obtained.
- 6g) The wanted signal should be transmitted at the level set in Step 6d whilst the level of signal generator B (the unwanted signal) is reduced in 1 dB steps until a bit error ratio of 10^{-2} or better is obtained. The corresponding output power level of signal generator B should be recorded on page 2 of the log book results sheet (see table 24).
- 6h) The output from signal generator B should then be tuned, in turn, to frequencies of 2,5 MHz and 10 MHz above the nominal frequency of the receiver, followed by 1 MHz, 2 MHz, 5 MHz and 10 MHz below the same nominal frequency. Steps 6f and 6g should be repeated for each frequency, keeping the tuning and modulation of signal generator A as set in Step 6a and its output level as set in Step 6d.
- 6i) The procedure should now resume with Step 7.

For messages:

- 6a) The output from signal generator A should be tuned to the nominal frequency of the EUT. It should be modulated by test modulation D-M3 produced by the modulation source (a message generator). This is the wanted signal as far as the test is concerned.
- 6b) The output signal level of signal generator B should be switched off and the cable from its output should be disconnected at the combiner input. The vacated combiner port should then be terminated with a 50 Ω load.
- 6c) The output signal level of signal generator A should be adjusted until the modulation detector (a response measuring test set) indicates that a successful message response ratio of less than 10 % has been obtained.
- 6d) The output signal level of signal generator A should then be successively increased in 2 dB steps for each occasion that a successful response **is not** obtained until three consecutive successful responses are observed. The corresponding output signal level should be recorded on page 2 of the log book results sheet (see table 24).

- 6e) The output signal level of signal generator A should then be decreased by 1 dB and the new value recorded on page 2 of the log book results sheet (see table 24). The message should then be continuously repeated. In each case, if a successful response is not obtained, the input level should be increased by 1 dB and the new value recorded. If a successful response is obtained, the input level should not be changed until three consecutive successful responses have been observed. In this case, the input level should be reduced by 1 dB and the new value recorded in the log book results sheet. No input signal levels should be recorded unless preceded by a change in signal level. The repetition should be stopped after 10 values of signal level have been recorded in the log book results sheet (see table 24).
- 6f) The 10 values of signal generator output level recorded should then be averaged and the resulting value should be entered on page 2 of the log book results sheet (see table 24).
- 6g) The output signal level of signal generator A should then be increased above the calculated average level recorded in Step 6f by the difference in the two values recorded in Step 1 plus 3 dB. This new value of signal generator output level should be recorded on page 2 of the log book results sheet (see table 24).

NOTE 3: The output level increase is 3 dB plus the difference between the limit for maximum usable sensitivity (as given in the relevant testing standard) and the measured value of maximum usable sensitivity for the complete EUT/Test Fixture assembly recorded on the accredited test-site.

- 6h) The cable from the output of signal generator B should then be reconnected to the combiner port (replacing the 50 Ω load).
- 6i) Whilst repeatedly transmitting the message from signal generator A, the output of signal generator B should then be switched on and its output level adjusted until a successful message acceptance ratio of less than 10 % is obtained.
- 6j) The output signal level of signal generator B should then be successively reduced in 2 dB steps for each occasion that a successful response **is not** obtained until three consecutive successful responses are observed. The corresponding output signal level from signal generator B should be recorded on page 2 of the log book results sheet (see table 24).
- 6k) The output signal level of signal generator B should then be increased by 1 dB and the new value recorded on page 2 of the log book results sheet (see table 24). The wanted signal (signal generator A) should then be repeatedly transmitted. In each case, if a successful response **is not** obtained, the level of the unwanted signal (signal generator B) should be reduced by 1 dB and the new value recorded. If a successful response **is** obtained, the level of the unwanted signal should not be changed until three consecutive successful responses have been observed. In this case, the unwanted signal level should be reduced by 1 dB and the new value recorded in the log book results sheet. No levels of the unwanted signal should be recorded unless **preceded** by a change in signal level. The repetition should be stopped after 10 values of signal level have been recorded in the log book results sheet (see table 24).
- 6l) The 10 values of signal level recorded should then be averaged and the resulting value should be entered on page 2 of the log book results sheet (see table 24).
- 6m) The output from signal generator B should then be tuned, in turn, to frequencies of 2,5 MHz and 10 MHz above the nominal frequency of the receiver, followed by 1 MHz, 2 MHz, 5 MHz and 10 MHz below the same nominal frequency. Steps 6i and 6l should be repeated for each frequency, keeping the tuning and modulation of signal generator A as set in Step 6a and its output level as set in Step 6g.

6n) The procedure should now continue with Step 7.

- 7) The EUT and its power supplies should then be switched off and the climatic facility programmed to provide the upper extreme of temperature.
- 8) The climatic facility should be allowed adequate time at the extreme condition for all components to settle to the temperature required.

NOTE 4: For tests at extreme conditions, the relevant testing standard will specify the extreme temperatures and voltages to apply, along with stabilization and operating periods which should both be completed before any measurements are carried out.

NOTE 5: To avoid thermally shocking the EUT, it is recommended that the rates of change of temperature should not exceed 1°C per minute. The preferred rate of change of temperature is 0,33°C per minute.

- 9) The supply voltage to the EUT should be set to the upper extreme as given in the relevant testing standard. Step 5 and the multi-stage Step 6 should then be repeated.
- 10) The supply voltage to the EUT should then be set to the lower extreme as given in the relevant testing standard. Step 5 and the multi-stage Step 6 should again be repeated.
- 11) The EUT and its power supplies should then be switched off and the climatic facility programmed to provide the lower extreme of temperature.
- 12) The climatic facility should be allowed adequate time at the extreme temperature condition for all components to settle to the temperature required.
- NOTE 6: For tests at extreme conditions, the relevant testing standard will specify the extreme temperatures and voltages to apply, along with stabilization and operating periods which should both be completed before any measurements are carried out.
- NOTE 7: To avoid thermally shocking the EUT, it is recommended that the rates of change of temperature should not exceed 1°C per minute. The preferred rate of change of temperature is 0,33°C per minute.
- 13) The supply voltage to the EUT should be set to the lower extreme as given in the relevant testing standard. Step 5 and the multi-stage Step 6 should then be repeated.
- 14) The supply voltage to the EUT should then be set to the upper extreme as given in the relevant testing standard. Step 5 and the multi-stage Step 6 should again be repeated.
- 15) On completion of the extreme conditions, the climatic facility should be returned to the normal condition.

7.3.10.3 Procedure for completion of the results sheets

Some final calculations need to be made before the overall results sheet (see table 25) can be completed. The first of these calculations derives the difference in levels between the wanted signal and the unwanted signal for the stipulated reception (i.e. 14 dB SINAD for analogue speech, 10^{-2} bit error ratio for bit stream or 80 % message acceptance ratio for messages). In all cases, the relevant values can be found on page 2 of the log book results sheet (see table 24) and the resulting level differences are the blocking immunity (or desensitization) values for the EUT.

For analogue speech:

- for all frequencies, the difference (in dB) between the signal generator A level (for 20 dB SINAD) and the level of signal generator B (for 14 dB SINAD) for each temperature/voltage combination should be calculated and entered on page 2 of the log book results sheet (see table 25). The actual calculation is:

$$\text{signal generator B level (for 14 dB SINAD) - signal generator A increased (step 6c) level dB} \quad (7.19)$$

For bit stream:

- for all frequencies, the difference (in dB) between the increased level (Step 6d) of signal generator A and the level of signal generator B (for 10^{-2} BER) for each temperature/voltage combination should be calculated and entered on page 2 of the log book results sheet (see table 25). The actual calculation is:

$$\text{signal generator B level (for } 10^{-2} \text{ BER) - signal generator A increased level (Step 6d) dB} \quad (7.20)$$

For messages:

- for all frequencies, the difference (in dB) between the increased level (Step 6g) of signal generator A and the average level of signal generator B for each temperature/voltage combination should be calculated and entered on page 2 of the log book results sheet (see table 25). The actual calculation is:

$$\text{average signal generator B level - signal generator A increased (Step 6g) level dB} \quad (7.21)$$

For all types of data modulation, the blocking immunity (or desensitization) for the EUT is the lowest of the 40 level differences (eight frequencies, five temperature/voltage combinations) between generators A and B. This lowest value should be entered in the overall results sheet (see table 25).

The final value needed to complete the overall results sheet (see table 25) is the overall measurement uncertainty. This should be calculated in accordance with clause 7.3.11.

7.3.10.4 Log book entries

Table 24: Log book results sheet

BLOCKING IMMUNITY (OR DESENSITIZATION)			Date:	PAGE 1 of 2
Temperature:.....°C		Humidity:.....%		Frequency:.....MHz
Manufacturer of EUT:.....		Type No:.....		Serial No:.....
Test equipment item	Type No.	Serial No.	VSWR	Insertion loss
Digital voltmeter			N/A	N/A
Power supply			N/A	N/A
Ferrite beads (for RF cables)			N/A	N/A
Ferrite beads (for power cables)			N/A	N/A
10 dB attenuator				
Signal generator A				N/A
Signal generator B				N/A
RF cable within climatic facility				
RF cable, climatic facility input to combiner				
RF cable, combiner to sig gen A				
RF cable, combiner to sig gen B				
RF Combiner				
50 Ω load				N/A
Climatic facility			N/A	N/A
Accredited free field test site			N/A	N/A
AF source (if applicable)			N/A	N/A
SINAD meter (if applicable)			N/A	N/A
Acoustic coupler (if applicable)			N/A	N/A
Audio load (if applicable)			N/A	N/A
Bit stream generator (if applicable)			N/A	N/A
Bit error measuring test set (if applicable)			N/A	N/A
Message generator (if applicable)			N/A	N/A
Response measuring test set (if applicable)			N/A	N/A
Mounting configuration of EUT				

BLOCKING IMMUNITY (OR DESENSITIZATION) (analogue speech)				Date: PAGE 2 of 2		
Result of measurement on accredited free field test site:						
Type of test site:.....						
"b)" value of maximum usable sensitivity (dB μ V/m):.....						
Limit of maximum usable sensitivity (as given in relevant standard)(dB μ V/m).....						
Calculated difference between: Limit and measured "b)" values (dB μ V/m).....						
Frequency	Temperature:	T(normal)	T(high)		T(low)	
Sig gen B	Voltage :	V(normal)	V (high)	V (low)	V (high)	V (low)
+1 MHz	Sig gen A (for 20dB SINAD):					
	Increased level of sig gen A:					
	Sig gen B (for 14dB SINAD):					
+2 MHz	Sig gen B (for 14dB SINAD):					
+5 MHz	Sig gen B (for 14dB SINAD):					
+10 MHz	Sig gen B (for 14dB SINAD):					
-1 MHz	Sig gen B (for 14dB SINAD):					
-2 MHz	Sig gen B (for 14dB SINAD):					
-5 MHz	Sig gen B (for 14dB SINAD):					
-10 MHz	Sig gen B (for 14dB SINAD):					
Frequency	Temperature:	T(normal)	T(high)		T(low)	
Sig gen B	Voltage :	V(normal)	V (high)	V (low)	V (high)	V (low)
+1 MHz	Sig gen A - Sig gen B :					
+2 MHz	Sig gen A - Sig gen B :					
+5 MHz	Sig gen A - Sig gen B :					
+10 MHz	Sig gen A - Sig gen B :					
-1 MHz	Sig gen A - Sig gen B :					
-2 MHz	Sig gen A - Sig gen B :					
-5 MHz	Sig gen A - Sig gen B :					
-10 MHz	Sig gen A - Sig gen B :					

BLOCKING IMMUNITY (OR DESENSITIZATION) (bit stream)				Date: PAGE 2 of 2		
Result of measurement on accredited free field test site:						
Type of test site:.....						
"b)" value of maximum usable sensitivity (dB μ V/m):.....						
Limit of maximum usable sensitivity (as given in relevant standard)(dB μ V/m).....						
Calculated difference between: Limit and measured "b)" values (dB μ V/m).....						
Frequency	Temperature:	T(normal)	T(high)		T(low)	
Sig gen B	Voltage:	V(normal)	V (high)	V (low)	V (high)	V (low)
+1 MHz	Sig gen A (for 10 ⁻² BER):					
	Increased level of sig gen A:					
	Sig gen B (for 10 ⁻² BER):					
+2 MHz	Sig gen B (for 10 ⁻² BER):					
+5 MHz	Sig gen B (for 10 ⁻² BER):					
+10 MHz	Sig gen B (for 10 ⁻² BER):					
-1 MHz	Sig gen B (for 10 ⁻² BER):					
-2 MHz	Sig gen B (for 10 ⁻² BER):					
-5 MHz	Sig gen B (for 10 ⁻² BER):					
-10 MHz	Sig gen B (for 10 ⁻² BER):					
Frequency	Temperature:	T(normal)	T(high)		T(low)	
Sig gen B	Voltage:	V(normal)	V (high)	V (low)	V (high)	V (low)
+1 MHz	Sig gen A - Sig gen B :					
+2 MHz	Sig gen A - Sig gen B :					
+5 MHz	Sig gen A - Sig gen B :					
+10 MHz	Sig gen A - Sig gen B :					
-1 MHz	Sig gen A - Sig gen B :					
-2 MHz	Sig gen A - Sig gen B :					
-5 MHz	Sig gen A - Sig gen B :					
-10 MHz	Sig gen A - Sig gen B :					

BLOCKING IMMUNITY (OR DESENSITIZATION) (messages)		Date: PAGE 2 of 2				
Result of measurement on accredited free field test site:						
Type of test site:.....						
"b)" value of maximum usable sensitivity (dB μ V/m):.....						
Limit of maximum usable sensitivity (as given in relevant standard)(dBμV/m).....						
Calculated difference between: Limit and measured "b)" values (dBμV/m).....						
Frequency	Temperature:	T(normal)	T(high)		T(low)	
Sig gen B	Voltage:	V(normal)	V (high)	V (low)	V (high)	V (low)
+1 MHz	Signal generator A level 1:					
	Signal generator A level 2:					
	Signal generator A level 3:					
	Signal generator A level 4:					
	Signal generator A level 5:					
	Signal generator A level 6:					
	Signal generator A level 7:					
	Signal generator A level 8:					
	Signal generator A level 9:					
	Signal generator A level 10:					
	Average sig gen A output:					
	Increased level of sig gen A					
	Signal generator B level 1:					
	Signal generator B level 2:					
	Signal generator B level 3:					
	Signal generator B level 4:					
	Signal generator B level 5:					
	Signal generator B level 6:					
	Signal generator B level 7:					
	Signal generator B level 8:					
	Signal generator B level 9:					
	Signal generator B level 10:					
	Average sig gen A output:					
+2 MHz	Signal generator B level 1:					
	Signal generator B level 2:					
	Signal generator B level 3:					
	Signal generator B level 4:					
	Signal generator B level 5:					
	Signal generator B level 6:					
	Signal generator B level 7:					
	Signal generator B level 8:					
	Signal generator B level 9:					
	Signal generator B level 10:					
	Average sig gen A output:					
+5 MHz	Signal generator B level 1:					
	Signal generator B level 2:					
	Signal generator B level 3:					
	Signal generator B level 4:					
	Signal generator B level 5:					
	Signal generator B level 6:					
	Signal generator B level 7:					
	Signal generator B level 8:					
	Signal generator B level 9:					
	Signal generator B level 10:					
	Average sig gen A output:					
+10 MHz	Signal generator B level 1:					
	Signal generator B level 2:					
	Signal generator B level 3:					
	Signal generator B level 4:					
	Signal generator B level 5:					
	Signal generator B level 6:					
	Signal generator B level 7:					
	Signal generator B level 8:					
	Signal generator B level 9:					
	Signal generator B level 10:					

BLOCKING IMMUNITY (OR DESENSITIZATION) (messages)		Date: PAGE 2 of 2				
Result of measurement on accredited free field test site:						
Type of test site:.....						
"b" value of maximum usable sensitivity (dB μ V/m):.....						
Limit of maximum usable sensitivity (as given in relevant standard)(dB μ V/m).....						
Calculated difference between: Limit and measured "b" values (dB μ V/m).....						
Frequency	Temperature:	T(normal)	T(high)	T(low)		
Sig gen B	Voltage:	V(normal)	V (high)	V (low)	V (high)	V (low)
	Average sig gen A output:					
-1 MHz	Signal generator B level 1:					
	Signal generator B level 2:					
	Signal generator B level 3:					
	Signal generator B level 4:					
	Signal generator B level 5:					
	Signal generator B level 6:					
	Signal generator B level 7:					
	Signal generator B level 8:					
	Signal generator B level 9:					
	Signal generator B level 10:					
	Average sig gen A output:					
-2 MHz	Signal generator B level 1:					
	Signal generator B level 2:					
	Signal generator B level 3:					
	Signal generator B level 4:					
	Signal generator B level 5:					
	Signal generator B level 6:					
	Signal generator B level 7:					
	Signal generator B level 8:					
	Signal generator B level 9:					
	Signal generator B level 10:					
	Average sig gen A output:					
-5 MHz	Signal generator B level 1:					
	Signal generator B level 2:					
	Signal generator B level 3:					
	Signal generator B level 4:					
	Signal generator B level 5:					
	Signal generator B level 6:					
	Signal generator B level 7:					
	Signal generator B level 8:					
	Signal generator B level 9:					
	Signal generator B level 10:					
	Average sig gen A output:					
-10 MHz	Signal generator B level 1:					
	Signal generator B level 2:					
	Signal generator B level 3:					
	Signal generator B level 4:					
	Signal generator B level 5:					
	Signal generator B level 6:					
	Signal generator B level 7:					
	Signal generator B level 8:					
	Signal generator B level 9:					
	Signal generator B level 10:					
	Average sig gen A output:					
+1 MHz	Sig gen A - Sig gen B :					
+2 MHz	Sig gen A - Sig gen B :					
+5 MHz	Sig gen A - Sig gen B :					
+10 MHz	Sig gen A - Sig gen B :					
-1 MHz	Sig gen A - Sig gen B :					
-2 MHz	Sig gen A - Sig gen B :					
-5 MHz	Sig gen A - Sig gen B :					
-10 MHz	Sig gen A - Sig gen B :					

7.3.10.5 Overall results sheet

The results should be presented in tabular form as shown in table 25.

Table 25: Overall results sheet

BLOCKING IMMUNITY (OR DESENSITIZATION)		Date:	PAGE 1 of 1
Blocking immunity (or desensitization)			dB
Expanded uncertainty (95 %)			dB

7.3.11 Measurement uncertainty for blocking immunity (or desensitization)

All the uncertainty contributions for the test are listed in table 26.

Table 26: Contributions from the measurement

$u_{j \text{ or } i}$	Description of uncertainty contributions	dB
u_{j60}	Test Fixture: climatic facility effect on the EUT	
u_{j61}	Test Fixture: effect on the EUT	
u_{j01}	random uncertainty (see note in clause A.18 of TR 102 273-1-2 and note in clause 6.4.7 of TR 102 273-1-1)	
u_{j38}	signal generator A: absolute output level	
u_{j38}	signal generator B: absolute output level	
u_{j39}	signal generator A: output level stability	0,00
u_{j39}	signal generator B: output level stability	0,00

The standard uncertainties from table 26 should be given values according to annex A of TR 102 273-1-1 [4]. They should then be combined by RSS in accordance with clause 5 of TR 102 273-1-1 [4]. This gives the combined standard uncertainty (u_c contributions from the measurement) for the EUT measurement in dB.

7.3.11.1 Expanded uncertainty of the blocking immunity (or desensitization) measurement

Tests in a Test Fixture differ to radiated tests on all other types of site in that there is only one stage to the test. However, to calculate the measurement uncertainty, the Test Fixture measurement should be considered as stage two of a test in which stage one was on an accredited free field test site. The combined standard uncertainty, u_c , of the blocking immunity (or desensitization) measurement is therefore, simply the RSS combination of the value for u_c contributions from the measurement derived above and the combined uncertainty of the free field test site u_c contribution from the free field test site:

$$u_c = \sqrt{u_{c \text{ contributions from the measurement}}^2 + u_{c \text{ contributions from the free-field test site}}^2} = _, _ \text{ dB} \quad (7.22)$$

The expanded uncertainty is $\pm 1,96 \times u_c = \pm _, _ \text{ dB}$ at a 95 % confidence level.

7.3.12 Spurious response rejection

This test is not performed at extreme conditions. Therefore the test is not carried out in a Test Fixture.

Annex A: Bibliography

- "Advanced National certificate mathematics", PEDOE, Hodder and Stoughton Volumes I and II.
- "Antenna engineering handbook", R. C. Johnson, H. Jasik.
- "Antennas and radio wave propagation", R. E. Collin, McGraw Hill.
- "Antennas", John D. Kraus, Second edition, McGraw Hill.
- "Antenna Theory: Analysis and Design", 2nd Edition, Constantine A. Balanis (1996).
- "Chambers Science and Technology dictionary", 1988. Published by Chambers Cambridge.
- "A designers guide to shielding", Hewlett Packard: RF and microwave measurement symposium and exhibition.
- "Analysis of trials on Artificial Human Body", I. L. Gallan and P. R. Brown Interference technology international consultants ltd. Contract ref MC/078.
- "Calculation of site attenuation from antenna factors" A. A. Smith Jr, RF German and J B Pate. IEEE transactions EMC. Vol. EMC 24 pp 301-316 Aug 1982.
- "Computer simulation and measurements of electromagnetic fields close to phantom Humans", Electricity and magnetism in biology and medicine by Martin Blank, Ed 1993 San Francisco Press.
- "Control of errors on Open Area Test Sites", A. A. Smith Jnr. EMC technology October 1982 pages 50-58.
- "Digital Communications", John G. Proakis, McGraw-Hill International Editions, second edition.
- "The expression of uncertainty in electrical measurement", B3003, November 1987 National Measurement Accreditation Service (NAMAS).
- "Fundamentals of RF and Microwave Power Measurements", Hewlett Packard: Application note 64-1 August 1977.
- "The gain resistance product of the half-wave dipole", W. Scott Bennet Proceedings of IEEE vol. 72 No. 2 Dec 1984 pp 1824-1826.
- "Getting better results from an Open Area Test Site", Joseph DeMarinus.
- "Guide to the evaluation and expression of the uncertainties associated with the results of electrical measurements", Ministry of Defence: 00-26/Issue 2: September 1988.
- "Guide to the Expression of Uncertainty in Measurement" (International Organization for standardization, Geneva, Switzerland, 1995).
- "Measurement uncertainty generally", Statens Tekniske Provenaeavn, The Danish Accreditation Committee (STP). June 1988 (Danish).
- "The new IEEE standard dictionary of electrical and electronic terms". Fifth edition, IEEE Piscataway, NJ USA 1993.
- "Specifications for equipment's for use in the Land Mobile Service" CEPT Recommendation T/R 24-01.
- "Techniques for measuring narrowband and broadband EMI signals using spectrum analysers", Hewlett Packard RF and microwave measurement symposium and exhibition.
- "Uncertainties of Measurement for NATLAS electrical testing laboratories. NAMAS policy and general notes", National Testing Laboratory Accreditation Scheme (NATLAS), NIS20 July 1986 (English).
- "Use of Simulated Human Bodies in pager receiver sensitivity measurements", K.Siwiak and W.Elliott III. Southcom /92 conference, Orlando 1992. pp 189/92.

- "Usikkerhed pa maleresultater" (Per Bennich, Institute for Product Development : "Uncertainty of measured results"). October 1988. (Danish).
- "Standard site method for determining antenna factors", A. A. Smith Jr. IEEE transactions EMC. Vol EMC 24 pp 316-322 Aug 1982.
- 50(161) IEC 1990.
- "Radiowave propagation and antennas for personal communications" K. Siwiak, Artech House Publications.
- "The telecommunications factbook and illustrated dictionary", Kahn, Delmar publications Inc. New York 1992.
- "Vocabulary of metrology", British standard Institution (BSI) : PD 6461 : Part 2 : September 1980.
- "Wave transmission", F. R. Conner, Arnold 1978.

History

Document history		
Edition 1	February 1998	Publication as ETR 273-6
V1.2.1	December 2001	Publication