

Digital Video Broadcasting (DVB); DVB-H Implementation Guidelines

European Broadcasting Union



Union Européenne de Radio-Télévision



Reference

RTR/JTC-DVB-247

Keywordsbroadcasting, digital, DVB, DVB-H, IP, terrestrial,
TV, video**ETSI**

650 Route des Lucioles
F-06921 Sophia Antipolis Cedex - FRANCE

Tel.: +33 4 92 94 42 00 Fax: +33 4 93 65 47 16

Siret N° 348 623 562 00017 - NAF 742 C
Association à but non lucratif enregistrée à la
Sous-Préfecture de Grasse (06) N° 7803/88

Important notice

Individual copies of the present document can be downloaded from:

<http://www.etsi.org>

The present document may be made available in more than one electronic version or in print. In any case of existing or perceived difference in contents between such versions, the reference version is the Portable Document Format (PDF). In case of dispute, the reference shall be the printing on ETSI printers of the PDF version kept on a specific network drive within ETSI Secretariat.

Users of the present document should be aware that the document may be subject to revision or change of status. Information on the current status of this and other ETSI documents is available at

<http://portal.etsi.org/tb/status/status.asp>

If you find errors in the present document, please send your comment to one of the following services:

http://portal.etsi.org/chaicor/ETSI_support.asp

Copyright Notification

No part may be reproduced except as authorized by written permission.
The copyright and the foregoing restriction extend to reproduction in all media.

© European Telecommunications Standards Institute 2009.

© European Broadcasting Union 2009.

All rights reserved.

DECT[™], **PLUGTESTS**[™], **UMTS**[™], **TIPHON**[™], the TIPHON logo and the ETSI logo are Trade Marks of ETSI registered for the benefit of its Members.

3GPP[™] is a Trade Mark of ETSI registered for the benefit of its Members and of the 3GPP Organizational Partners.

LTE[™] is a Trade Mark of ETSI currently being registered for the benefit of its Members and of the 3GPP Organizational Partners.

GSM[®] and the GSM logo are Trade Marks registered and owned by the GSM Association.

Contents

Intellectual Property Rights	7
Foreword.....	7
Introduction	7
1 Scope	9
2 References	9
2.1 Normative references	9
2.2 Informative references.....	10
3 Definitions, symbols and abbreviations	10
3.1 Definitions	10
3.2 Symbols.....	11
3.3 Abbreviations	12
4 DVB-H system outline	13
4.1 Overview of the system.....	13
4.2 Time slicing.....	15
4.3 MPE-FEC	16
4.4 Additional 4K mode and in-depth interleavers.....	16
4.5 DVB-H Signalling	17
5 Link layer elements: time slicing and MPE-FEC.....	17
5.1 Description of the main issues.....	17
5.1.1 Power consumption.....	17
5.1.2 Handover	17
5.1.3 RF performance for mobile single antenna reception	17
5.2 How time slicing and MPE-FEC provide a solution	18
5.2.1 Power consumption.....	18
5.2.2 Handover	19
5.2.3 RF performance for mobile single antenna reception	19
5.2.4 Time slicing and MPE-FEC used together	20
5.3 Time slicing implementation.....	20
5.3.1 Receiver	20
5.3.2 Protocol stack.....	20
5.3.3 Implementation in the Link layer.....	21
5.3.4 Delta-t method	21
5.3.5 Burst Size and Off-time	23
5.3.6 Handover support.....	25
5.3.7 Mixing Time Sliced elementary streams into a multiplex	26
5.3.8 Time slicing of PSI/SI.....	27
5.4 MPE-FEC implementation	28
5.4.1 MPE-FEC frame	28
5.4.1.1 Definition of MPE-FEC frame	28
5.4.1.2 Application data table	28
5.4.1.3 RS data table	29
5.4.2 Carriage of MPE-FEC frame	30
5.4.2.1 Carriage of Application data table datagrams	30
5.4.2.2 Carriage of parity bytes in RS data table.....	30
5.4.3 RS decoding.....	30
5.4.3.1 Basic functionality	30
5.4.3.2 Application data padding columns - Code shortening	31
5.4.3.3 Discarding RS data columns - Puncturing	31
5.5 Complexity and Cost considerations	31
5.6 Time slicing and Conditional Access	31
5.7 Memory issues.....	32
5.7.1 Memory usage	32
5.7.2 MPE-FEC memory size and receiver constraints	33

5.7.3	Minimum memory requirements	33
5.7.4	Conclusion	35
6	Physical layer elements: TPS bits, 4K mode and in-depth interleavers	35
6.1	4K mode	35
6.1.1	General considerations.....	35
6.1.2	Performance description	36
6.1.3	Complexity, Cost and other Commercial Requirements considerations.....	37
6.2	In-depth interleaver for 2K and 4K modes	38
6.3	TPS-bit Signalling	38
7	DVB-H/DVB-T compatibility issues	39
7.1	Time slicing and MPE-FEC	39
7.2	DVB-H signalling.....	39
7.3	Added 4K mode and in-depth interleavers	39
8	DVB-H services	40
8.1	Service scenarios	40
8.1.1	Effects of the Environment and equipment.....	40
8.1.1.1	Slow moving DVB-H terminal	40
8.1.1.2	DVB-H in fast moving mobile	40
8.1.2	Services.....	41
8.1.2.1	Real-time Applications.....	41
8.1.2.2	Near on-demand Applications.....	42
8.1.2.3	Downloaded Applications	42
8.1.2.4	Other added-value services and applications	43
8.2	Hierarchical networks for progressive QoS degradation or multiformat/multidevice support	43
8.2.1	Introduction.....	43
8.2.2	Network planning considerations	44
8.2.3	Scenario	44
8.2.3.1	Progressive degradation of the QoS	44
8.2.3.2	Multiformat/multidevice support	45
8.2.3.3	Utilization of LP stream for upgrading content carried within HP stream.....	45
8.3	Sharing aspects with DVB-T MPEG-2 services.....	46
8.3.1	Multiplexing	46
8.3.2	Hierarchical Modulation	48
8.4	DVB-H service access	49
8.5	Handover considerations	50
8.5.1	Requirements	50
8.5.2	Signal scan	51
8.5.3	Use of NIT and frequency_list_descriptor	52
8.5.4	Cell identification via TPS and NIT	52
8.5.5	Use of INT tables.....	53
8.5.6	Time slice synchronization for seamless handover support.....	56
8.5.6.1	Phase shifting	56
8.5.6.2	IP Encapsulators synchronization	57
8.6	Consecutive and parallel transmission schemes of elementary streams and services	57
8.6.1	Transmission schemes of elementary streams	57
8.6.2	How to set up parallel elementary streams and services?	58
8.6.3	Features of consecutive and parallel elementary streams	58
8.6.3.1	Power consumption	58
8.6.3.2	Fast channel zapping and reception of multiple services	60
8.6.3.3	Transmission schemes and physical-layer performance	60
8.6.3.4	Receive low speed services at the same time as main services (ESG update, Alarms, Alerts, Emergencies, etc.)	61
8.6.3.5	Local insertion of services	61
8.6.3.6	Optimization of the bitrate	61
8.6.4	Elementary streams with multiple services.....	63
8.7	Considerations on channel switching	63
8.8	The Dynamic Zapping Service	65
8.8.1	Introduction.....	65
8.8.2	Two use cases	65
8.8.3	Generation of the dynamic zapping service.....	65

8.8.4	MPE encapsulation and multiplexing	65
8.8.5	PSI/SI considerations	66
8.8.6	Terminal behaviour examples	67
8.8.7	Bit rate calculations	67
9	DVB-H networks	68
9.1	Considerations on Network configuration	68
9.1.1	Introduction	68
9.1.2	DVB-H FFT modes	68
9.1.2.1	Indoor handheld reception (at no speed)	68
9.1.2.2	Outdoor handheld reception (moderate to high speed)	68
9.1.3	DVB-H parameters	69
9.1.3.1	Physical layer parameters	69
9.1.3.2	Link layer parameters	69
9.1.3.2.1	Introduction	69
9.1.3.2.2	Receiver synchronization time	70
9.1.3.2.3	Power consumption figures	71
9.1.3.2.4	Time slicing period & MPE-FEC burst size equations	72
9.2	Dedicated DVB-H networks	73
9.3	Service Information issues	73
9.4	Considerations on the use of repeaters in DVB-H networks	75
9.4.1	On-channel repeaters	75
9.4.2	Frequency synchronized transposing repeaters	77
9.5	Guidelines for the use of DVB-H in 5 MHz channel bandwidth	79
9.5.1	Modulation Parameters	79
9.5.1.1	Symbol Period	79
9.5.1.2	Phase Noise	79
9.5.1.3	Doppler Shift	79
9.5.2	Network Planning Considerations	80
10	Reference Receiver	80
10.1	Foreword on expected performance	80
10.1.1	Service aspects	81
10.2	DVB-H reference receiver model	82
10.3	Minimum receiver signal input levels for planning	82
10.3.1	Noise Floor	82
10.3.2	Minimum C/N-requirements	83
10.3.2.1	DVB-H degradation criterion	83
10.3.2.2	C/N Performance in Gaussian Channel	83
10.3.2.3	C/N Performance in DVB-T Rayleigh channel (P1)	84
10.3.2.4	C/N Performance in portable indoor (PI) and portable outdoor (PO) channels	84
10.3.2.5	C/N performance in Mobile Channels	85
10.3.3	Minimum Input Levels	86
10.4	Antenna issues for DVB-H Handheld terminals	87
10.4.1	Integrated antenna	87
10.4.2	External antenna	87
10.5	Diversity reception	88
11	Network planning	88
11.1	Coverage definitions	88
11.1.1	Introduction	88
11.1.2	Portable reception	88
11.1.3	Mobile reception	89
11.1.4	Coverage area	89
11.2	Minimum field strength considerations	90
11.2.1	Minimum receiver signal input level	90
11.2.2	Planning Criteria	91
11.2.2.1	Minimum signal levels	91
11.2.2.2	Portable antenna reception	92
11.2.2.2.1	Criteria for portable outdoor reception	92
11.2.2.2.2	Criteria for portable indoor reception	94
11.2.2.3	Mobile reception	95
11.2.3	Signals levels for DVB-H planning	96

11.2.3.1	Portable reception	96
11.2.3.2	Mobile reception	98
Annex A:	Terminal categories	101
Annex B:	Interoperability with Cellular Radios.....	102
B.1	General issues.....	102
B.2	Cellular Radio Uplink Wanted Signal Interference to DVB-H Receiver.....	103
B.3	Cellular Radio Uplink Unwanted Signal Interference to DVB-H Receiver.....	104
B.4	Supported frequency range.....	105
Annex C:	DVB-H link layer parameter selection.....	106
C.1	Introduction	106
C.2	Parameter set number 1	107
C.3	Parameter set number 2	108
C.4	Parameter set number 3	109
C.5	Parameter set number 4	110
Annex D:	Channel models for DVB-H	111
D.1	Portable Indoor and Outdoor Channels (PI & PO).....	111
D.2	Mobile Channel (TU-6).....	112
Annex E:	Bibliography	113
History	114

Intellectual Property Rights

IPRs essential or potentially essential to the present document may have been declared to ETSI. The information pertaining to these essential IPRs, if any, is publicly available for **ETSI members and non-members**, and can be found in ETSI SR 000 314: "*Intellectual Property Rights (IPRs); Essential, or potentially Essential, IPRs notified to ETSI in respect of ETSI standards*", which is available from the ETSI Secretariat. Latest updates are available on the ETSI Web server (<http://webapp.etsi.org/IPR/home.asp>).

Pursuant to the ETSI IPR Policy, no investigation, including IPR searches, has been carried out by ETSI. No guarantee can be given as to the existence of other IPRs not referenced in ETSI SR 000 314 (or the updates on the ETSI Web server) which are, or may be, or may become, essential to the present document.

Foreword

This Technical Report (TR) has been produced by Joint Technical Committee (JTC) Broadcast of the European Broadcasting Union (EBU), Comité Européen de Normalization ELECTrotechnique (CENELEC) and the European Telecommunications Standards Institute (ETSI).

The present document is supplementary to the earlier document TR 101 190 [i.5]. The present document extends the scope of the implementation guidelines to include handheld reception as defined by EN 302 304 [i.2]. Many of the items specified in TR 101 190 [i.5] are not reproduced in the present document, as they are already available, even though they may be relevant to the implementation of a DVB-H network.

NOTE: The EBU/ETSI JTC Broadcast was established in 1990 to co-ordinate the drafting of standards in the specific field of broadcasting and related fields. Since 1995 the JTC Broadcast became a tripartite body by including in the Memorandum of Understanding also CENELEC, which is responsible for the standardization of radio and television receivers. The EBU is a professional association of broadcasting organizations whose work includes the co-ordination of its members' activities in the technical, legal, programme-making and programme-exchange domains. The EBU has active members in about 60 countries in the European broadcasting area; its headquarters is in Geneva.

European Broadcasting Union
CH-1218 GRAND SACONNEX (Geneva)
Switzerland
Tel: +41 22 717 21 11
Fax: +41 22 717 24 81

Founded in September 1993, the DVB Project is a market-led consortium of public and private sector organizations in the television industry. Its aim is to establish the framework for the introduction of MPEG-2 based digital television services. Now comprising over 200 organizations from more than 25 countries around the world, DVB fosters market-led systems, which meet the real needs, and economic circumstances, of the consumer electronics and the broadcast industry.

Introduction

The present document gives the first guidelines for the implementation of Digital Video Broadcasting Handheld (DVB-H) transmission networks.

The document describes the main features of the DVB-H system and gives guidelines for setting up networks and services.

Updates to the present document will be produced when more results from DVB-H compliant hardware tests and experience from field trials become available.

Document summary

An outline of the DVB-H system is introduced in clause 4, describing the main features of time slicing, multiprotocol encapsulation forward error correction (MPE-FEC), the additional (to DVB-T) 4K mode and in-depth interleavers, and DVB-H signalling.

Clause 5 introduces the link layer elements of the DVB-H system specification. These are time slicing and MPE-FEC. In this clause there is a description of the main issues and a discussion on how to implement the DVB-H elements.

Clause 6 introduces the physical layer elements of the DVB-H system specification that are additional to the DVB-T standard.

NOTE: As seen in the main text, time slicing and DVB-H signalling is mandatory in a DVB-H system. Other technological elements are optional to use.

Compatibility issues (to DVB-T) are discussed in detail in clause 7.

DVB-H services and usage scenarios are presented in clause 8. This clause includes important issues such as sharing with DVB-T and MPEG-2 services and handover considerations.

Clause 9 is devoted to DVB-H networks. The following issues are discussed: Network configurations, SI issues, on-channel repeaters and general guidelines for the use of DVB-H in 5 MHz channel bandwidths.

Clauses 10 and 11 provide preliminary information about the DVB-H reference receiver and network planning.

Finally two annexes are included, the first shows the terminal categories (used in clause 11) and the other outlines the implications of having "convergence terminals" in which DVB-H and GSM/UMTS technologies co-exist.

1 Scope

The present document provides guidelines for the use and implementation of ETSI Digital Video Broadcasting Handheld (DVB-H) standard [i.2] in the context of providing an efficient way of carrying multimedia services over digital terrestrial broadcasting networks to handheld terminals.

The document should be read in conjunction with the DVB-T Implementation Guidelines (TR 101 190 [i.5]) since many transmission aspects and network topologies (e.g. Single Frequency Networks and Multi-Frequency Networks) are not described in detail in the present document because DVB-H is built upon DVB-T.

Objective

- The present document describes the Digital Video Broadcasting Handheld (DVB-H) specification for digital terrestrial TV broadcasting to handheld portable/mobile terminals. It draws attention to the technical questions that need to be answered when setting up DVB-H services and networks plus it offers some guidance in finding answers to them. It does not cover in detail, issues linked to the content of the broadcasts such as Coding Formats, Electronic Programme Guides (EPG), Access Control (CA), etc.

Target readers

- The present document is aimed at the Technical Departments of broadcasting organizations that are considering implementing digital terrestrial broadcasting to handheld devices. It assumes that readers are familiar with digital terrestrial broadcasting networks.

Contributors

- The present document was prepared by members of the Ad-hoc group TM-H from the DVB Project. Members include broadcasters, network operators and professional and domestic equipment manufacturers.

2 References

References are either specific (identified by date of publication and/or edition number or version number) or non-specific.

- For a specific reference, subsequent revisions do not apply.
- Non-specific reference may be made only to a complete document or a part thereof and only in the following cases:
 - if it is accepted that it will be possible to use all future changes of the referenced document for the purposes of the referring document;
 - for informative references.

Referenced documents which are not found to be publicly available in the expected location might be found at <http://docbox.etsi.org/Reference>.

NOTE: While any hyperlinks included in this clause were valid at the time of publication ETSI cannot guarantee their long term validity.

2.1 Normative references

The following referenced documents are indispensable for the application of the present document. For dated references, only the edition cited applies. For non-specific references, the latest edition of the referenced document (including any amendments) applies.

Not applicable.

2.2 Informative references

The following referenced documents are not essential to the use of the present document but they assist the user with regard to a particular subject area. For non-specific references, the latest version of the referenced document (including any amendments) applies.

- [i.1] ETSI EN 300 744: "Digital Video Broadcasting (DVB); Framing structure, channel coding and modulation for digital terrestrial television".
- [i.2] ETSI EN 302 304: "Digital Video Broadcasting (DVB); Transmission System for Handheld Terminals (DVB-H)".
- [i.3] ETSI TR 101 211: "Digital Video Broadcasting (DVB); Guidelines on implementation and usage of Service Information (SI)".
- [i.4] ETSI EN 300 468: "Digital Video Broadcasting (DVB); Specification for Service Information (SI) in DVB systems".
- [i.5] ETSI TR 101 190: "Digital Video Broadcasting (DVB); Implementation guidelines for DVB terrestrial services; Transmission aspects".
- [i.6] ETSI EN 301 192: "Digital Video Broadcasting (DVB); DVB specification for data broadcasting".
- [i.7] IEC 62002-1: "Mobile and Portable DVB-T/H Radio Access - Part 1: Interface Specification".
- [i.8] ISO/IEC 7498-1: "Information technology - Open Systems Interconnection - Basic Reference Model: The Basic Model".
- [i.9] ISO/IEC 13818-1: "Information technology - Generic coding of moving pictures and associated audio information: Systems".
- [i.10] ITU-R Recommendation P.1546-1: "Method for point-to-area predictions for terrestrial services in the frequency range 30 MHz to 3 000 MHz".
- [i.11] ITU-T Recommendation P.370: "Coupling Hearing Aids to Telephone sets".
- [i.12] ETSI TS 100 910: "Digital cellular telecommunications system (Phase 2+); Radio Transmission and Reception (3GPP TS 05.05)".

3 Definitions, symbols and abbreviations

3.1 Definitions

For the purposes of the present document, the following terms and definitions apply:

burst size: number of Network Layer bits within a time sliced burst

cycle time: time between the beginning of two consecutive bursts of the same Elementary Stream

datagram: network layer packet with full address information enabling it to be routed to the endpoint without further information

DVB-H services: content carried by the DVB-H system

elementary stream: stream of transport packets within a transport stream sharing a common Packet Identifier (PID)

NOTE: The "elementary stream" definition differs from the MPEG-2 one.

IP datagram stream: stream of IP datagrams each sharing the same IP source and destination address

NOTE: An IP datagram stream is identified within an IP platform by its source and destination addresses. IP datagram streams on different IP platforms may have the same source/destination addresses, but are considered different IP datagram streams. IP datagram streams may be delivered over one or multiple IP streams.

IP/MAC stream: data stream including an address header containing an IP and/or MAC address

NOTE: IP/MAC stream is encapsulated in an MPEG-2 Transport Stream multiplex. An example would be an IP multicast stream conveyed in MPE sections.

IP platform: set of IP datagram stream managed by an organization

NOTE: The IP platform represents a harmonized IP address space that has no address collisions. An IP platform may span several transport streams within one or multiple DVB networks. Several IP platforms may co-exist in the same transport stream.

IP service: collection of service elements, each carried on an IP datagram stream

MPE-FEC: method to deliver additional Forward Error Correction to datagrams delivered in MPE sections, as defined in EN 301 192 [i.6]

network layer: OSI layer as defined in ISO/IEC 7498-1 [i.8]

off-time: time between two time sliced bursts

NOTE: During the off-time, no transport_packets are delivered on the relevant elementary stream.

soft handover: receiver receiving transport stream, switches to another transport stream and continues receiving the previously received IP service(s)

NOTE: Switching is accomplished seamlessly without interruption of the service consumption. Note that a soft handover is neither required nor possible if no services are currently being consumed.

time slicing: method to deliver MPE sections and MPE-FEC sections in bursts, as defined in EN 301 192 [i.6]

transport_packet: data structure defined in ISO/IEC 13818-1 [i.9]

transport stream: stream of transport_packets, as defined in ISO/IEC 13818-1 [i.9]

3.2 Symbols

For the purposes of the present document, the following symbols apply:

B	Receiver noise bandwidth (Hz)
B _b	Burst Bitrate (bits per second)
B _d	Burst Duration (seconds)
B _s	Burst Size (bits)
C _a	ECM synchronization time (seconds)
C _b	Constant Bitrate (bits per second)
C _l	Location correction factor (dB)
C/N	RF signal to noise ratio required by the system (dB)
D _j	Delta-t Jitter (seconds)
E _{med}	Minimum median equivalent field strength, planning value (dBμV/m)
E _{min}	Equivalent minimum field strength at receiving location (dBμV/m)
F	Receiver noise figure (dB)
k	Boltzmann's constant = $1,38 \times 10^{-23}$ J/K
L _b	Building penetration loss (dB)
L _h	Height loss (10 m a.g.l. to 1,5 m. a.g.l.) (dB)
L _v	Vehicle entry loss (dB)
O _t	Off-time (seconds)
P _{mmn}	Allowance for manmade noise (dB)

P_n	Receiver noise input power (dBW)
P_s	Power Saving (Watts)
$P_{s_{\min}}$	Minimum receiver signal input power (dBW)
T_s	Synchronization Time (seconds)
Rx	Receiver
T_0	absolute Temperature = 290 K
Tx	Transmitter
$U_{s_{\min}}$	Minimum equivalent receiver input voltage into Z_i (dB μ V)
Z_i	Receiver input impedance (75 Ω)
ϕ_{\min}	Minimum power flux density at receiving location (dBW/m ²)
ϕ_{med}	Minimum median power flux density, planning value (dBW/m ²)

3.3 Abbreviations

For the purposes of the present document, the following abbreviations apply:

AGC	Amplitude Gain Control
AVC	Audio Video Coding
AWGN	Additive White Gaussian Noise
BAT	Bouquet Association Table
BB	BaseBand
BER	Bit Error Ratio
C/N	Carrier to Noise ratio
CA	Conditional Access
CAS	Conditional Access System
CEPT	European Conference of Postal and Telecommunications administrations
CIF	Common Image Format
CM	Commercial Module
COFDM	Coded Orthogonal Frequency Division Multiplexing
CRC	Cyclic Redundancy Check
DTT	Digital Terrestrial Television
DVB	Digital Video Broadcasting
DVB-H	DVB Handheld
DVB-T	DVB Terrestrial
ECM	Entitlement Control Message
EIT	Event Information Table
EMM	Entitlement Management Messages
EPG	Electronic Program Guide
ES	Elementary Stream
ESG	Electronic Service Guide
FEC	Forward Error Correcting code
FFT	Fast Fourier Transform
G.I.	Guard Interval
GOP	Group of Pictures
GPS	Global Positioning System
HP	High Priority stream
ID	IDentifier
IFFT	Inverse Fast Fourier Transform
INT	IP/MAC Notification Table
IP	Internet Protocol
IPDC	IP Datacasting
IPE	IP Encapsulator
IRD	Integrated Receiver Decoder
ITU	International Telecommunication Union
LP	Low Priority stream
MAC	Media Access Control
MFER	MPE-FEC Frame Error Ratio
MFN	Multi-Frequency Network
MIP	Mega-frame Initialization Packet
MPE	MultiProtocol Encapsulation

MPE-FEC	MultiProtocol Encapsulation-Forward Error Correction
MPEG	Moving Picture Experts Group
MUX	MULTipleX, MULTipleXer
NIT	Network Information Table
OFDM	Orthogonal Frequency Division Multiplex
OSI	Open System Interconnection
PA	Power Amplifier
PAT	Program Association Table
PCR	Program Clock Reference
PDA	Personal Digital Assistant
PID	Packet IDentifier
PLL	Phased Locked Loop
PLR	Packet Loss Ratio
PMT	Program Map Table
PSI	Program Specific Information
QAM	Quadrature Amplitude Modulation
QCIF	Quarter Common Image Format
QEF	Quasi Error Free
QoS	Quality of Service
QPSK	Quadrature Phase Shift Keying
RF	Radio Frequency
RS	Reed-Solomon
SDT	Service Description Table
SER	Section Error Ratio
SFN	Single Frequency Network
SI	Service Information
TDM	Time Division Multiplex
TPS	Transmission Parameter Signalling
TS	Transport Stream
TV	TeleVision
UHF	Ultra-High Frequency (300 MHz to 3 000 MHz)
VHF	Very High Frequency (30 MHz to 300 MHz)

4 DVB-H system outline

4.1 Overview of the system

To meet the Commercial Requirements set by the DVB-M (CM) group for a new DVB transport mechanism, a Call for Technologies was released by the DVB in January 2003. Based on the responses received and using the technology elements of several proposals (plus some development work carried out inside the DVB-H group) a full DVB-H concept has been composed by combining elements in the Physical and Link layers. The DVB-H group took into account the guidance and requests set by the DVB-TM and DVB-SB for the new standard.

Although the DVB-T transmission system has proven its ability to serve fixed, portable and mobile terminals; handheld terminals (defined as light-weight, battery-powered apparatus) require specific features from the transmission system serving them:

- It is beneficial that the transmission system offers the possibility to repeatedly turn the power off to some parts of the reception chain. This will reduce the average power consumption of the receiver.
- It is beneficial that the transmission system ensures that it is easy for receivers to move from one transmission cell to another while maintaining the DVB-H service.
- For a number of reception scenarios; indoor, outdoor, pedestrian and inside a moving vehicle, it is beneficial that the transmission system offers sufficient flexibility and scalability to allow the reception of DVB-H services at various speeds, whilst optimizing transmitter coverage.
- As services are expected to be delivered in environments that suffer high levels of man-made noise, it is beneficial that the transmission system offers the means to mitigate their effects on the performance of the receiving terminal.

- As DVB-H aims to provide a generic way to serve handheld terminals in various part of the world, it is beneficial that the transmission system offers the flexibility to be used in various transmission bands and channel bandwidths.

A full DVB-H system is a combination of elements of the physical and link layers, as well as service information. DVB-H makes use of the following technological elements for the link and physical layers:

- Link layer:
 - Time slicing in order to reduce the average power consumption of the receiving terminal and enable smooth and seamless frequency handover. Time slicing is mandatory for DVB-H.
 - Forward error correction for multiprotocol encapsulated data (MPE-FEC) for an improvement in C/N-performance and Doppler performance in mobile channels, also to improve the tolerance to impulse interference. MPE-FEC is not mandatory for DVB-H.

- Physical layer:

DVB-T [i.1] with the following technical elements specifically targeting DVB-H use:

- DVB-H signalling in the TPS-bits to enhance and speed up service discovery. A cell identifier is also carried in the TPS-bits to support quicker signal scan and frequency handover on mobile receivers. DVB-H signalling is mandatory for DVB-H.
- 4K-mode for trading off mobility and SFN cell size, allowing single antenna reception in medium SFNs at very high speed, adding flexibility for the network design. 4K mode is not mandatory for DVB-H.
- In-depth symbol interleaver for the 2K and 4K-modes to further improve the robustness in mobile environments and impulse noise conditions. In-depth symbol interleavers for 2K and 4K are not mandatory for DVB-H.

NOTE: As stated in the standard, to provide DVB-H services; time slicing, cell identifier and DVB-H signalling are mandatory; all other technical elements may be combined arbitrarily.

It should be mentioned that both time slicing and MPE-FEC technology elements, as they are implemented on the link layer, do not affect the DVB-T physical layer in any way. It is also important to notice that the payload of DVB-H is IP-datagrams or other network layer datagrams encapsulated into MPE-sections.

The conceptual structure of a DVB-H receiver is depicted in figure 4.1. It includes a DVB-H demodulator and a DVB-H terminal. The DVB-H demodulator includes a DVB-T demodulator (with optional 4K mode), a time slicing module and an optional MPE-FEC module:

- The DVB-T demodulator recovers the MPEG-2 Transport Stream packets from the received DVB-T [i.1] RF signal. It offers three transmission modes; 8K, 4K and 2K with the corresponding Transmitter Parameter Signalling (TPS). Note that the 4K mode, the in-depth interleavers and the TPS DVB-H signalling have been defined in the context of the DVB-H standard.
- The time slicing module, provided by DVB-H, aims to reduce receiver power consumption while also enabling a smooth and seamless frequency handover.
- The MPE-FEC module, provided by DVB-H, offers in addition to the physical layer transmission, a complementary forward error correction function that allows the receiver to cope with particularly difficult reception situations.

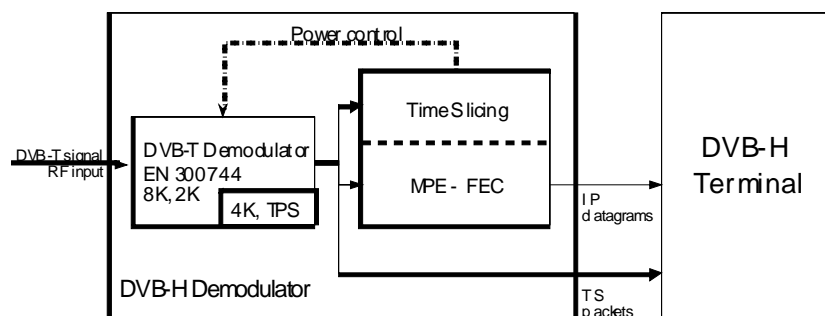

Figure 4.1: Conceptual structure of a DVB-H receiver

An example of using DVB-H for transmission of IP-services is given in figure 4.2. In this example, both traditional MPEG-2 services and time-sliced "DVB-H services" are carried over the same multiplex. The handheld terminal decodes/uses IP-services only. Note that 4K mode and the in-depth interleavers are not available in cases where the multiplex is shared between services intended for fixed DVB-T receivers and services for DVB-H devices.

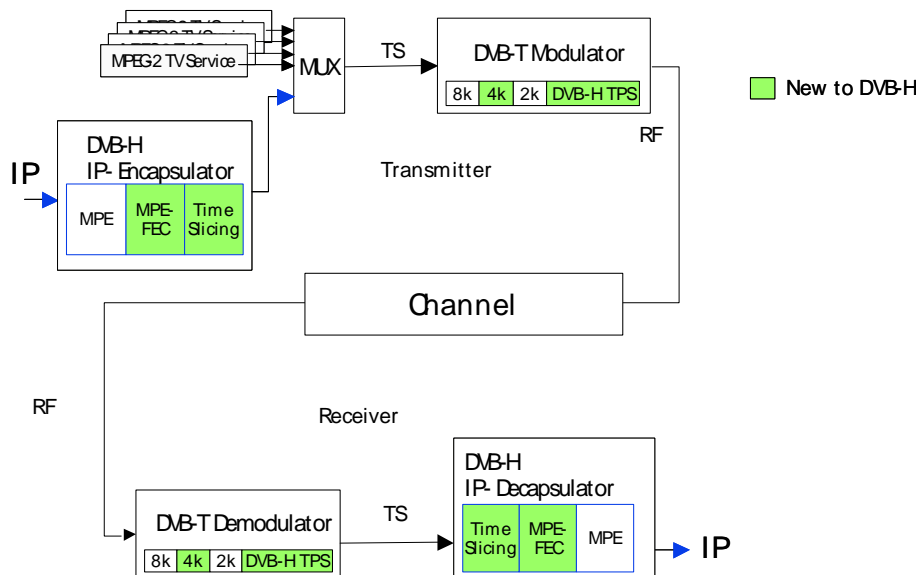

Figure 4.2: A conceptual description of using a DVB-H system (sharing a MUX with MPEG-2 services)

4.2 Time slicing

The objective of time slicing is to reduce the average power consumption of the terminal and enable smooth and seamless service handover. Time slicing consists of sending data in bursts using a significantly higher instantaneous bitrate compared to the bitrate required if the data were transmitted using traditional streaming mechanisms.

To indicate to the receiver when to expect the next burst, the time (Δt) to the beginning of the next burst is indicated within the burst currently being received. Between the bursts, data of the elementary stream is not transmitted, allowing other elementary streams to share the capacity otherwise allocated. Time slicing enables a receiver to stay active for only a fraction of the time, i.e. when receiving bursts of a requested service. Note that the transmitter is constantly on (i.e. the transmission of the transport stream is never interrupted).

Time slicing also supports the possibility to use the receiver to monitor neighbouring cells during the off-times (between bursts). By accomplishing the switching of the reception from one transport stream to another during an off period it is possible to accomplish a quasi-optimum handover decision as well as seamless service handover.

A more detailed discussion about the time slicing parameters is given in clause 9.1.3.2.4 and in annex C. Typical burst cycle time would be in the range of 1 s to 2 s without compromising the power saving or other performances.

4.3 MPE-FEC

The objective of the MPE-FEC is to improve the C/N and Doppler performance in mobile channels and to improve the tolerance to impulse interference.

This is accomplished through the introduction of an additional level of error correction at the MPE layer. By adding parity information calculated from the datagrams and sending this parity data in separate MPE-FEC sections, error-free datagrams can be output (after MPE-FEC decoding) even under bad reception conditions.

With MPE-FEC, a flexible amount of the transmission capacity is allocated to parity overhead. For a given set of transmission parameters providing 25 % of parity overhead, the receiver with MPE-FEC may require about the same C/N as a receiver with antenna diversity and without MPE-FEC.

The MPE-FEC overhead can be fully compensated by choosing a slightly weaker transmission code rate, while still providing far better performance than DVB-T (without MPE-FEC) for the same throughput. This MPE-FEC scheme should allow high-speed single antenna DVB-T reception using 8K/16-QAM or even 8K/64-QAM signals. In addition MPE-FEC provides good immunity to impulse noise interference.

The MPE-FEC, as standardized, works in such a way that MPE-FEC ignorant (but MPE capable) receivers will be able to receive the data stream in a fully backwards-compatible way, provided it does not reject the stream_type information.

4.4 Additional 4K mode and in-depth interleavers

The objective of the 4K mode is to improve the network planning flexibility by trading off mobility and SFN size. To further improve robustness of the DVB-T 2K and 4K modes in a mobile environment and impulse noise reception conditions, an in-depth symbol interleaver is also standardized.

The additional 4K transmission mode is an intermediate mode between the 2K and 8K. It aims to offer an additional trade-off between single frequency network (SFN) cell size and mobile reception performance, providing an additional degree of flexibility for network planning.

Terms of the trade-off can be expressed as follows:

- The DVB-T 8K mode can be used both for single transmitter operation and for small, medium and large SFNs. It provides a Doppler tolerance allowing high speed reception.
- The DVB-T 4K mode can be used both for single transmitter operation and for small and medium SFNs. It provides a Doppler tolerance allowing very high speed reception.
- The DVB-T 2K mode is suitable for single transmitter operation and for small SFNs with limited transmitter distances. It provides a Doppler tolerance allowing extremely high speed reception.

For 2K and 4K modes the in-depth interleavers increase the flexibility of the symbol interleaving, by decoupling the choice of the inner interleaver from the transmission mode used. This flexibility allows a 2K or 4K signal to benefit from the memory of the 8K symbol interleaver. This effectively quadruples (for 2K) or doubles (for 4K) the symbol interleaver depth to improve reception in fading channels. This also provides an extra level of protection against short noise impulses caused for example by automobile ignition interference or domestic electrical appliances.

4K and in-depth interleavers affect the physical layer, however their implementations do not imply large increase in equipment (i.e. logic gates and memory) over the DVB-T standard EN 300 744 [i.1] for either transmitters or receivers. A typical mobile receiver already incorporates enough RAM and logic for the management of 8K signals, which already exceed that required for 4K operation.

The emitted spectrum of the 4K mode is similar to the 2K and 8K modes and thus no changes to the transmitter filters are envisaged.

4.5 DVB-H Signalling

The objective of the DVB-H signalling is to provide a robust and easy-to-access signalling to the DVB-H receivers, thus enhancing and speeding up service discovery.

TPS is a very robust signalling channel allowing TPS-lock in a demodulator with very low C/N-values. TPS also provides a faster way to access signalling than demodulating and decoding the Service Information (SI) or the MPE-section header.

The DVB-H system uses two TPS bits to indicate the presence of time slicing and optional MPE-FEC. Besides these, the signalling of the 4K mode and the use of in-depth symbol interleavers are also standardized.

5 Link layer elements: time slicing and MPE-FEC

5.1 Description of the main issues

5.1.1 Power consumption

The DVB Project estimated the future power consumption of DVB-T implementations. The estimation for a mobile handheld terminal was that the power consumption of the RF and baseband processing may come down to 600 mW by the year of 2007. However, the average power consumption of any additional receiver in a mobile handheld terminal should be less than 100 mW. This is required due both to the limited battery capacity and to the extremely challenging heat dissipation in a miniaturized environment. In the future, when merging an estimated, state-of-art-technology such as a DVB-H Receiver into a mobile handheld terminal, the required reduction in power consumption may become as high as 90 %.

5.1.2 Handover

For mobile reception in a DVB-T MFN network, there is normally the need to handover to another frequency when the reception quality of the present frequency becomes too low. Since DVB-T does not include seamless handover facilities, changing frequency normally results in a service interruption. In addition to this the Receiver will have to scan possible alternative frequencies to find out which of these provides the best or at least sufficient reception quality. Each time a frequency is scanned there will be an interruption, unless the Receiver is equipped with an extra RF part dedicated for this purpose. The inclusion of such an extra RF part would increase the cost of Receivers.

There is therefore a requirement to allow for seamless handover and seamless scanning of alternative frequencies without having to include an additional RF part.

5.1.3 RF performance for mobile single antenna reception

The required Carrier-to-Noise ratio (C/N) for reception of DVB-T signals is a very important parameter, which highly affects network costs in general and in particular the possibilities to receive services carried over DVB-T with a good QoS at high reception speeds. Techniques like antenna diversity reception improve performance significantly, but are not practically suited for small handheld devices, where single antenna reception and low power consumption are required. From a spectrum efficiency, network cost, and coverage point of view Single Frequency Networks (SFNs) are highly desirable. Such networks normally require the use of the 8K mode of DVB-T. However, mobile single antenna reception at high speeds using the 8K mode is very difficult, except for the most rugged modes.

There is therefore a requirement for lower network costs in general and for the possibility of using higher bitrates for mobile DVB-T reception.

There are also requirements for better immunity against impulsive interference, which appear in receiving conditions where handheld receivers are used.

5.2 How time slicing and MPE-FEC provide a solution

5.2.1 Power consumption

Services used in mobile handheld terminals require relatively low bitrates. The estimated maximum bitrate for streaming video using advanced compression technology like MPEG-4 is in the order of a few hundred Kilobits per second (Kb/s), one practical limit being 384 Kb/s coming from the 3G standard. Some other types of services, such as file downloading, may require significantly higher bitrates, though. Therefore there is a requirement for flexibility.

A DVB transmission system usually provides a bitrate of 10 Mb/s or more. This provides a possibility to significantly reduce the average power consumption of a DVB receiver by introducing a scheme based on Time Division Multiplexing (TDM). This scheme is called time slicing.

The concept of time slicing is to send data in bursts using a significantly higher bitrate compared to the bitrate required if the data was transmitted continuously. Within a burst, the time to the beginning of the next burst (Δt) is indicated. Between the bursts, the data of the elementary stream is not transmitted, allowing other elementary streams to use the bitrate otherwise allocated. This enables a Receiver to stay active for only a fraction of the time, while receiving bursts of a requested service. If a constant lower bitrate is required by the mobile handheld terminal, this may be provided by buffering the received bursts.

To get a reasonable power saving effect, the Burst Bitrate should be at least 10 times the Constant bitrate of the delivered service. In case of a 350 Kb/s streaming services, this indicates a requirement of 4 Mb/s bitrate for the bursts. Note that if the Burst bitrate is only twice the Constant bitrate, this gives near to 50 % power saving - which is still far from the required 90 % mentioned in clause 5.1.1.

Power consumption estimations

The power consumption depends on the duty cycle of the time slicing scheme. We assume here a 10 % duty cycle, which implies a 90 % reduction in power consumption. The power consumption estimations took into account the duty cycle as well as the increase in power consumption due to the MPE-FEC. The results estimated about 2 mW additional power consumption with 0,13 μm technology, and about 1 mW using 0,18 μm technology for the MPE-FEC.

It should be pointed out that these power consumption estimations assume that *all* RS codewords are *always* decoded. However, for most of the time in normal receiving conditions (particularly low speed reception) the RS decoding will not be used, because the MPEG-2 TS is already fully correct and so no MPE-FEC decoding will be necessary. Even in situations when the MPE-FEC is used it may be used only for a subset of the received bursts. This leads to the conclusion that for a mixture of receiving conditions (probably typical to real user behaviour) the MPE-FEC will consume the additional 2 mW estimated only occasionally. The effect on battery time will therefore be negligible.

5.2.2 Handover

Time slicing supports the possibility of using the Receiver to monitor neighbouring cells during the Off-times. By accomplishing the switching between transport streams during an off period, the reception of a service is seemingly uninterrupted.

With proper care, and outside the scope of the present document, the bursts of a certain IP stream can be synchronized between neighbouring cells in a way that the Receiver can tune to the neighbouring cell and continue receiving the IP stream without losing any data.

Please notice that in a SFN, handover is only required when the terminal changes network, since all transmitters in the SFN form a single cell.

5.2.3 RF performance for mobile single antenna reception

The MPE-FEC is defined on the MPE layer, i.e. independent of the DVB-T physical layer. With the addition of FEC parity data in new sections, parallel to MPE sections carrying IP datagrams, it is possible to recreate error-free IP datagrams despite a very high Packet Loss Ratio (PLR) on the MPE level. Such high PLR may sometimes occur with DVB-T on mobile channels when the speed is too high and/or the C/N is too low. Performance estimations show that the proposed MPE-FEC should be able to output an error-free IP stream down to a PLR of about 10 %. With the MPE-FEC about 25 % of TS data is allocated to parity overhead. For a given set of DVB-T parameters the MPE-FEC may require about the same C/N as if antenna diversity was used or if inner time interleaving was to be introduced in DVB-T, although with a 25 % lower throughput, due to the parity overhead. This can however be compensated for by choosing a slightly weaker code rate in DVB-T. For example with 16-QAM, code rate 2/3 and MPE-FEC the same throughput can be provided as with 16-QAM and code rate 1/2, but with a much better performance. This should allow high-speed, single antenna DVB-T reception using 8K/16-QAM or even 8K/64-QAM signals.

The MPE-FEC also provides good immunity to impulsive interference. With MPE-FEC, reception is fully immune to repetitive impulsive noise causing a destruction of the OFDM symbols if the distance between the destroyed symbols is in the range 6 ms to 24 ms. This depends on the chosen DVB-T mode.

The proposed additional MPE-FEC is introduced in such a way that MPE-FEC ignorant (but IP/MPE capable) DVB-T receivers will be able to receive the IP stream in a fully backwards-compatible way. This backwards compatibility holds when the MPE-FEC is used with and without time slicing.

The use of MPE-FEC is not mandatory and is defined separately for each elementary stream in the Transport Stream. On each elementary stream it is possible to choose whether or not MPE-FEC is used in the first place, and if it is used, to choose the trade-off between FEC overhead and RF performance. Time critical services, without MPE-FEC and therefore minimal delay, could therefore be used together with less time critical services using the MPE-FEC, on the same Transport Stream but on different elementary streams.

5.2.4 Time slicing and MPE-FEC used together

When time slicing and MPE-FEC are used together, one Time Slice burst carries exactly one MPE-FEC frame. The first part of the burst is the MPE sections carrying the IP datagrams belonging to the MPE-FEC frame. Immediately following the last MPE section is the first MPE-FEC section carrying the parity bytes. All sections contain a `table_boundary` flag, this is set high in the last MPE section to indicate this is the last MPE section of the MPE-FEC frame. If all the MPE sections within the burst have been received correctly the receiver can then neglect the MPE-FEC sections and go to sleep until the next burst. All sections contain a `frame_boundary` flag, this is set high in the last MPE-FEC section to indicate that this is the last MPE-FEC section and hence the end of the MPE-FEC frame.

5.3 Time slicing implementation

Time slicing aims to reduce the power consumption in handheld mobile terminals. Therefore it is obvious that the optimization of time slicing is done from a terminal point of view. This selection also follows the DVB adopted rule of optimizing implementations on receivers, as their number is far higher than the number of transmitters. Also the implementation cost on the network side is typically less critical compared to the terminal side.

5.3.1 Receiver

For terminological reasons, an entity called a Receiver is introduced. This entity is assumed to support some of the functionality on a traditional IRD, including especially RF, channel decoding and demultiplexing. The Receiver supports access to services delivered via DVB transmission to a mobile handheld terminal.

Time slicing enables the Receiver part to be periodically switched off, through which power saving may be achieved.

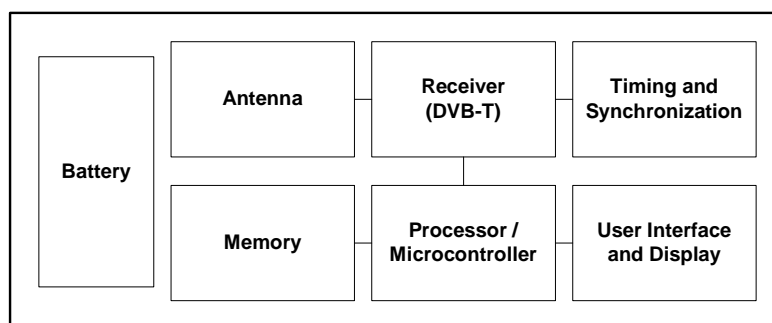

Figure 5.1: Handheld Mobile Terminal

5.3.2 Protocol stack

Decoding high bandwidth MPEG-2 encoded streaming video/audio is relatively power consuming. Therefore it cannot be considered as an option for a handheld mobile convergence terminal. At the same time, there are a number of reasons why time slicing is not well suited for services requiring high bitrate, one being that a reasonable length for the Off-time is not feasible (the bitrate required by a service is too high compared to the bitrate supported by a transmission path).

Using Internet Protocol allows the coding to be decoupled from the transport, thus opening the door to a number of features benefiting handheld mobile terminals including a variety of encoding methods, which only require low power from a decoder. Therefore IP is the OSI-layer 3 protocol used in the mobile handheld convergence terminals. In addition, IP is relatively insensitive to any buffering or delays within the transmission (unlike MPEG-2). Therefore IP is well suited for handheld mobile terminals. IP is also well suited for Time-sliced transmission.

IPv6 may be better suited in mobile environments (compared to IPv4). Therefore IPv6 may be the preferred option on the broadcast interface. However, both time slicing and MPE-FEC may be used with both IPv4 and IPv6. Therefore - when referring to time slicing and/or MPE-FEC - no distinction is made regarding the version of IP. Later in the present document a reference to IP indicates that both IPv6 and IPv4 apply.

DVB has specified four methods for data broadcasting; Data Piping, Data Streaming, Multi-Protocol Encapsulation (MPE) and Data Carousel. They can all be used for delivering IP. Data Piping and Data Streaming are used so rarely that they are ignored in this context. Data Carousels support delivery of files and other data objects, but are not suited for streaming services. Also, implementing time slicing on Data Carousels may be difficult. MPE is well suited to the delivery of streaming services as well as files and other data objects. Note that DVB has specified IP address resolution on MPE - that is, INT table. In addition, MPE supports delivery of other protocols, giving more flexibility. Finally, implementing time slicing on MPE is simple.

Figure 5.2 illustrates the expected protocol stack for delivering IP data on DVB transmission.

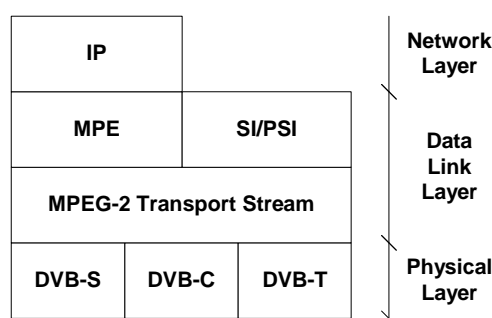

Figure 5.2: Protocol stack, OSI-layers 1 to 3

5.3.3 Implementation in the Link layer

Within the Link Layer (OSI-layer 2), time slicing could in principle be implemented either on MPE level (delta-t delivered within MPE section) or on Transport Stream level (delta-t delivered within transport_packet).

To enable MPE-FEC as introduced in clause 5.4, time slicing has to be implemented on MPE level due to the following reasons:

- Simple and cost efficient implementation on receiver side. Can be implemented using existing hardware, since the handling of real time parameters could be implemented in software. Depending on implementations, time slicing could be adopted even in existing IRDs by updating only the system software.
- Simple and cost efficient implementation on network side. All required functionality can be implemented within the IP Encapsulator.
- Delivering real time parameters has no effect on the bitrate. Parameters can be delivered within the MAC_address field.
- Backward compatible. The current MPE specification specifies a method to allocate a part of the MAC_address field for other uses. The minimum length of the MAC address is one byte, allowing up to five bytes to be used for real time parameters. In the case of time slicing, the filtering function may use the MAC address and/or the IP address.

5.3.4 Delta-t method

The basic goal of the **delta-t** method is to signal the time from the start of the MPE (or MPE-FEC) section, currently being received, to the start of the next burst within the elementary stream. To keep the delta-t insensitive to any constant delays within the transmission path, delta-t timing information is relative (e.g. "next burst within this elementary stream will start 5 500 ms from the present time"). The standard also defines that delta-t equal to zero means "End of Service". No bursts related to the service are sent any more.

Delivering delta-t in MPE (or MPE-FEC) sections removes the need to synchronize clocks between transmitter and Receiver. This is highly flexible since parameters such as Burst Size, Burst Duration, Burst Bitrate and Off-time may vary between elementary streams as well as between bursts within an elementary stream. The Receiver has to be sufficiently accurate for one Off-time only because the clock is restarted by each burst.

The resolution of delta-t signalling is 10 ms. Due to this and jitter (which is discussed below), it is not possible to signal the exact starting time of the next burst. Instead, the delta-t actually signals the earliest possible time when the next burst may start. This also means that the signalled delta-t value is produced by rounding the intended value down to the nearest multiple of 10ms (e.g. 107 ms is signalled as 100 ms).

Within the MPE section header, a 6-byte field is allocated for the MAC address. The length of the MAC address is signalled in the data_broadcast_descriptor inserted in the SDT or EIT. The minimum MAC address length is one byte, leaving up to five bytes for other use. It is suggested in the present document that four of these five bytes are allocated for delivering time slicing and MPE-FEC parameters in real-time. This gives an additional benefit, as no additional bitrate is required for delivering these parameters. Note that transmitting the five bytes is mandatory regardless whether they are used for MAC address or not.

In case of multicast IP streams the MAC address is actually redundant data, as the MAC address is a function of the multicast group IP address. For all IP streams, the IP datagram header following immediately after the MPE section header includes source and destination IP addresses uniquely identifying the IP stream. The Receiver can either ignore the MAC address entirely, filtering IP addresses only, or use the one byte MAC address to differentiate the IP streams within the elementary stream. Even if hardware filtering within the demux is implemented on the section level only, the IP layer would be able to filter any unused IP datagrams based on the IP addresses.

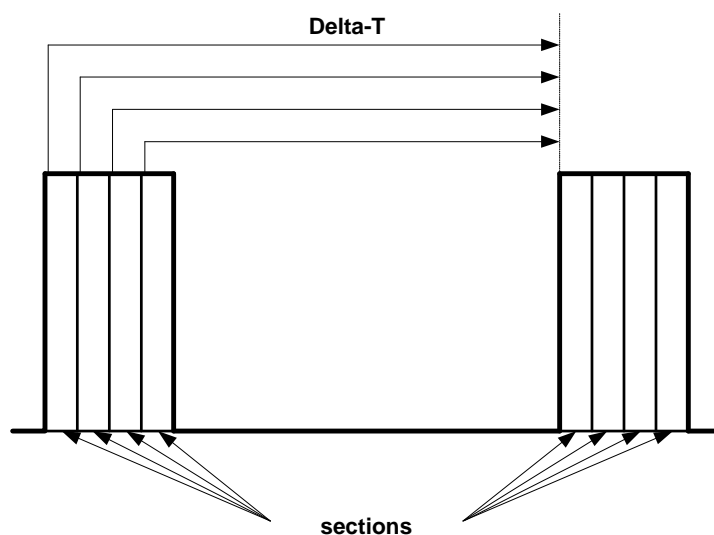

Figure 5.3: Each MPE section header contains delta-t indicating time to the beginning of the next burst

In bad reception conditions, parts of a burst may be lost. In case the delta-t information is lost, the Receiver would not know the time to the next burst and therefore is forced to stay on waiting for the next burst. To avoid this situation, delta-t (together with other real time parameters) is delivered in the header of each MPE section and MPE-FEC section within a burst. Even in very bad reception conditions, if only one MPE section or MPE-FEC section is received, proper delta-t information can be accessed and power saving achieved.

As delta-t indicates the relative time rather than absolute one, the method is insensitive to any constant delays within the transmission path. However, jitter does have an effect on the accuracy of delta-t. This jitter is later referred as **Delta-t Jitter**. If delta-t indicates the earliest possible time when the next burst may start, any Delta-t Jitter can be handled by decreasing the delta-t - and therefore decreasing the accuracy of the delta-t. Note however that the accuracy of delta-t has an effect on the achieved power saving. It is possible to perform a jitter estimation in the receiver, in order to ensure that the wakeup time for the next burst is not mistakenly too late because of the current burst being delayed.

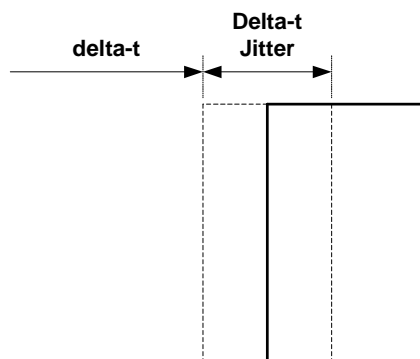

Figure 5.4: Delta-t Jitter

For time slicing, Delta-t Jitter of 10 ms can be accepted, the reason being that 10 ms is the resolution of the delta-t signalling. This should be easily achieved because typical transmission paths already support far better accuracy. On the other hand, virtually no gain is achieved by decreasing the value below 10 ms, as it is already less than a typical jitter in **Synchronization Time**.

Synchronization Time is the extra time required by a Receiver to re-acquire lock onto the signal before the start of the reception of the next burst. In current DVB-T implementations the time is estimated to be at most in the order of 200 ms to 250 ms. Synchronization Time is implementation dependent, and typically differs noticeably from time to time (i.e. has noticeable jitter).

One can see how Delta-t Jitter has a similar effect as Synchronization Time. When the maximum Delta-t Jitter is known accurately, we may assume that on average each burst starts $1/2 \times \text{Delta-t Jitter}$ later than the time indicated by delta-t. However, to be on the safe side, calculations later in the present document add $3/4 \times \text{Delta-t Jitter}$ to the Synchronization Time. This allows a network operator to use twice the accurate value of the Delta-t Jitter.

5.3.5 Burst Size and Off-time

The size of a burst has to be less than the memory available in a Receiver. When a burst is received, a Receiver has to buffer the data within its memory, to be consumed during the time between bursts. We may assume that a Receiver can support 2 Mb memory for buffering an incoming burst. Streaming services may require even bigger buffering, even if time slicing is not used. Note that a Receiver supporting reception of multiple Time-sliced elementary streams simultaneously may need to support a 2 Mb buffer for each Time-sliced elementary stream, unless the elementary streams use smaller Burst Sizes.

Burst Size refers to the number of Network Layer bits within a burst. Network Layer bits consist of section payload bits. Each MPE and MPE-FEC section contains 16 bytes overhead caused by the header and CRC-32. Assuming an average IP datagram size of 1 kB, this indicates a 1,5 % overhead. In addition, the transport_packet header causes overhead, which depends on the length of a section. If the length of a section is 1 kB, the overhead is approximately 2,2 %. The present document assumes a 4 % overhead is caused by section and transport_packet headers.

Burst Bitrate is the bitrate used by a Time-sliced elementary stream while transmitting a burst. **Constant Bitrate** is the average bitrate required by the elementary stream when not Time-sliced. Both Burst and Constant Bitrate include transmission of transport_packets (188 bytes). For a Burst Size of 1 Mb and a Burst Bitrates of 1 Mb/s, the **Burst Duration** (time from the beginning to the end of the burst) is 1,04 s (due to the 4 % overhead).

Off-time is the time between bursts. During Off-time, no transport_packets are delivered on the relevant elementary stream.

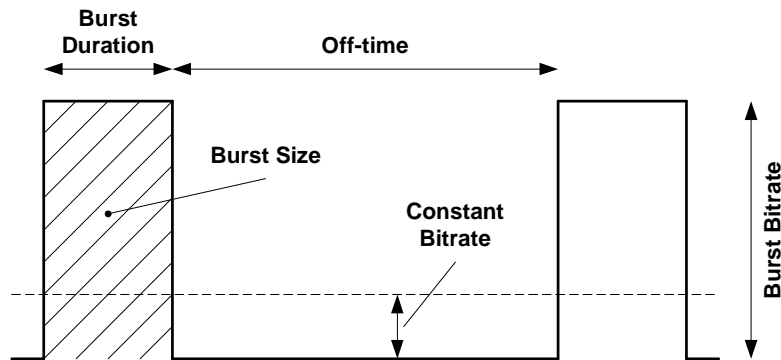

Figure 5.5: Burst parameters

Note that during the On-time (i.e. while a burst is transmitted), transport_packets of other elementary streams may also be transmitted. This occurs when the Burst Bitrate is less than the bitrate of the transport stream (i.e. the burst uses only a part of the bitrate available on the transport stream).

In this case, the transport packets of the Time-sliced and non-Time-sliced elementary streams are multiplexed together on a packet-by-packet basis. This ensures that traditional DVB-T receivers, which receive non-Time-sliced services, are not locked out from reception during a Time-slice burst.

Maximum Burst Duration defines the duration during which a burst occurs, and that is signalled for each Time-sliced elementary stream. A burst cannot start before the latest predicted T1 and it has to end before the earliest predicted T2, where T1 is the time indicated by delta-t on the previous burst, and T2 is the earliest predicted T1+max_burst_duration (see figure 5.6).

As the delta-t (and thus T1) is signalled with the resolution of 10ms, and the Maximum Burst Duration with the resolution of 20 ms, the signalled Maximum Burst Duration should always be at least 30ms larger than the actual duration of the burst. The maximum burst duration should be less than two seconds and less than the cycle time.

To enable a Receiver to reliably distinguish bursts from each other, the next burst cannot start before T2 of the current burst (i.e. it is necessary that delta-t signals time beyond T2). Distinction between bursts in a reliable way is required especially when MPE-FEC is used (for more information on MPE-FEC, see clause 5.4).

Note that this parameter can also be used to support Delta-t Jitter up to a number of seconds.

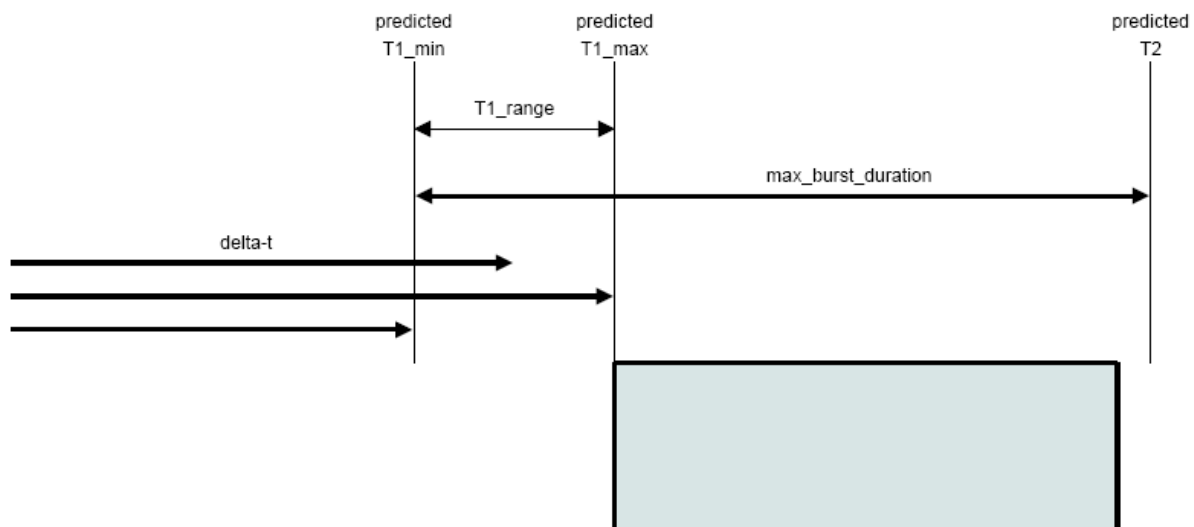

Figure 5.6: Maximum Burst Duration

Figure 5.7 shows some simplified formulas used to calculate the length of a burst, length of the off-time, and achieved power saving. The correction factor 0,96 compensates for the overhead caused by transport_packet and section headers. Note that the formulas are provided for an explanatory purpose only.

Bd	Burst Duration (seconds)	$Bd = \frac{Bs}{Bb \times 0,96}$
Bs	Burst Size (bits)	
Bb	Burst Bitrate (bits per second)	
Cb	Constant Bitrate (bits per second)	$Ot = \frac{Bs}{Cb \times 0,96} - Bd$
Ot	Off-time (seconds)	
St	Synchronization Time (seconds)	
Ps	Power Saving (per cent)	$Ps = \left(1 - \frac{(Bd + St + (3/4 \times Dj)) \times Cb \times 0,96}{Bs} \right) \times 100 \%$
Dj	Delta-t Jitter (seconds)	

Figure 5.7: Formulas to calculate the length of a burst, off-time and the achieved saving on power consumption

If the Burst Size is 2 Mb (over MPE and MPE-FEC section payloads) and the Burst Bitrate is 15 Mb/s (over related transport packets), the maximum Burst Duration is 140 ms (from the beginning of the first transport packet, to the end of the last one). If the elementary stream carries one streaming service at constant bitrate of 350 Kb/s, and MPE-FEC is not supported, the average Off-time is 6,10 s. Assuming a Synchronization Time of 250 ms and a Delta-t Jitter of 10 ms, a 93 % saving on power consumption may be achieved. The Delta-t Jitter has only a small effect on the power saving, as changing the value from 0 ms to 100 ms decreases the achieved power saving only from 94 % to 92 %.

Figure 5.8 shows how the Burst Bitrate increasing up to approximately 10 times the Constant Bitrate increases the achieved Power Saving. For a Constant Bitrate of 350 Kb/s, increasing the Burst Bitrate from 1 Mb/s to 2 Mb/s increases the Power Saving from 60 % to 78 % (i.e. 30 %). However, similar doubling on Burst Bitrate from 7 Mb/s to 14 Mb/s gives less than 3 % benefit on Power Saving (91 % to 93 %).

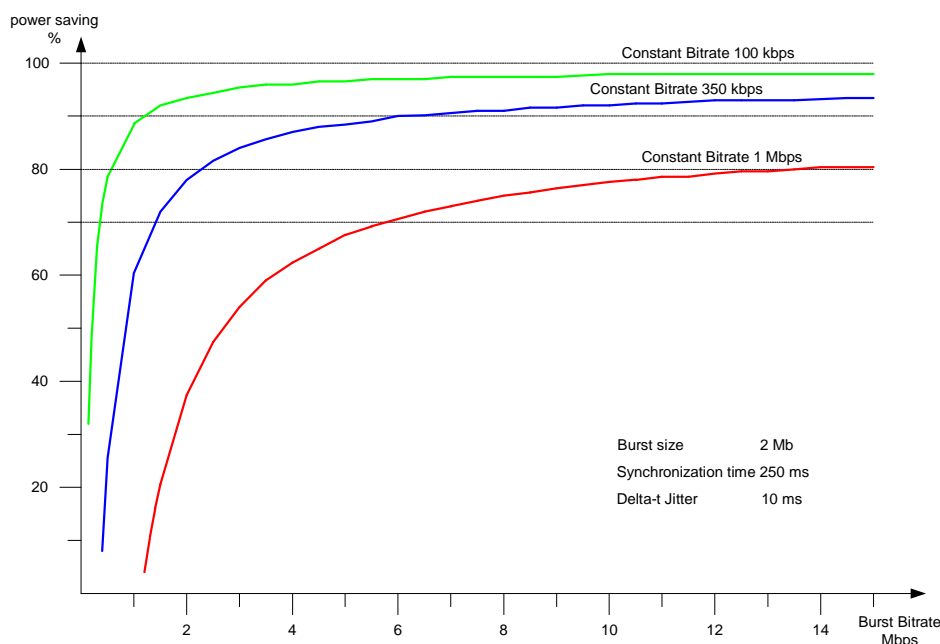

Figure 5.8: Relation between burst bitrate and power saving

5.3.6 Handover support

Time slicing enables a Receiver to monitor neighbouring cells without interrupting service reception. During the time between bursts, the Receiver may scan for other available signals, compare the signal strengths, and even implement a hand-over between transport streams without interrupting the service reception.

Processing such tasks has an effect on total power saving possible, since the Receiver needs to remain powered during the process. However, the effect may be kept at an acceptable level. The required time for checking the signal strength on a single frequency is typically less than 20 ms. Using intelligent methods to anticipate available signals (i.e. neighbouring cells), a Receiver can significantly decrease the number of frequencies to check. Should the checking be accomplished once each cycle, the time required would still be only a fraction of the Off-time.

Careful synchronization may be implemented in the headend, so that the same service is transmitted on different slices at the same time in neighbouring cells. This would ensure seemingly uninterrupted (zero packet loss) reception when handing over from one cell to another. Further consideration of burst synchronization is outside the scope of the present document.

5.3.7 Mixing Time Sliced elementary streams into a multiplex

Figure 5.9 illustrates a simplified construction of a headend for which the transmission is dedicated to IP services only.

The IP Encapsulator is assumed to take responsibility for generating MPE sections from incoming IP datagrams, as well as to add the required PSI/SI data. Also, MPE-FEC Frames, when used, are generated in the IP Encapsulator (for more about MPE-FEC Frames, see clause 5.4.1). The output stream of the IP Encapsulator is composed of MPEG-2 transport packets.

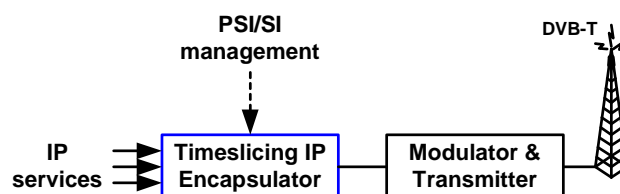

Figure 5.9: Headend construction for dedicated multiplex

As there are no other services (i.e. no non-Time-sliced services), the headend functionality remains simple. Timeslice bursts are generated in the IP Encapsulator. A burst may use the maximum bitrate. Any off period (time when no data bursts on any elementary stream are transmitted) may be filled with null packets. PSI/SI sections may be spread over the transport stream by allocating a constant bitrate for it. Note that fine tuned time slicing never leaves off periods, as there is always a burst of one elementary stream in transmission.

Figure 5.10 illustrates the construction of a headend for the transmitted multiplex containing both IP services and other (digital-TV) services. The major difference to the case of a dedicated multiplex is the requirement for a multiplexer. Note that this is similar to a case where a transport stream containing Time-sliced elementary streams is remultiplexed.

It is assumed that a constant bitrate is allocated for all Time-sliced elementary streams. The rest of the transport stream bitrate is available for non-Time-sliced elementary streams.

The process of multiplexing typically increases Delta-t Jitter. This has a negative effect on the accuracy of delta-t, therefore decreasing the power consumption saving. As noted before, a typical transmission path including multiplexer(s) can guarantee jitter well under the required 10 ms. Therefore, usage of a multiplexer in general does not have a significant effect on time slicing. However, it is important that the increase in Delta-t Jitter is taken into account in delta-t signalling.

Other services may set requirements on how the bitrate is divided between elementary streams. E.g. PCR packets are recommended to appear in the transport stream every 40 ms. Since Burst Bitrate may be less than the full bitrate of the transport stream, this can easily be solved.

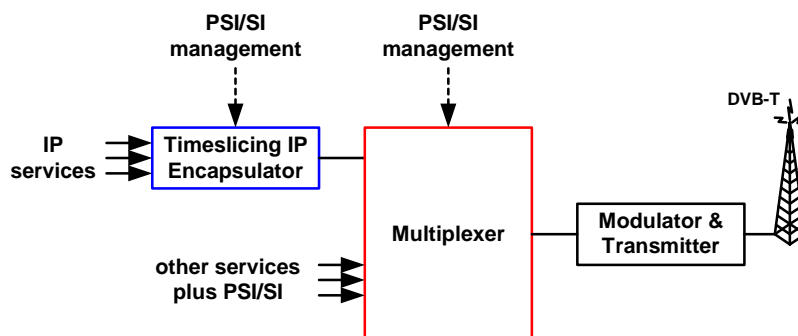

Figure 5.10: Headend construction for mixed multiplex

One possible way to avoid mixing Time-sliced and non-Time-sliced streams into a common multiplex - and to avoid usage of a multiplexer - is to use the hierarchical transmission mode. In this case the multiplex containing Time-sliced services is transmitted on high priority - ensuring better robustness in mobile environment - while the multiplex for non-Time-sliced services is transmitted on low priority - giving higher bitrate for services on fixed reception. This effectively supports two multiplexes on a single transmission. A simplified construction of the headend supporting hierarchical transmission is illustrated on figure 5.11.

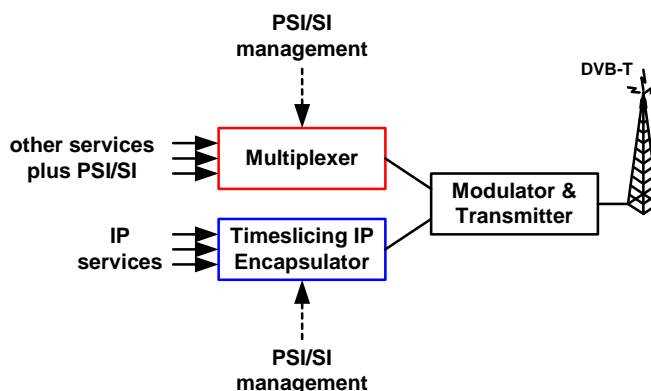

Figure 5.11: Headend construction for hierarchical transmission

5.3.8 Time slicing of PSI/SI

PSI/SI is not Time-sliced. Existing PSI/SI does not support delivery of the delta-t parameter within the tables, and adding such support would not be compatible with existing implementations. In addition, a mobile handheld terminal does not require PSI/SI to be Time-sliced.

The SI tables accessed by a mobile handheld convergence terminal are NIT and INT. Other tables are typically not required, as they carry no additional information for a terminal accessing services delivered via MPE. The content of NIT is static by nature, so a terminal typically only accesses it when attaching to a network. When changing from one transport stream to another, a terminal may need to read the content of INT, but not more than once. Changes in INT can be signalled in PSI (PMT table), ensuring that constant filtering of INT is not required.

The PSI tables are re-transmitted at least once in every 100 ms. When the Burst Duration is longer than 100 ms, the terminal has access to all the PSI tables while receiving the burst. In case of shorter bursts, the terminal may choose to keep the Receiver powered until all required PSI tables are received.

5.4 MPE-FEC implementation

5.4.1 MPE-FEC frame

5.4.1.1 Definition of MPE-FEC frame

The MPE-FEC frame is arranged as a matrix with 255 columns and a flexible number of rows (see figure 5.12). The number of rows may vary from 1 to a value signalled in the *time_slice_fec_identifier_descriptor*. The maximum allowed value for this size is 1 024, which makes the total MPE-FEC frame almost 2 Mb large. Each position in the matrix holds an information byte. The left part of the MPE-FEC frame, consisting of the 191 leftmost columns, are dedicated for IP datagrams and possible padding, and is called the *Application data table*. The right part of the MPE-FEC frame, consisting of the 64 rightmost columns, are dedicated for the parity information of the FEC code and is called the *RS data table*. Each byte position in the Application data table has an address ranging from 1 to $191 \times \text{no_of_rows}$. In the same way, each byte position in the RS data table has an address ranging from 1 to $64 \times \text{no_of_rows}$. Addressing in RS table is redundant, since *section_length* and *section_number* are known.

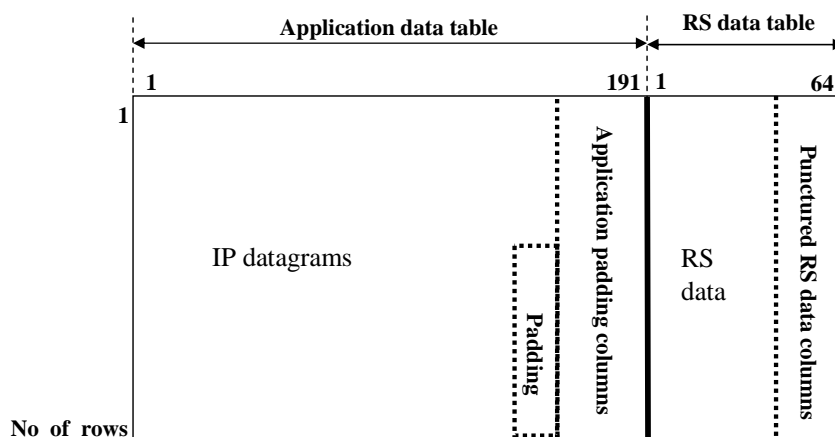

Figure 5.12: The structure of the MPE-FEC frame

5.4.1.2 Application data table

IP datagrams are transmitted datagram-by-datagram, starting with the first byte of the first datagram in the upper left corner of the matrix and going downwards the first column, see figure 5.13. The length of the IP datagrams may vary arbitrarily from datagram to datagram. Immediately after the end of one IP datagram the following IP datagram starts. If an IP datagram does not end precisely at the end of a column, it continues at the top of the following column. When all IP datagrams have entered the Application data table any unfilled byte positions are padded with zero bytes, which makes the leftmost 191 columns completely filled. The number of full padding columns is signalled dynamically in the MPE-FEC section with 8 bits.

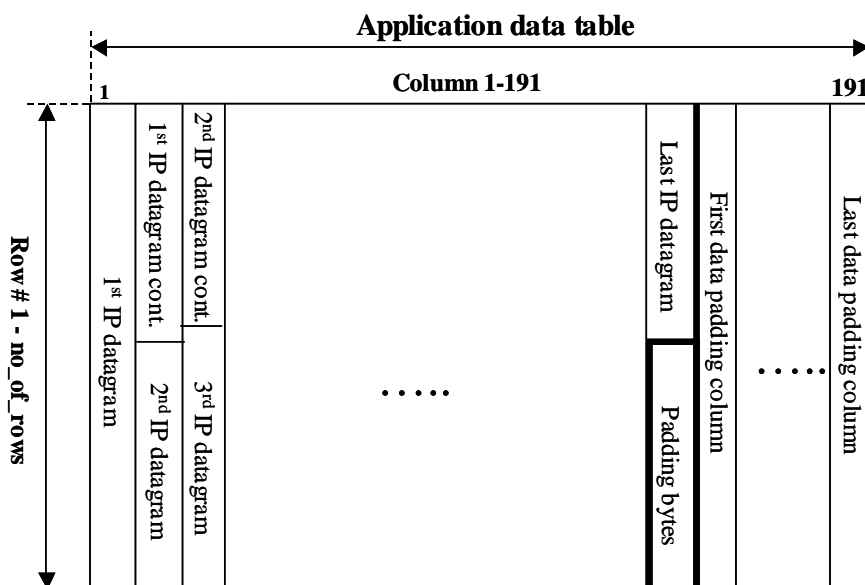

Figure 5.13: The layout of the application data table

5.4.1.3 RS data table

With all the leftmost 191 columns filled it is now possible, for each row, to calculate the 64 parity bytes from the 191 bytes of IP data and possible padding. The code used is Reed-Solomon RS (255, 191) with a field generator polynomial and a code generator polynomial as defined below. Each row then contains one RS codeword. Some of the rightmost columns of the RS data table may be discarded and hence not transmitted, to enable puncturing (see figure 5.14). The exact amount of punctured RS columns does not need to be explicitly signalled and may change dynamically between frames. With this also the RS data table is completely filled and the MPE-FEC frame is completed, see figure 5.14.

Code Generator Polynomial: $g(x) = (x+\lambda^0)(x+\lambda^1)(x+\lambda^2)...(x+\lambda^{63})$, where $\lambda = 02_{\text{HEX}}$

Field Generator Polynomial: $p(x) = x^8 + x^4 + x^3 + x^2 + 1$

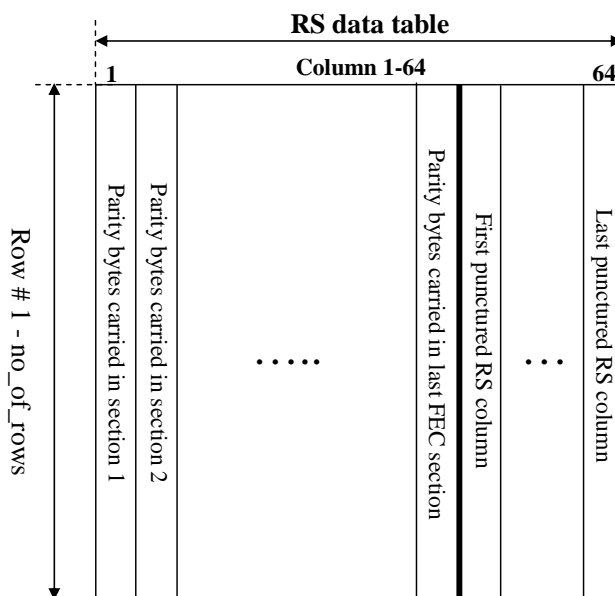

Figure 5.14: The layout of the RS data table

5.4.2 Carriage of MPE-FEC frame

5.4.2.1 Carriage of Application data table datagrams

The IP data is carried in MPE sections in the standard DVB way, irrespective of MPE-FEC being used or not. This makes reception fully backwards compatible with MPE-FEC ignorant receivers. Each section carries a start address for the IP datagram, which is carried within the section. This address indicates the byte position in the Application data table of the first byte of the IP datagram and is signalled in the MPE header. The receiver will then be able to put the received IP datagram in the right byte positions in the Application data table and mark these positions as "reliable" for the RS decoder, provided the CRC-32 shows that the section is correct.

The last section of the Application data table contains a table_boundary flag, which indicates the end of the IP datagrams within the Application data table. If all previous sections within the Application data table have been received correctly the receiver does not need to receive any MPE-FEC sections and, if time slicing is used, can go to sleep without receiving and decoding RS data.

If MPE-FEC sections are received, the exact number of padding columns in the Application data table is indicated with 8 bits in the section header of the MPE-FEC sections - it is only if RS decoding is performed that this value is needed.

5.4.2.2 Carriage of parity bytes in RS data table

The parity bytes are carried in a separate, specially defined section type, with its own table_id. These are similar to MPE sections and are named MPE-FEC sections. The length of an MPE-FEC section is adjusted so that there is exactly one section per column. Punctured columns are not transmitted and not signalled explicitly.

5.4.3 RS decoding

5.4.3.1 Basic functionality

The number of rows is signalled in the time_slice_and_fec_identifier_descriptor but can also be determined from the section_length of the MPE-FEC sections, since the payload length of these sections is equal to the number of rows. In this way there is always exactly one section per column. The number of punctured RS columns can be calculated as $64 - \text{last_section_number}$, since last_section_number indicates the number of sections and therefore number of columns.

The receiver introduces the number of Application data padding columns with zero bytes, which is indicated dynamically by the MPE-FEC sections, and marks these as reliable. If the receiver has received the table_boundary flag correctly it can also add any remaining padding bytes and mark these as reliable. Otherwise, these will have to be treated as unreliable in the same way as other lost data. The receiver also introduces the number of punctured RS columns as calculated from last_section_number. The actual data in the punctured RS columns are irrelevant, as all punctured data is considered unreliable.

All MPE and MPE-FEC sections are protected by a CRC-32 code, which reliably detects all erroneous sections. For every correctly received section belonging to the Application data table or to the RS data table, the receiver looks in the section header for the start address of the payload within the section and is then able to put the payload in the right position the respective table. Note that MPE sections may use either checksum or CRC-32, although is recommended the use of CRC-32. However, when MPE-FEC is used it is mandatory the use of CRC-32. In practice all terminals need to have support for both, checksum and CRC-32.

After this procedure there can be a number of lost sections. All correctly received bytes, and Application data padding, can then be marked as "reliable" and all byte positions in the lost sections, and in the punctured RS columns, can be marked as "unreliable" in the RS decoding.

All byte positions within the MPE-FEC frame (Application data table + RS data table) are now marked as either "reliable" or "unreliable". With such reliability (erasure) information the RS decoder is able to correct up to 64 such bytes per 255-byte codeword.

If there are more than 64 unreliable byte positions in a row, the RS decoder will *not* be able to correct anything and will therefore typically just output the byte errors without error correction. The receiver will therefore have perfect knowledge about the positions of any remaining byte errors within the MPE-FEC frame after RS decoding. If an IP datagram is only partly corrected the receiver will be able to detect this and (optionally) discard this datagram.

In addition to the CRC-32, which detects erroneous sections, the DVB-T RS decoder also very reliably detects erroneous TS packets. If the MPEG-2 demultiplexer discards erroneous packets it could be designed not to build sections, which contain lost TS packets. In this way only correct sections would be built and the role of the CRC-32 would be to provide *additional* error detection functionality, which normally is not needed. In very rare cases it could happen that the DVB-T RS decoder fails to detect an erroneous TS packet, which also happens to have the right PID, and that an erroneous section therefore could be constructed. In these cases the CRC-32 would discover such a section error.

5.4.3.2 Application data padding columns - Code shortening

By introducing a certain number of zero-valued Application data padding columns in the rightmost part of the Application data table, it is possible to make the code *stronger*. These padding columns are only used for the calculation of parity bytes, they are not transmitted. In the receiver they are reintroduced and marked as "reliable" for the RS decoder. With e.g. 127 padding columns, there are 64 columns left for IP data. With the 64 parity columns the effective code rate of the code becomes 1/2. However, the price for this is that the effective codeword length is decreased by roughly 50 %. The number of Application data padding columns is dynamic and signalled in the MPE-FEC sections. The allowed range is 0 to 190.

5.4.3.3 Discarding RS data columns - Puncturing

An effectively *weaker* code than the mother code may be achieved by *puncturing*. Puncturing is performed by discarding one or more of the last RS data columns. The number of discarded (punctured) RS columns may vary dynamically between MPE-FEC Frames within the range 0 to 63 and can be calculated as 63 - last_section_number, except for the case when no RS columns are transmitted (puncturing is 64 columns). Puncturing will decrease the overhead introduced by the RS data and thus decrease the needed bitrate. The drawback of puncturing is an effectively weaker code.

5.5 Complexity and Cost considerations

From the cost and complexity point of view the main component for the time slicing is 2 Mb memory in the Receiver. When MPE-FEC is used this 2 Mb memory is reused and about 100 Kbytes is needed for the MPE-FEC decoding. The complexity estimations assume pessimistically that full RS (255, 191) decoding is used. It should be pointed out that the MPE-FEC typically works with *erasure-based* RS decoding only, in which case the decoding can be significantly simplified with a consequent effect on the complexity, which can then be further reduced.

The additional complexity introduced by MPE-FEC is low and straightforward to implement. The additional complexity of combined time slicing and MPE-FEC should be well within the maximum 20 % from the commercial requirements.

In addition it could be added that if a Receiver does not have MPE-FEC and/or time slicing functionality this could be added later, with full backwards compatibility - old Receivers would not be affected. This is due to the fact that both time slicing and MPE-FEC are backwards-compatible with traditional IP delivery over MPE.

5.6 Time slicing and Conditional Access

To support Conditional Access for DVB-H services, a fully IP based Conditional Access System (IP-CAS) could be used. As all CAS specific messaging would be on IP, the delivery of such messages could use Time-sliced elementary streams, ensuring power saving for a Receiver. Note, however, that the DVB-H environment does not necessarily support a bi-directional connection between the CAS and the Receiver. The IP-CAS would need to support a broadcast environment, if a return channel is not supported by the DVB-H end-user equipment.

To support Conditional Access for DVB-H services, the DVB common scrambling algorithm on Transport Stream packets can also be used (DVB-CAS). A DVB-CAS uses ECM messages to deliver keys for de-scrambling. The delivery of ECMs is not Time-sliced, the receiver needs to get one ECM at wakeup in order to decipher the upcoming slice. Also, a typical DVB-CAS sends EMM messages - to deliver entitlement management messages. EMMs are Time-sliced.

The rest of the current clause concentrates on the issues specific for DVB-CASs.

To ensure that a Receiver has the key for de-scrambling before a burst of scrambled data is received, the appropriate ECM has to be received before the burst. To do so, a Receiver may switch on before the burst, to wait for an ECM message. ECM_repetition_rate_descriptor announces the minimum repetition rate for ECM messages. If a Receiver switches on at least the announced time before the beginning of the burst, the Receiver should receive at least one ECM message and get the required key before the beginning of the burst.

Each multiplex of a network using DVB-CAS has to deliver EMM messages to all Receivers supported on the network, and therefore the interval between two consecutive EMM messages on a Transport Stream may be relatively short. To support power saving, a method to time slice the delivery of EMM messages is introduced.

To use time slicing for the delivery of EMM messages, the EMMs have to be encapsulated into IP datagrams. Time slicing the stream of IP encapsulated EMM messages is not different from time slicing any other IP stream. Also the MPE-FEC method may be used to decrease the Packet Loss Ratio of EMM messages. From a Receiver point of view, the IP stream carrying EMMs is an additional service, which it has to receive. The Receiver does not need to know the content of the IP datagrams carrying EMMs, but the IP datagrams are delivered to the DVB-CAS specific module in the end-user equipment, and that module then is responsible to process the payload of the datagrams.

Note that the time slicing of EMM messages does not have any effect on the above mentioned restriction on roaming between networks.

The use of DVB-CAS has a slight effect on details described in the clause 5.3.5 (about Burst Sizes and Off-times) above. Particularly some modifications are required for the introduced formulas. Below these modifications are given. The new parameter **ECM Synchronization Time** (Ca) corresponds to the time required to receive an ECM message before a data burst.

Bd	Burst Duration (seconds)	$\mathbf{Bd} = \frac{\mathbf{Bs}}{\mathbf{Bb} \times 0,96}$
Bs	Burst Size (bits)	
Bb	Burst Bitrate (bits per second)	
Cb	Constant Bitrate (bits per second)	$\mathbf{Ot} = \frac{\mathbf{Bs}}{\mathbf{Cb} \times 0,96} - \mathbf{Bd}$
Ot	Off-time (seconds)	
St	Synchronization Time (seconds)	
Ps	Power Saving (per cent)	$\mathbf{Ps} = \left(1 - \frac{(\mathbf{Bd} + \mathbf{St} + \mathbf{Ca} + (3/4 \times \mathbf{Dj})) \times \mathbf{Cb} \times 0,96}{\mathbf{Bs}}\right) \times 100 \%$
Dj	Delta-t Jitter (seconds)	
Ca	ECM synchronization time (seconds)	

Figure 5.15: Formulas to calculate the length of a burst, Off-time and the achieved saving on power consumption in case DVB-CAS is used

Assuming the Burst Size is 2 Mb, the Burst Bitrate is 15 Mb/s, the Constant Bitrate is 350 Kb/s, Synchronization Time is 250 ms, Delta-t Jitter is 10 ms, MPE-FEC not supported, and the ECM Synchronization Time has the default value (100 ms), the achieved power saving would stay a little under 92 %. For 1 Mb/s Burst Bitrate, the power saving would be 58 %, for 2 Mb/s it would be 76 %, 89 % for 7 Mb/s and 91 % for 14 Mb/s. For simplicity, one could consider the effect of ECM Synchronization Time being much the same as a slight increase of Delta-t Jitter would cause.

5.7 Memory issues

5.7.1 Memory usage

The way MPE-FEC and buffers memories are used may vary a lot between different implementations. This clause describes one possible option in order to show what the possible effects of memory limitations in receivers are.

During the reception of a MPE-FEC service, all MPE IP packets should be stored in the MPE-FEC memory inside the receiver. At the end of the frame, the buffer in the MPE-FEC memory is ready for the RS decoding which will be fixing the errors in the buffer. After that, the receiver should be able to give the correct/corrected IP packets to the higher OSI layer. After this is done, the buffer should be free in order to be ready for the next frame.

The output data rate should be high enough to be able to get all IP packets out of the MPE-FEC memory before the arrival of the next frame.

Figure 5.16 shows the processing of a service (service 0).

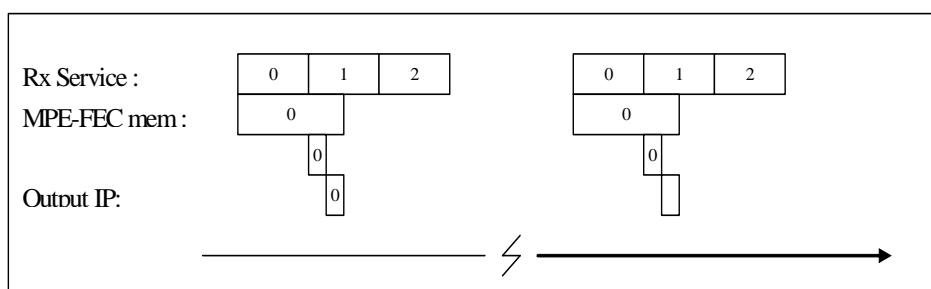

Figure 5.16: Example of service processing in the receiver

The normal approach of the DVB-H service organization is to put several services one after the other. In the current example only 3 services are shown, and the receiver is processing the service 0. While the service is being received, it is stored in the MPE_FEC memory. Then the RS decoding corrects the errors. After that, some time is required to output the IP packets from the receiver.

5.7.2 MPE-FEC memory size and receiver constraints

The fact that the receiver needs some time to output the data, disables the current MPE-FEC memory for receiving a service just after the first one.

Example shown in figure 5.17 shows that during the reception of service 1, the receiver is decoding and sending to the output service 0. Service 1 is then impossible to be received, if there is not extra memory to buffer the service 1, while service 0 is in process.

On the other hand, service 2 can be received without any extra memory.

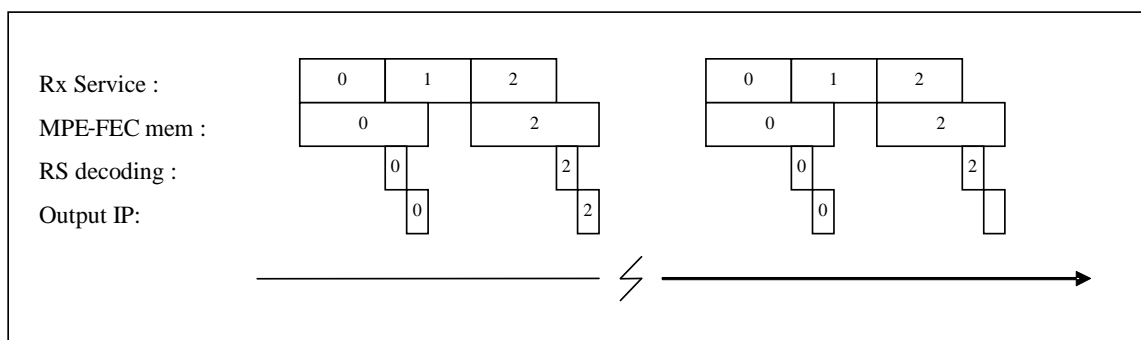

Figure 5.17: Example of two services processing in the receiver

This point is very important to perform an appropriate ordering of the services in the IP encapsulator. If two services should be received at the same time, they should not be collocated together, one just after the other. Unfortunately this constraint could cause difficulties in actual implementations. It is clear that if the receiver spends too much time sending the IP packets out, it may not be ready for the service 2 processing.

5.7.3 Minimum memory requirements

This limitation in the reception of more than one service when the receiver has not enough memory, forces to assess the memory constraints inside receivers:

- Every DVB-H receiver should have enough memory to receive at least one service in the highest memory demanding MPE-FEC mode. This mode is 1 024 rows, 191 data columns and 64 RS columns.
- This minimum memory may or may not allow the reception of several services in the same time slice, depending in the time between them.

To overcome this limitation, there are different options:

- Limit the MPE-FEC mode to 512 rows. This will demand only half of the memory for each service, and more than one service can be received at a time.

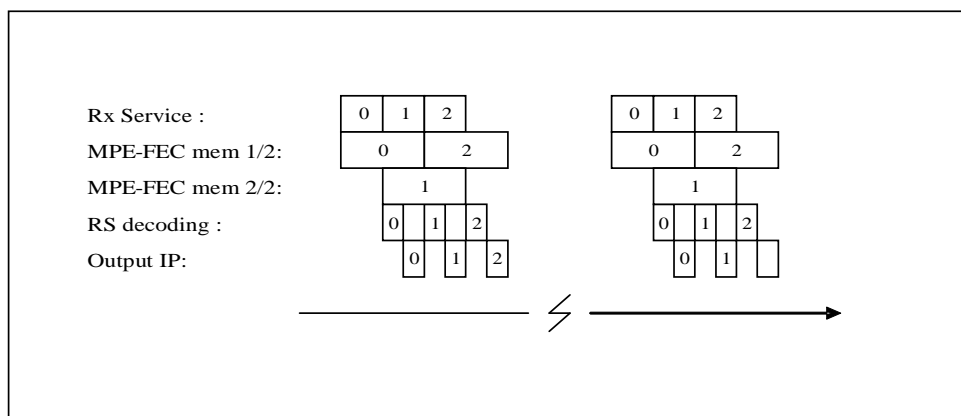

Figure 5.18: Decoding of services (MPE-FEC mode: 512 rows)

- Add more memory to the receiver to buffer incoming services while others are in decoding phase.

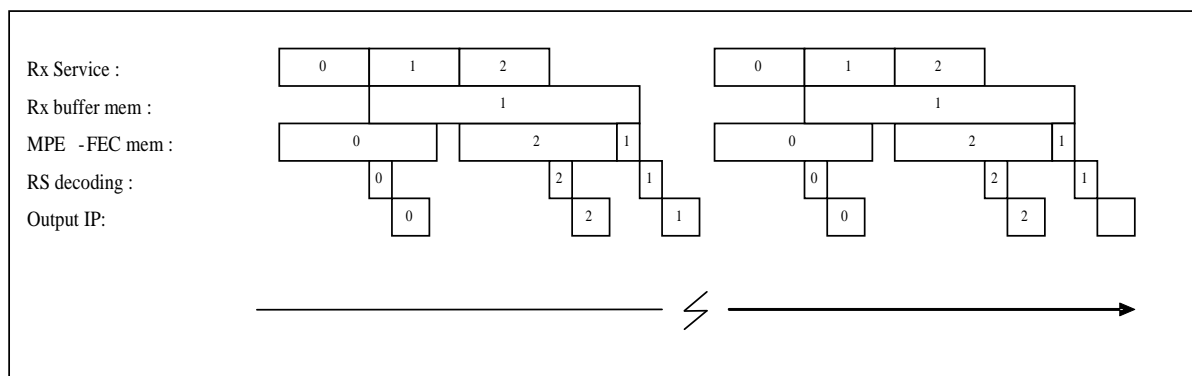

Figure 5.19: Decoding of services (extra receiver memory)

If there is a need of receiving more than one service at the same time, the limitation due to memory size may become important.

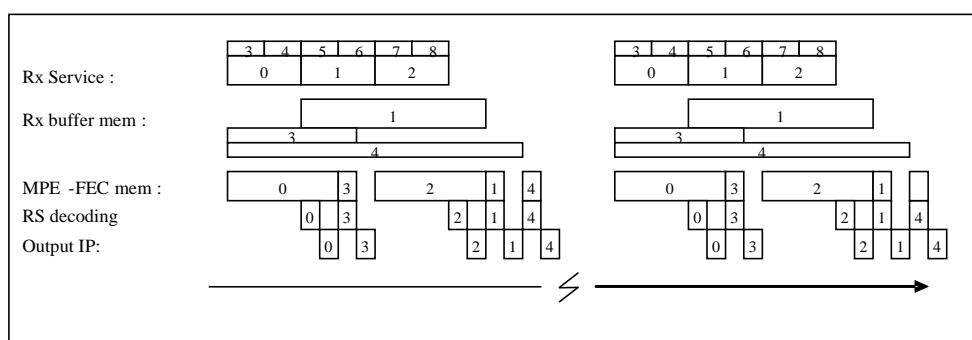

Figure 5.20: Decoding of parallel services

In the case shown in figure 5.20, the option of reducing to 512 the amount of rows may not be enough to manage all the wanted services.

5.7.4 Conclusion

The trade-off between amount of receiver memory and amount of services to be received in parallel produces different receiver's configurations. This actually means that some receivers will be able to receive many parallel services, and some others not, depending on the IP Datacast network configuration.

6 Physical layer elements: TPS bits, 4K mode and in-depth interleavers

6.1 4K mode

6.1.1 General considerations

DVB-H includes a new transmission mode in the DVB-T Physical layer using a 4 096 FFT size: the 4K mode. In addition to the 2K and 8K transmission modes provided originally by the DVB-T standard, the 4K mode brings additional flexibility in network design by trading off mobile reception performance and size of SFN networks. The proposed 4K mode is also architecturally / hardware compatible with existing DVB-T infrastructure, requiring only minor changes in the modulator and the demodulator. These points are discussed further in clause 7.

Figure 6.1 shows the blocks in the DVB-T system, which are affected by the addition of the 4K mode.

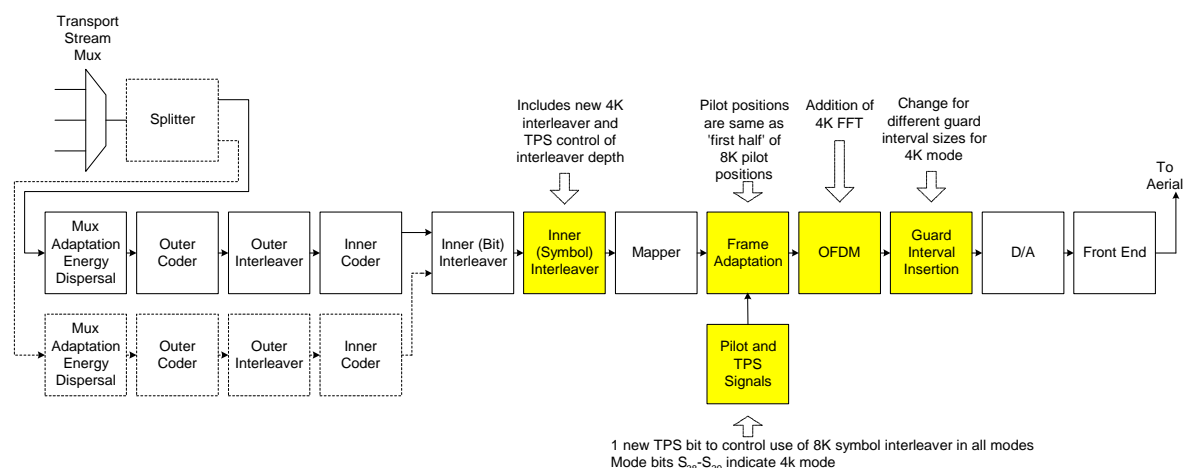

Figure 6.1: Functional block diagram of the DVB-H transmission system

DVB-H is principally a transmission system allowing reception of broadcast information on single antenna hand-held mobile devices. In the DVB-T system, the 2K transmission mode is known to provide significantly better mobile reception performance than the 8K mode, due to the larger inter-carrier spacing it implements. However, the duration of the 2K mode OFDM symbols and consequently, the associated guard intervals durations are very short. This makes the 2K mode only suitable for *small* size SFNs, making difficult for network designers to build spectrally efficient networks. From table 6.2, it can be seen that a 4K OFDM symbol has a longer duration and consequently a longer guard interval than a 2K OFDM symbol, allowing building *medium* size SFN networks. This gives to the network designers a better way to optimize SFN networks, with respect to spectral efficiency.

Although such optimization is not as high as with the use of the 8K transmission mode, other benefits will derive from the use of the 4K mode. With a symbol duration shorter than in the 8K mode, channel estimation can be done more frequently in the demodulator, thereby providing a mobile reception performance which, although not as high as with the 2K transmission mode, is nevertheless adequate for the use of DVB-H scenarios. Furthermore, doubling the sub-carrier spacing with respect to the 8K mode, allows for mobile reception with reasonably low complexity channel estimators, thus minimizing both power consumption and cost of the DVB-H receiver.

The incorporation of a 4K mode provides a good trade off for the two sides of the system: spectral efficiency for the DVB-H network designers and high mobility for the DVB-H consumers. Also, the 4K mode increases the options available to flexibly plan a transmission network whilst balancing coverage, spectral efficiency and mobile reception capabilities.

6.1.2 Performance description

The 4K mode constitutes a new FFT size added to the native DVB-T 2K and 8K FFT sizes, all other parameters being the same. As the C/N-performance with the three channel models is FFT size independent, it is safe to expect that the new 4K size will offer the same performance as the other two modes in AWGN, Rice and Rayleigh channels.

The real target of the new 4K mode is the performance enhancement in mobile reception. The current DVB-T standard provides excellent mobile performance with 2K modes, but with 8K modes the performance is unsatisfactory, especially with reasonable receiver cost/complexity. On the network planning side, the short guard interval the 2K mode implements effectively prevents its usage in the allotment type of planning, where rather large geographical areas are covered with one frequency (i.e. Single Frequency Networks - SFN). For these reasons, a compromise mode between the 2K and 8K, would allow acceptable mobile performance on the receiver side whilst allowing more economical and flexible network architectures.

For mobile and portable reception the most usable modulation scheme is 16QAM with code rate of 1/2 or 2/3, which require moderate C/N and provide sufficient transmission capacity for DVB-H services. It can be estimated that the mobile performance in Typical Urban channel conditions with 8K - GI: 1/4 transmitted at 500 MHz, is 65 km/h for CR = 2/3, and 86 km/h for CR = 1/2. These speeds were achieved with the *Motivate reference receiver*, which employed a moderately complex channel estimation, to obtain significantly better results than most of the DVB-T receiver designs optimized for fixed reception. Better performance can be expected in an 8K context, but at the expense of advanced channel estimation and ICI-cancellation techniques, which will probably add cost, complexity and power consumption to the receiver; effects which clearly oppose to the DVB-H objectives.

The 4K should provide roughly 2 times better Doppler performance than 8K. By using this rule and performing linear interpolation between the known 2K and 8K performance figures of the *Motivate reference receiver*, the following table of the predicted 4K mobile performance can be produced.

Table 6.1: C/N(dB) for PER = 10⁻⁴ in Typical Urban Channel for single antenna receiver

4K mode expected mobile performances in TU6 channel profile																	
GI = 1/4				2K				4K				8K					
Code Rate	Bitrate	C/N Rayleigh	C/N min	Fd max	At C/N min + 3dB			C/N min	Fd max	At C/N min + 3dB			C/N min	Fd max	At C/N min + 3dB		
					Fd	500 MHz	500 MHz			Fd	500 MHz	500 MHz			Fd	500 MHz	500 MHz
QPSK	1/2	4,98 Mbps	5,4 dB	13,0 dB	201 Hz	169 Hz	365 km/h	13,0 dB	133 Hz	112 Hz	242 km/h	13,0 dB	65 Hz	55 Hz	119 km/h		
QPSK	2/3	6,64 Mbps	8,4 dB	16,0 dB	167 Hz	135 Hz	291 km/h	16,0 dB	111 Hz	90 Hz	194 km/h	16,0 dB	55 Hz	45 Hz	97 km/h		
16-QAM	1/2	9,95 Mbps	11,2 dB	18,5 dB	142 Hz	114 Hz	246 km/h	18,5 dB	96 Hz	77 Hz	166 km/h	18,5 dB	50 Hz	40 Hz	86 km/h		
16-QAM	2/3	13,27 Mbps	14,2 dB	21,5 dB	113 Hz	96 Hz	207 km/h	21,5 dB	74 Hz	63 Hz	136 km/h	21,5 dB	35 Hz	30 Hz	65 km/h		
64-QAM	1/2	14,93 Mbps	16,0 dB	23,5 dB	90 Hz	75 Hz	162 km/h	23,5 dB	60 Hz	50 Hz	108 km/h	23,5 dB	30 Hz	25 Hz	54 km/h		
64-QAM	2/3	19,91 Mbps	19,3 dB	27,0 dB	52 Hz	39 Hz	84 km/h	27,0 dB	36 Hz	27 Hz	58 km/h	27,0 dB	20 Hz	15 Hz	32 km/h		

Figure 6.2 tentatively illustrates the expected mobile performance for 16QAM constellation of the 4K mode in comparison with the 2K and 8K transmission modes. It can immediately be seen that the 4K "maximum speed" performance are clearly adequate with the Quality of Service (QoS) targeted by DVB-H, when compared with the 8K figures.

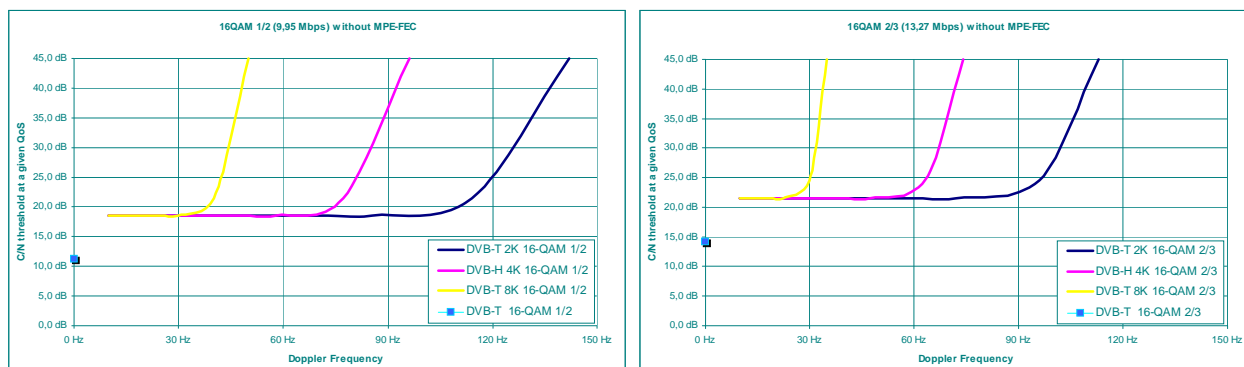

NOTE: As a "rule of thumb", if the transmission channel is located at 540 MHz, to obtain a rough approximation of the corresponding speed in km/h, multiply by two the Doppler frequency.

Figure 6.2: 4K versus 2K and 8K

As far as time domain criteria are concerned, the design of SFNs is rather straightforward with the 4K mode. The theoretical radius of an SFN area is proportional to the maximum echo delay acceptable by the transmission system, which depends on the guard interval value. For the 4K mode, this SFN radius is 2 times larger than the 2K one and half of the 8K one.

Table 6.2 shows the guard interval lengths in time. It shows how the guard interval values and therefore the size of SFN cells for 4K mode fall between the values offered by 8K and 2K modes.

Table 6.2: Guard interval lengths for all modes

	8K	4K	2K
1/4	224 μ s	112 μ s	56 μ s
1/8	112 μ s	56 μ s	28 μ s
1/16	56 μ s	28 μ s	14 μ s
1/32	28 μ s	14 μ s	7 μ s

The remaining impact of the new 4K mode to the network planning would be minimal, as the 4K has similar spectrum mask characteristics and protection ratios as current DVB-T.

The 4K mode used in conjunction with the in-depth interleaver (8K interleaver with 4K and 2K symbols) may have an impact on the impulse interference tolerance as in this case the bits of one symbol are spread over two 4K symbols providing a better time diversity.

6.1.3 Complexity, Cost and other Commercial Requirements considerations

Compared to an existing 2K/8K DVB-T receiver, the addition of the 4K mode and of the in-depth symbol interleaver does not require extra memory, significant amounts of logic, or extra power.

Also, it could be envisaged that the future DVB-H demodulators will be designed to support only the subset of the standardized transmission modes that are most suitable for mobile applications. For example, memory sizes could be drastically reduced if there was no requirement for mobile reception of 8K signals. Complexity and power consumption could be also reduced if 64-QAM and high code rates were not required.

These savings would partially offset the increase in the silicon area, and then the power consumption, required for more advanced mobile receiver algorithms such as complex channel estimation.

On the network side, it is expected that the changes in the transmitter will be only marginal since they are only located in the modulator. In addition, the emitted spectrum is similar to existing 2K and 8K modes thus no changes in expensive RF transmitter filters are necessary.

6.2 In-depth interleaver for 2K and 4K modes

The longer symbol duration of the 8K transmission mode makes it more resilient to impulsive interference. For a given amount of noise power occurring in a single impulsive noise event, the noise power is averaged over 8 192 sub-carriers by the FFT in the demodulator. In the 4K and 2K transmission modes, the same amount of impulse noise power is averaged only over 4 096 and 2 048 carriers, respectively. The noise power per sub-carrier is therefore doubled for 4K and quadrupled for 2K when compared with 8K.

The use of the 8K symbol interleaver for 2K and 4K helps to spread impulse noise power across 2 symbols (for 4K) and 4 symbols (for 2K). If only one symbol suffers such an impulse noise event, then at the output of the interleaver, 4 consecutive symbols in 2K would each have one carrier in every 4 with some noise whilst in 4K, one carrier in every 2 would have some noise over two symbols. This extended interleaving allows 2K and 4K modes to operate with impulse noise immunity quasi-similar to that of an equivalent 8K mode.

When using in-depth interleavers in SFN configuration it should be taken into account that, due to SFN synchronization, an additional delay of 1 OFDM symbol for the 4K mode and 3 OFDM symbols for the 2K mode, so the additional delay should be compensated.

6.3 TPS-bit Signalling

TPS-bit signalling provides robust multiplex level signalling capability to the DVB-T transmission system. TPS is known to be very robust signalling channel as a TPS-lock in a demodulator can be achieved with a very low C/N-value. It is also much faster to demodulate the information carried in the TPS than for example in SI or in the MPE-header. Accordingly, they have been used in DVB-H to signal both the time slicing and MPE-FEC as well as the 4K mode option.

Unused combinations of the precious TPS bits have been used to signal the new DVB-H transmission parameters:

- The 4K mode, to be used for dedicated DVB-H networks, is signalled as an additional transmission mode to the existing 2K and 8K modes.
- The DVB-T hierarchy information is used to specify the symbol interleaver depth (i.e. native or in-depth).
- The cell identifier, which is optional for traditional DVB-T services, becomes mandatory in DVB-H. Please notice that in the case of SFN networks there is only one cell identifier for the whole network.

Two formerly unused TPS bits have been allocated for DVB-H signalling:

- A time slicing indicator to signal that at least one time-sliced DVB-H service is available in the transmission channel.
- A MPE-FEC indicator to signal that at least one DVB-H service in the transmission channel is protected by MPE-FEC.

In case of non-hierarchical transmission, these time slicing and MPE-FEC indicator bits are constant as long as the DVB-H transmission parameters remain unchanged. In case of hierarchical transmission, as for the coding rate, the time slicing indicator and the MPE-FEC indicator signal independently the LP stream parameters and the HP stream parameters by using the successive OFDM frames of the super-frame.

It is important to mention that in case of SFN networks, the MIP packet should also carry all the TPS signalling bits, as it is sometimes used by the modulators to build the new TPS bits.

7 DVB-H/DVB-T compatibility issues

7.1 Time slicing and MPE-FEC

As time slicing and MPE-FEC constitute processes applied at the Link layer (OSI Layer 2) they do not raise any incompatibility issues and are fully compatible with the existing DVB Physical layer (OSI layer 1) (i.e.: DVB-T, DVB-S and DVB-C). Moreover, the interface of the network layer (OSI layer 3) supports bursty incoming of datagrams, and is therefore fully compatible with time slicing.

Time slicing and MPE-FEC modify the MPE protocol in a fully backward compatible way. Allocating bytes of the MAC_address fields, located in the MPE section header, for delivering DVB-H specific parameters is fully supported by the DVB-SI standard [i.4].

Time slicing and MPE-FEC may be used in a multiplex together with non-Time Sliced and non-MPE FEC services. Traditional DVB IRDs may continue receiving non-Time Sliced and non-MPE FEC services, as time slicing and MPE-FEC has no effect on reception of those services.

Time slicing may however require a reasonable bitrate to be allocated for Time Sliced services only, therefore possibly affecting the bitrate available for non-Time Sliced services. Traditional DVB IRDs may be used for receiving Time Sliced and MPE-FEC services, provided it does not reject the used stream_type. Such IRDs would simply ignore the DVB-H features, namely the delta-t parameter and the FEC data, and will stay on during the Off-time periods. However, traditional DVB IRDs may or may not be able to receive (i.e. to store) data streams on the higher bitrate used during service bursts, which may limit usage of such IRDs to receive Time Sliced services. This is not a compatibility issue from a standards point of view, as the Data Broadcast standard (EN 301 192 [i.6]) sets no limitations on used bitrates.

A Receiver receiving a Time Sliced elementary stream may need to support IP datagram buffering of up to 256 kBytes. Players of streaming services (over IP) set even greater requirements for initial buffering. Therefore a Receiver supporting IP streaming has to support the required buffer, regardless of whether it supports time slicing or not.

Note also, that a specific *stream_type* has been defined for an elementary stream supporting time slicing and/or MPE-FEC, while an elementary stream not supporting time slicing nor MPE-FEC may use a wide range of *stream_type* values (value 0x0D and 0x80...0xFF are allowed). The reason for allocating a new *stream_type* was the fact that 0x0D does not allow delivery of any other sections but MPE whereas the use of the MPE-FEC method requires MPE-FEC sections, too. For simplicity, an elementary stream using only time slicing (but not MPE-FEC) also uses the new *stream_type*.

Many - if not all - existing traditional DVB IRDs can be modified to support time slicing by simply updating the system software. However, there may not be adequate reasons to update a traditional DVB IRD, as in most cases it is probably not required to enable reception of Time Sliced elementary streams.

7.2 DVB-H signalling

DVB-H signalling is fully backward compatible as all signalling is done in "reserved for future use" bits. Currently unused bits are ignored by the DVB-T receivers.

7.3 Added 4K mode and in-depth interleavers

The proposed new 4K-mode and in-depth symbol interleaver for the 2K and 4K modes indeed affects the compatibility with the current DVB-T physical layer specification, since the former receivers could not decode a DVB-H signal employing these transmission modes. However they are "compatible" with the current DVB-T specification in some ways:

Spectrum requirements

At the highest level they are fully compatible with the current spectrum requirements of 2K and 8K DVB-T modes (this being obvious for the non-native interleaver modes); the occupied bandwidth being the same as well as the shape and interference characteristics.

System level

The next level of compatibility is at the DVB-T system level. The new 4K mode could be considered just as an interpolation of the existing 2K and 8K modes, requiring only an additional parameter in the DVB-T system and a little control logic in the equipment; this upgrade being 100 % compatible with other blocks of the system (the same way that some 2K receivers cannot decode an 8K transmission, but being both modes 100 % DVB-T). Besides, as most of the current DVB-T equipment includes both 8K and 2K FFT-modes, the additional complexity is minimal consisting mainly of additional control logic.

Receivers

For the receiver, it is obvious that current 2K or 8K receivers will be unable to receive 4K signals, but this is not a severe restriction as any new DVB-H network using the 4K mode would be targeted towards new services and new types of hand portable terminals. The only restriction in this case arises when sharing the multiplex between traditional DVB-T and DVB-H services. The standard allows new 4K-capable receivers to receive both 2K and 8K transmissions; the actual implementation of all modes being a commercial decision. Another receiver level compatibility consideration is the relative simplicity of adding the new 4K mode to the existing 8K/2K chip designs. This ensures low cost and fast time to market for the 4K capable DVB-H hardware.

8 DVB-H services

8.1 Service scenarios

DVB-H is system especially suitable for the mobile environment. There are also challenges in mobility, as there are no constant conditions in the radio interface. Instead, the field strength and phase of the received signals varies, the multi-path propagation might cause long delay spreads, the cells changes, etc., which means, in the worst case, that part of the data is lost during the transmission.

8.1.1 Effects of the Environment and equipment

The mobility of DVB-H gives the user the possibility to carry the receiver to the environments that have not been usually used in earlier terrestrial broadcast systems. This gives special points of view for the network planning, as the radio conditions vary depending on the location of the mobile.

Furthermore, the offered services should be planned to be appropriate for the mobile terminals, which, in many cases consist of relatively small display.

8.1.1.1 Slow moving DVB-H terminal

The relatively small DVB-H terminals can be used practically everywhere the signal is found. For this reason, there are some issues to be taken into account as network and service planning is considered.

Pedestrian users can use the slow moving mobile in such places that cannot be covered by DVB-H cells. Because of the very small internal antenna of the terminal, the received power level might be the limiting factor e.g. inside buildings.

Vehicle mounted equipment is rather straightforward solution for the DVB-H reception, since the equipment might be connected to the external antenna placed on the rooftop of the vehicle. In this solution, the antenna gain is typically considerably better than with the pedestrian use. The estimation of the external car antenna gain is from 2 dBi to 5 dBi, whereas the hand held mobile with internal antenna might have estimated antenna gain of between -5 dBi to -10 dBi.

8.1.1.2 DVB-H in fast moving mobile

There are some special environments where DVB-H terminal can move relatively fast. A "Bullet train" is one example of this environment. In this case, it should be noted that the train itself might attenuate the signal strength considerably when using a hand-held DVB-H device with an internal antenna. This phenomenon can be minimized by installing repeaters inside the train, with possibly a leaking cable solution. The functioning of the system in high-speed environments also depends on the used modulation and mode.

The recommendation for in-car antenna height value (for calculation purposes) is the standard 1,5 m. As the average practical antenna height inside cars might be lower than this, whilst the value inside trains is normally higher, the 1,5 m value represents a reasonable average for calculations.

The 2K and at some extent the 4K modes, of DVB-H are meant for the possible future use of the system, especially in the very fast moving vehicles (like bullet trains). These modes would also work properly in higher frequencies than in traditional broadcast bands.

8.1.2 Services

The varying characteristics of the radio interface means that the end-user experiences a different level of reception quality depending on where the services are used.

Nevertheless, some of the most interesting characteristics of DVB-H from the service design perspective are:

- the high broadcast data rate even in moving conditions compared to other technologies;
- the simultaneity of reception of the information by all listening users, together with a real-time capacity;
- the ability to cope with highly simultaneous demands with no risk of network saturation;
- and the simplicity to address a community of users thanks to the support for multicast protocols.

There are different ways of classifying services depending on, for example:

- the market (i.e. professional, entertainment, educational, wealth, traffic information, etc.);
- the network use (i.e. distribution, retrieval, messaging, conversational);
- the functionality and level of interactivity proposed to the end-user.

This clause intends to propose a classification of potential DVB-H services.

8.1.2.1 Real-time Applications

One of the clear benefits of DVB-H is the possibility of delivering real-time services for vast audiences in a certain area.

TV-like broadcasting

In this case, the hand-held set can be used as digital TV broadcast receiver with the possibility of selecting the wanted channel. The selection procedure is simple, the Electronic Services Guide (ESG) being the method of informing about the contents available on the channels.

The first step for introducing this type of service is to simulcast the existing broadcast programs on a terrestrial fixed network and DVB-H network. This approach is the one chosen in Asia for the moment, with handsets that feature a built-in analogue TV tuner. But, it has to be taken into account that consumption of TV on a handset in nomadic situations is different from the consumption at home: short time period, small screen devices, etc. and contents will have to be adapted to these characteristics.

Next step is already announced in Japan for 2005 - 2006 with the shipping of digital TV tuners integrated into mobile phones, to provide news, TV shopping and sports services specific to the area and conditions of reception.

Of course, this scenario also applies to high quality radio programs being received through handsets, eventually together with additional contents (images, textual information, etc.).

Live broadcasting and notification

Accessing a broadcast channel in nomadic situations is particularly interesting for receiving real-time information, and especially contents linked to events, whether sports, news or other very attractive programs such as reality TV.

A DVB-H network will allow the development of such services, with broadcast notifications sent according to the preferences of the user (stored in the service provider server) to be chosen at the time of subscription to the service with the possibility for the service provider to propose different fees, depending on the number of notifications to which the user subscribes.

For example, a football fan of the BEST team should be notified of the retransmission of his preferred team matches, and if he cannot view the whole match, should be notified each time the team scores, with the possibility to view the corresponding action. All the subscribers with same preferences would receive the notification at the same time and be able to see the goal. Same can be applied for news, with a segmentation done on the type of news: politics, specific affair of the moment, etc. Finally, surfing on the wave of reality TV, one can imagine contents that incite users to participate in the show in real-time, by voting or chatting, etc.

This live broadcasting should be also applied within shopping malls to broadcast advertisements and special offers related to these ads.

Games

Games, whether real-time quizzes or multiplayer online role-playing games, are other real time services that should be supported over DVB-H network.

The first one consists on a broadcast quiz, linked or not to a broadcast program, allowing the user to compete with other users. Real-time results can be broadcast. The second scenario consists of mobile online games dedicated to a community of players.

The DVB-H link is then used to broadcast the persistent environment of the game, the updates of the game as well as the results of the actions of the connected players and a mobile telecommunications network, such as GPRS, is used to transmit the user actions to the service server for interpretation.

8.1.2.2 Near on-demand Applications

DVB-H is suitable for the reception of near on-demand video and audio streams from, for example, a pre-defined selection of programs. Video and audio streams are continuously streamed by the server on different "channels" accessible through a portal: e.g. cinema with movie trailers sorted by types, audio streams and video clips, news, weather forecasts, etc.

8.1.2.3 Downloaded Applications

The services in preceding sections are directly consumed by the user. In the downloaded services, contents are stored within the terminal for further consumption. As the data file transmission is vulnerable in low reliability radio conditions, efficient repetition and data error correction mechanisms are needed. Because of that, the DVB-H system would not be the first choice for a wireless data transmission method, where low error rates are needed. In addition, the system needs to include billing capabilities adapted to the different means of consumption: e.g. on a one-time basis, on a subscription basis, etc.

For large general audiences...

A typical scenario for this service is the purchase of data files.

This can be realized on a subscription basis, such as for the electronic version of the user's newspaper that is downloaded to the handset every week morning at the same time. Many other types of content can be applied to this service such as road map updates for traffic information services.

The purchase can also be impulsive one. The user may have access to a sort of electronic store, have a preview of the last audio CD from his preferred singer, see the movie trailer of films, or read some paragraphs of the latest trendy book and decide to buy the corresponding data file. The server indicates the time at which the file will be downloaded to the handset for all the users that have ordered it.

...as well as for individual purpose...

Although DVB-H is basically meant for the broadcast-type of traffic, it could be used also for the individual purposes through unicast session.

...and professional applications

These applications include the update of terminal at the bus stop to provide information on the events of the day in the localized area for example. The terminal should then deliver tickets to access the events. Some investigations could also be made on the machine-to-machine applications: software downloading to upgrade the operating system of machines, etc.

8.1.2.4 Other added-value services and applications

Convergence terminals, e.g. DVB-H+GPRS, will besides enable added-value services and applications, this clause do not intend to provide a comprehensive set of them, but to point out that applications like audience control, impulsive pay per view, etc., could be easily implemented in such terminals.

8.2 Hierarchical networks for progressive QoS degradation or multiformat/multidevice support

This clause proposes a scenario that uses "DVB-H only" hierarchical networks in order to either support a progressive QoS degradation or allow multiformat-multidevice transmissions.

8.2.1 Introduction

One of the most interesting characteristics of the DVB-H standard is the ability to build hierarchical networks. This networks share the same RF channel for two independent multiplex.

In hierarchical modulation, the possible digital states of the constellation (i.e. 64 states in case of 64-QAM, 16 states in case of 16-QAM) are interpreted differently than in the non-hierarchical case.

In particular, two separate data streams can be made available for transmission (see figure 8.1, relevant to 64-QAM): the first stream (HP: high priority) is defined by the number of the quadrant in which the state is located (i.e. a special QPSK stream), the second stream (LP: Low Priority) is defined by the location of the state within its quadrant (i.e. a 16-QAM or QPSK stream).

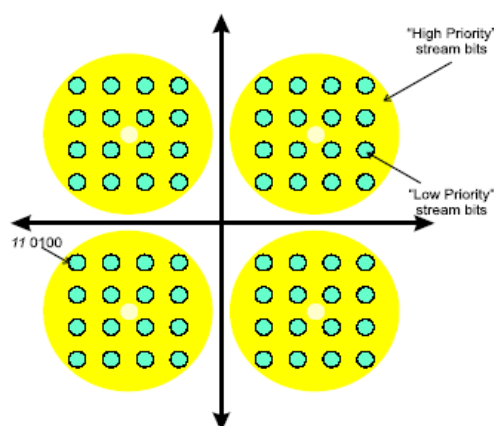

Figure 8.1: Constellation for hierarchical modulation

In example, with reference to figure 8.1, we are still dealing with 64-QAM, but, in the hierarchical interpretation, it is viewed as the combination of 16-QAM and QPSK modulation, and it is referred to as "QPSK in 64-QAM".

Moreover, a modulation parameter " α " can be chosen. Typical values are 1 (uniform modulation), 2 or 4 (non-uniform modulation).

Therefore, hierarchical modulation allows the transmission of two streams, having different bit-rates and performance, in the same RF channel.

The sum of the bit-rates of the two streams is equal to the bit-rate of a non-hierarchical stream using the same modulation (even if the net data rate is slightly lower, due to the double MPEG-2 TS overhead).

As regards performance, the better protected HP stream has about the same noise sensitivity as a standard QPSK stream, with an impairment of 1 or 2 dB due to the "noise-like" presence of the LP stream; the LP stream has the same noise sensitivity as the overall scheme in case of $\alpha = 1$, and slightly impaired in case of higher values of α .

For DVB-H, as will be assess further on, an α factor of 2 could be chosen to improve the noise sensitivity of the HP stream, spite further degrading the LP stream.

8.2.2 Network planning considerations

Hierarchical modulation is the most cost-effective modulation since it provides the most spectrum efficiency.

If planning a DVB-H service for indoor reception (for the HP stream), we could consider that all the services in the LP stream are transmitted "almost for free". The issue is the objective of such services: if they are thought for fixed antenna reception we have to consider that we are "wasting" a lot of resources, since planning a network for indoor reception requires a higher number of transmitters and/or power emitted. Whereas if they are thought to also provide coverage to portable devices indoor or for handheld devices outdoor the network topology remains the same, somehow, as mentioned previously we have an upgrade of our network "almost for free".

EXAMPLE:

QPSK in non uniform 64-QAM ($\alpha = 2$)

- HP: QPSK FEC:1/2 G.I:1/8 would allow 5,53 Mb/s having a C/N in Rayleigh channel of 8,7 dB.
- LP: 64-QAM FEC:1/2 G.I:1/8 would allow 11,06 Mb/s having a C/N in Rayleigh channel of 18,2 dB.

Overall bitrate in the channel would be: 16,59 Mb/s. There are more than 10 dB (in terms of C/N) difference between HP and LP streams, but we have to consider that:

- there are some devices that could still receive the LP even indoors, for instance due to the antenna they use (let us imagine different devices, one being an integrated GSM-DVB-H and the other being a Laptop with a DVB-H card and an external antenna);
- depending on the situation of a device there could be situations in which it is able to receive the LP (let us imagine an integrated GSM-DVB-H device receiving outdoors).

8.2.3 Scenario

This scenario is proposing the use of hierarchical modulation in "DVB-H only" networks, let us not confuse with clause 8.3.2 where it is proposed to use the hierarchical modulation to mix DVB-H with traditional MPEG-2 DVB-T services.

The benefits could be seen in three different ways:

- Progressive degradation of the QoS.
- Multiformat/multidevice support.
- Utilization of LP stream for upgrading content carried within HP stream.

8.2.3.1 Progressive degradation of the QoS

Digital transmissions are characterized by a rapid signal degradation, with DVB-H this effect is even more stressed. That obliges the use of more robust DVB-H modes and parameters; the price to pay is the decrease of the net bitrate. MPEG-4 is here the enabler since the service bitrate could be as small as 128 Kb/s (for reasonably small screen) so a number of services still enter in the multiplex.

Let us however use an example: a mobile phone with a PDA like screen. Receiving conditions are various. The mobile phone could be inside a building without windows on the first floor. Terrible conditions. But it could well be outdoors at the bus stop where we have excellent field strength.

When planning a traditional network we have to consider the worse case, this is inside the building, we use a very robust mode, low bitrate with redundancy and are obliged to use 128 Kb/s as service bitrate.

Now, let us have the hierarchical network example and let us imagine a simulcast of services (128 Kb/s in HP stream and 384 Kb/s in LP stream). The terminal could choose LP or HP depending on its locations, depending on the receiving conditions. It is well possible that we have more than 15 or 20 dB difference in the field strength in the situation previously explained in our example, so the receiver, in spite of the integrated antenna, could outdoors receive the LP stream and show a great picture quality to the user and when entering the 1st floor of the building could keep the service alive with reduced picture quality (HP stream).

We are using hierarchical modulation to have a "progressive" degradation of the QoS.

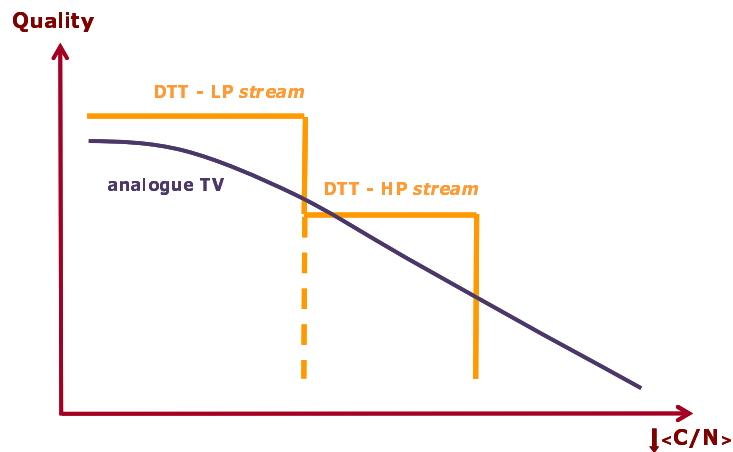

Figure 8.2: Progressive QoS degradation using hierarchical networks

8.2.3.2 Multiformat/multidevice support

There is another way to assess the situation. Not all DVB-H capable devices will be the same as we previously stated. There are devices with larger screens (therefore requiring more service bitrate) and the capability to have external antennas or at least antennas with a higher gain than handheld devices.

In this situation LP stream (although requiring a larger C/N than HP stream) could be received due to the larger antenna gain and occasionally the receiving conditions (outdoor or indoor selecting the place where the antenna is located).

The idea is to use the LP stream to provide an upgraded service to those devices, as an example we could consider a portable PC with a DVB-H enabled card, where clearly a service bitrate of 128 Kb/s could not sufficient. For example a simulcast of the services in LP and HP could be done to provide the user different quality of service levels depending on the terminal used.

Obviously, this scenario includes the previous one.

8.2.3.3 Utilization of LP stream for upgrading content carried within HP stream

In the dedicated DVB-H networks hierarchical modulation can be used to optimize bandwidth usage when the same content is provided in two different bitrates within the same signal.

Instead of using simulcasting, the content is encoded into two streams so that a first stream is configured to be transmitted with the HP stream, and a second stream to be transmitted with the LP stream. The first stream contains "normal" bitrate service. LP stream is configured to contain additional information for increasing the bitrate of the first stream. Hence, the "normal" bitrate service can be upgraded to higher bitrate service by decoding upgrade data from the LP stream. Figure 8.3 illustrates transmission scheme of the given scenario.

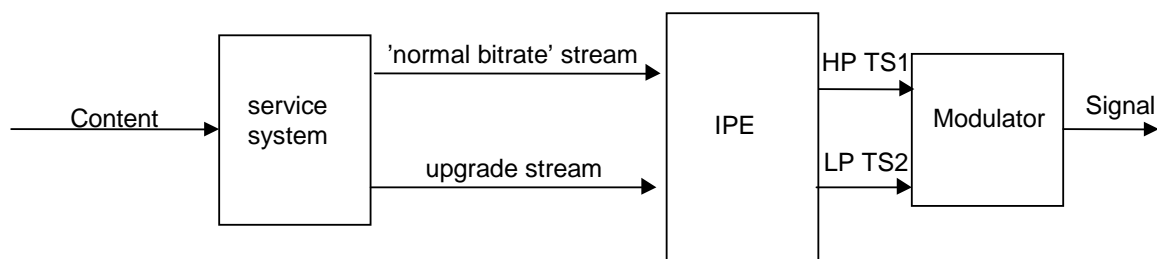

Figure 8.3: Transmission scheme of the given scenario

It should be noted, that there is a requirement to have the transmission of content within HP and LP streams phase-shifted (as shown in figure 8.4), since otherwise reception of such content would be limited only to receivers which support simultaneous reception of HP and LP streams.

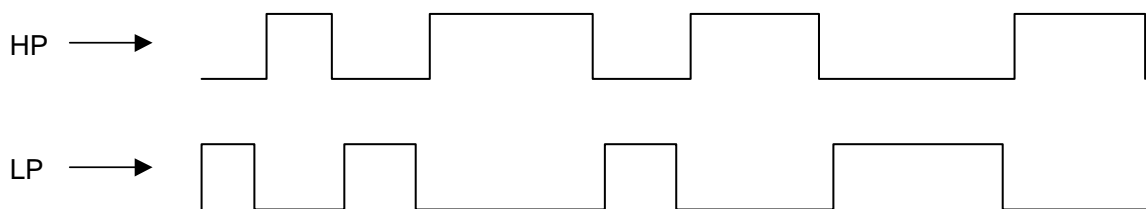

Figure 8.4: Phase-shifted transmission of content within HP and LP streams

It should be mentioned that the given scenario requires layered codec support from the receiver and this should be acknowledged when such services are utilized.

8.3 Sharing aspects with DVB-T MPEG-2 services

When DVB-H is introduced in an existing DVB-T network, the bitrate for IP services can be reserved either by multiplexing or by using hierarchical modulation. If there is no bandwidth left for DVB-H services, a DVB-H dedicated network should be built.

In the case of sharing bandwidth between traditional MPEG-2 and DVB-H services, the transmission mode is either 2K or 8K with their native symbol interleavers following the DVB-T standard. However, the DVB-T modulator needs to be modified in order to accept DVB-H signalling (TPS bits particularly S48 which means that at least one elementary stream uses time slicing).

NOTE: It should be noticed that the target for coverage (i.e. signal levels in the coverage area) for traditional MPEG-2 services (e.g. target viewer has a roof top antenna to receive the service) could be different to DVB-H services (e.g. target viewer has an integrated antenna in a mobile cellular telephone and is walking in the street). Therefore sharing the same multiplex between MPEG-2 services and DVB-H services should be carefully considered since the network topologies needed for both services could be different.

8.3.1 Multiplexing

In this scenario the DVB-H IP services are inserted to the transport stream at the multiplexer level in parallel with the MPEG-2 services.

Remultiplexing issues fall into two main themes:

- Jitter: how does jitter in the MUX and modulator chain affect timeslicing?
- PSI/SI management (ID harmonization requirements; private descriptors).

According to a survey that was done in 2nd quarter 2003 in order to evaluate these two themes, the existing multiplexers of most vendors can be used for multiplexing both DVB-H services and MPEG-2 services. Should first deployments within pilot networks show any problems, these can be expected to be minor.

The following two minor issues can make existing multiplexers more suitable for DVB-H:

- Smooth reinsertion of managed PSI/SI sections.
- Support for ID management in INT table.

By smoothing the reinsertion of PSI/SI sections, a stable amount of bitrate will be used for PSI/SI, leading to even less jitter on elementary streams carrying timesliced IP services.

Multiplexers usually manage the IDs contained in the PSI/SI tables (PAT, PMT, NIT, SDT, etc.). The goal is to re-allocate PIDs, service IDs, transport stream IDs etc in order to resolve collisions between incoming transport streams.

The INT table is currently a private section and does not participate in this ID management. Therefore, if the multiplexer changes e.g. the service ID of an incoming service that carries encapsulated IP streams, the INT table that contains the IP-to-ES mappings for this service is destroyed.

With current multiplexers, the situation can be avoided by harmonizing the IDs, so that collisions never occur. However, for improved manageability, multiplexers should also manage the INT table.

In order to introduce DVB-H services into an existing DVB-T network using multiplexing, the following steps are required, in any order:

- Timeslice-capable IP encapsulators are connected to the last-hop multiplexer, which is ideally located in each coverage area (MFN or SFN), and a fixed amount of bitrate is reserved for DVB-H services.
- The last-hop-multiplexers are upgraded for better DVB-H support (smoothing of reinserted PSI/SI tables, management of INT table).
- If necessary, improve the coverage of the DVB-T network (more cells, upgrade of single-transmitter cells to SFN-areas, addition of radio frequency repeaters).

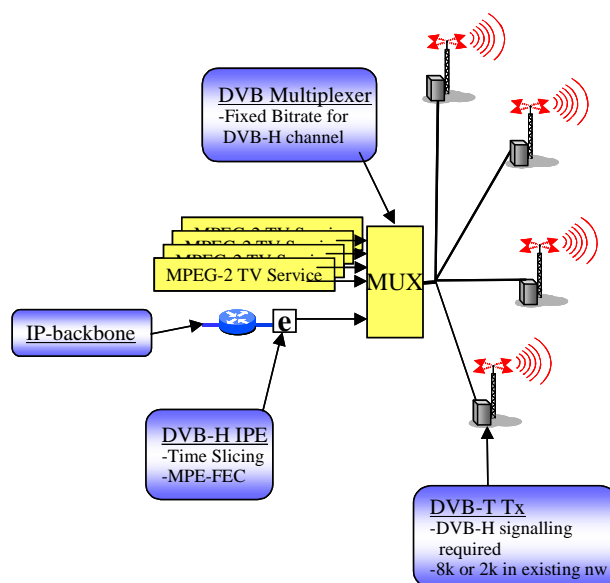

Figure 8.5: DVB-H Introduction example in existing DVB-T networks with multiplexing

The possibility to have global and local IP services is the same as in the case of a dedicated DVB-H network, and the properties of the IP backbone network are the same. The number of last-hop-multiplexers determines the granularity of service coverage areas. This is why these multiplexers (and with them the IP encapsulators) are ideally located locally in each coverage area (MFN or SFN).

For network-wide distribution of IP streams, there is now an additional option: the IP streams can be encapsulated centrally, and distributed to the sites within a centrally produced transport stream, which is then re-multiplexed by the last-hop-multiplexer to produce the final transport stream that is broadcast.

Whether or not this is a good option depends on many factors. IP networks can be expected to be cheaper, more scalable, and simpler to manage than transport stream distribution networks. But if there is capacity available in an existing transport stream distribution network, why not use it, especially if there is no IP network available.

In this case, the centrally encapsulated IP streams should not be timesliced, but simply embedded in the transport stream using normal multi-protocol encapsulation. The local IP encapsulator can then decapsulate these IP streams, and timeslice them as any other IP stream that is received over the IP backbone network.

It would be technically possible and allowed by the standard to timeslice also the centrally encapsulated IP streams, and to add locally another set of timesliced IP streams. However, this would not be optimal from power-saving perspective. As timeslicing is a technology for reduction of power consumption of a mobile handheld terminal, there is no need for central timeslicing.

The DVB-T network already being in place, the time to market depends only on the availability of a timeslice capable IP encapsulator and of timeslice-capable receivers.

8.3.2 Hierarchical Modulation

NOTE: It should be mentioned that the use of hierarchical modulation with current receivers could have compatibility problems that might be solved with firmware upgrades. The problem arises from the fact that most receivers always try to decode the High Priority stream instead of looking for the Low Priority one. DVB-H services if using hierarchical modulation would be distributed in the High priority stream therefore raising compatibility problems. This item is under study.

In this scenario the DVB-H IP services are inserted in the High Priority stream of the DVB-T modulator. The modulators are the existing 2K or 8K ones. A new TS distribution network for the HP stream is needed as well as the IP-encapsulator with DVB-H capability.

There are several advantages of using hierarchical modulation instead of multiplexing:

- There can be separate sets (though mutually dependent) of modulation parameters for fixed (DVB-T) and mobile (DVB-H) reception, leading to more optimal bandwidth usage.
- No multiplexer being involved, the jitter and ID management concerns that apply to the multiplexing scenario do not apply to the hierarchical modulation scenario.

The disadvantage is that a fixed amount of bandwidth has to be used for DVB-H, so there is no flexibility in there.

In order to introduce DVB-H services into an existing DVB-T network using hierarchical modulation, the following steps are required:

- 1) If necessary, replace modulators with models that support hierarchical mode and put a 2nd synchronized transport stream distribution system in place for modulators in SFN-areas.
- 2) Timeslice-capable IP encapsulators are connected to the modulators, or, in case of SFN-areas, to the SFN timestamp inserter.

If necessary, improve the coverage of the DVB-T network (more cells, upgrade of single-transmitter cells to SFN-areas, addition of radio frequency repeaters).

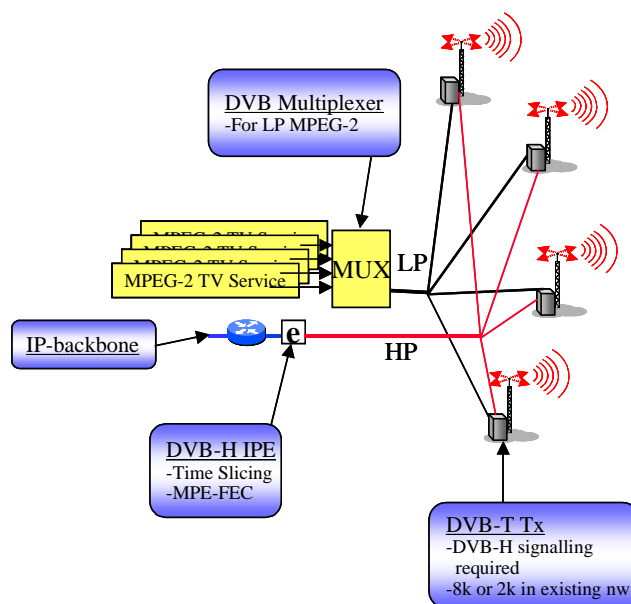

Figure 8.6: DVB-H Introduction example in existing DVB-T network with Hierarchical Modulation

From DVB-H perspective, this case is identical to having a dedicated DVB-H network, so all the comments on how to construct an IP backbone network and how to mix global and local IP streams are the same.

The time to market depends only on the availability of a timeslice-capable IP encapsulator and of timeslice-capable receivers, and on the deployment of modulators and SFN-areas that support hierarchical mode.

8.4 DVB-H service access

This clause describes a procedure for the reference receiver (see clause 10) enabling access to IP service(s) on a DVB-H network.

The following SI (Service Information) tables are involved:

- **BAT** Bouquet Association Table.
- **INT** IP/MAC Notification Table.
- **NIT** Network Information Table.
- **PSI** Program Specific Information.

The procedure consists of the following steps:

- Select one of the available transport streams.
- Select one of the available IP platforms.
- Receive the INT sub_table of the IP platform.
- Select an IP service (IP datagram stream).
- Filter for an IP stream carrying the selected IP datagram stream.

Detecting available transport streams may require signal scan. A receiver requesting support for time slicing may optimize the scan by ignoring any signals where TPS does not indicate support for time slicing. Same applies if MPE-FEC support is required (e.g. due to bad signal strength), when the receiver could ignore any signal where TPS does not indicate support for MPE-FEC. This optimization may give benefits especially when the time for signal scan should be limited to minimum.

Note that SI gives more accurate information on whether time slicing and/or MPE-FEC are supported for a particular IP stream. However, access to TPS signalling is significantly faster, giving benefits especially when accessing the signal for the first time.

When available transport streams are detected, typically the one with the best signal strength is selected.

All IP platforms supported on a particular transport stream are announced in NIT (or optionally in BAT, in which case NIT announces the BAT). To access an INT sub_table on a particular transport stream, the below described procedure may be used:

- Search NIT for linkage_descriptor with linkage_type 0x0B:
 - If found, the descriptor announces the service_id and platform_id for each available INT sub_table.
 - If not found, search for linkage_descriptor with linkage_type 0x0C.
 - If found, the descriptor announces the BAT where linkage_descriptor with linkage_type 0x0B is available.
 - If not found, INT is not available, and IP services (if any) on the actual DVB network cannot be accessed.
- Search PMT sub_table using the service_id from the step 1.
- The PMT announces the elementary stream carrying a particular INT sub_table.

Note that selecting one of the INT sub_tables effectively selects the associated IP platform.

INT announces access parameters for IP streams, and associates each IP stream with an IP datagram stream. The access parameters consist of parameters to identify the DVB network (network_id), the transport stream (original_network_id and transport_stream_id), the DVB service (service_id) and the component (component_tag).

Selecting IP platform is typically done by the user.

To receive an IP service, INT sub_table of the IP platform supporting the service is checked, to get access parameters for each of the IP datagram streams carrying the elements of the service.

Using the access parameters, receiver searches for the PMT sub_table (identified by the service_id), which then announces the elementary stream (identified by the component_tag) carrying the requested IP stream. On the elementary stream, the receiver typically would filter the IP stream based on IP address.

8.5 Handover considerations

8.5.1 Requirements

A general description of the handover requirements may be found in clause 4.5.4.1 of the "Guidelines for the implementation and usage of SI" of TR 101 211 [i.3].

A mobile device, by its nature, is subject to move from one coverage cell to another (understanding by coverage cell, the area in which there is coverage from one or more transmitters in SFN).

A major benefit of timeslicing is that the receiver may take advantage of the service off time to apply a handover strategy. This period allows the receiver to look for services in the adjacent cells while the current service is still being displayed.

One can basically distinguish between the following three cases:

- 1) Handover to the same Transport Stream (TS).
- 2) Handover to another TS - fixed phases of bursts.
- 3) Handover to another TS - dynamic phases of bursts.

Case (1) is straightforward since precise time synchronization of a TS can easily be accomplished via the same methods as Single Frequency Networks, i.e. via the use of the DVB-SFN specification (using the MIP). Note that phase shifts (as described in clause 8.5.6) are not appropriate in this case because any significant phase difference between different versions of the same TS would introduce an unacceptable difference in delay, which would be directly in opposition to seamless handover.

In case (2) systematic fixed phase shifts are used. Note that phase shifts as such in this case do not introduce any difference in delay, since the content (i.e. the IP packets) of a particular burst on a first TS (TS1) is only partly identical to any burst on a second TS (TS2). This solution does not require any specific signalling - if the network operator sets up the network with the appropriate phase shifts a receiver could always perform seamless handover even without specific signalling. A receiver would know the difference between case (1) on the one hand and case (2)/case (3) on the other hand by the Transport_stream_id, which would be the same in case (1) but different in case (2)/case (3).

Case (3) is a very important case in the long term, since in mature DVB-H networks dynamic phases will most probably be unavoidable sooner or later and it is desirable to enable seamless handover also in this case. This is also possible without any specific signalling. A receiver, which expects its new burst of TS1 at $t = t1$ could always move to the frequency of TS2 and wait there to see if any burst arrives before it has to go back to TS1 and receive the new burst at $t = t1$. In a situation with completely random burst phases this would enable the receiver to perform seamless handover with a fairly high probability. If the handover is not successful in the first attempt (i.e. the receiver has to go back to TS1) it can try again one or more burst cycles later, when the phases have shifted.

The receiver will detect the transition from one cell to another by detecting that signal strength has dropped below an acceptable threshold. This detection may be achieved by various means, some of them taking into account evaluation of the error rate.

When the receiver enters a new cell, it tunes to a new frequency and then confirms that the multiplex is carrying the correct service.

Different strategies may be used to select such a new frequency; a non exhaustive list may be:

- signal scan;
- use of NIT and frequency_list_descriptor;
- use of cell information via TPS and NIT;
- use of INT table (for IP based services).

These mechanisms are based on relevant information inserted in the signal.

These different strategies are presented and discussed in the following clauses.

8.5.2 Signal scan

This is the most basic strategy which can be initialized without specific broadcast information. Signal scan is needed when the receiver holds no information of the existing DVB-H signals and networks. Respectively, it can be used for updating the availability of DVB-H signals e.g. in case where NIT_other is not supported by the network.

When the receiver holds no information of the available signals (i.e. it is started first time or after been switched off and then moving long distance) it enters this process. The receiver may scan the whole transmission band (e.g. 474 MHz to 698 MHz, see IEC 62002-1 [i.7]), or test specific frequencies, for instance frequencies previously used to decode the same service (as an example, if the end user lives in Paris, the greatest probability is that the receiver tunes to one of the frequencies used in Paris). So the receiver tests a frequency, tries to lock to the signal and when locked, inspects the Time Slicing indicator from TPS bits. If this is not available, the receiver discards the signal and proceeds to next one. Once a signal with Time Slicing Indicator is found there are two options, which depend on whether the signalling of NIT_other is supported by the network.

- a) NIT_other supported:
 - 1) Receiver inspects NIT_actual and NIT_other of the found signal and stores announced signals as possible handover candidates.
 - 2) Scanning can be terminated and found signals can be used as handover candidates or as input for different iterations enabled by other methods.
 - 3) Signal scan is no longer required if the following clauses are true:
 - a) Receiver holds information of at least one DVB-H signal and is able to access to it.
 - b) NIT_other is supported by the network that the signal is part of.
- b) No NIT_other support:
 - 1) The receiver continues the scanning process until the end of frequency range (e.g. until frequency 698 MHz). The set of scanned frequencies can be optimized based on the found NIT_actual subtables of different networks.
 - 2) In order to have updated information of all available DVB-H signals and networks, the receiver has to execute signal scan on regular basis. Even then, the discovery of other available DVB-H networks succeeds only if the receiver is located on the coverage area of these networks.

The process a) is clearly the most optimal from the receiver point of view. The process b), in turn, always requires a full frequency scan if the discovery of all new DVB-H signals and networks is to be achieved. However, due to lack of NIT_other it still cannot always be guaranteed.

As a conclusion, in a multinet environment where NIT_other is not supported, signal scan may be slow and inaccurate. However, in the "familiar" environment where availability of signals and networks are based on empirical knowledge, the receiver can optimize it by limiting the number of tested signals only to those of existing within the area. Hence, if NIT_other is not supported, this last option would be retained for most receivers as it is easier to implement in existing hardware.

8.5.3 Use of NIT and frequency_list_descriptor

This process is described in detail in clause 4.5.4.1 of the "Guidelines for the implementation and usage of SI" of TR 101 211 [i.3].

The mechanism is based on the tuning on alternative frequencies signalled in the NIT for the current multiplex.

If we consider a receiver moving within the coverage area of one network, the receiver needs to acquire the NIT actual table and in this table the frequency_list_descriptor in order to acquire the frequencies used to broadcast the multiplex.

When the signal strength decreases below a preset threshold, the receiver tests one of the frequencies of the list for the current multiplex, it tries to acquire synchronization on this frequency. Optionally, it checks the time slicing TPS bit for this frequency, avoiding the need to wait for irrelevant information (especially SDT table) (this refinement may be used in the process described in the previous clause). It then acquires the SDT and checks the TS identification. If the desired transport stream is not available it performs a new iteration of the same process. If the desired TS is still not found a different TS with the same SID may be looked for by referring to the NIT actual. This process is rather fast (and may be improved using the probabilistic approach described in clause 8.4.2), as it requires acquisition of a reduced amount of SI information, but broadcasting this information is neither mandatory nor obvious to implement depending on the network topology, even if it does not require any specific network implementation.

In the case when the receiver may move within different networks, the receiver may acquire NIT_other tables in order to complement the alternative frequency list. The receiver is able to check frequencies on other networks; if the desired TS is not available the receiver may check all the TS and test the service_list_descriptor on these TS in order to find the desired service. However, it may be difficult to provide NIT_other tables, especially if the different networks are operated by different operators.

As described in [i.3], this process may lead to tuning failures but may be improved by other means.

The first possibility is local SI insertion leading to identification of each cell as a different network; in such a case the receiver only has to check the frequencies of the neighbouring cells, no longer using the frequency_list_descriptor but the terrestrial_delivery_system_descriptor in the NIT "other" sub-tables. This process is quicker but needs specific network implementation, i.e. insertion of SI on all sites.

A further process relies on the use of two front-ends; this process will not be described according to cost considerations. It looks unrealistic for DVB-H receivers. Moreover, it should be noted that use of frequency_list_descriptor, as described above, does not fit very well for DVB-H. Frequency_list_descriptor indicates frequencies that convey an identical multiplex. However, even if two multiplexes are not mutually identical, they may carry exactly the same set of services. Hence if handover candidates are selected based on such information, a number of valid handover candidates may be ruled out.

Another possibility is the use of cell identification as described below.

8.5.4 Cell identification via TPS and NIT

This mechanism is based on the cell definition and signalling as described in TR 101 211 [i.3] and in EN 300 468 [i.4].

The receiver acquires the cell identification and Time Slicing indicator transmitted in the TPS bits and the cell_frequency_link_descriptor and the cell_list_descriptor transmitted in NIT. It should be noted that when cell_id is provided in the TPS bits, which is always the case for DVB-H, both of these descriptors are transmitted according to TR 101 211 [i.3]. In addition, the DVB-H specification requires the cell list descriptor to be transmitted.

The cell_frequency_link_descriptor provides the frequencies used for the different cells of the network i.e. it provides mapping between frequencies and cells. Furthermore, once the frequencies are mapped with Transport Streams in transport_stream loop, mapping between cell and transport stream can be provided. The cell_list_descriptor provides a description of the coverage area of the cells. In EN 300 468 [i.4], a cell is defined as a geographical area covered by the signals delivering one or more transport streams by means of one or more transmitters. Cell coverage area, in turn, is defined as a rectangle that encloses approximately all of the signal coverage of the signals that are part of that particular cell. Thus, cell coverage area is dependent on the shape of the cell. The shape of the cell, in turn, depends on the transmitters transmitting the signals and on the landscape and environmental effect for the propagation of signals. Figure 8.7 illustrates an example of the cell coverage area definition according to the EN 300 468 [i.4] where the signal is transmitted by one transmitter. Furthermore, table 8.1 describes the parameters presented in figure 8.7.

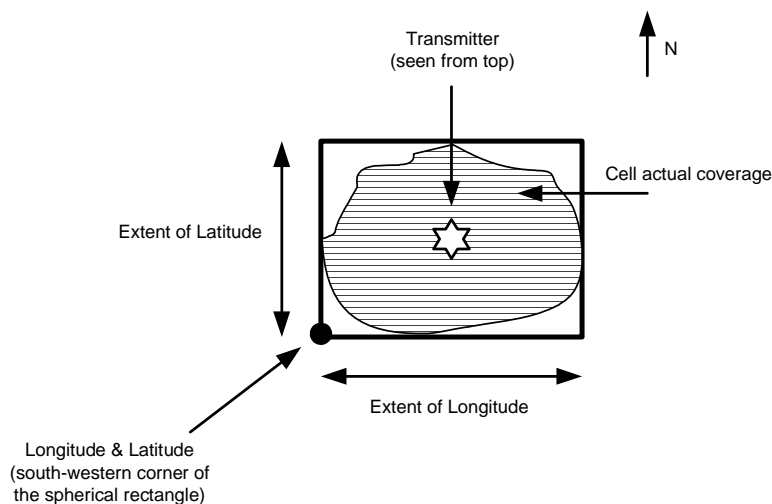

Figure 8.7: Cell coverage area in case of omnidirectional signal as defined in EN 300 468 [i.4]

Table 8.1: Parameters related to cell coverage area

Parameter	Description
Extent of longitude	The extent of longitude of a spherical rectangle describing the approximate coverage area of the cell.
Extent of latitude	The extent of latitude of a spherical rectangle describing the approximate coverage area of the cell.
Longitude	Longitude of the south-western corner of a spherical rectangle describing the approximate coverage area of the cell. Southern latitudes and western longitudes are negative numbers. The numbers are coded as two's complement.
Latitude	Latitude of the south-western corner of a spherical rectangle describing the approximate coverage area of the cell.

The receiver determines the neighbouring cells comparing the locations of the different cells (this process may be helped and improved by use of GPS data if available). However, as figure 8.7 illustrates, only approximate signalling can be provided for the cell coverage area. It should be noted that, it even provides erroneous information as it indicates that some areas beyond the actual cell coverage area signalled as part of the cell. Furthermore, in the current method, there are no means for indicating signal strength levels within the different areas of the cell coverage area. Hence, if cell coverage information is used as the basis for selecting handover candidates it should always be followed with more precise method (e.g. qualification of handover candidates on the basis of signal quality).

This process is rather fast but it requires a specific network implementation, and a specific receiver implementation, the required amount of SI information is larger if NIT other tables are used.

For all the processes described in the previous clauses, the acquisition of the convenient IP stream is done using INT tables.

Note that the frequencies signalled in NIT should include any possible offsets. For example, in case of centre_frequency parameter, the signalling in the related descriptors needs to be updated each time when centre_frequency changes.

8.5.5 Use of INT tables

This process is specific to IP streams carried on DVB-H networks. It may be used to improve the above mechanism in the case of DVB-H services. According to its specificity, this process is further detailed below.

Two IP streams carry the same IP datagram stream if all the following is true:

- Source IP addresses are identical.
- Destination IP addresses are identical.
- IP streams are associated with the same IP platform.
- Destination IP address is not in unicast range, or the IP streams are carried on different transport streams.

Note that unicast IP streams (destination IP address is in unicast address range) in a single transport stream are considered carrying different IP datagram streams. However, unicast IP streams on different transport streams are considered carrying the same IP datagram stream.

If two IP streams carry the same IP datagram streams, a receiver may use any of the IP streams to receive the particular IP datagram stream. A receiver may attempt to accomplish a soft handover between such IP streams.

INT table consist of sub_tables, each for a particular IP platform (identified by platform_id). INT always announces all IP streams on the actual transport stream. To support handover, INT announces all IP streams on the actual cell and on all adjacent/intersecting cells. If INT does not indicate a particular IP service being available on a particular transport stream, a receiver may assume that the IP service is not available on the transport stream. Receiver should check the availability of IP services on adjacent/intersecting cells every time when entering a new cell, as the INT of each cell may not announce IP streams on transport streams that are not adjacent/intercepting with the actual cell.

To announce an IP stream, INT contains one or multiple target descriptors (e.g. target_IPv6_address_descriptor) in a target_descriptor_loop, and one or multiple IP/MAC stream_location_descriptors (one for each IP stream carrying IP datagrams with announced source/destination IP addresses) in the associated operational_descriptor_loop. For more information on usage of INT, see EN 301 192 [i.6].

To enable handover, it is essential that each INT sub_table available on a particular transport stream is announced adding a linkage_descriptor with linkage_type 0x0B into the NIT or BAT carried on the transport stream. If BAT is used, the NIT on the transport stream contains linkage_descriptor with linkage_type 0x0C, announcing the BAT.

To better support reception of Time Sliced services, the INT_versioning_flag in the IP/MAC_notification_info structure carried on the PMT announcing an INT is set to 1, indicating that the PMT announces the version updates of the announced INT.

When receiving a particular IP service, a soft handover may be accomplished using the below described procedure:

- 1) Receiver uses INT on the source transport stream to check for the availability of the IP service (i.e. availability of IP datagram stream(s) carrying the IP service) on other (destination) transport streams. If the INT does not announce the requested service (i.e. all IP datagram streams carrying the IP service) on any other transport stream, soft handover may not be accomplished.
- 2) Receiver checks for availability of the destination transport streams. If none the destination transport streams are available (receiver cannot synchronize to the transport stream), handover may not be accomplished. To check for the availability of a particular transport stream, following procedure may be used:
 - a) Receiver attempts to lock to the frequency announced in the NIT for the requested transport stream. If locking fails, the transport stream is not available. This typically occurs in large terrestrial networks, where different frequencies are used in different areas.
 - b) If lock succeeds, the receiver checks for the Time Slicing indicator from TPS bits. If it indicates that signal carries DVB-H services, next the cell_id is checked. Otherwise signal is discarded and next signal is proceed. If the cell_id announced on TPS bits does not match with the cell_id announced in NIT (on the source transport stream) for the requested transport stream, the signal does not carry the transport stream. This typically occurs in large terrestrial networks, where a particular frequency is used in different areas for different purposes (e.g. two cells may use the same frequency, if the cells are located far from each others).
 - c) If the cell_id matches, receiver assumes that the signal carries the requested transport stream, and the transport stream is available at the current location of the receiver.
- 2) Receiver chooses the destination transport stream supporting the best signal-to-noise ratio, and tunes to the signal carrying the transport stream.

- 3) Receiver uses the `service_id` (announced in the INT on the source transport stream) to find the PMT sub_table, and the `component_tag` (announced in the INT on the source transport stream) to get the PID of the elementary stream carrying the requested IP datagram stream(s).
- 4) Reception of the IP service (i.e. IP datagram stream(s) carrying the service) may continue on the destination transport stream.

Requirements for the receiver

- INT is checked every time when entering a transport stream.

Requirements for the network

- Each transport stream of a cell has identical coverage area (otherwise the described process may fail). Preferably only one transport stream per cell.
- INT announces all IP stream on the actual and on all adjacent/intersecting cells.
- INT is announced by adding `linkage_descriptor` with `linkage_type 0x0B` into the NIT on the actual transport stream. The list of announced INTs is complete (i.e. all INTs of the actual network are announced).
- If the NIT cannot be used for announcing INTs, then the NIT contains `linkage_descriptor` with `linkage_type 0x0C`, announcing BAT on the actual transport stream. The BAT contains `linkage_descriptor` with `linkage_type 0x0B`. The list of announced INTs (in the BAT) is complete (i.e. all INTs of the actual network are announced).
- If a transport stream carries no INT (and therefore no IP streams), the NIT on the particular transport stream should still announce INTs on other transport streams of the actual network. If BATs are used to announce INTs, each NIT of the network should announce each such BAT on the network.

`Cell_id` is mandatory for each cell where DVB-H services are delivered. The `cell_id` has to be announced in TPS bits as well as in the DVB-SI.

The content of the `NIT_actual` is typically quasi-static, but may however sometimes change due to network modifications and/or evolution. A DVB-H capable receiver is therefore able to detect such changes.

The `NIT_actual` needs to contain applicable delivery system descriptors for the actual delivery system. To support re-transmission of multiplexes on different type of delivery systems, the DVB SI specification allows non-applicable delivery system descriptors in the `NIT_actual`. However, when DVB-H services are supported, the `NIT_actual` has to contain the applicable delivery system descriptors for the actual delivery system. Also, the `NIT_actual` announces all multiplexes of the actual delivery system, and it contains one or more `cell_list_descriptors` announcing cells and subcells of the network. The list of announced cells and subcells is necessarily complete.

For each multiplex announced in the `NIT_actual`, `terrestrial_delivery_system_descriptor` and `cell_frequency_link_descriptor` are required to be present. If the multiplex is available on multiple frequencies within the network, the `other_frequency_flag` in the `terrestrial_delivery_system_descriptor` is set. The list of announced frequencies in the `cell_frequency_link_descriptor` has to be complete.

To better support handover between networks supporting DVB-H services, the presence of `NIT_other` for each adjacent network is proposed.

The INT table announces all IP streams on the actual multiplex. To support handover, the INT needs also to announce all IP streams on all adjacent cells of the actual network. In addition, it is proposed that the INT also announces IP streams on adjacent cells on other networks.

It is proposed that the `time_slice_fec_indicator_descriptor` is placed in INT, so that a receiver may detect the support for time slicing on adjacent cells before accomplishing a handover.

Note that a receiver can accomplish handover only if it knows the requested service is available on another multiplex and/or frequency. Therefore it is vitally important that a multiplex announces the content of adjacent multiplexes by means of INT announcing IP streams on adjacent cells, that all frequencies of each multiplex are announced in the `NIT_actual`, and that the geographical locations of each cell is announced in the `NIT_actual`.

This process will be rather fast as the amount of frequencies to test will be reduced, it requires broadcasting of specific SI information (but such information will be mandatory for DVB-H networks) and as such it may require a relatively large amount of SI information.

8.5.6 Time slice synchronization for seamless handover support

When a terminal changes from one DVB-H cell to another, ideally it should be able to seamlessly continue receiving the current service in the new cell without any packet loss, assuming that the service is available in both cells. A cell in this context is a subsystem that may consist of one or several transmitters sending entirely identical content on the same frequency (Single Frequency Network, SFN). Within a cell, no handovers are necessary. When designing the network cells without regard to the phase constellation of the time slices of the corresponding services in adjacent cells, seamless handovers may not be possible.

Assuming that the transmitters of two cells are fed by an IP stream containing a certain service and have their own DVB-H encoders (MPE, time slicing, etc.), IP network delay and packet jitter which may be different for two transmitters of different cells transmitting the same service have to be taken into account. So, if the time slices of the two transmitters will be sent out at the same time, they may contain not exactly the same data and therefore cause packet loss when realizing handovers. This problem is even worsened if the slices of one service in adjacent cells overlap as they can only be decoded in total.

8.5.6.1 Phase shifting

To overcome the previously mentioned problems, a static phase shift between the two cells may be applied ("Phase Shifting"). In this case, the phase shift should be at least the maximum time of the time slice plus the time the terminal needs for synchronization to the new stream. Figure 8.8 illustrates how the overlapping of IP packets (one example marked in grey in the figure) ensures loss-free handovers.

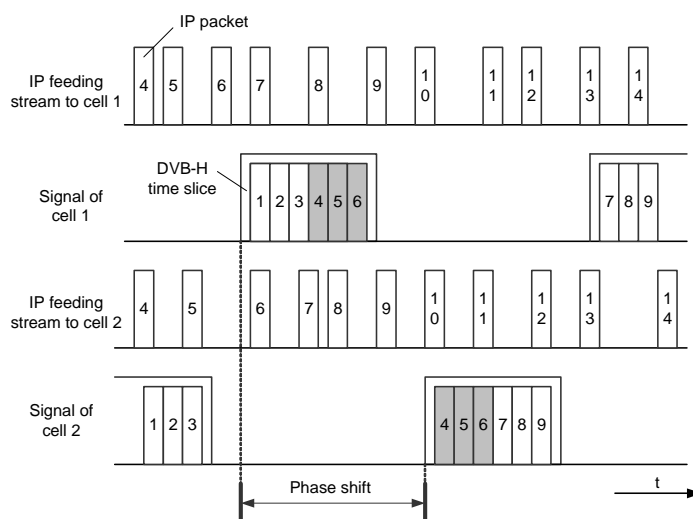

Figure 8.8: Phase shift principle (time axis not to scale)

In real networks, more than two cells have common borders, so more than two different phase shifts are needed. With four different phase shifts loss-free handover between any two cells will be possible, no matter how the shape of the cells might be (mathematical four colour problem). Depending on the cell shape, e.g. with a hexagonal one, it might be possible to use less different phase shifts. The design of a "phase shift map" is very similar to frequency planning in cellular communication networks.

Figure 8.9 illustrates how the time slices of a service have to be phase shifted in four adjacent cells in order to allow seamless handovers. It was taken into account that the terminal needs a synchronization time to tune to the signal of the new cell and starts receiving the corresponding service. Additionally, a safety margin was added in order to deal with possible time slice jitter.

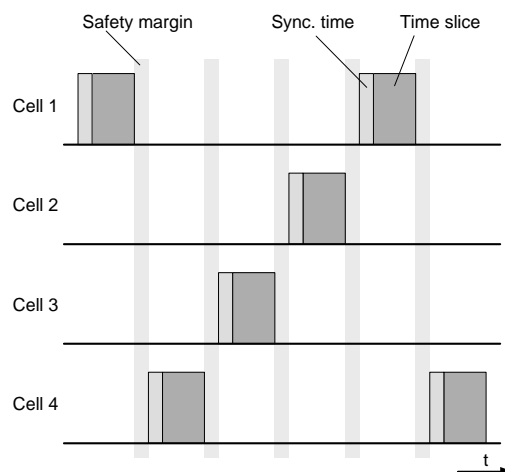

Figure 8.9: Phase shift planning

8.5.6.2 IP Encapsulators synchronization

Another option to fix this issue is to synchronize all the IP Encapsulators in such a way that all transmitted time slice bursts in all the cells have the same content and are transmitted simultaneously.

This kind of solution would remove the requirement of the minimum amount of phase shifting, and it would become possible to choose burst time and cycle time more independently.

NOTE: The description of *how* this synchronization can be implemented is out of scope of the present document.

8.6 Consecutive and parallel transmission schemes of elementary streams and services

This clause discusses consecutive (back to back) and parallel transmission schemes from the perspectives of power consumption, simultaneous reception of multiple services, and physical layer performance.

A consecutive transmission of the Elementary Streams (ES) that carry the main services (Audio/Video channels) enables the receiver to achieve a low power consumption.

Even when the use of consecutive services is the normal DVB-H transmission scheme, the use of parallel transmission may be used in some situations, such as sending ES with short burst-duration in parallel to ES carrying the main services. Parallel transmission is not presented as the main transmission scheme. This clause suggests the option of use the parallel scheme in some cases, and consequently the support of this transmission scheme in the IPE and receivers is needed.

8.6.1 Transmission schemes of elementary streams

Parallel elementary streams and services are just a way of organization of the services in the time / transport stream domain. One simple approach for organization of the DVB-H stream is organizing it in sequential bursts with one elementary stream at a time and with one service per elementary stream as shown in figure 8.10.

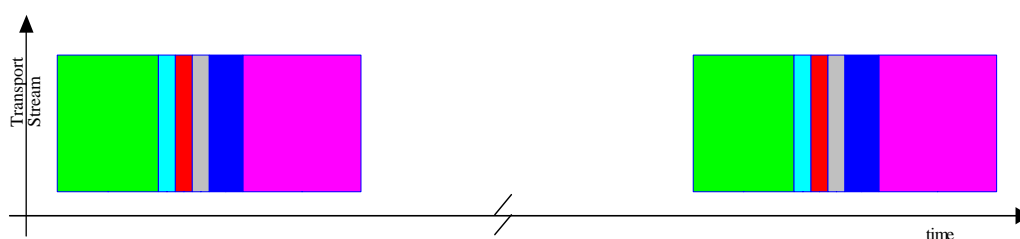

Figure 8.10: Continuous services

Services of different sizes are located one after another within one time slice cycle time. After that the services location in time is repeated. All services have the same maximum (burst) throughput.

Also note that the services may not have all of them the same time slice period. But during this clause we assume that for simplicity.

The same services may however be organized in many other different ways.

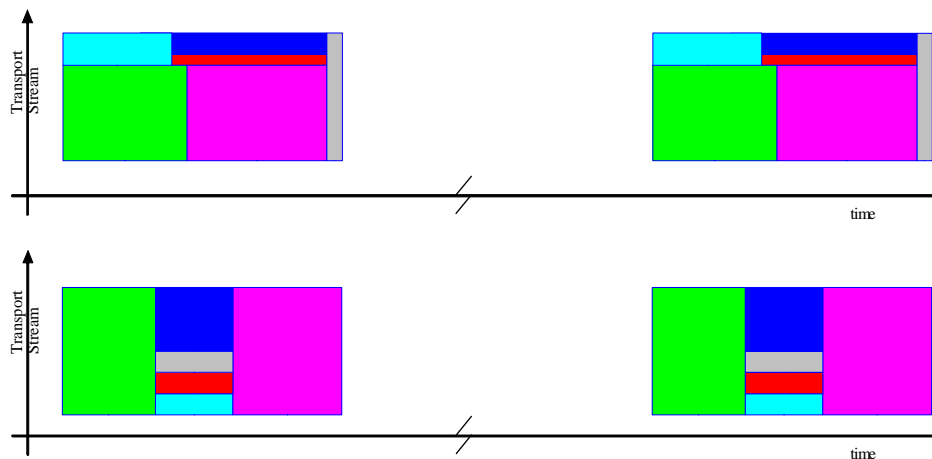

Figure 8.11: Parallel services

Services may be put one in top of the other at the same time in parallel elementary streams or within one elementary stream. The total burst throughput may be exactly the same, the amount of data sent is the same, but the way they are sent is different.

8.6.2 How to set up parallel elementary streams and services?

There are two ways of putting services in parallel:

- In several Elementary Streams.
- In the same Elementary Stream sharing the same PID, but with different multicast address.

8.6.3 Features of consecutive and parallel elementary streams

The following discusses features of consecutive and parallel ES.

8.6.3.1 Power consumption

The consecutive transmission scheme of ES has some power-consumption advantage compared to the parallel scheme.

The power consumption advantage can be demonstrated with the example shown by figure 8.12. In part (a) ES are transmitted in a consecutive scheme, where in (b), groups of three ES are transmitted in parallel.

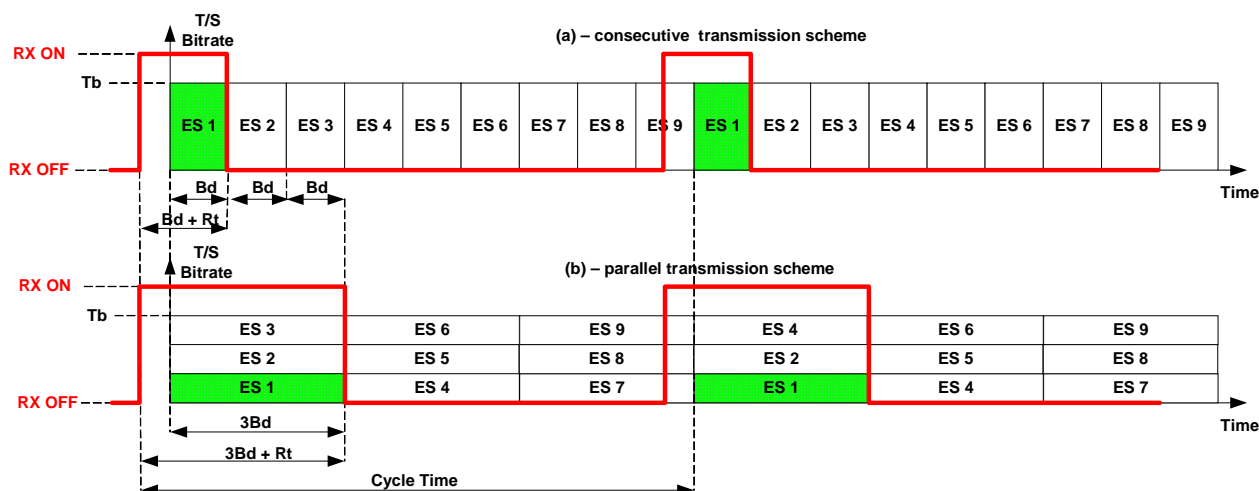

Figure 8.12: The power-consumption advantage of a consecutive transmission scheme

Note that for simplicity, all the ES are shown with the same burst size, but the discussion and the conclusions apply for the general case as well.

- Tb denotes the Transport-Stream bitrate;
- Rt denotes the total time the receiver should be ON before the time-slice begins, in order to re-acquire the time-slice. Rt may be composed of the synchronization time (St) and a fraction of the Delta-t jitter ($3/4 \times Dj$);
- Bd denotes the burst duration of each ES if it would have been transmitted by itself (i.e. w/o any other ES is parallel). $Bd = Bs/Tb$, where Bs is the burst size (the ~4 % overhead of the TS and section headers is neglected here for clarity). When three ES are transmitted in parallel, their burst duration is tripled, and becomes $3xBd$ (as each ES is transmitted with one third of the available TS rate);
- Assume that the user selects the service(s) in ES1 (shown in green). With a consecutive scheme, the receiver's ON time is $Rt + Bd$ in every cycle. With a parallel transmission scheme, the ON time is $Rt + 3xBd$ in every cycle. I.e., with a parallel scheme the receiver has to stay ON for an extra time of $2xBd$ in order to receive the required service(s).

The ON time dominates the power consumption of a DVB-H receiver. Table 8.2 compares the ON time in a consecutive scheme to that of a parallel scheme (with a bundle of two and three ES), and the resulting increase in power consumption. A Rt of 100 ms is assumed (some implementations may even achieve shorter Rt). The comparison is done for three typical TS bitrates (Tb):

- Low TS bitrate: 5,53 Mb/s (QPSK, C/R 1/2, GI 1/8).
- Medium TS bitrate: 11,06 Mb/s (16QAM, C/R 1/2, GI 1/8).
- High TS bitrate: 14,75 Mb/s (16QAM, C/R 2/3, GI 1/8).

Table 8.2: Power consumption increase of a parallel scheme (compared to a consecutive scheme)

Burst size	Low TS rate		Medium TS rate		High TS rate	
	ON Time [ms]	Power Increase	ON Time [ms]	Power Increase	ON Time [ms]	Power Increase
Consecutive Scheme						
0,5 Mb	191	0 %	145	0 %	134	0 %
1 Mb	281	0 %	190	0 %	168	0 %
1,5 Mb	371	0 %	236	0 %	202	0 %
2 Mb	462	0 %	281	0 %	235	0 %
Parallel Scheme: Two ES in parallel						
0,5 Mb	282	48 %	190	31 %	168	25 %
1 Mb	462	64 %	280	47 %	236	40 %
1,5 Mb	642	73 %	372	58 %	304	50 %
2 Mb	824	78 %	462	64 %	370	57 %
Parallel Scheme: Three ES in parallel						
0,5 Mb	373	95 %	235	62 %	202	51 %
1 Mb	643	129 %	370	95 %	304	81 %
1,5 Mb	913	146 %	508	115 %	406	101 %
2 Mb	1 186	157 %	643	129 %	505	115 %

For example, if an ES with burst-size of 1,5 Mb is transmitted with a consecutive scheme in a medium-rate TS scenario, the ON time is 236 ms (= 100 ms + 1,5 Mb/11,06 Mb/s). If two such ES are transmitted in parallel, the ON time becomes 372 ms (= 100 ms + 2 × 1,5 Mb/11,06 Mb/s), which leads to a power consumption increase of 58 %.

For burst-sizes of 1,5 Mb and up the power consumption with two ES in parallel increases by 50 % to 78 % compared to a consecutive scheme. For three ES in parallel the increase is 101 % to 157 %.

8.6.3.2 Fast channel zapping and reception of multiple services

Terminals may choose to receive several elementary streams simultaneously. One of the motivations may be to shorten the channel switch time. E.g., referring to Figure 8.12, assume the user is watching a channel carried in ES2, and that the terminal chooses to receive in addition the channels in ES1 and ES3 (so that if the user chooses to switch to channels in these ES, they will be immediately available). In this example the terminal happened to select the same ES that are bundled by the parallel transmission. But, as the Figure shows, the parallel scheme does not have a power consumption advantage over the consecutive scheme (as the receiver's ON time is R_t+3xB_d in both cases).

The consecutive scheme provides more flexibility in cases where several ES are simultaneously selected by the terminal. E.g., if the terminal chooses to receive ES3 and ES4, the receiver has to stay ON for R_t+6xB_d in the case of the parallel scheme, compared to R_t+2xB_d in the consecutive case.

The terminal may choose to receive several ES simultaneously in other cases as well. For example, the terminal can be receiving ES that carry the A/V content, and in addition it receives ESG updates and/or conditional access information (conveyed by EMM) that are carried in separate elementary streams. The consecutive transmission scheme provides a power-consumption advantage in these cases as well.

To summarize, when the elementary streams are transmitted using a parallel scheme, the decision on which ES to bundle is made at the head-end. This forces a receiver to stay ON for a longer period of time even if it is interested in only few of the ES in the bundle.

When the elementary streams are transmitted in a consecutive scheme, the terminal can decide which ES to select. This provides more flexibility in managing the power-budget at the terminal end.

8.6.3.3 Transmission schemes and physical-layer performance

In general, the physical layer performance may depend on the transmission scheme.

A motivation for using a parallel transmission scheme may be to gain better performance in slow-fading channels (due to the longer transmission time).

Parallel transmission of elementary streams with burst duration (B_d) as low as 150 ms achieves some improvement in slow-fading channels, but on the other hand, results a degraded performance in fast-fading channels.

The main services are typically carried in elementary streams with a large burst size (e.g. 1,5 Mb), and with a burst duration of around 150 ms or more (except for high TS bitrate scenarios where the burst duration can be as short as 100 ms for a burst size of 1,5 Mb). Hence, from the perspective of physical layer performance there is no clear advantage of transmitting ES carrying main services in a parallel scheme.

ES with very short burst duration may be transmitted in parallel to ES carrying the main services, as this may improve their reception in slow fading channels, and on the other hand, the increase in the terminals' power consumption is smaller (compared to the case of parallel transmission of ES with large burst size).

8.6.3.4 Receive low speed services at the same time as main services (ESG update, Alarms, Alerts, Emergencies, etc.)

There are some services like ESG update, alarms, alerts, emergency services, message system, etc., which could benefit from being received in parallel with other services. While a main service is received, other services of smaller size may also be received without switching on again with a different time slicing configuration.

This can be also be accomplished by locating this desired services close in time to the main services, so the receiver should only need to increase the ON time to receive them.

8.6.3.5 Local insertion of services

There may be a business model for local insertion of DVB-H services. In this case, one way to do it is to reserve some percentage of the total throughput to the national services, send this TS to local IPE, and in this local IPE we may add local services on top of the national ones.

8.6.3.6 Optimization of the bitrate

NOTE: In this clause optimization of the bitrate for services sent in different Elementary streams are described in some detail. An equally possible approach is to use several services within one elementary stream or even to combine the approaches.

Parallel services will allow a better optimization of the bandwidth. To explain that we describe, as an example, how 3 services can be organized and how parallel services helps in the bandwidth optimization.

For the example we consider 3 services of different throughputs (378 000 b/s, 256 b/s and 64 000 b/s), the desired MPE-FEC coding rate is 3/4, and we are in a QPSK 1/2. The total TS throughput is of: 4 975 471 b/s. We choose 512 MPE-FEC rows for memory optimization. The result would be:

Constant max Throughput				Calculated values							
	Average Throughput	MFEC CR	Puncturing	Rows	Data Cols	RS Cols	Avg TS Throughput	Max TS Throughput	Burst Data	Burst Length	Frame Period
Service 1	378 000	0,75	100 %	512	191	64	554 400	4 976 471	1 044 480	0,210	1,884
Service 2	256 000	0,75	100 %	512	191	64	375 467	4 976 471	1 044 480	0,210	2,782
Service 3	64 000	0,75	100 %	512	191	64	93 867	4 976 471	1 044 480	0,210	11,127

The average throughput of each service has been increased by the MPE-FEC CR, and added a 10 % of header overhead (this overhead is typically less, but 10 % can be considered as a worst case value).

Due to the fact that the amount of rows and FEC coding are the same for the 3 services, the amount of burst data, and burst length are the same. Finally the Frame periods are really different. On the other hand, a Burst Length of 210 ms is good for the RF and coding performance.

The frame period resulted are good for the first two services, and too long for the third. There is no way to reduce the frame period modifying the amount of rows or the puncturing.

	Average Throughput	MFEC CR	Puncturing	Rows	Data Cols	RS Cols	Avg TS Throughput	Max TS Throughput	Burst Data	Burst Length	Frame Period
Service 3a	64 000	0,75	100 %	256	191	64	93 867	4 976 471	522 240	0,105	5,564
Service 3b	64 000	0,75	50 %	512	96	32	93 867	4 976 471	524 288	0,105	5,585

In 3a we try to reduce the amount of rows, and in 3b we put some puncturing, but in both cases the Burst Length is too low.

If there is a need of having all the services with the same frame period, the resulting configuration would be:

Constant Time Slice period + Constant Max Throughput											
	Avg Throughput	MFEC CR	Puncturing	Rows	Data Cols	RS Cols	Avg TS Throughput	Max Throughput	Burst Data	Burst Length	Frame Period
Service 1	378 000	0,75	100 %	512	191	64	554 400	4 976 471	1 044 480	0,210	1,884
Service 2	256 000	0,75	67 %	512	128	43	375 467	4 976 471	700 416	0,141	1,865
Service 3	64 000	0,75	17 %	512	32	11	93 867	4 976 471	176 128	0,035	1,876

We can do that with puncturing, but it will end up with very low burst length for services two and three.

To overcome this limitation we can put service 2 and 3 one in top of each other, so they are being transmitted in parallel.

Constant burst length											
	Average Throughput	MFEC CR	Puncturing	Rows	Data Cols	RS Cols	Avg TS Throughput	Max TS Throughput	Burst Data	Burst Length	Frame Period
Service 1	378 000	0,75	100 %	512	191	64	554 400	4 976 471	1 044 480	0,210	1,884
Service 2	256 000	0,75	100 %	512	191	64	375 467	4 000 000	1 044 480	0,261	2,782
Service 3	64 000	0,75	24 %	512	46	15	93 867	976 471	249 856	0,256	2,662

If we need to send all the services with the same frame period, a possible solution may be:

Constant Time Slice period + Minimum Burst Length											
	Avg Throughput	MFEC CR	Puncturing	Rows	Data Cols	RS Cols	Avg TS Throughput	Max Throughput	Burst Data	Burst Length	Frame Period
Service 1	378 000	0,75	100 %	512	191	64	554 400	4 976 471	1 044 480	0,210	1,884
Service 2	256 000	0,75	68 %	512	130	43	375 467	3 300 000	708 608	0,215	1,887
Service 3	64 000	0,75	17 %	512	32	11	93 867	838 235	176 128	0,210	1,876
Service 4	64 000	0,75	17 %	512	32	11	93 867	838 235	176 128	0,210	1,876

And there will be enough space to put another low speed service on top of service 2 and 3.

As mentioned above an equally possible approach for bandwidth optimization is to use several services within one elementary stream, this latter case also allows statistical multiplexing of services, which is an important advantage. Finally figure 8.12 shows a graphical example of parallel services.

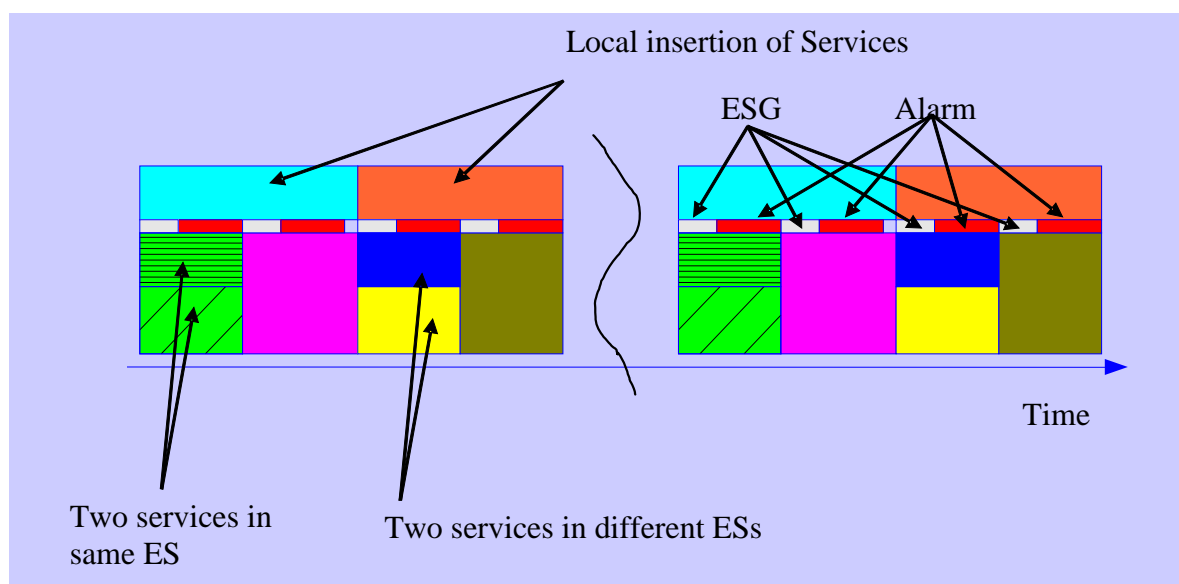

Figure 8.13: Graphical example of parallel services

8.6.4 Elementary streams with multiple services

An elementary stream can carry a single service or multiple services.

For a given burst-size, the transmission scheme of the ES is independent of the number of services it carries. E.g., in figure 8.12, each ES can carry either a single service or multiple services.

Statistical multiplexing is one of the use-cases for multiplexing multiple services in a single ES. Figure 8.14 shows an example: ES 2 has 4 services which are statistically multiplexed (note that the instantaneous bit-rate of each service may change over time), and transmitted in a consecutive scheme with other ES.

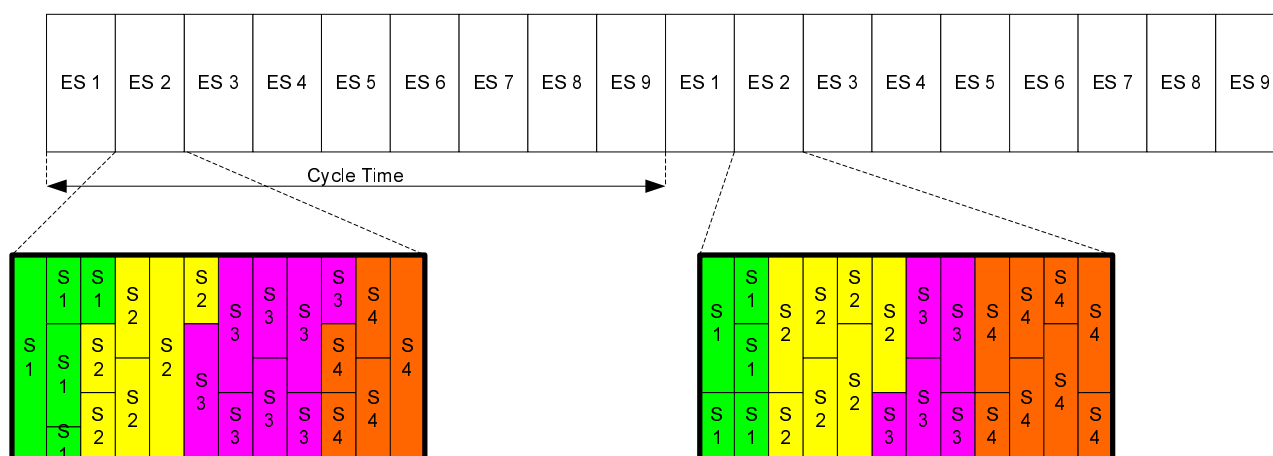

Figure 8.14: Elementary streams with statistically-multiplexed services

An elementary stream with statistically multiplexed services will typically have a large burst size (up to the maximal burst size allowed by DVB-H of 2 Mb). Hence, it may be preferred to transmit such ES in a consecutive scheme.

8.7 Considerations on channel switching

In case the user is receiving an audio/video service on a particular Elementary Stream (ES) and decides to switch to another service, carried on another ES within the same Transport Stream, there is some inevitable delay before the new service can be presented for the user.

Fundamentally this delay is determined by two main components:

- Delay before the IP datagrams of the new ES are available for further processing. The fundamental parameter is here the time slice cycle time. When the user selects a new service the receiver has to wait for the new burst, see worst case example in figure 8.15.
- Delay before the new audio/video service being carried by the IP datagrams can be presented to the user. The fundamental parameter here is the Group of Pictures (GOP) length of the video, i.e. the repetition period of the Intra-coded frames (I-frames) carrying only information from the frame itself. The receiver cannot display anything until it has received the first I-frame of the new service.

QPSK DVB-H – 10 Video Streams (one stream per time slice)

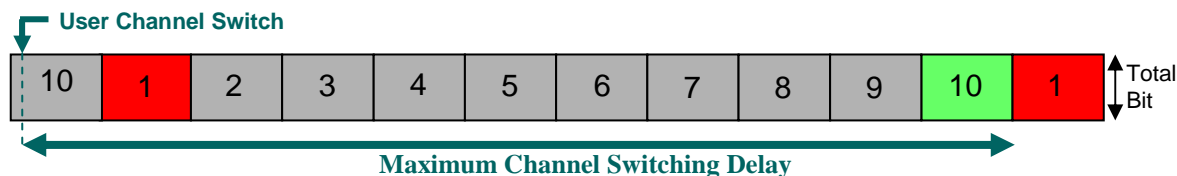

Figure 8.15: Example of worst case zapping delay

Typical time slice cycle times is likely to be found in the range 1 s to 2,5 s (see clause C.2).

If the audio/video content is synchronized with the time slice structure in such a way that each received time slice burst contains exactly an integer number of GOPs, this allows the receiver to start decoding of the audio/video immediately after a burst has been received and MPE-FEC decoded. The MPE-FEC decoding is likely to take about 0,1 s.

Furthermore, if the buffer size of the video player is adjusted to equal the time slice cycle time (or a smaller value) this means that once a burst has been received (and MPE-FEC decoded) there is no fundamental further (significant) delay required before the audio/video can be decoded/displayed, because the full GOP is already available and the buffer is filled.

The *best case scenario* for fast channel switching time, given the above assumptions, should then be when the zapping decision takes place immediately *before* the new burst begins. The corresponding zapping delay is then fundamentally limited by the burst length plus the MPE-FEC decoding, i.e. in the order of 0,3 s (using DVB-H parameter sets 2 and 3 in clause C.2).

The corresponding *worst case scenario*, again given the above assumptions, is when the zapping decision is made immediately *after* the start of the new burst, assuming that there is only one GOP in the burst and that the I-frame is missed. In this case the receiver has to wait a full time slice cycle time plus the burst duration plus 0,1 s for MPE-FEC decoding before it can start the decoding of the video. With a time slice cycle time of 1,6 s and a burst length of 0,2 s (again using DVB-H parameter sets 2 & 3 in Annex C.2) it would therefore take 1,9 s before the new burst has both been received and MPE-FEC decoded and therefore available for immediate decoding/display.

The channel switching time would therefore lie in the range 0,3 s to 1,9 s with an average value of 1,1 s (0,3 plus 1,9 divided by 2). With a shorter cycle time this value could even be further reduced. It could therefore be said that with a properly set-up system it should be possible to have a typical/average channel switching time in the order of one second or lower, without compromising power saving or other time slicing features.

If the GOP structure of the video is non-synchronized with the time slicing the average channel switching time will of course be somewhat longer. If the GOP length equals the cycle time the channel switching time will in principle be doubled. If the GOP length is significantly smaller than a cycle time the channel switching time will however only be marginally affected.

Finally, if the video player requires a larger buffer than what is contained in a time slice burst, the channel switching time will increase with (at least) one cycle time. However, a properly designed system and receiver should not require this.

8.8 The Dynamic Zapping Service

8.8.1 Introduction

The dynamic zapping service is an optional service, which is associated with a streamed DVB-H service. The main purpose of a dynamic zapping service is to give the user quickly an impression about the current content of the associated DVB-H service.

The dynamic zapping service can carry different types of content such as a current snap shot, video or sound with reduced quality and data rate, or sub-titles from its related DVB-H service. A DVB-H service and its related dynamic zapping service are transmitted as different elementary streams within the same transport stream. The dynamic zapping service uses the same protocol stack as a streamed DVB-H service.

To achieve a quick access to the dynamic zapping service, the burst cycle time is significantly shorter than the burst cycle time of the related DVB-H service. Content from several different dynamic zapping services, complementing different DVB-H services, may be collected within the same burst. The content of a dynamic zapping service may be updated burst-wise to track the progress in the content of the DVB-H service.

8.8.2 Two use cases

In a first use case, the user selects a DVB-H service on his terminal. The terminal may wait to receive this DVB-H service and its complementing dynamic zapping service in parallel. Due to its shorter burst cycle time, the burst with the dynamic zapping service may be received, processed and presented earlier. Thus, the user quickly gets an impression on the progress of the selected DVB-H service.

In a second use case, the user may want to get a quick impression on the content and progress of many services. Thus, all dynamic zapping services from the recently received burst are processed. Their contents can be presented to the user in several ways.

8.8.3 Generation of the dynamic zapping service

The dynamic zapping service can be generated in several ways. In a typical case, the content of the DVB-H service is decoded in real-time at the head end. Then, single pictures ("snap shots"), video or sound are re-encoded, embedded in IP and sent to the MPE encapsulator.

8.8.4 MPE encapsulation and multiplexing

The zapping burst cycle time is shorter than the burst cycle time of the normal DVB-H services. All zapping streams, which are received by the MPE encapsulator during one zapping burst cycle time, are collected in one burst. The zapping streams are differentiated by their IP addresses. For the terminal, the reception of one single burst is sufficient to satisfy the use cases described above.

Figure 8.16 illustrates one example of timely order of bursts: The MPE encapsulator inserts a burst, which carries the dynamic zapping services 1 to 5, between two bursts, which carry the normal DVB-H services.

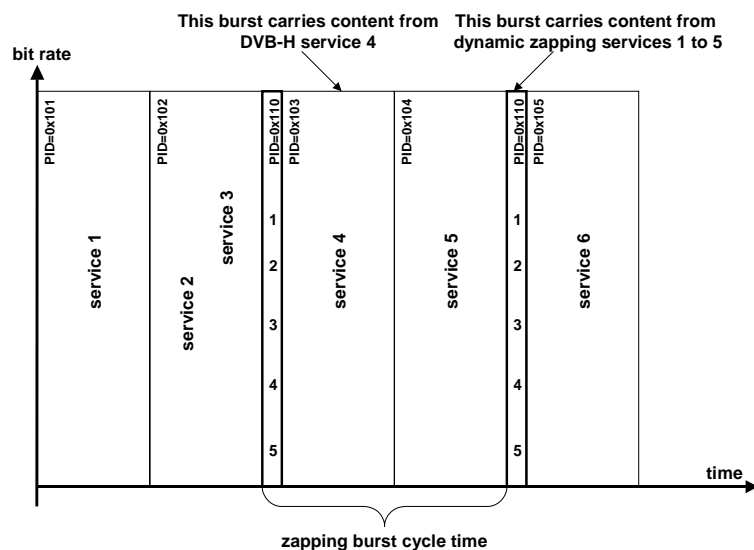

Figure 8.16: Example for carriage of dynamic zapping services 1 to 5 in bursts

Figure 8.17 illustrates another example of timely order of bursts: Dynamic zapping services are transported in parallel to normal DVB-H services. Most of the bit rate is dedicated for the six normal DVB-H services, and the rest of the bit rate is used by services such as alarm, ESG updates and dynamic zapping.

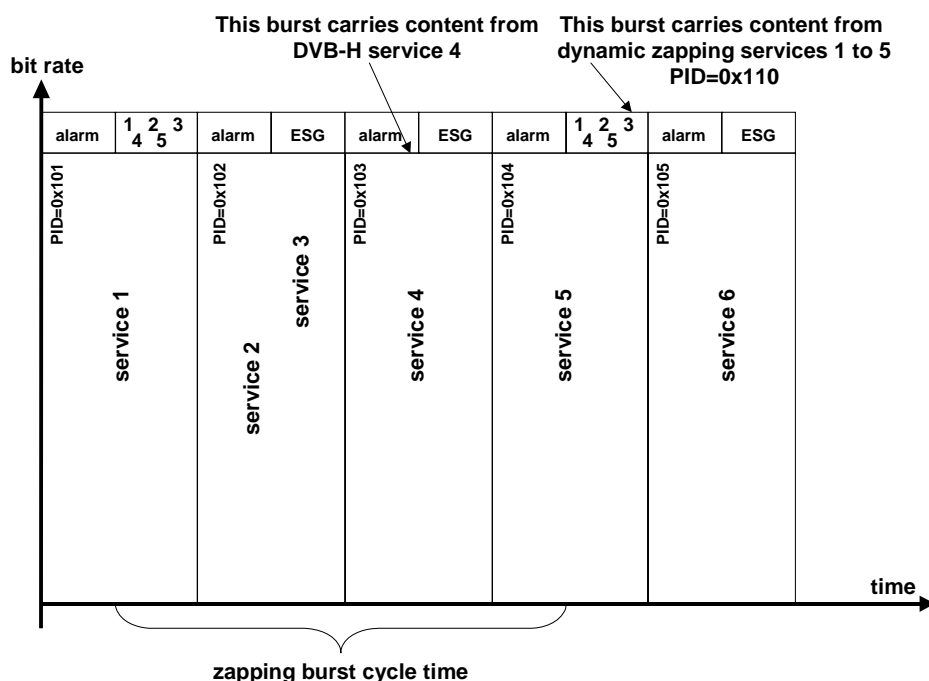

Figure 8.17: Example of parallel services

8.8.5 PSI/SI considerations

Similar to normal DVB-H services, the INT maps the IP addresses of the dynamic zapping services to their transport stream location, i.e. to their PID.

8.8.6 Terminal behaviour examples

According to the first use case, the terminal discovers the availability of a dynamic zapping service from the ESG and its PID from the INT. When the user selects a DVB-H service, the terminal may wait to receive this DVB-H service and its complementing dynamic zapping service in parallel. As an implementation example, a first PID filter would filter the selected stream from the received transport stream, and a second PID filter would filter the dynamic zapping stream. An IP address filter would extract the relevant dynamic zapping IP datagrams. These IP datagrams are then decoded in the usual way. The content of this one dynamic zapping service, such as a snap shot and associated mono sound, can be presented on the screen and through speakers.

If, as described in the second use case, the user wants to get a quick impression on the progress of all services currently on-air, then solely the burst carrying the dynamic zapping services is received and processed. One PID filter is sufficient in such a use case. The content of several or all dynamic zapping services is decoded and can be presented on the screen and through speakers.

8.8.7 Bit rate calculations

The additional bit rates, introduced by the still picture type and the audio type zapping service, are calculated below. In the three calculations, a typical H.264/AVC video service of level 1.2, targeted to terminals of capability class B, such as mobile phones, is assumed as reference, see table 8.2.

Table 8.2: Parameters of a given video service

video parameter	value
resolution	352 × 288 pixels (CIF)
frame rate	15 frames/sec
bit rate	384 kb/s

A still picture type zapping service, which provides a good visual quality on a terminal of capability class B, may have the following parameters as shown in table 8.3.

Table 8.3: Typical parameters of a still picture

picture parameter	value
resolution	176 × 144 pixels (QCIF)
codec	JPEG
colour depth	24 bit
upper limit for picture size	24 kbit
picture rate	1 picture/sec
maximum bit rate	24 kb/s

Given the video service and the zapping service have the same MPE-FEC code rate, then they are expected to have about the same percentage of overhead. In this case, the additional bit rate introduced by the dynamic zapping service is 24 kb/s per 384 kb/s, respectively 6,25 %.

A still picture type zapping service, which provides the same picture resolution as the video service, may have the following parameters as shown in table 8.4.

Table 8.4: Typical parameters of a still picture

picture parameter	value
resolution	352 × 288 pixels (CIF)
codec	JPEG
colour depth	24 bit
upper limit for picture size	80 kbit
picture rate	1 picture/s
maximum bit rate	80 kb/s

Given the video service and the zapping service have the same MPE-FEC code rate, then they are expected to have about the same percentage of overhead. In this case, the additional bit rate introduced by the dynamic zapping service is 80 kb/s per 384 kb/s, respectively 21 %.

An audio type zapping service, which provides sufficient sound quality, may have the following parameters as shown in table 8.5.

Table 8.5: Typical parameters of an audio stream

sound parameter	value
channels	1
bit rate	16 kb/s

In this case, the additional bit rate introduced by the dynamic zapping service is 16 kb/s per 384 kb/s, respectively 4,2 %.

9 DVB-H networks

9.1 Considerations on Network configuration

9.1.1 Introduction

As mentioned in the document, DVB-H arises, basically, from two needs: the first is to save power on the receiver side, which is basically solved with time slicing, and the second is to have a more robust signal that would allow the deployment of cost efficient networks providing service to receivers in conditions similar to the ones of mobile cellular telephony, meaning indoor handheld reception at very-low or no speed, and outdoor handheld reception at high or very high speed.

For this second need, DVB-H foresees two mechanisms: selection of the appropriate DVB-H/T mode and parameters (from now on referred as DVB-H mode and parameters) on which the standard is based, and the use of an extra protection in the Link layer by means of MPE-FEC. This clause provides guidelines about those recommended modes and parameters.

9.1.2 DVB-H FFT modes

9.1.2.1 Indoor handheld reception (at no speed)

The indoor handheld reception is not restricted by speed; the only restrictions are the effects of multipath (high C/N needed in a Rayleigh channel) and impulse noise. This second effect leads to the selection of a longer symbol mode, the **8K mode**, which is more robust than the 2K, or at least the use of **in-depth interleavers**, such as the use of a 4K mode in an 8K interleaver or even 2K mode in an 8K interleaver.

SFNs offer the most spectrally efficient network architectures. If we start with the theoretical radius of each SFN cell in a 2K SFN for a given guard interval, then the radius for 4K and 8K based networks is, respectively, 2 and 4 times larger than that of the 2K network. Table 6.2 illustrates for each mode and chosen guard interval, the guard interval duration, that will determine the radius of an SFN cell. In any case, the selection of an 8K mode or 4K mode provides the added benefit of allowing SFN topologies.

9.1.2.2 Outdoor handheld reception (moderate to high speed)

Outdoor handheld reception is restricted by speed, multipath (high C/N needed in a Rayleigh channel), and impulse noise. Depending on the maximum speed at which we would like our service to be receivable, the selection of the proper DVB-H mode becomes crucial to the operation of the service.

The current DVB-T standard provides excellent mobile performance with 2K modes, but with 8K modes the performance is unsatisfactory, especially with reasonable receiver cost/complexity. On the other hand, on the network planning side, the 2K mode is marginal mainly due to the short guard interval, which effectively prevents its usage in the allotment type of planning, where rather large geographical areas are covered with one frequency, i.e. Single Frequency Networks (SFN). For these reasons a compromise 4K mode would allow acceptable mobile performance with reasonable receiver costs, while allowing the use of more economical and flexible network architectures.

It can be estimated that the mobile performance in Typical Urban channel conditions with 8K is 65 km/h for CR = 2/3, and 86 km/h for CR = 1/2, at 500 MHz with $T_g = 1/4$. These speeds were achieved with the *Motivate* reference receiver. The *Motivate* receiver, which produced this performance, employed a moderate complexity channel estimator significantly better than most current DVB-T demodulators targeted for fixed reception. The reduced sub-carrier spacing in the 8K mode results in higher sensitivity of the demodulator to ICI that arises from Doppler spread in a mobile channel. Better performance is possible in 8K mode if more advanced channel estimation and ICI-cancellation techniques are applied. However, these techniques add considerable cost, complexity, and power consumption to the demodulator, a problem for hand portable receivers. The 4K mode with double the sub-carrier spacing of the 8K mode provides roughly 2 times better Doppler performance than 8K. By using this rule and doing linear interpolation between the known 2K and 8K performance figures of the *Motivate* reference receiver, the performance of the 4K in a mobile environment can be predicted as in table 6.1.

However, it should be noticed that mobile reception in 8K mode is limited by C/N, not by the theoretical limit (related to Doppler Effect). Using MPE FEC and selecting the proper DVB-H physical layer parameters, the use of the 8K mode is feasible at speeds lower than 120 km/h in UHF band IV and V frequency bands. (Please notice that the higher the frequency the less speed is reached.) This would provide an excellent behaviour against impulse noise and the capability of building large SFNs.

Nonetheless, for higher speeds services (e.g. high speed trains at 300 Km/h) the use of a 4K or 2K mode is required. The same applies when the service would require higher bitrates, i.e. less redundancy, less protection, but, in this case, the 4K mode would be the best since it is more robust against impulse noise than the 2K one. The trade off is the difficulty to build large SFN networks economically.

Possible future services at other frequency bands (higher) would require a 2K mode to provide a mobile service.

9.1.3 DVB-H parameters

9.1.3.1 Physical layer parameters

For mobile and portable reception, the most usable modulation scheme is 16-QAM with code rate of 1/2 or 2/3 requiring a moderate C/N, while also providing enough capacity to meet commercial requirements:

- Constellation: QPSK, 16-QAM and eventually, although not recommended, 64-QAM.
- FEC: 1/2 and 2/3 (the mode 1/2 of the higher constellation provides the same bitrate but presents a better C/N in Rayleigh channel than the 3/4, e.g. 16-QAM 1/2 is better than QPSK 3/4).
- G.I.: Depending on network topology, the same ones as in DVB-T. The recommended G.I for SFN are:
 - for 2K: 1/4,
 - for 4K: 1/4, 1/8, and
 - for 8K: 1/4, 1/8.

9.1.3.2 Link layer parameters

9.1.3.2.1 Introduction

Link layer parameters, in particular MPE-FEC parameters, are of extreme importance in DVB-H networks because the actual coverage depends on the extra FEC added at this layer. For example, without MPE-FEC it could be difficult/costly to build 8K SFN networks for mobile reception. On the other hand, it should be borne in mind that a trade off is necessary between the available bitrate and the extra robustness required for the service that uses MPE-FEC.

Service access time is seen as a crucial parameter for the DVB-H usability. Especially zapping between different services "channels" needs to be as fast as possible. Early user trials have shown that zapping times between 1,5 s and 3 s are considered acceptable.

This means that the length of the time slicing OFF period should be minimized. The phase shift concept (to allow seamless handover to another TS) also puts some limits to the minimum length of the OFF period.

The second important parameter is power consumption. The average power consumption should be low enough. The average power consumption is a trade off with channel zapping time. The optimum trade off point is achieved when the average power consumption is just below the defined threshold and the OFF period length is minimized.

The average power consumption should be low enough to give long enough usage time. The limit set for the average power consumption, 100 mW, was derived in the DVB-H group from the DVB-H commercial requirements. The 100 mW limit can also be justified from the entire terminal power consumption point of view. If the DVB-H average power consumption is <100 mW it will be typically less than 10 % of the entire terminal power consumption.

In addition to this there are also some other important parameters to consider:

- Average bitrate of the Elementary Stream (ES): a higher value will allow more services per ES and may allow:
 - fast zapping between services within the same ES,
 - statistical multiplexing of video (or audio) services within the same ES (in a similar way as a regular DTT multiplex),
 - more flexibility in terms of service bitrate.
- Burst time/interleaving time: affects the RF performance.
- Size of MPE-FEC frame: affects RF performance (for a given interleaving depth).

The main input parameters for the DVB-H parameter selection process from the receiver point of view are:

- Receiver synchronization time.
- Power consumption values, active-state and off-state.

The parameters are described in more detail in subsequent clauses. Also typical values for state-of-the-art implementations are given.

9.1.3.2.2 Receiver synchronization time

The receiver synchronization time is different for different use cases. The synchronization time can be shortened if the DVB-H parameters are known beforehand. The initial synchronization without knowing the exact centre frequency in case offsets are used and DVB-H parameters can be much longer. However during time sliced reception the centre frequency and DVB-H parameters remain the same. Therefore for the average power consumption calculation the shortest synchronization time should be used.

The receiver synchronization time can be divided into several phases. First the RF synthesizer (PLL) stabilizes. Secondly the automatic gain control has to get stabilized enough before the COFDM synchronization can start. The different phases are depicted in figure 9.1.

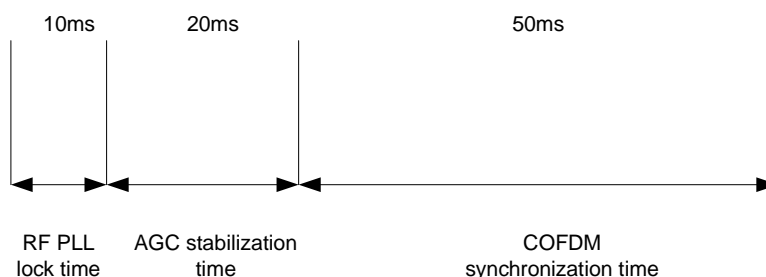

Figure 9.1: Receiver synchronization phases

The COFDM synchronization was in the range of 200 ms to 300 ms in DVB-T set-top-box implementations. There the synchronization strategy was based on first acquiring pre-FFT synch & post-FFT synch and then TPS lock. In total the synchronization required at least 100 OFDM symbols, which is 100 ms in 8K system. However, much faster synchronization schemes have been presented in various conferences. In the fast schemes the number of required OFDM symbols for synchronization is less than 15, which is 15 ms in 8K system. In 2K and 4K systems the synchronization times are faster. Typical state-of-the art values for the synchronization are presented below. These figures are however quite pessimistic and in practical implementations the synchronization could be even faster:

- RF PLL stabilization 10 ms.
- AGC stabilization 20 ms.
- COFDM synchronization 50 ms (8K system). *In difficult SFN networks with 1/4 guard interval the synchronization time might be slightly longer, i.e. 80 ms to 90 ms.*

The total synchronization time is therefore typically less than 80 ms (< 120 ms with 1/4 GI).

9.1.3.2.3 Power consumption figures

The DVB-H receiver usually has five power modes. These are RF_ON mode, RF_OFF1 mode, RF_OFF2 mode, RF_OFF3 mode and Sleep mode. The modes are described in table 9.1. System power management is usually optimized so that only needed modules are refreshed or powered.

Table 9.1: DVB-H Power modes

Power mode	Description
RF_ON	The RF part is active and DVB-H demodulation is active. The wanted time slicing burst is received.
RF_OFF1	The RF part is shut down. MPE-FEC calculation is ongoing. IP packets with no errors can be forwarded before MPE-FEC calculation is finalized.
RF_OFF2	The MPE-FEC calculation is finished. DVB-H receiver is feeding data for application engine.
RF_OFF3	The data transfer to application engine is finished; DVB-H receiver is waiting for the next burst.
SLEEP	DVB-H application is not used. The DVB-H receiver is in sleep mode waiting for the wake command.

Figure 9.2 presents the timing related to the power modes.

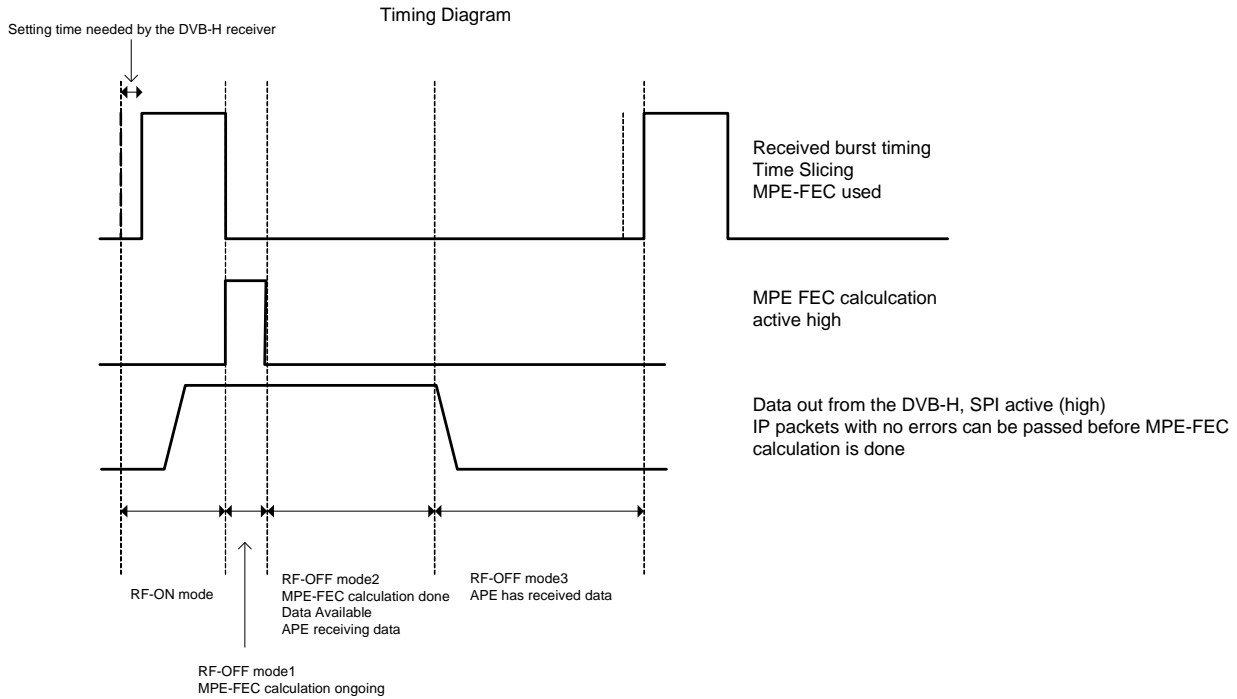

Figure 9.2: Receiver synchronization phases

For the time slicing calculations RF_OFF1 and RF_OFF2 can be combined. Let us call the combined value RF_OFF1.

The typical state-of-the-art values for the parameters are presented below. The RF is based on direct conversion silicon tuner. The baseband IC technology is 90 nm. These can be considered typical for 2006 and onwards implementations.

- RF_ON 400 mW (200 mW RF part and 200 mW BB part).
- RF_OFF1 50 mW (RF OFF and data buffering ongoing).
- RF_OFF3 10 mW (Waiting for next burst).

9.1.3.2.4 Time slicing period & MPE-FEC burst size equations

The time slicing period has major effect on service access time in channel zapping case. From usability point of view the length of the OFF-period should be as short as possible. Average power consumption target & possible usage of phase shift in networks sets limits for the shortest possible OFF-period length.

The time definitions are presented in figure 9.3.

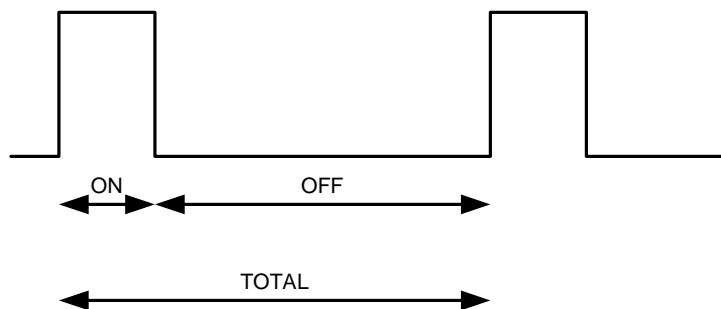

Figure 9.3: Time slicing time definitions

Time slicing period is set directly by burst size and Elementary Stream bitrate called ESstreambitrate here:

$$TOTAL = \frac{burstsize}{ESstreambitrate} \quad (1)$$

The ON period is set by burst size and burst rate, the locktime adds overhead:

$$ON = \frac{burstsize}{burstrate} + locktime \quad (2)$$

The OFF period is therefore:

$$OFF = \frac{burstsize}{ESstreambitrate} - \left(\frac{burstsize}{burstrate} + locktime \right) \quad (3)$$

The burst size in case MPE-FEC is used is set directly by number of rows. With MPE-FEC coderate $\frac{3}{4}$ (i.e. 255 columns) the following burst sizes are achieved:

- 256 Rows = 512 kb.
- 512 Rows = 1 024 kb = 1 Mb.
- 768 Rows = 1 536 kb.
- 1 024 Rows = 2 048 kb = 2 Mb.

Annex C contains some examples of link layer parameter selection for DVB-H networks.

9.2 Dedicated DVB-H networks

A dedicated DVB-H network is one in which DVB-H services do not share the TS multiplex with existing DVB-T services. The full multiplex is, therefore, dedicated to carrying only DVB-H services. For such networks, the changes to DVB-T network elements are mainly:

- *Head-end*: The current multiplexers are ready to incorporate DVB-H services. The only new element needed is the so-called "**DVB-H codec**", which is the evolution of the IP encapsulator including MPE-FEC and time slicing. SFN adapters need also to be upgraded to include the signalling of the new transmission parameters in the MIP packet.
- *Modulators*: The current DVB-T modulators are ready to support DVB-H services by upgrading the **TPS insertion** to support DVB-H TPS signalling as described in clause 6.3.

However, if the DVB-H services would require the use of 4K (or in-depth symbol interleaver for 2K/4K), then the following changes to DVB-T modulators would be required:

- 1) Changes in symbol (inner) interleaver to incorporate 8K interleaving for 2K and 4K network operation.
- 2) Changes in IFFT to support 4K mode.

9.3 Service Information issues

The MPE-FEC provides a very large performance gain for transport of IP datagrams over DVB-H. However, the Service Information (SI), is not protected by the MPE-FEC.

In general, some parts of the SI are typically quite static, whereas other parts vary dynamically. The role of SI is, however, quite different with IP Datacast DVB-H services than with DTT services. In DTT, the Event Information Table (EIT) of the SI dynamically signals, for example which program content is being broadcast. This will not be the case with IPDC/DVB-H, where this kind of information is signalled via the Electronic Service Guide (ESG), which is sent over IP and is, therefore, MPE-FEC protected. The robustness of this dynamic information will not be further addressed in this clause.

The main PSI/SI needed by an IPDC/DVB-H terminal are:

- **NIT** Network Information Table.
- **INT** IP/MAC Notification Table.
- **PAT** Program Association Table
- **PMT** Program Map Table.

Concerning PAT/PMT, the size of the respective tables and the repetition rate (10 times per second) are such that robustness is not a problem at a TS PER of 10 %, or even higher.

The role of SI in IPDC/DVB-H is more restricted and is mainly to provide the receiver with information on how to access a certain IP address. The basic mechanism is the following: In the ESG the receiver can read that a particular service is available on a certain IP address at a certain day/time. In order to determine on which frequency and on which PID etc. the IP address is available, the receiver uses the PSI/SI to get the right mapping between IP address and bearer specific parameters.

The INT provides the mapping from IP address to physical parameters like TS id, service id, etc., and the NIT provides information about the network and on how to access a certain TS (cell_id, frequency, mode etc). The information sent in the INT and the NIT can, therefore, in principle, be rather static. Even if the *content* of a certain IP address is changing, the INT does not have to change. As mentioned above, the change of content is MPE-FEC protected and signalled in the ESG.

So, the conclusion is that the NIT and INT tables could be quasi-static and the receiver does not have to actually receive them each time it is switched on or each time it performs handover, provided the tables are stored in the receiver.

Case 1: SI tables do not depend on geographical location within a country.

If the NIT and INT are defined to cover, for example, a full country, they could be stored in the receiver and updated only when they have changed. Any change of content of the NIT and/or INT would then be signalled in the PMT so a DVB-H receiver would immediately be aware of this and could start downloading the updated tables. Robustness will not be a problem in this case.

Case 2: SI tables do depend on geographical location within a country.

If the SI tables differ between different areas of the network, it may be necessary to actually receive these tables more frequently, unless they are already stored.

If one can assume that the receiver accesses the SI each time it is switched on and in connection with each handover, then this SI has to be receivable in a robust way without too much delay (preferably before the next burst). Due to the fact that the SI is tailor-made for the specific area, the size of the SI tables can be made highly limited in size. It is then possible to repeat the tables much more frequently than the required minimum (every 10 s for NIT and every 30 s for INT). If the table sizes are small, they could be repeated, e.g. every second, and the probability of correct reception would increase dramatically thanks to the redundancy provided by the repetitions.

With a section size of 1 kByte, a section error probability of 0,1, and a table size of 16 kByte repeated each second, the overhead for the table would be 131 Kb/s, and the probability of receiving the full table correctly would be the following:

after 1 s: > 18 %

after 2 s: > 85 % $(1 - 0,1^2)^{16}$

after 3 s: > 98 % $(1 - 0,1^3)^{16}$

after 4 s: > 99,8 % $(1 - 0,1^4)^{16}$

So, after 2 s or more, the probability of correct reception of the table is larger than 85 % in this example. What is important to note is that when effective MPE-FEC decoding is possible, the TS PER is such that also correct SI reception is guaranteed after a limited number of repetition cycles.

In connection with handover or scanning other frequencies it should, thus, in many or most cases be possible to access the SI in a robust way before the next burst arrives, provided the burst cycle time is more than, for example, 3 s.

With section error probability = 0,3 one can still receive the full table correctly with 88 % probability after 4 s (98,8 % after 6 s).

Note that correctly received sections can be stored, and tables consisting of multiple sections can be gradually filled, after several reception cycles. If, for example, a table consists of 10 sections, and the section error probability is 10 %, then, on average, there will be 9 correctly received sections in the first attempt. These will be stored. In the next reception cycle there is a 90 % probability that the remaining section will be correctly received. If we are unlucky we have to wait one more reception cycle after which we again have a 90 % probability to receive it correctly (and so on).

The probability of having received a particular section, with section error probability $p_{e_section}$, fully correctly after N cycles is: $1 - p_{e_section}^N$.

The corresponding probability p_{e_table} of **not** having received a table, consisting of M sections, fully correct after N cycles, can be calculated as:

$$p_{e_table} = 1 - \left(1 - p_{e_section}^N\right)^M \quad (4)$$

As can be calculated, in most cases, very robust reception of SI tables can be obtained after just a few seconds, even in extremely bad channel conditions.

For example, with an SER (Section Error Ratio) of 0,3 (corresponding to PER = 0,15 for 4 096 byte sections) and 3 sections per table, correct reception after 4 s can be expected with more than 98 % probability. (After 10 s there is only one chance in 10^5 to miss the table).

In conclusion, the PSI/SI to be used for DVB-H will most probably be quasi-static, since all content related information is sent over IP. This information can, therefore, in principle, be stored in the receiver, which will make access much less time critical. By the redundancy of the repetition of the PS/SI tables, correct reception is guaranteed, sooner or later in all reception conditions where MPE-FEC decoding is effective. In cases where fast access of SI, not previously stored, is required, this can be accomplished by increasing the repetition rate of the NIT and INT. With a repetition rate of, for example, one second, correct reception of SI tables can be obtained within a few seconds, also in very bad channel conditions.

9.4 Considerations on the use of repeaters in DVB-H networks

This clause contains guidelines and recommendations for the use of repeaters in DVB-H networks.

9.4.1 On-channel repeaters

An on-channel DVB-H repeater, also known as gap-filler, is a device which receives a terrestrial DVB-H emission at a certain VHF/UHF frequency, amplifies the received channel, and retransmits it in the same frequency. Such a repeater is used to extend the coverage of an existing DVB-H network through emissions at a single frequency without the need for additional transmitters. The main benefits of repeaters, when compared to ordinary transmitters, are easier deployment and lower cost.

The delay induced by the whole process of reception, amplification and transmission needs to be substantially shorter than the guard interval of the used DVB-H mode (a typical delay is 5 μ s), so that a receiver receiving both signal from a transmitter and signal from a repeater does not have to deal with interference but with a constructive addition of signals.

The main obstacle in the deployment of repeaters is a problem inherent to its logic. The transmitted signal may be fed back to the input of the repeaters, thus creating a feedback-loop, which generates two kinds of problems: ripple in the transfer function of the device, and, at worst, instability of the device.

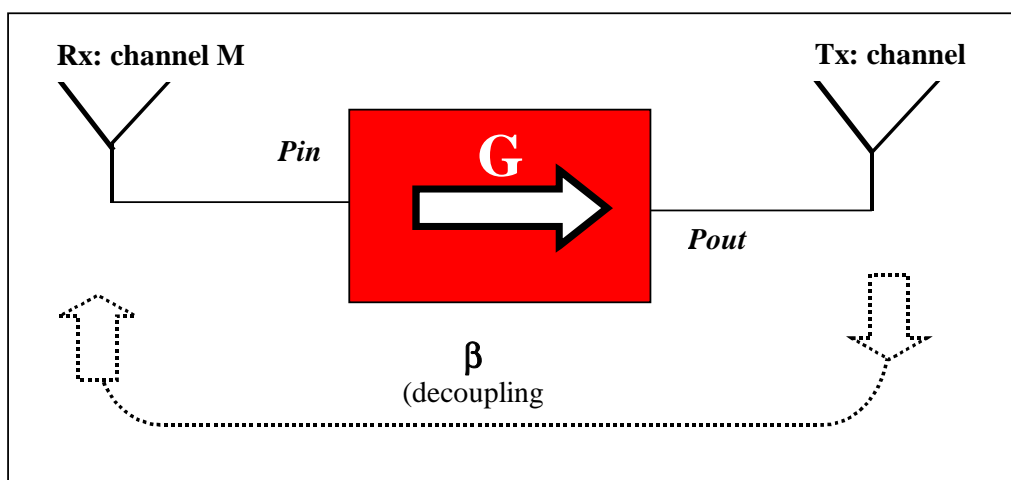

Figure 9.4: Illustration of an on-channel repeater

The key trade-off in the deployment of an on-channel repeater is between:

- Gain (G , dB) expected from the device.
- Decoupling (β , dB) or isolation between the output of the repeater and its input.

The difference between Decoupling and Gain is known in this context as Gain Margin (dB). It is obvious that for a repeater to work without instability, Decoupling has to be larger than Gain, i.e. Gain Margin has to be positive.

The peak-to-peak ripple in the transfer function depends on the Gain Margin as follows:

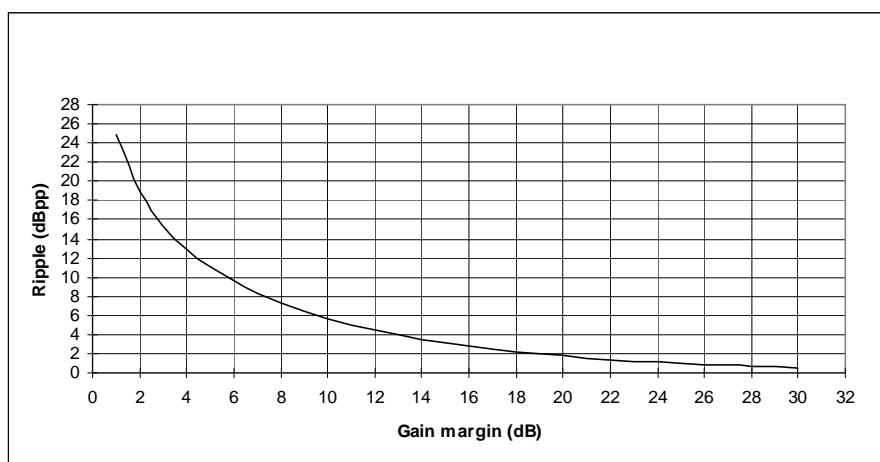

Figure 9.5: Peak-to-Peak Ripple (dB) in the transfer function against Gain Margin (dB)

The effect of ripple in the transfer function is a degradation of the C/N of the DVB-H carriers falling in the valleys of the transfer function. The effect will, hence, be scarcely significant if the C/N of the signal received is well above that required for QEF reception, and the effect will have to be taken into account if the C/N is near that required for QEF reception, in particular at the edges of the covered area.

The conditions under which an on-channel repeater effectively improves the coverage of an existing DVB-H are the following:

- The decoupling between the output and the input of the repeater is very high (e.g. higher than 80 dB). A careful design of receiving antenna, transmitting antenna, and, in particular, the choice of their disposition in the site and with respect to surrounding obstacles is crucial.
- The difference between the desired emitted power and the power received by the repeater, i.e. the operational gain, is lower than the existing decoupling. A safe difference may be considered 10 dB.

In practical terms, the sequence of actions to check the suitability of a site to accommodate an on-channel receiver may be the following:

- Check the level of power received from a neighbouring transmitter.
- Check the level of power fed back from the repeater.
- Identify the receiving antenna type and its location in the site, which maximizes the difference between power received from the transmitter and power fed back from the repeater. Measure power received from the neighbouring transmitter; measure decoupling.
- Calculate Gain (G) as the difference between desired emitted power and power received from the neighbouring transmitter.
- Calculate Gain Margin as the difference between decoupling and G.

If Gain Margin is near to 0 or negative, try to optimize conditions in the site. Otherwise, the site will not accept an on-channel repeater at the desired emitted power.

Some on-channel repeaters already include internal echo-cancellers in their devices. This element adds an internal Decoupling to the external Decoupling, thus allowing for a higher total effective Decoupling. Improvements of more than 15 dB have been reported.

The use of echo-cancellers in on-channel repeaters thus brings two benefits:

- the deployment of repeaters in sites where it would otherwise reveal itself unfeasible;
- a reduction of in-band ripple thus improving quality of the received signal in the area covered by the repeater.

9.4.2 Frequency synchronized transposing repeaters

An interesting alternative approach to both the on-channel repeater described above, and to a regularly synchronized SFN, is to use a central transmitter and a set of transposers. The transposers receive the signal from the central transmitter on one frequency and retransmit it on a common second frequency (without prior DVB-T de/remodulation). The set of transposers therefore form an SFN on this second frequency, see figure 9.6.

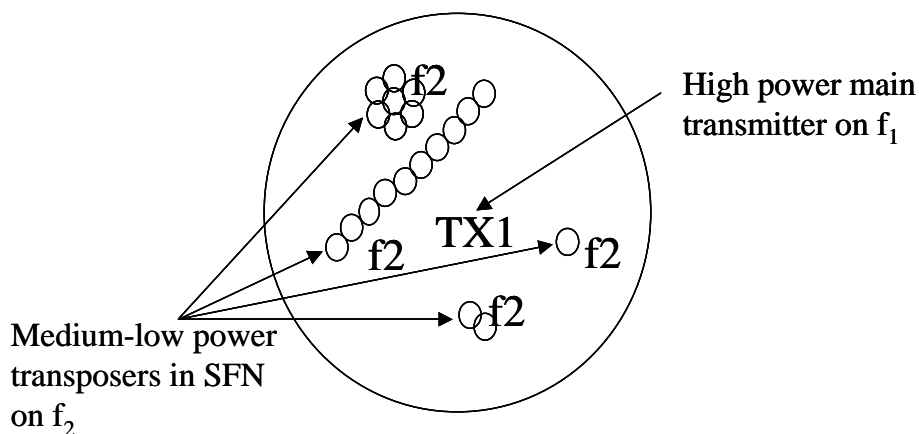

Figure 9.6: Example of a two frequency SFN with a central transmitter and various transposers

This approach offers a number of important advantages to the on-channel repeater, the regularly synchronized SFN and to the traditional (unsynchronized) transposer:

- No need for dedicated distribution to each site.
- No need for (active) time synchronization of the SFN.
- No need for DVB-T/H modulator at each site.
- No power limitation (in contrast to on-channel repeater). No isolation problems. Simple installation.
- Single transposer frequency for a wide area.

The role for the main transmitter could be to provide wide area outdoor coverage (possibly in combination with other SFN-synchronized transmitters) and to feed all the transposers. The role for the transposer network on the second frequency could be to provide indoor coverage (in combination with the main transmitter) in those areas where this is required. To fulfil this coverage requirement there is a need for a much denser network, especially in urban areas, than what is possible with the traditional main broadcast sites. The transposer SFN would then be a simple and cost-effective way of providing this coverage.

It should be noted that to achieve in-door coverage requirements, optimum exploitation of the potential diversity gain provided by SFNs is extremely important. Due to the fact that there are no restrictions in the antenna diagram, omni-directional antennas could be fully used (in contrast to the case with on-channel repeaters), and therefore potentially provide full SFN diversity gain.

One obvious drawback is of course that the transposers require a second frequency. However, since the transposer network does normally not provide continuous coverage (they may be restricted to urban and suburban areas) and often contains many transposers within each SFN, the possibility for frequency reuse at other locations is very good. The required number of transposer frequencies to cover a country should therefore be far less than the required number of frequencies for the main transmitter network. Furthermore, due to the fact that within a transposer SFN the site heights are limited and that the distance between transposer sites, is likely to be small compared to the guard interval (times the speed of light), there will probably be little or no problems with self-interference within the transposer SFN, even when it is quite large.

Time synchronization

Due to the fact that the signal is received off-air, there is no need for active time synchronization, like the DVB-SFN specification (Megafame spec.). There will be a relative time difference between different transposers, depending on the propagation delay from the main transmitter (as well as to a small extent on internal delays of the transposer). As long as the distance between neighbouring transposers is small compared to the guard interval, there should however be no problem with self-interference within an 8K SFN, using the longer guard intervals.

Frequency synchronization

There is a requirement for frequency synchronization of the emitted RF signals from the transposers in the SFN. One obvious technical solution is to use a GPS receiver with a 10 MHz frequency reference. Alternatively, the frequency reference could however be extracted locally without GPS, at each transposer, from the DVB-T signal itself, which could possibly reduce cost/complexity of the total transposer installation, especially if low power transposers in high volumes become a reality. There are at least two principal different methods for this:

- If the bitrate of the MPEG-TS is locked to GPS it is possible to regenerate the frequency reference from the TS at the transposer by demodulating the DVB-T signal and extracting the TS. The extracted reference is then used to synthesize the RF frequency with appropriate accuracy.
- If the RF frequency of the DVB-T signal from the main transmitter is locked to GPS it should be possible to use e.g. AFC algorithms of a DVB-T receiver at the transposer to extract the frequency error of the local oscillator used for the demodulation. With this frequency error estimated the frequency error can be corrected and the RF frequency can in principle be synthesized with appropriate accuracy.

9.5 Guidelines for the use of DVB-H in 5 MHz channel bandwidth

9.5.1 Modulation Parameters

Operation within a 5 MHz bandwidth can be achieved by a simple linear scaling of the OFDM parameters from their 6 MHz, 7 MHz or 8 MHz counterparts (see EN 300 744 [i.1], annex G). An obvious effect of such scaling is a reduction in system payload, which may be mitigated in other ways, such as reduction in convolutional code strength, depending upon the required network performance. Other effects that also need to be accounted for may occur. A short description of the most notable of these effects and how they may be accounted for is given below. For any given mode, 2K, 4K or 8K, the number of carriers remains fixed, regardless of bandwidth. Hence, reduction of the operating bandwidth to 5 MHz presents the narrowest possible carrier spacing for a given mode. This reduction of carrier spacing may affect system performance primarily in three respects; an increase in the symbol period, tolerance to phase noise, and tolerance to Doppler shift in a mobile environment. Please note that, depending upon network requirements, it may be possible to change to a different mode to mitigate this effect, and the availability of an additional 4K mode in DVB-H may be beneficial in this respect.

9.5.1.1 Symbol Period

A reduction in carrier spacing will necessarily require an increase in the symbol period to maintain orthogonality, as one is a reciprocal of the other. As indicated above, the most obvious effect of this is to reduce the system payload. It has also to be borne in mind, however, that for any given guard interval fraction the absolute length of the guard interval will increase. This increase may be beneficial in SFN design. If SFN parameters are not an issue, then the reduction in payload may be mitigated to some extent by changing to another guard fraction. For example, an 8K, 8 MHz system with a guard fraction of 1/4 produces an interval of 224 μ s. If an equivalent 5 MHz system is envisaged, a guard fraction of 1/8 produces an interval of 179 μ s, which may be considered a suitable alternative, depending upon network parameters.

9.5.1.2 Phase Noise

In COFDM systems, phase noise occurs primarily in up- and down-conversion oscillators in the transmitter and receiver and they need to be controlled to prevent performance degradation. The effect of phase noise at frequencies below the carrier spacing can be mitigated by common phase error correction in the receiver. However, when the frequency of the phase noise exceeds the carrier spacing, the resultant effect is inter-carrier interference that cannot be removed. For this reason, the limits of tolerable phase noise are different above and below a frequency equivalent to the carrier spacing. The reduction of the carrier spacing to effect a 5 MHz implementation will, therefore, place a tighter tolerance on phase noise and needs to be duly accounted for in system implementation.

The second "knee" in the chart, shown occurring at around 3 KHz in this case, is located approximately at a frequency equivalent to the carrier spacing. Any reduction in carrier spacing should therefore be accompanied by an equivalent change to the tolerable phase noise parameters.

9.5.1.3 Doppler Shift

In a mobile environment, the tolerance to Doppler shift is an important parameter for the network planner to consider. In a similar manner to phase noise (above), this tolerance is directly related to the carrier spacing. Therefore, when designing a 5 MHz network intended to deliver services to mobile receivers, the effect of the reduced carrier spacing needs to be accounted for. The effect of Doppler shift can be mitigated to a limited extent within the demodulator design. However, in the DVB-H system the availability of MPE-FEC is also helpful in mitigating the effect of Doppler shift at the system level. Increasing the amount of applied MPE-FEC will, of course, reduce the available system payload. This may be acceptable within the context of a given network but, if not, it may be possible to recover some payload capacity by using a different convolutional code rate. Convolutional coding has an immediate impact upon the Gaussian performance, which MPE-FEC has little effect upon. Conversely, MPE-FEC provides benefit in terms of Doppler tolerance, upon which convolutional code strength has little effect. It is, therefore, possible to "trade" one for the other, to some extent, to provide a compromise between performance at speed and payload, although the effects of such changes would be difficult to predict accurately and would probably best be verified by field test.

9.5.2 Network Planning Considerations

The use of a 5 MHz bandwidth, almost by definition, implies the use of frequency spectrum other than that allocated for broadcast use. Such spectrum is usually organized on a 6 MHz, 7 MHz or 8 MHz raster, as signified by the inclusion of such bandwidths within the body of the DVB-T specification. Deployment of services within broadcast bands implies that they will operate in adjacent-channel or co-channel relationships with similar DVB signals, or analogue signals of well known characteristics. "Protection ratios" for such relationships are either already well-established or readily determined from such well-established values (TR 101 190 [i.5]). However, operation outside of broadcast bands implies that neighbouring transmissions may be of any standard. Such standards may also vary significantly from the relatively fixed predictable nature of broadcast signals. Network topologies may also vary significantly, e.g. a mobile telephony network consisting of multiple fixed location variable-power base-stations and a very large number of mobile variable power handsets. Operation in spectrum adjacent to such a network could prove extremely challenging in terms of receiver design, and due account has to be made of such scenarios.

10 Reference Receiver

NOTE: This clause is intended as a general guidance to DVB-H network operators, it should not be regarded as a receiver specification.

10.1 Foreword on expected performance

DVB-H performance aspects described in this clause are mainly results of the laboratory and field test work carried out in the DVB-H Verification Task Force and the Wing-TV project.

The DVB-H receivers will have many similarities in performance with the DVB-T receivers as both share the same DVB-T physical layer. Differences are mainly caused by the addition of the MPE-FEC in the link layer and by the handheld nature of the receiver. As the payload in DVB-H is IP-packets and as the time slicing mechanism is used, also the used degradation criterion will be different from the traditional DVB-T systems. In general the expected RF-performance, like linearity etc., will be very similar than in DVB-T receivers when measured with same methods and degradation criterion, but if the DVB-H degradation criterion is used the results will be different.

The MPE-FEC will improve mobile performance of the DVB-H receivers in TU-channel both in C/N and maximum achievable Doppler. The relative improvement in Doppler seems to be dependent on the basic Doppler performance of the DVB-T receiver. If the receiver has already very high Doppler performance, close to the theoretical limits, the MPE-FEC gain will be smaller, it merely helps to reach the point where the synchronization fails in any case. If the Doppler performance of the DVB-T receiver is moderate, fairly high improvement can be expected resulting quite good DVB-H Doppler performance. If the MPE-FEC is applied to a non-mobile DVB-T receiver, with low Doppler performance, the relative gain will be good, but the resulting overall DVB-H Doppler performance is not suitable for mobile use.

Gain in C/N in mobile TU-channel is depending on the Doppler frequency applied. At moderate Dopplers between 10 Hz and 90 % of the maximum Doppler the curve is very flat and has a constant gain of 6 dB to 7 dB when compared to DVB-T with the same receiver. The maximum usable F_d in DVB-H is closer to the $F_{d,max}$ than in case of DVB-T due to the shape of the curve. At very low Dopplers (in the order of few Hz or less) the C/N-requirement will raise as the virtual time interleaving of the MPE-FEC becomes shorter than the coherence time of the channel. The actual Doppler frequency where this happens is dependent on the length of the time slice burst, which is roughly equal to the time interleaving depth.

C/N-improvements in portable indoor and outdoor (pedestrian) cases are not as clear as in mobile TU-channel. DVB has traditionally been using the DVB-Rayleigh channel to describe the portable reception conditions and this clause includes estimates for the theoretical DVB-H C/N-performance in a 6-tap approximation of the DVB-Rayleigh channel. The effect of the MPE-FEC is small as no Doppler is present and the gain over the DVB-T figures is mainly coming from the fact that error criterion is different from the QEF used with DVB-T. Wing-TV project developed two new channel models for portable use, Pedestrian Indoor (PI) and Pedestrian Outdoor (PO) channels. These are SFN-channels and include a small 1,5 Hz Doppler. Still the effect of the MPE-FEC moderate selection is rather small.

The MPE-FEC will also improve tolerance to impulse interference. Laboratory tests have verified this to be true, but it is very difficult to quantify this in any simple way so that it could be included in the reference receiver specification at the time of writing. However, it seems that the gain in C/I is higher in portable and mobile channels than in Gaussian channel where only the impulses are present. This will probably emphasize the benefit of the MPE-FEC in portable and mobile reception conditions as improvements are coming from both C/N and C/I.

The noise figure of a hand held terminal with integrated antenna is slightly lower than in the current set top boxes. On the other hand a GSM-reject filter is needed in most cases to enable interoperability with GSM-900 system and this will raise the noise figure. A noise figure of 6 dB has been specified for the reference receiver with GSM-reject filter.

Designing integrated antennas for DVB-H terminals is challenging due to the used frequency range and the small size of the terminal. Indicative figures for planning purposes are given in this clause.

Performance of the transmission system can only be transformed into *quality of service* for DVB-H users if receivers make use of the benefit from DVB-H specific features embedded in the on-air signal to cope with transmission impairments occurring in the various situations expected for handheld terminals. So the use of MPE-FEC is strongly recommended.

DVB-H targets, for the first time in the life of DVB, handheld terminals. This equipment, using a light weight battery power pack and produced in very high volume, imposes the requirement for a very careful design to provide the best trade-off between cost, complexity and performance.

10.1.1 Service aspects

Transmitting low-bitrate services in DVB-H, i.e. using time slicing, could be done either by having very short bursts occurring with a short periodicity or having long bursts separated by a long off-time period. Even though both options are allowed within DVB-H transmission systems, it should be noted that the second method (long bursts occurring rarely) will have the negative effect of drastically increasing the access time to the service, even reaching an unacceptable time for the user (e.g. if the access time is too long, the user will probably abort the access procedure).

If the first method (short bursts occurring frequently) optimizes the service access time (i.e. giving to the user the feeling of an *always-on* service), power saving in the receiver could be compromised. While the DVB-H time-sliced delivery method expects to help receiver designers to implement a power saving strategy, this delivery network effort can be totally jeopardized by receivers having a too long "wake-up" time before effective demodulation.

In a situation where, to improve access time for the low-bitrate services, short bursts are delivered with a short periodicity, it could occur that the RF and demodulator part of the receiver remains permanently on if the receiver wake-up time is greater than the inter-burst period. Numerous techniques can be implemented in the receiver to circumvent this problem (e.g. repetitive wake-up could be made short by reusing formerly acquired demodulation characteristics, by using fine evaluation of the off-time period, etc.).

As experience has not yet been acquired on the implementation of the time slicing strategy within mobile receivers, component manufacturers are encouraged to consider globally mobile performances, wake-up time optimization and power saving, while remaining in the cost range targeted for handheld terminals.

10.2 DVB-H reference receiver model

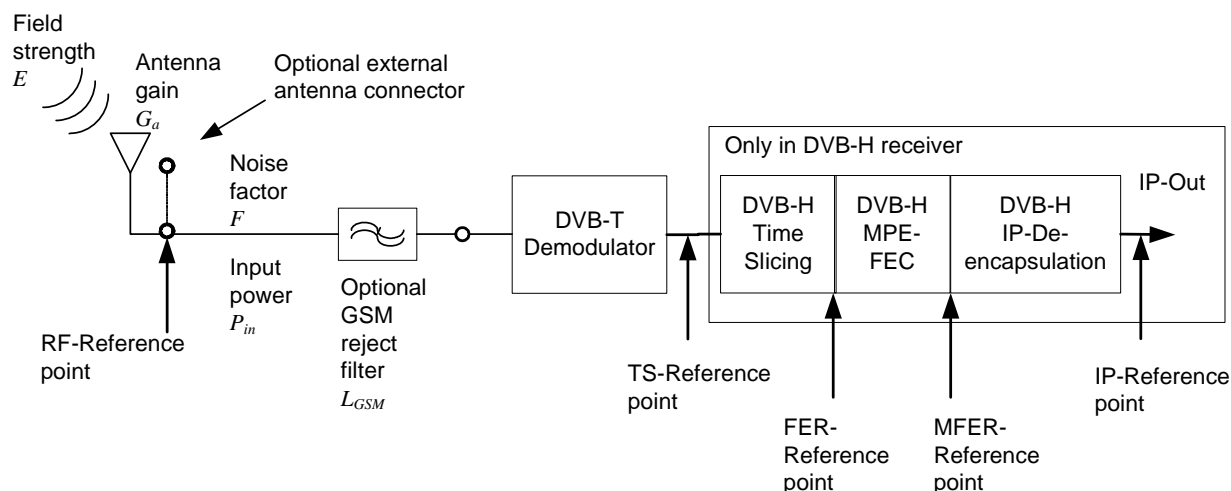

Figure 10.1: DVB-H receiver reference model

The receiver performance is defined according to the reference model shown in figure 10.1. Reference points are defined for:

- RF;
- transport stream;
- frame errors before MPE-FEC;
- frame errors after MPE-FEC;
- IP-stream.

All the receiver performance figures are specified at the RF-reference point, which is the input of the receiver. Note that in some cases it is necessary to add the GSM reject filter in front of the receiver to prevent the high power from the GSM transmitter to enter the DVB-H receiver. Typically the insertion loss of the filter L_{GSM} is in the order of 1 dB, raising the overall noise figure to 6 dB at frequencies below 700 MHz (see clause 10.3.1). At higher frequencies between 700 MHz and 750 MHz (close to the cut of frequency of the filter) the noise figure will raise even more due to higher insertion loss of the GSM reject filter.

Relation between field strength and input power is:

$$E = \sqrt{4\pi\eta \frac{P_{in}}{G_a} \times \frac{f}{c}} \quad \text{In dBs : } E[\text{dB}\mu\text{V} / \text{m}] = P_{in}[\text{dBm}] - G_a[\text{dB}] + L_{GSM} + 77,2 + 20\lg f[\text{MHz}] \quad (5)$$

where, $\eta = 120\pi \Omega$.

10.3 Minimum receiver signal input levels for planning

10.3.1 Noise Floor

The receiver should have a system noise figure better than 6 dB at the reference point at sensitivity level of each DVB-H mode when a GSM reject filter is used.

The 6 dB noise figure corresponds to the following noise floor power levels:

$$P_n = -99,2 \text{ dBm, [for 8 MHz channels, BW = 7,61 MHz]}$$

$$P_n = -99,7 \text{ dBm, [for 7 MHz channels, BW = 6,66 MHz]}$$

$$P_n = -101,4 \text{ dBm, [for 6 MHz channels, BW = 5,71 MHz]}$$

$$P_n = -101,2 \text{ dBm, [for 5 MHz channels, BW = 4,76 MHz]}$$

10.3.2 Minimum C/N-requirements

10.3.2.1 DVB-H degradation criterion

In DVB-H a suitable degradation criterion is the MPE-FEC frame error rate (MFER), referring to the error rate of the time sliced burst protected with the MPE-FEC. As an erroneous frame will destroy the service reception for the whole interval between the bursts, it is appropriate to fix the degradation point to the frequency of lost frames. Obviously the used burst and IP-parameters will affect the final service quality obtained with certain fixed MFER, but experience has shown that the behaviour is very steep and a very small change in C/N will result a large change in MFER. MFER is the ratio of the number of erroneous frames (i.e. not recoverable) and total number of received frames. To provide sufficient accuracy, it is necessary to analyse at least 100 frames.

$$MFER[\%] = \frac{\text{Number of Erroneous Frames} \times 100}{\text{Total Number of Frames}} \quad (6)$$

It has been agreed that 5 % MFER is used to mark the degradation point of the DVB-H service. Note that the service reception quality at the 5 % MFER degradation point may not meet the QoS requirement in all cases. The criterion is nevertheless suitable for measurements, and a small 0,5 dB to 1 dB carrier power increase will improve the reception quality to less than 1 % MFER.

It is also possible to estimate the MFER with good accuracy without performing the actual MPE-FEC calculation by just observing row by row the number of erroneous bytes and comparing this with the error correction capability of the RS-code used and marking the row erroneous or non-erroneous. If all rows are non-erroneous the frame is non-erroneous. With this method it is possible to decode all services (i.e. the whole transport stream) in parallel and shorten the observation time for the 100 frames needed.

In DVB-H receivers with no MPE-FEC the frame error rate criterion can be used in a slightly different way. A frame is marked erroneous if any TS-packet within the frame is erroneous. This criterion is called FER and degradation point is set to 5 % value. Note that 5 % FER may lead to better actual QoS than 5 % MFER as in FER it is possible that only a few TS-packets within the frame are erroneous, but in MFER a non recoverable frame is probably highly corrupted. The actual performance figures with FER 5 % are very similar what would be achieved using ESR 5 criterion to the transport stream directly.

10.3.2.2 C/N Performance in Gaussian Channel

The DVB-H receiver is expected to have the performance given in table 10.1, when noise (N) is applied together with the wanted carrier (C) in a signal bandwidth of 7,61 MHz. Degradation point criteria is MFER 5 %. The values are calculated using the theoretical C/N figures given in EN 300 744 [i.1] added by an implementation margin of 1,1 dB for QPSK, 1,3 dB for 16QAM and 1,5 dB for 64QAM modes and a receiver excess noise source value P_x of -33 dBc (see [i.7] for the noise model). An ideal transmitter is assumed. The values are valid for all MPE-FEC code rates. A 1 dB difference between DVB-T QEF C/N and MFER 5 % is assumed.

Table 10.1: C/N (dB) for 5 % MFER in Gaussian channel

Modulation	Code rate	Gaussian
QPSK	1/2	3,6
QPSK	2/3	5,4
16-QAM	1/2	9,6
16-QAM	2/3	11,7
64-QAM	1/2	14,4
64-QAM	2/3	17,3

10.3.2.3 C/N Performance in DVB-T Rayleigh channel (P1)

The DVB-H receiver is expected to have the performance given in table 10.2 when noise (N) is applied together with the wanted carrier (C) in a signal bandwidth of 7,61 MHz. Degradation point criteria is MFER 5 %. The values are calculated using the theoretical C/N figures given in TR 101 190 [i.5] added by an implementation margin of 1,6 dB for QPSK, 1,8 dB for 16QAM and 2,0 dB for 64QAM modes and using a receiver excess noise source value P_x of -33 dBc (see [i.7] for the noise model). An ideal transmitter is assumed. The DVB-H figures are valid for all MPE-FEC code rates.

Table 10.2: C/N (dB) for 5 % MFER in portable channel

Modulation	Code rate	Rayleigh (P_1)
QPSK	1/2	6,5
QPSK	2/3	10,5
16-QAM	1/2	12,8
16-QAM	2/3	16,7
64-QAM	1/2	17,9
64-QAM	2/3	22,4

10.3.2.4 C/N Performance in portable indoor (PI) and portable outdoor (PO) channels

The DVB-H receiver is expected to have the performance given in table 10.3 when noise (N) is applied together with the wanted carrier (C) in a signal bandwidth of 7,61 MHz. Degradation point criteria MFER 5 % is used. The C/N performance figures are based on the state of the art receivers on the market added with a 2 dB margin.

Table 10.3: C/N (dB) for 5 % MFER in PI & PO channel

Modulation	Code rate	MPE-FEC code rate	PI	PO
QPSK	1/2	1/2	6,6	7,6
QPSK	1/2	2/3	6,8	7,8
QPSK	1/2	3/4	7,0	8,0
QPSK	1/2	5/6	7,2	8,2
QPSK	1/2	7/8	7,4	8,4
QPSK	2/3	2/3	9,8	10,8
QPSK	2/3	3/4	10,0	11,0
QPSK	2/3	5/6	10,2	11,2
QPSK	2/3	7/8	10,4	11,4
16-QAM	1/2	2/3	12,8	13,8
16-QAM	1/2	3/4	13,0	14,0
16-QAM	1/2	5/6	13,2	14,2
16-QAM	1/2	7/8	13,4	14,4
16-QAM	2/3	2/3	15,8	16,8
16-QAM	2/3	3/4	16,0	17,0
16-QAM	2/3	5/6	16,2	17,2
16-QAM	2/3	7/8	16,4	17,4
64-QAM	1/2	5/6	17,7	18,7
64-QAM	1/2	7/8	17,9	18,9
64-QAM	2/3	2/3	20,6	21,6
64-QAM	2/3	3/4	20,8	21,8
64-QAM	2/3	5/6	21	22

10.3.2.5 C/N performance in Mobile Channels

The used reference receiver model describes the DVB-H receiver performance in an idealized way using two figures, C/N_{\min} and Fd_{3dB} . C/N_{\min} gives the minimum required C/N for MFER 5 %. The C/N-curve is flat up to high Doppler frequencies, but is not applicable to very low Doppler frequencies $Fd < 1/\text{burst duration}$. Fd_{3dB} gives the Doppler frequency, where the C/N requirement has raised 3 dB from the C/N_{\min} value. Note that Fd_{3dB} is almost equal the Fd_{\max} . The behaviour of the reference receiver is shown in figure 10.2.

When the reference receiver is used for planning purposes, the planning C/N should be the C/N_{\min} as this is valid for high Doppler frequencies due to the flatness and sharpness of the curve.

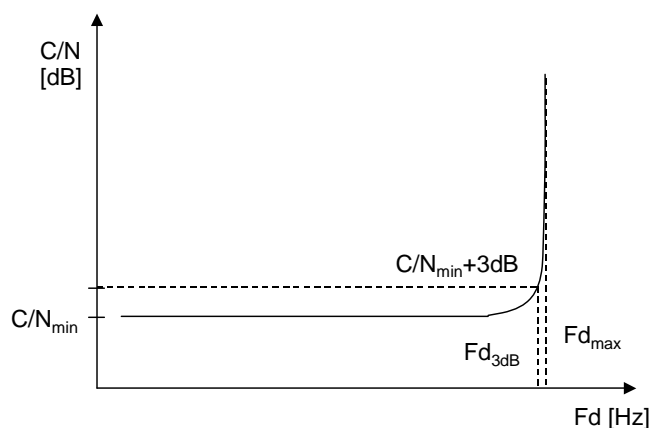

Figure 10.2: DVB-H reference receiver C/N behaviour in Mobile Channel

The DVB-H receiver is expected to have the performance given in table 10.4 when noise (N) and Doppler shift (Fd) is applied together with the wanted carrier (C) in mobile TU-6 channel. The figures are given for guard interval 1/4. The C/N performance is based on the state of the art DVB-H receivers with added 2 dB margin. The Doppler performance is derived from a use case analysis where the target speed with 8k mode at 750 MHz is 130 km/h. This corresponds to a Doppler frequency of 100 Hz. The 4k and 2k Doppler performance is obtained by multiplying the 8k performance by 2 and 4. For modes where this cannot be met with the state of the art receivers a smaller practical figure is given. Roughly 10 Hz margin is used in these cases.

Table 10.4: DVB-H C/N (dB) in mobile channel for 5 % MFER

Guard interval = 1/4			2k		Speed at Fd_{3dB} km/h		4k		Speed at Fd_{3dB} km/h		8k		Speed at Fd_{3dB} km/h	
Modulation	Code rate	MPE-FEC CR	C/N _{min} dB	Fd _{3dB} Hz	474 MHz	746 MHz	C/N _{min} dB	Fd _{3dB} Hz	474 MHz	746 MHz	C/N _{min} dB	Fd _{3dB} Hz	474 MHz	746 MHz
QPSK	1/2	1/2	8,5	400	911	579	8,5	200	456	290	8,5	100	228	145
		2/3	9,0	400	911	579	9,0	200	456	290	9,0	100	228	145
		3/4	9,5	400	911	579	9,5	200	456	290	9,5	100	228	145
		5/6	10,0	400	911	579	10,0	200	456	290	10,0	100	228	145
		7/8	10,5	400	911	579	10,5	200	456	290	10,5	100	228	145
QPSK	2/3	2/3	12,0	400	911	579	12,0	200	456	290	12,0	100	228	145
		3/4	12,5	400	911	579	12,5	200	456	290	12,5	100	228	145
		5/6	13,5	400	911	579	13,5	200	456	290	13,5	100	228	145
16-QAM	1/2	2/3	15,0	400	911	579	15,0	200	456	290	15,0	100	228	145
		3/4	15,5	400	911	579	15,5	200	456	290	15,5	100	228	145
		5/6	16,5	400	911	579	16,5	200	456	290	16,5	100	228	145
		7/8	17,5	400	911	579	17,5	200	456	290	17,5	100	228	145
16-QAM	2/3	2/3	18,0	380	866	550	18,0	190	433	275	18,0	95	216	138
		3/4	18,5	380	866	550	18,5	190	433	275	18,5	95	216	138
		5/6	19,5	380	866	550	19,5	190	433	275	19,5	95	216	138
		7/8	20,5	380	866	550	20,5	190	433	275	20,5	95	216	138
64-QAM	1/2	5/6	21,5	200	456	290	21,5	100	228	145	21,5	50	114	73
		7/8	22,5	200	456	290	22,5	100	228	145	22,5	50	114	73
64-QAM	2/3	2/3	25,0	120	273	174	25,0	60	137	87	25,0	30	68	43
		3/4	25,5	120	273	174	25,5	60	137	87	25,5	30	68	43
		5/6	27,0	120	273	174	27,0	60	137	87	27,0	30	68	43

It is important to notice the current evolution of the DVB-H receiver's performance. New receivers have demonstrated performance of more than 250 Hz of Fd_{3dB} in 8k 1/4, and may be improved in the coming years. New reception techniques allows a proper channel estimation of fast changing channels, and the reduction of the effects of typical Doppler fading's errors in the final performance. Finally Doppler performance will not be longer an issue in DVB-H networks.

These improvements will allow the utilization of 8k modes in Fd demanding channels like High Speed Trains, reducing the cost of networks.

10.3.3 Minimum Input Levels

The receiver should provide reference BER for the minimum signal levels (P_{min}) stated below and higher:

$$P_{min} = -99,2 \text{ dBm} + C/N \text{ [dB]}, \text{ [for 8 MHz]}$$

$$P_{min} = -99,7 \text{ dBm} + C/N \text{ [dB]}, \text{ [for 7 MHz]}$$

$$P_{min} = -100,4 \text{ dBm} + C/N \text{ [dB]}, \text{ [for 6 MHz]}$$

$$P_{min} = -101,2 \text{ dBm} + C/N \text{ [dB]}, \text{ [for 5 MHz]}$$

where C/N is specified in clause 10.2.2 and is depending on the channel conditions and DVB-H mode.

10.4 Antenna issues for DVB-H Handheld terminals

10.4.1 Integrated antenna

The antenna solution in a small hand held terminal like a mobile phone is typically an integral part of the terminal construction and will therefore be small when compared to the wavelength. If the antenna has to cover the whole wide tuning range of the UHF-band, it probably has to be matched with a tunable matching circuit. The resistive part of antenna impedance (radiation resistance), which is to be matched to the receiver input impedance, will be rather small due to the small size of the antenna ($< 1/10 \lambda$). This leads to rather high losses and to a low overall efficiency. Moreover in this type of terminal the ground plane does not function any more, but acts as a radiator. However even the size of the radiating ground plane is small when compared to the wavelength resulting low radiation efficiency.

Another issue is the influence of the user on the radiation characteristic of the antenna. Depending on the relative position of the user to the hand held terminal, the human body could act as an absorber or a reflector.

Current understanding of the overall design problem indicates that the typical antenna gain at the lowest UHF-band frequencies would be in the order of -10 dBi increasing to -5 dBi at the end of UHF-band. Nominal antenna gain between these frequencies can be obtained by linear interpolation.

In case a GSM 900 is used in a convergence terminal the usable frequency range is limited to channel 55 [746 MHz] due to the interoperability considerations. In case GSM 900 is not used this limitation does not apply.

Generally, no polarization discrimination can be expected from this type of portable reception antenna and the radiation pattern in the horizontal plane is omni-directional.

Typical gain of the integrated antenna for planning purposes is presented in table 10.5.

Table 10.5: Typical antenna gain for integrated antennas in handheld terminals

Frequency [MHz]	Gain [dBi]
474 [channel 21]	-10
698 [channel 49]	-7
858 [channel 69]	-5

10.4.2 External antenna

Urban indoor reception is often affected by high levels of building penetration losses. Therefore, in some cases it might be difficult to guarantee the appropriate reception quality using low gain integrated antennas as explained in clause 10.4.1. In these cases, the following solutions could be foreseen:

- Use of an external antenna instead of integrated antenna.
- Use of *wired* headsets as the external antenna.
- Provision of an antenna connector, to facilitate the use of a user-connected external antenna.
- In case that only integrated antenna is available, the use of *Indoor / In-vehicle gap fillers*.

The achievable antenna gain in case of external antenna depends on the specific implementation. The expected range of values is between -3 dBi and +3 dBi, an improvement of about 7 dB with respect to an integrated antenna. Hand held terminals with external antenna gain may dramatically reduce the network complexity/cost requirements, while guaranteeing at the same time the customer satisfaction for the technical service quality.

10.5 Diversity reception

Receiver sensitivity may be improved by adding diversity reception. Diversity could enhance the reception compensating poor antenna gains up to 6 dB to 9 dB in mobile channel; in portable channels, however, the benefit from diversity could be up to 3 dB to 4 dB. Diversity reception requires two or more antennas and special algorithms at the demodulation combining both inputs. As the distance between antennas should be $\lambda/2$, the practical implementation of diversity in a hand held terminals is really challenging for low frequencies (i.e. VHF and UHF bands), and feasible for higher frequencies (i.e. L-band). Although diversity could lower the complexity/cost of the network, the penalty is in the cost of the receiver.

11 Network planning

11.1 Coverage definitions

11.1.1 Introduction

It is necessary to have definitions for the coverage of a DVB-H transmitting station or a group of such stations. Such definitions may be based primarily on technical criteria but need to be readily usable for non-technical purposes.

"DVB-T service" coverage is characterized by a very rapid transition from near perfect reception to no reception at all and it thus becomes critical to be able to define at the border which areas are going to be covered and which are not. The case of DVB-H is even more demanding since reception is expected in adverse conditions (the handheld terminal is moving, body loss, no line of sight, etc.). However, because of the very rapid transition described above, there is a cost penalty if the coverage target within a small area (e.g. 100 m \times 100 m) is set too high. This occurs because it is necessary either to increase the transmitter power or to provide a larger number of transmitter sites in order to guarantee coverage to the last few percent of the worst-served small areas.

11.1.2 Portable reception

In the context of DVB-H, portable antenna reception is defined as the reception at no speed or very low speed (walking speed):

- **Class A** outdoor reception where a portable receiver with an attached or built-in antenna is used:
 - outdoors at no less than 1,5 m above ground level at pedestrian speed up to 3 km/h.
- **Class B** indoor reception where a portable receiver with an attached or built-in antenna is used:
 - indoor at no less than 1,5 m above floor level in rooms at pedestrian speed up to 3 km/h;
 - on the ground floor;
 - with a window in an external wall.

NOTE: It is known that reception of DVB-H services will generally not take place at 1,5 m. However for broadcast planning purposes this is the common value, taking into account that the differences between planning at 2 m or 1 m are negligible, the present document will assume 1,5 m.

Portable antenna reception will, in practice, take place under a great variety of conditions (outdoor, indoor, ground floor, first floor, upper floors). Besides, due to the nature of DVB-H services, the handheld receiver would be probably moved (at walking speed) while being viewed. Latest investigations have shown that pedestrian reception scenarios are different to other mobile cases like car reception. Therefore new portable channel profiles (PO3 and PI3) have to be assumed for Class A and B. These profiles are described in annex D and the required C/N are reported in table 10.3 in clause 10.3.2.4. It is assumed that extreme cases, such as reception in strong shielded rooms, are disregarded.

It is to be expected that there will be a significant variation of reception conditions for indoor portable reception, depending to some extent, on the floor-level at which reception is required. However, there will also be considerable variation of building penetration loss from one building to another and also considerable variation from one part of a room to another. Also handheld receivers could suffer from body loss in certain circumstances, e.g. file downloading applications when the receiver is in the pocket. Some estimates of the probable signal level requirements for different floor-levels are given in clause 11.2. Further studies are necessary. It is to be expected that "portable coverage" be mainly aimed at *urban areas*.

11.1.3 Mobile reception

In the context of DVB-H, mobile antenna reception is defined as the reception at medium to high speed (i.e. no walking speed):

- **Class C** outdoor reception with a moving DVB-H terminal where the receiver is moved while being used:
 - outdoors at no less than 1,5 m above ground level;
 - examples: antenna integrated in a car.
- **Class D** inside reception in moving objects like cars or vehicles (e.g. bus, train, etc.):
 - indoors in a car or vehicle at no less than 1,5 m above ground level.

The C/N performance in mobile channels (see table 10.4 in clause 10.3.2.5) is nearly constant until the maximum possible speed (corresponding to Fd_{3dB}) is reached. Therefore a C/N_{min} can be considered for the most receivers in the network if it can be assumed that only a few receivers are moving with speeds near to the maximum possible speed. It should be taken into account that MPE-FEC (optional feature of DVB-H) has an important impact on the C/N_{min} value and the maximum Doppler shift.

NOTE: Body losses could also be of importance in class D under certain circumstances like if terminal is in the pocket and a file downloading is being done, however the present document do not consider this situation.

It is to be expected that there will be significant variation of reception conditions for mobile reception, depending on the environment of the DVB-H terminal (outdoors or in-vehicles). However, there will also be considerable variation of entry loss caused by the different construction of cars and vehicles.

In both cases, it is assumed that the mobile receiver is moved during reception and/or large objects near the receiver are also moved. It is also assumed that extreme cases, such as reception in strong shielded vehicles, are disregarded.

11.1.4 Coverage area

In defining the coverage area for each reception condition, a three level approach is taken:

Receiving location

- The smallest unit is a receiving location with dimensions of about 0,5 m × 0,5 m. In the case of portable antenna reception, it is assumed that optimal receiving conditions will be found by moving the antenna or moving the handheld terminal within 0,5 m in any direction.
- Such a location is regarded as covered if the required carrier-to-noise and carrier-to-interference values are achieved for 99 % of the time.

Small area coverage

- The second level is a "small area" (typically 100 m × 100 m).

NOTE 1: It could have some benefits to use 10 m × 10 m in a similar way as in planning cellular mobile telephone networks.

- In this small area the percentage of covered location is indicated.

- The quality of coverage of a small area is classified as:
 - "Good", if at least 95 % of receiving locations at the *edge of the area* are covered for portable reception (classes A and B) and 99 % of receiving locations within it are covered for mobile reception (classes C and D).
 - "Acceptable", if at least 70 % of locations *at the edge of the area* are covered for portable reception (classes A and B) and 90 % of receiving locations within it are covered for mobile reception (classes C and D).

NOTE 2: Those percentages apply to the **edge** of the coverage area, the average value of the area is then a greater value.

Coverage area

- The third level is the coverage area:
 - The coverage area of a transmitter, or a group of transmitters, is made up of the union of the individual small areas in which a given class of coverage is achieved.

11.2 Minimum field strength considerations

11.2.1 Minimum receiver signal input level

To illustrate how the C/N ratio influences the minimum signal input level to the receiver, the latter has been calculated for five representative C/N ratios in the range from 2 dB to 26 dB. For other values simple linear interpolation can be applied.

The receiver noise figure has been chosen as 6 dB for all the frequency bands IV to V, as was used in clause 10.2 for the model DVB-H receiver with GSM reject filter, and thus the minimum receiver input signal level is independent of the transmitter frequency. If other noise figures are used in practice, the minimum receiver input signal level will change correspondingly by the same amount.

The minimum receiver input signal levels calculated here are used in clause 11.2.2 to derive the minimum power flux densities and corresponding minimum median equivalent field strength values for various frequency bands.

Definitions:

B:	Receiver noise bandwidth (Hz)
F:	Receiver noise figure (dB)
P_n :	Receiver noise input power (dBW)
C/N:	RF carrier to noise ratio at the receiver input required by the system (dB)
$P_{s \text{ min}}$:	Minimum receiver signal input power (dBW)
Z_i :	Receiver input impedance (75 Ω)
$U_{s \text{ min}}$:	Minimum equivalent receiver input voltage into Z_i (dB μ V)

Constants:

k:	Boltzmann's constant = $1,38 \times 10^{-23}$ Ws/K
T_0 :	absolute Temperature = 290 K

Formulae used:

$P_n =$	$F + 10 \log (k \times T_0 \times B)$
$P_{s \text{ min}} =$	$P_n + C/N$

$$U_{s \text{ min}} = P_{s \text{ min}} + 120 + 10 \log(Z_i)$$

Table 11.1: Minimum equivalent input signal level to receiver

Frequency Band: IV, V						
Equivalent noise bandwidth	B (Hz)	$7,6 \times 10^6$	$7,6 \times 10^6$	$7,6 \times 10^6$	$7,6 \times 10^6$	$7,6 \times 10^6$
Receiver noise figure	F (dB)	6	6	6	6	6
Receiver noise input power	P_n (dBW)	-129,2	-129,2	-129,2	-129,2	-129,2
RF signal/noise ratio	C/N (dB)	2	8	14	20	26
Min. receiver signal input power	$P_{s \text{ min}}$ (dBW)	-127,2	-121,2	-115,2	-109,2	-103,2
Min. equivalent receiver input voltage, 75 Ω	$U_{s \text{ min}}$ (dB μ V)	12	18	24	30	36

NOTE: Table 11.1 provides a derivation of minimum required signal levels. Clauses 11.2.2.2 and 11.2.2.3 provide information on the minimum median values of signal levels required in practical situations.

11.2.2 Planning Criteria

11.2.2.1 Minimum signal levels

In clause 11.2.1 the minimum signal levels to overcome noise are given as the minimum receiver input power and the corresponding minimum equivalent receiver input voltage. No account is taken of any propagation effects. However, it is necessary to consider these effects when considering DVB-H reception in a practical environment.

In defining coverage it is indicated that due to the very rapid transition from near perfect to no reception at all, it is necessary that the minimum required signal level is achieved at a high percentage of locations. These percentages have been set at 95 % for "good" and 70 % for "acceptable" portable reception. For mobile reception the percentages defined were 99 % and 90 % respectively.

NOTE: It should be remembered that these percentages apply to the edge of the coverage area.

The minimum median power flux densities are calculated for:

- a) Four different receiving conditions for portable and mobile reception:
 - 1) Handheld portable outdoor reception - Class A.
 - 2) Handheld portable indoor reception at ground floor - Class B.
 - 3) Integrated car antenna mobile reception - Class C.
 - 4) Handheld mobile reception (i.e. terminals are used within a moving vehicle) - Class D.
- b) Two frequencies representing Band IV and Band V:
 - 1) 500 MHz.
 - 2) 800 MHz.
- c) Five representative C/N ratios in the range 2 dB to 26 dB in steps of 6 dB.

Representative C/N values are used for these examples. Results for any chosen system variant may be obtained by interpolation between relevant representative values.

All minimum median equivalent field strength values presented in this clause are for coverage by a single transmitter only, not for a Single Frequency Network.

To calculate the minimum median power flux density or equivalent field strength needed to ensure that the minimum values of signal level can be achieved at the required percentage of locations, the following formulas are used:

$$\phi_{\min} = P_{s \min} - A_a$$

$$E_{\min} = \phi_{\min} + 120 + 10 \log (120\pi) = \phi_{\min} + 145,8$$

$$\phi_{\text{med}} = \phi_{\min} + P_{\text{mmn}} + C_1 + L_h$$

$$\phi_{\text{med}} = \phi_{\min} + P_{\text{mmn}} + C_1 + L_h + L_b \quad (\text{in tables 11.12 to 11.13})$$

$$\phi_{\text{med}} = \phi_{\min} + P_{\text{mmn}} + C_1 + L_h + L_v \quad (\text{in tables 11.16 to 11.17})$$

$$E_{\text{med}} = \phi_{\text{med}} + 120 + 10 \log (120\pi) = \phi_{\text{med}} + 145,8$$

where:

C/N : RF carrier to noise ratio at the receiver input required by the system (dB)

ϕ_{\min} : Minimum power flux density at receiving location (dBW/m²)

E_{\min} : Equivalent minimum field strength at receiving location (dB μ V/m)

L_h : Height loss (10 m a.g.l. to 1,5 m. a.g.l.) (dB)

L_b : Building penetration loss (dB)

L_v : Vehicle entry loss (dB)

P_{mmn} : Allowance for manmade noise (dB)

C_1 : Location correction factor (dB)

ϕ_{med} : Minimum median power flux density, planning value (dBW/m²)

E_{med} : Minimum median equivalent field strength, planning value (dB μ V/m)

For calculating the location correction factor C_1 a log-normal distribution of the received signal is assumed.

The location correction factor can be calculated by the formula:

$$C_1 = \mu \times \sigma$$

where:

μ is the distribution factor, being 0,52 for 70 %, 1,28 for 90 %, 1,64 for 95 %, and 2,33 for 99 %;

σ is the standard deviation taken as 5,5 dB for outdoor reception.

See clause 11.2.2.2 for σ values appropriate for indoor reception.

While the matters dealt with in this clause are generally applicable, additional special considerations are needed in the case of SFNs where there is more than one wanted signal contribution.

11.2.2.2 Portable antenna reception

11.2.2.2.1 Criteria for portable outdoor reception

a) Signal level prediction.

The signal level prediction method to be used will be based on ITU-R Recommendation P.1546-1 [i.10], bearing in mind that this method shows differences between predicted and measured values, as do all prediction methods. An allowance may need to be made for this inherent source of inaccuracy and the overall signal level strength prediction process should take account of this element in addition to the variation of field strength with location.

- b) Integrated antennas for handheld portable reception.

The antenna solution in a small hand held terminal is typically an integral part of the terminal construction and will therefore be small when compared to the wavelength. Current understanding of the design problem indicates that the worst case antenna gain is at the lowest UHF-band. The antenna gain for three frequencies in the UHF band is given in table 10.5. For planning purposes the following values may be used for Band IV and V in Class A and B reception. The values in table 11.2 are marking the antenna gain at the lowest (UHF Band IV) and highest (UHF Band V) frequencies (see table 10.5). A linear interpolation regarding the used exact frequency could be done for network planning.

NOTE: Gain expressed in dBd is about 2 dB less than those expressed in dBi.

Table 11.2: Integrated antenna gain in dBd for hand-held reception for planning purposes

Band	Gain (dBd)
IV	-12
V	-7

- c) Signal level variations.

Field strength variations can be divided into macro-scale and micro-scale variations. The macro-scale variations relate to areas with linear dimensions of 10 m to 100 m or more and are mainly caused by shadowing and multi-path reflections from distant objects. The micro-scale variations relate to areas with dimensions in the order of a wavelength and are mainly caused by multi-path reflections from nearby objects. As it may be assumed that for portable reception the position of the antenna can be optimized within the order of a wavelength, micro-scale variations will not be too significant for planning purposes.

Macro-scale variations of the field strength are very important for coverage assessment. In general, a high target percentage for coverage would be required to compensate for the rapid failure rate of digital TV signals. Therefore an extra correction to the value derived from ITU-R Recommendation P.1546-1 [i.10] curves is required.

- d) Location percentage requirements at outdoor locations.

ITU-R Recommendation P.1546-1 [i.10] gives a standard deviation for wide band signals of 5,5 dB. This value is used here for determining the location correction factor for outdoor locations.

In portable reception to ensure a satisfactory service it is recommendable to ensure reception in the range of 90 ÷ 95 % of locations. The location correction factor for macro-scale variations is therefore:

Table 11.3: Macro-scale variation: Coverage and location correction factor

Coverage target	Location Correction Factor
> 95 %	9 dB
> 90 %	7 dB
> 70 %	3 dB

- e) Height loss.

For portable reception, the antenna height of 10 m above ground level generally used for planning purposes is not realistic and a correction factor needs to be introduced based on a receiving antenna near ground floor level. For this reason a receiving antenna height of 1,5 m above ground level (outdoor) or above floor level (indoor) has been assumed.

The propagation prediction method of ITU-R Recommendation P.1546-1 [i.10] uses a receiving height of 10 m. To correct the predicted values for a receiving height of 1,5 m above ground level a factor called "height loss" has been introduced. However, the height loss can also be specified for different types of receiving environments. CEPT/FM-PT24(04)034 (see bibliography) provides the height loss values for some type of environments as follows.

Table 11.4: Height loss for different environments

Frequency	Receiving antenna height loss		
	Rural	Suburban	Urban
500 MHz	11 dB	16 dB	22 dB
800 MHz	13 dB	18 dB	24 dB

NOTE: Values for rural proceed from the ITU-T Recommendation P.370 [i.11].

These values will be used in this clause for the calculations.

11.2.2.2.2 Criteria for portable indoor reception

a) Building penetration loss.

Portable DVB-H reception will take place at outdoor and indoor locations but also within moving objects like cars or other vehicles. The field strength at indoor locations will be attenuated significantly by an amount depending on the materials and the construction of the house. A large spread of building penetration losses and entry losses for moving objects is to be expected.

Several measurements have been carried out to verify real values of attenuation. A large spread of building penetration losses (UHF) been measured, being the practical range of the results between 7 dB and 15 dB. The following table gives a few examples of the mean value and standard deviation of the building penetration loss and the calculated standard deviation of the indoor signals.

Table 11.5a: Building penetration loss. Experiences in Finland

Case	Building penetration loss (dB)	Standard Deviation (dB)
- Suburban residential building	7	5
- A room with a window on the exterior wall in an apartment in urban environment		
- Exterior rooms in office buildings in urban environment	11	6
- Inner rooms in an apartment in urban environment		
- Inner rooms in office buildings	15	7

Table 11.5b: Building penetration loss by type of building. Experiences in France

Wall type	Building penetration loss (dB)	Standard Deviation (dB)
With windows	Normal window	8,12
	Large window	8,16
	Door with a window	8,02
	Glass + wood	7,35
	Glass + metal	10,08
Without windows	Several materials	8,80
	Wood	7,97
	Garage door	10,22

As, at the time the present document has been written, there is no clear criterion for Building Penetration losses, the present document assumes for planning purposes the following values, stated in table 11.6.

Table 11.6: Building penetration loss

Band	Median value	Standard deviation
UHF	11 dB	6 dB

- b) Influence of people walking around.

The influence of people walking around the receiving antenna has also been estimated. The signal level variations (10 % and 90 % value) ranged from +2,6 dB to -2,6 dB. These variations are relatively small and it does not seem necessary to take them into account for planning purposes.

- c) Location percentage requirements at indoor locations.

The location correction factor at indoor locations is the combined result of the outdoor variation and the variation factor due to building attenuation.

The location correction factor at indoor locations is the combined result of the outdoor variation and the variation factor due to building attenuation. These distributions are expected to be uncorrelated. The standard deviation of the indoor field strength distribution can therefore be calculated by taking the root of the sum of the squares of the individual standard deviations. As a consequence, the location variation of the field strength is increased for indoor reception.

At UHF, where the macro-scale standard deviations are 5,5 dB and 6 dB respectively, the combined value is 8,1 dB.

The resultant location correction factor at indoor locations for UHF are given in table 11.7.

Table 11.7: Location correction factor

Band	Coverage target	Correction factor
UHF	> 95 %	14 dB
UHF	> 90 %	10,5 dB
UHF	> 70 %	4 dB

The overall field strength prediction process has to take account of both the location variation and the difference between predicted and measured values.

11.2.2.3 Mobile reception

Mobile reception is defined as a reception with a moving receiver or at location where large objects moving around the receiver. It is also possible that a DVB-H terminal is used in a moving object like a car or any other moving vehicle. In this case the situation is similar to an indoor reception where the performance degradation of Doppler has also to be considered. The degradation due to the time variant channel response will yield in the degradation of C/N values. Clause 10 includes the values that should be used for planning in mobile reception. It should be taken into account the great influence of MPE-FEC on the C/N and on the maximum Doppler shift (and therefore on the maximum speed in a particular channel).

- a) Signal level variations.

Micro-scale signal variations are not considered since they are averaged along to the track by the receiver. Only macro-scale variations are taken into account when calculating location correction factors for mobile reception.

- b) Location percentage requirements for mobile reception.

ITU-R Recommendation P.1546-1 [i.10] gives a standard deviation for wideband signals of 5,5 dB. This value is used here for determining the location variation at outdoor locations for mobile reception. To cope with mobile environment higher location correction factors than for portable reception are used.

For mobile reception it is recommendable to ensure reception in the range of 95 % ÷ 99 % of locations. These location variations, relevant to Class D reception, are therefore:

Table 11.8: Macro-scale variation for mobile reception: Coverage and location correction factor

Coverage target	Correction factor
> 99 %	13 dB
> 95 %	9 dB
> 90 %	7 dB

c) Vehicle Entry Loss.

For mobile reception inside cars, or any other vehicle, entry loss has to be taken into account. For planning purposes an entry loss of 7 dB is used in case of Class D mobile reception.

d) Antennas for mobile reception.

In this case it will be necessary to distinguish between two cases: Class C and Class D reception. In Class D reception a handheld terminal is used with the same antenna gain as the one proposed in table 11.2 of clause 11.2.2.2. In Class C reception a vehicular built-in antenna is used with a greater gain than for handheld terminals. The practical standard antenna for vehicle reception is a whip antenna that is a monopole which uses the metallic roof as ground plane. The antenna gain for conventional incident wave angles depends on the position of the antenna on the roof. For passive antenna systems the values in table 11.9 can be used for planning purposes.

Table 11.9 Antenna gain in dBd for mobile reception (Class C)

Band	Gain (dBd)
Band IV	-2
Band V	-1

11.2.3 Signals levels for DVB-H planning

NOTE: The following values, stated in this clause, have to be considered as preliminary results. Work is currently ongoing.

11.2.3.1 Portable reception

Table 11.10: Minimum median power flux density and equivalent minimum median field strength in Band IV and 70 % and 95 % location probability
Receiving condition: Portable outdoor (Class A), Urban, Band IV, terminal category 3

Frequency	f (MHz)	500				
		2	8	14	20	26
Minimum C/N required by system	(dB)					
Min. receiver signal input power	$P_{s \min}$ (dBW)	-127,2	-121,2	-115,2	-109,2	-103,2
Min. equivalent receiver input voltage, 75 Ω	$U_{s \min}$ (dBW)	12	18	24	30	36
Antenna gain relative to half dipole	U_a (dB)	-12				
Effective Antenna aperture	A_a (dBm ²)	-25,3				
Min. power flux density at receiving location	ϕ_{\min} (dBW/m ²)	-101,9	-95,9	-89,9	-83,9	-77,9
Min. equivalent field strength at receiving location	E_{\min} (dB μ V/m)	44	50	56	62	68
Allowance for manmade noise	P_{mmn} (dB)	0				
Height loss	L_h (dB)	22				
Location Probability: 70 %						
Location correction factor	C_l (dB)	3				
Minimum median power flux density at 10 m a.g.l. 50 % of time and 50 % of location	ϕ_{med} (dBW/m ²)	-76,9	-70,9	-64,9	-58,9	-52,9
Minimum median equivalent field strength at 10 m a.g.l. 50 % of time and 50 % of location	E_{med} (dB μ V/m)	69	75	81	87	93
Location Probability: 95 %						
Location correction factor	C_l (dB)	9				
Minimum median power flux density at 10 m a.g.l. 50 % of time and 50 % of location	ϕ_{med} (dBW/m ²)	-70,9	-64,9	-58,9	-52,9	-46,9
Minimum median equivalent field strength at 10 m a.g.l. 50 % of time and 50 % of location	E_{med} (dB μ V/m)	75	81	87	93	99

Table 11.11: Minimum median power flux density and equivalent minimum median field strength in Band V and 70 % and 95 % location probability
Receiving condition: Portable outdoor (Class A), Urban, Band V, terminal category 3

Frequency	f (MHz)	800				
		2	8	14	20	26
Minimum C/N required by system						
Min. receiver signal input power	$P_{s \min}$ (dBW)	-127,2	-121,2	-115,2	-109,2	-103,2
Min. equivalent receiver input voltage, 75 Ω	$U_{s \min}$ (dBW)	12	18	24	30	36
Antenna gain relative to half dipole	U_a (dB)	-7				
Effective Antenna aperture	A_a (dBm ²)	-24,4				
Min. power flux density at receiving location	ϕ_{\min} (dBW/m ²)	-102,8	-96,8	-90,8	-84,8	-78,8
Min. equivalent field strength at receiving location	E_{\min} (dB μ V/m)	43	49	55	61	67
Allowance for manmade noise	P_{mmn} (dB)	0				
Height loss	L_h (dB)	24				
Location Probability: 70 %						
Location correction factor	C_l (dB)	3				
Minimum median power flux density at 1,5 m a.g.l. 50 % of time and 50 % of location	ϕ_{med} (dBW/m ²)	-75,8	-69,8	-63,8	-57,8	-51,8
Minimum median equivalent field strength at 1,5 m a.g.l. 50 % of time and 50 % of location	E_{med} (dB μ V/m)	70	76	82	88	94
Location Probability: 95 %						
Location correction factor	C_l (dB)	9				
Minimum median power flux density at 10 m a.g.l. 50 % of time and 50 % of location	ϕ_{med} (dBW/m ²)	-69,8	-63,8	-57,8	-51,8	-45,8
Minimum median equivalent field strength at 10 m a.g.l. 50 % of time and 50 % of location	E_{med} (dB μ V/m)	76	82	88	94	100

Table 11.12: Minimum median power flux density and equivalent minimum median field strength in Band IV and 70 % and 95 % location probability
Receiving condition: Portable indoor (Class B), Urban, Band IV, terminal category 3

Frequency	f (MHz)	500				
		2	8	14	20	26
Minimum C/N required by system						
Min. receiver signal input power	$P_{s \min}$ (dBW)	-127,2	-121,2	-115,2	-109,2	-103,2
Min. equivalent receiver input voltage, 75 Ω	$U_{s \min}$ (dBW)	12	18	24	30	36
Antenna gain relative to half dipole	U_a (dB)	-12				
Effective Antenna aperture	A_a (dBm ²)	-25,3				
Min. power flux density at receiving location	ϕ_{\min} (dBW/m ²)	-101,9	-95,9	-89,9	-83,9	-77,9
Min. equivalent field strength at receiving location	E_{\min} (dB μ V/m)	44	50	56	62	68
Allowance for manmade noise	P_{mmn} (dB)	0				
Height loss	L_h (dB)	22				
Building penetration loss	L_b (dB)	11				
Location Probability: 70 %						
Location correction factor	C_l (dB)	4				
Minimum median power flux density at 10 m a.g.l. 50 % of time and 50 % of location	ϕ_{med} (dBW/m ²)	-64,9	-58,9	-52,9	-46,9	-40,9
Minimum median equivalent field strength at 10 m a.g.l. 50 % of time and 50 % of location	E_{med} (dB μ V/m)	81	87	93	99	105
Location Probability: 95 %						
Location correction factor	C_l (dB)	14				
Minimum median power flux density at 10 m a.g.l. 50 % of time and 50 % of location	ϕ_{med} (dBW/m ²)	-54,9	-48,9	-42,9	-36,9	-30,9
Minimum median equivalent field strength at 10 m a.g.l. 50 % of time and 50 % of location	E_{med} (dB μ V/m)	91	97	103	109	115

Table 11.13: Minimum median power flux density and equivalent minimum median field strength in Band V and 70 % and 95 % location probability
Receiving condition: Portable indoor (Class B), Band V, terminal category 3

Frequency	f (MHz)	800				
		2	8	14	20	26
Minimum C/N required by system						
Min. receiver signal input power	$P_{s \min}$ (dBW)	-127,2	-121,2	-115,2	-109,2	-103,2
Min. equivalent receiver input voltage, 75 Ω	$U_{s \min}$ (dBW)	12	18	24	30	36
Antenna gain relative to half dipole	U_a (dB)	-7				
Effective Antenna aperture	A_a (dBm ²)	-24,4				
Min. power flux density at receiving location	ϕ_{\min} (dBW/m ²)	-102,8	-96,8	-90,8	-84,8	-78,8
Min. equivalent field strength at receiving location	E_{\min} (dB μ V/m)	43	49	55	61	67
Allowance for manmade noise	P_{mmn} (dB)	0				
Height loss	L_h (dB)	24				
Building penetration loss	L_b (dB)	11				
Location Probability: 70 %						
Location correction factor	C_l (dB)	4				
Minimum median power flux density at 10 m a.g.l. 50 % of time and 50 % of location	ϕ_{med} (dBW/m ²)	-63,8	-57,8	-51,8	-45,8	-39,8
Minimum median equivalent field strength at 10 m a.g.l. 50 % of time and 50 % of location	E_{med} (dB μ V/m)	82	88	94	100	106
Location Probability: 95 %						
Location correction factor	C_l (dB)	14				
Minimum median power flux density at 10 m a.g.l. 50 % of time and 50 % of location	ϕ_{med} (dBW/m ²)	-53,8	-47,8	-41,8	-35,8	-29,8
Minimum median equivalent field strength at 10 m a.g.l. 50 % of time and 50 % of location	E_{med} (dB μ V/m)	92	98	104	110	116

11.2.3.2 Mobile reception

Table 11.14: Minimum median power flux density and equivalent minimum median field strength in Band IV and 90 % and 99 % location probability
Receiving condition: Mobile outdoor (Class C), Rural, Band IV, terminal category 1

Frequency	f (MHz)	500				
		2	8	14	20	26
Minimum C/N required by system						
Min. receiver signal input power	$P_{s \min}$ (dBW)	-127,2	-121,2	-115,2	-109,2	-103,2
Min. equivalent receiver input voltage, 75 Ω	$U_{s \min}$ (dBW)	12	18	24	30	36
Antenna gain relative to half dipole	U_a (dB)	-2				
Effective Antenna aperture	A_a (dBm ²)	-15,3				
Min. power flux density at receiving location	ϕ_{\min} (dBW/m ²)	-111,9	-105,9	-99,9	-93,9	-87,9
Min. equivalent field strength at receiving location	E_{\min} (dB μ V/m)	34	40	46	52	58
Allowance for manmade noise	P_{mmn} (dB)	0				
Height loss	L_h (dB)	11				
Location Probability: 90 %						
Location correction factor	C_l (dB)	7				
Minimum median power flux density at 10 m a.g.l. 50 % of time and 50 % of location	ϕ_{med} (dBW/m ²)	-93,9	-87,9	-81,9	-75,9	-69,9
Minimum median equivalent field strength at 10 m a.g.l. 50 % of time and 50 % of location	E_{med} (dB μ V/m)	52	58	64	70	76
Location Probability: 99 %						
Location correction factor	C_l (dB)	13				
Minimum median power flux density at 10 m a.g.l. 50 % of time and 50 % of location	ϕ_{med} (dBW/m ²)	-87,9	-81,9	-75,9	-69,9	-63,9
Minimum median equivalent field strength at 10 m a.g.l. 50 % of time and 50 % of location	E_{med} (dB μ V/m)	58	64	70	76	82

Table 11.15: Minimum median power flux density and equivalent minimum median field strength in Band V and 90 % and 99 % location probability
Receiving condition: Mobile outdoor (Class C), Rural, Band V, terminal category 1

Frequency		f (MHz)		800				
Minimum C/N required by system		(dB)		2	8	14	20	26
Min. receiver signal input power	$P_{s \min}$ (dBW)	-127,2	-121,2	-115,2	-109,2	-103,2		
Min. equivalent receiver input voltage, 75 Ω	$U_{s \min}$ (dBW)	12	18	24	30	36		
Antenna gain relative to half dipole	U_a (dB)	-1						
Effective Antenna aperture	A_a (dBm ²)	-18,4						
Min. power flux density at receiving location	ϕ_{\min} (dBW/m ²)	-108,8	-102,8	-96,8	-90,8	-84,8		
Min. equivalent field strength at receiving location	E_{\min} (dB μ V/m)	37	43	49	55	61		
Allowance for manmade noise	P_{mmn} (dB)	0						
Height loss	L_h (dB)	13						
Location Probability: 90 %								
Location correction factor	C_l (dB)	7						
Minimum median power flux density at 10 m a.g.l. 50 % of time and 50 % of location	ϕ_{med} (dBW/m ²)	-88,8	-82,8	-76,8	-70,8	-64,8		
Minimum median equivalent field strength at 10 m a.g.l. 50 % of time and 50 % of location	E_{med} (dB μ V/m)	57	63	69	75	81		
Location Probability: 99 %								
Location correction factor	C_l (dB)	13						
Minimum median power flux density at 10 m a.g.l. 50 % of time and 50 % of location	ϕ_{med} (dBW/m ²)	-82,8	-76,8	-70,8	-64,8	-58,8		
Minimum median equivalent field strength at 10 m a.g.l. 50 % of time and 50 % of location	E_{med} (dB μ V/m)	63	69	75	81	87		

Table 11.16: Minimum median power flux density and equivalent minimum median field strength in Band IV and 90 % and 99 % location probability
Receiving condition: Mobile inside (Class D), Rural, Band IV, terminal category 3

Frequency		f (MHz)		500				
Minimum C/N required by system		(dB)		2	8	14	20	26
Min. receiver signal input power	$P_{s \min}$ (dBW)	-127,2	-121,2	-115,2	-109,2	-103,2		
Min. equivalent receiver input voltage, 75 Ω	$U_{s \min}$ (dBW)	12	18	24	30	36		
Antenna gain relative to half dipole	U_a (dB)	-12						
Effective Antenna aperture	A_a (dBm ²)	-25,3						
Min. power flux density at receiving location	ϕ_{\min} (dBW/m ²)	-101,9	-95,9	-89,9	-83,9	-77,9		
Min. equivalent field strength at receiving location	E_{\min} (dB μ V/m)	44	50	56	62	68		
Allowance for manmade noise	P_{mmn} (dB)	0						
Height loss	L_h (dB)	11						
Vehicular entry loss	L_v (dB)	7						
Location Probability: 90 %								
Location correction factor	C_l (dB)	7						
Minimum median power flux density at 10 m a.g.l. 50 % of time and 50 % of location	ϕ_{med} (dBW/m ²)	-76,9	-70,9	-64,9	-58,9	-52,9		
Minimum median equivalent field strength at 10 m a.g.l. 50 % of time and 50 % of location	E_{med} (dB μ V/m)	69	75	81	87	93		
Location Probability: 99 %								
Location correction factor	C_l (dB)	13						
Minimum median power flux density at 10 m a.g.l. 50 % of time and 50 % of location	ϕ_{med} (dBW/m ²)	-70,9	-64,9	-58,9	-52,9	-46,9		
Minimum median equivalent field strength at 10 m a.g.l. 50 % of time and 50 % of location	E_{med} (dB μ V/m)	75	81	87	93	99		

Table 11.17: Minimum median power flux density and equivalent minimum median field strength in Band V and 90 % and 99 % location probability
Receiving condition: Mobile inside (Class D), Rural, Band V, terminal category 3

Frequency	f (MHz)	800				
		2	8	14	20	26
Minimum C/N required by system						
Min. receiver signal input power	$P_{s \min}$ (dBW)	-127,2	-121,2	-115,2	-109,2	-103,2
Min. equivalent receiver input voltage, 75 Ω	$U_{s \min}$ (dBW)	12	18	24	30	36
Antenna gain relative to half dipole	U_a (dB)	-7				
Effective Antenna aperture	A_a (dBm ²)	-24,4				
Min. power flux density at receiving location	ϕ_{\min} (dBW/m ²)	-102,8	-96,8	-90,8	-84,8	-78,8
Min. equivalent field strength at receiving location	E_{\min} (dB μ V/m)	43	49	55	61	67
Allowance for manmade noise	P_{mmn} (dB)	0				
Height loss	L_h (dB)	13				
Vehicular entry loss	L_v (dB)	7				
Location Probability: 90 %						
Location correction factor	C_1 (dB)	7				
Minimum median power flux density at 10 m a.g.l. 50 % of time and 50 % of location	ϕ_{med} (dBW/m ²)	-75,8	-69,8	-63,8	-57,8	-51,8
Minimum median equivalent field strength at 10 m a.g.l. 50 % of time and 50 % of location	E_{med} (dB μ V/m)	70	76	82	88	94
Location Probability: 99 %						
Location correction factor	C_1 (dB)	13				
Minimum median power flux density at 10 m a.g.l. 50 % of time and 50 % of location	ϕ_{med} (dBW/m ²)	-69,8	-63,8	-57,8	-51,8	-45,8
Minimum median equivalent field strength at 10 m a.g.l. 50 % of time and 50 % of location	E_{med} (dB μ V/m)	76	82	88	94	100

Annex A: Terminal categories

The present document, following IEC 62002-1 [i.7], considers three different terminal categories:

- 1) **Integrated Car Terminals:**
This category covers DVB-H terminals installed in a car and where the antenna is integral with the car.
- 2) **Portable Digital TV Sets:**
This category covers terminals, which are intended for receiving digital TV services indoors and outdoors with terminal attached antennas. This category is divided to two sub-categories:
 - 2a) The receiver screen size is typically greater than 25 cm and the receiver may be battery or mains powered. Typically the terminal is stationary during the reception. An example of the antenna construction may be an adjustable telescope or wide-band design, either active or passive, attached to the receiver.
 - 2b) Pocketable digital TV-receiver. The terminal is battery operated and can be moved during use. Usually the antenna is integral with the terminal.
- 3) **Handheld Portable Convergence Terminals:**
This category covers small battery powered handheld convergence terminals with built-in cellular radio like GSM, GPRS or UMTS. The terminals have the functionality of a mobile phone and can receive IP-based services using DVB-H. The DVB-H antenna and the cellular antenna are both integral with the terminal.

Annex B: Interoperability with Cellular Radios

B.1 General issues

The following clause is based on IEC 62002-1 [i.7].

Most of the services presented for convergence terminals require the co-existence and partly simultaneous operation of DVB-H receiver and cellular radios. The cellular radio could be in Europe GMS/EDGE 900, GSM/EDGE 1 800, WCDMA or a combination of these.

The co-existence and especially simultaneous operation of several radios in small sized handheld terminal causes several challenges for the design.

Issues

The system level interoperability issues for DVB-H reception coming from the co-existence and operation of DVB-H receiver and cellular radio transmitter can be divided into two main categories:

- 1) Cellular radio uplink wanted signal interference to DVB-H receiver.
- 2) Cellular radio uplink unwanted signal interference to DVB-H receiver:
 - a) Transmitter Power Amplifier spurious responses.
 - b) Transmitter Power Amplifier (PA) noise.

It is necessary to maintain undisturbed operation of cellular radio. Possible impairments caused by DVB-H receiver could be:

- Spurious responses in cellular downlink (Rx) band.
- Affects to the cellular antenna pattern.

These problems are pure implementation issues and can be solved by proper terminal design.

Terminal Architectures

The terminal architecture (relevant parts) of a typical modern GSM/EDGE or WCDMA + DVB-H convergence terminal is presented in figure B.1.

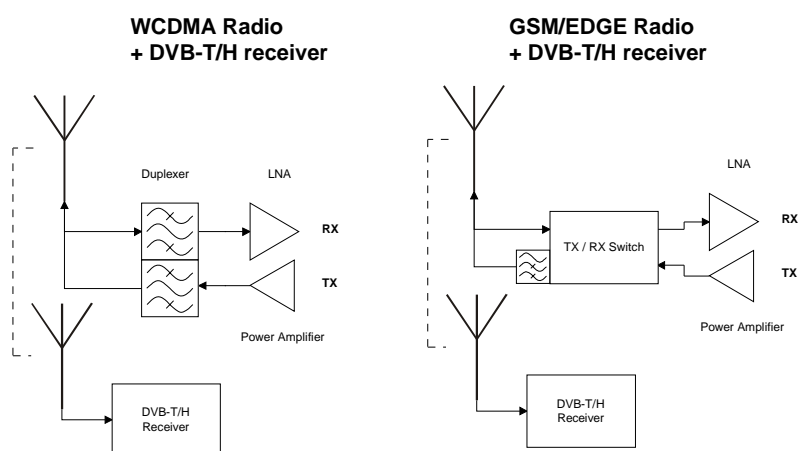

Figure B.1: Terminal architectures

Most probably DVB-H receiver and cellular radio will have two physically separate antennas, which will have frequency dependent antenna isolation between them.

An important difference between WCDMA and GSM/EDGE radios is the duplex filter. WCDMA will use duplex filter, but majority of modern GSM/EDGE radios use Tx/Rx switch. This has a major implication on the interoperability and it is obvious that the cellular radio uplink unwanted signal interference to DVB-H receiver will not be a problem in WCDMA terminal if a duplexer is used. However the problem will be severe in GSM/EDGE terminal with Tx/Rx switch.

Frequency Bands

The frequency bands used by the different radio systems are presented in figure B.2.

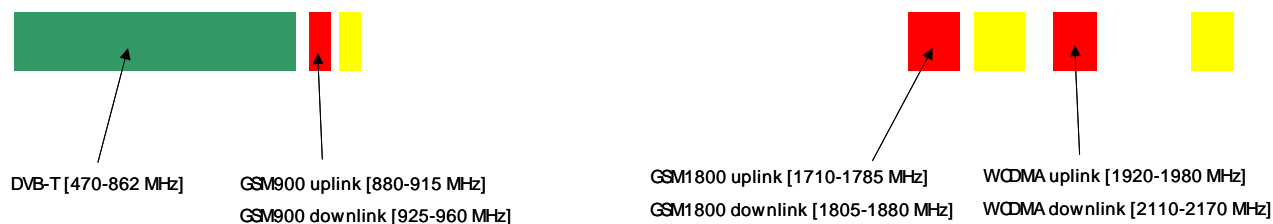

Figure B.2: Frequency bands

The full UHF DVB-H band is marked green and the uplink bands of cellular radios are marked red in the figure. This means transmitted signal (Tx) in the mobile terminal end and therefore represent by the high power level. The downlink (receiving / Rx) bands of cellular radios are marked yellow.

From the figure it is obvious that the most problematic cellular radio from interoperability point of view is the GSM 900 because of the very narrow guard band between DVB-H band and GSM 900 uplink. The guard band is only 18 MHz wide. Therefore the relative band width of the guard band is very small. The problems are much less severe with GSM 1 800 and even easier with WCDMA because of the bigger guard band between Rx and Tx-bands.

B.2 Cellular Radio Uplink Wanted Signal Interference to DVB-H Receiver

Problem area

The transmitted cellular signal is very high power compared to the received DVB-T/H signals. GSM 900 TX signal is the strongest one and therefore it will be considered here as a worst-case situation. Also the guard band is smallest between GSM 900 TX and DVB-T/H RX bands.

GSM 900 transmitted power is +33 dB(mW) (2W). Part of this is coupled from cellular transmitter antenna to the DVB-T/H receiver antenna. Optimistic assumption for the coupling loss between antennas is 10 dB. Therefore without any filtering the cellular TX signal present in the DVB-T/H receiver, input would be +23 dB(mW).

This very high interference signal level would cause severe blocking effects by two mechanisms: desensitization and cross-modulation.

Interoperability requirements

The practical solution for interoperability is to insert GSM-rejection filter in front of the DVB-T/H receiver. The filter has to attenuate the cellular Tx-signal to a level where the receiver sensitivity will drop a maximum of 1,5 dB from the specified sensitivity. It is assumed that the antenna isolation between the cellular transmitter antenna and DVB-H reception antenna is at least 15 dB. When the cellular Tx signal maximum level is 33 dB(mW), this means a level of +18 dB(mW) at the reference point in front of the GSM-reject filter.

This requirement has to be met when the cellular interferer frequency is in the frequency ranges given in table B.1.

Table B.1: Cellular interferer frequency ranges

Cellular system	Frequency [MHz]
GSM 900	880-915
GSM 1 800	1 710-1 785
WCDMA	1 920-1 980

B.3 Cellular Radio Uplink Unwanted Signal Interference to DVB-H Receiver

Transmitter power amplifier carrier like spurious responses

The GSM specification (TS 100 910 [i.12]) defines that within 100 KHz measurement bandwidth the power is not allowed to be greater than -36 dBm within frequency band 9 KHz to 1 GHz.

In practise the spectrum of the carrier like spurious responses is very sparse, and DVB-H itself is very tolerant to this kind of interference. However, the implementation of the terminal has to take care that the performance degradation is low enough at the relevant frequencies.

Transmitter Power Amplifier (PA) noise

The cellular radio transmitter emits in addition to the wanted cellular Tx signal and carrier like spurious signals also wideband noise. The circuit model of the GSM transmitter Tx branch is presented in figure B.3.

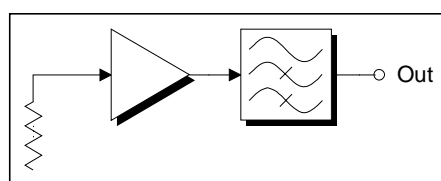

Figure B.3: GSM Tx Block Diagram

In GSM/EDGE radio where Rx/Tx switch (like in figure B.1) is used, the last high pass filter is very relaxed or nonexistent. If we assume that the filter is not implemented at all and no natural roll off zero is present, the noise power within one DVB-H channel in the power amplifier output can be calculated from the following equation. The power amplifier input is assumed to be matched to 50 Ω.

$$P_{noise} [\text{dBm}] = -174 + 10 \times \log(7,61 \times 10^6) + G[\text{dB}] + NF [\text{dB}]$$

Where:

- G = Gain of the PA, typically 20 dB
- NF = Noise figure of the PA, typically at least 15 dB

With these figures and assuming a 10 dB coupling loss between GSM and DVB-H antennas, the interference power entering DVB-H receiver would be -80 dBm. As the sensitivity of the DVB-H receiver for example with 16QAM CR = 1/2 mode is -88,9 dBm. It is obvious that the transmitter output noise reduces the DVB-H receiver sensitivity considerably.

In order to degrade DVB-H receiver sensitivity "only" by 3 dB the transmitter output noise would need to be -105 dBm within one DVB-H channel.

In practice the problem is most severe with GSM 900 band. With GSM 1 800 band natural roll-off and possible Tx high pass filter and bandwidth limitation of the power amplifier provides adequate attenuation for the DVB-H band. In WCDMA radio the problem does not exist because of the used duplex filter.

Reduction of the noise level becomes possible when the DVB-H operating band for terminal category 3 is limited to channel 55 (centre frequency 746 MHz). At 746 MHz matching of the power amplifier already provides considerable filtering i.e. the gain of the PA at 746 MHz is much reduced when compared to the gain at 880 MHz. Also possible extra filters become much easier to realize. All this gives a good possibility to drop the PA noise contribution to a negligible level in Band IV.

Interoperability requirements

To guarantee interoperability between the radio systems the noise power at the DVB-H receiver input (@ 8 MHz band) has to fulfil the mask shown in figure B.4.

The noise level is affected by the gain, noise figure and bandwidth of the power amplifier, by antenna coupling between the two antennas at the DVB-H reception band and by the attenuation of the possible high pass filter at the output of the PA.

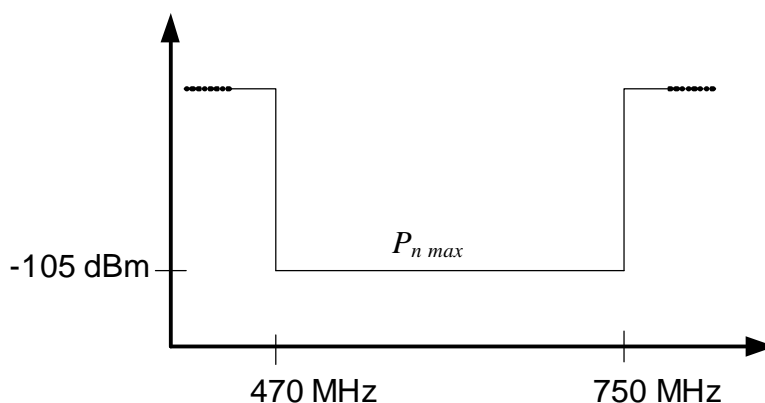

Figure B.4: Tx PA-noise Mask in DVB-H Receiver Input

B.4 Supported frequency range

In case GSM 900 is used in a convergence DVB-H terminal the usable frequency range is limited to channel 55 [746 MHz] and below due to the interoperability considerations inside the handset.

NOTE: Some operators in some countries may consider using VHF band for DVB-H services. While this is allowed by the standard, it should be noted that it may be that the terminals on the market will not support this due to antenna size/gain problems.

Annex C:

DVB-H link layer parameter selection

C.1 Introduction

In this Annex a number of concrete examples of DVB-H parameter selections are presented. The power consumption model of clause 9.1.3.2 has been used together with the following values for some of the parameters:

Available bitrate for DVB-H:

- 5 Mb/s corresponding to QPSK, CR = 1/2, GI = 1/4.
- 10 Mb/s, corresponding to 16-QAM, CR = 1/2, GI = 1/4.

The available bitrate can be used to carry one or more parallel ESs, depending on parameter values of the respective parameter set. Each ES can carry one or more services, depending on the bitrate requirements for the service.

NOTE: Concerning PSI/SI the PAT/PMT are sent continuously, but the required bitrate for this is so small (about 30 kb/s) so, for simplicity, it is simply neglected in the examples. It is assumed that SI tables (e.g. NIT, INT) will be transmitted in burst (although not in DVB-H bursts). Therefore in practice the full TS bitrate (minus capacity for PAT/PMT) is potentially available for DVB-H.

Peak ES bitrate:

- 2,5 Mb/s (2 parallel ESs in QPSK, 4 parallel ESs in 16-QAM)..
- 5 Mb/s (1 ES in QPSK, 2 parallel ESs in 16-QAM).
- 10 Mb/s (1 ES in 16-QAM).

Burst time (interleaving depth):

- 200 ms.
- 400 ms.

Interleaving depth in this range is considered adequate. Interleaving depth could have an effect on RF performance at lower speeds, although this is still to be quantified.

Burst/MPE-FEC frame size:

- 1 Mb/512 rows.
- 2 Mb/1 024 rows.

For the same interleaving depth a larger frame size should in principle result in a somewhat better C/N performance, although the difference is still to be quantified and is probably fairly small.

All the parameters cannot be varied independently but all of them will appear in one or more of the examples below.

The lock time is assumed to be always 120 ms during ongoing time slicing and total synchronization time is assumed to be < 200 ms in case of change of TS.

Cycle time is minimized, while keeping the following two requirements:

- Power consumption < 100 mW.
- $4 \times (\text{burst_time} + \text{synchronization_time}) < \text{cycle_time}$ (to allow seamless handover based on phase shifts).

The above parameters can be combined into basically four different parameter sets.

NOTE: The numbers of services per ES are just examples, other values are equally possible.

C.2 Parameter set number 1

- 1 Mb MPE-FEC frame size (512 rows).
- 400 ms burst time/interleaving depth.
- 2,5 Mb/s peak ES bitrate.
- Parallel ESs: 2 ESs fit into a 5 Mb/s TS (QPSK 1/2) or 4 ESs fit into a 10 Mb/s TS (16-QAM 1/2).

Table C.1: Parameter set 1

Burst size =	1	Mbit	Same as memory needed for 1 service
ES peak bit rate =	2,5	Mb/s	
No. of services per ES =	1		
Cycle_time =	2,500	s	
Lock_time =	0,120	s	
RF_OFF1 =	0,500	s	
RF_on [mW] =	400	mW	
RF_off1 [mW] =	50	mW	
RF_off3 [mW] =	10	mW	
ES_average_bit_rate =	400	kb/s	
Gross_service_bit_rate =	400	kb/s	
Net_service_bit_rate =	300	kb/s	Assuming MPE-FEC 3/4
Burst_time =	0,400	s	Same as interleaving depth
RF_ON =	0,520	s	
Total_off_time =	1,980	s	
Max sync time with phase shifts	0,225	s	
Average_power =	99,1	[mW]	
Power_saving =	75,2	%	

Figure C.1 depicts the configuration in QPSK network.

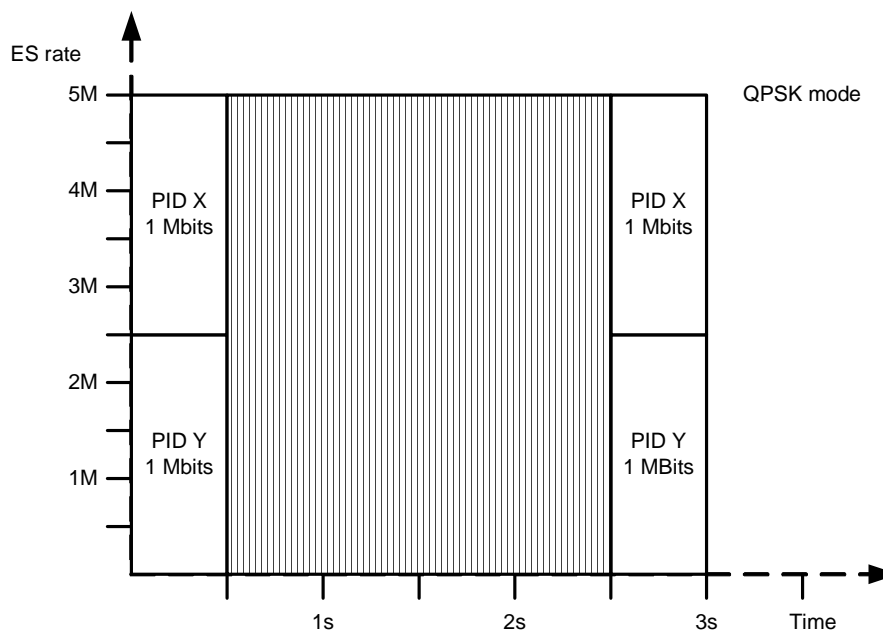

Figure C.1: Parameter set 1

C.3 Parameter set number 2

- 1 Mb MPE-FEC frame size (512 rows).
- 200 ms burst time/interleaving depth.
- 5,0 Mb/s peak ES bitrate.
- Parallel ESs: 1 ES fit into a 5 Mb/s TS (QPSK 1/2) or 2 ESs fit into a 10 Mb/s TS (16-QAM 1/2).

Table C.2: Parameter set 2

Burst size =	1	Mbit	Same as memory needed for 1 service
ES peak bit rate =	5,0	Mb/s	
No. of services per ES =	1		
Cycle_time =	1,610	s	
Lock_time =	0,120	s	
RF_OFF1 =	0,500	s	
RF_on [mW] =	400	mW	
RF_off1 [mW] =	50	mW	
RF_off3 [mW] =	10	mW	
ES_average_bit_rate =	621	kb/s	
Gross_service_bit_rate =	621	kb/s	
Net_service_bit_rate =	466	kb/s	Assuming MPE-FEC 3/4
Burst_time =	0,200	s	Same as interleaving depth
RF_ON =	0,320	s	
Total_off_time =	1,290	s	
Max sync time with phase shifts	0,203	s	
Average_power =	99,9	[mW]	
Power_saving =	75,0	%	

The following figure depicts the configuration in 16QAM network.

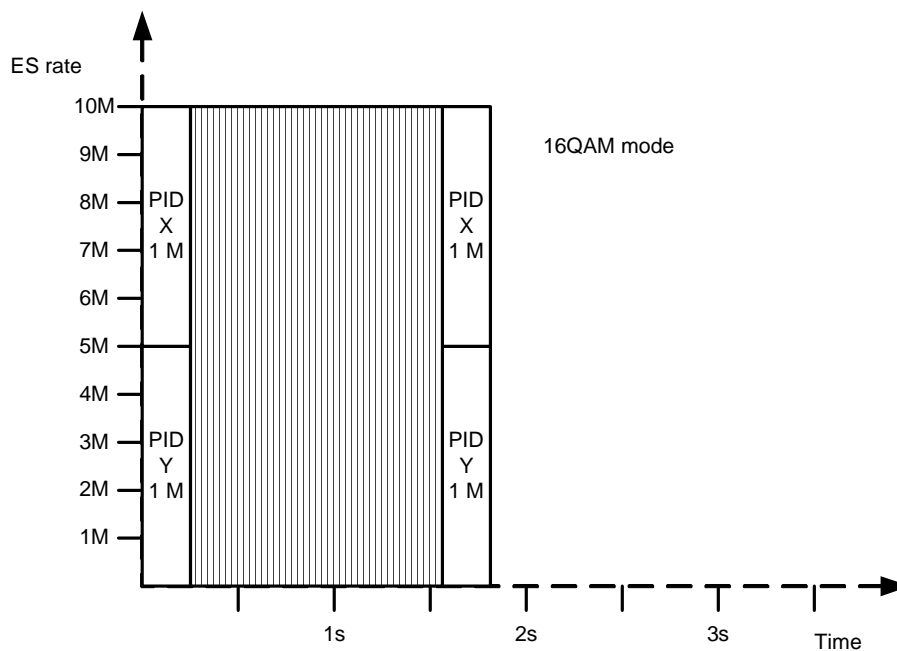

Figure C.2: Parameter set 2

C.4 Parameter set number 3

- 2 Mb MPE-FEC frame size (1 024 rows).
- 200 ms burst time/interleaving depth.
- 10 Mb/s peak ES bitrate.
- Parallel ESs: 1 ES fit into a 10 Mb/s TS (16-QAM 1/2).

Table C.3: Parameter set 3

Burst size =	2	Mbit	Same as memory needed for 1 service
ES peak bit rate =	10,0	Mb/s	
No. of services per ES =	4		
Cycle_time =	1,610	s	
Lock_time =	0,120	s	
RF_OFF1 =	0,500	s	
RF_on [mW] =	400	mW	
RF_off1 [mW] =	50	mW	
RF_off3 [mW] =	10	mW	
ES_average_bit_rate =	1242	kb/s	
Gross_service_bit_rate =	311	kb/s	
Net_service_bit_rate =	233	kb/s	Assuming MPE-FEC 3/4
Burst_time =	0,200	s	Same as interleaving depth
RF_ON =	0,320	s	
Total_off_time =	1,290	s	
Max sync time with phase shifts	0,203	s	
Average_power =	99,9	[mW]	
Power_saving =	75,0	%	

Figure C.3 depicts the configuration 16QAM network.

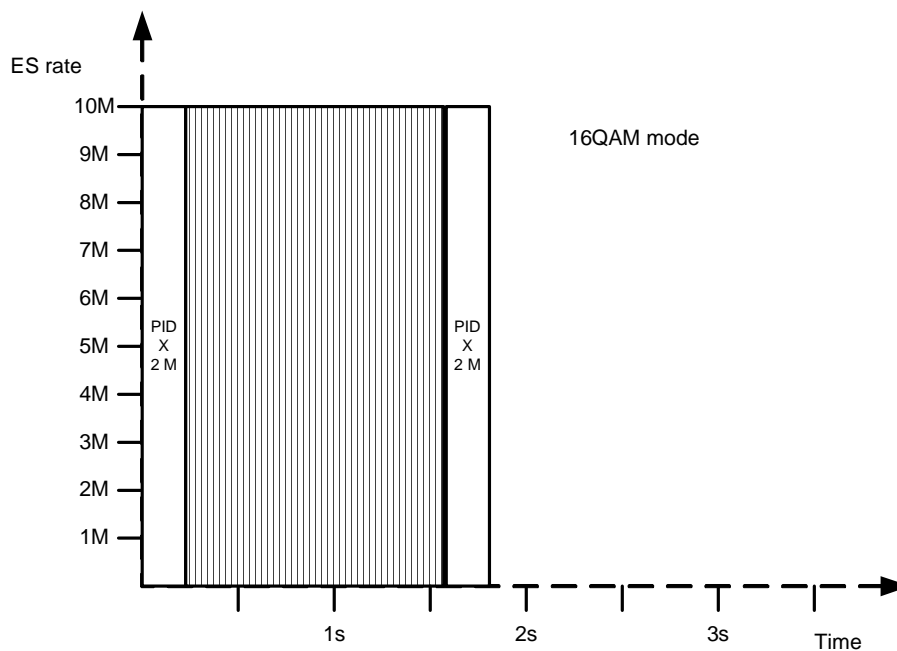

Figure C.3: Parameter set 3

C.5 Parameter set number 4

- 2 Mb MPE-FEC frame size (1 024 rows).
- 400 ms burst time/interleaving depth.
- 5 Mb/s peak ES bitrate.
- Parallel ESs: 1 ES fit into a 5 Mb/s TS (QPSK 1/2) or 2 ESs fit into a 10 Mb/s TS (16-QAM 1/2).

Table C.4: Parameter set 4

Burst size =	2	Mbit	Same as memory needed for 1 service
ES peak bit rate =	5,0	Mb/s	
No. of services per ES =	4		
Cycle_time =	2,500	s	
Lock_time =	0,120	s	
RF_OFF1 =	0,500	s	
RF_on [mW] =	400	mW	
RF_off1 [mW] =	50	mW	
RF_off3 [mW] =	10	mW	
ES_average_bit_rate =	800	kb/s	
Gross_service_bit_rate =	200	kb/s	
Net_service_bit_rate =	150	kb/s	Assuming MPE-FEC 3/4
Burst_time =	0,400	s	Same as interleaving depth
RF_ON =	0,520	s	
Total_off_time =	1,980	s	
Max sync time with phase shifts	0,225	s	
Average_power =	99,1	[mW]	
Power_saving =	75,2	%	

Figure C.4 depicts the configuration 16QAM network.

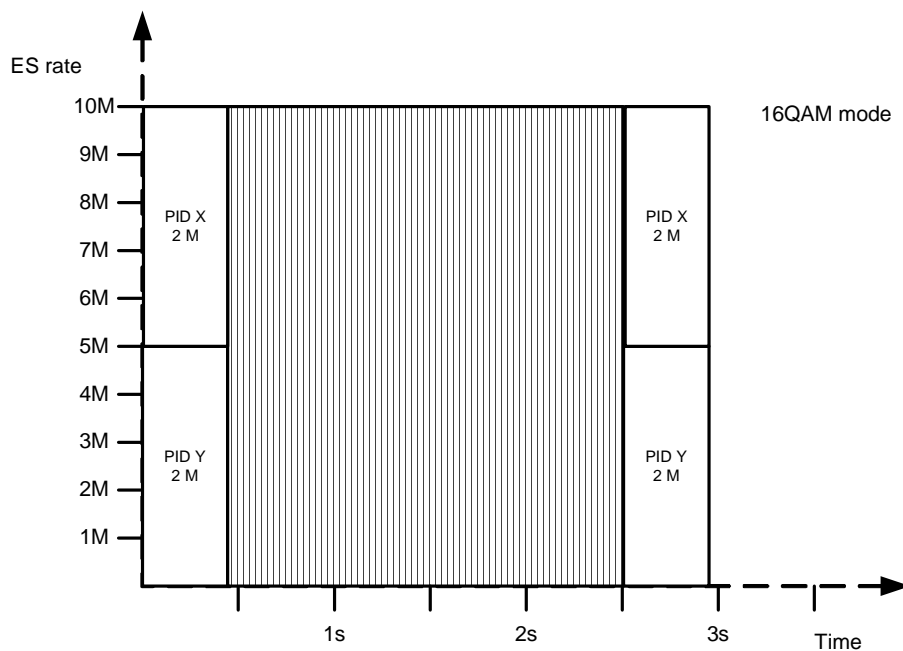

Figure C.4: Parameter set 4

Annex D: Channel models for DVB-H

D.1 Portable Indoor and Outdoor Channels (PI & PO)

The portable indoor (PI) and portable outdoor channel models have been developed by the Wing-TV project for describing the slowly moving hand held reception indoors and outdoors. The channel models are based on measurements in DVB-H Single Frequency Networks and have paths from two different transmitter locations. Definitions of the taps for the channels are given in tables D.2 and D.3. The indicated Doppler frequency of 1,69 Hz is corresponding 3 km/h velocity at 666 MHz. The Doppler spectra of various taps are defined in table D.1.

Table D.1: Doppler Spectrum Definitions for PI and PO Channels

Spectrum for the 1 st tap	Spectrum for taps 2-12
$0.1G(f;0.08f_D) + \delta(f - 0.5f_D)$	$G(f;0.08f_D)$

Where $G(f; \sigma) = \exp\left(\frac{-f^2}{2\sigma^2}\right)$.

Table D.2: Definition of PI channel

Path	Delay (μ s)	Power (dB)	Doppler Spectrum	Fd (Hz)	STD Norm.
1	0,0	0,0	See table 2	1,69	0,08
2	0,1	-6,4	Gauss	1,69	0,08
3	0,2	-10,4	Gauss	1,69	0,08
4	0,4	-13,0	Gauss	1,69	0,08
5	0,6	-13,3	Gauss	1,69	0,08
6	0,8	-13,7	Gauss	1,69	0,08
7	1,0	-16,2	Gauss	1,69	0,08
8	1,6	-15,2	Gauss	1,69	0,08
9	8,1	-14,9	Gauss	1,69	0,08
10	8,8	-16,2	Gauss	1,69	0,08
11	9,0	-11,1	Gauss	1,69	0,08
12	9,2	-11,2	Gauss	1,69	0,08

Table D.3: Definition of PO channel

Path	Delay (μ s)	Power (dB)	Doppler Spectrum	Fd (Hz)	STD Norm.
1	0,0	0,0	See table 2	1,69	0,08
2	0,2	-1,5	Gauss	1,69	0,08
3	0,6	-3,8	Gauss	1,69	0,08
4	1,0	-7,3	Gauss	1,69	0,08
5	1,4	-9,8	Gauss	1,69	0,08
6	1,8	-13,3	Gauss	1,69	0,08
7	2,3	-15,9	Gauss	1,69	0,08
8	3,4	-20,6	Gauss	1,69	0,08
9	4,5	-19,0	Gauss	1,69	0,08
10	5,0	-17,7	Gauss	1,69	0,08
11	5,3	-18,9	Gauss	1,69	0,08
12	5,7	-19,3	Gauss	1,69	0,08

D.2 Mobile Channel (TU-6)

This profile reproduces the terrestrial propagation in an urban area. It has been defined by COST 207 as a typical urban (TU6) profile and is made of 6 paths having wide dispersion in delay and relatively strong power. The profile parameters are given in table D.4. This channel profile has been proven to present fairly well the general mobile DVB-T reception by several field tests.

Table D.4: Typical Urban profile (TU6)

Tap number	Delay (us)	Power (dB)	Doppler spectrum
1	0,0	-3	Classical
2	0,2	0	Classical
3	0,5	-2	Classical
4	1,6	-6	Classical
5	2,3	-8	Classical
6	5,0	-10	Classical

Where the Classical Doppler spectrum is defined as:

$$K(f; f_D) = \frac{1}{\sqrt{1 - (f / f_D)^2}}$$

Annex E: Bibliography

ITU-R Report BS.1203-1: "Digital sound broadcasting to vehicular, portable and fixed receivers using terrestrial transmitters in the UHF/VHF bands".

Digital Television Group: D-Book: "Digital Terrestrial Television. Requirements for Interoperability, Issue 4.0".

ACTS - AC318 MOTIVATE (Deliverable 06): "Reference Receiver Model for Planning of Mobile TV Services".

CEPT/FM-PT24(04)034 Annex 3 Draft: "Planning Configurations and Reference Networks for DVB-T".

History

Document history		
V1.1.1	February 2005	Publication
V1.2.1	November 2005	Publication
V1.3.1	March 2009	Publication