

ETSI TR 128 925 V18.0.0 (2024-05)



5G;
**Study on enhancement of service based management
architecture**
(3GPP TR 28.925 version 18.0.0 Release 18)



Reference

DTR/TSGS-0528925vi00

Keywords

5G

ETSI

650 Route des Lucioles
F-06921 Sophia Antipolis Cedex - FRANCE

Tel.: +33 4 92 94 42 00 Fax: +33 4 93 65 47 16

Siret N° 348 623 562 00017 - APE 7112B
Association à but non lucratif enregistrée à la
Sous-Préfecture de Grasse (06) N° w061004871

Important notice

The present document can be downloaded from:

<https://www.etsi.org/standards-search>

The present document may be made available in electronic versions and/or in print. The content of any electronic and/or print versions of the present document shall not be modified without the prior written authorization of ETSI. In case of any existing or perceived difference in contents between such versions and/or in print, the prevailing version of an ETSI deliverable is the one made publicly available in PDF format at www.etsi.org/deliver.

Users of the present document should be aware that the document may be subject to revision or change of status.

Information on the current status of this and other ETSI documents is available at

<https://portal.etsi.org/TB/ETSIDeliverableStatus.aspx>

If you find errors in the present document, please send your comment to one of the following services:

<https://portal.etsi.org/People/CommitteeSupportStaff.aspx>

If you find a security vulnerability in the present document, please report it through our
Coordinated Vulnerability Disclosure Program:

<https://www.etsi.org/standards/coordinated-vulnerability-disclosure>

Notice of disclaimer & limitation of liability

The information provided in the present deliverable is directed solely to professionals who have the appropriate degree of experience to understand and interpret its content in accordance with generally accepted engineering or other professional standard and applicable regulations.

No recommendation as to products and services or vendors is made or should be implied.

No representation or warranty is made that this deliverable is technically accurate or sufficient or conforms to any law and/or governmental rule and/or regulation and further, no representation or warranty is made of merchantability or fitness for any particular purpose or against infringement of intellectual property rights.

In no event shall ETSI be held liable for loss of profits or any other incidental or consequential damages.

Any software contained in this deliverable is provided "AS IS" with no warranties, express or implied, including but not limited to, the warranties of merchantability, fitness for a particular purpose and non-infringement of intellectual property rights and ETSI shall not be held liable in any event for any damages whatsoever (including, without limitation, damages for loss of profits, business interruption, loss of information, or any other pecuniary loss) arising out of or related to the use of or inability to use the software.

Copyright Notification

No part may be reproduced or utilized in any form or by any means, electronic or mechanical, including photocopying and microfilm except as authorized by written permission of ETSI.

The content of the PDF version shall not be modified without the written authorization of ETSI.

The copyright and the foregoing restriction extend to reproduction in all media.

© ETSI 2024.
All rights reserved.

Intellectual Property Rights

Essential patents

IPRs essential or potentially essential to normative deliverables may have been declared to ETSI. The declarations pertaining to these essential IPRs, if any, are publicly available for **ETSI members and non-members**, and can be found in ETSI SR 000 314: "*Intellectual Property Rights (IPRs); Essential, or potentially Essential, IPRs notified to ETSI in respect of ETSI standards*", which is available from the ETSI Secretariat. Latest updates are available on the ETSI Web server (<https://ipr.etsi.org/>).

Pursuant to the ETSI Directives including the ETSI IPR Policy, no investigation regarding the essentiality of IPRs, including IPR searches, has been carried out by ETSI. No guarantee can be given as to the existence of other IPRs not referenced in ETSI SR 000 314 (or the updates on the ETSI Web server) which are, or may be, or may become, essential to the present document.

Trademarks

The present document may include trademarks and/or tradenames which are asserted and/or registered by their owners. ETSI claims no ownership of these except for any which are indicated as being the property of ETSI, and conveys no right to use or reproduce any trademark and/or tradename. Mention of those trademarks in the present document does not constitute an endorsement by ETSI of products, services or organizations associated with those trademarks.

DECT™, **PLUGTESTS™**, **UMTS™** and the ETSI logo are trademarks of ETSI registered for the benefit of its Members. **3GPP™** and **LTE™** are trademarks of ETSI registered for the benefit of its Members and of the 3GPP Organizational Partners. **oneM2M™** logo is a trademark of ETSI registered for the benefit of its Members and of the oneM2M Partners. **GSM®** and the GSM logo are trademarks registered and owned by the GSM Association.

Legal Notice

This Technical Report (TR) has been produced by ETSI 3rd Generation Partnership Project (3GPP).

The present document may refer to technical specifications or reports using their 3GPP identities. These shall be interpreted as being references to the corresponding ETSI deliverables.

The cross reference between 3GPP and ETSI identities can be found under <https://webapp.etsi.org/key/queryform.asp>.

Modal verbs terminology

In the present document "**should**", "**should not**", "**may**", "**need not**", "**will**", "**will not**", "**can**" and "**cannot**" are to be interpreted as described in clause 3.2 of the [ETSI Drafting Rules](#) (Verbal forms for the expression of provisions).

"**must**" and "**must not**" are **NOT** allowed in ETSI deliverables except when used in direct citation.

Contents

Intellectual Property Rights	2
Legal Notice	2
Modal verbs terminology.....	2
Foreword.....	6
1 Scope	8
2 References	8
3 Definitions of terms, symbols and abbreviations	14
3.1 Terms.....	14
3.2 Symbols.....	14
3.3 Abbreviations	14
4 Issue investigations and potential issue solutions	14
4.1 Issue #1: Scope of specifications.....	14
4.1.1 Description.....	14
4.1.1.1 3GPP TS 28.533.....	14
4.1.1.2 3GPP TS 28.621.....	15
4.1.1.3 3GPP TS 28.622.....	15
4.1.1.4 3GPP TS 28.623.....	15
4.1.1.5 3GPP TS 28.662.....	16
4.1.2 Potential solutions.....	16
4.1.2.1 Solution #1-1 scope of 3GPP TS 28.533.....	16
4.1.2.2 Solution #1-2 SBMA for Generic NRM	16
4.1.2.2.1 3GPP TS 28.621	16
4.1.2.2.1.1 Solution #1-2.a Update 3GPP TS 28.621.....	16
4.1.2.2.1.2 Solution #1-2.b New TS for SBMA.....	16
4.1.2.2.1.3 Solution #1-2.c New TSs for IRP and SBMA	16
4.1.2.2.1.4 Solution #1-2.d update 3GPP TS 28.621 scope	16
4.1.2.2.1.5 Solution #1-2.e Merge stage 1, 2 and 3.....	16
4.1.2.2.2 3GPP TS 28.622	16
4.1.2.2.2.1 Solution #1-2.f update 3GPP TS 28.622.....	16
4.1.2.2.2.2 Solution #1-2.g New TS for SBMA.....	17
4.1.2.2.2.3 Solution #1-2.h New TSs for IRP and SBMA	17
4.1.2.2.2.4 Solution #1-2.i update 3GPP TS 28.622 scope	17
4.1.2.2.2.5 Solution #1-2.j Merge stage 1, 2 and 3.	17
4.1.2.2.3 3GPP TS 28.623	17
4.1.2.2.3.1 Solution #1-2.k update 3GPP TS 28.623	17
4.1.2.2.3.2 Solution #1-2.l New TS for SBMA	17
4.1.2.2.3.3 Solution #1-2.m New TSs for IRP and SBMA	17
4.1.2.2.3.4 Solution #1-2.n update 3GPP TS 28.623 scope	17
4.1.2.2.3.5 Solution #1-2.o Merge stage 1, 2 and 3.	17
4.1.2.4 Solution #1-4 new SBMA TS for Generic RAN NRM.....	18
4.2 Issue #2: Content errors.....	18
4.2.1 Description.....	18
4.2.2 Potential solutions.....	18
4.2.2.1 Solution #2-1 3GPP specific information in TSs classified as generic	18
4.2.2.2 Solution #2-2 for stage 1 content in stage 2 3GPP TS 28.533	18
4.3 Issue #3: Reference errors	18
4.3.1 Description.....	18
4.3.2 Potential solutions.....	19
4.3.2.1 Solution #3-1 Make not used references void	19
4.4 Issue #4: SBMA supporting management of 5G SA and NSA scenarios	19
4.4.1 Description.....	19
4.4.1.1 Analysis of the existing specification capabilities.....	19
4.4.1.2 Management support for NG-RAN Overall Architecture	19
4.4.1.3 Management support for EN-DC Overall Architecture	21

4.4.2	Potential solutions #4-1	22
4.5	Issue #5: SBMA supporting management architecture and frameworks in other SDOs	23
4.5.1	Description.....	23
4.5.2	Potential solutions.....	23
4.5.2.1	ETSI ISG ZSM.....	23
4.5.2.1.1	Introduction	23
4.5.2.1.2	Potential solutions #5-1	24
4.6	Issue #6: Software management feature in SBMA for 5G	24
4.6.1	Description.....	24
4.6.2	Potential solutions.....	24
4.7	Issue #7: Inventory missing in 5G.....	24
4.7.1	Description.....	24
4.7.2	Potential solutions.....	24
4.8	Issue #8: Use of Models in SBMA.....	24
4.8.1	Description.....	24
4.8.2	Potential solutions.....	25
4.9	Issue #9: Improvement on the management function description	28
4.9.1	Description.....	28
4.9.2	Potential solutions.....	29
4.9.2.1	Management function description	29
4.9.2.2	Usage of CRUD operations and NRM fragment in SBMA	29
4.9.2.3	Notifications supported by management sets in SBMA.....	30
4.10	Issue #10: Use of 32.401 in SBMA.....	31
4.10.1	Description.....	31
4.10.2	Potential solutions.....	31
4.11	Issue #11: Use of 32.404 in SBMA.....	31
4.11.1	Description.....	31
4.11.2	Potential solutions.....	31
4.12	Issue#12: illustration of using MnS in management reference model in TS 32.101	31
4.12.1	Description.....	31
4.12.2	Potential solutions.....	33
4.13	Issue #13: Analysis on IRP specification needs to support SBMA	33
4.13.1	Description.....	33
4.13.2	Potential solutions.....	35
4.14	Issue #14: Providing a usage guide for SBMA series of specifications	38
4.14.1	Description.....	38
4.14.2	Potential solutions.....	38
4.15	Issue# 15: Extend 3GPP TS 32.300 to support SBMA	38
4.15.1	Description.....	38
4.15.2	Potential solutions.....	38
5	Conclusion and Recommendation.....	38
5.1	Issue #1 Scope of specifications.....	38
5.1.1	Solution #1-1 scope of 3GPP TS 28.533.....	38
5.1.2	Solution #1-2 SBMA for Generic NRM.....	39
5.1.2.1	Issue #1-2.a: No requirements specification generic NRM for SBMA	39
5.1.2.2	Issue #1-2.b: Scope of 3GPP 3GPP TS 28.622.....	39
5.1.2.3	Issue #1.2.c: No clear solution set definition for generic NRM in SBMA	39
5.1.3	Solution #1-3 scope of referred 3GPP TSs in 3GPP TS 28.533.....	39
5.1.4	Solution #1-4 new SBMA TS for Generic RAN NRM	39
5.2	Issue #2 Content errors.....	39
5.3	Issue #3 Reference errors	39
5.3.1	Solution #3-1 Make not used references void	39
5.4	Issue #4 SBMA supporting management of 5G SA and NSA scenarios	39
5.5	Issue #5: SBMA supporting management architecture and frameworks in other SDOs	40
5.6	Issue #6: Software management feature in SBMA for 5G	40
5.7	Issue #7 Inventory missing in 5G.....	40
5.8	Issue #8: Use of Models in SBMA.....	40
5.9	Issue #9: Improvement on the management function description	40
5.10	Issue #10: Use of 3GPP TS 32.401 in SBMA.....	40
5.11	Issue #11: Use of 3GPP TS 32.404 in SBMA.....	40
5.12	Issue#12: illustration of using MnS in management reference model in 3GPP TS 32.101	40

5.13 Issue #13: Analysis on management features for SBMA support41
5.14 Issue #14: Providing overview for SBMA series of specifications42
Annex A: Change history43
History44

Foreword

This Technical Report has been produced by the 3rd Generation Partnership Project (3GPP).

The contents of the present document are subject to continuing work within the TSG and may change following formal TSG approval. Should the TSG modify the contents of the present document, it will be re-released by the TSG with an identifying change of release date and an increase in version number as follows:

Version x.y.z

where:

- x the first digit:
 - 1 presented to TSG for information;
 - 2 presented to TSG for approval;
 - 3 or greater indicates TSG approved document under change control.
- y the second digit is incremented for all changes of substance, i.e. technical enhancements, corrections, updates, etc.
- z the third digit is incremented when editorial only changes have been incorporated in the document.

In the present document, modal verbs have the following meanings:

- shall** indicates a mandatory requirement to do something
- shall not** indicates an interdiction (prohibition) to do something

The constructions "shall" and "shall not" are confined to the context of normative provisions, and do not appear in Technical Reports.

The constructions "must" and "must not" are not used as substitutes for "shall" and "shall not". Their use is avoided insofar as possible, and they are not used in a normative context except in a direct citation from an external, referenced, non-3GPP document, or so as to maintain continuity of style when extending or modifying the provisions of such a referenced document.

- should** indicates a recommendation to do something
- should not** indicates a recommendation not to do something
- may** indicates permission to do something
- need not** indicates permission not to do something

The construction "may not" is ambiguous and is not used in normative elements. The unambiguous constructions "might not" or "shall not" are used instead, depending upon the meaning intended.

- can** indicates that something is possible
- cannot** indicates that something is impossible

The constructions "can" and "cannot" are not substitutes for "may" and "need not".

- will** indicates that something is certain or expected to happen as a result of action taken by an agency the behaviour of which is outside the scope of the present document
- will not** indicates that something is certain or expected not to happen as a result of action taken by an agency the behaviour of which is outside the scope of the present document
- might** indicates a likelihood that something will happen as a result of action taken by some agency the behaviour of which is outside the scope of the present document

might not indicates a likelihood that something will not happen as a result of action taken by some agency the behaviour of which is outside the scope of the present document

In addition:

is (or any other verb in the indicative mood) indicates a statement of fact

is not (or any other negative verb in the indicative mood) indicates a statement of fact

The constructions "is" and "is not" do not indicate requirements.

1 Scope

The present document studies on the potential enhancement of service based management architecture based on the existing 5G service based management architecture.

2 References

The following documents contain provisions which, through reference in this text, constitute provisions of the present document.

- References are either specific (identified by date of publication, edition number, version number, etc.) or non-specific.
- For a specific reference, subsequent revisions do not apply.
- For a non-specific reference, the latest version applies. In the case of a reference to a 3GPP document (including a GSM document), a non-specific reference implicitly refers to the latest version of that document *in the same Release as the present document*.

- [1] 3GPP TR 21.905: "Vocabulary for 3GPP Specifications".
- [2] 3GPP TS 28.533: "Management and orchestration; Architecture framework".
- [3] 3GPP TS 32.101: "Telecommunication management; Principles and high level requirements".
- [4] 3GPP TS 38.300: "NR; NR and NG-RAN Overall Description; Stage 2".
- [5] 3GPP TS 37.340: "Evolved Universal Terrestrial Radio Access (E-UTRA) and NR; Multi-connectivity; Stage 2".
- [6] ETSI GS ZSM 002: "Zero-touch network and Service Management (ZSM); Reference Architecture".
- [7] 3GPP TS 28.510: "Telecommunication management; Configuration Management (CM) for mobile networks that include virtualized network functions; Requirements".
- [8] 3GPP TS 28.511: "Telecommunication management; Configuration Management (CM) for mobile networks that include virtualized network functions; Procedures".
- [9] 3GPP TS 28.512: "Telecommunication management; Configuration Management (CM) for mobile networks that include virtualized network functions; Stage 2".
- [10] 3GPP TS 28.513: "Telecommunication management; Configuration Management (CM) for mobile networks that include virtualized network functions; Stage 3".
- [11] 3GPP TS 28.515: "Telecommunication management; Fault Management (FM) for mobile networks that include virtualized network functions; Requirements".
- [12] 3GPP TS 28.516: "Telecommunication management; Fault Management (FM) for mobile networks that include virtualized network functions; Procedures".
- [13] 3GPP TS 28.517: "Telecommunication management; Fault Management (FM) for mobile networks that include virtualized network functions; Stage 2".
- [14] 3GPP TS 28.518: "Telecommunication management; Fault Management (FM) for mobile networks that include virtualized network functions; Stage 3".
- [15] 3GPP TS 28.520: "Telecommunication management; Performance Management (PM) for mobile networks that include virtualized network functions; Requirements".
- [16] 3GPP TS 28.521: "Telecommunication management; Performance Management (PM) for mobile networks that include virtualized network functions; Procedures".

- [17] 3GPP TS 28.522: "Telecommunication management; Performance Management (PM) for mobile networks that include virtualized network functions; Stage 2".
- [18] 3GPP TS 28.523: "Telecommunication management; Performance Management (PM) for mobile networks that include virtualized network functions; Stage 3".
- [19] 3GPP TS 28.525: "Telecommunication management; Life Cycle Management (LCM) for mobile networks that include virtualized network functions; Requirements".
- [20] 3GPP TS 28.526: "Telecommunication management; Life Cycle Management (LCM) for mobile networks that include virtualized network functions; Procedures".
- [21] 3GPP TS 28.527: "Telecommunication management; Life Cycle Management (LCM) for mobile networks that include virtualized network functions; Stage 2".
- [22] 3GPP TS 28.528: "Telecommunication management; Life Cycle Management (LCM) for mobile networks that include virtualized network functions; Stage 3".
- [23] 3GPP TS 28.622: "Telecommunication management; Generic Network Resource Model (NRM) Integration Reference Point (IRP); Information Service (IS)".
- [24] 3GPP TS 32.103: "Telecommunication management; Integration Reference Point (IRP) overview and usage guide".
- [25] 3GPP TS 28.537: "Management and orchestration; Management capabilities".
- [26] 3GPP TS 32.425: "Telecommunication management; Performance Management (PM); Performance measurements Evolved Universal Terrestrial Radio Access Network (E-UTRAN)".
- [27] 3GPP TS 28.552: "Management and orchestration; 5G performance measurements".
- [28] 3GPP TS 28.500: "Telecommunication management; Management concept, architecture and requirements for mobile networks that include virtualized network functions".
- [29] 3GPP TS 32.111-2: "Telecommunication management; Fault Management; Part 2: Alarm Integration Reference Point (IRP); Information Service (IS)".
- [30] 3GPP TS 32.662: "Telecommunication management; Configuration Management (CM); Kernel CM Information Service (IS)".
- [31] 3GPP TS 32.531: "Telecommunication management; Software management (SwM); Concepts and Integration Reference Point (IRP) Requirements".
- [32] 3GPP TS 32.532: "Telecommunication management; Software management (SwM); Integration Reference Point (IRP); Information Service (IS)".
- [33] 3GPP TS 32.533: "Telecommunication management; Software management (SwM); Integration Reference Point (IRP); Common Object Request Broker Architecture (CORBA) Solution Set (SS)".
- [34] 3GPP TS 28.631: "Telecommunication management; Inventory Management (IM) Network Resource Model (NRM) Integration Reference Point (IRP); Requirements".
- [35] 3GPP TS 28.632: "Telecommunication management; Inventory Management (IM) Network Resource Model (NRM) Integration Reference Point (IRP); Information Service (IS)".
- [36] 3GPP TS 28.633: "Telecommunication management; Inventory Management (IM) Network Resource Model (NRM) Integration Reference Point (IRP); Solution Set (SS) definitions".
- [37] 3GPP TS 32.156 "Telecommunication management; Fixed Mobile Convergence (FMC); Model repertoire".
- [38] 3GPP TS 32.401: "Telecommunication management; Performance Management (PM); Concept and requirements".

- [39] 3GPP TS 32.404: "Telecommunication management; Performance Management (PM); Performance measurements; Definitions and template".
- [40] 3GPP TS 25.331: "Radio Resource Control (RRC); Protocol specification".
- [41] 3GPP TS 25.433 "UTRAN Iub interface Node B Application Part (NBAP) signalling".
- [42] 3GPP TS 32.300: "Telecommunication management; Configuration Management (CM); Name convention for Managed Objects".
- [43] 3GPP TS 28.621: "Telecommunication management; Generic Network Resource Model (NRM) Integration Reference Point (IRP); Requirements".
- [44] 3GPP TS 28.623: "Telecommunication management; Generic Network Resource Model (NRM) Integration Reference Point (IRP); Solution Set (SS) definitions".
- [45] 3GPP TS 28.532: "Management and orchestration; Generic management services".
- [46] 3GPP TS 28.541: "Management and orchestration; 5G Network Resource Model (NRM); Stage 2 and stage 3".
- [47] 3GPP TS 28.104: "Management and orchestration; Management Data Analytics (MDA)".
- [48] 3GPP TS 28.105: "Management and orchestration; Artificial Intelligence/Machine Learning (AI/ML) management".
- [49] 3GPP TS 28.536: "Management and orchestration; Management services for communication service assurance; Stage 2 and stage 3".
- [50] 3GPP TS 28.312: "Management and orchestration; Intent driven management services for mobile networks".
- [51] 3GPP TS 28.538: "Management and orchestration; Edge Computing Management".
- [52] 3GPP TS 28.662: "Telecommunication management; Generic Radio Access Network (RAN) Network Resource Model (NRM) Integration Reference Point (IRP); Information Service (IS)".
- [53] 3GPP TS 23.501: "System architecture for the 5G System (5GS)".
- [54] 3GPP TS 28.545: "Management and orchestration; Fault Supervision (FS)".
- [55] 3GPP TS 28.550: "Management and orchestration; Performance assurance".
- [56] 3GPP TS 28.314: "Management and orchestration; Plug and Connect; Concepts and requirements".
- [57] 3GPP TS 28.315: "Management and orchestration; Plug and Connect; Procedure flows".
- [58] 3GPP TS 28.316: "Management and orchestration; Plug and Connect; Data formats".
- [59] 3GPP TS 28.530: "Management and orchestration; Concepts, use cases and requirements".
- [60] 3GPP TS 28.100: "Management and orchestration; Levels of autonomous network".
- [61] 3GPP TS 28.531: "Management and orchestration; Provisioning".
- [62] 3GPP TS 28.310: "Management and orchestration; Energy efficiency of 5G".
- [63] 3GPP TS 28.313: "Management and orchestration; Self-Organizing Networks (SON) for 5G networks".
- [64] 3GPP TS 32.421: "Telecommunication management; Subscriber and equipment trace; Trace concepts and requirements".
- [65] 3GPP TS 32.422: "Telecommunication management; Subscriber and equipment trace; Trace control and configuration management".

- [66] 3GPP TS 32.423: "Telecommunication management; Subscriber and equipment trace; Trace data definition and management".
- [67] 3GPP TS 28.404: "Telecommunication management; Quality of Experience (QoE) measurement collection; Concepts, use cases and requirements".
- [68] 3GPP TS 28.405: "Telecommunication management; Quality of Experience (QoE) measurement collection; Control and configuration".
- [69] 3GPP TS 32.130: "Telecommunication management; Network sharing; Concepts and requirements".
- [70] 3GPP TS 28.555: "Management and orchestration; Network policy management for 5G mobile networks; Stage 1".
- [71] 3GPP TS 28.556: "Management and orchestration; Network policy management for 5G mobile networks; Stage 2 and stage 3".
- [72] 3GPP TS 28.535: "Management and orchestration; Management services for communication service assurance; Requirements".
- [73] 3GPP TS 28.557: "Management and orchestration; Management of Non-Public Networks (NPN); Stage 1 and stage 2".
- [74] 3GPP TS 28.540: "Management and orchestration; 5G Network Resource Model (NRM); Stage 1".
- [75] 3GPP TS 28.554: "Management and orchestration; 5G end to end Key Performance Indicators (KPI)".
- [76] IETF RFC 7950: "The YANG 1.1 Data Modeling Language".
- [77] IETF RFC 6241: "Network Configuration Protocol (NETCONF)".
- [78] 3GPP TS 32.301: "Telecommunication management; Configuration Management (CM); Notification Integration Reference Point (IRP); Requirements".
- [79] 3GPP TS 32.302: "Telecommunication management; Configuration Management (CM); Notification Integration Reference Point (IRP); Information Service (IS)".
- [80] 3GPP TS 32.306: "Telecommunication management; Configuration Management (CM); Notification Integration Reference Point (IRP): Solution Set (SS) definitions".
- [81] 3GPP TS 28.625: "Telecommunication management; State management data definition Integration Reference Point (IRP); Information Service (IS)".
- [82] 3GPP TS 28.620: Telecommunication management; Fixed Mobile Convergence (FMC) Federated Network Information Model (FNIM) Umbrella Information Model (UIM)".
- [83] 3GPP TS 28.661: "Telecommunication management; Generic Radio Access Network (RAN) Network Resource Model (NRM) Integration Reference Point (IRP); Requirements".
- [84] 3GPP TS 28.663: "Telecommunication management; Generic Radio Access Network (RAN) Network Resource Model (NRM) Integration Reference Point (IRP); Solution Set (SS) definitions".
- [85] 3GPP TS 28.651: "Telecommunication management; Universal Terrestrial Radio Access Network (UTRAN) Network Resource Model (NRM) Integration Reference Point (IRP); Requirements".
- [86] 3GPP TS 28.652: "Telecommunication management; Universal Terrestrial Radio Access Network (UTRAN) Network Resource Model (NRM) Integration Reference Point (IRP); Information Service (IS)".
- [87] 3GPP TS 28.653: "Telecommunication management; Universal Terrestrial Radio Access Network (UTRAN) Network Resource Model (NRM) Integration Reference Point (IRP); Solution Set (SS) definitions".

- [88] 3GPP TS 28.654: "Telecommunication management; GSM/EDGE Radio Access Network (GERAN) Network Resource Model (NRM) Integration Reference Point (IRP); Requirements".
- [89] 3GPP TS 28.655: "Telecommunication management; GSM/EDGE Radio Access Network (GERAN) Network Resource Model (NRM) Integration Reference Point (IRP); Information Service (IS)".
- [90] 3GPP TS 28.656: "Telecommunication management; GSM/EDGE Radio Access Network (GERAN) Network Resource Model (NRM) Integration Reference Point (IRP); Solution Set (SS) definitions".
- [91] 3GPP TS 28.657: "Telecommunication management; Evolved Universal Terrestrial Radio Access Network (E-UTRAN) Network Resource Model (NRM) Integration Reference Point (IRP); Requirements".
- [92] 3GPP TS 28.658: "Telecommunication management; Evolved Universal Terrestrial Radio Access Network (E-UTRAN) Network Resource Model (NRM) Integration Reference Point (IRP); Information Service (IS)".
- [93] 3GPP TS 28.659: "Telecommunication management; Evolved Universal Terrestrial Radio Access Network (E-UTRAN) Network Resource Model (NRM) Integration Reference Point (IRP); Solution Set (SS) definitions".
- [94] 3GPP TS 28.701: "Telecommunication management; Core Network (CN) Network Resource Model (NRM) Integration Reference Point (IRP); Requirements".
- [95] 3GPP TS 28.702: "Telecommunication management; Core Network (CN) Network Resource Model (NRM) Integration Reference Point (IRP); Information Service (IS)".
- [96] 3GPP TS 28.703: "Telecommunication management; Core Network (CN) Network Resource Model (NRM) Integration Reference Point (IRP); Solution Set (SS) definitions".
- [97] 3GPP TS 28.704: "Telecommunication management; IP Multimedia Subsystem (IMS) Network Resource Model (NRM) Integration Reference Point (IRP); Requirements".
- [98] 3GPP TS 28.705: "Telecommunication management; IP Multimedia Subsystem (IMS) Network Resource Model (NRM) Integration Reference Point (IRP); Information Service (IS)".
- [99] 3GPP TS 28.706: "Telecommunication management; IP Multimedia Subsystem (IMS) Network Resource Model (NRM) Integration Reference Point (IRP); Solution Set (SS) definitions".
- [100] 3GPP TS 28.707: "Telecommunication management; Evolved Packet Core (EPC) Network Resource Model (NRM) Integration Reference Point (IRP); Requirements".
- [101] 3GPP TS 28.708: "Telecommunication management; Evolved Packet Core (EPC) Network Resource Model (NRM) Integration Reference Point (IRP); Information Service (IS)".
- [102] 3GPP TS 28.709: "Telecommunication management; Evolved Packet Core (EPC) Network Resource Model (NRM) Integration Reference Point (IRP); Solution Set (SS) definitions".
- [103] 3GPP TS 28.671: "Telecommunication management; Home Node B (HNB) Subsystem (HNS) Network Resource Model (NRM) Integration Reference Point (IRP); Requirements".
- [104] 3GPP TS 28.672: "Telecommunication management; Home Node B (HNB) Subsystem (HNS) Network Resource Model (NRM) Integration Reference Point (IRP); Information Service (IS)".
- [105] 3GPP TS 28.673: "Telecommunication management; Home Node B (HNB) Subsystem (HNS) Network Resource Model (NRM) Integration Reference Point (IRP); Solution Set (SS) definitions".
- [106] 3GPP TS 28.674: "Telecommunication management; Home enhanced Node B (HeNB) Subsystem (HeNS) Network Resource Model (NRM) Integration Reference Point (IRP); Requirements".
- [107] 3GPP TS 28.675: "Telecommunication management; Home enhanced Node B (HeNB) Subsystem (HeNS) Network Resource Model (NRM) Integration Reference Point (IRP); Information Service (IS)".

- [108] 3GPP TS 28.676: "Telecommunication management; Home enhanced Node B (HeNB) Subsystem (HeNS) Network Resource Model (NRM) Integration Reference Point (IRP); Solution Set (SS) definitions".
- [109] 3GPP TS 28.751: "Telecommunication management; Home enhanced Node B (HeNB) Subsystem (HeNS) Network Resource Model (NRM) Integration Reference Point (IRP); Solution Set (SS) definitions".
- [110] 3GPP TS 28.752: "Telecommunication management; Subscription Management (SuM) Network Resource Model (NRM) Integration Reference Point (IRP); Information Service (IS)".
- [111] 3GPP TS 28.753: "Telecommunication management; Subscription Management (SuM) Network Resource Model (NRM) Integration Reference Point (IRP); Solution Set (SS) definitions".
- [112] 3GPP TS 28.731: "Telecommunication management; Transport Network (TN) interface Network Resource Model (NRM) Integration Reference Point (IRP); Requirements".
- [113] 3GPP TS 28.732: "Telecommunication management; Transport Network (TN) interface Network Resource Model (NRM) Integration Reference Point (IRP); Information Service (IS)".
- [114] 3GPP TS 28.733: "Telecommunication management; Transport Network (TN) interface Network Resource Model (NRM) Integration Reference Point (IRP); Information Service (IS)".
- [115] 3GPP TS 28.734: "Telecommunication management; Signalling Transport Network (STN) interface Network Resource Model (NRM) Integration Reference Point (IRP); Requirements".
- [116] 3GPP TS 28.735: "Telecommunication management; Signalling Transport Network (STN) interface Network Resource Model (NRM) Integration Reference Point (IRP); Requirements".
- [117] 3GPP TS 28.736: "Telecommunication management; Signalling Transport Network (STN) interface Network Resource Model (NRM) Integration Reference Point (IRP); Solution Set (SS) definitions".
- [118] 3GPP TS 28.624: "Telecommunication management; State management data definition Integration Reference Point (IRP); Requirements".
- [119] 3GPP TS 28.625: "Telecommunication management; State management data definition Integration Reference Point (IRP); Requirements".
- [120] 3GPP TS 28.627: "Telecommunication management; State management data definition Integration Reference Point (IRP); Requirements".
- [121] 3GPP TS 28.628: "Telecommunication management; Self-Organizing Networks (SON) Policy Network Resource Model (NRM) Integration Reference Point (IRP); Information Service (IS)".
- [122] 3GPP TS 28.629: "Telecommunication management; Self-Organizing Networks (SON) Policy Network Resource Model (NRM) Integration Reference Point (IRP); Information Service (IS)".
- [123] 3GPP TS 28.611: "Telecommunication management; Evolved Packet Core (EPC) and non-3GPP access interworking system Network Resource Model (NRM) Integration Reference Point (IRP); Requirements".
- [124] 3GPP TS 28.612: "Telecommunication management; Evolved Packet Core (EPC) and non-3GPP access interworking system Network Resource Model (NRM) Integration Reference Point (IRP); Information Service (IS)".
- [125] 3GPP TS 28.616: "Telecommunication management; Evolved Packet Core (EPC) and non-3GPP access interworking system Network Resource Model (NRM) Integration Reference Point (IRP); Solution Set (SS) definitions".
- [126] 3GPP TS 28.681: "Telecommunication management; Wireless Local Area Network (WLAN) Network Resource Model (NRM) Integration Reference Point (IRP); Requirements".
- [127] 3GPP TS 28.682: "Telecommunication management; Wireless Local Area Network (WLAN) Network Resource Model (NRM) Integration Reference Point (IRP); Information Service (IS)".

- [128] 3GPP TS 28.683: "Telecommunication management; Wireless Local Area Network (WLAN) Network Resource Model (NRM) Integration Reference Point (IRP); Solution Set (SS) definitions".

3 Definitions of terms, symbols and abbreviations

3.1 Terms

For the purposes of the present document, the terms given in 3GPP TR 21.905 [1] and the following apply. A term defined in the present document takes precedence over the definition of the same term, if any, in 3GPP TR 21.905 [1].

3.2 Symbols

Void.

3.3 Abbreviations

For the purposes of the present document, the abbreviations given in 3GPP TR 21.905 [1] and the following apply. An abbreviation defined in the present document takes precedence over the definition of the same abbreviation, if any, in 3GPP TR 21.905 [1].

BSS	Business Support System
MnS	Management Service
PM	Performance Management
SBMA	Service Based Management Architecture
WI	Work Item

4 Issue investigations and potential issue solutions

4.1 Issue #1: Scope of specifications

4.1.1 Description

4.1.1.1 3GPP TS 28.533

3GPP TS 28.533 [2] (the TS is only valid for 5G and exists in Rel-15, 16 and 17):

Scope:

There is no limitation in the scope that the TS is only valid for 5G (or rather not valid for 2G, 3G and legacy 4G).

There are no borders for where the SBMA is valid, which gives some problems when dealing with external entities governed by other fora, e.g. interfaces with MANO, towards verticals, other operators etc. All that control is left to access control, which is not (yet) specified. There is a link with the studies FS_MNSAC and FS_NSCE.

References:

3GPP TS 28.510 [7], 3GPP TS 28.511 [8], 3GPP TS 28.512 [9], 3GPP TS 28.513 [10], 3GPP TS 28.515 [11], 3GPP TS 28.516 [12], 3GPP TS 28.517 [13], 3GPP TS 28.518 [14], 3GPP TS 28.520 [15], 3GPP TS 28.521 [16], 3GPP TS 28.522 [17], 3GPP TS 28.523 [18], 3GPP TS 28.525 [19], 3GPP TS 28.526 [20], 3GPP TS 28.527 [21] and 3GPP TS 28.528 [22] are referred, but those TSs are not valid for 5G, They are used in clause A.4, which is informative.

4.1.1.2 3GPP TS 28.621

3GPP TS 28.621 [43] (the TS is valid for 3G, 4G and 5G and is valid for IRPs only while up to and including Rel-14 but from and including Rel-15 to and including the current release (Rel-18) it is valid for both IRP and SBMA).

The current 3GPP TS 28.621 [43] has a title which is IRP only while the content is valid for IRP architecture as well as SBMA. It is not clear which Stage 1 requirements are applicable for SBMA.

4.1.1.3 3GPP TS 28.622

3GPP TS 28.622 [23] (The TS is valid for 3G, 4G and 5G and is valid for IRPs only while up to and including Rel-14 but from and including Rel-15 to and including the current release (Rel-18) it is valid for both IRP and SBMA).

The current 3GPP TS 28.622 [23] has following issues:

- A. The current 3GPP TS 28.622 [23] has an IRP only title: "3rd Generation Partnership Project Technical Specification Group Services and System Aspects Telecommunication management; Generic Network Resource Model (NRM) Integration Reference Point (IRP) Information Service (IS) (Release 18)". However, the specification is applied also for Service Based Management Architecture (SBMA).
- B. Clause 1 Scope: The scope is covering IRP architecture only. No SBMA description. This issue is covered in clause 4.1 issue #1.
- C. Clause 2 References:
 - a) A few references are not used. This issue is covered in clause 4.3 issue #3.
 - b) Some referred TSs are IRP only which is not applicable for SBMA architecture.
- D. Clause 3.1 Definitions: There are definitions covering IRP architecture. However, which definitions are applicable for IRP or SBMA or both are unclear.
- E. Clause 4.2 Class diagrams: This clause has mixed IRP and SBMA information. Some of the information are only applicable for IRP. Some are only applicable to SBMA. Some are applicable for both SBMA and IRP. The text in this clause is not clear which part is applicable for which architecture.
- F. Clause 4.3 Class definitions:
 - a) This clause has the same issue as "Class diagrams" section. It mixes class definitions for IPR architecture only, SBMA architecture only, or both. It is not clear which part is applicable to which architecture.
 - b) Some classes applicability is not clear enough. The follows are a few examples only, other classes are not list here:
 - i) 'EP_RP' is applicable for both IRP architecture and SBMA architecture. But it has an SBMA only attribute "supportedPerfMetricGroups". The attribute list becomes very confused.
 - ii) Another example is that 'ThresholdMonitor' is defined for SBMA architecture. But the text does not make it clear if it is (or not) also applicable for IRP architecture.
- G. Clause 4.4 Attribute definitions: This clause has the same issue as "Class diagrams" section. It contains mixed information for IRP only, SBMA only, or both. It is not clear which part is applicable to which architecture. One example is in above bullet F.b.
- H. Clause 4.5 Common notifications: The description text is applicable for SBMA only. However, the notifications shall be applicable for both IRP and SBMA architecture.

4.1.1.4 3GPP TS 28.623

3GPP TS 28.623 [44] (The TS is valid for 3G, 4G and 5G and is valid for IRPs only while up to and including Rel-14 but from and including Rel-15 to and including the current release (Rel-18) it is valid for both IRP and SBMA):

The title, the scope, the definition, and the Solution Set (SS) definitions of current 3GPP TS 28.623 [44] are all IRP architecture. However, 3GPP TS 28.623 [44] also contains SBMA IOCs descriptions. It is very hard to understand which part is applicable to which architecture.

Different solution sets are not consistent among themselves.

4.1.1.5 3GPP TS 28.662

3GPP TS 28.662 [52] (The TS is valid for 3G, 4G and 5G and exists in Rel-15, 16 and 17):

3GPP TS 28.662 [52] is made for IRP architecture, but is applied also for Service Based Management Architecture, SBMA.

This NRM would be beneficial to be included in SBMA, but an update is needed.

4.1.2 Potential solutions

4.1.2.1 Solution #1-1 scope of 3GPP TS 28.533

- a) Introduce the limitation that the TS is not valid for 2G, 3G and 4G in the Scope clause.
- b) Introduce text that 3GPP TS 28.533 [2] is valid for SBMA.
- c) Introduce text that access rights for interfaces are outside the scope for 3GPP TS 28.533 [2] (this is to be replaced with a TS number when such a TS is published).

Also to be discussed whether access rights per external (and internal) interfaces are to be documented in some way.

4.1.2.2 Solution #1-2 SBMA for Generic NRM

4.1.2.2.1 3GPP TS 28.621

4.1.2.2.1.1 Solution #1-2.a Update 3GPP TS 28.621

Update the current 3GPP TS 28.621 [43] title to cover SBMA architecture NRM and add any Stage 1 requirements for generic NRM in SBMA.

4.1.2.2.1.2 Solution #1-2.b New TS for SBMA

Keep the current 3GPP TS 28.621 [43] for IRP only. Create a new TS for Stage 1 for generic NRM in SBMA requirements.

4.1.2.2.1.3 Solution #1-2.c New TSs for IRP and SBMA

Create a new TS for generic NRM IRP (with the IRP content from 3GPP TS 28.621 [43]) and create a new TS for Stage 1 for generic NRM in SBMA requirements.

4.1.2.2.1.4 Solution #1-2.d update 3GPP TS 28.621 scope

Update the current 3GPP TS 28.621 [43] in the scope clause that Rel-14 is the version valid for IRP while the current release is valid for SBMA, because up to and including Rel-14 3GPP TS 28.621 [43] is valid only for IRPs while from Rel-15 up to and including the current release (Rel-18) it is valid for both IRP and SBMA (see issue description for issue#1 3GPP TS 28.621 [43]).

4.1.2.2.1.5 Solution #1-2.e Merge stage 1, 2 and 3.

New specifications may be merged into one TS for stage 1, 2 and 3.

4.1.2.2.2 3GPP TS 28.622

4.1.2.2.2.1 Solution #1-2.f update 3GPP TS 28.622

Update the current 3GPP TS 28.622 [23] with enough clarifications to cover both IRP and SBMA architecture NRM.

4.1.2.2.2.2 Solution #1-2.g New TS for SBMA

Create a new TS for generic NRM in SBMA and maintain 3GPP TS 28.622 [23] for IRP information only.

4.1.2.2.2.3 Solution #1-2.h New TSs for IRP and SBMA

Create a new TS for generic NRM information service in SBMA and keep 3GPP TS 28.622 [23] as is (with a note that any SBMA related updates will be continued in the new TS after R18).

4.1.2.2.2.4 Solution #1-2.i update 3GPP TS 28.622 scope

Update the current 3GPP TS 28.622 [23] in the scope clause that Rel-14 is the version valid for IRP while the current release is valid for SBMA, because up to and including Rel-14 3GPP TS 28.622 [23] is valid only for IRPs while from Rel-15 up to and including the current release (Rel-18) it is valid for both IRP and SBMA (see issue description for issue#1 3GPP TS 28.622 [23]).

4.1.2.2.2.5 Solution #1-2.j Merge stage 1, 2 and 3.

New specifications may be merged into one TS for stage 1, 2 and 3.

4.1.2.2.3 3GPP TS 28.623

4.1.2.2.3.1 Solution #1-2.k update 3GPP TS 28.623

Update the current 3GPP TS 28.623 [44] title, scope, definition, and the Solution Set (SS) definitions to cover both IRP and SBMA architecture NRM.

4.1.2.2.3.2 Solution #1-2.l New TS for SBMA

Create a new TS for Stage 3 Solution Set (SS) definitions for SBMA architecture NRM. This new stage 3 TS can be combined with the proposed new stage 2 TS.

Keep 3GPP TS 28.623 [44] for IRP only.

4.1.2.2.3.3 Solution #1-2.m New TSs for IRP and SBMA

Create a new TS for generic NRM information service in SBMA and keep 3GPP TS 28.623 [44] as is (with a note that any SBMA related updates will be continued in the new TS after R18).

4.1.2.2.3.4 Solution #1-2.n update 3GPP TS 28.623 scope

Update the current 3GPP TS 28.623 [44] in the scope clause that Rel-14 is the version valid for IRP while the current release is valid for SBMA, because up to and including Rel-14 3GPP TS 28.622 [23] is valid only for IRPs while from Rel-15 up to and including the current release (Rel-18) it is valid for both IRP and SBMA (see issue description for issue#1 3GPP TS 28.622 [23]).

4.1.2.2.3.5 Solution #1-2.o Merge stage 1, 2 and 3.

New specifications may be merged into one TS for stage 1, 2 and 3.

4.1.2.3 Solution #1-3 scope of referred TSs in 3GPP TS 28.533

The TSs 3GPP TS 28.510 [7], 3GPP TS 28.511 [8], 3GPP TS 28.512 [9], 3GPP TS 28.513 [10], 3GPP TS 28.515 [11], 3GPP TS 28.516 [12], 3GPP TS 28.517 [13], 3GPP TS 28.518 [14], 3GPP TS 28.520 [15], 3GPP TS 28.521 [16], 3GPP TS 28.522 [17], 3GPP TS 28.523 [18], 3GPP TS 28.525 [19], 3GPP TS 28.526 [20], 3GPP TS 28.527 [21] and 3GPP TS 28.528 [22] are present in an informative annex so they can be removed.

4.1.2.4 Solution #1-4 new SBMA TS for Generic RAN NRM

Replace 3GPP TS 28.662 [52] with a new 5G TS for SBMA with information only applicable to SBMA. New information might be introduced. IRP applicable information is kept in 3GPP TS 28.662 [52], which would be valid for older systems using IRP the architecture.

4.2 Issue #2: Content errors

4.2.1 Description

3GPP TS 28.533 [2]:

Content error:

3GPP TS 32.103 [24] claims that 3GPP TS 28.533 [2] is a "generic" TS (in contrast to "5G specific"), yet clause 4.6 is using 5G entities, clauses 5.2 and 5.4 are specifying 3GPP management system interactions with NFV MANO and NWDAF.

Clause 4.2.2: MnS component type A is said to be generic with regards to operations and notifications. But is really PM notifications etc. generic?

Clause 6 contains use cases and requirements, which should not be included in a stage 2 TS.

3GPP TS 28.533 [2] claims to be the architecture TS for SBMA, but it does not have any boundaries for where it is valid (e.g. is service management and BSS included?).

Implementation errors:

Clause 6: The requirement tag **REQ-MnSD-FUN-X** has not been given a number.

4.2.2 Potential solutions

4.2.2.1 Solution #2-1 3GPP specific information in TSs classified as generic

3GPP TS 28.533 [2] clause 4.2.2: Discuss whether operations and notifications used in 5G that are specific for a certain functionality is included in MnS component type A which is stated to be generic. The TS is to be changed accordingly to the agreement:

Atl.1 3GPP TS 28.533 [2] should be generic, so the content which are not generic should be deleted.

Alt.2 3GPP TS 28.533 [2] should be 5G specific, so all information about generic and 5G specific TSs should be removed.

4.2.2.2 Solution #2-2 for stage 1 content in stage 2 3GPP TS 28.533

Move clause 6 in 3GPP TS 28.533 [2] to 3GPP TS 28.537 [25].

Change **REQ-MnSD-FUN-X** to **REQ-MnSD-FUN-1** (but not in 3GPP TS 28.533 [2]).

4.3 Issue #3: Reference errors

4.3.1 Description

3GPP TS 28.533 [2]:

3GPP TS 32.101 [3] is referenced, but that TS is not valid for 5G. But the reference is only present in clause 2.

3GPP TS 32.425 [26] is referenced, but that TS is not valid for 5G (also 3GPP TS 28.552 [27] refers to 3GPP TS 32.425 [26]).

3GPP TS 28.500 [28] is referenced, but that TS is not valid for 5G.

3GPP TS 28.622 [23] is referenced, but that is an IRP TS (but used for 5G).

3GPP TS 28.622 [23]:

3GPP TS 32.111-2 [29] is referenced, but the reference is only present in clause 2.

3GPP TS 32.662 [30] is referenced, but the reference is only present in clause 2.

4.3.2 Potential solutions

4.3.2.1 Solution #3-1 Make not used references void

- a) Make reference to 3GPP TS 32.101 [3] void in 3GPP TS 28.533 [2].
- b) Make the references to 3GPP TS 32.111-2 [29] and 3GPP TS 32.662 [30] void in 3GPP TS 28.622 [23].

4.4 Issue #4: SBMA supporting management of 5G SA and NSA scenarios

4.4.1 Description

4.4.1.1 Analysis of the existing specification capabilities

Service based management architecture (SBMA) and corresponding MnS are introduced in 5G management architecture in 3GPP TS 28.533 [2], and a different management reference model (i.e. IRP) had been used to manage the network before 5G era in 3GPP TS 32.101 [3].

The analysis is based on the following understanding of the existing specification capabilities:

- The management mechanism of LTE supports interface IRP and NRM IRP models.
- The management mechanism of 5G supports MnS which includes MnS component type A (Operation/Notification), MnS component type B (NRM models) and MnS component type C (Alarm/Performance information).
- LTE NRM (with enhancement of YAML or YANG solution set) can be used as MnS component type B and work together with MnS component type A.

4.4.1.2 Management support for NG-RAN Overall Architecture

As description in 3GPP TS 38.300 [4], an NG-RAN node is either a gNB or an ng-eNB which are interconnected with each other by means of the Xn interface and connected with 5GC by means of the NG interface, more specifically to the AMF by means of the NG-C interface and to the UPF by means of the NG-U interface. The NG-RAN architecture is introduced in 3GPP TS 38.300 [4], as follows.

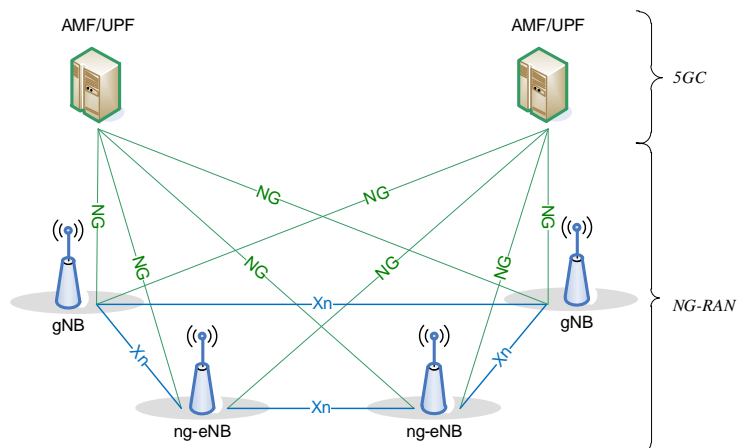

Figure 4.4.1.2-1: NG-RAN Overall Architecture

NOTE: The ng-eNB node provides E-UTRA user plane and control plane protocol terminations towards the UE, and connects via the NG interface to the 5GC.

In order to provide management support for NG-RAN, the 3GPP management system needs to support the management for gNB, ng-eNB and 5GC. There are potential 2 management options to support, as follows.

NG-RAN management Option#1

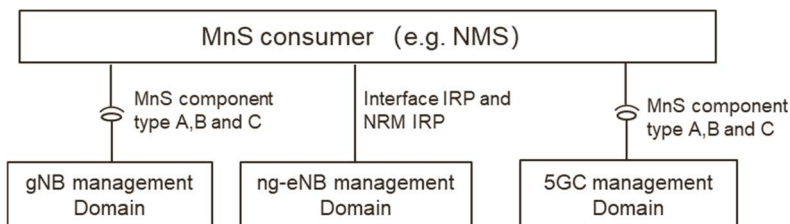

Figure 4.4.1.2-2: NG-RAN management Option#1

In the NG-RAN management Option#1:

- The gNB management domain provides MnS (including MnS component type A, B and C) for the management of gNB.
- The ng-eNB management domain provides IRP (including interface IRP and NRM IRP) for the management of ng-eNB.
- The 5GC management domain provides MnS (including MnS component type A, B and C) for the management of 5GC.

NG-RAN management Option#2

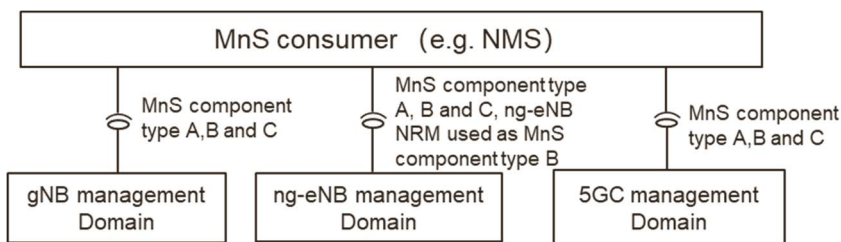

Figure 4.4.1.2-3: NG-RAN management Option#2

In the NG-RAN management Option#2:

- The gNB management domain provides MnS (including MnS component type A, B and C) for the management of gNB
- The ng-eNB management domain provides MnS ((including MnS component type A, B and C) for the management of ng-eNB. In this case, ng-eNB NRM used as MnS component type B, which means the YAML/YANG solution set for ng-eNB needs to be provided.
- The 5GC management domain provides MnS (including MnS component type A, B and C) for the management of 5GC.

4.4.1.3 Management support for EN-DC Overall Architecture

NG-RAN supports Multi-Radio Dual Connectivity (MR-DC) operation whereby a UE in RRC_CONNECTED is connected to two different nodes, one providing NR access and the other one providing either E-UTRA or NR access. One node acts as the MN and the other as the SN. The MN and SN are connected via a network interface and at least the MN is connected to the core network (e.g. EPC).

The following figure illustrates the MR-DC with EPC (i.e. EN-DC) architecture in 3GPP TS 37.340 [5].

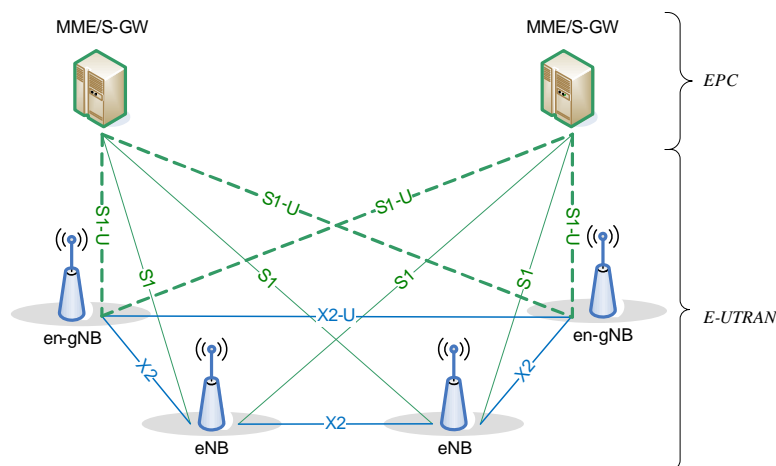

Figure 4.4.1.3-1: EN-DC Overall Architecture

NOTE: The en-gNB node provides NR user plane and control plane protocol terminations towards the UE, and acts as Secondary Node in EN-DC.

In order to provide management support for EN-DC, 3GPP management system needs to provide the management for en-gNB, eNB and EPC. There are also potential 2 management options to support, as follows.

EN-DC management Option#1

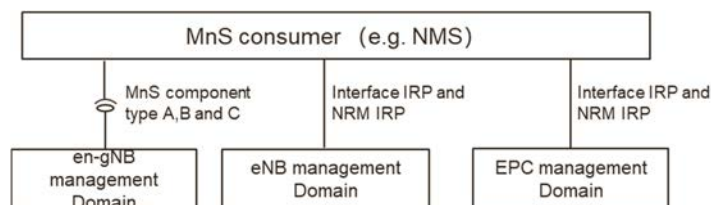

Figure 4.4.1.3-2: EN-DC management option#1

In EN-DC management option#1:

- The en-gNB management domain provides MnS (including component type A, B and C) for management of en-gNB.

- The eNB management domain provides IRP (including interface IRP and NRM IRP) for the management of eNB.
- The EPC management domain provides IRP (including interface IRP and NRM IRP) for the management of EPC.

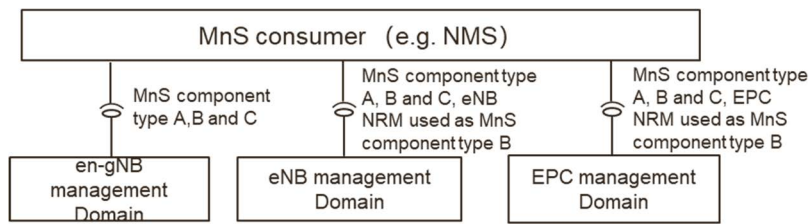

Figure 4.4.1.3-3: EN-DC management Option#2

EN-DC management Option#2

In EN-DC management option#2:

- The en-gNB management domain provides MnS (including component type A, B and C) for management of en-gNB.
- The eNB management domain provides MnS (including component type A, B and C) for management of eNB. In this case, eNB NRM used as MnS component type B, which means the YAML/YANG solution set for eNB NRM needs to be provided.
- The EPC management domain provides MnS (including component type A, B and C) for management of EPC. In this case, EPC NRM used as MnS component type B, which means the YAML/YANG solution set for EPC NRM needs to be provided.

4.4.2 Potential solutions #4-1

The above potential 4 management mechanism options described in clause 4.4.1 could be classified as two management options, as follows.

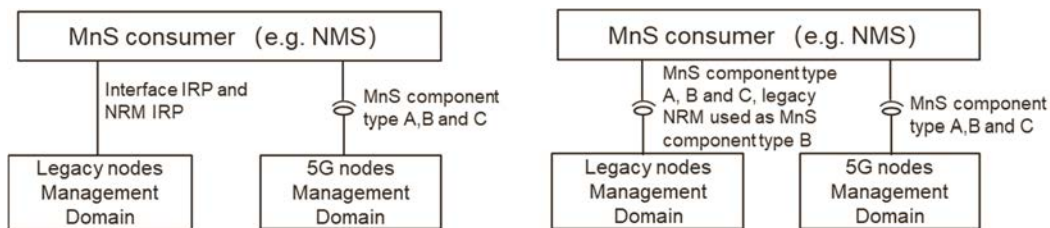

Figure 4.4.2-1: Management Option A and B for 5G SA and NSA

Option#A (including above NG-RAN management Option#1 and EN-DC management Option#1)

- The legacy nodes (e.g. eNB, ng-eNB and EPC) management domain provides IRP (including interface IRP and NRM IRP) for the management of legacy nodes.
- The 5G nodes (e.g. gNB, en-gNB and 5GC) provides MnS (including MnS component type A, B and C) for the management of 5G nodes.

Option#B (including above NG-RAN management Option#2 and EN-DC management Option#2)

- The legacy nodes (e.g. eNB, ng-eNB and EPC) management domain provides MnS (including MnS component type A, B and C) for the management of legacy node. In this case, legacy node NRM used as MnS component type B, which means the YAML/YANG solution set for legacy node NRM needs to be provided.
- The 5G nodes (e.g. gNB, en-gNB and 5GC) provides MnS (including MnS component type A, B and C) for the management of 5G nodes.

4.5 Issue #5: SBMA supporting management architecture and frameworks in other SDOs

4.5.1 Description

There are some relevant works on the architectures and frameworks for automation of management and orchestration in other Standards Developing Organizations (SDOs) in industry. This clause provides a brief overview on the works in the related SDOs.

4.5.2 Potential solutions

4.5.2.1 ETSI ISG ZSM

4.5.2.1.1 Introduction

The goal of ETSI ZSM is to enable zero-touch automated network and service management in a multivendor environment.

As documented in ETSI GS ZSM 002 [6], it provides the ZSM framework reference architecture as shown in figure 4.5.2.1.1-1 and distributed management and data services, organized into management domains and integrated via an integration fabric. The integration fabric is used to enable management service consumption, communication, and integration with 3rd party management systems. The cross-domain data service allows data sharing across domains. All management services provide a set of capabilities for their consumption.

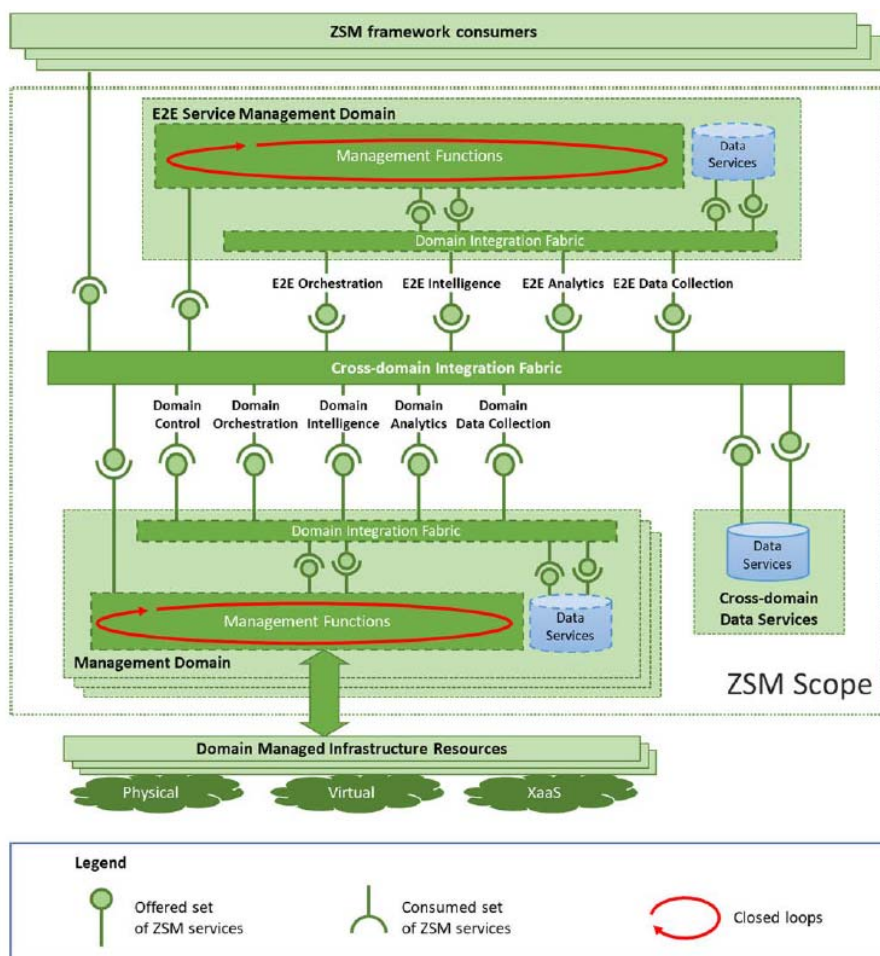

Figure 4.5.2.1.1-1: ZSM framework reference architecture

In figure 4.5.2.1.1-1, every management domain, as well as the E2E service management domain, provides a set of ZSM service capabilities by management functions that expose and/or consume a set of service end-points. The cross-domain integration fabric facilitates providing capabilities and accessing end-points cross-domain. Some services are only provided and consumed locally inside the management domain.

4.5.2.1.2 Potential solutions #5-1

3GPP management service deployment framework based on ZSM framework reference architecture is captured in clause 5.3 of 3GPP TS 28.533 [2]. 3GPP SBMA is aligned with ZSM framework reference architecture.

4.6 Issue #6: Software management feature in SBMA for 5G

4.6.1 Description

3GPP TS 32.531 [31], 3GPP TS 32.532 [32], 3GPP TS 32.533 [33] define the requirements, Information Solution and CORBA solution set for software management which includes Automated software management and non-automated software management. 3GPP TS 28.525 [19] and 3GPP TS 28.526 [20] describes the management aspects for VNF application software (i.e. 3GPP network function software), which includes reusing the software Management IRP [32] for the interaction between NM and EM. The management of software for VNF itself is not defined in 3GPP, which is in the scope of ETSI NFV. Software Management IRP [32] is applicable for the deployments using IRP Framework, which is not applicable for the deployments using SBMA.

The 5G management is using the SBMA, so corresponding software management solution is missing.

4.6.2 Potential solutions

Introduce a software management feature in SBMA which can be applicable for 5G and future network is needed. The management of software for VNF itself is not included, which is defined by ETSI NFV.

4.7 Issue #7: Inventory missing in 5G

4.7.1 Description

LTE has specifications about inventory: 3GPP TS 28.631 [34], 3GPP TS 28.632 [35] and 3GPP TS 28.633 [36] that define the requirements, Network Resource Model Information Service (IS) and Solution Set. 5G does not have anything similar, even though 5G also consist of software, hardware, network functions and licences.

The attribute table is not follow the latest template documented in 3GPP TS 32.156 [37], for example, the legal value for "isReadable", "isWritable", "invariant" and "isNotifiable" should be True or False.

4.7.2 Potential solutions

Replace 3GPP TS 28.631 [34], 3GPP TS 28.632 [35] and 3GPP TS 28.633 [36] with a new 5G TSs for SBMA:

- Provide the YANG and YAML solution sets for inventory management NRM in SBMA.

4.8 Issue #8: Use of Models in SBMA

4.8.1 Description

The following existing concepts are related to SBMA:

- 3GPP TS 28.533 [2] Management Function: A Management Function (MnF) is a logical entity playing the roles of MnS consumer and/or MnS producer. Management Function can be deployed as a separate entity or embedded in Network Function to provide MnS(s).

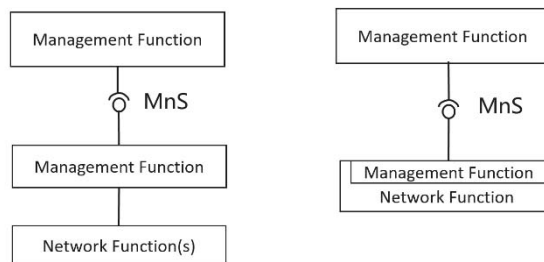

Figure 4.8.1-1: Examples of MnS deployment scenario

- 3GPP TR 21.905 Network Element: A discrete telecommunications entity which can be managed over a specific interface e.g. the RNC.
- 3GPP TS 28.533 [2]/3GPP TS 23.501 [53] Network Function: A 3GPP adopted or 3GPP defined processing function in a network, which has defined functional behaviour and 3GPP defined interfaces.

The following IOCs are specified to represent Network Element and Network Function:

- 3GPP TS 28.622 [23] ManagedElement IOC: This IOC represents telecommunications equipment or TMN entities within the telecommunications network providing support and/or service to the subscriber. A ManagedElement IOC is used to represent a Network Element defined in 3GPP TS 32.101 [3] including virtualization or non-virtualization scenario.
- 3GPP TS 28.622 [23] ManagedFunction IOC: This IOC is provided for sub-classing only. It provides attribute(s) that are common to functional IOCs. Note that a ManagedElement may contain several managed functions, a managed function may contain other managed functions as specified for the specific subclass. This IOC can represent a telecommunication function either realized by software running on dedicated hardware or realized by software running on NFVI.

The following IOCs as specified in 3GPP TS 28.622 [23] are used to represent Management Function provided by MnS Producer:

- 3GPP TS 28.622 [23] MnsAgent IOC: The MnsAgent represents the MnS producers, incl. the supporting hardware and software, available for a certain management scope that is related to the object name-containing the MnS Agent.
- 3GPP TS 28.622 [23] ManagementNode IOC: This IOC represents a telecommunications management system (EM) within the TMN that contains functionality for managing a number of ManagedElements (MEs).

NOTE: This description is to be updated to replace use of EM.

4.8.2 Potential solutions

This clause provides the description of using NRM to represent management of management function, network function, and network element.

Management Function could be deployed in following different deployment scenarios:

- The Management Function can be deployed in management system, including:
 - The Management Function deployed in domain management system.
 - The Management Function deployed in cross domain management system.
- The Management Function deployed in Network Element.

From the three deployment scenarios of Management Functions above. Management Functions deployed in domain management system and Management Function deployed in Network Element need to be managed as managing network node in 3GPP management system. The way of managing the Management Function are modelled in corresponding management function IOC.

ManagementNode IOC represents a telecommunications management system within the TMN provided by vendor that contains management functionalities for managing a number of ManagedElements (MEs).

The Management Functions are managed by corresponding management function IOC as defined in 3GPP TS 28.541 [46], 3GPP TS 28.104 [47], 3GPP TS 28.105 [48], 3GPP TS 28.536 [49] and 3GPP TS 28.312 [50]:

- IOC for Management of D-SON function:
 - D-SON of ANR in 3GPP TS 28.541 [46] DANRManagementFunction IOC.
 - D-SON Energy Saving (ES) functions in 3GPP TS 28.541 [46] DESManagementFunction IOC.
 - D-SON RACH functions in 3GPP TS 28.541 [46] DRACHOptimizationFunction.
 - D-SON MRO functions in 3GPP TS 28.541 [46] DMROFunction.
 - D-SON PCI Configuration functions in 3GPP TS 28.541 [46] DPCIConfigurationFunction.
 - D-SON LBO functions in 3GPP TS 28.541 [46] DLBOFunction.
- IOC for Management of management functions:
 - EM centralized SON Energy Saving (ES) functions in 3GPP TS 28.541 [46] CESManagementFunction IOC.
 - EM centralized-SON PCI Configuration functions in 3GPP TS 28.541 [46] CPCIConfigurationFunction.
 - EM centralized-SON Energy Saving (ES) functions in 3GPP TS 28.541 [46] CESManagementFunction.
 - EM centralized-SON CCO functions in 3GPP TS 28.541 [46] CCOFunction.
 - MDFunction in 3GPP TS 28.104 [47].
 - AIMLTrainingFunction in 3GPP TS 28.105 [48].
 - AssuranceClosedControlLoop in 3GPP TS 28.536 [49].

Editor's note: other management functions to be added with working progress. The criteria for identifying what kind of ManagementFunction should be managed is FFS.

Table 4.8.2-1 captures the relation between the concepts and related models:

Table 4.8.2-1: Relation between the concepts and related models

Concepts	Illustration of Related Management Models
3GPP TS 28.622 [23] ManagementNode	A telecommunications management system within the TMN provided by vendor that contains management functionalities for managing a number of ManagedElements (MEs) are represented by ManagementNode IOC defined in 3GPP TS 28.622 [23], and a number of management functions.
3GPP TS 28.533 [2] Management Function	The corresponding XXXManagementFunction IOC is used to support the managing of XXXMnF.
3GPP TR 21.905 Network Element	A network element is represented by ManagedElement IOC defined in 3GPP TS 28.622 [23].
3GPP TS 28.533 [2]/3GPP TS 23.501 [53] Network Function	A Network function is represented by ManagedFunction IOC defined in 3GPP TS 28.622 [23].

It is recommended the following IOCs which could be used to represent MnFs to be managed. The modelling is not changed for existing functions to keep the backward compatibility.

Table 4.8.2-2: IOCs which could be used to represent MnFs to be managed

TS	IOC	Inherent from	Contained by
3GPP TS 28.541 [46]	1. CPCIConfigurationFunction 2. CESManagementFunction 3. CCOFunction	Top	1. ManagedEntity(SubNetwork/ManagedElement/NRCe IIDU/ManagementNode) 2. ManagedEntity(SubNetwork/ManagedElement/NRCe IICU/ManagementNode) 3. SubNetwork/ManagementNode
3GPP TS 28.104 [47]	MDAFunction	ManagedFunction	MDAEntity (SubNetwork/ManagedElement/ManagedFunction/ManagementNode)
3GPP TS 28.105 [48]	AIMLTrainingFunction	ManagedFunction	ManagedEntity(Subnetwork/ManagedElement/ManagementFunction/ManagementNode)
3GPP TS 28.536 [49]	AssuranceClosedControlLoop	Top	SubNetwork/ManagedElement/ManagementNode

Editors' Note: whether the MnFs to be managed IOCs are needed to be inherited from a same root IOC is FFS.

The ManagementFunction IOCs listed in table 4.8.2-2 can be used to support different deployment scenarios based on which managed entity contain such Management Function IOCs. For example, following figure 4.8.2-1 is one example for management function model, in which all ManagementFunction IOCs (i.e. MDAFunction, AIMLtrainingFunction, AssuranceClosedControlLoop, CESManagementFunction, CCOFunction and CPCIConfigurationFunction) are contained by SubNetwork.

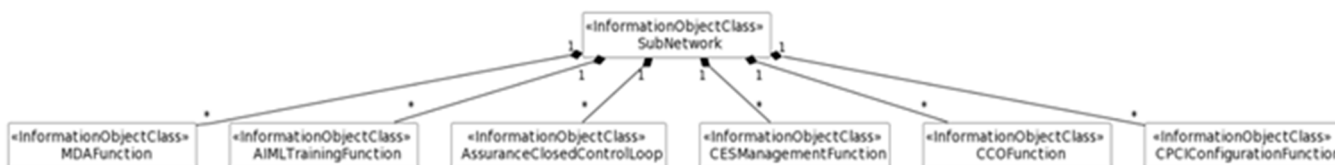

Figure 4.8.2-1: An example of management function model

Above example for management function model can be used to support following deployment scenario for management function, see figure 4.8.2-2. In this deployment scenario example, RAN network management provides the following management capabilities (including MDA capabilities, AIML Training capabilities, AssuranceClosedControlLoop capabilities, CESManagement capabilities, CCO capabilities and CPCIConfigurationcapabilities).

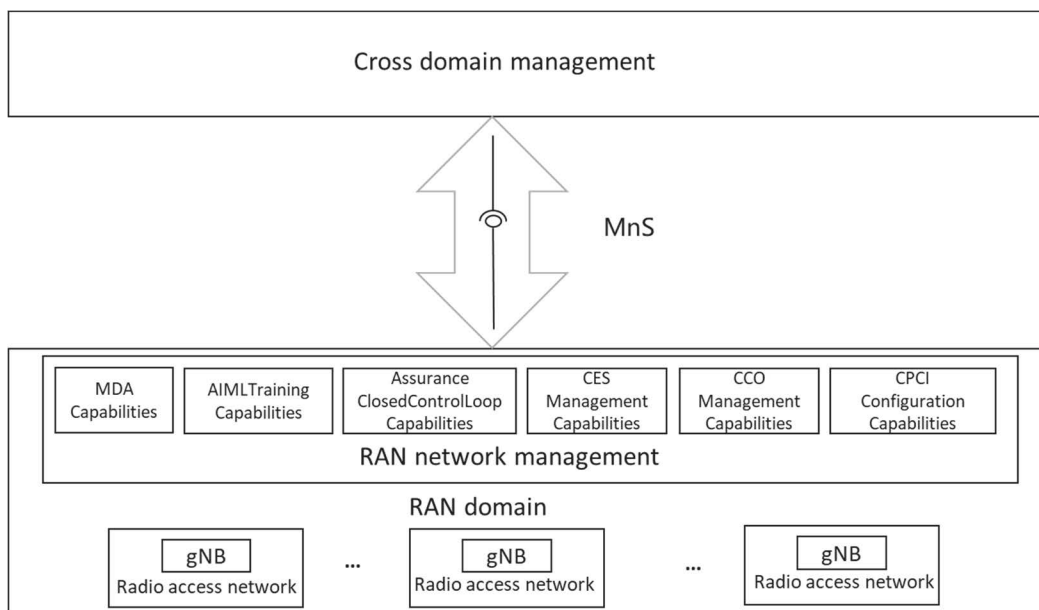

Figure 4.8.2-2: An example of deployment scenario for management function contained by SubNetwork

The ManagementFunctions in management function model in Figure 4.8.2-1 provides the capabilities to allow cross domain management to control these management capabilities via corresponding MnSs. See below:

- MDAFunction is used to represent MDA capabilities in RAN network management.
- AIMLtrainingFunction is used to represent AIMLTraining capabilities in RAN network management.
- AssuranceClosedControlLoop is used to represent AssuranceClosedControlLoop capabilities in RAN network management.
- CESManagementFuncuion is used to represent CESManagement capabilities in RAN network management.
- CCOFuncuion is used to represent CCO capabilities in RAN network management.
- CPCIconfigurationFunction is used to represent CPCIconfiguration capabilities in RAN network management.

4.9 Issue #9: Improvement on the management function description

4.9.1 Description

The following information is documented in 3GPP TS 32.101 [3] to describe the TMN architecture aspects and the management functions.

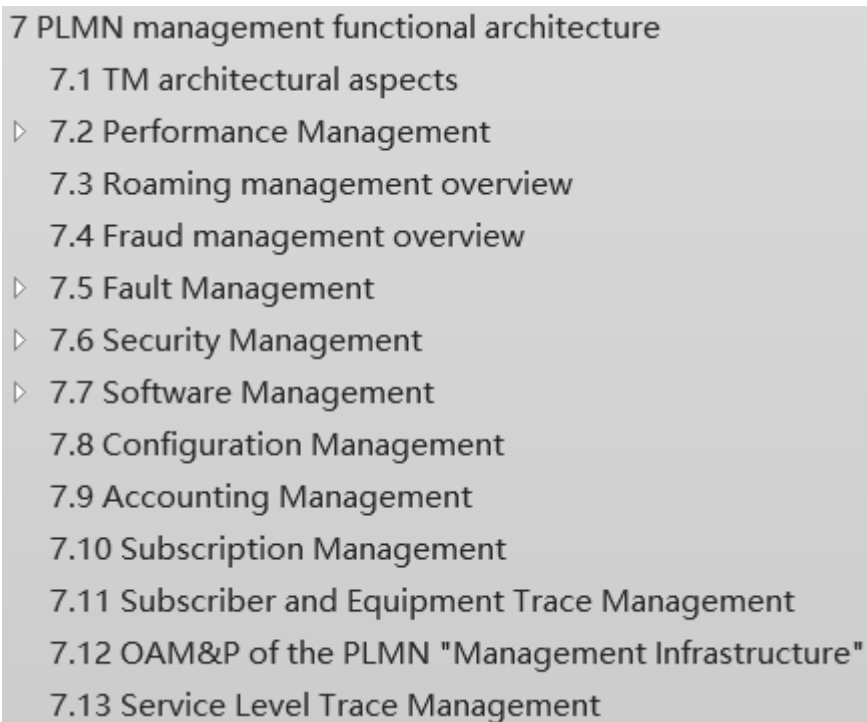

7 PLMN management functional architecture

- 7.1 TM architectural aspects
- ▷ 7.2 Performance Management
- 7.3 Roaming management overview
- 7.4 Fraud management overview
- ▷ 7.5 Fault Management
- ▷ 7.6 Security Management
- ▷ 7.7 Software Management
- 7.8 Configuration Management
- 7.9 Accounting Management
- 7.10 Subscription Management
- 7.11 Subscriber and Equipment Trace Management
- 7.12 OAM&P of the PLMN "Management Infrastructure"
- 7.13 Service Level Trace Management

Analysis:

- 3GPP TS 32.101 [3] defines the management principles and high-level requirements for the management of PLMNs. Some descriptions in corresponding area in clause 7 of 3GPP TS 32.101 [3] can be improved and used for SBMA.

The following management features are captured in annex of 3GPP TS 28.533 [2], as follows.

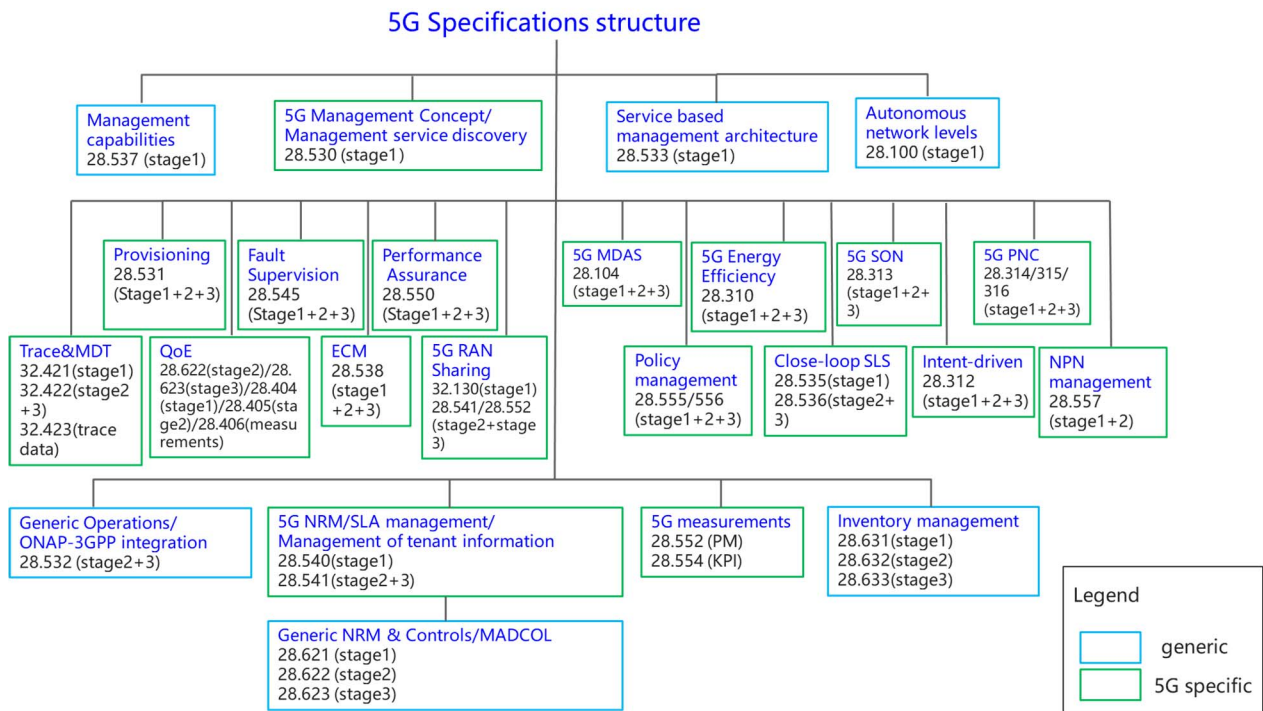

Figure 4.9.1-1: Overview of 5G management specifications

The related management features description in 3GPP TS 28.533 [2] are limited compared with the management functions description in 3GPP TS 32.101 [3].

4.9.2 Potential solutions

4.9.2.1 Management function description

Elaborate the management functional overviews in 3GPP TS 28.533 [2] with taking into account of the management function description information in 3GPP TS 32.101 [3] clause 7.

4.9.2.2 Usage of CRUD operations and NRM fragment in SBMA

Following is the overview of usage of CRUD operations and NRM fragments in SBMA.

If CRUD operations are supported, it is not needed to support the equivalent non-CRUD operations. (e.g. if CRUD operations for NtfSubscriptionControl IOC are supported, it is not needed to support subscribe/unsubscribe operations).

NOTE: The usage of non-CRUD operations in the SBMA are not listed in table 4.9.2.2-1 (e.g. Streaming management operations, defined in 3GPP TS 28.532 [45] clause 11.5.1, by Streaming Data Reporting MnS are not-CRUD operations).

Table 4.9.2.2-1: Overview of the usage of CRUD operations and NRM fragments in SBMA

Supported MnS Components		Usage
MnS Component type A	MnS Component type B	
CRUD operations	Generic NRM (3GPP TS 28.622 [23]) (e.g. SubNetwork, ManagedElement IOC)	Common Management
CRUD operations	NRM fragment for NR (3GPP TS 28.541 [46])	NR Provisioning
CRUD operations	NRM fragment for NRM 5GC (3GPP TS 28.541 [46])	5GC Provisioning
CRUD operations	NRM fragment for Network Slice (3GPP TS 28.541 [46])	Network Slice Provisioning
CRUD operations	PM control NRM fragment (3GPP TS 28.622 [23])	Performance
CRUD operations	Threshold monitoring control NRM fragment (3GPP TS 28.622 [23])	Performance Threshold Monitoring
CRUD operations	Trace control NRM fragment (3GPP TS 28.622 [23])	Trace
CRUD operations	QoE Measurement Collection control NRM fragment (3GPP TS 28.622 [23])	QoE
CRUD operations	FM control NRM fragment (3GPP TS 28.622 [23])	Fault Supervision
CRUD operations	File retrieval NRM fragment (3GPP TS 28.622 [23])	File Retrieval
CRUD operations	File download NRM fragment (3GPP TS 28.622 [23])	File Download
CRUD operations	Notification subscription control NRM fragment (3GPP TS 28.622 [23])	Subscription
CRUD operations	Heartbeat notification control NRM fragment (3GPP TS 28.622 [23])	Heartbeat
CRUD operations	NRM fragment for ML training (3GPP TS 28.105 [48])	AI/ML Management
CRUD operations	NRM fragment for MDA request and MDA report (3GPP TS 28.104 [47])	MDA
CRUD operations	NRM fragment for DANR Management (3GPP TS 28.541 [46]) NRM fragment for DES Management (3GPP TS 28.541 [46]) NRM fragment for DRACH Management (3GPP TS 28.541 [46]) NRM fragment for DMRO Management (3GPP TS 28.541 [46]) NRM fragment for DPCI Management (3GPP TS 28.541 [46]) NRM fragment for CES Management (3GPP TS 28.541 [46]) NRM fragment for CPCI Management (3GPP TS 28.541 [46]) NRM fragment for DLBO Management (3GPP TS 28.541 [46]) NRM fragment for CCO Management (3GPP TS 28.541 [46])	SON Policy
CRUD operations	NRM fragment for intent (3GPP TS 28.312 [50])	Intent Driven Management
CRUD operations	Edge NRM Fragment (3GPP TS 28.538 [51])	Edge Computing Provisioning
CRUD operations	ManagementDataCollection control NRM fragment (3GPP TS 28.622 [23])	ManagementDataCollection
CRUD operations	MnS Registry NRM fragment (3GPP TS 28.622 [23])	MnS Registry and Discovery
CRUD operations	Assurance management NRM fragment (3GPP TS 28.536 [49])	Communication Service Assurance
NOTE: The term "Usage" needs to be revisited in the normative phase.		

4.9.2.3 Notifications supported by management sets in SBMA

TBD

4.10 Issue #10: Use of 32.401 in SBMA

4.10.1 Description

Concepts and definitions in 3GPP TS 32.401 [38] are used in 3GPP TS 28.552 [27], Therefore 3GPP TS 32.401 [38] is referred to in 3GPP TS 28.552 [27].

3GPP TS 32.401 [38] is written for an IRP architecture, for which it is still needed. To include SBMA in 3GPP TS 32.401 [38] will be almost duplicating the specification.

4.10.2 Potential solutions

It is proposed to make:

- 1) a new TS for Performance Management (PM); Concept and requirements; or
- 2) to include changes into 3GPP TS 28.550 [55];

in a new work item in Rel-18.

4.11 Issue #11: Use of 32.404 in SBMA

4.11.1 Description

Major issues found:

- 1) Concepts, definitions and the template in 3GPP TS 32.404 [39] are used in 3GPP TS 28.552 [27], therefore 3GPP TS 32.404 [39] is referred to in 3GPP TS 28.552 [27].
- 2) Some terms (e.g. IRP and NE) used are not valid in SBMA.
- 3) Some normative references are only to IRP TSs, e.g. references to 3GPP TS 25.331 [40] and 3GPP TS 25.433 [41].
- 4) The PM LCM in clause B.5 is different than the CM LCM. It should be investigated whether they should be aligned/changed.

4.11.2 Potential solutions

It is proposed to update 3GPP TS 32.404 [39] in a new work item in Rel-18.

4.12 Issue#12: illustration of using MnS in management reference model in TS 32.101

4.12.1 Description

In 3GPP TS 32.101 [3], Clause 5.1 illustrates the management reference model which shows the Operations Systems interfacing with other systems. An Operations System supports management interfaces to other systems.

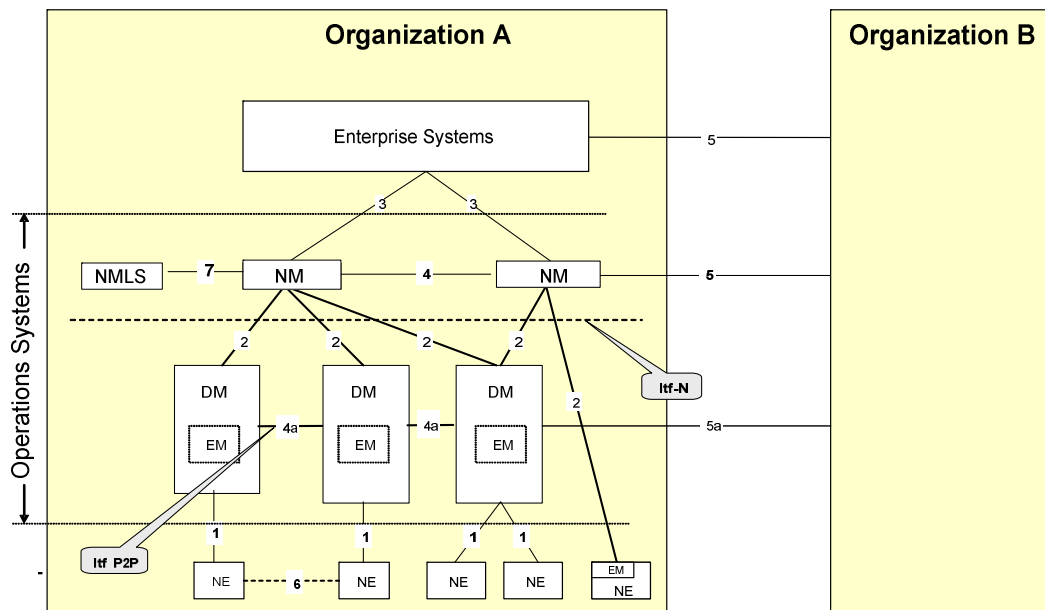

Figure 4.12.1-1: Management reference model

A number of management interfaces in a PLMN are identified in figure 4.12.1-1, namely:

- 1) between the Network Elements (NEs) and the Element Manager (EM) of a single PLMN Organization;
- 2) between the Element Manager (EM) and the Network Manager (NM) of a single PLMN Organization;

NOTE: In certain cases, the Element Manager functionality may reside in the NE in which case this interface is directly from NE to Network Manager). These management interfaces are given the reference name Irf-N and are the primary target for standardization.

- 3) between the Network Managers and the Enterprise Systems of a single PLMN Organization;
- 4) between the Network Managers (NMs) of a single PLMN Organization;
- 4a) between the Domain Managers (DMs) of a single PLMN Organization;
- 5) between Enterprise Systems & Network Managers of different PLMN Organizations;
- 5a) between the Domain Managers (DMs) of different PLMN Organizations;
- 6) between Network Elements (NEs);
- 7) between the Network Management Layer Service (NMLS) and the Network Manager (NM).

IRPs may be implemented at interfaces 2, 3, 4, 5 and 7.

3GPP TS 28.533 [2] introduces the Service Based Management Architecture (SBMA). The fundamental building block of the Service Based Management Architecture (SBMA) is the Management Service (MnS). A MnS is a set of offered capabilities for management and orchestration of network and services. An MnS producer offers its services via a standardized service interface composed of individually specified MnS components (MnS component type A, B, C).

Analysis:

- 1) In 3GPP TS 32.101 [3], there is clearly showing the entities and the corresponding interfaces in the management reference model.
- 2) In 3GPP TS 28.533 [2], the interaction of paradigm of MnS producer and MnS Consumer is defined without indicating the entities.
- 3) The entities in 3GPP TS 32.101 [3] can be illustrated using the MnS consumer and MnS producer according to the way of using interface IRPs.

4.12.2 Potential solutions

There are the following aspects to be considered in the solution of using MnS:

- 1) The management services may be used to support the interoperability in different management scenarios:
 - a) Interoperability within Operation system of a single PLMN Organization.
 - b) Interoperability between BSS and Operation systems within a single PLMN Organization.
 - c) Interoperability between BSS of different PLMN Organizations.
 - d) Interoperability between Operation Systems of different PLMN Organizations.
- 2) Different set of management services may be used for the interoperability between different entities.
- 3) Figure 4.12.2-1 illustrates an example of using management services for supporting interoperability in a multiple players scenario:

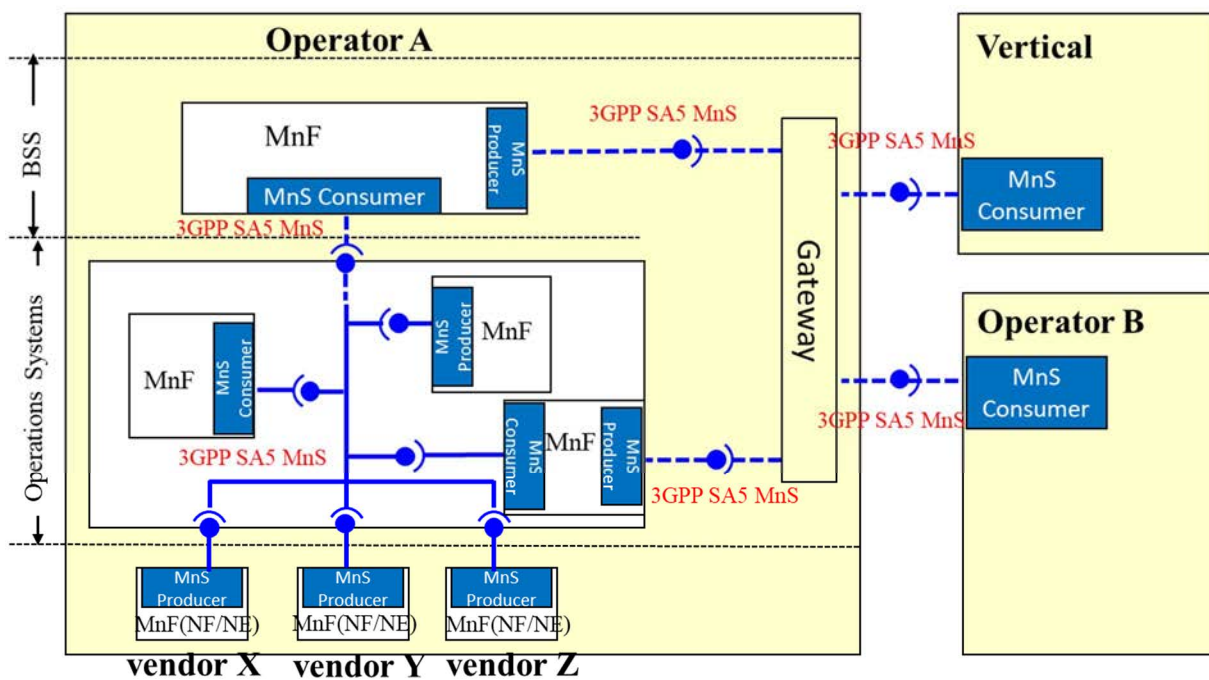

Figure 4.12.2-1: Example of possible usage of MnS

4.13 Issue #13: Analysis on IRP specification needs to support SBMA

4.13.1 Description

The overview of interface IRP and NRM IRP are illustrated in clause 5 and clause 6 in 3GPP TS 32.103 [24] as follows:

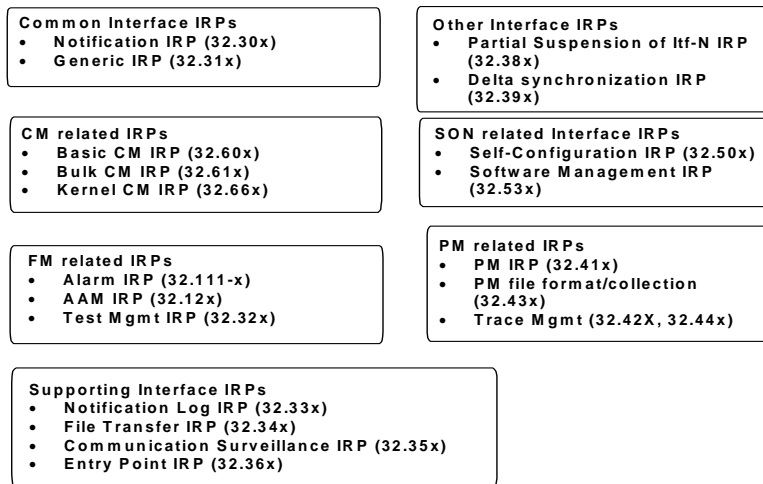

Figure 4.13.1-1: 3GPP Interface IRPs

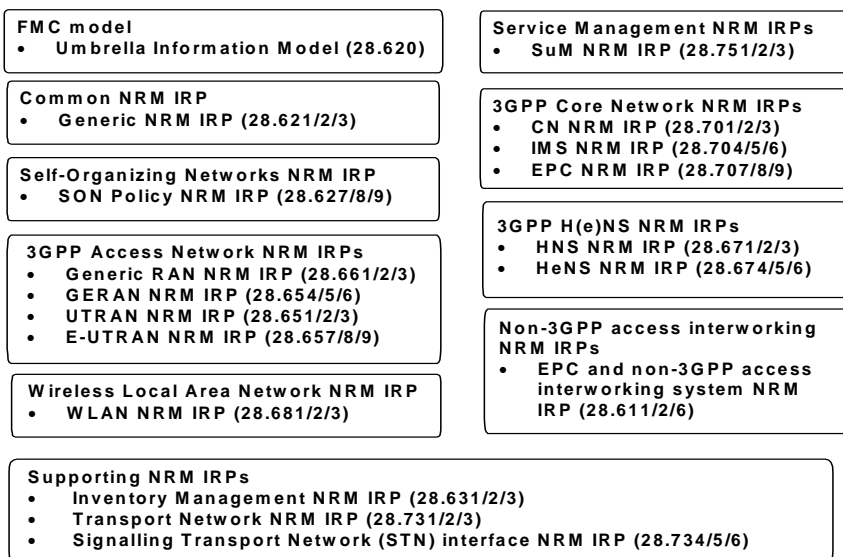

Figure 4.13.1-2: 3GPP NRM IRPs

Some interface IPR specifications (e.g. Basic CM IRP, Alarm IRP) have been developed to corresponding SBMA specifications (e.g. provision MnS, fault supervision MnS), some NRM IRP specifications (e.g. Generic NRM IRP) are reused for SBMA, there are still some IRP specifications have not produced corresponding SBMA specifications.

4.13.2 Potential solutions

Table 4.13.2-1 provides the overview analysis on 3GPP Interface IRPs and the related SBMA specifications.

Table 4.13.2-1: Overview analysis on 3GPP Interface IRPs and the related SBMA specifications

3GPP Interface IRP specifications		Whether corresponding SBMA specification is needed	Status
Generic/Common Interface IRPs	Name convention for Managed Objects (3GPP TS 32.300 [42])	Yes	The name convention is used in SBMA.
	Notification IRP (3GPP TS 32.301 [78], 3GPP TS 32.302 [79], 3GPP TS 32.306 [80])	Yes	SBMA specification is already defined (3GPP TS 28.532 [45])
	Generic IRP (3GPP TS 32.31x)	Not needed as it is management of interface IRPs	
FM related interface IRPs	Alarm IRP (3GPP TS 32.111-2 [29])	Yes	SBMA specification is already defined (3GPP TS 28.532 [45])
	Advanced Alarm Management IRP (3GPP TS 32.12x)	To be further investigated	
	Test management IRP (3GPP TS 32.32x)	discontinue MnS as there is lack of requirements	
CM related interface IRPs	Basic CM IRP (3GPP TS 32.60x)	Yes	SBMA specification is already defined (3GPP TS 28.532 [45])
	Bulk CM IRP (3GPP TS 32.61x)	Yes	YANG (IETF RFC 7950 [76]) and Netconf (IETF RFC 6241 [77]) allows updating a single boolean attribute/leaf or the whole configuration. Individual and bulk are not handled separately. Restful SBMA specification is already defined (3GPP TS 28.532 [45])
	Kernel CM IRP (3GPP TS 32.66x)	Yes	YANG (IETF RFC 7950 [76]) and Netconf (IETF RFC 6241 [77]) allows updating a single boolean attribute/leaf or the whole configuration. Individual and bulk are not handled separately. Part of operations defined in Kernel CM IRP have already a SBMA specification, e.g. notifyMOICreation, notifyMOIDeletion, etc. (see 3GPP TS 28.532 [45]).
PM file format/collection & Trace related Interface IRPs	Performance Management IRP (3GPP TS 32.41x)	Yes	SBMA specification is already defined (3GPP TS 28.532 [45] and 3GPP TS 28.550 [55])
	Performance Measurement collection (3GPP TS 32.43x)	Yes	SBMA specification is already defined (3GPP TS 28.532 [45] and 3GPP TS 28.550 [55])
	Trace Management IRP (3GPP TS 32.42x, 3GPP TS 32.44x)	Yes	Already reused for SBMA
	Notification Log IRP (3GPP TS 32.33x)	Yes	Already covered by FS_eSBMAe SID (see FS_eSBMAe_WoP#7)

3GPP Interface IRP specifications		Whether corresponding SBMA specification is needed	Status
Supporting interface IRPs	File Transfer IRP (3GPP TS 32.34x)	Yes	SBMA specification is already defined (3GPP TS 28.537 [25] and 3GPP TS 28.622 [23])
	Communication Surveillance IRP (3GPP TS 32.35x)	Yes	SBMA specification is already defined (3GPP TS 28.537 [25], 3GPP TS 28.622 [23], 3GPP TS 28.532 [45])
	Entry Point IRP 3GPP TS (32.36x)	Yes	SBMA specification is already defined (5GDMS, 3GPP TS 28.537 [25], 3GPP TS 28.622 [23])
Other interface IRPs	Partial Suspension of ltf-N IRP (3GPP TS 32.38x)	discontinue MnS as there is lack of requirements	
	Delta synchronization IRP (3GPP TS 32.39x)	discontinue MnS as there is lack of requirements	
SON related Interface IRPs	Self-Configuration IRP (3GPP TS 32.50x)	Yes	SBMA specification for PnC is already defined (3GPP TS 28.314 [56], 3GPP TS 28.315 [57] and 3GPP TS 28.316 [58]) SBMA specification for SBMA is covered by RANSC WI
	Software Management IRP (3GPP TS 32.53x)	Not addressed in the present document	Analysis is covered by Issue #6 in clause 4.6

Table 4.13.2-2 gives the overview analysis on 3GPP NRM IRPs to derive which IRP specifications needs to be convert to SBMA specifications in the future.

Table 4.13.2-2: Overview analysis on 3GPP NRM IRPs and the related SBMA specifications

3GPP NRM IRP specifications		Whether corresponding SBMA specification is needed	Status
FMC model	Umbrella Information Model (3GPP TS 28.620 [82])	Yes	Reused for SBMA
Common NRM IRP	Generic NRM IRP (3GPP TS 28.621 [43], 3GPP TS 28.622 [23], 3GPP TS 28.623 [44])	Yes	Covered by Issue #4 in clause 4.1.
3GPP Access Network (AN) related NRM IRPs	Generic RAN NRM IRP (3GPP TS 28.661 [83], 3GPP TS 28.662 [52], 3GPP TS 28.663 [84])	Yes	Covered by Issue #4 in clause 4.3
	GERAN NRM IRP (3GPP TS 28.654 [88], 3GPP TS 28.655 [89], 3GPP TS 28.656 [90])	Not applicable	
	UTRAN NRM IRP (3GPP TS 28.651 [85], 3GPP TS 28.652 [86], 3GPP TS 28.653 [87])	Not applicable	
	E-UTRAN NRM IRP (3GPP TS 28.657 [91], 3GPP TS 28.658 [92], 3GPP TS 28.659 [93])	Yes	Covered by Issue #4 in clause 4.3
	Generic RAN NRM IRP (3GPP TS 28.661 [83], 3GPP TS 28.662 [52], 3GPP TS 28.663 [84])	Yes	There is a dependency from 3GPP TS 28.541 [46] to 3GPP TS 28.662 [52]

3GPP NRM IRP specifications		Whether corresponding SBMA specification is needed	Status
3GPP Core Network (CN)/IMS related NRM IRPs	CN NRM IRP (3GPP TS 28.701 [94], 3GPP TS 28.702 [95], 3GPP TS 28.703 [96])	Not applicable	
	CN NRM IRP (3GPP TS 28.704 [97], 3GPP TS 28.705 [98], 3GPP TS 28.706 [99])	Not applicable	
	EPC NRM IRP (3GPP TS 28.707 [100], 3GPP TS 28.708 [101], 3GPP TS 28.709 [102])	Not applicable	
3GPP H(e)NB related NRM IRPs	HNS NRM IRP (3GPP TS 28.671 [103], 3GPP TS 28.672 [104], 3GPP TS 28.673 [105])	Not applicable	
	HeNS NRM IRP (3GPP TS 28.674 [106], 3GPP TS 28.675 [107], 3GPP TS 28.676 [108])	Not applicable	
Service management related NRM IRPs	SuM NRM IRP (3GPP TS 28.751 [109], 3GPP TS 28.752 [110], 3GPP TS 28.753 [111])	discontinue MnS as there is lack of operators requirements.	
Supporting NRM IRPs	Inventory Management NRM IRP (3GPP TS 28.631 [34], 3GPP TS 28.632 [35], 3GPP TS 23.633 [36])	Yes	Covered by Issue #7 in clauses 4.7 and 5.4. They are already included in (informative) annex E in 3GPP TS 28.533 [2] about 5G specifications though still lacking SBMA-compatible solution set
	Transport Network NRM IRP (3GPP TS 28.731 [112], 3GPP TS 28.732 [113], 3GPP TS 28.733 [114])	Not applicable	
	Signalling Transport NW IF NRM IRP (3GPP TS 28.734 [115], 3GPP TS 28.735 [116], 3GPP TS 28.736 [117])	Not applicable	
	State management data definition IRP (3GPP TS 28.624 [118], 3GPP TS 28.625 [119])	Yes	Most of the relevant contents from 3GPP TS 28.625 [81] have been copied into 3GPP TS 28.622 [23] and 3GPP TS 28.541 [46].
Self-Organizing Networks NRM IRPs	SON Policy NRM IRP (3GPP TS 28.627 [120], 3GPP TS 28.628 [121], 3GPP TS 28.629 [122])	Not applicable	
Non-3GPP access interworking NRM IRPs	EPC and non-3GPP access interworking system Network Resource Model (NRM) IRP (3GPP TS 28.611 [123], 3GPP TS 28.612 [124], 3GPP TS 28.616 [125])	Not applicable	
Wireless Local Area Network NRM IRP	WLAN NRM IRP (3GPP TS 28.681 [126], 3GPP TS 28.682 [127], 3GPP TS 28.683 [128])	Not applicable	

4.14 Issue #14: Providing a usage guide for SBMA series of specifications

4.14.1 Description

3GPP TS 32.103 [24] has captured the Telecommunication management; Integration Reference Point (IRP) overview and usage guide for managing of 2G, UMTS and LTE network. The usage guide in 3GPP TS 32.1032 [24] is very useful for external readers to get an overview of how IRP series of specifications.

4.14.2 Potential solutions

It is recommended to create a new specification to capture the overview and usage guide information for SBMA series of specifications.

4.15 Issue# 15: Extend 3GPP TS 32.300 to support SBMA

4.15.1 Description

3GPP TS 32.300 [42] is written for IRP based architecture, the same level information is also needed for 5G/SBMA. To extend the support to SBMA, there are issues which need to be resolved:

- 1) The scope of the present document is set to IRP, e.g. in clause 1 scope.
- 2) There are specific references to IRP specifications, e.g. in the definitions, abbreviations, and clause 7.4 refers to 3GPP TS 32.103 [24] for IRP, etc.
- 3) Some contents are limited to IRP scope, e.g. some statements are prefixed with IRP.
- 4) There are references to IRP SS, XML.

4.15.2 Potential solutions

The following changes are needed to support SBMA:

- Update the scope to be generic applicable to both IRP and SBMA.
- Complement the existing reference to IRP specifications, the same level information shall be extended for SBMA, e.g. clause 7.4 of 3GPP TS 32.103 [24].
- For the content and statement that are limited to IRP scope, they shall be lifted to support SBMA. e.g. clauses 4, 5 and 6 of 3GPP TS 32.300 [42].
- For those specific references to IRP SS, make them to be generic applicable to both IRP and SBMA. e.g. clauses 6 and 7 of 3GPP TS 32.300 [42].

5 Conclusion and Recommendation

5.1 Issue #1 Scope of specifications

5.1.1 Solution #1-1 scope of 3GPP TS 28.533

It is recommended to not pursue the solution#1-1.

5.1.2 Solution #1-2 SBMA for Generic NRM

5.1.2.1 Issue #1-2.a: No requirements specification generic NRM for SBMA

From Rel-19 and later releases, solution #1.2.c is recommended for normative work. Solution #1.2.e may be applied.

For Rel-15 - 18 solution #1.2.d is recommended for normative work as maintenance work in Rel-15 to Rel-18.

5.1.2.2 Issue #1-2.b: Scope of 3GPP 3GPP TS 28.622

From Rel-19 and later releases, solution #1-2.h is recommended for normative work. Solution #1-2.j may be applied.

For Rel-15 - 18 solution #1-2.i is recommended for normative work as maintenance work in Rel-18.

NOTE: There are ongoing working items in SA5, e.g. S5-232083 DP on restructuring 3GPP TS 28.545 [54], which may have impacts on the detail steps of this this solution.

5.1.2.3 Issue #1.2.c: No clear solution set definition for generic NRM in SBMA

From Rel-19 and later releases, solution #1-2.m is recommended for normative work. Solution #1-2.o may be applied.

For Rel-15 - 18 solution #1-2.n is recommended for normative work as maintenance work in Rel-18.

5.1.3 Solution #1-3 scope of referred 3GPP TSs in 3GPP TS 28.533

It is recommended to not pursue the solution#1-3.

5.1.4 Solution #1-4 new SBMA TS for Generic RAN NRM

Replace 3GPP TS 28.662 [52] with a new 5G TS for SBMA, including stage 1, 2 and 3.

5.2 Issue #2 Content errors

It is recommended that the errors are corrected by maintenance CRs.

5.3 Issue #3 Reference errors

5.3.1 Solution #3-1 Make not used references void

It is recommended to:

- a) Make the reference to 3GPP TS 32.101 [3] void in 3GPP TS 28.533 [2].

As a maintenance CR.

5.4 Issue #4 SBMA supporting management of 5G SA and NSA scenarios

Two management options are identified for 5G SA and NSA in clause 4.4.2.

It is recommended that the NG-RAN management Option#2 is to be supported by specifying YANG and YAML solution sets in a new TS. It may be an own stage 3 TS or included in the stage 2 TS.

5.5 Issue #5: SBMA supporting management architecture and frameworks in other SDOs

3GPP SBMA is aligned with ZSM framework reference architecture, and related description is captured in 3GPP TS 28.533 [2]. No further modification is needed to existing specifications.

5.6 Issue #6: Software management feature in SBMA for 5G

The SBMA software management solution is not addressed in the present document due to lack of requirements.

5.7 Issue #7 Inventory missing in 5G

Replace 3GPP TS 28.631 [34], 3GPP TS 28.632 [35] and 3GPP TS 28.633 [36] with one or several new 5G TSs for SBMA for stage 1, 2 and 3.

Propose a Work Item to include inventory NRM in SBMA.

5.8 Issue #8: Use of Models in SBMA

It is recommended to add IOC summary in 3GPP TS 28.533 [2] Annex E (informative): 5G specifications overview to provide the overview of IOC information which currently captured in multiple specifications. The following grouping could be considered as starting inputs:

- 1) IOCs representing network resources as defined in SA2 and RAN3 (e.g. Network Element, Network Function).
- 2) IOCs representing Management of D-SON functions as shown in clause 4.8.2.
- 3) IOCs representing Management of management functions as shown in clause 4.8.2.

5.9 Issue #9: Improvement on the management function description

It is recommended to consider the descriptions in 3GPP TS 32.101 [3] clause 7 where applicable.

5.10 Issue #10: Use of 3GPP TS 32.401 in SBMA

Replace 3GPP TS 32.401 [38] with a new 5G TS for SBMA.

5.11 Issue #11: Use of 3GPP TS 32.404 in SBMA

Update 3GPP TS 32.404 [39] to include SBMA.

5.12 Issue#12: illustration of using MnS in management reference model in 3GPP TS 32.101

A MnS is a set of offered capabilities for management and orchestration of network and services, SBMA provides the following flexibility:

- 1) SBMA does not limit who can play the role of an MnS consumer. Any entities consume SA5 defined MnS are called MnF.
- 2) Depending on different scenarios, an entity either plays the role as MnS producers or as MnS consumers.

It is recommended to add examples of using MnS in different scenarios to illustrate the flexibility of Service Based Management Architecture (SBMA).

5.13 Issue #13: Analysis on management features for SBMA support

The list below identifies management features in IRP framework that have similar functionality supported in SBMA:

For management operations related:

- Name convention for Managed Objects
- Notification.
- Alarm
- Basic CM
- Bulk CM
- Kernel CM
- Performance Management
- Performance Measurement collection
- Trace Management
- File Transfer
- Communication Surveillance
- Entry Point

For NRM related:

- Umbrella Information Model
- Generic NRM
- Generic RAN NRM
- E-UTRAN NRM
- Generic RAN NRM
- State management data definition

The list below identifies management features in IRP framework that have similar functionality to be supported in SBMA:

For management operations related:

- Notification Log
- Self-Configuration

For NRM related:

- Inventory Management NRM

5.14 Issue #14: Providing overview for SBMA series of specifications

SBMA related management features are currently documented in multiple specifications. An overview including the high level summary description and dependency relationship between multiple specifications could help readers to get full picture of series of SBMA specifications.

It is recommended to create a new specification to capture the overview for SBMA series of specifications.

Annex A:

Change history

Change history							
Date	Meeting	TDoc	CR	Rev	Cat	Subject/Comment	New version
04-2021	SA5#137e	S5-213042				Initial skeleton	0.0.0
04-2021	SA5#137e	S5-213043				Correction on title	0.0.1
05-2021	SA5#137e	S5-213572 S5-213573 S5-213574				Update approved tdocs in SA5#137e	0.1.0
09-2021	SA5#138e	S5-214451 S5-214649				First conclusions for 28.533 First conclusion for NSA	0.2.0
10-2021	SA5#139e	S5-215617 S5-215618				Update approved tdocs in SA5#139e: Add key issue on software management feature in SBMA for 5G Inventory for 5G	0.3.0
11-2021	SA5#140e	S5-216235 S5-216594				Add potential solution and conclusion for Issue#5 Add key issue on modelling of MnF	0.4.0
04-2022	SA5#142e	S5-222629 S5-222630				Add issue on the applicable content from TS 32.101 section 7 Proposal to update 32.401 and 32.404 for SBMA	0.5.0
05-2022	SA5#143e	S5-223579 S5-223581				Add issue on illustration of using MnS in management reference model in TS 32.101. Add issue on analysis on IRP specifications needs to support SBMA.	0.6.0
07-2022	SA5#144e	S5-224160				Add conclusion for overview and usage guide for SBMA specifications	0.7.0
07-2022	SA5#145e	S5-225799 S5-225800 S5-225670				Update of the TR 28.925, due to the study being moved to Rel-18 and new proposals pCR TR28.925 Add conclusion for issue #14 pCR TR28.925 Add description on MnFs to be managed	0.8.0
11-2022	SA5#146	S5-226236 S5-226963				rapportuer reorganizing modification for section 5 Add conclusion for issue 4.8	0.9.0
03-2023	SA5#147	S5-232317 S5-232952 S5-232953				pCR TR 28.925 Rapporteur cleanup pCR 28.925 Add an example for management function deployment scenarios pCR TR 28.925 Add issue about extending TS 32.300 to support SBMA editorial update.	0.a.0
05-2023	SA5#149	S5-234843 S5-234509 S5-234510 S5-234277 S5-234512 S5-234513 S5-234514 S5-234515 S5-234516 S5-234517 S5-234518 S5-234519 S5-234520 S5-234274 S5-234521 S5-234511				S5-234843 pCR TR 28.925 Add conclusion and recommendation for issue#9 Improvement on the management function description S5-234509 pCR TR 28.925 Update solution and add conclusion and recommendation for issue#12 illustration of using MnS in management reference model in TS 32.101 S5-234510 pCR TR 28.925 Update solution and add conclusion and recommendation for issue#13 Analysis on IRP specification needs to support SBMA S5-234277 Conclusion for issue 2 S5-234512 pCR 28.925 Issue description for 28.621 S5-234513 pCR 28.925 Solution description for 28.621 S5-234514 pCR 28.925 Conclusion for 28.621 S5-234515 pCR 28.925 Issue description for 28.622 S5-234516 pCR 28.925 Solution description for 28.622 S5-234517 pCR 28.925 Conclusion for 28.622 S5-234518 pCR 28.925 Issues for 28.623 S5-234519 pCR 28.925 Solution description for 28.623 S5-234520 pCR 28.925 Conclusion for 28.623 S5-234274 Removal of Editor's note in 28.925-0a0 S5-234521 pCR TR 28.925 Add overview for management service features supported by CRUD operations in SBMA S5-234511 pCR TR 28.925 Add conclusion and recommendation for issue#6 software management feature in SBMA for 5G Add references information for 28.621/28.623/28.532/28.541/28.104/28.105/28.536/28.312/28.538/28.662	0.b.0
2023-09	SA#101	SP-230930				Presented for information and approval	1.0.0
2023-09	SA#101					EditHelp review and upgrade to change control version	18.0.0

History

Document history		
V18.0.0	May 2024	Publication