

ETSI TS 102 226 V19.0.0 (2025-11)



TECHNICAL SPECIFICATION

Smart Cards; Remote APDU structure for UICC based applications (Release 19)

Reference

RTS/SET-T102226vj00

Keywords

protocol, smart card

ETSI

650 Route des Lucioles
F-06921 Sophia Antipolis Cedex - FRANCE

Tel.: +33 4 92 94 42 00 Fax: +33 4 93 65 47 16

Siret N° 348 623 562 00017 - APE 7112B
Association à but non lucratif enregistrée à la
Sous-Préfecture de Grasse (06) N° w061004871

Important notice

The present document can be downloaded from the
[ETSI Search & Browse Standards](#) application.

The present document may be made available in electronic versions and/or in print. The content of any electronic and/or print versions of the present document shall not be modified without the prior written authorization of ETSI. In case of any existing or perceived difference in contents between such versions and/or in print, the prevailing version of an ETSI deliverable is the one made publicly available in PDF format on [ETSI deliver](#) repository.

Users should be aware that the present document may be revised or have its status changed,
this information is available in the [Milestones listing](#).

If you find errors in the present document, please send your comments to
the relevant service listed under [Committee Support Staff](#).

If you find a security vulnerability in the present document, please report it through our
[Coordinated Vulnerability Disclosure \(CVD\)](#) program.

Notice of disclaimer & limitation of liability

The information provided in the present deliverable is directed solely to professionals who have the appropriate degree of experience to understand and interpret its content in accordance with generally accepted engineering or other professional standard and applicable regulations.

No recommendation as to products and services or vendors is made or should be implied.

No representation or warranty is made that this deliverable is technically accurate or sufficient or conforms to any law and/or governmental rule and/or regulation and further, no representation or warranty is made of merchantability or fitness for any particular purpose or against infringement of intellectual property rights.

In no event shall ETSI be held liable for loss of profits or any other incidental or consequential damages.

Any software contained in this deliverable is provided "AS IS" with no warranties, express or implied, including but not limited to, the warranties of merchantability, fitness for a particular purpose and non-infringement of intellectual property rights and ETSI shall not be held liable in any event for any damages whatsoever (including, without limitation, damages for loss of profits, business interruption, loss of information, or any other pecuniary loss) arising out of or related to the use of or inability to use the software.

Copyright Notification

No part may be reproduced or utilized in any form or by any means, electronic or mechanical, including photocopying and microfilm except as authorized by written permission of ETSI.

The content of the PDF version shall not be modified without the written authorization of ETSI.

The copyright and the foregoing restriction extend to reproduction in all media.

© ETSI 2025.
All rights reserved.

Contents

Intellectual Property Rights	5
Foreword.....	5
Modal verbs terminology.....	6
1 Scope	7
2 References	7
2.1 Normative references	7
2.2 Informative references.....	8
3 Definition of terms, symbols and abbreviations.....	9
3.1 Terms.....	9
3.2 Symbols.....	9
3.3 Abbreviations	9
4 Overview of remote management	10
5 Remote APDU format.....	11
5.1 Compact Remote Application data format	11
5.1.1 Compact Remote command structure	11
5.1.2 Compact Remote response structure.....	12
5.2 Expanded Remote Application data format.....	12
5.2.1 Expanded Remote command structure	12
5.2.1.0 Structure overview	12
5.2.1.1 C-APDU TLV	13
5.2.1.2 Immediate Action TLV	13
5.2.1.3 Error Action TLV.....	14
5.2.1.4 Script Chaining TLV	15
5.2.2 Expanded Remote response structure	16
5.3 Automatic application data format detection.....	19
6 Security parameters assigned to applications	19
6.1 Minimum Security Level (MSL).....	19
6.2 Access domain.....	19
7 Remote File Management (RFM)	19
7.0 RFM basic principles.....	19
7.1 Commands.....	20
7.2 UICC Shared File System Remote File Management	21
7.3 ADF Remote File Management.....	21
7.4 RFM implementation over HTTPS	21
8 Remote Application Management (RAM).....	22
8.0 RAM basic principles.....	22
8.1 Remote application management application behaviour	22
8.2 Command coding and description	23
8.2.0 Basic rules.....	23
8.2.1 Commands	23
8.2.1.0 Application management commands overview.....	23
8.2.1.1 DELETE	23
8.2.1.2 SET STATUS	23
8.2.1.3 INSTALL.....	24
8.2.1.3.0 Basic requirements for INSTALL command.....	24
8.2.1.3.1 INSTALL [for load]	24
8.2.1.3.2 INSTALL [for install]	24
8.2.1.4 LOAD	32
8.2.1.5 PUT KEY	32
8.2.1.5.0 Generic rules for PUT KEY command.....	32
8.2.1.5.1 PUT KEY for AES	32
8.2.1.5.2 PUT KEY for triple DES (deprecated).....	33

8.2.1.6	GET STATUS.....	33
8.2.1.6.0	Basic rules	33
8.2.1.6.1	Menu parameters	34
8.2.1.7	GET DATA.....	34
8.2.1.7.0	Basic rules	34
8.2.1.7.1	Void.....	35
8.2.1.7.2	Extended Card resources information	35
8.2.1.8	STORE DATA.....	35
8.3	RAM implementation over HTTPS.....	36
9	Additional command for push.....	36
9.0	Introduction	36
9.1	Push command behaviour	36
9.1.1	Request for open channel.....	36
9.1.2	Request for CAT_TP link establishment	36
9.1.3	Behaviour for responses.....	36
9.1.4	Request for TCP connection	37
9.1.5	Request for Identification Packet.....	37
9.2	Commands coding.....	37
9.2.0	Coding	37
9.2.1	Data for BIP channel opening.....	37
9.2.2	Data for CAT_TP link establishment.....	38
9.2.3	Data for TCP connection opening.....	38
9.2.4	Data for sending of Identification Packet	39
9.3	Closing of the BIP channel.....	39
10	Confidential application management.....	40
10.0	Overview and basic requirements.....	40
10.1	Confidential loading	40
10.2	Additional application provider security	40
10.3	Confidential setup of Security Domains.....	41
10.4	Application personalization in an APSD.....	41
Annex A (normative):	BER-TLV tags.....	42
Annex B (informative):	RFM over HTTP Communication Flow	43
Annex C:	Void	45
Annex D (informative):	RFM over CoAP/DTLS Communication Flow	46
Annex E (informative):	RAM over CoAP/DTLS Communication Flows	47
E.1	Communication Flow between an AP (Owning a RAS) and its APSD	47
E.2	Communication Flow between an AP and its APSD through a Third Party RAS	48
Annex F (informative):	Change history	50
History		54

Intellectual Property Rights

Essential patents

IPRs essential or potentially essential to normative deliverables may have been declared to ETSI. The declarations pertaining to these essential IPRs, if any, are publicly available for **ETSI members and non-members**, and can be found in ETSI SR 000 314: "*Intellectual Property Rights (IPRs); Essential, or potentially Essential, IPRs notified to ETSI in respect of ETSI standards*", which is available from the ETSI Secretariat. Latest updates are available on the [ETSI IPR online database](#).

Pursuant to the ETSI Directives including the ETSI IPR Policy, no investigation regarding the essentiality of IPRs, including IPR searches, has been carried out by ETSI. No guarantee can be given as to the existence of other IPRs not referenced in ETSI SR 000 314 (or the updates on the ETSI Web server) which are, or may be, or may become, essential to the present document.

Trademarks

The present document may include trademarks and/or tradenames which are asserted and/or registered by their owners. ETSI claims no ownership of these except for any which are indicated as being the property of ETSI, and conveys no right to use or reproduce any trademark and/or tradename. Mention of those trademarks in the present document does not constitute an endorsement by ETSI of products, services or organizations associated with those trademarks.

DECT™, **PLUGTESTS™**, **UMTS™** and the ETSI logo are trademarks of ETSI registered for the benefit of its Members. **3GPP™**, **LTE™** and **5G™** logo are trademarks of ETSI registered for the benefit of its Members and of the 3GPP Organizational Partners. **oneM2M™** logo is a trademark of ETSI registered for the benefit of its Members and of the oneM2M Partners. **GSM®** and the GSM logo are trademarks registered and owned by the GSM Association.

Foreword

This Technical Specification (TS) has been produced by ETSI Technical Committee Secure Element Technologies (SET).

It is based on work originally done in the 3GPP in TSG-terminals WG3 and ETSI SMG.

The contents of the present document are subject to continuing work within TC SET and may change following formal TC SET approval. If TC SET modifies the contents of the present document, it will then be republished by ETSI with an identifying change of release date and an increase in version number as follows:

Version x.y.z

where:

- x: the first digit:
 - 0 early working draft;
 - 1 presented to TC SET for information;
 - 2 presented to TC SET for approval;
 - 3 or greater indicates TC SET approved document under change control.
- y: the second digit is incremented for all changes of substance, i.e. technical enhancements, corrections, updates, etc.
- z: the third digit is incremented when editorial only changes have been incorporated in the document.

Modal verbs terminology

In the present document "**shall**", "**shall not**", "**should**", "**should not**", "**may**", "**need not**", "**will**", "**will not**", "**can**" and "**cannot**" are to be interpreted as described in clause 3.2 of the [ETSI Drafting Rules](#) (Verbal forms for the expression of provisions).

"**must**" and "**must not**" are **NOT** allowed in ETSI deliverables except when used in direct citation.

1 Scope

The present document defines the remote management of the UICC based on any of the secured packet structures specified in ETSI TS 102 225 [1].

It specifies the APDU format for remote management.

Furthermore the present document specifies:

- A set of commands coded according to this APDU structure and used in the remote file management on the UICC. This is based on ETSI TS 102 221 [2].
- A set of commands coded according to this APDU structure and used in the remote application management on the UICC. This is based on the GlobalPlatform Card Specification [4], its Amendments and Configuration documents.

2 References

2.1 Normative references

References are either specific (identified by date of publication and/or edition number or version number) or non-specific. For specific references, only the cited version applies. For non-specific references, the latest version of the referenced document (including any amendments) applies.

- In the case of a reference to a TC SET document, a non-specific reference implicitly refers to the latest version of that document in the same Release as the present document.

Referenced documents which are not found to be publicly available in the expected location might be found in the [ETSI docbox](#).

NOTE: While any hyperlinks included in this clause were valid at the time of publication, ETSI cannot guarantee their long term validity.

The following referenced documents are necessary for the application of the present document.

- [1] [ETSI TS 102 225](#): "Smart Cards; Secured packet structure for UICC based applications".
- [2] [ETSI TS 102 221](#): "Smart Cards; UICC-Terminal interface; Physical and logical characteristics".
- [3] [ETSI TS 102 223](#): "Smart Cards; Card Application Toolkit (CAT)".
- [4] GlobalPlatform: "[GlobalPlatform Card Specification v2.3.1](#)".
- [5] [ETSI TS 101 220](#): "Smart Cards; ETSI numbering system for telecommunication application providers".
- [6] [ETSI TS 102 241](#): "Smart Cards; UICC Application Programming Interface (UICC API) for Java Card™".
- [7] Void.
- [8] Void.
- [9] [ETSI TS 102 222](#): "Integrated Circuit Cards (ICC); Administrative commands for telecommunications applications".
- [10] [ETSI TS 123 048](#): "Digital cellular telecommunications system (Phase 2+); Universal Mobile Telecommunications System (UMTS); Security mechanisms for the (U)SIM application toolkit; Stage 2".
- [11] [ETSI TS 102 127](#): "Smart Cards; Transport protocol for CAT applications; Stage 2".

- [12] [ETSI TS 143 019](#): "Digital cellular telecommunications system (Phase 2+); Subscriber Identity Module Application Programming Interface (SIM API) for Java Card; Stage 2".
- [13] [FIPS-197 \(2001\)](#): "Advanced Encryption Standard (AES)".
- [14] [NIST Special Publication 800-38A \(2001\)](#): "Recommendation for Block Cipher Modes of Operation - Methods and Techniques".
- [15] [NIST Special Publication 800-38B \(May 2005 including updates as of 10-06-2016: PAGE II\)](#): "Recommendation for Block Cipher Modes of Operation: The CMAC Mode for Authentication".
- [16] GlobalPlatform: "[UICC Configuration v2.0](#)".
- [17] [ETSI TS 102 588](#): "Smart Cards; Application invocation Application Programming Interface (API) by a UICC webserver for Java Card™ platform".
- [18] GlobalPlatform: "[GlobalPlatform Technology, Confidential Card Content Management Card Specification v2.3 - Amendment A](#)", Version 1.2.
- [19] GlobalPlatform: "[GlobalPlatform Card, Remote Application Management over HTTP, Card Specification v2.2 - Amendment B](#)", Version 1.2.
- [20] [ETSI TS 102 483](#): "Smart cards; UICC-Terminal interface; Internet Protocol connectivity between UICC and terminal".
- [21] [ISO/IEC 8825-1](#): "Information technology - ASN.1 encoding rules - Part 1: Specification of Basic Encoding Rules (BER), Canonical Encoding Rules (CER) and Distinguished Encoding Rules (DER)".
- [22] GlobalPlatform: "[GlobalPlatform Technology, Contactless Services, Card Specification v2.3 - Amendment C](#)", Version 1.3.
- [23] [ETSI TS 102 622](#): "Smart Card; UICC - Contactless Front-end (CLF) Interface; Host Controller Interface (HCI)".
- [24] Void.
- [25] GlobalPlatform: "[GlobalPlatform Card API \(org.globalplatform\)](#)", Version 1.7.1.
- [26] GlobalPlatform: "[GlobalPlatform Card Technology, Secure Channel Protocol '03', Card Specification v2.3 - Amendment D](#)", Version 1.2.
- [27] GlobalPlatform: "[GlobalPlatform Card, Common Implementation Configuration](#)", Version 2.1.
- [28] [ETSI TS 102 705](#): "Smart Cards; UICC Application Programming Interface for Java Card™ for Contactless Applications".
- [29] GlobalPlatform: "[Remote Application Management over CoAP, Card Specification v2.3 - Amendment M](#)", Version 1.0.

2.2 Informative references

References are either specific (identified by date of publication and/or edition number or version number) or non-specific. For specific references, only the cited version applies. For non-specific references, the latest version of the referenced document (including any amendments) applies.

- In the case of a reference to a TC SET document, a non-specific reference implicitly refers to the latest version of that document in the same Release as the present document.

NOTE: While any hyperlinks included in this clause were valid at the time of publication, ETSI cannot guarantee their long term validity.

The following referenced documents may be useful in implementing an ETSI deliverable or add to the reader's understanding, but are not required for conformance to the present document.

Not applicable.

3 Definition of terms, symbols and abbreviations

3.1 Terms

For the purposes of the present document, the terms given in ETSI TS 102 225 [1], ETSI TS 101 220 [5] and the following apply:

Controlling Authority Security Domain (CASD): security domain providing cryptographic functions, as specified in GlobalPlatform Card Specification Amendment A [18]

NOTE: It provides services to confidentially load or generate Secure Channel keys of an APSD.

3.2 Symbols

Void.

3.3 Abbreviations

For the purposes of the present document, the abbreviations given in ETSI TS 102 225 [1] and the following apply:

ACK	ACKnowledge
ADD	Access Domain Data
ADF	Application Data File
ADP	Access Domain Parameter
AES	Advanced Encryption Standard
AFI	Application Family Identifier
AID	Application Identifier
AM	Authorized Management
AP	Application Provider
APDU	Application Protocol Data Unit
API	Application Programming Interface
APSD	Application Provider Security Domain
BER-TLV	Basic Encoding Rules - Tag, Length, Value
BIP	Bearer Independent Protocol
C-APDU	Command Application Protocol Data Unit
CASD	Controlling Authority Security Domain
CAT_TP	Card Application Toolkit Transport Protocol
CBC	Cell Broadcast Centre
CC	Cryptographie Checksum
CL	ContactLess
CLA	CLAss
CLT	ContactLess Tunnelling
CMAC	Cipher-based Message Authentication Code
CoAP	Constrained Application Protocol
DAP	Data Authentication Pattern
DEK	Data Encryption Key
DES	Data Encryption Standard
DF	Directory File
DM	Delegated Management
DS	Digital Signature
DTLS	Datagram Transport Layer Security
ECB	Electronic Code Book
ECKA	Elliptic Curve Key Agreement algorithm

ECKA-EG	ElGamal ECKA
EF	Elementary File
HTTP	HyperText Transfer Protocol
HTTPS	HyperText Transfer Protocol Secure
ICCID	Integrated Circuit Card IDentification
ICV	Integrity Check Value
INS	INStruction
IP	Internet Protocol
ISD	Issuer Security Domain
KIc	Key and algorithm Identifier for ciphering
KID	Key and algorithm IDentifier for RC/CC/DS
MAC	Message Authentication Code
MF	Management Field
MSL	Minimum Security Level
MSLD	Minimum Security Level Data
NIST	National Institute of Standards and Technology
OTA	Over The Air
PDU	Packet Data Unit
PIN	Personal Identification Number
RAM	Remote Application Management
R-APDU	Response Application Protocol Data Unit
RF	Radio Frequency
RFM	Remote File Management
RFU	Reserved for Future Use
SCP02	Secure Channel Protocol 02
SCP03	Secure Channel Protocol 03
SD	Security Domain
SDU	Service Data Unit
SE	Sending Entity
SMG	Special Mobile Group
SP	Special Publication
SPI	Security Parameter Indication
TAR	Toolkit Application Reference
TCP	Transmission Control Protocol
TLS	Transport Layer Security
TLV	Tag Length Value
TPDU	Transfer Protocol Data Unit
UDP	User Datagram Protocol

4 Overview of remote management

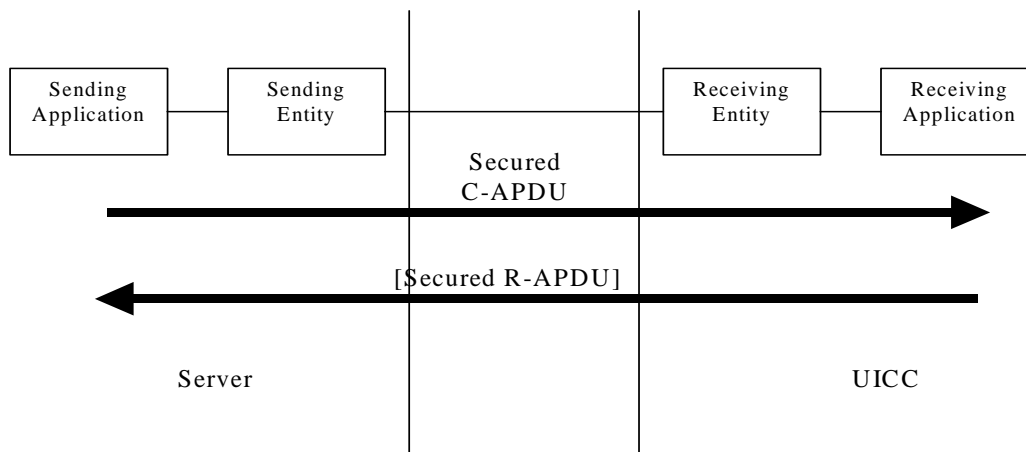

Figure 4.1: Remote management

All data exchanged between the Sending Entity and Receiving Entity shall be formatted as "Secured data" according to ETSI TS 102 225 [1]:

- 1) The parameter(s) (the command string) in the "Secured data" is either a single command, or a list of commands, which shall be processed sequentially. Additional application provider security may be applied to the "secured data" as specified in clause 10.2 of the present document.
- 2) The Remote Management application shall take parameters from the "Secured data" and shall act upon the files or applications or perform other actions according to these parameters. A Remote Management application is the on-card Receiving Application that performs either Remote File Management (RFM) or Remote Application Management (RAM) as defined in the following clauses.
- 3) Remote Management commands shall be executed by the dedicated Remote Management Application. A "Command session" is defined as starting upon receipt of the parameter/command list, and ends when the parameter list in the "Secured data" is completed, or when an error (i.e. SW1 of the command indicates an error condition) is detected which shall halt further processing of the command list. Warnings or procedure bytes do not halt processing of the command list. Such a "Command session" shall be handled like an application session defined in ETSI TS 102 221 [2] (for RFM) and GlobalPlatform Card Specification [4] (for RAM). Application selection at the beginning of the session happens implicitly based on the header information (TAR, HTTP header field X-Admin-Targeted-Application for SCP81 or SCP82-Targeted-Application in the CoAP option SCP82-Params). Unless defined otherwise in the present document, the session context shall be deleted when the "Command session" ends.
- 4) At the beginning and end of a Command "session" the logical state of the UICC as seen from the terminal shall not be changed to an extent sufficient to disrupt the behaviour of the terminal. If changes in the logical state have occurred that the terminal needs to be aware of, the application on the UICC may issue a REFRESH command according to ETSI TS 102 223 [3].

The processing of the security in the Receiving Entity according to ETSI TS 102 225 [1] and according to the present document is one of the tasks of a Security Domain according to GlobalPlatform Card Specification [4].

The mechanism defined above (addressing and selection based on TAR, HTTP header field X-Admin-Targeted-Application for SCP81 or SCP82-Targeted-Application in the CoAP option SCP82-Params) can also be used to send data to a Receiving Application which is not a Remote Management Application. In this case the format of the data exchanged between Sending Application and Receiving Application is application specific and not defined in the present document.

5 Remote APDU format

5.1 Compact Remote Application data format

5.1.1 Compact Remote command structure

A command string may contain a single command or a sequence of commands. The structure of each command shall be according to the generalized structure defined below; each element other than the Data field is a single octet (see ETSI TS 102 221 [2]).

The format of the commands is the same as the one defined in ETSI TS 102 221 [2] for T = 0 TPDU commands.

Class byte (CLA)	Instruction code (INS)	P1	P2	P3	Data
------------------	------------------------	----	----	----	------

If the sending application needs to retrieve the Response parameters/data of a case 4 command, then a GET RESPONSE command shall follow this command in the command string.

The GET RESPONSE command and any case 2 command (e.g. READ BINARY and READ RECORD) shall only occur once in a command string. If it shall be the last command in the command string. The support for BER-TLV files, i.e. support of the commands RETRIEVE DATA and SET DATA, is optional for the UICC.

NOTE: A sending application should not use the commands RETRIEVE DATA and SET DATA in a command string using the Compact Remote command structure.

For all case 2 commands and for the GET RESPONSE command, if P3 = '00', then the UICC shall send back all available response parameters/data e.g. if a READ RECORD command has P3 = '00' the whole record shall be returned. The limitation of 256 bytes does not apply for the length of the response data. In case the data is truncated in the response, the remaining bytes are lost and the status word shall be set to '62 F1'.

5.1.2 Compact Remote response structure

If a proof of Receipt is required by the sending entity, the Additional Response Data sent by the Remote Management Application shall be formatted according to table 5.1.

Table 5.1: Format of additional response data

Length	Name
1	Number of commands executed within the command script (see note)
2	Status bytes or '61 xx' procedure bytes of last executed command/GET RESPONSE
X	Response data of last executed command/GET RESPONSE if available (i.e. if the last command was a case 2 command or a GET RESPONSE)
NOTE:	This field shall be set to '01' if one command was executed within the command script, '02' if two commands were executed, etc.

5.2 Expanded Remote Application data format

5.2.1 Expanded Remote command structure

5.2.1.0 Structure overview

The "Secured data" sent to a Remote Management Application shall be a BER-TLV data object formatted according to table 5.2.

Two variants exist for the expanded remote command structure:

- The Command Scripting template is a BER-TLV data object as defined in ETSI TS 101 220 [5], i.e. it uses definite length coding; see table 5.2.
- The Command Scripting template is a BER-TLV data object which uses indefinite length coding as defined in ISO/IEC 8825-1 [21]; see table 5.2a.

NOTE: The variant with indefinite length coding is recommended to be used for RAM/RFM over HTTPS and RAM/RFM over CoAP/DTLS.

The tags of these TLVs are defined in annex A.

Table 5.2: Expanded format of Remote Management application command "secured data" - definite length coding

Length in bytes	Name
1	Command Scripting template tag for definite length coding
L	Length of Command Scripting template = A+B+...C
A	Command TLV
B	Command TLV
	...
C	Command TLV

Table 5.2a: Expanded format of Remote Management application command "secured data" - indefinite length coding

Length in bytes	Name
1	Command Scripting template tag for indefinite length coding
1	Indicator for indefinite length coding (value '80')
A	Command TLV
B	Command TLV
	...
C	Command TLV
2	End of content indicator (value '00 00')

A Remote Management application command string may contain a single or several Command TLVs.

A Command TLV can be one of the following:

- A C-APDU, containing a remote management command.
- An Immediate Action TLV, containing a proactive command or another action to be performed when it is encountered while processing the sequence of Command TLVs.
- An Error Action TLV, containing a proactive command to be performed only if an error is encountered in a C-APDU following this TLV.
- A script Chaining TLV as first Command TLV.

5.2.1.1 C-APDU TLV

The structure of each C-APDU shall be a TLV structure coded according to the C-APDU COMPREHENSION-TLV data object coding defined in ETSI TS 102 223 [3]. The restriction on the length of the C-APDU mentioned in the note in ETSI TS 102 223 [3] shall not apply.

For all case 2 and case 4 C-APDUs, if Le='00' in the C-APDU, then the UICC shall send back all available response parameters/data in the R-APDU e.g. if a READ RECORD command has Le='00' the whole record shall be returned. The limitation of 256 bytes does not apply for the length of the response data.

In case the data is truncated in the response of a C-APDU, the status words for this C-APDU shall be set to '62 F1' in the corresponding R-APDU. This shall terminate the processing of the command list.

If a R-APDU fills the response buffer so that no further R-APDU can be included in the response scripting template, this shall terminate the processing of the command list.

If Le field is empty in the C-APDU, then no response data is expected in the R-APDU and in case of expanded format with definite length coding, no R-APDU shall be returned by the UICC in the application additional response data except if the corresponding C-APDU is the last command executed in the script.

NOTE: In this expanded format the GET RESPONSE command is not used.

5.2.1.2 Immediate Action TLV

The Immediate Action TLV is a BER-TLV data object that allows the Remote Management Application to issue a proactive command during the execution or that allows to abort the execution if a proactive session is ongoing. It shall be formatted as shown in table 5.3 or table 5.4.

Table 5.3: Immediate Action TLV - normal format

Length in bytes	Name
1	Immediate Action tag (see annex A)
L	Length of Immediate Action = A > 1
A	Set of COMPREHENSION-TLV data objects

Table 5.4: Immediate Action TLV - referenced format

Length in bytes	Name
1	Immediate Action tag (see annex A)
1	Length of Immediate Action = 1
1	'01' to '7F': Reference to a record in EF _{RMA} '81': Proactive session indication '82': Early response other values: RFU

In case of reference to a record in EF_{RMA}, the referenced record shall contain the set of COMPREHENSION-TLV data objects preceded by a length value as defined for a BER-TLV, see ETSI TS 102 222 [9].

If present, the Immediate Action TLV coding "proactive session indication" shall be:

- The first Command TLV in the script if there is no script chaining.
- The second Command TLV in the script if there is script chaining.

In case of "proactive session indication", execution of the remaining script shall be suspended if a proactive session is ongoing. Script processing shall be resumed after the end of the proactive session. If the UICC cannot suspend the script execution, e.g. because there are not enough internal resources available, the UICC shall terminate the processing of the script and return a "suspension error" in the response data.

If no "proactive session indication" is present as first Command TLV and another proactive session is ongoing, proactive commands in the script shall be silently ignored.

In case of "early response", the response to the sending entity shall be sent before processing the rest of the command TLVs. The number of executed commands TLV objects shall include all objects up to the immediate action TLV encoding the "early response". No other response data shall be sent after the response sent due to the early response action TLV.

NOTE: This is useful in case of some refresh modes, where the UICC might not be able to send a response after the refresh is performed by the terminal.

Proactive commands as defined in table 5.5 are allowed as Immediate Action. The behaviour of the card for other commands is undefined.

Table 5.5: Allowed proactive commands for Immediate Action

DISPLAY TEXT
PLAY TONE
REFRESH

5.2.1.3 Error Action TLV

The Error Action TLV is a BER-TLV data object that allows the Remote Management Application to issue a proactive command in case of error in the execution. It shall be formatted as shown in tables 5.6, 5.7 or 5.8.

The Error Action tag is defined in annex A.

Table 5.6: Error Action TLV - normal format

Length in bytes	Name
1	Error Action tag
L	Length of Error Action = A > 1
A	Set of COMPREHENSION-TLV data objects

Table 5.7: Error Action TLV - referenced format

Length in bytes	Name
1	Error Action tag
1	Length of Error Action = 1
1	'01' to '7F': Reference to a record in EF _{RMA} other values: RFU

Table 5.8: Error Action TLV - no action

Length in bytes	Name
1	Error Action tag
1	Length of Error Action = 0

In case of referenced format, the referenced record in EF_{RMA} shall contain the set of COMPREHENSION-TLV data objects preceded by a length value as defined for a BER-TLV, see ETSI TS 123 048 [10].

Proactive commands as defined in table 5.9 are allowed as Error Action. The behaviour of the card for other commands is undefined.

Table 5.9: Allowed proactive commands for Error Action

DISPLAY TEXT
PLAY TONE

If an error is encountered when processing a C-APDU, error actions shall be performed as follows:

- If there is an Error Action TLV between the start of the script and the C-APDU resulting in an error, the action defined in the last Error Action TLVs shall be performed. If this last Error Action TLV has zero length, no action shall be performed.
- If there is no Error Action TLV between the start of the script and the C-APDU resulting in an error, no action shall be performed.

5.2.1.4 Script Chaining TLV

The optional Script Chaining TLV is a BER-TLV data object and shall be coded as shown in table 5.9a.

Table 5.9a: Script Chaining TLV

Length in bytes	Name
1	Script Chaining tag
1	Script Chaining Length = 1
1	Script Chaining Value

The Script Chaining tag is defined in annex A.

If present, the Script Chaining TLV shall be present only once and shall be the first Command TLV in the Command Script. It may only be present for Remote File Management or Remote Application Management. If it is received by any other application standardized in the present document, the error "Script Chaining not supported by this application" shall be sent back to the sending entity.

The Script Chaining Value is defined as follows:

- '01': first script - delete chaining information upon card reset - valid for RFM and RAM.
- '11': first script - keep chaining information across card reset - valid for RFM only.
- '02': subsequent script - subsequent script(s) will follow.
- '03': subsequent script - last script.

Whether or not chaining information is kept across card reset(s) is defined in the first script for the whole chain.

With script chaining, a command session is extended beyond the scope of one command scripting TLV; the session context is kept until the last script.

5.2.2 Expanded Remote response structure

The additional response application data which may be sent by a Remote Management application is a BER-TLV data object.

In case no Script Chaining is present in the command list or processing of the Script Chaining produces no error, it shall be formatted according to table 5.10 or table 5.10a.

Two variants exist for the expanded remote response structure:

- The Response Scripting template is a BER-TLV data object as defined in ETSI TS 101 220 [5], i.e. it uses definite length coding; see table 5.2. It shall be used if the command scripting template used definite length coding.
- The Response Scripting template is a BER-TLV data object which uses indefinite length coding as defined in ISO/IEC 8825-1 [21]; see table 5.2a. It shall be used if the command scripting template used indefinite length coding.

The tags of these TLVs are defined in annex A.

Table 5.10: Expanded Format of Remote Management application additional response data - definite length coding

Length in bytes	Name
1	Response Scripting template tag for definite length coding
L	Length of Response Scripting template = X+A+B...C
X	Number of executed Command TLV objects
A	R-APDU of first executed case 2 / case 4 C-APDU in the script
B	R-APDU of second executed case 2 / case 4 C-APDU in the script
	...
C	R-APDU of last executed C-APDU (case 1, 2, 3 or 4) in the script or Bad format TLV
NOTE: If the last executed C-APDU is a case 2 or case 4 command, its corresponding R-APDU TLV shall only be present once in the Response Scripting template.	

Table 5.10a: Expanded Format of Remote Management application additional response data - indefinite length coding

Length in bytes	Name
1	Response Scripting template tag for indefinite length coding
1	Indicator for indefinite length coding (value '80')
A	R-APDU of first executed C-APDU in the script
B	R-APDU of second executed C-APDU in the script
	...
C	R-APDU of last executed C-APDU in the script or Bad format TLV
2	End of content indicator (value '00 00')

The Number of executed command TLV objects is a BER-TLV data object and shall be coded as shown in table 5.11.

Table 5.11: Number of executed command TLV objects

Length in bytes	Description
1	Number of executed command TLV objects tag
1	Length=Y
Y	Number of executed command TLV objects value

The Number of executed command TLV objects tag is defined in annex A. The Number of executed command TLV objects value corresponds to the number of command TLV objects executed within the command script and is coded as an integer according to ISO/IEC 8825-1 [21].

The structure of each R-APDU shall be a TLV structure coded according to the R-APDU COMPREHENSION-TLV data object coding defined in ETSI TS 102 223 [3]. The restriction on the length of the R-APDU mentioned in the note in ETSI TS 102 223 [3] shall not apply. For Le='00', the length of the R-APDU may be coded on more than two bytes.

A Remote Management application response string may contain a single or several R-APDU TLVs.

In case of an unknown Tag, or TLV with a wrong format (e.g. length of Command TLV exceeding end of Command Scripting template or length of C-APDU TLV < 4) is encountered while processing the command script, a Bad format TLV shall be put into the response data and processing of the command script shall be aborted at that point.

The Number of executed C-APDUs shall take into account the incorrectly formatted TLV.

The Bad format TLV is a BER-TLV data object and shall be coded as shown in table 5.12.

Table 5.12: Bad format TLV

Length in bytes	Description
1	Bad format TLV tag
1	Length
1	Error type

Error type Coding:

- '01': Unknown Tag found.
- '02': Wrong length found.
- '03': Length not found.
- other values: RFU.

If "proactive session indication" is present in the script and a proactive session is ongoing and the UICC is unable to suspend script processing, the additional response application data shall be formatted according to table 5.13 or table 5.13a and table 5.14 and indicate "suspension error".

Table 5.13: Expanded Format of Remote Management application additional response data in case of Immediate Action error - definite length coding

Length in bytes	Name
1	Response Scripting template tag for definite length coding
L	Length of Response Scripting template = X+A
X	Number of executed command TLV objects (value is 1)
A	Immediate Action Response

Table 5.13a: Expanded Format of Remote Management application additional response data in case of Immediate Action error - indefinite length coding

Length in bytes	Name
1	Response Scripting template tag for indefinite length coding
1	Indicator for indefinite length coding (value '80')
A	Immediate Action Response
2	End of content indicator (value '00 00')

The Immediate Action Response is an Immediate Action Response TLV which is a BER-TLV data object coded as shown in table 5.14.

Table 5.14: Immediate Action Response TLV

Length in bytes	Description
1	Immediate Action Response tag
1	Length=X
X	Immediate Action Response Value

The Immediate Action Response tag is defined in annex A.

The Immediate Action Response Value is defined as follows:

- '01': Suspension error.

In case a Script Chaining TLV indicating "subsequent script - ..." is present in the list, the following situations shall be considered as chaining errors:

- The previous script did not contain a Script Chaining TLV indicating "first script - ..." or "subsequent script - subsequent script(s) will follow".
- The first script of the chain indicating "first script - delete chaining information upon card reset" was processed in an earlier card session.

In case of chaining errors, the additional response application data shall be formatted according to table 5.15 or table 5.15a.

Table 5.15: Expanded Format of Remote Management application additional response data in case of Script Chaining error - definite length coding

Length in bytes	Name
1	Response Scripting template tag for definite length coding
L2	Length of Response Scripting template = X+A
X	Number of executed Command TLV objects
A	Script Chaining Response

Table 5.15a: Expanded Format of Remote Management application additional response data in case of Script Chaining error - indefinite length coding

Length in bytes	Name
1	Response Scripting template tag for indefinite length coding
1	Indicator for indefinite length coding (value '80')
A	Script Chaining Response
2	End of content indicator (value '00 00')

The Script Chaining Response TLV is a BER-TLV data object and shall be coded as shown in table 5.16.

Table 5.16: Script Chaining Response TLV

Length in bytes	Description
1	Script Chaining Response tag
1	Length=X
X	Script Chaining Result Value

The Script Chaining Response tag is defined in annex A. The Script Chaining Result Value is defined as follows:

- '01': No previous script.
- '02': Script Chaining not supported by this application.

- '03': Unable to process script chaining (e.g. no resources to store chaining context).

5.3 Automatic application data format detection

If a TAR is configured for multiple data formats, the following automatic application data format detection shall apply:

- If b2b1 of the first data byte of the application data are 00, the format of the application data shall be the compact remote application data format.
- Otherwise, the first data byte of the application data shall indicate the format of the data packet.

NOTE: b2b1 of the CLA byte, which is the first byte in compact format, indicate the logical channel. As logical channels are not used in remote management, these can be used to indicate other data formats. With the tag value chosen for the expanded format, this allows for co-existence of both formats even if the same TAR is used.

6 Security parameters assigned to applications

6.1 Minimum Security Level (MSL)

The Minimum Security Level (MSL), which can be set individually for each application in its INSTALL [for install] command, is used to specify the minimum level of security to be applied to Secured Packets sent to any Receiving Application. The Receiving Entity shall check the Minimum Security Level, set for the Receiving Application, before processing the security of the Command Packet. If the check fails, the Receiving Entity shall reject the messages and response processing shall be done as defined in ETSI TS 102 225 [1]. If a Response Packet is sent, the Response Status Code (see ETSI TS 102 225 [1]) shall be set to "Insufficient Security Level".

NOTE: According to UICC Configuration [16], if the Receiving Application is a Security Domain which has no own secure channel key set, then the security will be processed by the closest ascendant Security Domain (= Receiving Entity) that has a suitable secure channel key set.

A Minimum Security Level as described in clause 8.2.1.3.2.4 shall be assigned to each Remote Management application (RFM/RAM).

6.2 Access domain

The Access Domain is a parameter used to define the access rights granted to an Application allowing it to perform operations on UICC files specified in ETSI TS 102 221 [2]. Access Conditions of UICC Files shall be coded as defined in ETSI TS 102 221 [2].

The access rights granted to an application by its Access Domain shall be independent from the access rights granted at the UICC/Terminal interface.

NOTE: This implies in particular that the status of a secret code (e.g. disabled PIN1, blocked PIN2, etc.) at the UICC/Terminal interface does not affect the access rights granted to an application.

An Access Domain as described in clause 8.2.1.3.2.5 shall be assigned to each Remote File Management Application.

7 Remote File Management (RFM)

7.0 RFM basic principles

The concept of embedding APDUs in a command packet and the Additional Response data in a response packet shall be as defined in the previous clauses describing the Compact and expanded Remote Application data format.

Unless a TAR is used that is configured for automatic application data format detection, the Compact and expanded Remote Application data formats shall be distinguished by different TAR values.

For the Expanded Remote Application data format, it is possible to chain two or more scripts using Script Chaining TLVs.

If a Script Chaining TLV indicating "first script - ..." or "subsequent script - subsequent script(s) will follow" is processed successfully, the file context (current directory, current file, current tag pointer, etc.) and the PIN verification status at the end of the script shall be remembered until the next script is processed by the Remote File Management application. If the next script received successfully contains a Script Chaining TLV indicating "subsequent script - ...", the remembered file context and PIN verification status shall be restored. Else the default context shall be used.

If a non-shareable file is selected by the remembered file context, the mechanisms defined in ETSI TS 102 221 [2] limiting the access to non-shareable files shall apply.

NOTE: It is up to the sending entity to guarantee that a sequence of scripts, each relying on the context of the previous one, is processed in the correct sequence by the UICC. This can be achieved by using a reliable transport mechanism, by waiting for a positive response of one script before sending the next, or by using appropriate settings in the security layer ("process only if counter value is one higher than previous value").

7.1 Commands

The standardized commands are listed in table 7.1. The commands are as defined in ETSI TS 102 221 [2] and ETSI TS 102 222 [9].

Table 7.1: Remote File Management commands

Operational command	Support M/O/C
SELECT (see below)	M
UPDATE BINARY	M
UPDATE RECORD	M
SEARCH RECORD	M
INCREASE	M
VERIFY PIN	O
CHANGE PIN	O
DISABLE PIN	O
ENABLE PIN	O
UNBLOCK PIN	O
DEACTIVATE FILE	M
ACTIVATE FILE	M
READ BINARY	M
READ RECORD	M
CREATE FILE	M
DELETE FILE	M
RESIZE FILE	M
SET DATA	C
RETRIEVE DATA	C

The SELECT command shall not include the selection by DF name corresponding to P1='04' in the Command Parameters of SELECT (see ETSI TS 102 221 [2]).

The support of the commands VERIFY PIN, CHANGE PIN, DISABLE PIN, ENABLE PIN and UNBLOCK PIN is optional for the RFM Application.

The support of the commands SET DATA and RETRIEVE DATA by the RFM Application is conditional on the support of these commands by the UICC platform.

The Response Data shall be placed in the Additional Response Data element of the Response Packet:

- If P3/Le = '00' in the READ RECORD command, then the UICC shall send back the whole record data.

- If P3/Le = '00' in the READ BINARY command, then the UICC shall send back all data until the end of the file, according to clause 5.1.
- If P3/Le = '00' in the RETRIEVE DATA command, then the UICC shall send back all data until the end of the data object from the current BER-TLV structure EF.

7.2 UICC Shared File System Remote File Management

A UICC Shared File System Remote File Management application shall have access only to the MF and all DFs and EFs that are located under the MF.

NOTE: ADFs are not considered to be files located under the MF.

Unless Script Chaining is used, the MF shall be implicitly selected and be the current directory at the beginning of a "Command session".

No ADF shall be accessed by the UICC Shared File System Remote File Management application.

All commands defined in clause 7.1 shall apply.

The TAR value of the UICC Shared File System Remote File Management application is defined in ETSI TS 101 220 [5].

7.3 ADF Remote File Management

An ADF Remote File Management application shall have access to the DFs and EFs located under the ADF.

Unless Script Chaining is used, the ADF shall be implicitly selected and be the current directory at the beginning of a "Command session".

The UICC Shared File System, i.e. the MF and all DFs and EFs that are located under the MF, may also be accessed, depending on the access rights granted to the ADF Remote File Management application.

NOTE: ADFs are not considered to be files located under the MF.

All commands defined in clause 7.1 shall apply.

The TAR of an ADF RFM application shall be linked to the AID of the application to which the ADF belongs.

The TAR value of an ADF Remote File Management application is defined in ETSI TS 101 220 [5].

7.4 RFM implementation over HTTPS

When using remote APDUs to perform RFM over HTTPS, the header values defined in ETSI TS 102 225 [1] apply. The RFM/HTTP communication flow is illustrated in annex B.

7.5 RFM implementation over CoAP/DTLS

When using remote APDUs to perform RFM over CoAP/DTLS, the header values defined in ETSI TS 102 225 [1] apply. The RFM over CoAP/DTLS communication flow is illustrated in annex D.

8 Remote Application Management (RAM)

8.0 RAM basic principles

Remote application management capability is provided by a GlobalPlatform Security Domain. The exact feature set of the Security Domain is described in the table "Authorized GlobalPlatform Commands per Card Life Cycle State" of GlobalPlatform Card Specification [4].

NOTE 1: According to this table a Security Domain performing a LOAD, INSTALL or DELETE command has DM or AM privilege. For other activities (e.g. information retrieval or key personalization) no privilege besides that of a Security Domain itself is needed.

NOTE 2: The description of the applicability of the rules for RAM Application in previous versions of the present document was not precise with regard to Security Domains without DM or AM privilege. Therefore UICCs compliant to previous versions of the present document may exist which are not fully interoperable with regard to the behaviour of Security Domains without AM or DM privilege.

All GlobalPlatform features and functionality that are described in the present clause, as well as the assignment of GlobalPlatform privileges shall comply with GlobalPlatform Card Specification [4] as detailed in the UICC Configuration [16].

A RAM Application shall support all features and functionality described in the present clause unless they are specifically described as optional.

The support of the APIs related to GlobalPlatform Card Specification [4], e.g. Java Card™ API [25], Multos™, API is optional. If implemented, it shall follow the specification in the UICC Configuration [16], especially concerning the Secure Channel Interface usage.

The TAR value allocated for the Issuer Security Domain is defined in ETSI TS 101 220 [5].

The concept of embedding APDUs in a command packet and the Additional Response data in a response packet shall be as defined in the previous clauses describing the Compact and expanded Remote Application data format.

Unless a TAR is used that is configured for automatic application data format detection, the Compact and expanded Remote Application data formats shall be distinguished by different TAR values.

The Minimum Security Level of a RAM Application shall require at least integrity using CC or DS. It applies to all data formatted as secured data according to clause 4 of the present document and including all commands listed in table 8.1.

The card shall support the AES algorithm for cryptographic computations.

Single DES and triple DES are deprecated.

NOTE 3: Single DES and triple DES were supported in previous releases of the present document.

8.1 Remote application management application behaviour

Remote Load File loading, Application installation, Load File removal, Application removal, Application locking/unlocking, Application information retrieval shall be compliant to GlobalPlatform Card Specification [4] as detailed in the UICC Configuration [16].

Support of the application personalization described in GlobalPlatform Card Specification [4] is optional.

As a RAM Application is a Receiving Application per clause 4, application selection (SELECT command) and command dispatching as described in GlobalPlatform Card Specification [4] do not apply to Remote Application Management.

8.2 Command coding and description

8.2.0 Basic rules

Commands and responses shall be coded according to GlobalPlatform Card Specification [4] as detailed in the UICC Configuration [16] unless otherwise specified in the present document.

Secure messaging shall be based on ETSI TS 102 225 [1]. Except if additional application provider security as defined in clause 10.2 is applied, the secure messaging as defined in GlobalPlatform Card Specification [4] shall not apply to RAM APDU commands and responses (e.g. MAC shall not be present in the command data field). In addition the class byte shall indicate that an APDU command includes no secure messaging.

The logical channel number indicated in the class byte shall be zero.

Command status words placed in the Additional Response Data element of the Response Packet shall be coded according to the GlobalPlatform Card Specification [4] as detailed in the UICC Configuration [16].

8.2.1 Commands

8.2.1.0 Application management commands overview

The standardized commands are listed in table 8.1.

Table 8.1: Application management commands

Operational command
DELETE
SET STATUS
INSTALL
LOAD
PUT KEY
GET STATUS
GET DATA as case 2 command GET DATA as case 4 command (for Menu parameters)
STORE DATA

The Response Data shall be placed in the Additional Response Data element of the Response Packet.

Script chaining may be used for confidential application management as specified in clause 10 or to chain a sequence of STORE DATA commands. It has no effect for other commands. However, whenever it is present for RAM, it shall be processed as defined in the present document.

When using the Compact Remote Application data format and if an application session is saved beyond a command session as defined below, this session context shall be deleted upon card reset.

8.2.1.1 DELETE

The removal of Applications, of Executable Load Files, and of Executable Load Files and its related Applications shall be supported.

8.2.1.2 SET STATUS

The management of Applications, Issuer Security Domain and Security Domains Life Cycle States shall be supported.

8.2.1.3 INSTALL

8.2.1.3.0 Basic requirements for INSTALL command

INSTALL [for load], INSTALL [for install] and INSTALL [for make selectable] commands shall be supported.

INSTALL [for personalization] and Install [for extradition] command described in GlobalPlatform Card Specification [4] are optional. A UICC supporting confidential application management as specified in clause 10 shall support INSTALL [for personalization]. If implemented, both commands shall follow the specification in the UICC Configuration [16].

In addition the support of the combined [for install and make selectable] within the same INSTALL command is mandatory.

When using the Compact Remote Application data format, the context established by INSTALL [for load] shall be saved across command sessions until the last LOAD command and the context established by INSTALL [for personalization] (if supported) shall be saved across command sessions until the STORE DATA command containing the last block.

8.2.1.3.1 INSTALL [for load]

Support and presence of the Load File Data Block Hash according to GlobalPlatform Card Specification [4] shall be as specified in the UICC Configuration [16].

NOTE: The exact generation of the DAP was not defined in pre-Release 6 predecessors of the present document. Inter-operability with pre-Release 6 implementations should be handled with care.

If present, the Load Parameter Field of the INSTALL [for load] command shall be coded according to GlobalPlatform Card Specification [4].

If the System Specific parameters "Non volatile code space limit" (Tag 'C6'), "Volatile data space limit" (Tag 'C7') and "Non volatile data space limit" (Tag 'C8') are present, the UICC shall be able to handle them.

8.2.1.3.2 INSTALL [for install]

If present, the Install Parameter Field of the INSTALL [for install] command shall be coded according to GlobalPlatform Card Specification [4].

If the System Specific parameters "Volatile data space limit" (Tag 'C7') and "Non volatile data space limit" (Tag 'C8') are present, the UICC shall be able to handle them.

The application instance shall be registered with the instance AID present in the INSTALL [for install] command.

In case of Java Card™ applications, the application may invoke the register(bArray, bOffset, bLength) or the register() method:

- If the register (bArray, bOffset, bLength) is invoked, the AID passed in the parameters shall be the instance AID provided in the install method buffer.
- If the register() method is invoked the instance AID present in the INSTALL [for install] command and the AID within the Load File, as specified in GlobalPlatform Card Specification [4], should be the same.

The "UICC System Specific Parameters" TLV object (Tag 'EA', as defined below) is included in the Install Parameter Field and shall be coded as follows:

Presence	Length	Name	Value
Optional	1	Tag of UICC System Specific Parameters constructed field.	'EA'
	1 to 3	Length of UICC System Specific Parameters constructed field as specified in GlobalPlatform Card Specification [4] for TLV data objects. Coded as defined in ETSI TS 101 220 [5] for a BER-TLV data object.	
	0 to n	UICC System Specific Parameters constructed value field.	

8.2.1.3.2.1 Coding of the SIM File Access and Toolkit Application Specific Parameters

The "SIM File Access and Toolkit Application Specific Parameters" TLV object (Tag 'CA', as defined below) is included in the "System Specific Parameters" (Tag 'EF') and shall be coded as follows:

Presence	Length	Name	Value
Optional	1	Tag of SIM file access and toolkit application specific parameters field.	'CA'
	1 to 3	Length of SIM file access and toolkit application specific parameters field. Coded as defined in ETSI TS 101 220 [5] for a BER-TLV data object.	
	6 to n	SIM file access and toolkit Application specific Parameters.	

The SIM file access and toolkit application specific parameters field is used to specify the terminal and UICC resources the application instance can use. These resources include the timers, the Bearer Independent protocol channels, menu items for the Set Up Menu, the Minimum Security Level and the TAR Value(s) field. The Network Operator or Service Provider can also define the menu position and the menu identifier of the menus activating the application.

The SIM file access and toolkit parameters are mandatory for applications using the *sim.toolkit.ToolkitInterface* or *sim.access.SIMView* interface as defined in ETSI TS 143 019 [12]. The Access Domain is applicable to applications using the *sim.access.SIMView* interface as defined in ETSI TS 143 019 [12].

Length	Name	Value
1	Length of Access Domain field	
1 to p	Access Domain	
1	Priority level of the Toolkit application instance	
1	Maximum number of timers allowed for this application instance	
1	Maximum text length for a menu entry	
1	Maximum number of menu entries allowed for this application instance	= m
1	Position of the first menu entry	\
1	Identifier of the first menu entry ('00' means do not care)	
	= 2 × m bytes
1	Position of the last menu entry	
1	Identifier of the last menu entry ('00' means do not care)	/
1	Maximum number of channels for this application instance	
1	Length of Minimum Security Level field	
0 to q	Minimum Security Level (MSL)	
1	Length of TAR Value(s) field	
3 × y	TAR Value(s) of the Toolkit Application instance	

See the following clauses for the description of the parameters fields.

8.2.1.3.2.2 Coding of the UICC System Specific Parameters

If the SIM file access and toolkit parameters TLV object (tag 'CA') is present and the UICC System Specific Parameters TLV object (tag 'EA') is present, the card shall return the Status Word '6A80', incorrect parameters in data field, to the INSTALL [for install] command.

The UICC System Specific Parameters constructed value field of the INSTALL [for Install] command shall be coded as follows:

Presence	Length	Name	Value
Optional	1	Tag of UICC Toolkit Application specific parameters field	'80'
	1	Length of UICC Toolkit Application specific parameters field	
	N	UICC Toolkit Application specific parameters	
Optional	1	Tag of UICC Toolkit parameters DAP	'C3'
	1	Length of UICC Toolkit parameters DAP	
	N	UICC Toolkit parameters DAP	
Optional	1	Tag of UICC Access Application specific parameters field	'81'
	1	Length of UICC Access Application specific parameters field	
	N	UICC Access Application specific parameters	
Optional	1	Tag of UICC Administrative Access Application specific parameters field	'82'
	1	Length of UICC Administrative Access Application specific parameters field	
	N	UICC Administrative Access Application specific parameters	

Access parameters for the same ADF may be present in both the UICC Access Application specific parameters field and the UICC Administrative Access Application specific parameters field. The same applies for the UICC file system.

8.2.1.3.2.2.1 UICC Toolkit Application specific parameters field

The UICC toolkit application specific parameters field is used to specify the terminal and UICC resources the application instance can use. These resources include the timers, the Bearer Independent Protocol channels, the services for local bearers, menu items for the Set Up Menu, the Minimum Security Level and the TAR Value(s) field. The Network Operator or Service Provider can also define the menu position and the menu identifier of the menus activating the application.

The UICC toolkit parameters are mandatory for applications using the *uicc.toolkit.ToolkitInterface* defined in ETSI TS 102 241 [6] and for Applets extending the *SCWSExtension* interface as defined in ETSI TS 102 588 [17] that make use of the *ProactiveHandler* and the *ProactiveResponseHandler*. None of the toolkit resources will be accessible if the UICC toolkit parameters are missing. These parameters shall be coded as follows:

Length	Name	Value
1	Priority level of the Toolkit application instance	
1	Maximum number of timers allowed for this application instance	
1	Maximum text length for a menu entry	
1	Maximum number of menu entries allowed for this application instance	= m
1	Position of the first menu entry	\
1	Identifier of the first menu entry ('00' means do not care)	
	= 2 × m bytes
1	Position of the last menu entry	
1	Identifier of the last menu entry ('00' means do not care)	/
1	Maximum number of channels for this application instance	
1	Length of Minimum Security Level field	
0-q	Minimum Security Level (MSL)	
1	Length of TAR Value(s) field	
3 × y	TAR Value(s) of the Toolkit Application instance	
1	Maximum number of services for this application instance	

Any additional parameters shall be ignored by the card.

8.2.1.3.2.2.2 UICC Access Application specific parameters field

The UICC access application specific parameters field is used to specify the access rights. The application instance is granted access rights to files only according to these UICC access parameters.

The UICC access parameters are applicable to applications using the *uicc.access.FileView* defined in ETSI TS 102 241 [6]. These parameters shall be coded as follows:

Presence	Name	Length
○	Length of UICC file system AID	1
	Empty UICC file system AID	0
	Length of Access Domain for UICC file system	1
	Access Domain for UICC file system	n
	Length of Access Domain DAP	1
	Access Domain DAP	0 or n
○	Length of ADF #1 AID	1
	ADF #1 AID	5 to 16
	Length of Access Domain for ADF #1	1
	Access Domain for ADF #1	N
	Length of Access Domain DAP #1	1
	Access Domain DAP #1	0 or n
...
...
○	Length of ADF #n AID	1
	ADF #n AID	5 to 16
	Length of Access Domain for ADF #n	1
	Access Domain for ADF #n	n
	Length of Access Domain DAP #n	1
	Access Domain DAP #n	0 or n

See the following clauses for the description of the parameters fields.

8.2.1.3.2.2.3 UICC Toolkit Parameters DAP

The UICC toolkit parameters DAP is an optional signature. The card issuer's security policy may require the presence of this DAP.

The input data used to compute this DAP is the concatenation of the following data:

Description	Length
Length of instance AID	1
Instance AID	5 to 16
Length of UICC Toolkit parameters	1
UICC Toolkit parameters	n

The key used to compute this DAP is: Key identifier '02' of Key Version number '11' in the Issuer Security Domain.

Depending on the key type:

- If padding is required by the algorithm, the data is appended by '80' and filled up with zero or more '00'.
- AES [13] shall be used in CMAC mode [15]. The length of the MAC shall be associated with the key.

8.2.1.3.2.2.4 UICC Administrative Access Application specific parameters field

The UICC Administrative access application specific parameters field is used to specify the access rights. The application instance is granted access rights to administrate files only according to these UICC Administrative access parameters.

The UICC Administrative access parameters are applicable to applications using the *uicc.access.fileadministration.AdminFileView* defined in ETSI TS 102 241 [6]. These parameters shall be coded as defined in clause 8.2.1.3.2.2.2.

8.2.1.3.2.3 Description of Toolkit Application Specific Parameters

If the maximum number of timers required is greater than '08' (maximum numbers of timers specified in ETSI TS 102 223 [3]), the card shall return the Status Word '6A80', incorrect parameters in data field, to the INSTALL [for install] command.

If the maximum number of channels required is greater than '07' (maximum numbers of channels specified in ETSI TS 102 223 [3]), the card shall return the Status Word '6A80', incorrect parameters in data field, to the INSTALL [for install] command.

If the maximum number of services requested is greater than '08' (maximum numbers of services specified in ETSI TS 102 223 [3]), the card shall return the Status Word '6A80', incorrect parameters in data field, to the INSTALL [for install] command.

The mechanism to manage the position of the Menu Entries is defined in ETSI TS 102 241 [6].

A part of the item identifier shall be under the control of the card system and the other part under the control of the card issuer. Item identifiers are split in two ranges:

- [1...127] under control of the card issuer.
- [128...255] under the control of the toolkit framework.

If the requested item identifier is already allocated, or in the range [128...255], then the card shall reject the INSTALL command. If the requested item identifier is '00', the card shall take the first free value in the range [128...255].

8.2.1.3.2.4 Coding of the Minimum Security Level (MSL)

If the length of the Minimum Security Level (MSL) field is zero, no minimum security level check shall be performed by the Receiving Entity.

If the length of the Minimum Security Level (MSL) field is greater than zero, the Minimum Security Level (MSL) field shall be coded according to the following table:

Length	Name
1	MSL Parameter
q to 1	MSL Data

The MSL Data coding and length is defined for each MSL Parameter.

8.2.1.3.2.4.1 MSL Parameter

The possible values for the MSL Parameter are:

Value	Name	Support	MSL Data length
'00'	RFU	RFU	N/A
'01'	Minimum SPI1	Optional	1
'02' to '7F'	RFU	RFU	N/A
'80' to 'FE'	Reserved for Proprietary Mechanisms	Optional	N/A
'FF'	RFU	RFU	N/A

8.2.1.3.2.4.2 Minimum SPI1

The Minimum Security Level Data (MSLD) for the Minimum SPI1 MSL parameter shall use the same coding as the first octet of the SPI of a command packet (see clause 5.1.1 of ETSI TS 102 225 [1]).

The first octet of the SPI field in the incoming message Command Packet (SPI1) shall be checked against the Minimum Security Level Data (MSLD) byte by the receiving entity according to the following rules:

- if SPI1.b2b1 is equal to or greater than MSLD.b2b1;
- if SPI1.b3 is equal to or greater than MSLD.b3; and

- if SPI1.b5b4 is equal to or greater than MSLD.b5b4;

then the Message Security Level is sufficient and the check is successful, otherwise the check is failed.

8.2.1.3.2.5 Coding of the Access domain

The Access Domain field is formatted as follows:

Length	Name
1	Access Domain Parameter (ADP)
p to 1	Access Domain Data (ADD)

The Access Domain Data (ADD) coding and length is defined for each Access Domain Parameter (ADP).

8.2.1.3.2.5.1 Access Domain Parameter

This parameter indicates the mechanism used to control the application instance access to the File System.

Value	Name	Support	ADD length
'00'	Full access to the File System	Mandatory	0
'01'	Reserved (for APDU access mechanism)	-	-
'02'	UICC access mechanism	Mandatory	3
'03' to '7F'	RFU	RFU	RFU
'80' to 'FE'	Proprietary mechanism	-	-
'FF'	No access to the File System	Mandatory	0

The access rights granted to an application and defined in the access domain parameter shall be independent from the access rights granted at the UICC/Terminal interface.

NOTE: This implies in particular that the status of a secret code (e.g. disabled PIN1, blocked PIN2, etc.) at the UICC/Terminal interface does not affect the access rights granted to an application.

If an application with Access Domain Parameter (ADP) 'FF' (i.e. No Access to the File System) tries to access a file the framework shall throw an exception.

If an application has Access Domain Parameter (ADP) '00' (i.e. Full Access to the File System), all actions can be performed on a file except the ones with NEVER access condition.

If the Access Domain Parameter (ADP) requested is not supported, the card shall return the Status Word '6A80', incorrect parameters in data field, to the INSTALL [for install] command.

8.2.1.3.2.5.2 Access Domain Data: for UICC access mechanism

The UICC access mechanism shall be coded as follows:

Byte 1:

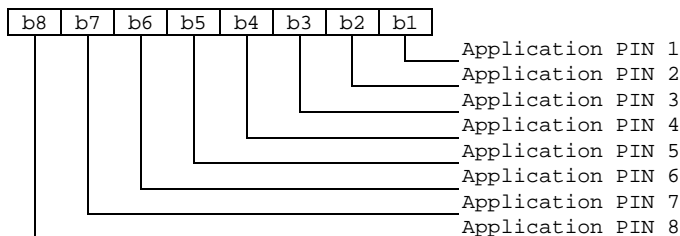

Byte 2:

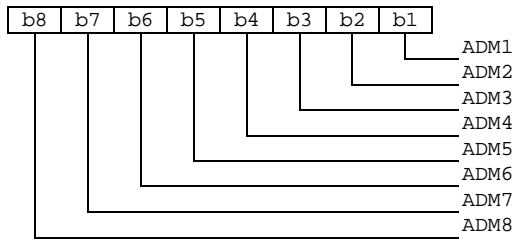

Byte 3:

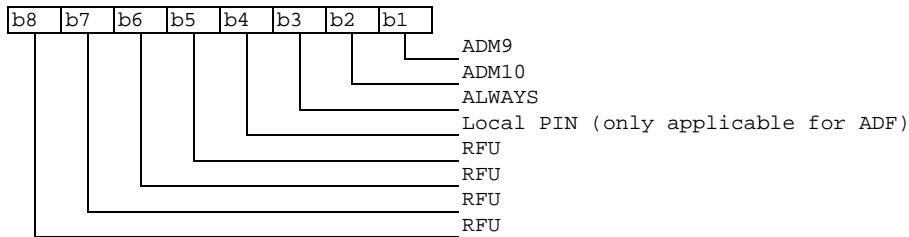

These access rights shall be checked against SE ID 01 access rules as defined in ETSI TS 102 221 [2].

8.2.1.3.2.5.3 Access Domain DAP

The Access Domain DAP is an optional signature. The security policy of the provider of the application to which the file system belongs may require the presence of this DAP.

The input data used to compute this DAP is the concatenation of the following data:

Description	Length
Length of instance AID	1
Instance AID	5 to 16
Length of File System AID	1
File System AID	0 or n
Length of Access Domain	1
Access Domain	n

In case of UICC shared File system, the Length of File System AID is 0 and the File System AID is not present.

The key used to compute this DAP is: Key identifier '02' of Key Version number '11' in the Security Domain associated to the application to which the File System belongs. In case of UICC shared file system, the associated Security Domain may be the Issuer Security Domain or another Security Domain, depending on the card issuer's security policy.

Depending on the key type:

- If padding is required by the algorithm, the data is appended by '80' and filled up with zero or more '00'.
- AES [13] shall be used in CMAC mode [15]. The length of the MAC shall be associated with the key.

8.2.1.3.2.6 Priority level of the toolkit application

The priority specifies the order of activation of an application compared to the other application registered to, the same event. If two or more applications are registered to the same event and have the same priority level, the applications are activated according to their installation date (i.e. the most recent application is activated first). The following values are defined for priority:

- '00': RFU.
- '01': Highest priority level.
- ...
- 'FF': Lowest priority level.

8.2.1.3.2.7 Coding of TAR Value(s) field

The TAR is defined and coded according to ETSI TS 101 220 [5].

It is possible to define several TAR Values at the installation of a Toolkit Application.

The TAR Value(s) field shall be coded according to the following table:

Bytes	Description	Length
1 to 3	TAR Value 1	3
4 to 6	TAR Value 2	3
...
3 × y-2 to 3 × y	TAR Value y	3

If the length of TAR Value(s) is zero, the TAR may be taken out of the AID if any.

If the length of the TAR Value(s) is greater than zero then the application instance shall be installed with the TAR Value(s) field defined above and the TAR indicated in the AID if any shall be ignored.

If a TAR Value(s) is already assigned on the card for a Toolkit Application instance or if the length of TAR Value(s) field is incorrect, the card shall return the Status Word '6A80', incorrect parameters in data field, to the INSTALL [for install] command.

8.2.1.3.2.8 Parameters for contactless applications

The support of contactless card emulation mode, reader mode and CLT activity observer is optional for a UICC. A UICC not supporting card emulation mode, reader mode or CLT activity observer shall return an error when the parameters related to the specific mode are present.

An application intended to operate in contactless card emulation mode as defined in ETSI TS 102 622 [23] shall be installed as specified in GlobalPlatform Amendment C [22].

An application intended to operate in contactless reader mode as defined in ETSI TS 102 622 [23] shall be installed with parameters given below.

If present, the "Additional Contactless Parameters" TLV object (tag 'B0') shall be included in the "System Specific Parameters" (tag 'EF'). Its value part shall be coded as follows:

Tag	Length	Value	Presence
'86'	1	Reader mode protocol data Type A	Optional
'87'	N+2	Reader mode protocol data Type B	Optional
'88'	1	CLT activity observer configuration	Optional

The presence of the TLVs "Reader mode protocol data Type" indicates the RF technology/technologies that will be active once the Application Availability State of the application as defined in GlobalPlatform Amendment C [22] changes to ACTIVATED.

To present a reader mode application to the user, user interaction parameters as specified in GlobalPlatform Amendment C [22] shall be included in the installation parameters. Applicable parameters for reader mode applications are Application Visibility and Application Family.

The TLV CLT activity observer configuration determines if the Application is allowed to register a CLTObserverListener (see ETSI TS 102 705 [28]). If this TLV is not present the Application shall not be allowed to register a CLTObserverListener. The following values of CLT activity observer configuration are defined.

b8	b7	b6	b5	b4	b3	b2	b1	Meaning
-	-	-	-	-	-	-	0	Application is not allowed to register a CLTObserverListener
					-	-	1	Application is allowed to register a CLTObserverListener
X	X	X	X	X	X	X	-	RFU

8.2.1.3.2.8.1 Reader mode protocol data Type A

The value part of the Reader mode protocol data Type A has the following coding:

Parameter	Value	Length
DATARATE_MAX	Maximum data rate supported as defined in ETSI TS 102 622 [23]	1

8.2.1.3.2.8.2 Reader mode protocol data Type B

The value part of the Reader mode protocol data Type B has the following coding:

Parameter	Value	Length
AFI	Application family identifier as defined in ETSI TS 102 622 [23]	1
HIGHER_LAYER_DATA_LENGTH	Length of HIGHER_LAYER_DATA	1
HIGHER_LAYER_DATA	Higher layer data as defined in ETSI TS 102 622 [23]	N

8.2.1.4 LOAD

A card supporting DAP verification shall support the AES Scheme for Load File Data Block Signature computation according to GlobalPlatform Card Specification [4].

NOTE: DES schemes were supported in previous releases of the present document for Load File Data Block Signature computation according to GlobalPlatform Card Specification [4] and are deprecated.

When using the Compact Remote Application data format, the context established by INSTALL [for load] shall be saved across command sessions for the whole sequence until the last LOAD command.

8.2.1.5 PUT KEY

8.2.1.5.0 Generic rules for PUT KEY command

Key version number and key identifiers of KIC, KID and DEK shall be defined according to ETSI TS 102 225 [1].

The key used for ciphering the key values (e.g. KIC, KID or DEK) of the PUT KEY command is the key with identifier 3 (i.e. DEK). It is a static key.

When replacing or adding key(s) within the same key set, or when updating the key version number of a key set, the encrypting key to be used is the DEK of the same key version number as the changed key(s).

When creating keys or key set(s) or when replacing keys that do not belong to a keyset, the encrypting key to be used is the DEK of the same key version number as KIC and KID in the Command Packet containing the PUT KEY command.

The key version number of KIC and KID used to secure the Response Packet shall be the same as the key version number indicated in the Command Packet.

The transport security keys (i.e. KIC/KID) used to secure the Response Packet shall be the same as the ones of the Command Packet containing the PUT KEY command.

8.2.1.5.1 PUT KEY for AES

This clause applies if the command PUT KEY as defined in [4] is used with an AES key as encryption key (DEK).

AES is the algorithm defined in [13].

The remote entity shall cipher key values of AES keys only with an AES key of the same or greater length.

The coding of the key type for AES keys shall be '88'.

The definitions of the command PUT KEY as defined in [4] shall be extended as follows:

- The field "length of the key or key component data" defined in [4] shall be set to the length of the "key data value" defined below.

- The "key data value" defined in [4] shall be constructed as follows:

Description	Length	Value	Presence
Length of the key in bytes	1	16, 24 or 32 for AES	Mandatory
Ciphered key	16 or 32		Mandatory
Length of the MAC in bytes	1	4 or 8	Conditional

- The field "length of the key in bytes" shall be set to the length of the key contained in the field "ciphered key" (without padding).
- The field "length of the MAC" shall be present if "ciphered key" contains an AES key with key identifier '02' and key version '01' to '0F' or '11' (see clause "Coding of the KID for Cryptographic Checksum" in [1]).
- Key ciphering shall use CBC mode as defined in NIST SP 800-38A [14] with initial chaining value set to zero.
- Keys that do not fill whole blocks of the AES ciphering scheme (e.g. AES with a key length of 192 bits) shall be padded to the next block boundary. Padding octets may have any value.

8.2.1.5.2 PUT KEY for triple DES (deprecated)

Single DES and triple DES are deprecated.

NOTE: Single DES and triple DES were supported in previous releases of the present document.

8.2.1.6 GET STATUS

8.2.1.6.0 Basic rules

In addition to the mandatory values of the P1 parameter defined in GlobalPlatform Card Specification [4], combinations of the P1 parameter, i.e. setting more than one bit of b5 to b8, may be supported.

If bit 2 of the P2 parameter is set, the returned GlobalPlatform Registry Data TLV shall include an SCP Registry Data TLV (see table 8.2 for coding) which includes a Menu Parameters TLV for Issuer Security Domain, Security Domains and Applications.

Table 8.2: SCP Registry Data TLV

Presence	Length	Name	Value
Mandatory	1	Tag of SCP Registry Data constructed field.	'EA'
Mandatory	1 to 3	Length of SCP Registry Data constructed field as specified in GlobalPlatform Card Specification [4] for TLV data objects. Coded as defined in ETSI TS 101 220 [5] for a BER-TLV data object.	n
Conditional	n	Menu Parameters TLV (see table 8.2a).	see table 8.2a

Table 8.2a: Menu Parameters TLV

Presence	Length	Name	Value
Mandatory	1	Tag of Menu Parameters field.	'80'
Mandatory	1 to 3	Length of Menu Parameters field as specified in GlobalPlatform Card Specification [4] for TLV data objects. Coded as defined in ETSI TS 101 220 [5] for a BER-TLV data object.	m
Conditional	m	Menu parameters value field (see clause 8.2.1.6.1).	see table 8.3

When using the Compact Remote Application data format, the context established by GET STATUS [get first or all occurrence(s)] shall be saved across command sessions as long as more output data related to the initial GET STATUS command is available on the UICC.

8.2.1.6.1 Menu parameters

Table 8.3: Format of Menu parameters

Description	Length
First menu entry position	1
First menu entry identifier	1
First menu entry state	1
...	...
Last menu entry position	1
Last menu entry identifier	1
Last menu entry state	1

The menu entry identifiers and positions shall be the ones provided in the Menu Entries list defined in ETSI TS 102 241 [6], and shall be returned regardless of the menu entry state as well as regardless of the Application life cycle state (e.g. Selectable/Locked, etc.).

NOTE: The Menu Entry list contains the menu entries on which the method `ToolkitRegistry.initMenuEntry()` has been successfully called as defined in ETSI TS 102 241 [6].

The menu entry state is defined as follows:

- '00': menu entry is disabled.
- '01': menu entry is enabled.
- other values: RFU.

8.2.1.7 GET DATA

8.2.1.7.0 Basic rules

The value '80' for the CLA byte shall be supported. The value '00' for the CLA byte is optional.

The Issuer Security Domain shall support at least the following data object tags:

- Tag '66': Card Data.
- Tag 'E0': Key Information Template.
- If a UICC contains an Application Provider Security Domain with Delegated Management privilege, the tag values '42' and '45' shall be supported by the ISD as specified in the UICC Configuration [16].

An Application Provider Security Domain shall support at least the following data object tags:

- Tag 'E0': Key Information Template.

If confidential setup of Security Domains is supported, the Application Provider Security Domain shall support the following data object tag:

- Tag 'BF 30': Forwarded CASD Data, to retrieve certificates and CASD Management Data.

The command Get Data is extended to retrieve specific card information with tag values in P1 and P2. The following values have been defined:

- 'FF 1F': Reserved for ETSI TS 123 048 [10].
- 'FF 20': Reserved for ETSI TS 123 048 [10].
- 'FF 21': Extended Card Resources Tag, this retrieves information on the card resources used and available.
- 'FF 22' to 'FF 3F': reserved for allocation in the present document.

8.2.1.7.1 Void

8.2.1.7.2 Extended Card resources information

This data object shall be supported by the ISD. The behaviour for other SDs is undefined.

After the successful execution of the command, the GET DATA response data field shall be coded as defined in GlobalPlatform [4]. The value of the TLV coded data object referred to in reference control parameters P1 and P2 of the command message is:

Length	Description	Value
1	Number of installed application tag	'81'
1	Number of installed application length	X
X	Number of installed application	
1	Free non volatile memory tag	'82'
1	Free non volatile memory length	Y
Y	Free non volatile memory	
1	Free volatile memory tag	'83'
1	Free volatile memory length	Z
Z	Free volatile memory	

The free memory indicated shall be at least available for applications to be loaded into the ISD.

8.2.1.8 STORE DATA

A UICC supporting confidential application management as specified in clause 10 shall support the STORE DATA command as specified in the UICC Configuration [16].

Support of the STORE DATA command described in GlobalPlatform Card Specification [4] is optional, but if the Third Party Security Policy requires management of Executable Load Files access constraints, it shall be supported as specified in the following paragraphs of this clause.

When using the Compact Remote Application data format, the context established by INSTALL [for personalization] (if supported) shall be saved across command sessions until the STORE DATA command containing the last block.

The STORE DATA Command is sent to a Security Domain to specify access rights restrictions to its Executable Load Files for a specified Third Party Security Domain.

If the Forbidden Executable Load File List is present in the STORE DATA command, each Executable Load File specified in the list shall be considered as Forbidden for the indicated Third Party Security Domain. Any other Executable Load File not present in the list is allowed for the specified Third Party Security Domain.

Any subsequent loading of Load Files performed by the Third Party Security Domain shall fail if the Load File references one or more Forbidden Executable Load Files. Access rights of Executable Load Files already present on card are not affected by the command.

If a STORE DATA Command is resent to a Security Domain, specifying a Third Party Security Domain for which a Forbidden Executable Load File List has already been defined, the new Forbidden Executable Load File List replaces the previous list for this Third Party Security Domain. If the new Forbidden Executable Load File List is empty the access restrictions for this Third Party Security Domain are removed from the addressed Security Domain.

The UICC shall prevent an Executable Load File from being set as Forbidden for its associated Security Domain.

The STORE DATA command to load Forbidden Load File List shall support the chaining of multiple STORE DATA commands to transfer large amounts of data. Parameter P1 of the command shall indicate non encrypted data and BER-TLV format of the command data field.

TAG 'BE' is used to specify a Forbidden Load File List; the Third Party Security Domain AID TLV object and the Forbidden Load Files AID TLV objects are included in the Store Data Command Message to define the list of Forbidden Load Files for the Third Party Security Domain.

Presence	Length	Name	Value
Mandatory	1	Tag of Forbidden Executable Load Files AIDs constructed field	'BE'
Mandatory	1 or 2	Length of Forbidden Executable Load Files AIDs constructed field	
Mandatory		Third Party Security Domain AID TLV	
Optional		Forbidden Executable Load File #1 AID TLV	
Optional		Forbidden Executable Load File #2 AID TLV	
	
Optional		Forbidden Load File #N AID TLV	

The Third Party Security Domain AID TLV and the Forbidden Load File AID TLVs are coded as BER-TLV as defined in ETSI TS 101 220 [5] using tag '4F'.

8.3 RAM implementation over HTTPS

When using remote APDUs to perform RAM over HTTPS, the header values defined in Amendment B of the GlobalPlatform Card Specification [19] apply.

8.4 RAM implementation over CoAP/DTLS

When using remote APDUs to perform RAM over CoAP/DTLS, the CoAP Options and SCP82 Parameter TLVs defined in Amendment M of the GlobalPlatform Card Specification [29] apply. The RAM over CoAP/DTLS communication flow is illustrated in annex E.

9 Additional command for push

9.0 Introduction

The PUSH command enables an application to open a BIP channel, to establish a CAT_TP link, to open a TCP connection and/or to send an identification packet on TCP upon a remote entity request.

9.1 Push command behaviour

9.1.1 Request for open channel

The request for open channel allows a remote entity to ask an application on the UICC to open a BIP channel using the OPEN CHANNEL proactive command specified in ETSI TS 102 223 [3].

The PUSH command shall be considered completed once the terminal response to the OPEN CHANNEL proactive command has been received by the application.

9.1.2 Request for CAT_TP link establishment

The request for link establishment allows a remote entity to ask an application on the UICC to establish a CAT_TP link as defined in ETSI TS 102 127 [11].

The PUSH command shall be considered completed once the link reaches the OPEN state in CAT_TP or the link establishment is terminated due to an error condition.

9.1.3 Behaviour for responses

It is mandatory for applications that process PUSH commands to support additional response data management. The additional response data shall be coded as defined below.

When defining how to send response packets, it shall be taken into account that the processing of the PUSH command will result in proactive commands being issued.

9.1.4 Request for TCP connection

The request for a TCP connection allows a remote entity to ask an application on the UICC to establish a TCP connection as defined in ETSI TS 102 483 [20].

9.1.5 Request for Identification Packet

The request for an identification packet allows a remote entity to ask an application on the UICC to send a data packet containing identification information on a TCP connection.

9.2 Commands coding

9.2.0 Coding

Each command is coded as an APDU. Table 9.1 extends the command tables defined in clauses 7 and 8 for applications supporting BIP and/or CAT_TP.

Table 9.1: Commands

Operational command
PUSH

The PUSH command shall be coded as follows:

Code	Value
CLA	'80'
INS	'EC'
P1	'01' '80' reserved for application specific usage
P2	'01': Request for BIP channel opening '02': Request for CAT_TP link establishment '03': Request for TCP connection '04': Request for Identification Packet (see note)
Lc	Length of subsequent data field
Data	Described below
NOTE:	These values only apply for P1 = '01'.

9.2.1 Data for BIP channel opening

Command data:

Any COMPREHENSION-TLV data objects as defined for OPEN CHANNEL in ETSI TS 102 223 [3] can be present in the data field of the PUSH command. In addition, the application may define default values for one or more of these data objects. The application shall use the data objects provided by both means to construct the OPEN CHANNEL command, whereby the objects provided in the PUSH command take precedence.

For OPEN CHANNEL, related to packet data service bearer, in ETSI TS 102 223 [3] the following rules shall apply:

- The "Other address (local address)" parameter shall not be included in the command.
- "Login" parameter and "Password" parameter shall be both present or absent in the command.

If these rules are not satisfied the Push requesting BIP open channel is rejected with status word set to '6A 80'.

Response parameters/data:

If the OPEN CHANNEL command was successful (general result < '10'), the status word of the PUSH command shall be set to '90 00'.

If the OPEN CHANNEL command fails (general result ≥ '10'), the status word of the PUSH command shall be set to '6F 00' and the Result TLV of the TERMINAL RESPONSE shall be used as response data in the additional response data.

9.2.2 Data for CAT_TP link establishment**Command data:**

Description	Format from ETSI TS 102 223 [3]	M/O/C
CAT_TP Destination Port	UICC/terminal interface transport level	M
Max SDU size	Buffer size	O
Identification data	Channel data	O

For CAT_TP Destination Port the transport protocol type is insignificant and shall be set to zero. For the PUSH command, an allocable port number shall be used.

If the Max SDU size data object is present in the command data field of the PUSH command and is non null data object, and if the size is available on the UICC, then the UICC shall use the requested size.

If the Max SDU size data object is not present in the command data field of the PUSH command or is null data object, or if the UICC is not able to provide the requested size, then the UICC shall use another appropriate value.

NOTE: Max PDU length is already defined in the OPEN CHANNEL proactive command and the TERMINAL RESPONSE to it.

The identification data object present in the command data field of the PUSH command shall be used as identification data in the SYN PDU sent from the UICC. If it is of zero length, the length of the identification data in the SYN PDU shall also be zero. If identification data is not present, the ICCID shall be used as identification data in the SYN PDU. The SYN/ACK PDU sent from the remote entity shall have a null identification data field.

Response parameters/data:

If the link reaches the OPEN state in CAT_TP, the status word of the PUSH command shall be set to '90 00'.

If the CAT_TP OPEN state is not reached, the PUSH command shall be considered as failed and the status word of the PUSH command shall be set to '6F 00'. The response data in the additional response data shall be coded as follows:

- '01': SYN sent failed.
- '02': SYN/ACK not received.
- '03': ACK sent failed (first ACK).

9.2.3 Data for TCP connection opening

The PUSH command shall be sent to the Multiplexing application identified by its TAR as defined in ETSI TS 101 220 [5].

Command data:

The data field of the PUSH command shall consist of the following COMPREHENSION-TLV data objects:

Data Object from ETSI TS 102 223 [3]	M/O/C	Comment
Bearer description	M	
UICC/terminal interface transport level	M	Transport protocol type shall be set to "TCP, UICC in client mode, remote connection"
Data destination address	M	
Network Access Name	O	
Text String (User login)	O	
Text String (User password)	C	"Text String (User login)" and "Text String (User password)" shall both be present or both be absent

Response parameters:

In case of errors in the command data, the PUSH command shall be rejected with status word set to '6A 80'.

If the TCP connection opening was successful, the status word of the PUSH command shall be set to '90 00'.

If the TCP connection opening failed, the status word of the PUSH command shall be set to '6F 00'.

9.2.4 Data for sending of Identification Packet

Command data:

The data field of the PUSH command may consist of the following COMPREHENSION-TLV data objects:

Description	Format from ETSI TS 102 223 [3]	M/O/C
Identification data	Channel data	O

The identification data object present in the command data field of the PUSH command shall be used as identification data in the identification packet sent from the UICC.

If the identification data object is of zero length, the length of the identification data in the identification packet shall also be zero.

If identification data is not present, the ICCID shall be used as identification data string in the identification packet.

Response parameters:

If the identification packet was sent successfully, the status word of the PUSH command shall be set to '90 00'.

If sending of the identification packet failed, the status word of the PUSH command shall be set to '6F 00'.

9.3 Closing of the BIP channel

The BIP channel shall be closed using the CLOSE CHANNEL proactive command specified in ETSI TS 102 223 [3] once the only or last link using the channel has been closed.

10 Confidential application management

10.0 Overview and basic requirements

The features in this clause are defining confidential application management, which enables application providers to securely manage their applications on the UICC through the network of the card owner while keeping confidentiality.

Dependent on the scenario, confidential application management requires additional Security Domains:

- APSDs (Application Provider Security Domains) that provide cryptographic services for applications of the AP;
- APSDs that provide OTA capabilities;
- APSDs that provide GlobalPlatform secure channel capabilities without having OTA capabilities themselves;
- APSDs that are separated from the ISD;
- combinations of the above; and
- a CASD (Controlling Authority Security Domain), which provides security services for confidential setup of Security Domains.

The following feature is required for the APSDs:

- The ability to personalize its applications.

Dependent on the use case, APSDs can be configured in different hierarchies as specified in GlobalPlatform Card Specification [4] and the UICC Configuration [16].

The following clauses specify different features for confidential application management that may be supported by APSDs and the CASD.

The instantiation and the personalization of a Security Domain are defined in the UICC Configuration [16].

10.1 Confidential loading

If confidential loading of applications is supported, it shall be implemented as specified in the UICC Configuration [16] for the LOAD command using tag 'D4' for encrypted load files, for the key used for deciphering the load file, and for the Ciphered Load File Data Block privilege. The UICC shall support AES to decipher a load file. Single DES and triple DES for confidential loading are deprecated.

Load file ciphering shall be implemented as specified in GlobalPlatform Card Specification [4]. The ICV (Initial Chaining Vector, tag 'D3') is mandatory for AES. The requirements for the selection of the hash algorithm for the Load File Data Block Hash shall apply.

10.2 Additional application provider security

If an application provider wants to communicate confidentially with his Security Domain or an application in this Security Domain, and his Security Domain has no OTA capability, encapsulation of secured APDUs in secured packets shall be implemented as follows:

- The command string shall use the Expanded Remote Application data format.
- The command string shall be secured using SCP03. SCP03 shall be used as specified in GlobalPlatform Amendment D [26], GlobalPlatform Common Implementation Configuration [27] and GlobalPlatform UICC Configuration [16].

NOTE 1: Previous releases of the present document allowed the use of SCP02. As the use of triple DES is deprecated from Rel-18 of the present document and SCP02 is based on the use of triple DES, starting with Rel-18 of the present document, SCP02 is deprecated.

- If a script does not contain chaining information, the SCP03 secure channel session shall be terminated at the end of the command string.
- If a script contains the chaining information "first script" or "subsequent script(s) will follow", the SCP03 secure channel session shall continue with the next script until the last script, unless one of the following conditions, which shall terminate the secure channel session, applies:
 - a new first script or a script without chaining information is received but no last script of the previous secure channel session has been received;
 - card reset.
- The TAR of the command string shall represent the Security Domain that processes the SCP03 security or an application associated to this Security Domain. In the latter case, the GlobalPlatform API for the secure channel services, which is specified in GlobalPlatform Card API (org.globalplatform) [25] for Java Card™, shall be available for the application.
- The Security Domain that processes the SCP03 security shall be part of a hierarchy of Security Domains, where at least one ancestor has OTA capabilities.
- The command string shall be contained in a secure packet that is unwrapped by the closest ascendant Security Domain with OTA capabilities as specified in UICC Configuration [16].

NOTE 2: Script chaining allows the use of random card challenges in the INITIALIZE UPDATE command. This mode is one of the options defined for SCP03. As triple DES is deprecated from Rel-18 onwards of the present document, no update is done in the present document for SCP02 and pseudo-random card challenge remains the only option defined in the present document.

The support of the API related to Card Specification, Amendment A [18] is optional.

10.3 Confidential setup of Security Domains

If confidential setup of Security Domains is supported, at least one of the following scenarios shall be implemented as follows:

- Scenario #2.B (Push Model) as specified in Card Specification Amendment A [18] may be supported. If supported, RSA key sizes less than 2048 bits shall not be used.

NOTE 1: RSA key size 2048 bits and higher is subject to regulatory recommendations.

- Scenario #1 (Pull Model) using the public key scheme as specified in Card Specification Amendment A [18] may be supported. If supported, RSA key sizes less than 2048 bits shall not be used.

NOTE 2: RSA key size 2048 bits and higher is subject to regulatory recommendations.

- Scenario #3 using ECKA-EG as specified in scenario #3 in Card Specification Amendment A [18] may be supported.

The use of Scenario #1 based on triple DES or RSA1024 and Scenario #2.B based on RSA1024 which was defined in previous releases of this specification is deprecated.

The GET DATA command with "forwarded CASD Data" as specified in GlobalPlatform Card Specification Amendment A [18] defines a mechanism where data from the CASD can be retrieved in secure packets which are protected by the targeted Security Domain.

This feature shall be supported by UICCs that support at least one of the above scenarios.

10.4 Application personalization in an APSD

The mechanism specified in the UICC Configuration [16] to personalize their associated applications, using INSTALL [for personalization] and STORE DATA, shall be supported by all Security Domains.

Annex A (normative): BER-TLV tags

Table A.1: BER-TLV tags

Description	Length of tag	Value
Command Scripting template tag for definite length coding	1	Defined in ETSI TS 101 220 [5]
Response Scripting template tag for definite length coding	1	Defined in ETSI TS 101 220 [5]
Command Scripting template tag for indefinite length coding	1	Defined in ETSI TS 101 220 [5]
Response Scripting template tag for indefinite length coding	1	Defined in ETSI TS 101 220 [5]
Number of executed command TLV objects tag	1	Defined in ETSI TS 101 220 [5]
Bad format TLV tag	1	Defined in ETSI TS 101 220 [5]
Immediate Action tag	1	Defined in ETSI TS 101 220 [5]
Immediate Action Response tag	1	Defined in ETSI TS 101 220 [5]
Error Action tag	1	Defined in ETSI TS 101 220 [5]
Script Chaining tag	1	Defined in ETSI TS 101 220 [5]
Script Chaining Response tag	1	Defined in ETSI TS 101 220 [5]

Annex B (informative): RFM over HTTP Communication Flow

Figure B.1 illustrates an RFM process communication flow over a TLS connection (established over a BIP TCP connection as specified in ETSI TS 102 223 [3] or a direct IP connection as specified in ETSI TS 102 483 [20]). The TCP connection opening is typically triggered by a triggering message following the format specified in Amendment B of the GlobalPlatform Card Specification [19].

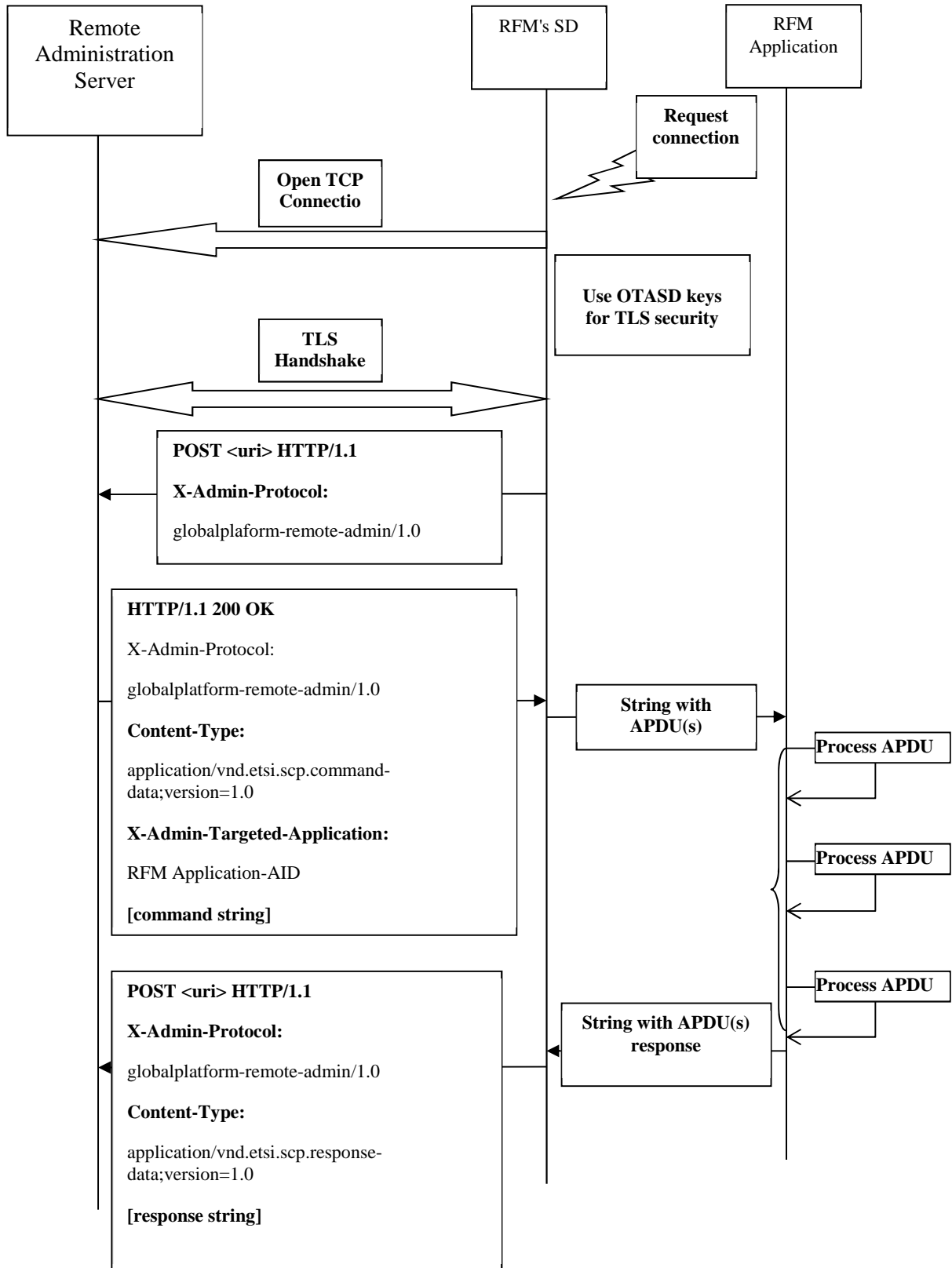

Figure B.1

Annex C: Void

Annex D (informative): RFM over CoAP/DTLS Communication Flow

Figure D.1 illustrates an RFM process communication flow over a DTLS connection (established over a BIP UDP link as specified in ETSI TS 102 223 [3] or a direct IP connection as specified in ETSI TS 102 483 [20]). The UDP/DTLS link opening is typically triggered by a triggering message following the format specified in Amendment M of the GlobalPlatform Card Specification [29].

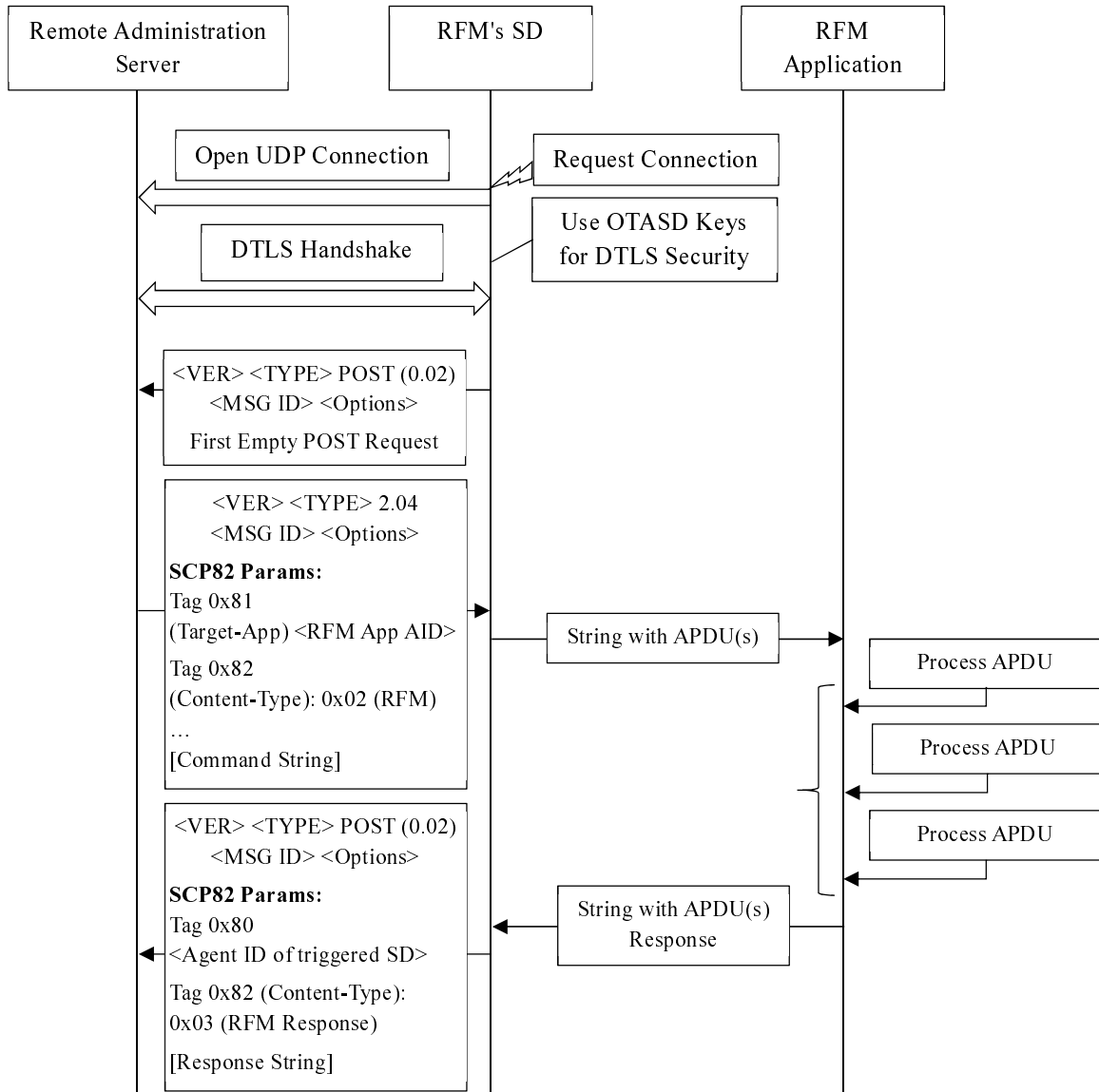

Figure D.1: RFM process communication flow over a DTLS connection

Annex E (informative): RAM over CoAP/DTLS Communication Flows

E.1 Communication Flow between an AP (Owning a RAS) and its APSD

The actors and on-card components involved in this scenario are:

- the Application Provider (AP) owning a Remote Administration Server; and
- the Security Domain of the Application Provider (APSD) having PSK DTLS keys.

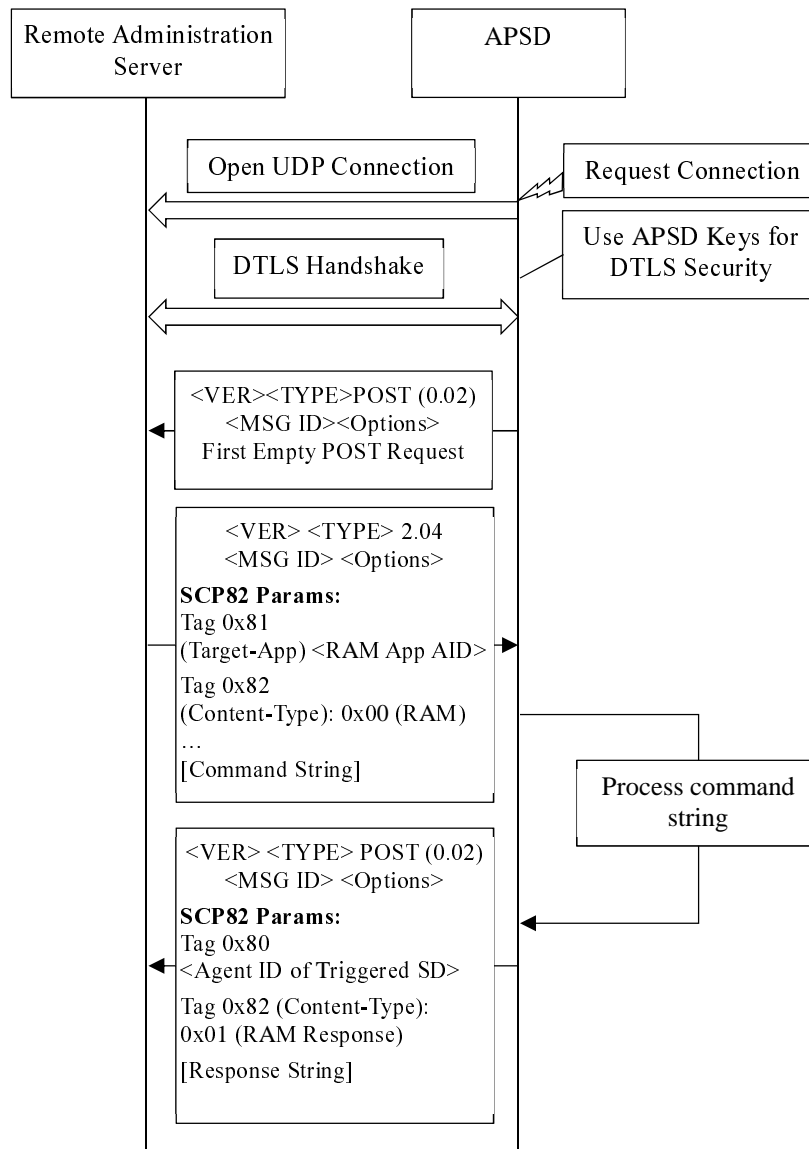

Figure E.1.1: Communication Flow between an AP (Owning a RAS) and its APSD

E.2 Communication Flow between an AP and its APSD through a Third Party RAS

The actors and on-card components involved in this scenario are:

- the Application Provider (AP); and
- the Remote Administration Server, owned by another entity; and
- the Security Domain in charge of the PSK DTLS security, having PSK DTLS keys (OTASD); and
- the Security Domain of the Application Provider (APSD) supporting SCP03 for securing the APDUs, if required.

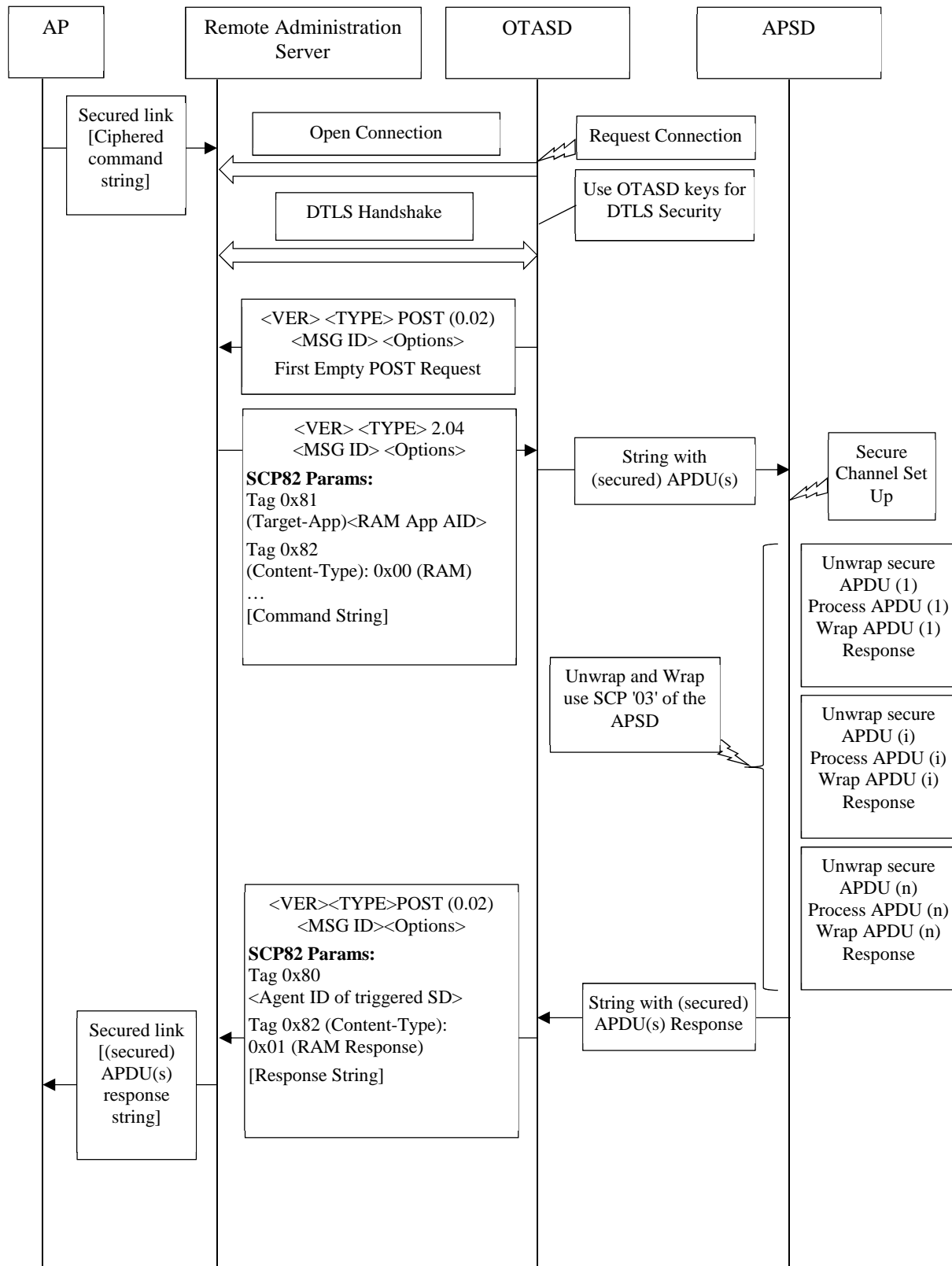

Figure E.2.1: Communication Flow between an AP and its APSD through a Third Party RAS

Annex F (informative): Change history

This annex lists all changes made to the present document.

Change History								
Date	Meeting	Tdoc	CR	Rv	Cat	Changes	Old	New
2001-07	T3 API -7	T3a010114				Initial version is based on 3GPP TS 23.048 V4.0.0. Submitted to EP SCP#7 for information.	-	0.0.0
2001-10	SCP2-1	SCP2-010004				Alignment with 3GPP TS 23.048 V5.1.0 and editorial enhancements.	0.0.0	0.1.0
2001-10	T3 API -9	T3a010196				Updated to include the results of EP SCP WG2 #1.	0.1.0	0.2.0
2001-11	T3-21/ SCP-8	T3-010670/ SCP-010346				Submitted to 3GPP T3#21 - EP SCP#8. Editorial changes.	0.2.0	0.2.1
2001-11	SCP-8	SCP-010377				Editorial and formatting enhancements. Version number raised to 1.0.0 in line with decision at EP SCP #8.	0.2.1	1.0.0
2002-01	SCP2-2	SCP2-020019				Updated to include the results of TSG-T#14 and editorial changes.	1.0.0	1.1.0
2002-03	SCP-9	SCP-020049				Updated to include the results of TSG-T#15 and editorial changes. Submitted to SCP#9 for approval.	1.1.0	2.0.0
2002-03	SCP-9	SCP-020057				Editorial changes after discussion at SCP#9. This version has been sent to the ETSI secretariat for publication in March 2002 as ETSI TS 102 226 V6.0.0. No technical changes compared to V2.0.0.	2.0.0	6.0.0
2002-06	SCP-10	SCP-020169	001	1	B	Definition of the TAR Value(s) parameter in the Application Specific Parameters of the Install(Install) command.	6.0.0	6.1.0
2002-09	SCP-11	SCP-020232	003		A	Toolkit Access with modified secret code status	6.1.0	6.2.0
			004		A	Minimum Security Level for the Remote Management Applications and Access conditions for Remote File Management Application.		
			005		A	Clarification on Put Key command		
			006		A	Maximum number of channels allowed for this applet instance		
			007		A	Clarification on letter 'n' describing the length of parameters of the Install(Install) command		
		SCP-020237						
2003-01	SCP-12	SCP-030022	008		D	Deletion of the load command example.	6.2.0	6.3.0
2003-05	SCP-13	SCP-030173	009	1	A	Clarification of the Install(Install) command in case of installing a non Toolkit Applet	6.3.0	6.4.0
2003-09	SCP-14	SCP-030225	010		B	Modification of commands for remote application management	6.4.0	6.5.0
			011		B	Menu Entries Position		
2003-12	SCP-15	SCP-030464	016	1	F	Clarification on case 4 command handling	6.5.0	6.6.0
		SCP-030465	015	2	C	Remote command coding with P3="00"		
		SCP-030466	017	1	B	Addition of Push for CAT_TP		
		SCP2-030247	013	1	B	Update of ETSI TS 102 226 to GlobalPlatform Card Specification version 2.1.1		
		SCP2-030248	014		F	Clarification of the description of Remote Management Applications		
SCP2-030268	018		B	Addition of the CREATE command for Remote File Management.				
2004-02	SCP-16	SCP2-040040	022		B	Remote File Management definitions	6.6.0	6.7.0
		SCP-040094	023		B	Introduction of UICC toolkit and access domain parameters		
		SCP-040100	024	2	F	Clarification for READ BINARY with P3='00'		
		SCP2-040052	026		B	Addition of the DELETE FILE command for Remote File Management		

Change History								
Date	Meeting	Tdoc	CR	Rv	Cat	Changes	Old	New
		SCP2-040053	027		B	Addition of the RESIZE command for Remote File Management.		
		SCP2-040058	030		F	Correction of behaviour for responses in Push for CAT_TP		
2004-05	SCP-17	SCP-040219	031	2	B	Expanded Remote Application data format	6.7.0	6.8.0
		SCP-040219	032		D	Renaming of Resize command to Resize File		
		SCP-040266	033	1	D	Editorial corrections after integration of change requests		
		SCP-040267	034	1	F	Alignment of Get Data command with GlobalPlatform		
		SCP-040219	035		B	Clarify Access Domain DAP for UICC Shared File System		
		SCP-040219	036		B	Specification of the UICC Toolkit parameters DAP		
		SCP-040272	037	2	B	Introduction of SCP Registry Data (TLV) for Get Status		
2004-09	SCP-18	SCP-040324	039		F	Correction to the commands coding description of the PUSH command	6.8.0	6.9.0
			040		F	Clarification on Max SDU size		
			041		B	Introduction of Administrative Access Domain		
		SCP-040370	038	1	F	Wrong values of BER-TLV tags in annex A		
2004-09	SCP-19	SCP-040418	042		F	Clarification for non-specific references	6.9.0	6.10.0
			043		F	Correction of Status Word and clarification for truncated responses		
2005-01	SCP-20	SCP-050018	044		F	Clarification of presence of access parameters	6.10.0	6.11.0
2005-09	SCP-22	SCP-050243	045		F	Correction to status words sent back in the Remote Management Application response data in case data is truncated	6.11.0	6.12.0
			046		F	Clarification of data sent in compact remote response		
2006-05	SCP-25	SCP-060132	048		B	Mandatory support of responses to push commands	6.12.0	7.0.0
2006-07	SCP-26	SCP-060257	048		A	Clarification of the presence of the last R-APDU	7.0.0	7.1.0
			049	1	D	Correction of abbreviation		
		SCP-060280	050	1	B	Reservation of an application specific P1 value in the PUSH command		
2006-09	SCP-27	SCP-060471	051	1	A	Correction of the release for references	7.1.0	7.2.0
		SCP-060472	054	1	B	Add new response TLV in case of a bad formatted C-APDU.		
2007-01	SCP-29	SCP-070053	055		B	Action TLVs in Command Scripting Template	7.2.0	7.3.0
2007-05	SCP-30	SCP-070137	058		F	Clarification on BIP Open Channel parameters in Push command	7.3.0	7.4.0
2007-08	SCP-32	SCP-070317	060		A	Correction of the coding of the SCP Registry Data	7.4.0	7.5.0
2008-09	SCP-32	SCP-070317	060		A	Correction of the coding of the SCP Registry Data (reimplemented)	7.5.0	7.5.1
2008-11	SCP-33	SCP-070442	053	4	B	Remote Management with Script chaining	7.5.1	7.6.0
2008-11	SCP-39	SCP-080428	061		B	Addition of AES to PUT KEY command	7.6.0	8.0.0
2008-11	SCP-39	SCP-080428	062		B	Automatic application data format detection	7.6.0	8.0.0
2009-01	SCP-40	SCP-090053	063		C	Update to GlobalPlatform Card Specification v2.2	8.0.0	8.1.0
2009-01	SCP-40	SCP-090024	064		B	Creation and replacement of DAP key	8.0.0	8.1.0
2009-01	SCP-40	SCP-090024	067		F	Clarification of encryption mode for key values	8.0.0	8.1.0
2009-05	SCP-41	SCP-090117	068		B	Modification of Install(Install) for Applets registered to the Smart Card Web Server using Toolkit resources	8.1.0	8.2.0
2009-05	SCP-41	SCP-090117	070		A	Correction of script chaining	8.1.0	8.2.0
2009-05	SCP-41	SCP-090117	071	2	B	Support of Confidential Card Content Management	8.2.0	9.0.0
2009-07	SCP-42	SCP-090228	072		B	Clarification of confidential application management	9.0.0	9.1.0
2009-10	SCP-43	SCP-090326	074		B	Remote Management over HTTPS	9.1.0	9.2.0
2009-10	SCP-43	SCP-090326	075		B	Indefinite length coding for remote command and response structures	9.1.0	9.2.0
2009-10	SCP-43	SCP-090326	073		B	Script chaining for RAM	9.1.0	9.2.0

Change History								
Date	Meeting	Tdoc	CR	Rv	Cat	Changes	Old	New
2009-10	SCP-43	SCP-090326	076		B	Addition of push mechanism for TCP	9.1.0	9.2.0
2009-10	SCP-43	SCP-090326	077		B	Support of Constrained Load File list in the STORE DATA Command	9.1.0	9.2.0
2009-10	SCP-43	SCP-090326	078		B	Addition of confidential setup of Security Domains	9.1.0	9.2.0
2010-03	SCP-44	SCP(10)0085	077	1	B	Support of Constrained Load File list in the STORE DATA Command (with corrections)	9.1.0	9.2.0
2010-03	SCP-44	SCP(10)0034	080		B	Addition of install parameters for contactless applications	9.1.0	9.2.0
2010-04	SCP-45	SCP(10)0146	081		F	Correction of one statement for response structures using indefinite length coding	9.2.0	9.3.0
2010-04	SCP-45	SCP(10)0146	082		F	Correction of scenario 1	9.2.0	9.3.0
2011-09	SCP-52	SCP(11)0285r2	083	1	F	Correction of install parameters of contactless applications	9.3.0	9.4.0
2011-09	SCP-52	SCP(11)0286r2	084	1	F	Correction of install parameters length coding	9.3.0	9.4.0
2011-12	SCP-53	SCP(11)0374	086		A	Clarification of Chapter PUT KEY for AES	9.3.0	9.4.0
2012-02						Rel-10 of the specification is created as a step in creation of Rel-11. No changes in the technical content compared to V9.4.0	9.4.0	10.0.0
2011-12	SCP-53	SCP(11)0375r1	087	1	B	Addition of scenario 3 for confidential setup of Security Domains	10.0.0	11.0.0
2011-12	SCP-53	SCP(11)0376r1	088	1	F	Clarification on Number of executed command TLV object	10.0.0	11.0.0
2012-03	SCP-54	SCP(12)000011r1	089	1	C	Clarifications concerning the command session	11.0.0	11.1.0
2012-03	SCP-54	SCP(12)000081	093		A	Update of references to GlobalPlatform specifications	11.0.0	11.1.0
2012-09	SCP-56	SCP(12)000153r1	097		A	Clarification of Extended Card resources information	11.1.0	11.2.0
2012-09	SCP-56	SCP(12)000156r1	100		A	Length coding for 'EA' and 'CA' TLVs	11.1.0	11.2.0
2012-09	SCP-56	SCP(12)000150	094		F	Correction of reference to SCP02 encapsulated in other SCPs	11.1.0	11.2.0
2012-09	SCP-56	SCP(12)000157	101		F	Clarification concerning GET DATA	11.1.0	11.2.0
2012-12	SCP-57	SCP(12)000260	102		F	Clean-up of inaccuracies related to the MSL	11.1.0	11.2.0
2013-10	SCP-61	SCP(13)000233	103		C	Modification of Response Packet sending when MSL is insufficient	11.2.0	12.0.0
2013-10	SCP-61	SCP(13)000235	104		B	Access to CASD and update to new CL mechanisms in GP Amd. C	11.2.0	12.0.0
2013-10	SCP-61	SCP(13)000236	105		C	Update of reference to GlobalPlatform Amendment B	11.2.0	12.0.0
2014-02	SCP-62	SCP(14)000041r1	106	1	C	CR 102 226 R12 #106r1: Functional modification of RAM Application taking Security Domains into account.	11.2.0	12.0.0
2014-12	SCP-66	SCP(14)000280	107		C	CR 102 226 R12 #107: Card Emulation And Reader Mode Made Optional	11.2.0	12.0.0
2015-02	SCP-67	SCP(15)000045	108		B	AES for confidential application management (CR renumbered to 108)	12.0.0	13.0.0
2015-07	SCP-69	SCP(15)000172	109		C	PUT KEY for triple DES	12.0.0	13.0.0
2015-07	SCP-69	SCP(15)000173	110		D	Clarification about the support for random card challenge mode	12.0.0	13.0.0
2015-12	SCP-71	SCP(15)000271	111		B	New installation parameter to configure access to CLT activity listener feature	12.0.0	13.0.0
2016-02	SCP-72	SCP(16)000017	112		F	Correction of error condition for Command TLV length	12.0.0	13.0.0
2016-04	SCP-73	SCP(16)000086r1	113	1	F	Update of references to GlobalPlatform specifications	13.0.0	13.1.0
2016-04	SCP-73	SCP(16)000097	114		C	Removal of reference to Global Platform/Open Platform Card Specification 2.0.1	13.0.0	13.1.0
2016-04						Addition of section headers where required to avoid hanging paragraphs (as required by latest drafting rules)	13.0.0	13.1.0
2016-10	SCP-75	SCP(16)000187	115		F	Clarification of the description of the Expanded Remote response structure	13.0.0	13.1.0
2016-12	SCP-76	SCP(16)000232	116		F	Correction of references to GlobalPlatform Card Specification V2.3	13.0.0	13.1.0

Change History								
Date	Meeting	Tdoc	CR	Rv	Cat	Changes	Old	New
2016-12	SCP-76	SCP(16)000233r1	117	1	F	Clarifications regarding usage of additional application provider security	13.0.0	13.1.0
2020-12						Automatic Upgrade	13.1.0	14.0.0
2020-12						Automatic Upgrade	14.0.0	15.0.0
2020-06	SCP-91	SCP(19)000233r1	118	1	D	Correction to definition of CASD	13.1.0	16.0.0
2020-12						Minor editorial correction	16.0.0	16.0.1
2022-10	SET-107	SET(22)000207	121	-	F	Update the reference to GlobalPlatform UICC Configuration to V2.0	16.0.1	16.1.0
2022-09	SET-106	SET(22)000095	119	-	F	Clarification on the use of the Compact Remote Application data format	16.1.0	17.0.0
2022-09	SET-106	SET(22)000117	120	-	B	Update of references to GlobalPlatform specifications	17.0.0	18.0.0
2023-09	SET-108	SET(22)000258	122	-	F	Correction of reference to NIST SP 800-38B	18.0.0	18.1.0
2023-09	SET-109	SET(23)000028	123	-	C	Updates of cryptographic algorithm support	18.0.0	18.1.0
2023-09	SET-109	SET(23)000029	124	-	D	Clarification of Menu entry list for Get Status command	18.0.0	18.1.0
2023-03	SET #111	SET(23)000072	125	-	F	Clarifications related to support of RFM commands	18.1.0	18.2.0
2024-06	SET#114	SET(24)000099	128	-	A	Correction of formatting in table 8.2	18.2.0	18.3.0
2024-10	SET#115	SET(24)000125	129	-	F	Remove Annex C	18.3.0	18.4.0
2024-10	SET#115	SET(24)000126	130	-	C	Deprecation of 3DES	18.3.0	18.4.0
2024-12	SET#116	SET(24)000154	133	-	C	Update of minimum key sizes for RSA based mechanisms	18.4.0	18.5.0
2025-09	SET #119	SET(25)000072	134	-	B	Addition of RAM and RFM over SCP82	18.5.0	19.0.0

History

Document history		
V19.0.0	November 2025	Publication