



**Environmental Engineering (EE);
Metrics and Measurement Method for Energy Efficiency of
Wireless Access Network Equipment;
Part 2: Energy Efficiency - dynamic measurement method**

Reference

RTS/EE-EEPS73

Keywords

energy efficiency, LTE

ETSI

650 Route des Lucioles
F-06921 Sophia Antipolis Cedex - FRANCE

Tel.: +33 4 92 94 42 00 Fax: +33 4 93 65 47 16

Siret N° 348 623 562 00017 - APE 7112B
Association à but non lucratif enregistrée à la
Sous-Préfecture de Grasse (06) N° w061004871

Important notice

The present document can be downloaded from:
<https://www.etsi.org/standards-search>

The present document may be made available in electronic versions and/or in print. The content of any electronic and/or print versions of the present document shall not be modified without the prior written authorization of ETSI. In case of any existing or perceived difference in contents between such versions and/or in print, the prevailing version of an ETSI deliverable is the one made publicly available in PDF format at www.etsi.org/deliver.

Users of the present document should be aware that the document may be subject to revision or change of status. Information on the current status of this and other ETSI documents is available at <https://portal.etsi.org/TB/ETSIDeliverableStatus.aspx>

If you find errors in the present document, please send your comment to one of the following services:
<https://portal.etsi.org/People/CommitteeSupportStaff.aspx>

If you find a security vulnerability in the present document, please report it through our Coordinated Vulnerability Disclosure Program:
<https://www.etsi.org/standards/coordinated-vulnerability-disclosure>

Notice of disclaimer & limitation of liability

The information provided in the present deliverable is directed solely to professionals who have the appropriate degree of experience to understand and interpret its content in accordance with generally accepted engineering or other professional standard and applicable regulations.

No recommendation as to products and services or vendors is made or should be implied.

No representation or warranty is made that this deliverable is technically accurate or sufficient or conforms to any law and/or governmental rule and/or regulation and further, no representation or warranty is made of merchantability or fitness for any particular purpose or against infringement of intellectual property rights.

In no event shall ETSI be held liable for loss of profits or any other incidental or consequential damages.

Any software contained in this deliverable is provided "AS IS" with no warranties, express or implied, including but not limited to, the warranties of merchantability, fitness for a particular purpose and non-infringement of intellectual property rights and ETSI shall not be held liable in any event for any damages whatsoever (including, without limitation, damages for loss of profits, business interruption, loss of information, or any other pecuniary loss) arising out of or related to the use of or inability to use the software.

Copyright Notification

No part may be reproduced or utilized in any form or by any means, electronic or mechanical, including photocopying and microfilm except as authorized by written permission of ETSI.

The content of the PDF version shall not be modified without the written authorization of ETSI.
The copyright and the foregoing restriction extend to reproduction in all media.

© ETSI 2024.
All rights reserved.

Contents

Intellectual Property Rights	5
Foreword.....	5
Modal verbs terminology.....	5
Introduction	5
1 Scope	7
2 References	7
2.1 Normative references	7
2.2 Informative references.....	8
3 Definition of terms, symbols and abbreviations.....	9
3.1 Terms.....	9
3.2 Symbols.....	9
3.3 Abbreviations	9
4 Assessment method	10
5 Reference configurations and Measurement requirements	11
5.1 Reference configurations.....	11
5.2 Measurement and test equipment requirements	12
5.3 BS Configuration.....	13
5.4 Transmit Signal and RF output power.....	13
5.5 UE Emulator requirements and settings	13
5.6 Environmental conditions.....	14
5.7 Power supply	14
6 Dynamic Energy Efficiency Assessment	14
6.1 Overview	14
6.2 Energy Efficiency Measurement	15
6.2.1 Measurement Lab Setup	15
6.2.2 UE Distribution.....	15
6.2.3 Data Traffic Model	16
6.2.4 Test Time Definition.....	17
6.2.5 Low traffic model	17
6.2.6 Medium traffic model	17
6.2.7 Busy-hour traffic model.....	17
6.2.8 Data Volume Measurement	17
6.2.9 Power and Energy Consumption Measurement.....	18
6.2.10 Energy Consumption measurement	18
6.2.11 Base Station Energy Efficiency KPI.....	19
6.2.12 UE quality of service KPI.....	19
7 Uncertainty	20
8 Measurement report.....	20
Annex A (normative): Test Reports	21
A.1 General information to be reported	21
A.2 Base Station Energy Efficiency report	22
Annex B (normative): Reference parameters for LTE system	24
Annex C (normative): Data Traffic Model	25
C.1 Data Traffic Model.....	25
C.2 Measured data for BS Energy Efficiency KPI calculation	25

Annex D (normative):	Uncertainty assessment	27
D.1	General requirements	27
D.2	Components contributing to uncertainty	28
D.2.1	Contribution of the measurement system	28
D.2.1.1	Uncertainty Tree description.....	28
D.2.1.2	Measurement equipment.....	28
D.2.1.3	Attenuators, cables.....	28
D.2.1.4	UE emulator.....	28
D.2.1.5	Impact of environmental parameters.....	28
D.2.1.6	Impact of path loss.....	29
D.2.1.7	Data volume.....	29
D.2.1.8	Variance of device under test.....	29
D.3	Uncertainty assessment	29
D.3.1	Combined and expanded uncertainties	29
D.3.2	Cross correlation of uncertainty factors.....	30
D.3.3	Maximum expanded uncertainty	30
Annex E (informative):	Bibliography.....	31
History		32

Intellectual Property Rights

Essential patents

IPRs essential or potentially essential to normative deliverables may have been declared to ETSI. The declarations pertaining to these essential IPRs, if any, are publicly available for **ETSI members and non-members**, and can be found in ETSI SR 000 314: "*Intellectual Property Rights (IPRs); Essential, or potentially Essential, IPRs notified to ETSI in respect of ETSI standards*", which is available from the ETSI Secretariat. Latest updates are available on the ETSI Web server (<https://ipr.etsi.org/>).

Pursuant to the ETSI Directives including the ETSI IPR Policy, no investigation regarding the essentiality of IPRs, including IPR searches, has been carried out by ETSI. No guarantee can be given as to the existence of other IPRs not referenced in ETSI SR 000 314 (or the updates on the ETSI Web server) which are, or may be, or may become, essential to the present document.

Trademarks

The present document may include trademarks and/or tradenames which are asserted and/or registered by their owners. ETSI claims no ownership of these except for any which are indicated as being the property of ETSI, and conveys no right to use or reproduce any trademark and/or tradename. Mention of those trademarks in the present document does not constitute an endorsement by ETSI of products, services or organizations associated with those trademarks.

DECT™, **PLUGTESTS™**, **UMTS™** and the ETSI logo are trademarks of ETSI registered for the benefit of its Members. **3GPP™** and **LTE™** are trademarks of ETSI registered for the benefit of its Members and of the 3GPP Organizational Partners. **oneM2M™** logo is a trademark of ETSI registered for the benefit of its Members and of the oneM2M Partners. **GSM®** and the GSM logo are trademarks registered and owned by the GSM Association.

Foreword

This Technical Specification (TS) has been produced by ETSI Technical Committee Environmental Engineering (EE).

The present document is part 2 of a multi-part deliverable covering Metrics and Measurement Method for Energy Efficiency of Wireless Access Network Equipment, as identified below:

ETSI ES 202 706-1: "Power consumption - static measurement method";

ETSI TS 102 706-2: "Energy Efficiency - dynamic measurement method".

Modal verbs terminology

In the present document "**shall**", "**shall not**", "**should**", "**should not**", "**may**", "**need not**", "**will**", "**will not**", "**can**" and "**cannot**" are to be interpreted as described in clause 3.2 of the [ETSI Drafting Rules](#) (Verbal forms for the expression of provisions).

"**must**" and "**must not**" are **NOT** allowed in ETSI deliverables except when used in direct citation.

Introduction

Energy efficiency is one of the critical factors of the modern telecommunication systems which is about how much energy is going to be consumed for a certain delivered job from the network side while still having an acceptable performance. The energy consumption of the access network is the dominating part of the wireless telecom network energy consumption. Therefore, the core network and the service network are not considered in the present document. In a radio access network, the energy consumption of the Base Station is dominating (depending on technology often also referred to as BTS, NodeB, eNodeB, etc. and in the present document denoted as BS). The energy consumption of Radio Network Control nodes (RNC or BSC) are covered in ETSI ES 201 554 [i.6].

The present document defines the dynamic measurement method for evaluation of LTE BS energy efficiency:

- BS energy efficiency under dynamic load conditions: the BS capacity under dynamic traffic load provided within a defined coverage area and the corresponding energy consumption is measured for given reference configurations.

ETSI ES 202 706-1 [i.8] defines daily average power consumption of the base station, and ETSI TS 103 786 [i.9] defines energy efficiency measurement of the NR base station with dynamic load.

1 Scope

The present document covers the following radio access technology:

- LTE.

The methodology described in the present document is to measure base station dynamic energy efficiency. Within the present document, it is referred to as dynamic measurement.

The results based on dynamic measurements of the BS provide energy efficiency information for BS with dynamic load.

Energy consumption of the core network and the service network are not covered in the present document. The energy consumption of Radio Network Control nodes (RNC or BSC) are covered in ETSI ES 201 554 [i.6].

Energy consumption of user terminal (end-user) equipment is outside the scope of the present document, however, how a User Equipment (UE) affects a base station energy efficiency is an important factor and will be considered for further study.

The scope of the present document is not to set and define target values for the power consumption nor the energy efficiency of equipment and neither for regulatory nor type approval purpose.

The results should only be used to assess and compare the energy efficiency of base stations.

Wide Area Base Stations are covered in this version of the present document.

2 References

2.1 Normative references

References are either specific (identified by date of publication and/or edition number or version number) or non-specific. For specific references, only the cited version applies. For non-specific references, the latest version of the referenced document (including any amendments) applies.

Referenced documents which are not found to be publicly available in the expected location might be found at <https://docbox.etsi.org/Reference/>.

NOTE: While any hyperlinks included in this clause were valid at the time of publication, ETSI cannot guarantee their long term validity.

The following referenced documents are necessary for the application of the present document.

- [1] Void.
- [2] [ETSI EN 300 132-1](#): "Environmental Engineering (EE); Power supply interface at the input to Information and Communication Technology (ICT) equipment; Part 1: Alternating Current (AC)".
- [3] [ETSI EN 300 132-2](#): "Environmental Engineering (EE); Power supply interface at the input of Information and Communication Technology (ICT) equipment; Part 2: -48 V Direct Current (DC)".
- [4] [ETSI TS 136 211](#): "LTE; Evolved Universal Terrestrial Radio Access (E-UTRA); Physical channels and modulation (3GPP TS 36.211)".
- [5] [ETSI TS 136 104](#): "LTE; Evolved Universal Terrestrial Radio Access (E-UTRA); Base Station (BS) radio transmission and reception (3GPP TS 36.104)".
- [6] Void.
- [7] [ETSI EN 300 132-3](#): "Environmental Engineering (EE); Power supply interface at the input of Information and Communication Technology (ICT) equipment; Part 3: Up to 400 V Direct Current (DC)".

- [8] [3GPP TS 36.101 \(V18.3.0\) \(2023-09\)](#): "3rd Generation Partnership Project; Technical Specification Group Radio Access Network; Evolved Universal Terrestrial Radio Access (E-UTRA); User Equipment (UE) radio transmission and reception (Release 18)".
- [9] [ETSI TS 136 141](#): "LTE; Evolved Universal Terrestrial Radio Access (E-UTRA); Base Station (BS) conformance testing (3GPP TS 36.141)".
- [10] Void.
- [11] Void.
- [12] [IEC/ISO Guide 98-3](#): "Guide to the expression of uncertainty in measurement" (2008 or equivalent GUM:2008/JCGM 100:2008).
- NOTE: Also available at http://www.bipm.org/utils/common/documents/jcgm/JCGM_100_2008_E.pdf.
- [13] [ETSI TS 145 005](#): "Digital cellular telecommunications system (Phase 2+); Radio transmission and reception (3GPP TS 45.005)".

2.2 Informative references

References are either specific (identified by date of publication and/or edition number or version number) or non-specific. For specific references, only the cited version applies. For non-specific references, the latest version of the referenced document (including any amendments) applies.

NOTE: While any hyperlinks included in this clause were valid at the time of publication, ETSI cannot guarantee their long term validity.

The following referenced documents are not necessary for the application of the present document but they assist the user with regard to a particular subject area.

- [i.1] Void.
- [i.2] Void.
- [i.3] ISO/IEC 17025: "General requirements for the competence of testing and calibration laboratories".
- [i.4] IEC 62018: "Power consumption of information technology equipment - Measurement methods".
- NOTE: Equivalent to CENELEC EN 62018.
- [i.5] Void.
- [i.6] ETSI ES 201 554: "Environmental Engineering (EE); Measurement method for Energy efficiency of Mobile Core network and Radio Access Control equipment".
- [i.7] ETSI ES 202 336-12: "Environmental Engineering (EE); Monitoring and control interface for infrastructure equipment (power, cooling and building environment systems used in telecommunication networks); Part 12: ICT equipment power, energy and environmental parameters monitoring information model".
- [i.8] ETSI ES 202 706-1: "Environmental Engineering (EE); Metrics and measurement method for energy efficiency of wireless access network equipment; Part 1: Power Consumption - Static Measurement Method".
- [i.9] ETSI TS 103 786: "Environmental Engineering (EE); Measurement method for energy efficiency of wireless access network equipment; Dynamic energy performance measurement method of 5G Base Station (BS)".

3 Definition of terms, symbols and abbreviations

3.1 Terms

For the purposes of the present document, the following terms apply:

Base Station (BS): radio access network component which serves one or more radio cells and interfaces the user terminal (through air interface) and a wireless network infrastructure

BS test control unit: unit which can be used to control and manage BS locally in a lab

busy hour (load): period during which occurs the maximum total load in a given 24-hour period

distributed BS: BS architecture which contains remote radio heads (i.e. RRH) close to antenna element and a central element connecting BS to network infrastructure

efficiency: throughout the present document the term efficiency is used as the relation between the useful output (telecom service, etc.) and energy consumption of the BS

energy efficiency: Throughout the present document the term energy efficiency is used as the relation between the useful output (telecom service, etc.) and energy consumption of the BS. In more details, the ratio between the produced task or work and the consumed power for producing this task or work over a time period is called energy efficiency. The task or work could be anything and in telecommunication it can for example be the delivered bits to a User Equipment (UE). In this case the unit could be for example [Mbits / kWh] or [bits / kWh] or [Mbits / Joules]. Since the electricity bills for operators are normally presented in kWh and the work can be expressed as delivering Mbits to a user it would be more convenient to express the unit as [Mbits / kWh].

integrated BS: BS architecture in which all BS elements are located close to each other; for example, in one single cabinet

NOTE: The integrated BS architecture may include Tower Mount Amplifier (TMA) close to antenna.

low load: lowest generated traffic during the dynamic measurement period

medium load: medium load between the lowest and busy hour load generated during the dynamic measurement period

power saving feature: software/hardware feature in a BS which contributes to decrease power consumption

static measurement: power consumption measurement performed with different radio resource configurations with pre-defined and fixed load levels

NOTE: See ETSI ES 202 706-1 [i.8].

UE group: group of UEs whose path losses to the BS are identical

wide area base station: base station that is characterized by a Rated output Power (PRAT) greater than 38 dBm

NOTE: See ETSI TS 136 104 [5].

3.2 Symbols

Void.

3.3 Abbreviations

For the purposes of the present document, the following abbreviations apply:

AC	Alternating Current
BH	Busy Hour
BS	Base Station
BSC	Base Station Controller

BSEE	Base Station Energy Efficiency
BTS	Base Transceiver Station
BW	Bandwidth
CCE	Control Channel Element
DC	Direct Current
DL	DownLink
DUT	Device Under Test
E2E	End to End
EPRE	Emitted Power per Resource Element
ERRH	Energy for Remote Radio Head
E-UTRA	Evolved Universal Terrestrial Radio Access Network
EVA	Extended Vehicular A model
FDD	Frequency-Division Duplexing
HSPA	High Speed Packet Access
HW	HardWare
kPa	kilo pascal
KPI	Key Performance Indicator
LTE	Long Term Evolution
MIMO	Multiple Input Multiple Output
NIST	National Institute of Standards and Technology
NR	New Radio
PBCH	Packet Broadcast Control Channel
PCM	Pulse Code Modulation
PDCCH	Physical Downlink Control CHannel
PDSCH	Physical Downlink Shared CHannel
PRAT	Rated output power
PRB	Physical Resource Block
PSS	Primary Synchronizing Signal
PT	Probability Time
REG	Resource Element Group
RF	Radio Frequency
RNC	Radio Network Controller
RRH	Remote Radio Head
RS	Reference Signals
RX	Receiver
S/W	SoftWare
SDH	Synchronous Digital Hierarchy
SIMO	Single Input Multiple Output
SSS	Secondary Synchronizing Signal
SW	SoftWare
TCP	Transmission Control protocol
TM1	Transmission Mode 1
TMA	Tower Mount Amplifier
TX	Transmitter
UE	User Equipment
UL	UpLink
WT	Waiting Time

4 Assessment method

The assessment method is covering the BS equipment dynamic energy efficiency for which the present document defines reference BS equipment configurations and reference load levels to be used when measuring BS energy efficiency.

The assessment procedure contains the following tasks:

- 1) Identification of equipment under test:
 - 1.1 Identify BS basic parameters (Table A.1).
 - 1.2 List BS configuration (Annexes A and B).

- 1.3 List traffic load(s) for measurements (Annex C).
- 1.4 List of used power saving features and capacity enhancement features.
- 2) Energy efficiency measurement under dynamic load conditions, Measure BS equipment delivered task in terms of bits and the consumed energy under required conditions (see clause 6).
- 3) Collect and report the energy efficiency measurement results.

5 Reference configurations and Measurement requirements

5.1 Reference configurations

Reference configurations are defined for LTE in Annex B.

These configurations include integrated and distributed BS, mast head amplifiers, remote radio heads, RF feeder cables, number of carriers, number of sectors, power range per sector, frequency range, diversity, MIMO.

The BS shall be tested with its intended commercially available configuration at temperatures defined in clause 5.6. It shall be clearly reported in the measurement report if the BS cannot be operated without additional air-conditioning at the defined temperatures.

Appropriate transmission e.g. a transport function or other providing capacity corresponding to the BS capacity, shall be included in the BS configuration during testing. The configurations include:

- 1) UL diversity (this is a standard feature in all BS. Therefore, it is considered sufficient that the test is performed on the main RX antenna only. The diversity RX shall be active during the measurement without connection to the test signal).
- 2) DL diversity: Transmission mode 3 "Open loop spatial multiplexing" shall be according to ETSI TS 136 211 [4] (2×2 DL MIMO)).

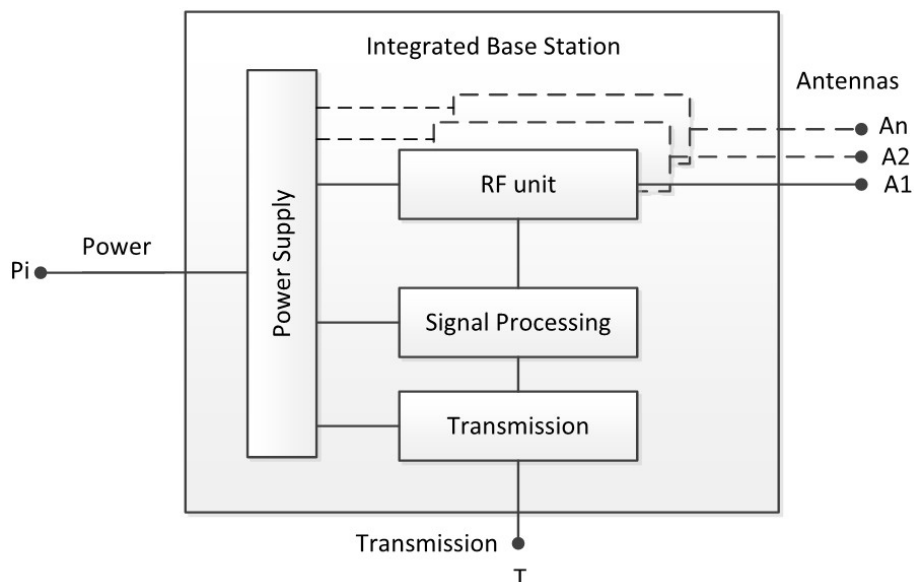

Figure 1: Integrated BS model

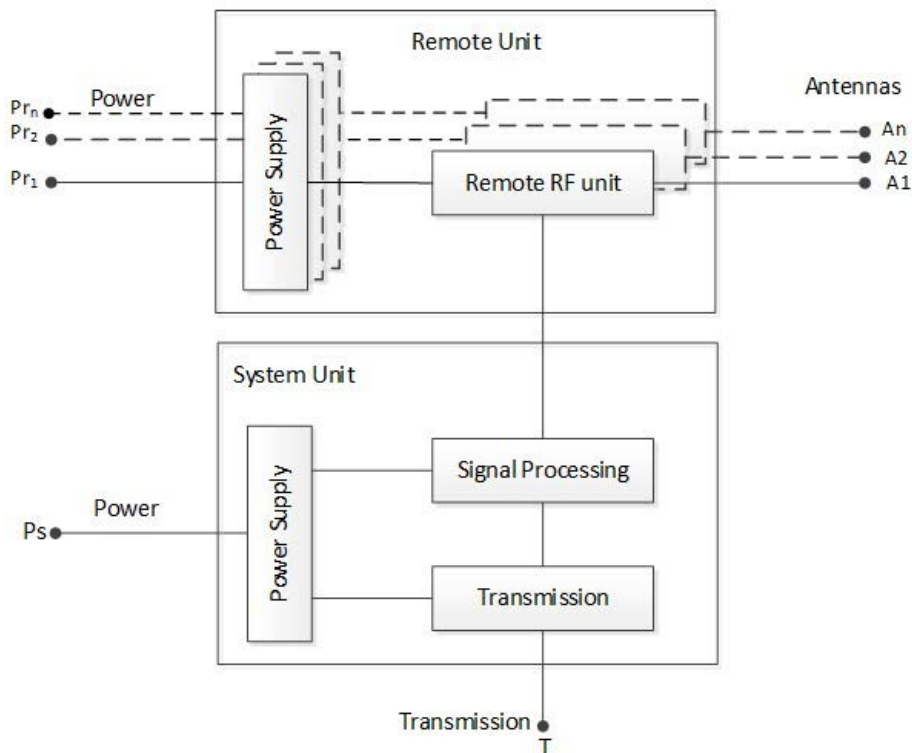

Figure 2: Distributed BS model

5.2 Measurement and test equipment requirements

The measurement of the power consumption shall be performed by either measuring the power supply voltage and true effective current in parallel and calculate the resulting power consumption (applicable only for DC) or with a wattmeter (applicable for both AC and DC). The measurements can be performed by a variety of measurement equipment, including power clamps, or power supplies with in-built power measurement capability.

All stand-alone measurement equipment such as power measurement instruments, shall be calibrated and shall have data output interface to allow long term data recording and calculation of the complete power consumption over a dedicated time.

The stand-alone measurement equipment shall comply with the following attributes:

- Input power:
 - Resolution: $\leq 10 \text{ mA}$; $\leq 100 \text{ mV}$; $\leq 100 \text{ mW}$.
 - DC current: $\pm 1 \%$.
 - DC voltage: $\pm 1 \%$.
 - AC power: $\pm 1 \%$:
 - An available current crest factor of 5 or more.
 - The test instrument shall have a bandwidth of at least 1 kHz.

NOTE: Additional information on accuracy can be found in IEC 62018 [i.4].

- RF output power accuracy: $\pm 0,4 \text{ dB}$.

The above requirements are not applied to any internal measurement mechanism build in a base station [i.7]. The above requirements shall be applied to stand-alone equipment such as power measurement instruments.

5.3 BS Configuration

The BS shall be tested under normal test conditions according to the information accompanying the equipment. The BS, test configuration and mode of operation (baseband, control and RF part of the BS as well as the software and firmware) shall represent the normal intended use and shall be recorded in the test report.

The BS shall be tested with its typical configuration. In case of multiple configurations, a configuration with 3 sectors shall be used.

EXAMPLE: A typical wide area BS configuration consists of three sectors and shall therefore be tested in a three-sector configuration. If a BS is designed for dual or single sector applications, it shall be tested in its designed configuration.

The connection to the simulator via the BS controller interface shall be an electrical or optical cable-based interface (e.g. PCM, SDH and Ethernet) which is commercially offered along with the applied BS configuration.

Additional power consuming features like battery loading shall be switched off.

The used power saving features and SW version shall be listed in the measurement report.

The measurement report shall state the configuration of the BS, for example the type of RF signal combining (antenna network combining, air combining or multi-carrier).

5.4 Transmit Signal and RF output power

The maximum RF transmit power that the base station under test is capable of shall be reported.

The base station under test shall control the RF transmit signal to fulfil the traffic profiles as listed in Annex B.

The power amplifier(s) of the BS shall support the same crest factor (peak to average ratio) and back-off as applied in the commercial product.

All relevant requirements from 3GPP specifications for the LTE air-interface shall be fulfilled.

5.5 UE Emulator requirements and settings

UE power consumption is not considered in the present document. However, UE category and performance has a significant impact on the base station energy efficiency. To assess energy efficiency of the BS, the UE capabilities represented by the UE emulator shall be used as follows:

- The UE emulator shall provide the total capacity (number of simultaneous UEs as defined in Annex C, max data rate, etc.) to load the BS per test specification.
- The UE emulator shall be capable of supporting at least LTE release 12.
- Multiband radio interface support 400 - 4 000 MHz.
- Simulation capacity of at least 100 UE.
- Full stack E2E UE simulation.
- Capability of Mobility simulation.
- Fading simulation capability (according to 3GPP models).
- Possibility to control every UE position (pathloss), data traffic, fading and other radio channel behaviour individually.
- Logging of UE performance.

The used UE emulator type shall be recorded in detail for the test protocol. This shall include the brand name of UE emulator, the model, HW and S/W versions.

5.6 Environmental conditions

For the BS energy efficiency measurements, the environmental conditions under which the BS shall be tested are defined as follows.

Table 1: BS environmental conditions

Condition	Minimum	Maximum
Barometric pressure	86 kPa (860 mbar)	106 kPa (1 060 mbar)
Relative Humidity	20 %	85 %
Vibration	Negligible	
Temperature	+25 °C	
Temperature accuracy	±2 °C	

The BS energy efficiency measurements shall be performed when stable temperature conditions inside the equipment are reached. For this purpose, the BS shall be placed in the environmental conditions for minimum two hours with a minimum operation time of one hour before doing the measurements. After change of traffic load level, a minimum operation time of one hour shall also be applied before conducting measurements again.

5.7 Power supply

For measurements of the BS power consumption the following operating voltage value shall be used (for non-standard power supply voltages one shall use the nominal equipment operating voltage with $\pm 2,5$ % tolerance).

Nominal value and operating value for AC testing shall be according to ETSI EN 300 132-1 [2] and for DC testing to ETSI EN 300 132-2 [3] and ETSI EN 300 132-3 [7].

The frequency of the power supply corresponding to the AC mains shall be according to ETSI EN 300 132-1 [2].

Power measurement is done at the input of power to the power supply unit to the base station. See Figures 1 and 2 for location of measurement point for both the integrated and distributed base station.

6 Dynamic Energy Efficiency Assessment

6.1 Overview

For dynamic measurement, the BS shall be operated in a test and measuring environment as illustrated in Figure 3.

For BS energy efficiency measurements the following items are specified for each system in Annexes B and C:

- Reference configuration (Annex B).
- Frequency bands (Annex B).
- Traffic load levels (Annex C).
- Traffic case (Annex C).

Power Savings features and other radio and traffic related features implemented in BS can be used during the testing. Such features shall be listed in the measurement report, Annex A.

The BS is powered by a DC or AC power supply. The control unit itself is connected to the core network. The core network can be either a real network element or a core network emulator.

6.2 Energy Efficiency Measurement

6.2.1 Measurement Lab Setup

Figure 3 shows the test setup using a UE emulator and a channel emulator connected to the BS under test. A traffic generator is used to generate both data traffic requested by the UEs and measuring the received data by the UEs during the test.

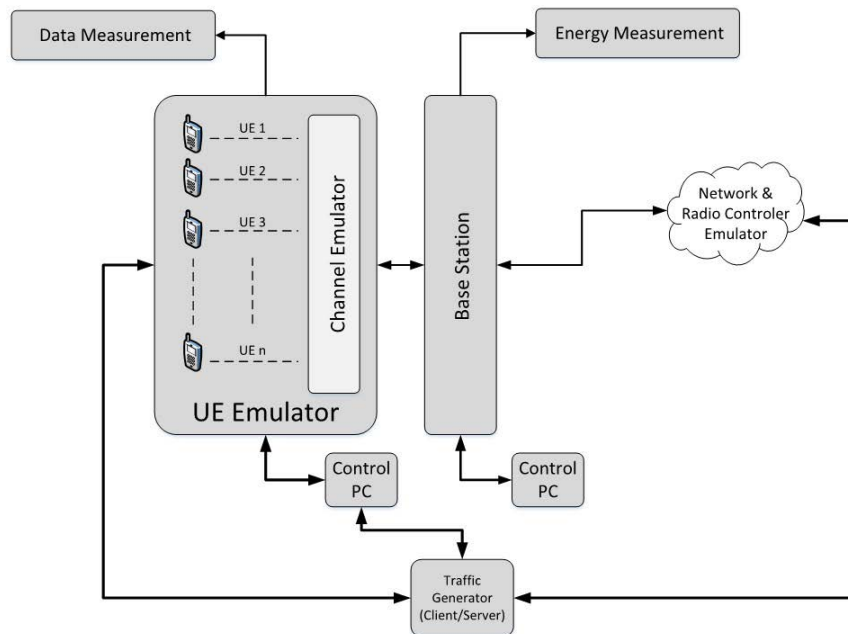

NOTE: BS as defined in Figure 1 (integrated BS) or Figure 2 (distributed BS). AC supply to be used for BS with build in AC power supply, otherwise default DC supply voltage as specified in clause 5.7.

Figure 3: Test setup for dynamic measurement with integrated BS and UE emulator

The BS shall be operated and controlled via the controller units as illustrated in Figure 3 in conjunction with the UE distribution, the traffic models and reference parameters given in Annexes B and C.

A channel emulator is used either by an in-built channel emulator in the UE emulator or as a standalone channel emulator. It is used for emulating fading over the radio channels between UEs and the BS. The fading model shall be EVA 5 Hz model according to the models specified in 3GPP TS 36.101 [8], Annex B.

6.2.2 UE Distribution

The UEs are distributed in three different path loss regions, low path loss, medium path loss and high path loss regions as shown in Figure 4. The path loss value for each region is according to Table C.3.

The number of UEs for low, medium, and busy-hour traffic load scenarios are different and are according to Annex C, Table C.3.

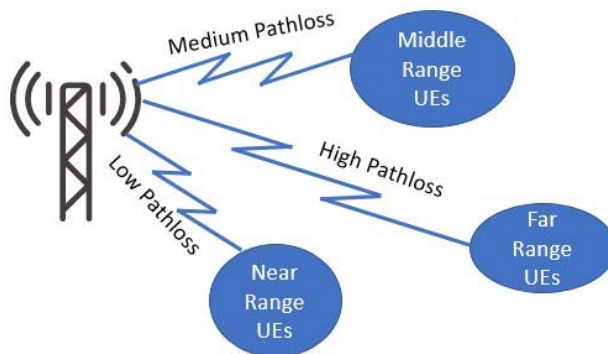

Figure 4: UE distribution in three different pathloss regions

6.2.3 Data Traffic Model

The traffic model used for BS energy efficiency measurement in the present document is based on artificially generated data traffic by a traffic generator. This traffic generator is either inbuilt in the UE emulator used in the test setup or is a standalone traffic generator. The following requirements shall be fulfilled for the data traffic model in the present document:

- The data traffic model shall be based on TCP protocol.
- Measurement results shall be repeatable within a given confidence interval of 95 %. The test time for each traffic load scenario is 60 minutes. This means that all UEs stop to request data when this time is elapsed.
- Three different file sizes, F_{small} (small size), F_{medium} (medium size) and F_{large} (large size) are defined to be randomly requested by each UE during each test scenario. These file sizes are defined in Annex C.
- Each UE continues requesting files of the above file sizes on a random basis until the end of the test time.
- The probability of requesting a file of each file size (F_{small} , F_{medium} , F_{large}) is defined in Table C.2 in Annex C and denoted as PF_{small} , PF_{medium} and PF_{large} .
- Each time a UE has received a file, the UE shall wait for a waiting time (WT_1 , WT_2 , WT_3) randomly before requesting a new file of random file size. Applying the waiting time for each UE is also on random basis according to Table C.2 in Annex C and the probability for each waiting time is denoted as PT_1 , PT_2 and PT_3 .
- All the UEs shall stay connected during the test time. The UEs shall be disconnected when the test time has ended.
- An idle state time for BS shall be applied after the test time has ended, i.e. when all the UEs have finished requesting data and disconnected the BS enters the idle state. This idle state time is defined according to Annex C.
- Startup procedure: All UEs shall be in connected mode before the test starts.
- At the end of each tested traffic load scenario the total amount of delivered data during the test time, the consumed energy during the test time, and the consumed energy during the idle state time shall be collected and reported.

Figure 5 shows an example over how different files in a random way are transmitted to each UE. All the UEs shall be in connected mode before the start of the test. At the start of the test each UE starts to request data on a random basis as explained above. The data traffic model used in the present document is based on transmitting three different file sizes denoted as small, medium, and large file sizes. The size of these files is defined in Annex C. Each UE continues requesting data until the end of the test time.

When the test time ended and all UEs disconnected the BS enters an idle state for an idle time defined according to Annex C.

The following data needs to be collected after each tested traffic load scenario:

- The energy consumption during the test time.

- The energy consumption during the idle time. Note that the idle time energy consumption shall not be included when calculating the BS Energy Efficiency KPI (see clauses 6.2.8 to 6.2.11 below).
- The total received data by the UEs during the test time.

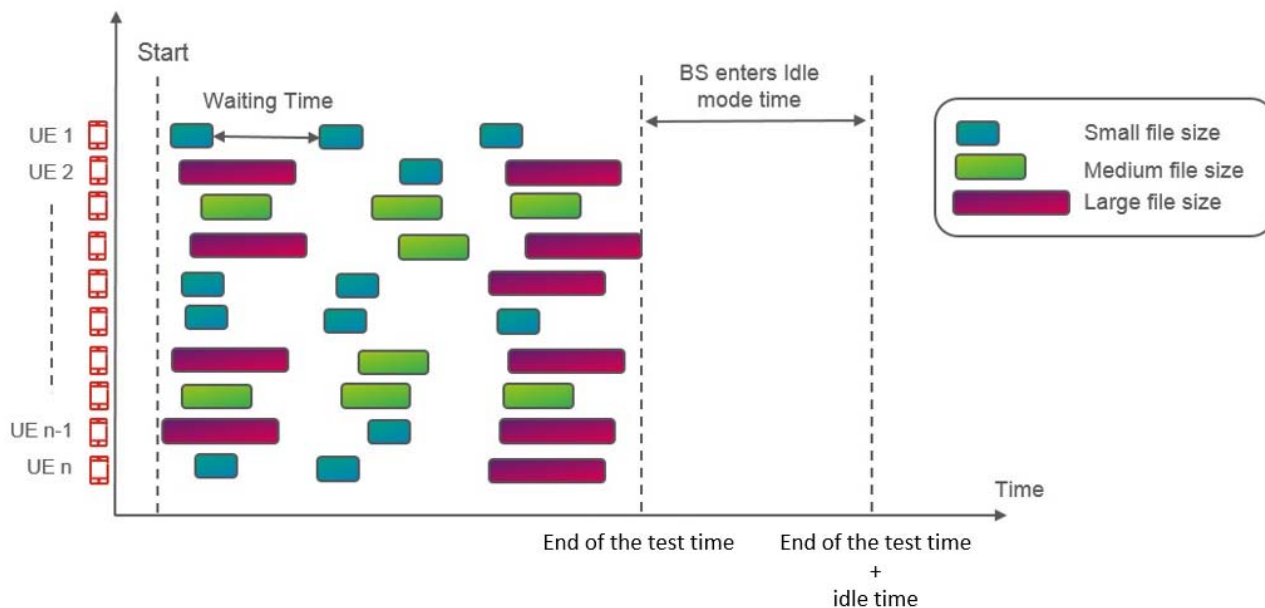

Figure 5: An Example of Data traffic flow to each UE

6.2.4 Test Time Definition

The test time is fixed according to Table C.2, Annex C. This test time is denoted as T_{test} and it is the time between the start of the measurement and the time when the UEs stop requesting files.

The test time for low, medium and busy-hour traffic load scenarios are in the following denoted as: $T_{\text{test-low}}$, $T_{\text{test-medium}}$, and $T_{\text{test-busy-hour}}$ respectively.

6.2.5 Low traffic model

For low load traffic scenario, the amount of delivered data is at a low level due to low number of connected UEs. The number of connected UEs for low load scenario is defined in Table C.3 in Annex C.

6.2.6 Medium traffic model

For medium load traffic scenario, the amount of delivered data is at a medium level due to medium number of connected UEs. The number of connected UEs for medium load scenario is defined in Table C.3 in Annex C.

6.2.7 Busy-hour traffic model

For busy-hour load traffic scenario, the amount of delivered data is at a busy-hour level due to high number of connected UEs. The number of connected UEs for busy-hour load scenario is defined in Table C.3 in Annex C.

6.2.8 Data Volume Measurement

All received data by the UEs during the test time of each traffic load scenario shall be measured. The measured data is the net data volume and shall not contain any duplicated or retransmitted data. The data shall be generated as described in clause 6.2.3 and Annex C. The measured data in Mbits will be used for calculation of the BS energy efficiency KPI.

For the calculation of the BS energy efficiency, weighting factors based on a daily (24 hours) traffic load distribution profile consisting of the three measured traffic load levels; low load (low), medium load (med), and Busy Hour (BH) load are used. A mobile network operator is allowed to define a load distribution profile reflecting the situation in the network and mandate that profile to be used. Note that the selected load durations shall sum up to 24 hours. In case no load distribution profile has been defined, the default values defined in Annex C can be used.

These weighting factors are denoted as W_{low} for low traffic load level, W_{medium} for medium traffic load level and $W_{busy-hour}$ for busy-hour traffic load level.

The measured data volume in Mbits for low load level is denoted as $DV_{measured-low}$.

The measured data volume in Mbits for medium load level is denoted as $DV_{measured-medium}$.

The measured data volume in Mbits for busy-hour load level is denoted as $DV_{measured-busy-hour}$.

The total data volume for 24-hours period is calculated as follows:

$$DV_{total} = \left(DV_{low} \times \frac{W_{low}}{T_{test\ low}} \right) + \left(DV_{medium} \times \frac{W_{medium}}{T_{test\ medium}} \right) + \left(DV_{busy\ hour} \times \frac{W_{busy\ hour}}{T_{test\ busy\ hour}} \right) [Mbits] \quad (6.1)$$

The three traffic load level scenarios shall be measured at middle frequency channel.

NOTE: Both the weighting factors and the test time have the same unit [hour].

6.2.9 Power and Energy Consumption Measurement

The energy consumption measurements shall be performed when stable temperature conditions inside the equipment are reached. For this purpose, the BS shall be placed in the environmental conditions for minimum two hours with a minimum operation time of one hour before starting the measurements. After change of traffic load level, a minimum operation time of one hour shall also be applied before conducting measurements again.

Measurement results shall be captured earliest when the equipment including the selected traffic load level is in stable operating conditions.

The RF output powers as well as the corresponding power consumptions of the BS shall be measured and collected during the whole test time according to the traffic model described in clause 6.2.3 and Annex C.

The test models as well as the different traffic load level scenarios are defined in clause 6.2.3 and Annex C.

The energy consumption of the BS shall be given in Watt hours in accordance with the accuracies and the resolutions given in clause 5.7.

The measurement expanded uncertainty shall be assessed according to Annex D.

6.2.10 Energy Consumption measurement

The energy consumption of the base station under test shall be measured during the test time of each traffic load level scenario. The total daily energy consumption of the base station will be the sum of weighted energy consumption for each traffic load level scenario, i.e. low, medium and busy-hour traffic.

For the calculation of the BS energy efficiency, weighting factors based on a daily (24 hours) traffic load distribution profile consisting of the three measured traffic load levels; low load (low), medium load (med), and Busy Hour (BH) load are used. A mobile network operator is allowed to define a load distribution profile reflecting the situation in the network and mandate that profile to be used. Note that the selected load durations shall sum up to 24 hours. In case no load distribution profile has been defined, the default values defined in Annex C can be used.

These weighting factors are denoted as W_{low} for low traffic load level, W_{medium} for medium traffic load level and $W_{busy-hour}$ for busy-hour traffic load level.

To calculate the energy consumption, the power consumption of the BS is sampled continuously (interval time Δt_m : 0,5 seconds or shorter) over the complete test time for each traffic load level.

For the integrated BS, $P_{i, \text{equipment}}^{\text{traffic_scenario}}$ is the measured power value for the i^{th} sampled measurement during the test time. The energy $E_{\text{equipment}}^{\text{traffic_scenario}}$ which is the energy consumption of the BS during the test time is calculated as follows:

$$E_{\text{equipment}}^{\text{traffic_scenario}_x} = \sum_{k=1}^n (\Delta t_m \cdot P_{k, \text{equipment}}^{\text{traffic_scenario}_x}) \text{ [kWh]} \quad (6.2)$$

For the distributed BS, $E_{C, \text{equipment}}$ and $E_{RRH, \text{equipment}}$ [kWh] are the energy consumption of the central and the remote parts in the dynamic method defined as:

$$E_{RRH, \text{equipment}}^{\text{traffic_scenario}_x} = \sum_{k=1}^n (\Delta t_m \cdot P_{k, RRH, \text{equipment}}^{\text{traffic_scenario}_x}) \text{ [kWh]} \quad (6.3)$$

$$E_{C, \text{equipment}}^{\text{traffic_scenario}_x} = \sum_{k=1}^n (\Delta t_m \cdot P_{k, C, \text{equipment}}^{\text{traffic_scenario}_x}) \text{ [kWh]} \quad (6.4)$$

where $n = \frac{T_{\text{test}_x}}{\Delta t_m}$, and T_{test_x} is the test time for each traffic load level and Δt_m is the sampling period.

The measured energy consumption in kWh for low load level is denoted as $E_{\text{equipment}}^{\text{measured-traffic_scenario_low}}$.

The measured energy consumption in kWh for medium load level is denoted as $E_{\text{equipment}}^{\text{measured-traffic_scenario_medium}}$.

The measured energy consumption in kWh for busy-hour load level is denoted as $E_{\text{equipment}}^{\text{measured-traffic_scenario_busy-hour}}$.

The total energy consumption for 24-hours period is calculated as follows:

$$E_{\text{total equipment}} = \left(E_{\text{low}} \times \frac{W_{\text{low}}}{T_{\text{test low}}} \right) + \left(E_{\text{medium}} \times \frac{W_{\text{medium}}}{T_{\text{test medium}}} \right) + \left(E_{\text{busy hour}} \times \frac{W_{\text{busy hour}}}{T_{\text{test busy hour}}} \right) \text{ [kWh]} \quad (6.5)$$

NOTE: Both the weighting factor and the test time have the same unit [hour].

For calculation of the total energy consumption for a distributed BS, similar calculations as above are carried out for both the remote radio part and the central equipment part. These two parts are then summed to obtain the total energy consumption for a distributed BS.

6.2.11 Base Station Energy Efficiency KPI

The Base Station Energy Efficiency (BSEE) KPI is an indicator for showing how a base station in an energy efficient way is doing a work in terms of delivering useful bits to the UEs served by the base station. A base station is more energy efficient when doing more work with the same energy, doing the same work with less energy or in the best case doing more work with less energy. The base station energy efficiency KPI is the ratio of delivered bits and consumed energy and is consisting of delivered useful bits in the numerator and consumed energy in the denominator.

$$BSEE = \frac{DV_{\text{total}}}{E_{\text{equipment}}^{\text{total}}} \left[\frac{\text{Mbits}}{\text{kWh}} \right] \quad (6.6)$$

where DV_{total} is the total delivered data volume in Mbits during a 24 hours period for all three traffic load levels according to clause 6.2.8 and $E_{\text{equipment}}^{\text{total}}$ is the total consumed energy during the same (a 24 hours period) period for delivering DV_{total} according to clause 6.2.10.

6.2.12 UE quality of service KPI

The final report shall include UE quality of service KPI as throughput. For every transmitted file an average throughput for that file shall be calculated. Average throughput of a file is calculated as file size divided by file transmission time. Transmission time starts when a UE requests a file and ends when the complete file is received.

For each traffic load level average UE throughput shall be reported for all UEs. 5th percentile shall also be provided, see Annex A.

7 Uncertainty

The measurement expanded uncertainty shall be assessed according to Annex D.

8 Measurement report

The results of the assessments shall be reported accurately, clearly, unambiguously and objectively and in accordance with any specific instructions in the required method(s).

A list of reference parameters, measurement conditions, test results, uncertainty analysis (see Annex D) and derived calculation results which shall be reported according to Annex A. The report shall contain a full list of equipment, interfaces and detailed test setup realized to perform the measurement in line with Figure 3.

Further guidelines on the test report can be found in clause 5.10 of ISO/IEC 17025 [i.3].

Annex A (normative): Test Reports

A.1 General information to be reported

Table A.1: Test general information

Items	Remarks
1) Test report reference and version	
2) Date of the test	
3) Standard Used as test methodology	
4) Location of the test	
5) Name of test organization and person responsible	
6) Tested equipment	
6.1) Tested HW unit names and serial numbers	
6.2) Software version of tested equipment	
7) List of used measurements equipment including type, serial number and calibration information	
8) List of used power saving features during the measurement	

Table A.2: BS reference parameters to be reported

Parameter	Value	Unit
1) BS configuration		
1.1) Number of sectors		
1.2) Nominal max RF output power per sector		W
1.3) Number of carriers per sector		
1.3.1) Number of carriers the BS is able to support		
1.3.2) Number of carriers, for which the HW was enabled (independent whether or not the carriers were used for the test)		
1.3.3) Number of carriers used during the test		
1.4) TX diversity		
1.5) RX diversity (number)		
1.6) Type of RF signal combining		
1.7) Remote Radio Head (Yes/No)		
2) Frequency		
2.1) Downlink band		MHz
2.2) Uplink band		MHz
2.3) Channel bandwidth		MHz
3) Environment		
3.1) Temperature range		°C
3.2) Type of air filter		
4) Features		
4.1) Power saving features		
4.2) Coverage and capacity features		
4.3) Downlink ciphering used? (Y/N)		
5) Propagation conditions		
5.1) Used fading model		

A.2 Base Station Energy Efficiency report

Table A.3: Measurements conditions and results to be reported for BS Energy Efficiency

Parameter	Test case 25 °C	Unit
1) Test environment		
1.1) Temperature during test (measured)		°C
1.2) Pressure (measured)		kPa
1.3) Relative humidity (measured)		%
2) Frequency used during test		
2.1) Downlink Centre frequency of middle channel		MHz
2.2) Uplink Centre frequency of middle channel		MHz
3) Supply voltage		
3.1) DC voltage (measured)		V
3.2) AC voltage (measured, phase to neutral)		V
3.3) AC Frequency (measured)		Hz
4) Weighting Factors		
4.1) W_{low}		hour
4.2) W_{medium}		hour
4.3) $W_{busy-hour}$		hour
5) Dynamic energy consumption (measured)		
4.1) Low traffic load level		kWh
4.2) Medium traffic load level		kWh
4.3) Busy-hour traffic load level		kWh
6) Accumulated measured data volume		
5.1) Low traffic load level		Mbits
5.2) Medium traffic load level		Mbits
5.3) Busy-hour traffic load level		Mbits
7) Test time		
6.1) Test time for low load scenario		s
6.2) Test time for medium load scenario		s
6.3) Test time for busy-hour load scenario		s
6.4) Idle time		s

Table A.4: Calculated results to be reported for BS Energy Efficiency

Parameter	Value	Unit
1) Total delivered data in Mbits during the test		Mbits
2) Total energy consumption		kWh
3) Base Station Energy Efficiency (BSEE)		Mbits/kWh
4) Average UE throughput		
4.1) Low traffic load level		kbits
4.2) Medium traffic load level		kbits
4.3) Busy-hour traffic load level		kbits
5) 5th percentile UE throughput		
5.1) Low traffic load level		kbits
5.2) Medium traffic load level		kbits
5.3) Busy-hour traffic load level		kbits
6) BSEE expanded uncertainty		%

The measurement report shall include the uncertainty table following the template defined in Table D.1.

Table A.5: UE Emulator reporting table

Item	Value	Remarks	Unit
Additional Antenna attenuator for DL test		Value of sensitivity and power correction attenuators as specified in section UE requirements	dB
Additional Antenna attenuator for UL test		Value of sensitivity and power correction attenuators as specified in section UE requirements	dB
UE Category	4	This category is fixed for purpose of testing	
UE emulator version			
UE Emulator Model			
UE Emulator Manufacturer			
Maximum specified DL data rate		According to manufacturer data sheet	kbps
Maximum specified UL data rate		According to manufacturer data sheet	kbps
Serial number			
UE emulator SW version			
Other		Any other information/parameter that is needed to reproduce the measurement shall be stated	

Annex B (normative): Reference parameters for LTE system

Reference configurations for LTE shall be:

- Only normal cyclic prefix is used.
- RF output power: 2 x 40 W.
- PBCH shall be transmitted.
- PDCCH REG EPRE and PDSCH PRB P_A shall be used as defined in TM1.1 [9].
- Usage of PDSCH PRBs and PSS & SSS & PBCH can overlap for medium load and busy hour load.
- PDCCH CCE allocation can be selected freely for medium load and busy hour load.
- Number of sectors and transmitters:
 - 111 (1 TX, 2 RX-paths per sector, SIMO);
 - 111 (1 carrier, 2 TX, 2 RX-paths per sector, MIMO).

RF bands are specified in ETSI TS 136 104 [5] The amount of available bandwidth varies for different frequencies. Table B.1 proposes the default bandwidth setting for different bands. Carrier bandwidth shall be chosen according to Table B.1.

Table B.1: Bandwidth and Duplex mode for different E-UTRA operating bands supported by current standard version

E-UTRA operating band	1	2	3	4	7	9	10	11	20	22	23	24	25	30	32
Duplex mode	FDD	FDD	FDD	FDD	FDD	FDD	FDD	FDD	FDD	FDD	FDD	FDD	FDD	FDD	FDD
Test BW (MHz)	20	20	20	20	20	20	20	20	20	20	20	20	20	20	20

- Power for RS: 15 dBm.
- RF output power level:
 - Power Range applicable to the "Wide Area BS" class as defined in ETSI TS 136 104 [5].
 - Maximum nominal RF output power at antenna connector according to product specification and according to the load levels (Output power at antenna connector = load model-based percentage * Maximum nominal RF output power) measured at the antenna connector according to ETSI TS 136 141 [9].
- Power Input:
 - -48 V DC, 230 V AC, 400 V DC.

Frequency bands for LTE:

The frequency band shall be as defined in ETSI TS 145 005 [13] and according to equipment specifications. For measurement centre frequency of the specified band is used.

Annex C (normative): Data Traffic Model

C.1 Data Traffic Model

The UEs shall be distributed based on the path loss distribution according to Table C.3 for low, medium and busy-hour traffic model.

Three file sizes are randomly requested by UEs. There is a waiting time randomly applied between each requested file by the UEs. These file sizes and waiting times and corresponding probabilities are defined in Table C.2.

The test time for each traffic load scenario is fixed and is specified in Table C.2. When the test time has ended, all the UEs disconnects and the BS enters an idle state. This idle state time (BS idle time) is also specified in Table C.2.

In addition to the path loss settings the minimum power received by the UE shall be specified (as it is in ETSI ES 202 706-1 [i.8]).

For the calculation of the BS energy efficiency, weighting factors based on a daily (24 hours) traffic load distribution profile consisting of the three measured traffic load levels; low load (low), medium load (med), and Busy Hour (BH) load are used. A mobile network operator is allowed to define a load distribution profile reflecting the situation in the network and mandate that profile to be used. Note that the selected load durations shall sum up to 24 hours. In case no load distribution profile has been defined, the default values defined in Table C.1 can be used. These weighting factors are denoted as W_{low} for low traffic load level, W_{medium} for medium traffic load level and $W_{busy-hour}$ for busy-hour traffic load level.

Table C.1: The Weighting factor

Traffic load level	Low	Medium	Busy-hour
Weighting Factor [hour]	$W_{low} = 6$	$W_{Medium} = 10$	$W_{busy-hour} = 8$

Table C.2: UE Traffic Model

UE traffic Model								
Metric	File size [KBytes]			Waiting Time [ms]			Test Time [min]	BS Idle Time [min]
Value	F_{small}	F_{medium}	F_{large}	WT_1	WT_2	WT_3	60	5
	0,28	30,5	665	14	310	8 000		
Probability	PF_{small}	PF_{medium}	PF_{large}	PT_1	PT_2	PT_3		
	77 %	22 %	1 %	64 %	35 %	1 %		

Table C.3: Test Scenarios

Test Scenarios			
Path-loss [dB]	85	110	130
Number of UEs in low Load	4	14	4
Number of UEs in medium Load	8	28	8
Number of UEs in busy-hour Load	17	66	17

C.2 Measured data for BS Energy Efficiency KPI calculation

To calculate the BS Energy Efficiency KPI, the equations specified in clause 6.2 shall be applied. Table C.4 lists the data needed for calculation of the BSEE KPI.

Table C.4: Data required for calculation of BSEE

Traffic load levels	Low	Medium	Busy-hour
Weighting factor [hour]	W_{low}	W_{medium}	$W_{busy-hour}$
Test time	$T_{test-low}$	$T_{test-medium}$	$T_{test-busy-hour}$
Measured data volume [Mbits]	$DV_{measured-low}$	$DV_{measured-medium}$	$DV_{measured-busy-hour}$
Measured Energy Consumption [kWh]	$E_{equipment}^{measured-traffic_scenario_low}$	$E_{equipment}^{measured-traffic_scenario_medium}$	$E_{equipment}^{measured-traffic_scenario_busy_hour}$

Annex D (normative): Uncertainty assessment

D.1 General requirements

The assessment of uncertainty in the measurement of the dynamic efficiency of a base station shall be based on the general rules provided by the IEC/ISO Guide 98-3 [12] "Evaluation of measurement data - Guide to the expression of uncertainty in measurement" that is publicly available at:

- http://www.bipm.org/utis/common/documents/jcgm/JCGM_100_2008_E.pdf.

Uncertainty factors are grouped into two categories according to the method used to estimate their numerical value:

- Type A: those which are evaluated by statistical means.
- Type B: those which are evaluated by other means, usually by scientific judgment using information available.

When a *Type A* analysis is performed, the standard uncertainty u_i shall be derived from the estimate from statistical observations.

When *Type B* analysis is performed, the standard uncertainty u_i is derived from the parameter $a = (a_+ - a_-)/2$, where a_+ is the upper limit and a_- is the lower limit of the measured quantity, and taking into account the distribution law of measured quantity, as follows:

- Normal law: $u_i = a/k$ where k is a coverage factor.
- U-shaped (asymmetric) law: $u_i = a/\sqrt{2}$.
- Rectangular law: $u_i = a/\sqrt{3}$ (default value to be used in the absence of any other information).
- Triangular law: $u_i = a/\sqrt{6}$ (not used in the present document).

D.2 Components contributing to uncertainty

D.2.1 Contribution of the measurement system

D.2.1.1 Uncertainty Tree description

The factors contributing to uncertainty are schematically shown in the uncertainty tree (Figure D.1).

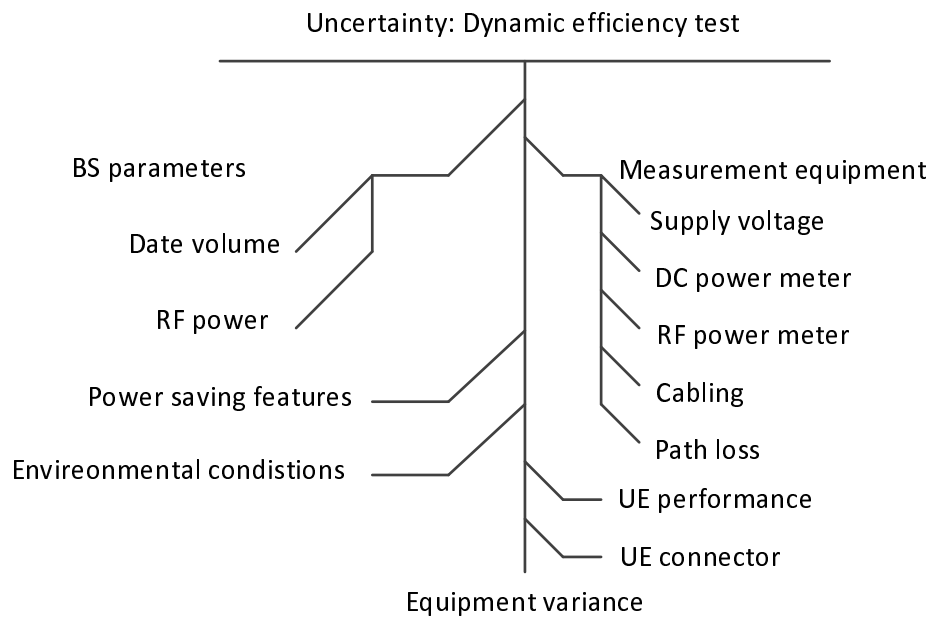

Figure D.1: Uncertainty tree - dynamic efficiency test

D.2.1.2 Measurement equipment

The uncertainty contributed by the measurement equipment, e.g. voltmeter, power meter, RF power meter shall be assessed with reference to its calibration certificates. The uncertainty due to the measurement device shall be evaluated assuming a type B normal probability distribution.

D.2.1.3 Attenuators, cables

The uncertainty contributed by the attenuator, shall be assessed with reference to its calibration certificates. The uncertainty due to the attenuator shall be evaluated assuming a Type B normal probability distribution.

D.2.1.4 UE emulator

The uncertainty contributed by the UE emulator, shall be assessed with reference to its calibration certificates. The uncertainty due to the UE emulator shall be evaluated assuming a Type B normal probability distribution.

D.2.1.5 Impact of environmental parameters

The impact of environmental parameters (mainly temperature) is assessed considering temperature variation during the measurement period. It has to be assured that the DUT has reached stable conditions as defined in clause 5.6. The uncertainty shall be evaluated assuming a Type B rectangular probability distribution.

D.2.1.6 Impact of path loss

The contribution due to the path loss, radio effects, etc. are controlled during the tests and the resulting error is less than $\pm x$ %. The uncertainty shall be evaluated assuming a Type B rectangular probability distribution. Path loss uncertainty is a result of attenuator and cable uncertainty as described under clause D.2.1.3.

D.2.1.7 Data volume

The uncertainty contributed by the traffic monitoring, shall be assessed with reference to its calibration certificates. The uncertainty due to the traffic monitoring shall be evaluated assuming a Type B normal probability distribution.

D.2.1.8 Variance of device under test

Based on component variances the individual base stations will have a certain deviation from the nominal value. The tested base station shall represent the nominal performance. The product to product efficiency spread is not considered in this uncertainty analysis but additional results on product efficiency spread might be provided.

D.3 Uncertainty assessment

D.3.1 Combined and expanded uncertainties

The contributions of each component of uncertainty shall be registered with their name, probability distribution, sensitivity coefficient and uncertainty value. The results shall be recorded in a table of the following formula. The combined uncertainty shall then be evaluated according to formula (D.1):

$$u_c = \sqrt{\sum_{i=1}^m c_i^2 \cdot u_i^2} \quad (\text{D.1})$$

where c_i is the weighting coefficient.

The expanded uncertainty shall be evaluated using a confidence interval of 95 % using the templates defined in Table D.1 for dynamic measurements.

Table D.1: Uncertainty analysis for dynamic efficiency assessment

ERROR SOURCES	Description (clause)	Uncertainty Value (%)	Probability Distribution	Divisor	c_i	Standard Uncertainty (%)
Measurement Equipment						
Supply voltage	D.2.1.1		Normal	1	1	
Power consumption / DC power meter	D.2.1.1		Normal	1	1	
RF power / RF power meter	D.2.1.1		Normal	1	1	
Cabling, Attenuators	D.2.1.3		Normal	1	1	
Data volume	D.2.1.7		Normal	1	1	
User equipment	D.2.1.4		Rectangular	$\sqrt{3}$	1	
Physical Parameters						
Environment conditions (T)	D.2.1.5	5 %	Rectangular	$\sqrt{3}$	0,5	
Impact of path loss	D.2.1.6		xx	xx	xx	
BS parameters						
Equipment variance	D.2.1.8	-	Gaussian			
Combined standard uncertainty			$u_c = \sqrt{\sum_{i=1}^m c_i^2 \cdot u_i^2}$			
Expanded uncertainty (confidence interval of 95 %)			Normal			$u_e = 1,96u_c$

D.3.2 Cross correlation of uncertainty factors

Cross correlations of above uncertainty factors are not considered if not otherwise stated.

D.3.3 Maximum expanded uncertainty

The expanded uncertainty with a confidence interval of 95 % shall not exceed 20 % for dynamic tests.

If the expanded uncertainty is exceeding this target, then the uncertainty shall be added to the measured results.

Annex E (informative): Bibliography

- NIST Technical Note 1297: "Guidance for evaluating and expressing the uncertainty of NIST measurement results".

History

Document history		
V1.1.1	August 2009	Publication as ETSI TS 102 706
V1.2.1	October 2011	Publication as ETSI TS 102 706
V1.3.1	July 2013	Publication as ETSI TS 102 706
V1.4.1	December 2014	Publication as ETSI ES 202 706
V1.5.1	November 2018	Publication
V1.6.1	February 2024	Publication
V1.7.1	July 2024	Publication