

ETSI TS 103 765-2 V1.1.1 (2026-01)



TECHNICAL SPECIFICATION

**Rail Telecommunications (RT);
Future Railway Mobile Communication System (FRMCS);
Building Blocks and Functions;
Part 2: Service Stratum**

Reference

DTS/RT-0084

Keywords

architecture, FRMCS, railways

ETSI

650 Route des Lucioles
F-06921 Sophia Antipolis Cedex - FRANCE

Tel.: +33 4 92 94 42 00 Fax: +33 4 93 65 47 16

Siret N° 348 623 562 00017 - APE 7112B
Association à but non lucratif enregistrée à la
Sous-Préfecture de Grasse (06) N° w061004871

Important notice

The present document can be downloaded from the
[ETSI Search & Browse Standards](#) application.

The present document may be made available in electronic versions and/or in print. The content of any electronic and/or print versions of the present document shall not be modified without the prior written authorization of ETSI. In case of any existing or perceived difference in contents between such versions and/or in print, the prevailing version of an ETSI deliverable is the one made publicly available in PDF format on [ETSI deliver](#) repository.

Users should be aware that the present document may be revised or have its status changed,
this information is available in the [Milestones listing](#).

If you find errors in the present document, please send your comments to
the relevant service listed under [Committee Support Staff](#).

If you find a security vulnerability in the present document, please report it through our
[Coordinated Vulnerability Disclosure \(CVD\)](#) program.

Notice of disclaimer & limitation of liability

The information provided in the present deliverable is directed solely to professionals who have the appropriate degree of experience to understand and interpret its content in accordance with generally accepted engineering or other professional standard and applicable regulations.

No recommendation as to products and services or vendors is made or should be implied.

No representation or warranty is made that this deliverable is technically accurate or sufficient or conforms to any law and/or governmental rule and/or regulation and further, no representation or warranty is made of merchantability or fitness for any particular purpose or against infringement of intellectual property rights.

In no event shall ETSI be held liable for loss of profits or any other incidental or consequential damages.

Any software contained in this deliverable is provided "AS IS" with no warranties, express or implied, including but not limited to, the warranties of merchantability, fitness for a particular purpose and non-infringement of intellectual property rights and ETSI shall not be held liable in any event for any damages whatsoever (including, without limitation, damages for loss of profits, business interruption, loss of information, or any other pecuniary loss) arising out of or related to the use of or inability to use the software.

Copyright Notification

No part may be reproduced or utilized in any form or by any means, electronic or mechanical, including photocopying and microfilm except as authorized by written permission of ETSI.

The content of the PDF version shall not be modified without the written authorization of ETSI.

The copyright and the foregoing restriction extend to reproduction in all media.

© ETSI 2026.
All rights reserved.

Contents

Intellectual Property Rights	5
Foreword.....	5
Modal verbs terminology.....	5
Introduction	6
1 Scope	7
2 References	7
2.1 Normative references	7
2.2 Informative references.....	8
3 Definition of terms, symbols and abbreviations.....	9
3.1 Terms.....	9
3.2 Symbols.....	9
3.3 Abbreviations	9
4 Architecture principles	10
4.1 General	10
4.2 Architecture.....	10
5 FRMCS Service Stratum constituents	11
5.1 Stand-alone FRMCS Service Domain.....	11
5.1.1 Functional entities.....	11
5.1.2 Reference points	12
5.1.3 Procedures.....	13
5.2 FRMCS Service Domain in interaction with other FRMCS Domains	13
5.2.1 Functional entities.....	13
5.2.2 Reference points	14
5.2.3 Procedures.....	15
5.3 FRMCS Domain in interaction with a GSM-R system	15
5.3.1 Functional entities.....	15
5.3.2 Reference points	15
5.3.3 Procedures.....	15
5.4 FRMCS interaction with non-FRMCS non-EIRENE System.....	15
6 FRMCS service procedures.....	15
6.1 MC User registration	15
6.1.1 MC User registration in Home FRMCS Service Domain.....	15
6.1.2 MC User registration in Foreign FRMCS Service Domain	16
6.2 FRMCS nominal operation procedures	17
6.2.1 MCPTT voice services.....	17
6.2.1.1 General	17
6.2.1.2 Call setup	17
6.2.1.3 Call rejoin, modify and determine participants	17
6.2.1.4 Location service	17
6.2.1.5 Emergency alert	17
6.2.1.6 Call release.....	18
6.2.2 MCDATA IP Connectivity	18
6.2.2.1 General	18
6.2.2.2 Basic mandatory procedures	19
6.2.2.2.1 MCDATA IPcon session establishment.....	19
6.2.2.2.2 MCDATA IPcon media plane.....	19
6.2.2.2.3 MCDATA IPcon session release	19
6.2.2.3 MCDATA IPcon session establishment	19
6.2.2.3.1 On-Board-FRMCS-originated MCDATA IPcon session establishment.....	19
6.2.2.3.2 FRMCS-Trackside-originated MCDATA IPcon session establishment	20
6.2.2.4 IP management and data transfer for H2H and H2N addressing schemes	21
6.2.2.4.1 IP layer model	21

6.2.2.4.2	IP management during an On-Board-FRMCS-originated Host-to-Host session establishment	21
6.2.2.4.3	IP management during an On-Board-FRMCS-originated Host-to-Network session establishment	24
6.2.2.4.4	IP management during a Trackside-Gateway-originated Host-to-Host session establishment	25
6.2.2.4.5	Data transfer from the On-Board-FRMCS to the FRMCS Trackside Gateway	26
6.2.2.4.6	Data transfer from the FRMCS Trackside Gateway to the On-Board-FRMCS	28
6.2.2.5	MCDATA IPcon session release	28
6.2.3	MCDATA SDS	28
6.2.4	MCDATA File Distribution	28
6.2.5	QoS and priority signalling.....	28
6.2.6	Functional aliasing.....	29
6.2.7	Arbitration.....	29
6.3	MC User deregistration	29
6.3.1	MC User deregistration in Home FRMCS Service Domain	29
6.3.2	MC User deregistration in Foreign FRMCS Service Domain	29
6.3.3	Network initiated MC User deregistration.....	29
6.4	Inter FRMCS service domain transition.....	30
6.4.1	MC Service User migration	30
6.4.2	Migrated MC Service user deauthorization	31
6.5	Communications encompassing multiple FRMCS Service Domains	32
6.5.1	MCPTT voice services in interconnected FRMCS service Domains	32
6.5.2	MCDATA IP Connectivity in interconnected FRMCS Service Domains.....	32
Annex A (informative):	Mapping table for Communication Session Category with User Requested Priority	33
History		34

Intellectual Property Rights

Essential patents

IPRs essential or potentially essential to normative deliverables may have been declared to ETSI. The declarations pertaining to these essential IPRs, if any, are publicly available for **ETSI members and non-members**, and can be found in ETSI SR 000 314: "*Intellectual Property Rights (IPRs); Essential, or potentially Essential, IPRs notified to ETSI in respect of ETSI standards*", which is available from the ETSI Secretariat. Latest updates are available on the [ETSI IPR online database](#).

Pursuant to the ETSI Directives including the ETSI IPR Policy, no investigation regarding the essentiality of IPRs, including IPR searches, has been carried out by ETSI. No guarantee can be given as to the existence of other IPRs not referenced in ETSI SR 000 314 (or the updates on the ETSI Web server) which are, or may be, or may become, essential to the present document.

Trademarks

The present document may include trademarks and/or tradenames which are asserted and/or registered by their owners. ETSI claims no ownership of these except for any which are indicated as being the property of ETSI, and conveys no right to use or reproduce any trademark and/or tradename. Mention of those trademarks in the present document does not constitute an endorsement by ETSI of products, services or organizations associated with those trademarks.

DECT™, **PLUGTESTS™**, **UMTS™** and the ETSI logo are trademarks of ETSI registered for the benefit of its Members. **3GPP™**, **LTE™** and **5G™** logo are trademarks of ETSI registered for the benefit of its Members and of the 3GPP Organizational Partners. **oneM2M™** logo is a trademark of ETSI registered for the benefit of its Members and of the oneM2M Partners. **GSM®** and the GSM logo are trademarks registered and owned by the GSM Association.

Foreword

This Technical Specification (TS) has been produced by ETSI Technical Committee Railway Telecommunications (RT).

The present document is part 2 of a multi-part deliverable covering Building Blocks and Functions for the Future Railway Mobile Communication System (FRMCS), as identified below:

- Part 1: "Transport Stratum";
- Part 2: "Service Stratum";**
- Part 3: "Train On-Board functions and interfaces";
- Part 4: "Trackside functions and interfaces";
- Part 5: "User Equipment (UE) capabilities".

Modal verbs terminology

In the present document "**shall**", "**shall not**", "**should**", "**should not**", "**may**", "**need not**", "**will**", "**will not**", "**can**" and "**cannot**" are to be interpreted as described in clause 3.2 of the [ETSI Drafting Rules](#) (Verbal forms for the expression of provisions).

"**must**" and "**must not**" are **NOT** allowed in ETSI deliverables except when used in direct citation.

Introduction

As the needs of the railway sector continue to evolve, ongoing digitalisation presents the appropriate response. In 2012, UIC initiated efforts to develop the Future Railway Mobile Communication System (FRMCS) - a modern replacement for GSM-R, which is expected to become obsolete in the early 2030s. This UIC project resulted in the creation of the FRMCS Functional Requirements Specification (FRS) and the FRMCS System Requirements Specification (SRS), both of which focus primarily on the communication needs of railways and serve as the foundation for developing the GSM-R successor.

The present document defines the building blocks and functions of the FRMCS Service Stratum, detailing how these components interact i.e. interfaces and procedures, and provide FRMCS services to users and groups of users using them for communicating amongst each other.

1 Scope

The present document defines the Service Stratum for the Future Railway Mobile Communications System (FRMCS). In general, the FRMCS Service Stratum provides communication service and corresponding complementary service resulting from 3GPP Mission Critical Services (MCX) and 3GPP multimedia system.

While FRMCS is defined in various FRMCS ETSI Technical Specifications, the present document determines necessary components of the FRMCS Service Stratum, encompassing:

- Building blocks and corresponding reference points of 3GPP MCX/IMS.
- Reference points between MC systems/IMS for interconnection and unilateral use by MC organizations (MC migration).
- Reference points between the MC system/IMS and external systems.
- QoS and priority management.
- User identification, authentication and authorization for the use of the FRMCS service stratum.
- Communication security aspects.
- Complementary and auxiliary service, e.g. alternative user addressing schemes.

2 References

2.1 Normative references

References are either specific (identified by date of publication and/or edition number or version number) or non-specific. For specific references, only the cited version applies. For non-specific references, the latest version of the referenced document (including any amendments) applies.

Referenced documents which are not found to be publicly available in the expected location might be found in the [ETSI docbox](#).

NOTE: While any hyperlinks included in this clause were valid at the time of publication, ETSI cannot guarantee their long-term validity.

The following referenced documents are necessary for the application of the present document.

- [1] [ETSI TS 123 228 \(V18.9.0\)](#): "Digital cellular telecommunications system (Phase 2+) (GSM); Universal Mobile Telecommunications System (UMTS); LTE; 5G; IP Multimedia Subsystem (IMS); Stage 2 (3GPP TS 23.228 version 18.9.0 Release 18)".
- [2] [ETSI TS 123 280 \(V18.12.0\)](#): "LTE; Common functional architecture to support mission critical services; Stage 2 (3GPP TS 23.280 version 18.12.0 Release 18)".
- [3] [ETSI TS 124 482 \(V18.0.1\)](#): "LTE; Mission Critical Services (MCS) identity management; Protocol specification (3GPP TS 24.482 version 18.0.1 Release 18)".
- [4] [ETSI TS 124 484 \(V18.7.0\)](#): "LTE; Mission Critical Services (MCS) configuration management; Protocol specification (3GPP TS 24.484 version 18.7.0 Release 18)".
- [5] [ETSI TS 133 180 \(V18.1.0\)](#): "LTE; Security of the Mission Critical (MC) service (3GPP TS 33.180 version 18.1.0 Release 18)".
- [6] [ETSI TS 123 379 \(V18.12.0\)](#): "LTE; Functional architecture and information flows to support Mission Critical Push To Talk (MCPTT); Stage 2 (3GPP TS 23.379 version 18.12.0 Release 18)".
- [7] [ETSI TS 124 379 \(V18.10.0\)](#): "LTE; Mission Critical Push To Talk (MCPTT) call control; Protocol specification (3GPP TS 24.379 version 18.10.0 Release 18)".

- [8] [ETSI TS 123 282 \(V18.10.0\)](#): "LTE; Functional architecture and information flows to support Mission Critical Data (MCData); Stage 2 (3GPP TS 23.282 version 18.10.0 Release 18)".
- [9] [ETSI TS 124 282 \(V18.10.0\)](#): "LTE; Mission Critical Data (MCData) signalling control; Protocol specification (3GPP TS 24.282 version 18.10.0 Release 18)".
- [10] [ETSI TS 124 582 \(V18.2.0\)](#): "LTE; Mission Critical Data (MCData) media plane control; Protocol specification (3GPP TS 24.582 version 18.2.0 Release 18)".
- [11] [ETSI TS 123 281 \(V18.9.0\)](#): "LTE; Functional architecture and information flows to support Mission Critical Video (MCVideo); Stage 2 (3GPP TS 23.281 version 18.9.0 Release 18)".
- [12] [ETSI TS 123 002 \(V18.0.0\)](#): "Digital cellular telecommunications system (Phase 2+) (GSM); Universal Mobile Telecommunications System (UMTS); LTE; Network architecture (3GPP TS 23.002 version 18.0.0 Release 18)".
- [13] [ETSI TS 124 229 \(V18.7.0\)](#): "Digital cellular telecommunications system (Phase 2+) (GSM); Universal Mobile Telecommunications System (UMTS); LTE; 5G; IP multimedia call control protocol based on Session Initiation Protocol (SIP) and Session Description Protocol (SDP); Stage 3 (3GPP TS 24.229 version 18.7.0 Release 18)".
- [14] [ETSI TS 133 203 \(V18.1.0\)](#): "Digital cellular telecommunications system (Phase 2+) (GSM); Universal Mobile Telecommunications System (UMTS); LTE; 3G security; Access security for IP-based services (3GPP TS 33.203 version 18.1.0 Release 18)".
- [15] [ETSI TS 103 765-1](#): "Rail Telecommunications (RT); Future Railway Mobile Communication System (FRMCS); Building Blocks and Functions; Part 1: Transport Stratum".
- [16] [ETSI TS 103 792](#): "Rail Telecommunications (RT); Future Railway Mobile Communication System (FRMCS); Interworking with GSM-R".
- [17] [UIC FIS-7970](#): "Future Railway Mobile Communication System; Functional Interface Specification", Version 2.1.0.
- [18] [ETSI TS 123 283 \(V18.2.0\)](#): "LTE; Mission Critical Communication Interworking with Land Mobile Radio Systems (3GPP TS 23.283 version 18.2.0 Release 18)".
- [19] [ETSI TS 123 203 \(V18.0.0\)](#): "Digital cellular telecommunications system (Phase 2+) (GSM); Universal Mobile Telecommunications System (UMTS); LTE; Policy and charging control architecture (3GPP TS 23.203 version 18.0.0 Release 18)".
- [20] [ETSI TS 123 503 \(V18.9.0\)](#): "5G; Policy and charging control framework for the 5G System (5GS); Stage 2 (3GPP TS 23.503 version 18.9.0 Release 18)".

2.2 Informative references

References are either specific (identified by date of publication and/or edition number or version number) or non-specific. For specific references, only the cited version applies. For non-specific references, the latest version of the referenced document (including any amendments) applies.

NOTE: While any hyperlinks included in this clause were valid at the time of publication, ETSI cannot guarantee their long-term validity.

The following referenced documents may be useful in implementing an ETSI deliverable or add to the reader's understanding, but are not required for conformance to the present document.

- [i.1] ETSI TR 103 791: "Rail Telecommunications (RT); Future Railway Mobile Communication System (FRMCS); Terminology for FRMCS specifications".
- [i.2] ETSI TS 103 764: "Rail Telecommunications (RT); Future Railway Mobile Communication System (FRMCS); System Architecture".

- [i.3] ETSI TS 103 765-3: "Rail Telecommunications (RT); Future Railway Mobile Communication System (FRMCS); Building Blocks and Functions; Part 3: Train On-Board functions and interfaces".
- [i.4] ETSI TS 103 765-4: "Rail Telecommunications (RT); Future Railway Mobile Communication System (FRMCS); Building Blocks and Functions; Part 4: Trackside functions and interfaces".

3 Definition of terms, symbols and abbreviations

3.1 Terms

For the purposes of the present document, the terms given in ETSI TR 103 791 [i.1] and the following apply:

FRMCS SIP Core: Set of entities either:

- compliant with ETSI TS 123 228 [1] (3GPP IP multimedia core network subsystem);
- or supporting the reference points identified in ETSI TS 123 280 [2], clause 7.5.3 compliant with the reference points defined in ETSI TS 123 002 [12].

3.2 Symbols

Void.

3.3 Abbreviations

For the purposes of the present document, the following abbreviations apply:

3GPP	3G Partnership Project
5GC	5G Core
AKA	Authentication and Key Agreement
API	Application Programming Interface
APP	Application
AS	Application Server
ATO	Automatic Train Operation
ATP	Automatic Train Protection
CSC	Common Service Core
DNS	Domain Name Service
FIS	Functional Requirement Specification (UIC)
FQDN	Fully Qualified Domain Name
FRMCS	Future Railway Mobile Communication System
FROP	FRMCS On-Board Profile
FRS	Functional Requirement Specification (UIC)
FS _{IWF}	FRMCS InterWorking Function
FS _{NNI}	FRMCS Network-to-Network Interface
FS _{ONI}	FRMCS Other Network Interface
GRE	Generic Routing Encapsulation
GSM-R	Global System for Mobile communications - Railways
H2H	Host-to-Host
H2N	Host-to-Network
HTTP	Hyper Text Transfer Protocol
IBCF	Interconnect Border Control Function
IdM	Identity Management
IMS	IP Multimedia Subsystem
IP	Internet Protocol
IPcon	IP connectivity
IWF	InterWorking Function
LC	Loose-Coupled (Application)

MC	Mission-Critical
MCPTT	Mission-Critical Push-To-Talk
MCX	Mission Critical Service
MFCN	Mobile Fixed Communication Network
NAT	Network Address Translation
NDS	Network Domain Security
NEF	Network Exposure Function
NNI	Network-to-Network Interface
OB	On-Board FRMCS
ONI	Other Network Interface

NOTE: ONI only gets used as part of FSONI, which is in the list already.

PCF	Policy Control Function
PLMN	Public Land Mobile Network
QoS	Quality of Service
SAP	Service Access Point
SCTP	Stream Control Transmission Protocol
SDS	(MCData) Short Data Service
SIP	Session Initiation Protocol
SLC	Super-Loose Coupled
SRS	System Requirement Specification (UIC)
TAP	Transport Access Point
TCMS	Train Control and Management System
TLS	Transport Layer Security
TrGW	Transition GateWay
TS	TrackSide
UDP	User Datagram Protocol
UE	User Equipment
URI	Uniform Resource Identifier

4 Architecture principles

4.1 General

Clause 4 describes system architecture of the Service Stratum to support communication services and complementary services for FRMCS. The system architecture is applicable for FRMCS using 3GPP Mission Critical Services (MCX) and the related MCX architecture defined in ETSI TS 123 280 [2], ETSI TS 123 379 [6], ETSI TS 123 281 [11] and ETSI TS 123 282 [8] from 3GPP Release 18 onwards.

4.2 Architecture

The system architecture of the FRMCS service stratum is illustrated in Figure 4.2-1.

The FRMCS service stratum may consist of different domains, independent of the geographical allocation, and follows the Service Client - Server approach (Figure 4.2-1) applicable in on-network operation mode.

The necessary interconnection between the different FRMCS service domains enables the service stratum users to communicate between them using SAP interconnection via FS_{NNI} reference point.

For communication with legacy railway communication systems, i.e. GSM-R, the FRMCS Service Stratum enables the necessary interworking using SAP Legacy Systems via FS_{IWF} reference point (Figure 4.2-1) for this purpose.

For the communication with external systems, e.g. MFCN, the FRMCS Service Stratum enables the necessary interconnection/interworking using the SAP External Systems via FS_{ONI} reference point (Figure 4.2-1).

For the transmission of the communications between Service Client and Service Server encompassing signalling and user data, the FRMCS service stratum (Figure 4.2-1) uses unicast transmission paths of the FRMCS transport stratum using the TAPs in accordance with ETSI TS 103 765-1 [15].

The components of the various SAPs are described in more detail in the following clauses.

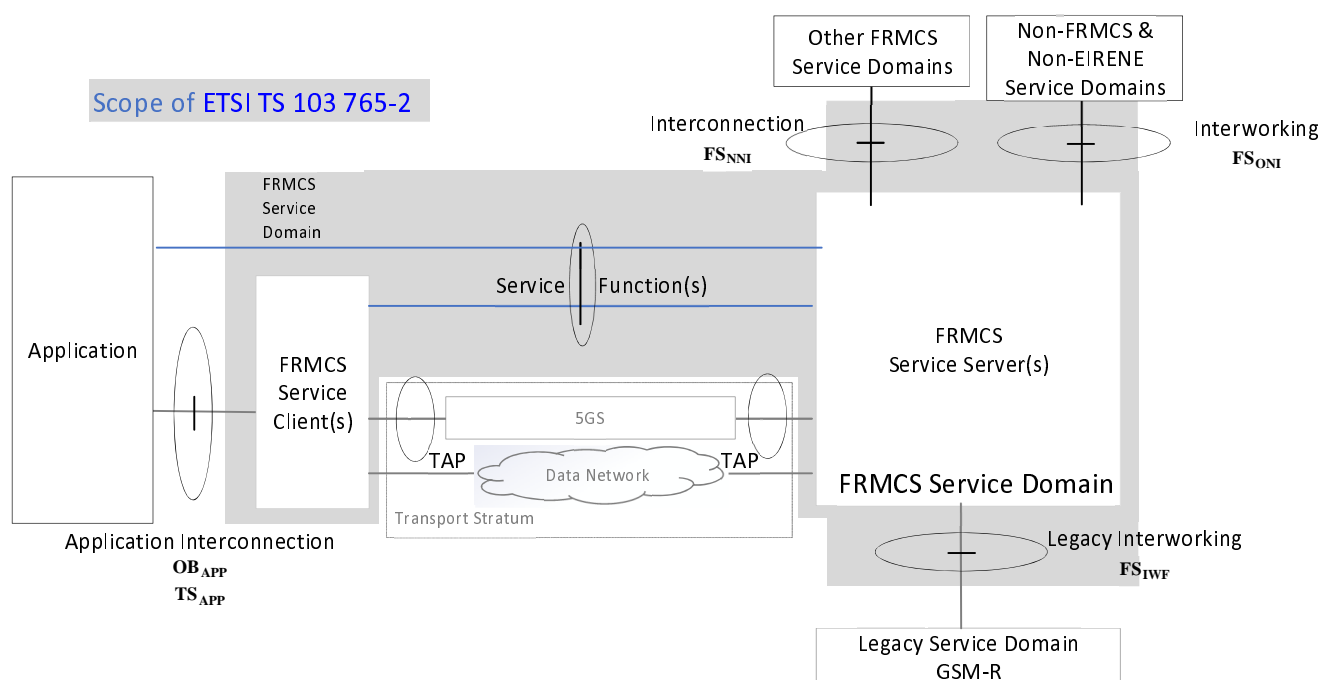

Figure 4.2-1: FRMCS Service Stratum - system architecture

5 FRMCS Service Stratum constituents

5.1 Stand-alone FRMCS Service Domain

5.1.1 Functional entities

The signalling control functions of the FRMCS Service Stratum shall comply with ETSI TS 123 280 [2].

The FRMCS Service Domain shall support the following functional server entities as described in ETSI TS 123 280 [2], clause 7.4.2.2:

- Configuration management server.
- Identity management server.
- Key management server.
- Location management server.
- Functional alias management server.

The FRMCS Service Domain shall support the following functional server entities for the MCPTT service (limited to MCPTT ad hoc group call and emergency alert realized through MCPTT ad hoc group call):

- MCPTT server as described in ETSI TS 123 379 [6], clause 7.4.2.3.2.
- Floor control server as described in ETSI TS 123 379 [6], clause 7.4.2.3.4.
- Media distribution function as described in ETSI TS 123 379 [6], clause 7.4.2.3.5.
- MCPTT user database as described in ETSI TS 123 379 [6], clause 7.4.2.3.7.

The FRMCS Service Domain shall support the following functional server entities for the MCDData service (limited to MCDData IPCon and MCDData SDS):

- MCDData server as described in ETSI TS 123 282 [8], clause 6.4.3.1.2.
- MCDData user database as described in ETSI TS 123 282 [8], clause 6.4.3.1.3.
- MCDData notification server as described in ETSI TS 123 282 [8], clause 6.4.3.5.

5.1.2 Reference points

The FRMCS Service Domain shall support the following reference points between Service Client and Service Server:

- reference points for IMS/SIP and HTTP signalling as listed in Table 5.1.2-1;
- reference points for Common service core as listed in Table 5.1.2-2;
- reference points for MCPTT as listed in Table 5.1.2-3; and
- reference points for MCDData (SDS, IPcon) as listed in Table 5.1.2-4.

Table 5.1.2-1: Reference Points of a stand-alone FRMCS Service Domain for IMS/SIP and HTTP Signalling

MCx Reference Point	Endpoints	Underlying MCx signalling/control plane	ETSI Reference
SIP-1	SIP Signalling user agent - FRMCS SIP Core	Gm	ETSI TS 123 002 [12]
SIP-2	FRMCS SIP Core - Application Server (AS)	ISC and Ma	ETSI TS 123 002 [12]
HTTP-1	HTTP client - HTTP proxy	Ut	ETSI TS 123 002 [12]
HTTP-2	HTTP proxy - HTTP server	HTTP	ETSI TS 123 280 [2]
AAA-1	SIP database - FRMCS SIP core	Cx	ETSI TS 123 002 [12]
AAA-2	FRMCS SIP core - Diameter proxy	Cx	ETSI TS 123 002 [12]

Table 5.1.2-2: Reference Points of a stand-alone FRMCS Service Domain for Common Service Core

MCx Reference Point	Endpoints	Underlying MCx signalling/control plane	ETSI Reference
CSC-1	Identity management Client - Identity management Server	HTTPS (TLS)	ETSI TS 133 180 [5]
CSC-4	Configuration management Client - Configuration management Server	HTTP-1 and HTTP-2 SIP-1 and SIP-2	ETSI TS 123 280 [2]
CSC-5	Configuration management Server - MC service server	HTTP-1 and HTTP-2, SIP-2	ETSI TS 123 280 [2]
CSC-8	Key management Client - Key management Server	HTTP-1 and HTTP-2	ETSI TS 123 280 [2]
CSC-9	Key management Server - MC service server	HTTP-1 and HTTP-2	ETSI TS 123 280 [2]
CSC-10	Key management Server - Group management Server	HTTP-1, HTTP-2 (and may use HTTP-3)	ETSI TS 123 280 [2]
CSC-13	Configuration management Server - MC service user database		ETSI TS 123 280 [2]
CSC-14	Location management Client - Location management Server	SIP-1 and SIP-2, HTTP-1 and HTTP-2	ETSI TS 123 280 [2]
CSC-15	Location management Server - MC service server	SIP-1 and SIP-2, HTTP-1 and HTTP-2	ETSI TS 123 280 [2]

Table 5.1.2-3: Reference Points of a stand-alone FRMCS Service Domain for MCPTT

MCx Reference Point	Endpoints	Underlying MCx signalling/control plane	ETSI Reference
MCPTT-1	MCPTT Server - MCPTT Client (via SIP/IMS Core)	SIP-1, SIP-2, HTTP-1, HTTP-2	ETSI TS 123 379 [6]
MCPTT-2	MCPTT Server - MCPTT User database	AAA-1	ETSI TS 123 379 [6]
MCPTT-4	Floor control server - Floor participant	SGi	ETSI TS 123 379 [6] ETSI TS 123 002 [12]
MCPTT-5	MCPTT Server - 5GC	N5/Rx (via PCF for trusted domain) N33 (via NEF for un-trusted domain)	ETSI TS 123 379 [6] ETSI TS 123 203 [19] ETSI TS 123 503 [20]
MCPTT-7	Media distribution function - Media mixer	SGi	ETSI TS 123 379 [6] ETSI TS 123 002 [12]

Table 5.1.2-4: Reference Points of a stand-alone FRMCS Service Domain for MCDData (SDS and IPcon)

MCx Reference Point	Endpoints	Underlying MCx signalling/control plane	ETSI Reference
MCDData-2	MCDData server - MCDData user database	SCTP based Diameter management application protocol	ETSI TS 123 282 [8] ETSI TS 123 283 [18]
MCDData-5	MCDData server - 5GC	N5/Rx (via PCF for trusted domain) N33 (via NEF for un-trusted domain)	ETSI TS 123 282 [8] ETSI TS 123 203 [19] ETSI TS 123 503 [20]
MCDData-10	Message notification client - MCDData notification server		ETSI TS 123 282 [8]
MCDData-SDS-1	MCDData Server - MCDData Client	SIP-1 SIP-2	ETSI TS 123 282 [8]
MCDData-SDS-2	SDS distribution function - SDS function (unicast)	SGi	ETSI TS 123 282 [8] ETSI TS 123 002 [12]
MCDData-IPcon-1	MCDData Server - MCDData Client	SIP-1 SIP-2	ETSI TS 123 282 [8]
MCDData-IPcon-2	U-IPcon distribution function - U-IPcon function (unicast)		ETSI TS 123 282 [8]

NOTE: Interface AAA-1 may not be exposed as described in ETSI TS 123 280 [2], clause 9.2.2.2, note 1.

5.1.3 Procedures

The FRMCS Service Domain shall support the functionalities required for the following procedures of clause 6:

- MC User registration in Home FRMCS Service Domain.
- MC User deregistration in Home FRMCS Service Domain.
- FRMCS nominal operation procedures.

5.2 FRMCS Service Domain in interaction with other FRMCS Domains

5.2.1 Functional entities

To provide the necessary signalling and voice codec adaptation for interworking with external networks, the FRMCS Service Domain shall support the following functions of the IP Multimedia Core Network Subsystem defined in ETSI TS 123 228 [1]:

- IBCF and TrGW for interworking with public wireless systems, such as PLMN or other FRMCS service domains as described in ETSI TS 124 229 [13].

The FRMCS Service Domain shall support the following functional server entities for the MCPTT service:

- MC gateway server as described in ETSI TS 123 379 [6], clause 7.4.2.3.8.

The FRMCS Service Domain shall support the following functional server entities for the MCDATA service:

- MC gateway server as described in ETSI TS 123 282 [8], clause 6.4.3.1.5.

5.2.2 Reference points

This clause specifies the reference points between two FRMCS service domains.

FS_{NNI} provides the following functionalities to comply with SAP Interconnection:

- Support of inter-FRMCS service domain application and control plane signalling (SIP and HTTP signalling).
- Communication services between MC Service Users served by different FRMCS Service Domains.
- Topology hiding support.
- Inter-FRMCS service domain out of band sharing (certificate exchange between FRMCS service domains).
- Inter-FRMCS service domain interconnection security.

NOTE: Out of band sharing mechanism is not specified in the present document and subject to agreement between FRMCS operators.

The FRMCS Service Domain shall support the following reference points which constitute FS_{NNI} at the Service Stratum for the MC application plane and MC signalling control plane:

- MCX-1 as specified in ETSI TS 123 280 [2], clause 7.5.2.19.
- CSC-17 as specified in ETSI TS 123 280 [2], clause 7.5.2.17.
- CSC-20 as specified in ETSI TS 123 280 [2], clause 7.5.2.21.
- CSC-21 as specified in ETSI TS 123 280 [2], clause 7.5.2.22.
- CSC-22 as specified in ETSI TS 123 280 [2], clause 7.5.2.23.
- CSC-23 as specified in ETSI TS 123 280 [2], clause 7.5.2.24.
- CSC-24 as specified in ETSI TS 123 280 [2], clause 7.5.2.25.
- SIP-3 as specified in ETSI TS 123 280 [2], clause 7.5.3.4.
- HTTP-3 as specified in ETSI TS 123 280 [2], clause 7.5.3.7.
- AAA-2 as specified in ETSI TS 123 280 [2], clause 7.5.3.9.

The FRMCS Service Domain shall support the following reference points which constitute FS_{NNI} at the Service Stratum for the MCPTT service:

- MCPTT-3 as specified in ETSI TS 123 379 [6], clause 7.5.2.4.
- MCPTT-10 as specified in ETSI TS 123 379 [6], clause 7.5.2.13.

The FRMCS Service Domain shall support the following reference points which constitute FS_{NNI} at the Service Stratum for the MCDATA service:

- MCDATA-3 as specified in ETSI TS 123 282 [8], clause 6.4.4.1.3.
- MCDATA-9 as specified in ETSI TS 123 282 [8], clause 6.4.4.1.8.
- MCDATA-10 as specified in ETSI TS 123 282 [8], clause 6.4.4.1.9.

5.2.3 Procedures

The FRMCS Service Domain shall support the functionalities required for the following procedures of clause 6:

- MC User registration in Foreign FRMCS Service Domain.
- MC User deregistration in Foreign FRMCS Service Domain.
- Inter FRMCS service domain transition.
- Communications encompassing multiple FRMCS Service Domains.

5.3 FRMCS Domain in interaction with a GSM-R system

5.3.1 Functional entities

No additional functional entities are required for a FRMCS Service Domain in interaction with a GSM-R system.

5.3.2 Reference points

The FRMCS Service Domain shall support the following reference points as specified ETSI TS 103 792 [16], clause 5.2:

- IWF-1.
- IWF-2.
- IWF-3.

5.3.3 Procedures

No additional procedures are required for a FRMCS Service Domain in interaction with a GSM-R system.

5.4 FRMCS interaction with non-FRMCS non-EIRENE System

The present document does not specify normative requirements applicable to interaction of FRMCS with non-FRMCS non-EIRENE System.

6 FRMCS service procedures

6.1 MC User registration

6.1.1 MC User registration in Home FRMCS Service Domain

This clause describes the MC User registration procedure in Home FRMCS Service Domain.

The values passed into this procedure by its caller entity (e.g. On-Board FRMCS in ETSI TS 103 765-3 [i.3] or FRMCS Trackside Gateway in ETSI TS 103 765-4 [i.4]) shall be used by the IdM Client and individual MC Service clients involved in the procedures referenced below. These values are MC User ID and its associated password, scope and IMS/SIP credential.

The MC User registration procedure in Home FRMCS Service Domain is constituted of the following steps:

Step 1 - Bootstrap of MC default/initial configurations

The MC procedures for the configuration of MCS UE initial configuration Management Object and the default MCS user profile configuration Management Object(s) shall conform to ETSI TS 124 484 [4], clause 4.2.2 for the online configuration case.

NOTE: The URIs of Configuration Management Server and the Identity Management Server are retrieved from FROP.

Step 2 - MC User authentication and MC token acquiring

The IdM Client procedures for user authentication in primary MC system shall conform to ETSI TS 124 482 [3], clause 6.2.1.

The IdM Server procedures for user authentication in primary MC system shall conform to ETSI TS 124 482 [3], clause 6.3.1.

Step 3 - Configuration of MC service user profile and MC service group

The MC procedures for subscribing to the MCS UE configuration document, the MCS user profile configuration document and the MCS service configuration document for each enabled MC Service shall conform to ETSI TS 124 484 [4], clause 4.2.2 for the online configuration case.

Step 4 - SIP registration

The signalling user agent shall establish a secure connection to the SIP core for the purpose of SIP authentication and registration and subsequently perform the SIP level registration as per ETSI TS 133 180 [5], clause 5.1.1, step B-1.

Step 5 - MC Service User authorization per MC Service in the scope

All MC clients scoped for the authenticated MC User ID in step 2 shall perform the MC service authorization sending the access token to the MC server using SIP PUBLISH message as per ETSI TS 133 180 [5], clause 5.1.3.2.3.

SIP Digest shall be used as security mechanism with for MC clients of tight coupled and loose coupled applications. SIP Digest shall be used for FRMCS SIP Core access authentication over non-3GPP access including NDS/IP as per Annex N (SIP Digest without TLS) and Annex O (SIP Digest with TLS) of ETSI TS 133 203 [14]. IMS AKA as specified in ETSI TS 133 203 [14] should be limited to FRMCS Handhelds.

6.1.2 MC User registration in Foreign FRMCS Service Domain

This clause describes the MC User registration in Foreign FRMCS Service Domain.

The values passed into this procedure by its caller entity (i.e. On-Board FRMCS in ETSI TS 103 765-3 [i.3]) shall be used by the IdM Client and individual MC Service clients involved in the procedures referenced below. These values are MC User ID and its associated password, scope and the IMS/SIP credentials in the Home FRMCS Service Domain and in the Foreign FRMCS Service Domain.

The MC User registration procedure in Foreign FRMCS Service Domain for a MC user associated to interoperable applications is constituted of the following steps:

Step 1 - MC User authentication in primary MC system and selection of user profile to permit migration to the selected partner MC system

If this has not been executed previously, the steps 1 to 3 in clause 6.1.1 shall be performed. In this step, the MC client obtains the MC service user profile from the primary MC system to permit migration to the selected partner MC system (each user profile received from the primary MC system contains a list of partner MC systems to which migration is permitted using that user profile, together with their access information).

NOTE 1: The "selected partner MC system" is the one which is associated to the Foreign FRMCS Service Domain.

Step 2 - The MC User migration procedure as defined in clause 6.4.1 shall be performed on the authenticated MC User in Step 1

MC users associated with non-interoperable applications of Type IV cannot be permitted to migrate to the partner MC system. MC user authentication and corresponding MC service user authorization for each MC service associated with non-interoperable applications shall be as described in clause 6.1.1.

NOTE 2: The transport path to the home FRMCS Service Domain is as described in ETSI TS 103 765-1 [15].

6.2 FRMCS nominal operation procedures

6.2.1 MCPTT voice services

6.2.1.1 General

The FRMCS Service Domain shall support ETSI TS 123 379 [6], clause 10.19.3.1 for MCPTT ad hoc group call procedures using "on-demand" Session.

The FRMCS Service Domain shall support for the ad hoc group call criteria the comma-separated list as specified in UIC FRMCS FIS-7970 [17], clause 4.3.6.10.3 with values as specified in UIC FRMCS FIS-7970 [17], clause 4.3.6.10.4, Table 2 and clause 4.4.6.1.4, Table 4.

NOTE: The present document does not specify any normative requirements related to MCPTT private call, in particular related to ETSI TS 103 792 [16], clause 8.

6.2.1.2 Call setup

The FRMCS Service Domain shall support ETSI TS 124 379 [7], clauses 17.3.2.1 and 17.4.2 for MCPTT ad hoc group call setup.

6.2.1.3 Call rejoin, modify and determine participants

The FRMCS Service Domain shall support ETSI TS 124 379 [7], clauses 17.3.4.1 and 17.4.4.1 for MCPTT ad hoc group call rejoin.

The FRMCS Service Domain shall support ETSI TS 124 379 [7], clauses 17.3.5.1 and 17.4.5.1 for MCPTT ad hoc group call modification of the participant list or criteria for the participant list.

The FRMCS Service Domain shall support ETSI TS 124 379 [7], clauses 17.3.6 and 17.4.6 for MCPTT ad hoc group call participants determination.

6.2.1.4 Location service

The FRMCS Service Domain shall support ETSI TS 124 379 [7], clause 13.2.2 for MCPTT ad hoc group call location reporting configuration.

The FRMCS Service Domain shall support ETSI TS 124 379 [7], clause 13.2.3 for MCPTT ad hoc group call location information request.

The FRMCS Service Domain shall support ETSI TS 124 379 [7], clause 13.2.4 for MCPTT ad hoc group call location information report.

6.2.1.5 Emergency alert

The FRMCS Service Domain shall support ETSI TS 124 379 [7], clauses 6.3.3.1.13.8 and 6.3.3.1.13.9 for initiating and cancelling an MCPTT ad hoc group emergency alert.

The FRMCS Service Domain shall support ETSI TS 124 379 [7], clause 6.3.3.1.13.10 for determining MCPTT users that are authorized for receiving MCPTT ad hoc group emergency alert participant information.

The FRMCS Service Domain shall support ETSI TS 124 379 [7], clause 6.3.3.1.23 to populate mcptt-info MIME bodies for ad hoc group emergency alert.

The FRMCS Service Domain shall support ETSI TS 124 379 [7], clause 6.3.3.1.24 for generating a SIP MESSAGE request to containing the participant lists of an MCPTT ad hoc group emergency alert.

The FRMCS Service Domain shall support ETSI TS 124 379 [7], clause 6.3.3.1.25 to validate ad hoc group priority request parameters.

The FRMCS Service Domain shall support ETSI TS 124 379 [7], clauses 12.1A2 and 12.1A3 for MCPTT ad hoc group emergency alert.

6.2.1.6 Call release

The FRMCS Service Domain shall support ETSI TS 124 379 [7], clauses 17.3.3.1 and 17.4.3 for MCPTT ad hoc group call release.

6.2.2 MCDATA IP Connectivity

6.2.2.1 General

MCDATA IPCon is used to provide transparent IP connection between FRMCS Service Clients acting as MCDATA IPCon clients as per ETSI TS 124 282 [9] and ETSI TS 124 582 [10].

The transparent IP data connection is achieved by using an GRE over UDP Tunnelling of the application layer IP flow.

Two different connectivity models are defined within FRMCS:

- Host-to-Host Connectivity Model (H2H), providing a transparent IP connection between two host entities each with a defined IP address.
- Host-to-Network Connectivity Model (H2N), providing a transparent IP connection between a single host entity (defined via an IP address) and an IP network where multiple hosts can be connected.

Figure 6.2.2.1-1 depicts the service layer model for both Host-to-Host and Host-to-Network connectivity.

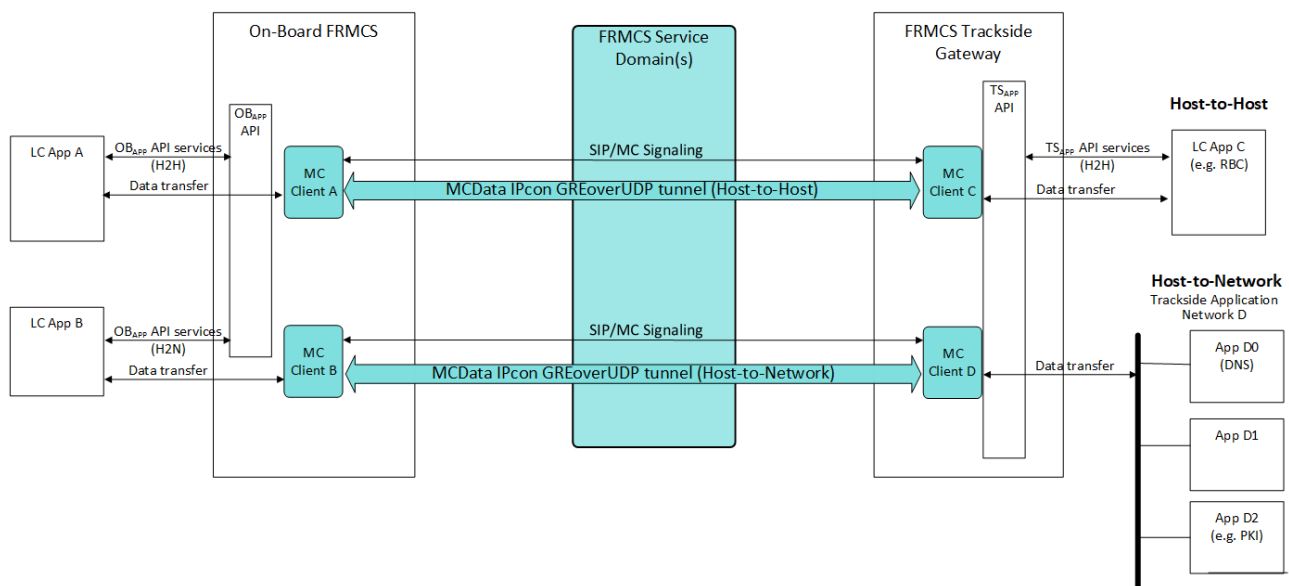

NOTE: The relevant OBAPP/TSAPP API services (open session, incoming session, etc.) depend on whether the On-Board-FRMCS/FRMCS-Trackside-Gateway is acting as originator or terminator of the end-to-end (reference ETSI TS 103 765-3 [i.3] for On-Board FRMCS and to ETSI TS 103 765-4 [i.4] for FRMCS Trackside Gateway).

Figure 6.2.2.1-1: Service Layer model of Host-to-Host (H2H) and Host-to-Network (H2N) connectivity

6.2.2.2 Basic mandatory procedures

6.2.2.2.1 MCDData IPcon session establishment

The originating MCDData client procedures for MCDData IPcon session establishment shall conform to ETSI TS 124 282 [9], clause 20.2.1.

The terminating MCDData client procedures for MCDData IPcon session establishment shall conform to ETSI TS 124 282 [9], clause 20.2.2.

The FRMCS Service Domain shall support ETSI TS 124 282 [9], clauses 20.3 and 20.4 for MCDData IPcon session establishment.

6.2.2.2.2 MCDData IPcon media plane

The originating MCDData client procedures for MCDData IPcon media plane shall conform to ETSI TS 124 582 [10], clause 13.1.2.

The terminating MCDData client procedures for MCDData IPcon media plane shall conform to ETSI TS 124 582 [10] clause 13.1.3.

The FRMCS Service Domain shall support ETSI TS 124 582 [10], clauses 13.2 and 13.3 for MCDData IPcon media plane.

6.2.2.2.3 MCDData IPcon session release

The originating MCDData client procedures for MCDData IPcon session release shall conform to ETSI TS 124 282 [9], clause 13.2.2.2.1.

The terminating MCDData client procedures for MCDData IPcon session release shall conform to ETSI TS 124 282 [9], clause 13.2.2.2.2.

The FRMCS Service Domain shall support ETSI TS 124 282 [9], clauses 13.2.2.2.3, 13.2.2.2.4.2, 13.2.2.2.4.3 and 13.2.2.2.4.4 for MCDData IPcon session release.

If the caller entity indicates that the user has ended the call, the `RELEASE_CAUSE` in the SIP Reason header field of SIP BYE shall be set to 1 ("user ends call") as defined in ETSI TS 124 229 [13], clause 5.1.5 and Table 7.2A.18.11-2) on each hop from originating MCDData client up to the terminating MCDData client.

6.2.2.3 MCDData IPcon session establishment

6.2.2.3.1 On-Board-FRMCS-originated MCDData IPcon session establishment

The originating MCDData client shall send a MCDData IPcon session request to the MCDData server (see clause 6.2.2.2.1):

- If the MCDData client is configured by the On-Board FRMCS to use the Functional Alias as the recipient identifier, the originating MCDData Client shall set the `<call-to-functional-alias-ind>` element in the SIP INVITE to "true" as per ETSI TS 124 282 [9], clause 20.2.1 step 8, and shall insert the URI of the functional alias, which is passed to this procedure by the On-Board FRMCS, as a part of `<resource-lists>` element as per ETSI TS 124 282 [9], clause 20.2.1 step 7.
- The originating MCDData client shall fill the `<user-requested-priority>` element in the SIP INVITE as per ETSI TS 124 282 [9], clause 20.2.1 step 8, if a value is passed into this procedure by the On-Board FRMCS.

NOTE 1: The value of `<user-requested-priority>` is associated to the Communication Session Category as specified in clause 6.2.5 of the present document.

The following SIP response codes with the FRMCS-specific warning texts shall be supported by the MCDData clients and the FRMCS Service Domain:

- If the terminating application is not locally bound, the SIP response shall be set to 480 with warning text "FRMCS-Terminating application is not locally bound".

- If the terminating application is not allowed by profile to receive an incoming session, the SIP response shall be set to 403 with warning text "FRMCS-Terminating application is not allowed to receive an incoming session".
- If the incoming session timer (i.e. T_INCOMING_SESSION) is expired at the terminating FRMCS entity, the SIP response shall be set to 408 with warning text "FRMCS-Terminating application did not respond in time to session invitation".
- If the terminating application entity declined the request, the SIP response shall be set to 603 with warning text "FRMCS-Terminating application declined the request".

The IP management during the establishment of On-Board originated sessions of type Host-to-Host and Host-to-Network is described in clauses 6.2.2.4.2 and 6.2.2.4.3 respectively.

The <application-data> element within the AnyExt extension field of MCDData IPcon session request, sent on each hop from originating MCDData client up to the terminating MCDData client, shall be set as specified in clauses 6.2.2.4.2 and 6.2.2.4.3, respectively for Host-to-Host and Host-to-Network addressing schemes.

NOTE 2: The detailed format of <application-data> is not specified in the present document.

6.2.2.3.2 FRMCS-Trackside-originated MCDData IPcon session establishment

The originating MCDData client shall send a MCDData IPcon session request to the MCDData server (see clause 6.2.2.2.1):

- If the MCDData client is configured by the FRMCS Trackside Gateway to use the Functional Alias as the recipient identifier, the originating MCDData Client shall set the <call-to-functional-alias-ind> element in the SIP INVITE to "true" as per ETSI TS 124 282 [9], clause 20.2.1 step 8, and shall insert the URI of the functional alias, which is passed to this procedure by the FRMCS Trackside Gateway, as a part of <resource-lists> element as per ETSI TS 124 282 [9], clause 20.2.1 step.
- The originating MCDData client shall fill the <user-requested-priority> element in the SIP INVITE as per ETSI TS 124 282 [9], clause 20.2.1 step 8, if a value is passed into this procedure by the FRMCS Trackside Gateway.

NOTE 1: The value of <user-requested-priority> is associated to the Communication Session Category as specified in clause 6.2.5 of the present document.

The following SIP response codes with the FRMCS-specific warning texts shall be supported by the MCDData clients and the FRMCS Service Domain:

- If the terminating application is not locally bound, the SIP response shall be set to 480 with warning text "FRMCS-Terminating application is not locally bound".
- If the terminating application is not allowed by profile to receive an incoming session, the SIP response shall be set to 403 with warning text "FRMCS-Terminating application is not allowed to receive an incoming session".
- If the incoming session timer (i.e. T_INCOMING_SESSION) is expired at the terminating FRMCS entity, the SIP response shall be set to 408 with warning text "FRMCS-Terminating application did not respond in time to session invitation".
- If the terminating application entity declined the request, the SIP response shall be set to 603 with warning text "FRMCS-Terminating application declined the request".

NOTE 2: FRMCS Trackside Gateway cannot originate a Host-to-Network MCDData IPcon session.

The IP management during the establishment of a Trackside originated session of type Host-to-Host is described in clause 6.2.2.4.4.

The <application-data> element within the AnyExt extension field of MCDData IPcon session request, sent on each hop from originating MCDData client up to the terminating MCDData client, shall be set as specified in clause 6.2.2.4.4.

NOTE 3: The detailed format of <application-data> is not specified in the present document.

6.2.2.4 IP management and data transfer for H2H and H2N addressing schemes

6.2.2.4.1 IP layer model

The set of different IP address ranges relevant to a Loose Coupled Application is defined in ETSI TS 103 764 [i.2], clause 8. The MCDData signaling to setup MCDData IPcon tunnel between the On-Board FRMCS and the FRMCS Trackside Gateway is using the service domain IP address range (SD_PUB_IP).

If a MCDData client within the On-Board FRMCS is not using an IP within SD_PUB_IP, the On-Board FRMCS shall implement a NAT function to translate IP addresses used for MCDData signalling to and from the SD_PUB_IP range.

If a MCDData client within the FRMCS Trackside Gateway is not using an IP within SD_PUB_IP, the FRMCS Trackside Gateway, shall implement a NAT function to translate IP addresses used for MCDData signalling to and from the SD_PUB_IP range.

The following are the pre-requisite for the procedures in clauses 6.2.2.4.2 to 6.2.2.4.4:

- The On-Board Loose-Coupled Application has completed the Local Binding as per ETSI TS 103 765-3 [i.3], clause 7.3.1.1.
- The Trackside Application has completed the local binding as per ETSI TS 103 765-4 [i.4], clause 6.3.1.1.
- The On-Board FRMCS maintains a pool of virtual IPs in the range of OB_PRV_IP, called ViOB.
- The FRMCS Trackside Gateway maintains a pool of virtual IPs in the range of TS_FTG_IP, called ViTS.

NOTE: In the OB_{APP}/TS_{APP} API context, references to the Loose-Coupled Application also include the Super Loose-Coupled Application that utilizes an external API agent.

6.2.2.4.2 IP management during an On-Board-FRMCS-originated Host-to-Host session establishment

The IP management during the session establishment phase is done as follows (illustrated in Figure 6.2.2.4.2-1):

- 1) Upon the reception of a request on OB_{APP} for opening a session of type H2H, the On-Board FRMCS acts as specified in ETSI TS 103 765-3 [i.3], clause 7.3.2.1. If the request is valid:
 - a) the On-Board Loose-Coupled Application IP address, namely OBA1, is retrieved from the request.
 - b) The On-Board FRMCS selects one IP address from the ViOB, representing the Trackside Application for this OB_{APP} session within the On-Board FRMCS, namely the ViOB TSA1.
- 2) The MCDData IPcon session request initiated by the originating MCDData Client is forwarded up to the terminating MCDData Client as defined in clause 6.2.2.2.1 of the present document:
 - a) The <application-data> in the SIP requests sent on each hop from originating MCDData client up to the terminating MCDData client shall include IP address ViOB TSA1.
- 3) Upon reception of a MCDData IPcon session request at the FRMCS Trackside Gateway:
 - a) The FRMCS Trackside Gateway selects a virtual IP address out of the ViTS, representing the On-Board Loose-Coupled Application within the FRMCS Trackside Gateway, namely ViTS OBA1.
 - b) The FRMCS Trackside Gateway sends a notification of type "incomingSessionNotif" to the Trackside Application as per ETSI TS 103 765-4 [i.4], clause 6.3.2.3.
- 4) Upon reception of an incoming session acceptance response from the Trackside Application, the FRMCS Trackside Gateway retrieves the Trackside Application IP address (i.e. TSA1) from the response.
- 5) The Trackside Application Network NAT function (definition in ETSI TS 103 765-4 [i.4], clause 5.4.1) shall maintain the mapping between the couple IP addresses (OBA1, ViOB TSA1) and (ViTS OBA1, TSA1).
- 6) The MCDData IPcon session response initiated by the terminating MCDData Client is forwarded up to the originating MCDData Client as defined in clause 6.2.2.2.1 of the present document.

- 7) Upon the reception of the response in step 6, the On-Board FRMCS sends a notification of type "openSessionFinalAnswerNotif " to the On-Board Loose-Coupled Application (as per ETSI TS 103 765-3 [i.3], clause 7.3.2.1).
- 8) Upon the reception of SIP OK, the FRMCS Trackside Gateway should send a notification of type "openSessionFinalAnswerNotif " to the Trackside Application.

NOTE 1: Following this procedure, the On-Board Loose-Coupled Application will use the ViOB TSA1 (obtained at step 7) as the destination IP address for its outgoing IP packets linked to this H2H session.

NOTE 2: (If step 8 is not implemented): When the session is On-Board Originated, the first IP packet needs to be sent from On-Board towards the Trackside. The Trackside Application learns from the previously received packets which IP address to use as the destination IP address for its outgoing packets (i.e. ViTS OBA1).

NOTE 3: (If step 8 is implemented): Following this procedure, the Trackside Application will use the ViTS OBA1 (obtained at step 8) as the destination IP address for its outgoing IP packets linked to this H2H session.

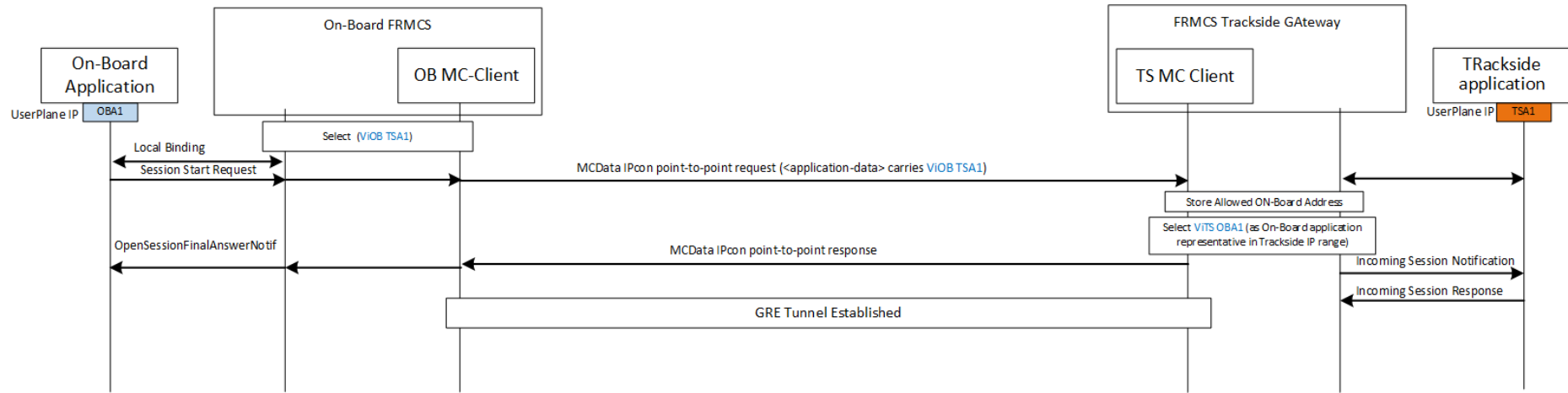

Figure 6.2.2.4.2-1: H2H session establishment

6.2.2.4.3 IP management during an On-Board-FRMCS-originated Host-to-Network session establishment

Pre-requisite: the H2N network endpoint is configured within FRMCS Trackside Gateway as defined in ETSI TS 103 765-4 [i.4], clause 6.1.2.

The IP management during the session establishment phase is done as follows:

- 1) Upon the reception of a request on OB_{APP} for opening a session of type H2N, the On-Board FRMCS acts as specified in ETSI TS 103 765-3 [i.3], clause 7.3.2.1. If the request is valid:
 - a) The On-Board Loose-Coupled Application IP address, namely $OBA1$, is retrieved from the request.
 - b) For this H2N session request, the On-Board FRMCS selects one IP address from the $ViOB$, representing the Trackside Application for this OB_{APP} session within the On-Board FRMCS, namely the $ViOB\ TSx$.
 - c) The $remoteId$ provided in the OB_{APP} request for a H2N session is mapped within the FROP to Functional Alias/MC Service ID representing the H2N network endpoint within FRMCS Trackside Gateway. The terminating MCDData Client in the following steps is the one associated to this MC Service ID.

NOTE 1: The $dns_request$ provided in the OB_{APP} request for a H2N session carries the FQDN of the intended application server whose DNS resolution is requested at the same time of session establishment. Alternatively, the application can directly provide the IP address of the intended application server (i.e. TSx) in $dns_request$.

- 2) The MCDData IPcon session request initiated by the originating MCDData IPcon is forwarded up to the terminating MCDData Client as defined in clause 6.2.2.2.1 of the present document. The $\langle application-data \rangle$ in the SIP requests sent on each hop from originating MCDData client up to the terminating MCDData client shall include the value provided in $dns_request$ of the OB_{APP} request and the IP address $ViOB\ TSx$.
- 3) Upon reception of a MCDData IPcon session request addressing a MCDData client representing the H2N Network endpoint within the FRMCS Trackside Gateway, if the $\langle application-data \rangle$ contains the FQDN of the Trackside Application server:
 - a) A DNS client within the FRMCS Trackside Gateway sends a DNS request for the resolution of the FQDN retrieved from $\langle application-data \rangle$ to the DNS server.
 - b) Upon the reception of the DNS response including TSx as the resolved IP address, the FRMCS Trackside Gateway selects a virtual IP address out of the $ViTS$, representing the On-Board Loose-Coupled Application within the FRMCS Trackside Gateway, namely $ViTS\ OBA1$.
- 4) The FRMCS Trackside Gateway maintains a mapping between the couple IP addresses ($OBA1$, $ViOB\ TSx$) and ($ViTS\ OBA1$, TSx) as specified in ETSI TS 103 765-4 [i.4], clause 5.4.1.
- 5) The MCDData IPcon session response initiated by the terminating MCDData Client is forwarded up to the originating MCDData Client as defined in clause 6.2.2.2.1 of the present document.
- 6) Upon the reception of the response in step 5, the On-Board FRMCS sends a notification of type "openSessionFinalAnswerNotif" towards the On-Board Loose-Coupled Application (as per ETSI TS 103 765-3 [i.3], clause 7.3.2.1).

NOTE 2: If the On-Board application is Super-Loose Coupled, the API agent needs also to include a DNS server. Upon reception of a DNS request from the On-Board SLC Application, the API agent sets the $dns_request$ parameter of OB_{APP} for opening a session to the FQDN to be resolved (which is retrieved from the DNS request).

6.2.2.4.4 IP management during a Trackside-Gateway-originated Host-to-Host session establishment

The IP management during the session establishment phase is done as follows:

- 1) Upon the reception of a request on TS_{APP} for opening a session of type H2H, the FRMCS Trackside Gateway acts as specified in ETSI TS 103 765-4 [i.4], clause 6.3.2.1. If the request is valid:
 - a) The Trackside Loose-Coupled Application IP address, namely TSA1, is retrieved from the request.
 - b) The FRMCS Trackside Gateway selects one IP address from the ViTS, representing the On-Board Application for this TS_{APP} session within the FRMCS Trackside Gateway, namely the ViTS OBA1.
- 2) The MCDData IPcon session request initiated by the originating MCDData Client is forwarded up to the terminating MCDData Client as defined in clause 6.2.2.2.1 of the present document.
- 3) Upon reception of a MCDData IPcon session request at the On-Board FRMCS:
 - a) The On-Board FRMCS selects a virtual IP address out of the ViOB, representing the Trackside Loose-Coupled Application within the On-Board FRMCS, namely ViOB TSA1.
 - b) The On-Board FRMCS sends a notification of type "incomingSessionNotif" to the On-Board Application as per ETSI TS 103 765-3 [i.3], clause 7.3.2.3.
- 4) Upon reception of an incoming session acceptance response from the On-Board Application, the On-Board FRMCS retrieves the On-Board Application IP address (i.e. OBA1) from the response.
- 5) The MCDData IPcon session response initiated by the terminating MCDData Client is forwarded up to the originating MCDData Client as defined in clause 6.2.2.2.1 of the present document:
 - a) The <application-data> in the SIP requests sent on each hop from terminating MCDData client up to the originating MCDData client shall include IP address ViOB TSA1.
- 6) The Trackside Application Network NAT function (definition in ETSI TS 103 765-4 [i.4], clause 5.4.1) shall maintain the mapping between the couple IP addresses (OBA1, ViOB TSA1) and (ViTS OBA1, TSA1).
- 7) Upon the reception of the response in step 5, the FRMCS Trackside Gateway sends a notification of type "openSessionFinalAnswerNotif " to the Trackside Loose-Coupled Application (as per ETSI TS 103 765-4 [i.4], clause 6.3.2.1).
- 8) Upon the reception of SIP OK, the On-Board FRMCS should send a notification of type "openSessionFinalAnswerNotif " to the On-Board Application.

NOTE 1: Following this procedure, the Trackside Loose-Coupled Application will use the ViTS OBA1 (obtained at step 5) as the destination IP address for its outgoing IP packets linked to this H2H session.

NOTE 2: If step 8 is not implemented: When the session is Trackside Originated, the first IP packet needs to be sent from Trackside towards the On-Board. The On-Board Application learns from the previously received packets which IP address to use as the destination IP address for its outgoing packets (i.e. ViOB TSA1).

NOTE 3: If step 8 is implemented: Following this procedure, the On-Board Application can use the ViOB TSA1 (obtained at step 8) as the destination IP address for its outgoing IP packets linked to this H2H session.

6.2.2.4.5 Data transfer from the On-Board-FRMCS to the FRMCS Trackside Gateway

For Data transfer from the On-Board-FRMCS to the FRMCS Trackside Gateway, the following steps are undertaken (see Figure 6.2.2.4.5-1 and clause 6.2.2.2.2):

- 1) The MCDData client within the On-Board FRMCS encapsulates the incoming IP packets from the On-Board LC Application (source: OBA1, destination: ViOB TSA1) into the MCDData IPcon GRE over UDP tunnel.
- 2) The MCDData client within FRMCS Trackside Gateway decapsulates the packets arriving from the GRE tunnel.
- 3) The Trackside Application Network NAT shall replace the source and destination IP addresses (source: OBA1, destination: ViOB TSA1) in the decapsulated IP packet of step 2 by (source: ViTS OBA1, destination: TSA1).
- 4) The FRMCS Trackside Gateway shall forward the packet resulting from step 3 towards the Trackside LC Application.

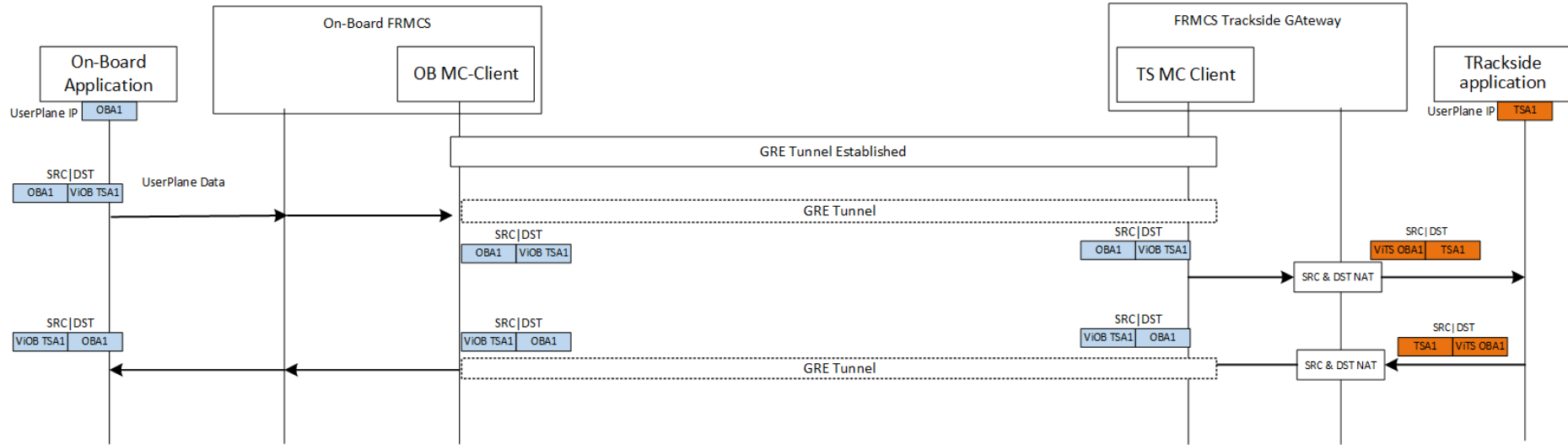

**Figure 6.2.2.4.5-1: H2H data transfer in both direction:
(top) from On-Board to Trackside and (bottom) from Trackside to On-Board**

6.2.2.4.6 Data transfer from the FRMCS Trackside Gateway to the On-Board-FRMCS

For Data transfer from a FRMCS Trackside Gateway to an On-Board-FRMCS, the following steps are undertaken (see Figure 6.2.2.4.5-1 and clause 6.2.2.2.2):

- 1) The Trackside Application Network NAT shall replace the source and destination IP addresses (source: TSA1, destination: ViTS OBA1) in the incoming IP packets from the Trackside LC Application by (source: ViOB TSA1, destination: OBA1).
- 2) The MCDData client within the FRMCS Trackside Gateway encapsulates the IP packets resulted from the step 1 (source: ViOB TSA1, destination: OBA1) into the MCDData IPcon GRE over UDP tunnel.
- 3) The MCDData client within the On-Board FRMCS decapsulates the packets arriving from the GRE tunnel.
- 4) The On-Board FRMCS shall forward the packet resulting from step 3 towards the On-Board LC Application.

6.2.2.5 MCDData IPcon session release

When this procedure is called by either On-Board FRMCS or FRMCS Trackside Gateway, the corresponding MCDData client shall initiate the release of the MCDData communication (see clause 6.2.2.2.3).

6.2.3 MCDData SDS

The FRMCS Service Domain shall support ETSI TS 124 282 [9], clauses 9.2.2.3.1 (excluding step 4a) and 9.2.2.4.2 (excluding step 6).

6.2.4 MCDData File Distribution

The present document does not specify normative requirements for MCDData file distribution service.

6.2.5 QoS and priority signalling

User's requested priority from MC session request as per ETSI TS 123 280 [2] shall be used for indicating the requested QoS and priority to the MC Service Server. Requested priority shall be used to uniquely identify railway communication session categories.

The conveyance of <user-requested-priority> in the SIP INVITE messages during the call establishment is defined per MC Service in clause 6.

The <user-requested-priority> value shall be 6 digit non-negative integer starting with non-zero digit. Format of <user-requested-priority> shall be [Communication Session Category] [Sub-category] where:

- [Communication Session Category] is 4 digit field that uniquely indicates Communication Session Category.
- [Sub-category] is 2-digit field that uniquely indicates further priority distinction within the same Communication Session Category.

The <user-requested-priority> field of the SIP INVITE shall be used between the MC Service Client and (MC Service Server of) the FRMCS Service Domain. The Resource-Priority header field of the SIP INVITE shall always be set to "Normal".

NOTE: The mapping of the combination of Communication Session Category and Sub-category to the <user-requested-priority> field of SIP INVITE needs to be consistent between the MC Service Client and its serving FRMCS Service Domains (an example of such mapping is presented in Table A-1).

The Application Function shall send relevant QoS and priority parameters (i.e. *afAppId* and *resPrio*, as specified in ETSI TS 103 765-1 [15], clause 8.1) over Rx or N5 interfaces.

6.2.6 Functional aliasing

This clause describes the functional aliasing for FRMCS Service Domain.

The procedures for MCDATA server serving the MCDATA user for management of functional alias shall conform to ETSI TS 124 282 [9], clause 8.3.2.

The procedures for MCDATA server owning functional alias shall conform to ETSI TS 124 282 [9], clause 8.3.3.

The procedures for MCPTT server serving the MCPTT user for management of functional alias shall conform to ETSI TS 124 379 [7], clause 9A.2.2.2.

The procedures for MCPTT server owning functional alias shall conform to ETSI TS 124 379 [7], clause 9A.2.2.3.

6.2.7 Arbitration

The present document does not specify normative requirements with respect to arbitration.

6.3 MC User deregistration

6.3.1 MC User deregistration in Home FRMCS Service Domain

This clause describes the MC Service User deregistration in Home FRMCS Service Domain. MC Service User deregistration implies MC Service User can no longer receive MC services and SIP services.

Pre-requisite: the ongoing communications of the MC Service User are released.

If this procedure is initiated by its caller entity (e.g. within On-Board FRMCS or FRMCS Trackside Gateway), the MC Service Client shall perform the user-initiated SIP deregistration procedure as specified in ETSI TS 124 229 [13], clause 5.1.1.6.

6.3.2 MC User deregistration in Foreign FRMCS Service Domain

This clause describes the MC Service User deregistration in Foreign FRMCS Service Domain. MC Service User deregistration implies MC Service User can no longer receive MC services and SIP services.

Pre-requisite: the ongoing communications of the MC Service User is released.

If this procedure is initiated by its caller entity (i.e. On-Board FRMCS in ETSI TS 103 765-3 [i.3]), the MC Service Client deregistration procedure in Foreign FRMCS Service Domain is constituted of the following steps:

Step 1- Migrated MC Service User deauthorization

For a migrated MC Service user, the MC Service Client shall initiate migration service deauthorization procedure as described in clause 6.4.2. of the present document.

Step 2 - User-initiated SIP deregistration

The MC Service Client shall perform the user-initiated SIP deregistration procedure as specified in ETSI TS 124 229 [13], clause 5.1.1.6.

6.3.3 Network initiated MC User deregistration

The present document does not specify network initiated MC Service User deregistration.

6.4 Inter FRMCS service domain transition

6.4.1 MC Service User migration

This clause describes the steps that shall be undertaken for MC User migration of a given MC User. The values passed into this procedure by its caller entity shall be used by the IdM Client and individual MC Service clients involved in the procedures referenced below.

Precondition: The MC User is authenticated, and the MC Service client has selected the user profile which permits migration to the selected partner MC system as described in ETSI TS 133 180 [5], clause C.2.

NOTE 1: The "selected partner MC system" is the one which is associated to the Foreign FRMCS Service Domain.

Step 1 - Security token acquisition from the primary MC system

The IdM Client procedures for security token acquisition from primary MC system shall conform to ETSI TS 124 482 [3], clause 6.2.2.

The IdM Server procedures for security token acquisition from primary MC system shall conform to ETSI TS 124 482 [3], clause 6.3.2.

Step 2 - MC token acquisition from the partner MC system

The IdM Client procedures for token acquisition from partner MC system shall conform to ETSI TS 124 482 [3], clause 6.2.3.

The IdM Server procedures for user authentication in the partner MC system shall conform to ETSI TS 124 482 [3], clause 6.3.3.

Step 3 - Configuration of MC service user profile and MC service group in the partner MC system

The MC procedures for subscribing to the MCS UE configuration document, the MCS user profile configuration document and the MCS service configuration document for each enabled MC Service shall conform to ETSI TS 124 484 [4], clause 4.2.2 for the online configuration case.

Step 4 - Service authorization for migration to the partner MC system

The MCPTT client procedure for migration service authorization shall conform to ETSI TS 124 379 [7], clause 7A.2.

The partner MCPTT server procedure for migration service authorization shall conform to ETSI TS 124 379 [7], clause 7A.3.

The partner MCPTT gateway server procedure for migration service authorization shall conform to ETSI TS 124 379 [7], clause 7A.4.

The primary MCPTT gateway server procedure for migration service authorization shall conform to ETSI TS 124 379 [7], clause 7A.5.

The primary MCPTT server procedure for migration service authorization shall conform to ETSI TS 124 379 [7], clause 7A.6.

NOTE 2: How the MCPTT gateway server determines the public service identity of the targeted MCPTT function in the interconnected MCPTT system or the URI of the MCPTT gateway server in the interconnected MCPTT system is out of the scope of the present document.

The MCDData client procedure for migration service authorization shall conform to ETSI TS 124 282 [9], clause 7A.2.

The partner MCDData server procedure for migration service authorization shall conform to ETSI TS 124 282 [9], clause 7A.3.

The partner MCDData gateway server procedure for migration service authorization shall conform to ETSI TS 124 282 [9], clause 7A.4.

The primary MCDData gateway server procedure for migration service authorization shall conform to ETSI TS 124 282 [9], clause 7A.5.

The primary MCDATA server procedure for migration service authorization shall conform to ETSI TS 124 282 [9], clause 7A.6.

NOTE 3: How the MCDATA gateway server determines the public service identity of the targeted MCDATA function in the interconnected MCDATA system or the URI of the MCDATA gateway server in the interconnected MCDATA system is out of the scope of the present document.

NOTE 4: FS_{NNI} interface is used for Inter-domain exchanges. For out of band sharing between Home & Foreign FRMCS Service Domain, FS_{NNI} conforms to SAP interconnection as described in clause 5.2.2 of the present document.

6.4.2 Migrated MC Service user deauthorization

This clause describes the requirements for migrated MC Service user deauthorization when the user leaves a Foreign FRMCS Service Domain (to move to another Foreign FRMCS Service Domain or to go back to the Home FRMCS Service Domain).

The MCPTT client procedure for MC user migration deauthorization shall conform to ETSI TS 124 379 [7], clause 7A.2.3.

The partner MCPTT server procedure for migration service deauthorization shall conform to ETSI TS 124 379 [7], clause 7A.3.7.

The partner MCPTT gateway server procedure for migration service deauthorization shall conform to ETSI TS 124 379 [7], clause 7A.4.

The primary MCPTT gateway server procedure for migration service deauthorization shall conform to ETSI TS 124 379 [7], clause 7A.5.

The primary MCPTT server procedure for migration service deauthorization shall conform to ETSI TS 124 379 [7], clause 7A.6.2.

NOTE 1: How the MCPTT gateway server determines the public service identity of the targeted MCPTT function in the interconnected MCPTT system or the URI of the MCPTT gateway server in the interconnected MCPTT system is out of the scope of the present document.

The MCDATA client procedure for migration service deauthorization shall conform to ETSI TS 124 282 [9], clause 7A.2.3.

The partner MCDATA server procedure for migration service deauthorization shall conform to ETSI TS 124 282 [9], clause 7A.3.6.

The partner MCDATA gateway server procedure for migration service deauthorization shall conform to ETSI TS 124 282 [9], clause 7A.4.

The primary MCDATA gateway server procedure for migration service deauthorization shall conform to ETSI TS 124 282 [9], clause 7A.5.

The primary MCDATA server procedure for migration service deauthorization shall conform to ETSI TS 124 282 [9], clause 7A.6.2.

NOTE 2: How the MCDATA gateway server determines the public service identity of the targeted MCDATA function in the interconnected MCDATA system or the URI of the MCDATA gateway server in the interconnected MCDATA system is out of the scope of the present document.

6.5 Communications encompassing multiple FRMCS Service Domains

6.5.1 MCPTT voice services in interconnected FRMCS service Domains

The MCPTT procedures in clause 6.2.1 apply for interconnected FRMCS Service Domains.

If the interconnected FRMCS Service Domains are considered to be in different trust domains, the FRMCS Service Domain shall conform to the procedures regarding MC Gateway Server as defined in ETSI TS 124 379 [7], clause 6.8.

6.5.2 MCDData IP Connectivity in interconnected FRMCS Service Domains

The MCDData IPcon procedures in clause 6.2.2 apply for interconnected FRMCS Service Domains.

If the interconnected FRMCS Service Domains are considered to be in different trust domains, the FRMCS Service Domain shall conform to the procedures regarding MC Gateway Server as defined in ETSI TS 124 282 [9], clause 6.8.

Annex A (informative): Mapping table for Communication Session Category with User Requested Priority

Table A-1 provides an example mapping table between some Communication Session Category, Sub-category and the <user-requested-priority> field of the SIP INVITE.

Table A-1: Mapping for QoS and priority signalling

Communication Session Category	Sub-category	<user-requested-priority> field of the SIP request
FRMCS Signaling	N/A	100000
Predefined Default	N/A	100100
Emergency Voice	N/A	101100
Voice	Urgent Driver-to-Controller	100200
	Normal Driver-to-Controller	100201
TCMS	N/A	111900
ATP Regular Data	N/A	110400
ATP Compl. Data	N/A	111800
ATO Data	N/A	110500

History

Version	Date	Status	
V1.0.0	July 2025	SRdAP process	EV 20251008: 2025-07-10 to 2025-10-08
V1.1.0	November 2025	SRdAP process	VA 20260106: 2025-11-07 to 2026-01-06
V1.1.1	January 2026	Publication	