

ETSI TS 103 792 V1.1.1 (2026-01)



TECHNICAL SPECIFICATION

**Rail Telecommunications (RT);
Future Railway Mobile Communication System (FRMCS);
Interworking with GSM-R**

Reference

DTS/RT-0088

Keywords

FRMCS, GSM-R, interworking, railways

ETSI

650 Route des Lucioles
F-06921 Sophia Antipolis Cedex - FRANCE

Tel.: +33 4 92 94 42 00 Fax: +33 4 93 65 47 16

Siret N° 348 623 562 00017 - APE 7112B
Association à but non lucratif enregistrée à la
Sous-Préfecture de Grasse (06) N° w061004871

Important notice

The present document can be downloaded from the
[ETSI Search & Browse Standards](#) application.

The present document may be made available in electronic versions and/or in print. The content of any electronic and/or print versions of the present document shall not be modified without the prior written authorization of ETSI. In case of any existing or perceived difference in contents between such versions and/or in print, the prevailing version of an ETSI deliverable is the one made publicly available in PDF format on [ETSI deliver](#) repository.

Users should be aware that the present document may be revised or have its status changed,
this information is available in the [Milestones listing](#).

If you find errors in the present document, please send your comments to
the relevant service listed under [Committee Support Staff](#).

If you find a security vulnerability in the present document, please report it through our
[Coordinated Vulnerability Disclosure \(CVD\)](#) program.

Notice of disclaimer & limitation of liability

The information provided in the present deliverable is directed solely to professionals who have the appropriate degree of experience to understand and interpret its content in accordance with generally accepted engineering or other professional standard and applicable regulations.

No recommendation as to products and services or vendors is made or should be implied.

No representation or warranty is made that this deliverable is technically accurate or sufficient or conforms to any law and/or governmental rule and/or regulation and further, no representation or warranty is made of merchantability or fitness for any particular purpose or against infringement of intellectual property rights.

In no event shall ETSI be held liable for loss of profits or any other incidental or consequential damages.

Any software contained in this deliverable is provided "AS IS" with no warranties, express or implied, including but not limited to, the warranties of merchantability, fitness for a particular purpose and non-infringement of intellectual property rights and ETSI shall not be held liable in any event for any damages whatsoever (including, without limitation, damages for loss of profits, business interruption, loss of information, or any other pecuniary loss) arising out of or related to the use of or inability to use the software.

Copyright Notification

No part may be reproduced or utilized in any form or by any means, electronic or mechanical, including photocopying and microfilm except as authorized by written permission of ETSI.

The content of the PDF version shall not be modified without the written authorization of ETSI.

The copyright and the foregoing restriction extend to reproduction in all media.

© ETSI 2026.
All rights reserved.

Contents

Intellectual Property Rights	6
Foreword.....	6
Modal verbs terminology.....	6
Introduction	6
1 Scope	8
2 References	8
2.1 Normative references	8
2.2 Informative references.....	9
3 Definition of terms, symbols and abbreviations.....	10
3.1 Terms.....	10
3.2 Symbols.....	11
3.3 Abbreviations	11
4 Services	12
4.1 General	12
4.2 Group call.....	12
4.3 Emergency group call.....	13
4.4 Point-to-point call.....	13
4.5 Text messaging service	13
5 Functional model.....	13
5.1 Functional model description	13
5.2 Reference points	14
5.2.0 General.....	14
5.2.1 Reference point IWF-1 (between the IWF and the MCPTT server).....	15
5.2.2 Reference point IWF-2 (between the IWF and the MCDATA server)	15
5.2.3 Reference point IWF-3 (between the IWF and the group management server).....	15
5.2.4 Reference point IWF-g1 (between the IWF and the MSC server/MGCF)	15
5.2.5 Reference point IWF-g2 (between the IWF and MGW).....	15
5.2.6 Reference point IWF-g5 (between the IWF and IP-SM-GW)	16
6 Identities and addressing	16
6.0 General	16
6.1 Identity definitions	16
6.2 Representation in interworking systems.....	17
6.3 Identity mapping and addressing.....	18
6.3.0 General.....	18
6.3.1 Management policies for identity mapping and routing	18
6.3.1.1 General.....	18
6.3.1.2 Examples for the changing of the domain in SIP URIs.....	19
6.3.2 SIP routing services	20
6.3.2.1 GSM-R to FRMCS out-of-dialog SIP requests	20
6.3.2.2 FRMCS to GSM-R out-of-dialog SIP requests	20
6.3.3 Identity mapping services	21
6.3.3.0 General	21
6.3.3.1 Generic procedures for identity mapping.....	21
6.3.3.1.0 General	21
6.3.3.1.1 Generic identity mapping for GSM-R to FRMCS SIP messages	21
6.3.3.1.2 Generic identity mapping for FRMCS to GSM-R SIP messages	22
6.3.3.2 Mapping of basic address parameters for MCPTT private calls	22
6.3.3.2.0 General	22
6.3.3.2.1 Basic address parameters for GSM-R to FRMCS private calls	23
6.3.3.2.2 Basic address parameters for FRMCS to GSM-R private calls	23
6.3.3.3 Identity mapping for MCDATA SDS.....	24
6.3.3.3.0 General	24

6.3.3.3.1	Address parameters for GSM-R to FRMCS text messages	24
6.3.3.3.2	Address parameters for FRMCS to GSM-R text messages	25
6.3.3.4	Identity mapping for supplementary services.....	25
6.3.3.4.0	General	25
6.3.3.4.1	Presentation of Functional Number - User To User Information	26
6.3.3.4.2	Call Diversion - Call History Address List.....	26
6.3.3.4.3	Explicit Call Transfer - Connected Address	27
6.3.3.5	Mapping of Identities, Criteria and Domains for MCPTT group calls.....	27
6.3.3.5.0	General	27
6.3.3.5.1	Mapping of basic address parameters for MCPTT group calls	28
6.3.3.5.2	Mapping of FRMCS criteria and EIRENE CT5 FN.....	28
7	Group calls	29
7.1	Interworking procedures.....	29
7.1.0	General.....	29
7.1.1	Information flows	30
7.1.1.1	Stage 2 information flows	30
7.1.1.1.1	General	30
7.1.1.1.2	IWF GSM-R IWF ad-hoc group call request.....	31
7.1.1.1.3	IWF GSM-R IWF ad-hoc group call response	31
7.1.1.2	Stage 3 Information flows	31
7.2	Group call principles	32
7.2.1	Group call initiated by a GSM-R user	32
7.2.1.1	Group call initiated by a GSM-R user interacting with MCPTT group call.....	32
7.2.1.1.1	Stage 2 procedure	32
7.2.1.1.2	Stage 3 procedure	33
7.2.2	Group call initiated by an MCPTT user.....	35
7.2.2.1	Group call setup initiated by MCPTT user interacting with the GSM-R system	35
7.2.2.1.1	Stage 2 procedure	35
7.2.2.1.2	Stage 3 procedure	37
7.2.3	Late entry	39
7.2.3.1	Late entry of an MCPTT user	39
7.2.3.1.1	Stage 2 procedure	39
7.2.3.1.2	Stage 3 procedure	41
7.2.3.2	Late entry of a GSM-R user	41
7.2.3.2.1	Stage 2 procedure	41
7.2.3.2.2	Stage 3 procedure	42
7.2.4	Group call release	42
7.2.4.1	General	42
7.2.4.2	Group call release initiated from the GSM-R side	42
7.2.4.2.1	Procedure.....	42
7.2.4.3	Group call release initiated from the MCPTT side	43
7.2.4.3.1	Procedure.....	43
7.2.5	Talker control.....	44
7.2.5.1	General	44
7.2.5.2	Talker control operation initiated from the GSM-R side	44
7.2.5.2.1	Procedure.....	44
7.2.5.3	Talker control operation initiated from the MCPTT side.....	45
7.2.5.3.1	Procedure.....	45
7.2.6	Handling of mute and unmute in GSM-R.....	47
7.2.6.1	General	47
7.2.6.2	Procedure	47
7.2.7	Media encryption	49
7.2.8	Codec negotiation	49
7.2.8.1	Codec negotiation for calls initiated by MCPTT user.....	49
7.2.8.2	Codec negotiation for calls initiated by GSM-R user	49
7.2.9	Codec transcoding	50
8	Point-to-point call.....	50
8.1	General	50
8.2	Point-to-point call from GSM-R user to user on MCPTT system.....	51
8.2.1	Point-to-point call	51

8.2.1.1	Stage 2 procedure.....	51
8.2.1.2	Stage 3 procedure.....	51
8.2.2	Point-to-point call rejected by MCPTT system	53
8.2.2.1	Stage 2 procedure.....	53
8.2.2.2	Stage 3 procedure.....	53
8.3	Point-to-point call initiated by an MCPTT user	54
8.3.1	Point-to-point call	54
8.3.1.1	Stage 2 procedure.....	54
8.3.1.2	Stage 3 procedure.....	54
8.3.2	Point-to-point call rejected by GSM-R system	55
8.3.2.1	Stage 2 procedure.....	55
8.3.2.2	Stage 3 procedure.....	55
8.4	Point-to-point call release.....	56
8.4.1	Individual call release by GSM-R user	56
8.4.1.1	Stage 2 procedure.....	56
8.4.1.2	Stage 3 procedure.....	56
8.4.2	Individual call release by FRMCS user	57
8.4.2.1	Stage 2 procedure.....	57
8.4.2.2	Stage 3 procedure.....	57
9	Text messaging service	58
9.1	General	58
9.2	One-to-one text messaging procedures.....	58
9.2.1	One-to-one SDS to Instant Messaging interworking principles.....	58
9.3	One-to-One text messaging protocols IWF to/from the MCDATA server.....	61
Annex A (informative): Voice transcoding to and from AMR-WB when AMR-WB is not supported by a GSM-R system		63
A.1	Introduction	63
A.2	Transcoding in a GSM-R system	63
A.3	Implementation of transcoding in the FRMCS Domain.....	63
History	64

Intellectual Property Rights

Essential patents

IPRs essential or potentially essential to normative deliverables may have been declared to ETSI. The declarations pertaining to these essential IPRs, if any, are publicly available for **ETSI members and non-members**, and can be found in ETSI SR 000 314: "*Intellectual Property Rights (IPRs); Essential, or potentially Essential, IPRs notified to ETSI in respect of ETSI standards*", which is available from the ETSI Secretariat. Latest updates are available on the [ETSI IPR online database](#).

Pursuant to the ETSI Directives including the ETSI IPR Policy, no investigation regarding the essentiality of IPRs, including IPR searches, has been carried out by ETSI. No guarantee can be given as to the existence of other IPRs not referenced in ETSI SR 000 314 (or the updates on the ETSI Web server) which are, or may be, or may become, essential to the present document.

Trademarks

The present document may include trademarks and/or tradenames which are asserted and/or registered by their owners. ETSI claims no ownership of these except for any which are indicated as being the property of ETSI, and conveys no right to use or reproduce any trademark and/or tradename. Mention of those trademarks in the present document does not constitute an endorsement by ETSI of products, services or organizations associated with those trademarks.

DECT™, **PLUGTESTS™**, **UMTS™** and the ETSI logo are trademarks of ETSI registered for the benefit of its Members. **3GPP™**, **LTE™** and **5G™** logo are trademarks of ETSI registered for the benefit of its Members and of the 3GPP Organizational Partners. **oneM2M™** logo is a trademark of ETSI registered for the benefit of its Members and of the oneM2M Partners. **GSM®** and the GSM logo are trademarks registered and owned by the GSM Association.

Foreword

This Technical Specification (TS) has been produced by ETSI Technical Committee Railway Telecommunications (RT).

Modal verbs terminology

In the present document "**shall**", "**shall not**", "**should**", "**should not**", "**may**", "**need not**", "**will**", "**will not**", "**can**" and "**cannot**" are to be interpreted as described in clause 3.2 of the [ETSI Drafting Rules](#) (Verbal forms for the expression of provisions).

"**must**" and "**must not**" are **NOT** allowed in ETSI deliverables except when used in direct citation.

Introduction

GSM-R has been a great success not only in Europe, where more than 100 000 km of railway tracks are daily operated through GSM-R, but also worldwide, and this number will double within the next years due to the on-going installations of this technology all over the world.

As the needs of the railways are constantly evolving, in particular in the context of the digitalisation of rail operation that is pursued in many countries and considering the upcoming obsolescence of GSM-R technology, UIC launched in 2012 the first studies for a successor to GSM-R, pertinently named Future Railway Mobile Communication System (FRMCS). The UIC project then concretely delivered the FRMCS Functional Requirements Specifications (FRS) [1] and FRMCS System Requirement Specifications (SRS) [2] focusing mainly on rail communication needs - as a basis for the development of the GSM-R successor.

The present document has been written to satisfy the identified need for interworking between GSM-R and the FRMCS Mission Critical applications specified by 3GPP, to enable communications between users and groups operating on the two system technologies. It provides solutions to the considerations documented in ETSI TR 103 768 [1.1], which studied the issues for interworking between the two technologies.

1 Scope

The present document defines the functional model including reference points as well as the protocol and procedure for interworking between GSM-R R4 and FRMCS and covers the following services:

- Group call.
- Emergency group call.
- Point-to-point call.
- Text messaging Service.

2 References

2.1 Normative references

References are either specific (identified by date of publication and/or edition number or version number) or non-specific. For specific references, only the cited version applies. For non-specific references, the latest version of the referenced document (including any amendments) applies.

Referenced documents which are not found to be publicly available in the expected location might be found in the [ETSI docbox](#).

NOTE: While any hyperlinks included in this clause were valid at the time of publication, ETSI cannot guarantee their long-term validity.

The following referenced documents are necessary for the application of the present document.

- [1] [UIC FU-7120](#): "Future Railway Mobile Communication System - Functional Requirements Specification", Version 2.0.0 December 13th, 2024.
- [2] [UIC FW-AT 7800](#): "Future Railway Mobile Communication System - System Requirements Specification", Version 2.0.0 December 13th, 2024.
- [3] [UIC FIS-7970](#): "Future Railway Mobile Communication System - Functional Interface Specification", Version 2.0.0 December 13th, 2024.
- [4] [ETSI TS 103 765-2](#): "Rail Telecommunications (RT); Future Railway Mobile Communication System (FRMCS); Building blocks and functions; Part 2: Service Stratum".
- [5] [IETF RFC 8101](#): "IANA Registration of New Session Initiation Protocol (SIP) Resource-Priority Namespace for Mission Critical Push To Talk Service".
- [6] [ETSI TS 103 389 \(V3.4.1\)](#): "Rail Telecommunications (RT); Global System for Mobile communications (GSM); Usage of Session Initiation Protocol (SIP) on the Network Switching Subsystem (NSS) to Fixed Terminal Subsystem (FTS) interface for GSM Operation on Railways".
- [7] [ETSI TS 123 228 \(V18.9.0\)](#): "Digital cellular telecommunications system (Phase 2+) (GSM); Universal Mobile Telecommunications System (UMTS); LTE; 5G; IP Multimedia Subsystem (IMS); Stage 2 (3GPP TS 23.228 version 18.9.0 Release 18)".
- [8] [ETSI TS 129 379 \(V18.0.0\)](#): "LTE; 5G; Mission Critical Push To Talk (MCPTT) call control interworking with Land Mobile Radio (LMR) systems; Stage-3 (3GPP TS 29.379 version 18.0.0 Release 18)".
- [9] [ETSI TS 124 282 \(V18.10.0\)](#): "LTE; Mission Critical Data (MCDATA) signalling control; Protocol specification (3GPP TS 24.282 version 18.10.0 Release 18)".
- [10] [ETSI TS 124 379 \(V18.10.0\)](#): "LTE; Mission Critical Push To Talk (MCPTT) call control; Protocol specification (3GPP TS 24.379 version 18.10.0 Release 18)".

- [11] [ETSI TS 123 283 \(V18.3.0\)](#): "LTE; Mission Critical Communication Interworking with Land Mobile Radio Systems (3GPP TS 23.283 version 18.3.0 Release 18)".
- [12] [ETSI TS 129 163 \(V18.1.0\)](#): "Digital cellular telecommunications system (Phase 2+) (GSM); Universal Mobile Telecommunications System (UMTS); LTE; 5G; Interworking between the IP Multimedia (IM) Core Network (CN) subsystem and Circuit Switched (CS) networks (3GPP TS 29.163 version 18.1.0 Release 18)".
- [13] [ETSI TS 133 180 \(V18.1.0\)](#): "LTE; Security of the Mission Critical (MC) service (3GPP TS 33.180 version 18.1.0 Release 18)".
- [14] [IETF RFC 3428](#): "Session Initiation Protocol (SIP) Extension for Instant Messaging".
- [15] [IETF RFC 5373](#): "Requesting Answering Modes for the Session Initiation Protocol (SIP)".
- [16] [IETF RFC 3261](#): "SIP: Session Initiation Protocol".
- [17] [IETF RFC 3841](#): "Caller Preferences for the Session Initiation Protocol (SIP)".

2.2 Informative references

References are either specific (identified by date of publication and/or edition number or version number) or non-specific. For specific references, only the cited version applies. For non-specific references, the latest version of the referenced document (including any amendments) applies.

NOTE: While any hyperlinks included in this clause were valid at the time of publication, ETSI cannot guarantee their long-term validity.

The following referenced documents may be useful in implementing an ETSI deliverable or add to the reader's understanding, but are not required for conformance to the present document.

- [i.1] ETSI TR 103 768: "Rail Telecommunications (RT); Future Rail Mobile Communication System (FRMCS); Interworking study with legacy systems".
- [i.2] EIRENE System Requirements Specification, Version 16.1.0, February 2023.
- [i.3] ETSI TS 123 280 (V18.12.0): "LTE; Common functional architecture to support mission critical services; Stage 2".
- [i.4] ETSI TS 123 040 (V18.0.0): "Digital cellular telecommunications system (Phase 2+) (GSM); Universal Mobile Telecommunications System (UMTS); LTE; 5G; Technical realization of the Short Message Service (SMS) (3GPP TS 23.040 version 18.0.0 Release 18)".
- [i.5] ETSI TS 123 002 (V18.0.0): "Digital cellular telecommunications system (Phase 2+) (GSM); Universal Mobile Telecommunications System (UMTS); LTE; Network architecture (3GPP TS 23.002 version 18.0.0 Release 18)".
- [i.6] ETSI TS 123 379 (V18.12.0): "LTE; Functional architecture and information flows to support Mission Critical Push To Talk (MCPTT); Stage 2 (3GPP TS 23.379 version 18.12.0 Release 18)".
- [i.7] ETSI TS 123 282 (V18.10.0): "LTE; Functional architecture and information flows to support Mission Critical Data (MCData); Stage 2 (3GPP TS 23.282 version 18.10.0 Release 18)".
- [i.8] ETSI TS 143 068 (V18.0.0): "Digital cellular telecommunications system (Phase 2+) (GSM); Voice Group Call Service (VGCS); Stage 2 (3GPP TS 43.068 version 18.0.0 Release 18)".
- [i.9] ETSI TS 123 236 (V18.0.0): "Digital cellular telecommunications system (Phase 2+) (GSM); Universal Mobile Telecommunications System (UMTS); LTE; Intra-domain connection of Radio Access Network (RAN) nodes to multiple Core Network (CN) nodes (3GPP TS 23.236 version 18.0.0 Release 18)".
- [i.10] ETSI TS 129 311 (V18.0.0): "Universal Mobile Telecommunications System (UMTS); LTE; Service Level Interworking (SLI) for messaging services (3GPP TS 29.311 version 18.0.0 Release 18)".

- [i.11] ETSI TS 124 229 (V18.7.0): "Digital cellular telecommunications system (Phase 2+) (GSM); Universal Mobile Telecommunications System (UMTS); LTE; 5G; IP multimedia call control protocol based on Session Initiation Protocol (SIP) and Session Description Protocol (SDP); Stage 3 (3GPP TS 24.229 version 18.7.0 Release 18)".
- [i.12] ETSI TR 103 791: "Rail Telecommunications (RT); Future Railway Mobile Communication System (FRMCS); Terminology for FRMCS specifications".
- [i.13] ETSI TS 123 283 (V18.2.0): "LTE; Mission Critical Communication Interworking with Land Mobile Radio Systems (3GPP TS 23.283 version 18.2.0 Release 18)".

3 Definition of terms, symbols and abbreviations

3.1 Terms

For the purposes of the present document, the terms given in ETSI TR 103 791 [i.12] and the following apply:

E.164 SIP-R URI: SIP-R URI which describes an international E.164 address

EIRENE SIP-R URI: SIP-R URI which describes an international EIRENE address

FA(164): Functional Alias (FA) which takes the form of an E.164 SIP-R URI and is transmitted in MCX related messages, according to the transmission of FAs

NOTE: As specified in ETSI TS 124 379 [10] and ETSI TS 124 282 [9].

FA(EIRENE): Functional Alias (FA) which takes the form of an EIRENE SIP-R URI and is transmitted in MCX related messages, according to the transmission of FAs

NOTE: As specified in ETSI TS 124 379 [10] and ETSI TS 124 282 [9].

FRMCS Entity: entity which is either:

- a) a user of the MCX system;
- b) a user of a partner MC system of the MCX system;
- c) a group of users of the MCX system;
- d) a group of users of a partner MC system of the MCX system;
- e) a railway function that is registered or activated as FA at the MCX system; or
- f) a railway function that is registered or activated as FA at a partner MC system of the MCX system.

GSM-R Entity: entity which is either GSM-R user, a GSM-R service or a railway function that is not an FRMCS entity

identity and criteria mapping: local service of the IWF for mapping between identities and criteria achieved without requests from the IWF to external data bases or other remote storage (i.e. it is achieved by local address lookup or by rule-based rephrasing)

local address lookup: local lookup of identity mappings within the IWF, e.g. by tables that have been setup during provisioning time

rephrasing: rule-based mapping of EIRENE addresses to FRMCS FAs and vice versa

NOTE: This rule-based rephrasing is based on FRMCS FRS [1].

subscribers: user identified by E.164 addresses.

NOTE: This can mean:

- a) GSM-R subscribers;

- b) Users of the MCX system;
- c) Groups of users of the MCX system.

3.2 Symbols

Void.

3.3 Abbreviations

For the purposes of the present document, the following abbreviations apply:

3GPP	3 rd Generation Partnership Project
AMR-WB	Adaptative MultiRate-Wide Band
CdA	Called Address
CgA	Calling Address
CHPC	Confirmation of High Priority Call
CSC	Coding Scheme Code
CT	Call Type
CT5	Call Type 5
ECT	Explicit Call Transfer
EIR	Equipment Identity Register
EIRENE	European Integrated Railway Radio Enhanced Network
ETSI	European Telecommunications Standards Institute
EVS-SWB	Enhanced Voice Service - Super Wide Band
FA	Functional Alias
FIS	Functional Interface Specification
FN	Functional Number
FRMCS	Future Railway Mobile Communication System
FRS	Functional Requirement Specification
FTS	Fixed Terminal Subsystem
GCR	Group Call Register
GCref	Group Call Reference
GID	Group call Identity
GPS	Global Positioning System
GSM	Global System for Mobile communications
GSM-R	Global System for Mobile communications - Railways
GW	GateWay
HLR	Home Location Register
IC	International Code
IE	Information Element
IETF	Internet Engineering Task Force
IM	Instant Messaging
IMS	IP Multimedia Subsystem
IMSI	International Mobile Subscriber Identity
IP	Internet Protocol
IP-SM-GW	IP Short Message Gateway
ISC	IP multimedia subsystem Service Control interface
IWF	InterWorking Function
IW-GW	InterWorking-GateWay
MAP	Mobile Application Part
MC	Mission-Critical
MCDATA	Mission-Critical Data
MCPPT	Mission Critical Push To Talk
MCPTT	Mission-Critical Push-To-Talk
MCX	Mission Critical communications
MDF	Media Distribution Frame
MGCF	Media Gateway Control Function
MGW	Media GateWay
MIME	Multipurpose Internet Mail Extensions

MS	Mobile Station
MSC	Mobile Switching Centre
MSS	Mobile Switching Subsystem
OIP	Originating Identification Presentation
OMA-TS	Open Mobile Alliance-Technical Specification
OTDI	Originator To Dispatcher Information
PABX	Private Automatic Branch eXchange
PAI	P-Asserted Identity
PFN	Presentation Functional Number
PTT	Push-To-Talk
REC	Railway Emergency Call
RFC	Request For Comments
RTCP	Real time Ta
S-CSCF	Serving-Call Session Control Function
SDP	Session Description Protocol
SDS	Short Data Service
SIM	Subscriber Identity Module
SIP	Session Initiation Protocol
SIP-R	Session Initiation Protocol for Railways
SLI	Service Level Interworking
SM	Short Message
SMPP	Short Message Peer-to-Peer protocol
SMS	Short Message Service
SMSC	Short Message Service Center
SRS	System Requirement Specification
TIP	Terminating Identification Presentation
TR	Technical Report
TS	Technical Specification
UE	User Equipment
URI	Uniform Resource Identifier
URN	Uniform Resource Number
VBS	Voice Broadcast Service
VGCS	Voice Group Call Service
XML	eXtensible Markup Language

4 Services

4.1 General

This clause describes the services for interworking between GSM-R and FRMCS 3GPP MC systems supported in the present document.

4.2 Group call

This clause describes group call services that are supported for groups defined on the MC system and groups defined on the GSM-R system.

The following group call procedures are supported:

- Initiation of a group call by a FRMCS user.
- Initiation of a group call by a GSM-R user.
- Late entry.
- Termination of a group call.
- Interworking of floor control on MCPTT with uplink control and dispatcher mute/unmute in GSM-R.

- Interworking of the media codecs and encryption between GSM-R and MCPTT.

4.3 Emergency group call

Emergency group calls, i.e. group calls with pre-emptive priority, are supported for the same cases as described in clause 4.2.

4.4 Point-to-point call

The following point-to-point call procedures are supported:

- Initiating a point-to-point call from a user on the GSM-R system to a user on the MC system.
- Initiating a point-to-point call from a user on the FRMCS system to a user on the GSM-R system.
- Interworking of the media codecs and encryption between GSM-R and MCPTT.
- Termination of a point-to-point call.

NOTE: Point-to-point calls for interworking are without floor control.

4.5 Text messaging service

The GSM-R system includes Mobile Stations (MS) capable of performing various types of calls, such as voice and data calls, and also supports text messaging by enabling the transmission of Short Messages (SMs) between mobile stations. EIRENE System Requirements Specification [i.2] specifies that, whenever text messaging is implemented in the GSM-R network, the Short Message Service (SMS) - is to be used (see clause 12.2.1 of EIRENE System Requirements Specification [i.2]).

The Short Message Service and Short Messages are defined in ETSI TS 123 040 [i.4].

The present document specifies Short Data Service (SDS) interworking between GSM-R users and MCDATA clients using one-to-one standalone SDS messages. The IWF behaves as a peer MCDATA server to other MCDATA servers for the FRMCS side and it implements the ISC interface as an S-CSCF, as the IP-SM-GW (SMS application server) is considered a part of the GSM-R side.

When a GSM-R user attempts to send a GSM-R message to the MCDATA service, the IWF converts the Instant Message from the IP-SM Gateway into a request to send an MCDATA SDS message. When an MCDATA user sends an SDS message to the GSM-R system, the IWF converts the message to an Instant Message and converts the destination and originating address using the same mapping techniques as in point-to-point voice calls. The IWF then forwards the Instant Message via the IP-SM-GW to the GSM-R SMSC.

NOTE: MCDATA SDS is limited to MCDATA SDS Text Messaging.

5 Functional model

5.1 Functional model description

The present document defines the reference points between the IWF and the FRMCS servers as well as the reference points between the IWF and the GSM-R nodes. Additionally, it defines the functionality of the IWF, which acts as an MC service server connected with the FRMCS MC service server utilizing the IWF-1 or IWF-2 reference points, including protocol translation, identity mapping, transcoding, routing and other functions, to be performed by the IWF between the reference points on the FRMCS MC service side and the GSM-R side and vice versa.

The IWF provides centralized support for interworking between an MCPTT or MCDATA system and a GSM-R system. In MCPTT or MCDATA systems, the identity of a GSM-R user is provided as an MCPTT or MCDATA ID, and the identity of a GSM-R group is provided as a MCPTT or MCDATA group ID. The identity is used by the IWF to derive the corresponding identities used in the GSM-R system and vice versa.

The IWF performs the identity mapping between an MCPTT system or MCDATA system and a GSM-R system during exchange of signalling and media messages.

The IWF acts as MCX participating function in the context of GSM-R interworking.

Figure 5.1-1 illustrates the functional model of the application plane for interworking between GSM-R, MCPTT, and MCDATA.

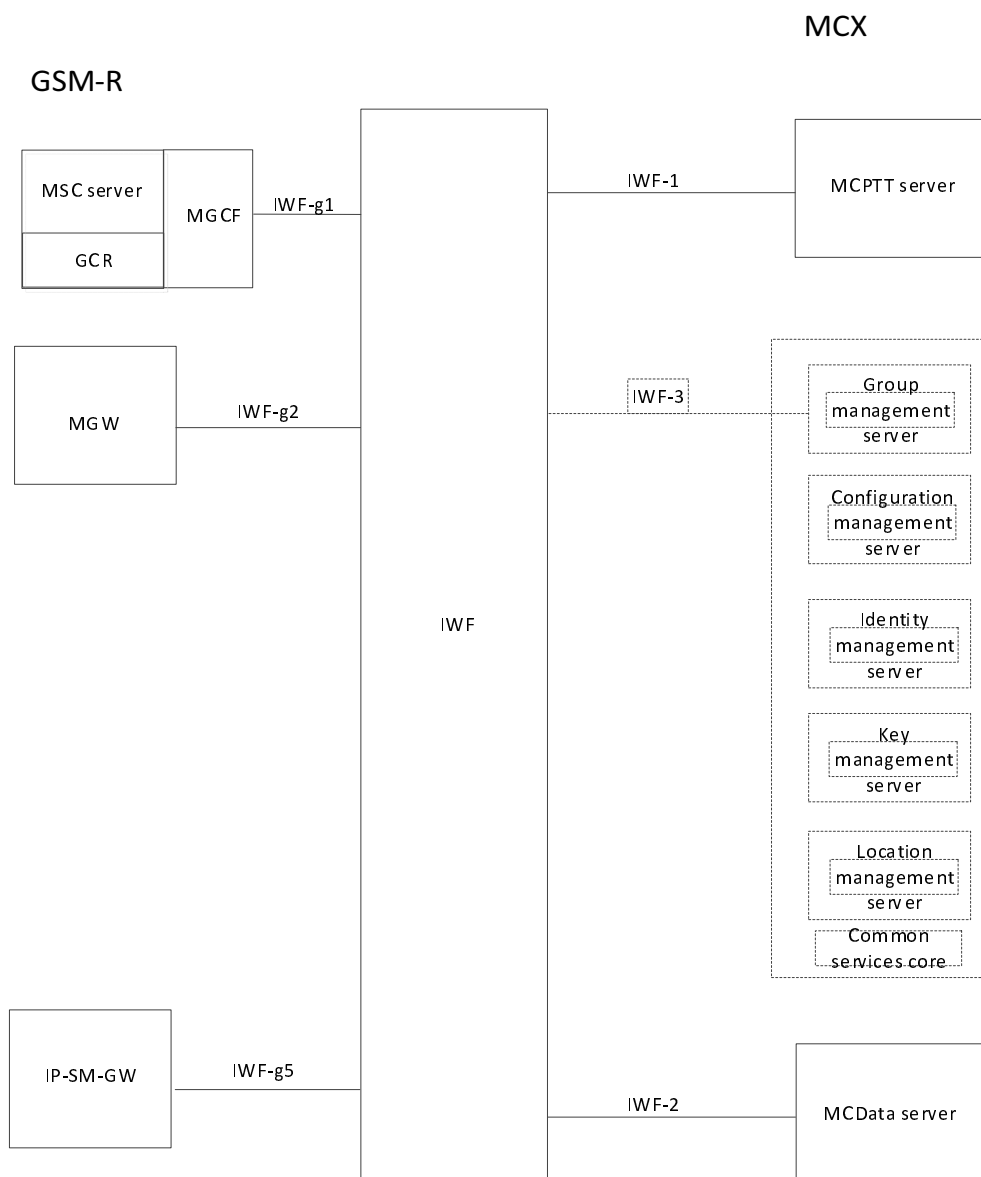

Figure 5.1-1: Interworking functional model

This model is based on ETSI TS 123 283 [11]. The protocols used at any reference point exposed for MCPTT service interoperability with a FRMCS SIP core, are to be compatible with the protocols defined for the corresponding reference point defined in ETSI TS 123 002 [i.5].

5.2 Reference points

5.2.0 General

The normative requirements placed on a FRMCS SIP Core are detailed in ETSI TS 103 765-2 [4]. The reference points only need to be derived from IMS specific reference points as shown in Table 5.2.0-1.

Table 5.2.0-1: Proposed mapping of reference points on GSM-R side according to ETSI TS 129 163 [12]

Original IMS reference point	Derived IWF-gx reference point
Mg/Mj	IWF-g1
Mb	IWF-g2
ISC	IWF-g5

5.2.1 Reference point IWF-1 (between the IWF and the MCPTT server)

The IWF-1 reference point, defined between the IWF and the MCPTT server, enables peer-to-peer interconnection between the GSM-R system and the MCPTT system. IWF-1 supports a subset of the MCPTT-3 functionalities as defined in ETSI TS 123 379 [i.6], with some differences detailed in the present document. The IWF-1 interface uses the same signalling plane protocol(s) defined for MCPTT-3. Additionally, floor control signalling and media are also transferred using the IWF-1 reference point.

5.2.2 Reference point IWF-2 (between the IWF and the MCDATA server)

The IWF-2 reference point, defined between the IWF and the MCDATA server, enables SDS interconnection between the GSM-R system and the MCDATA system. IWF-2 supports a subset of the functionalities of MCDATA-SDS-1 and MCDATA-SDS-2, as specified in ETSI TS 123 282 [i.7] with some differences as detailed in the present document. The IWF-2 interface uses the same signalling plane protocol(s) defined for MCDATA-3 except where otherwise detailed in the present document.

5.2.3 Reference point IWF-3 (between the IWF and the group management server)

The IWF-3 reference point, defined between the IWF and the group management server, would enable group management interconnection between the GSM-R system and the MC service system. IWF-3 is based upon CSC-16, as specified in ETSI TS 123 280 [i.3]. IWF-3 is not used for interworking with GSM-R.

5.2.4 Reference point IWF-g1 (between the IWF and the MSC server/MGCF)

The IWF-g1 reference point, defined between the IWF and the MSC server via MGCF, enables signalling plane for voice communication based on implementation of the reference point Mg/Mj as defined by ETSI TS 129 163 [12].

Additional information on GCR from ETSI TS 143 068 [i.8]:

"The general architecture of GSM is maintained. In addition, a network function is required which is used for registration of the group call attributes, the Group Call Register (GCR)".

The IWF has no direct interface towards the GCR.

NOTE: The GCR implementation is not specified. It is to be realized e.g. as a new network node, in a PABX directly attached to an MSC, inside an MSC or as an HLR. The interface between the GCR function and other functions is not specified in the GSM technical specifications. As a consequence, the functional split between MSC and GCR as developed in the present document is only indicative.

The GCR data for a specific voice group call is set at the creation of the group call attributes and is to be subsequently modified. No support for these functions is specified in the GSM technical specifications.

In a RANflex configuration as defined in ETSI TS 123 236 [i.9] with group call redundancy, GCRs associated to MSCs belonging to the same redundancy pool need to communicate with each other by means of SYNC_GCR messages.

5.2.5 Reference point IWF-g2 (between the IWF and MGW)

The IWF-g2 reference point, defined between the IWF and the MGW, would enable media plane protocol for voice communication.

5.2.6 Reference point IWF-g5 (between the IWF and IP-SM-GW)

The IWF-g5 reference point is defined between the IP-SM-GW on the GSM-R side and the IWF.

If SIP interfaces are used, the IP-SM-GW on the GSM-R side converts the SMPP MAP protocol to SIP (ISC).

6 Identities and addressing

6.0 General

In the present document, the IWF provides network support for interworking between FRMCS and GSM-R for voice and messaging services.

The IWF shall provide the following services:

- Routing service(s) that can manage addressing.
- Identity mapping service(s) that can manage a set of identities.

The IWF is connected with:

- MC Service Server(s) using IWF-1 and IWF-2;
- MGCF using IWF-g1; and
- IP-SM-GW using IWF-g5;

to enable those routing services and identity mapping services (besides other services of the IWF).

Clause 6 specifies the routing services and the identity mapping services of the IWF.

Clause 6 refers to address parameters by generic parameter names, as identified in Table 6.0-1:

Table 6.0-1: Used generic parameter names

Generic Parameter Name	Applicable Communication or Service
Called Address	Private Call, OIP, Messaging
Calling Address	
Additional Calling Address	
Connected Address	TIP, ECT, Conferencing
User To User Information	Presentation of FN
Call History Info	Call Diversion

NOTE: Generic parameter names are introduced for the purpose of specifying identity mapping services in clause 6.3.

The mapping between these generic address parameters and the protocol parameters at the various reference points are described in the stage 3 parts of the present document.

6.1 Identity definitions

From a logical point of view, the IWF performs an identity mapping between the FRMCS reference points IWF-1/IWF-2 and the GSM-R reference points IWF-g1/IWF-g5.

Figure 6.1-1 shows the location of the IWF between FRMCS Domains and GSM-R Domains.

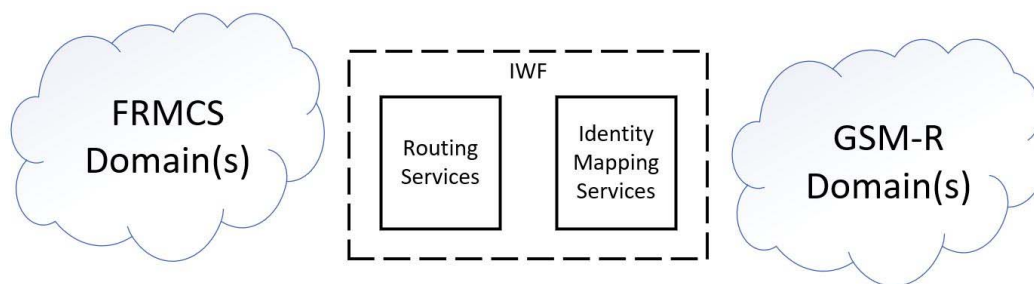

Figure 6.1-1: Domains involved in identity mapping

Identity mapping refers to the mapping of protocol address parameters during the interworking of SIP calls and SIP messages between FRMCS domain(s) (i.e. the MCPTT/MCData system and its partner MC systems) and GSM-R domain(s) (i.e. the GSM-R core and other non-MC systems).

The following identities shall be represented by protocol address parameters, at the reference points IWF-1, IWF-2, IWF-g1 and IWF-g5:

- E.164 addresses specify addresses of subscribers.
- EIRENE addresses specify addresses of railway functions.
- MC service IDs specify the addresses of MCPTT or MCData users.
- MC service group IDs specify the addresses of groups of MCPTT users.
- FAs specify addresses of railway functions and can be rephrased as EIRENE addresses.

6.2 Representation in interworking systems

E.164 SIP-R URIs and EIRENE SIP-R URIs shall be used at IWF-g1 and IWF-g5 to represent E.164 addresses and EIRENE addresses, respectively.

MCX IDs and FAs shall be used at IWF-1 and IWF-2, as defined in the 3GPP MC standards.

FA(164) and FA(EIRENE) shall be special FAs that are SIP URIs as defined in ETSI TS 103 389 [6], clause 6.3.6.

The following set of identity types defined in Table 6.2-1 shall be applicable to the IWF identity mapping service(s).

Table 6.2-1: Usage of identities at FRMCS and GSM-R reference points

Identity Type	Endpoint	Identity example
MC Service ID	IWF-1/2	'sip:alice@mcx.railway.example.at'
MC Service Group ID	IWF-1/2	'sip:grup.1900.200@mcx.railway.example.at'
FA(164)	IWF-1/2	'sip:+991471154321@mcx.railway.example.at;user=phone'
FA(EIRENE)	IWF-1/2	'sip:04371234501@mcx.railway.example.at;user=gsmr'
FA	IWF-1/2	'sip:loc-12345.Control_1@0080'
E.164 SIP-R URI	IWF-g1/g5	'sip:+991471154321@ims.railway.example.at;user=phone'
EIRENE SIP-R URI	IWF-g1/g5	'sip:04371234501@ims.railway.example.at;user=gsmr'

Clause 6.3 will describe the identity mapping by using the names of the generic address parameters. Protocol address parameters shall be referred to by the generic parameter names as defined in Tables 6.2-2 and 6.2-3.

Table 6.2-2: Mapping of generic and protocol address parameters for MCPTT

Generic Address Parameter	Protocol Parameters, as Defined in Stage 3		Applicable SIP Message
	Endpoint IWF-1	Endpoint IWF-g1	
Called Address, see note 1	<mcptt-request-uri> / <resources-list>	Request URI	INVITE request
Calling Address, see note 2	<mcptt-calling-user-id>	P-Asserted-Identity	INVITE request
Additional Calling Address, see note 3	<mcptt-calling-group-id>	From	INVITE request
Connected Address	<mcptt-called-party-id>	P-Asserted-Identity	reINVITE request UPDATE request 200 OK (INVITE)
User To User Information (PFN)	<functional-alias-URI>	User-To-User (ETSI TS 103 389 [6])	INVITE request 180 Ringing Response 200OK(INVITE) response BYE request
Call History Info	<forwarding-immediate-list> <forwarding-other-list>	History-Info (ETSI TS 103 389 [6])	INVITE request
NOTE 1: At IWF-1, the Called Address can contain an MC Service ID, an FA, an FA(164) or an FA(EIRENE). NOTE 2: At IWF-1, the Calling Address can contain an MC Service ID. NOTE 3: The Additional Calling Address is relevant, if a group communication invites either a participant or another group communication. E.g. if a GSM-R VGCS/VBS invites an MCPTT user as participant, then the MGCF will send the CT5 number of the group call as an EIRENE SIP-R URI in the From header field.			

Table 6.2-3: Mapping of generic and protocol address parameters for MCData

Generic Address Parameter	Protocol Parameters, as Defined in Stage 3		Applicable SIP Message
	Endpoint IWF-2	Endpoint IWF-g5	
Called Address, see note 1	<mcddata-request-URI>	Request URI	MESSAGE request
Calling Address, see note 2	<mcddata-calling-user-id>	P-Asserted-Identity	MESSAGE request
NOTE 1: At IWF-1, the Called Address can contain an MC Service ID, an FA, an FA(164) or an FA(EIRENE). NOTE 2: At IWF-1, the Calling Address can contain an MC Service ID.			

6.3 Identity mapping and addressing

6.3.0 General

The IWF shall perform mapping of identities between GSM-R entities and FRMCS entities. The IWF shall be configurable in such a way that enables identity mapping services to be performed.

Clause 6.3 specifies:

- IWF routing service(s).
- IWF identity mapping Service(s).

6.3.1 Management policies for identity mapping and routing

6.3.1.1 General

Within an FRMCS domain, the following provisions shall be done:

- An IWF domain shall be defined for interworking with GSM-R:
 - The IWF domain is used to indicate that call(s) may be routed to another domain by using the IWF service(s).
 - The IWF domain shall be used by the IWF, in order to indicate to FRMCS entities that an identity belongs to a GSM-R entity.

- An FRMCS domain shall be defined:
 - The default FRMCS domain shall be used by the IWF, in order to replace the domain of GSM-R to FRMCS protocol address parameters that point to FRMCS entities.

Within the FRMCS SIP Core, the following provisions shall be made:

- The IMS domain, which is configured at the FRMCS SIP Core, shall be reachable from the GSM-R domain(s).
- A configurable routing function shall be defined in such a way that:
 - Set(s) of E.164 digits or set(s) of EIRENE digits of address parameters can be assigned to set(s) of FRMCS entities.
 - Rule(s) can be applied that determine the processing of GSM-R to FRMCS address parameters for set(s) of FRMCS entities.

6.3.1.2 Examples for the changing of the domain in SIP URIs

As specified in clause 6.3.1, the IWF will change the domain of protocol address parameters, so that:

- FRMCS entities can address GSM-R entities by using the IWF Domain (which will be changed into a GSM-R Domain by the IWF).
- GSM-R entities can address FRMCS entities by using the IMS Domain (which will be changed into an FRMCS Domain by the IWF).

Figure 6.3.1.2-1 depicts an example for IWF changing the domain of SIP URIs. It uses the following abbreviations:

- CdA = Called Address
- CgA = Calling Address
- A1 Party = first example of a calling party (within a GSM-R Domain)
- A2 Party = second example of a calling party (within an FRMCS Domain)
- B Party = called party
- ims.com = IMS Domain
- mgcf.com = GSM-R Domain
- frmcs.com = FRMCS Domain
- iwf.com = IWF Domain

NOTE: The user parameter ("user=gsmr", "user=phone") is omitted in the SIP URIs, for the sake of brevity.

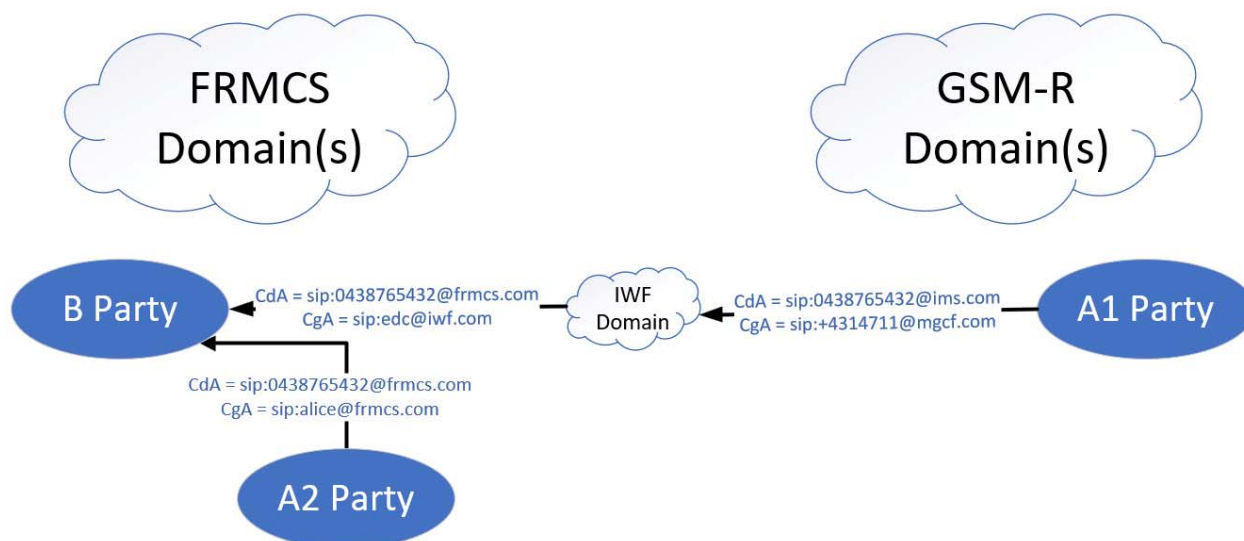

Figure 6.3.1.2-1: Example for IWF changing the domain of SIP URIs

NOTE: Figure 6.3.1.2-1 shows only the domain mapping for an FA(EIRENE) as a Called Address and for two alphanumeric MCPTT IDs as Calling Addresses, because the focus of this example is on the domain changing. Some more complete examples might be added in a later version.

6.3.2 SIP routing services

6.3.2.1 GSM-R to FRMCS out-of-dialog SIP requests

GSM-R to FRMCS out-of-dialog SIP requests are out-of-dialog SIP requests that are routed from a GSM-R domain to a FRMCS domain by the IWF.

For the purpose(s) of the present document, the following list applies to routing of GSM-R to FRMCS out-of-dialog SIP request(s):

- Any out-of-dialog SIP request received at the IMS domain that originates from a GSM-R domain shall be routed by the IWF routing service(s) to an MC service server using IWF-1 or IWF-2, if this is not forbidden by operator policy.
- If the forwarding of a GSM-R to FRMCS out-of-dialog SIP request to an MC service server using IWF-1 or IWF-2 is forbidden by operator policy, then the SIP request shall be rejected with a "403 MCX Interworking Forbidden" final SIP response.
- Any provisions for routing service(s) regarding forwarding of GSM-R to FRMCS out-of-dialog SIP requests to non-FRMCS domain(s) are out of scope.

6.3.2.2 FRMCS to GSM-R out-of-dialog SIP requests

FRMCS to GSM-R out-of-dialog SIP requests are out-of-dialog SIP requests that are routed from a FRMCS domain to a GSM-R domain by the IWF.

For the purpose(s) of the present document, the following list applies to the routing of FRMCS to GSM-R out-of-dialog SIP request(s):

- Any FRMCS to GSM-R out-of-dialog SIP INVITE request shall be routed by the IWF routing service(s) to a GSM-R MGCF using IWF-g1.
- Any FRMCS to GSM-R out-of-dialog SIP MESSAGE request shall be routed by the IWF routing service(s) to a GSM-R IP-SM-GW using IWF-g5.

- Any provisions for routing service(s) regarding forwarding of FRMCS to GSM-R out-of-dialog SIP requests to non-FRMCS domain(s) are out of scope.

6.3.3 Identity mapping services

6.3.3.0 General

The IWF identity mapping service(s) shall provide mapping of the following types of identities, and also considering group call criteria:

- MC Service ID.
- FA.
- Group Call Criteria.
- MC Service Group ID.

Mapping of MC Service ID provides identity mapping between MC Service ID and SIP-R URI.

Mapping of FA provides identity mapping between FA(164), FA(EIRENE) or FA and SIP-R URI.

6.3.3.1 Generic procedures for identity mapping

6.3.3.1.0 General

A set of address parameters are subject to a generic identity mapping as specified within this clause.

The first decision of generic identity mapping is to determine if the address parameters of a SIP/SDP message are subject to a GSM-R to FRMCS domain transition or subject to a FRMCS to GSM-R domain transition. Based on this decision, the appropriate procedure described in either clause 6.3.3.1.1 or 6.3.3.1.2 shall be applied.

NOTE: The decision about whether the SIP message is being forwarded from FRMCS to GSM-R or vice versa, can be done based on the incoming interface: if the message is received via IWF-g1 or IWF-g5, then the interworking is from GSM-R to FRMCS, if the message is received via IWF-1 or IWF-2, then the interworking is from FRMCS to GSM-R.

6.3.3.1.1 Generic identity mapping for GSM-R to FRMCS SIP messages

For the case of a GSM-R to FRMCS interworking (as defined in clause 6.3.3.1.0) and for each SIP/SDP address parameter subject to generic identity mapping, the following processing steps shall be applied:

NOTE: For the case of mapping of GSM-R to FRMCS addresses, the set of addresses subject to mapping can be one of the types: E.164 SIP-R URI or EIRENE SIP-R URI.

1) Configurable Routing Function

The analysis part of the routing function determines if the address parameter identifies an FRMCS entity or a GSM-R entity.

2) FRMCS Entity

For FRMCS entities, the configurable routing function shall deliver an indication of the type of how the identity mapping services shall handle the input SIP-R URI when mapping it to a concrete address parameter valid in the FRMCS domain.

The identity mapping service(s) shall map the input SIP-R URI into:

- MC Service ID; or
- FA(164); or
- FA(EIRENE); or

- FA.

Means for protocol address parameter mapping may be locally hosted.

If the content of the address parameter is mapped to an FA(164), to an FA(EIRENE), or to an FA, then the domain part of the resulting SIP URI shall be set to the FRMCS domain.

3) GSM-R Entity

For GSM-R entities, one of the following protocol address mappings are applicable:

- E.164 SIP-R URI shall be mapped to FA(164).
- EIRENE SIP-R URI shall be mapped to FA(EIRENE).

The domain part of the resulting SIP URI shall be set to an IWF domain.

6.3.3.1.2 Generic identity mapping for FRMCS to GSM-R SIP messages

For SIP messages received by an IWF from an FRMCS domain that have a GSM-R domain as destination (as defined in clause 6.3.3.1.0) and for each protocol address parameter subject to generic identity mapping, one of the following processing steps shall be applied to these parameter(s):

1) MC Service ID

If the address parameter contains an MC Service ID, then it shall be mapped to an E.164 SIP-R URI or to an EIRENE SIP-R URI, depending on the indication provided by the configurable routing function.

2) E.164 Address

If the address parameter carries an FA(164), then it shall be mapped to an E.164 SIP-R URI. The domain of the resulting SIP-R URI shall be set to the IMS domain.

3) EIRENE Address or FA

If the address parameter carries an FA(EIRENE) or an FA, then it shall be mapped to an EIRENE SIP-R URI. The domain of the resulting SIP-R URI shall be set to the IMS domain.

6.3.3.2 Mapping of basic address parameters for MCPTT private calls

6.3.3.2.0 General

The set of basic address parameters applicable for private calls using MCPTT, applying generic address parameter naming as defined in clause 6.2 are:

- Called Address.
- Calling Address.
- Additional Calling Address.
- Connected Address.

The above set of basic address parameters shall be mapped according to clause 6.3.3.2.

The Called Address shall, following the mapping according to clause 6.3.3.2, be used by IWF routing service(s) to determine the next destination endpoint for a SIP INVITE to an MCPTT private call dialog.

NOTE 1: Called Address, Calling Address and Additional Calling Address are applicable to SIP INVITE message(s) that initiates a MCPTT Private Call dialog.

NOTE 2: Connected Address is applicable to a successful response (200 OK) to a request that initiates a MCPTT private Call dialog.

NOTE 3: The set of basic address parameters mentioned above covers functional aliases in the called address, but it does not cover functional aliases in the calling address (except EIRENE addresses and FAs in the additional calling address for group communication). The mapping of calling functional aliases (PFN) is not considered a mapping of "basic" addresses and it is covered in clause 6.3.3.4.1.

6.3.3.2.1 Basic address parameters for GSM-R to FRMCS private calls

For any request detected within the IWF domain for a GSM-R to FRMCS private MCPTT call that is received from a GSM-R domain, analysis as specified in clause 6.3.3.1.1 for the Called Address shall be performed to determine if the MCPTT private call is intended to be established in a FRMCS domain.

If the call is not intended to be established, the call shall be rejected by a final and non-successful SIP response.

If the call is intended to be established in a FRMCS domain, the following list of steps is applicable:

- 1) Identity mapping on Called Address (based on indicative result as given by procedure(s) in clause 6.3.3.1.1) shall be applied as specified in Table 6.3.3.2.1-1.

Table 6.3.3.2.1-1: Cases of mapping of Called Address for GSM-R to FRMCS private calls

Type of Address	Called Address at IWF-g1	Called Address at IWF-1
MC Service ID	E.164 SIP-R URI	MC Service ID (e.g. by local address lookup)
FA(164)	E.164 SIP-R URI	FA(164)
FA(EIRENE)	E.164 or EIRENE SIP-R URI	FA(EIRENE)
FA	E.164 or EIRENE SIP-R URI	FA

NOTE: The Type of Address for FRMCS entities is asserted by the configurable routing function as specified in clause 6.3.3.1.1, bullet 2. FRMCS Entity.

- 2) If identity mapping on Called Address based on Table 6.3.3.2.1-1 results to FA(164), FA(EIRENE) or FA, the domain part of a resulting SIP URI for Called Address shall be set to a FRMCS domain.
- 3) The Calling Address shall be used for identity mapping as specified in Table 6.3.3.2.1-2.

Table 6.3.3.2.1-2: Cases of mapping of Calling Address for GSM-R to FRMCS private calls

Calling Address at IWF-g1	Calling Address at IWF-1
E.164 SIP-R URI	FA(164) from Calling Address

The domain part of a resulting SIP URI for Calling Address shall be set to a IWF domain.

- 4) If Connected Address is present and is populated with data in a SIP response message from a FRMCS domain that indicates successful setup of dialog (SIP 200 OK), the Connected Address shall be used for identity mapping as specified in Table 6.3.3.2.1-3.

Table 6.3.3.2.1-3: Cases of mapping of Connected Address for GSM-R to FRMCS private calls

Connected Address at IWF-1	Connected Address at IWF-g1
MC Service ID	E.164 SIP-R URI (e.g. by local address lookup)
FA(164)	E.164 SIP-R URI
FA(EIRENE) or FA	EIRENE SIP-R URI

- 5) The domain part of a resulting SIP URI for Connected Address shall be set to a IMS domain if the Connected Address was previously mapped from FA(164), FA(EIRENE) or FA as part of an initial SIP dialog request (SIP INVITE).

6.3.3.2.2 Basic address parameters for FRMCS to GSM-R private calls

If the request for an MCPTT private call is forwarded by the IWF from an FRMCS domain to another domain, then the IWF shall apply one of the following identity mappings to the Called Address, as defined in Table 6.3.3.2.2-1, before the routing services of the IWF take any routing decision.

Table 6.3.3.2.2-1: Cases of mapping of Called Address and Calling Address for FRMCS to GSM-R private calls

Called/Calling Address at IWF-1	Called/Calling Address at IWF-g1
MC Service ID	E.164 or EIRENE SIP-R URI (e.g. by local address lookup)
FA(164) see note	E.164 SIP-R URI
FA(EIRENE) or FA (see note)	EIRENE SIP-R URI
NOTE: The Called Address can contain MC Service ID, FA, FA(164) or FA(EIRENE), the Calling Address can only contain MC Service ID. If the resulting Called Address was mapped from an FA(164), from an FA(EIRENE) or from an FA, then the domain of the resulting SIP URI needs to be retrieved and then set as specified at ETSI TS 123 228 [7], clause 4.3.5.	

The routing decisions may result in the fact that the call request may be looped back via the IWF to a FRMCS domain, as described in clause 6.3.3.2.1, after all of the identity mappings of the FRMCS to GSM-R call request as defined in clause 6.3.3.2.2 will have been done.

Also, if the request for an MCPTT private call is forwarded by the IWF from a FRMCS domain to a GSM-R domain, then the IWF shall apply the identity mapping to the Calling Address as defined in Table 6.3.3.2.2-1.

The domain of the resulting SIP URI shall be set to the IMS domain.

The final SIP 200 OK response to the call request can contain a Connected Address.

If the final SIP 200 OK response to the call is received from another domain and if it contains a Connected Address, then the IWF shall apply one of the following identity mappings to the Connected Address, as defined in Table 6.3.3.2.2-2.

Table 6.3.3.2.2-2: Cases of mapping of Connected Address for FRMCS to GSM-R private calls

Connected Address at IWF-g1	Connected Address at IWF-1
E.164 SIP-R URI	FA(164)
EIRENE SIP-R URI	FA(EIRENE)

The domain of the resulting SIP URI shall be set to the IWF domain.

6.3.3.3 Identity mapping for MCDData SDS

6.3.3.3.0 General

The IWF will receive the Text Message from the GSM-R IP-SM-GW and map it to the MCDData SDS.

In the reverse direction the IWF will map the MCDATA SDS to an Instant Message and send it to the GSM-R IP-SM-GW.

The set of basic address parameters applicable for text messaging using MCDData SDS, also applying generic address parameter naming as defined in clause 6.2 are:

- Called Address.
- Calling Address.

The Called Address shall, following the mapping according to clause 6.3.3.3, be used by IWF routing service(s) to determine the next destination endpoint for a SIP MESSAGE.

6.3.3.3.1 Address parameters for GSM-R to FRMCS text messages

For any request detected within the IWF domain for a GSM-R to FRMCS Text Message that is received from a GSM-R domain, analysis as specified in clause 6.3.3.1.1 for the Called Address shall be performed to determine if the Instant Message is intended to be delivered to an FRMCS domain.

If the text message is not intended to be delivered, it shall be rejected by a final and non-successful SIP response.

If the text message is intended to be delivered to an FRMCS domain, the following list of steps is applicable:

- 1) Identity mapping on Called Address (based on indicative result as given by procedure(s) in clause 6.3.3.1.1) shall be applied as specified in Table 6.3.3.3.1-1.

Table 6.3.3.3.1-1: Cases of mapping of Called Address for GSM-R to FRMCS text message

Type of Address	Called Address at IWF-g5	Called Address at IWF-2
MC Service ID	E.164 SIP-R URI	MC Service ID (e.g. by local address lookup)
FA(164)	E.164 SIP-R URI	FA(164)
FA(EIRENE)	E.164 or EIRENE SIP-R URI	FA(EIRENE)
FA	E.164 or EIRENE SIP-R URI	FA

NOTE: The Type of Address for FRMCS entities is asserted by the configurable routing function. For details, refer to the definition provided in clause 6.3.3.1.1, bullet 2. FRMCS Entity.

- 2) If identity mapping on Called Address based on Table 6.3.3.3.1-1 results to FA(164), FA(EIRENE) or FA, the domain part of a resulting SIP URI for Called Address shall be set to a FRMCS domain.
- 3) The Calling Address shall be used for identity mapping as specified in Table 6.3.3.3.1-2.

Table 6.3.3.3.1-2: Mapping of Calling Address for GSM-R to FRMCS text message

Calling Address at IWF-g5	Calling Address at IWF-2
E.164 SIP-R URI	FA(164) from Calling Address

The domain part of a resulting SIP URI for Calling Address shall be set to an IWF domain.

6.3.3.3.2 Address parameters for FRMCS to GSM-R text messages

If the request for an MCDATA SDS message is forwarded by the IWF from an FRMCS domain to a GSM-R domain, then the IWF shall apply one of the following identity mappings to the Called Address, as defined in Table 6.3.3.3.2-1, before the routing services of the IWF take any routing decision.

Table 6.3.3.3.2-1: Cases of mapping of Called Address and Calling Address for FRMCS to GSM-R text messages

Called/Calling Address at IWF-2	Called/Calling Address at IWF-g5
MC Service ID	E.164 or EIRENE SIP-R URI (e.g. by local address lookup)
FA(164)	E.164 SIP-R URI
FA(EIRENE) or FA	EIRENE SIP-R URI

If the resulting Called Address was mapped from an FA(164), from an FA(EIRENE) or from an FA, then the domain of the resulting SIP URI shall be retrieved and then set as specified in ETSI TS 123 228 [7], clause 4.3.5.

The routing decisions may result in the loop back of the text message to a FRMCS domain via the IWF, as described in clause 6.3.3.3.1. This occurs after completing all identity mappings between the FRMCS and the GSM-R systems.

Also, if the request for an MCPTT text message is forwarded by the IWF from a FRMCS domain to GSM-R domain, then the IWF shall apply one of the identity mappings to the Calling Address, as defined in Table 6.3.3.3.2-1.

The domain of the resulting SIP URI shall be set to the IMS domain.

6.3.3.4 Identity mapping for supplementary services

6.3.3.4.0 General

The identity mapping services of the IWF shall be applicable to the interworking of supplementary services, whenever supplementary identity (address) information is exchanged between an FRMCS domain and a GSM-R domain.

Explicitly listed, these supplementary identities are:

- MCPTT functional aliases and GSM-R functional numbers, when handling the PFN service.
- Call history information - i.e. a list of all forwarded identities - in the case of call diversion.
- Mutual exchange of connected identities, in the case of call transfer.
- Information about all connected identities, in the case of group calls.

6.3.3.4.1 Presentation of Functional Number - User To User Information

The mapping of Basic Address Parameters (see clause 6.3.3.2) covers MCPTT IDs and MCDATA IDs in the Called Address parameter and functional aliases (FRMCS FA, FA(164), FA(EIRENE)).

The Calling Address is supposed to always carry MCPTT IDs or MCDATA IDs on the IWF-1 reference point (e.g. in the XML element <mcptt-calling-user-id>) and E.164 SIP-R URIs on the IWF-g1 reference point (in the P-Asserted-Identity header field).

The Additional Calling Address for group communication carries an FRMCS FA or an FA(EIRENE) on the IWF-1 reference point and an equivalent CT5x EIRENE FN in a SIP-R URI on the IWF-g1 reference point.

A possible calling functional alias, and its equivalent EIRENE FN will be carried in the User To User Information (PFN), which is the <functional-alias-URI> on IWF-1 and the User-to-User header field on IWF-g1.

GSM-R Functional Numbers (FNs) carried in the User-to-User header field shall be interworked with FRMCS in one of the following two ways:

- A GSM-R FN can be rephrased as FRMCS FA and vice versa as specified in FRMCS FRS [1] and FRMCS SRS [2].
- A GSM-R FN can be mapped to an FA(EIRENE) and vice versa.

In both cases, the FRMCS identity shall be carried in the <functional-alias-URI> element of the MCPTT-INFO XML body.

In the second case, GSM-R FNs can be mapped to FA(EIRENE) (but not rephrased as FRMCS FA). This shall be accomplished by just taking the FN as the user part of the resulting SIP URI. The domain of the resulting SIP URI shall be set to the IWF domain.

If an FA(EIRENE) is mapped to an FN, this shall be accomplished by taking the user part of the SIP URI as an international address, which is then used in the SIP User-to-User header field.

The User-to-User header field shall be forwarded transparently from the FRMCS domain to the GSM-R domain and vice versa, as the User-to-User header field can contain more information as just an FN/FA, e.g. CHPC information, GPS, etc.

The mapping from GSM-R FN to FRMCS FA (or FA(EIRENE)) shall be done additionally, as described above, by adding the <functional-alias-URI> XML element.

If a SIP message is forwarded from the FRMCS domain to the GSM-R domain, and if the User-to-User header field is not present, then the IWF shall perform the mapping from FRMCS FA (or FA(EIRENE)) to GSM-R FN and create a User-to-User header field that contains a GSM-R FN.

NOTE: A GSM-R FN can be carried in the User-to-User header field in one of two different formats: a) with the help of a PFN tag b) as uncompressed OTDI.

6.3.3.4.2 Call Diversion - Call History Address List

The Call History Address List is transmitted as follows:

- At the IWF-g1 reference point, the call history information shall be transmitted within History-Info header fields, according to ETSI TS 103 389 [6].

- At the IWF-1 reference point, the call history information shall be transmitted within the <forwarding-immediate-list> and within the <forwarding-other-list>, according to ETSI TS 124 379 [10].

The address parameters in the History-Info header fields of GSM-R to FRMCS messages and the address parameters in the <forwarding-immediate-list> and in the <forwarding-other-list> of FRMCS to GSM-R messages shall be applied to the generic procedures for identity mapping according to clause 6.3.3.1.

The reason for call forwarding shall be mapped between the "cause" URI parameter at the IWF-g1 reference point and the <forwarding-reason> element at the IWF-1 reference point, as defined in Tables 6.3.3.4.2-1 and 6.3.3.4.2-2.

Table 6.3.3.4.2-1: Mapping of the Forwarding Reason for FRMCS to GSM-R messages

Forwarding Reason at IWF-1	Forwarding Reason at IWF-g1
Immediate	480 - default
No-answer	408
Manual-input	487

Table 6.3.3.4.2-2: Mapping of the Forwarding Reason for GSM-R to FRMCS messages

Forwarding Reason at IWF-g1	Forwarding Reason at IWF-1
404 (Unknown/Not available)	no-answer (<forwarding-other-list>) - default
486 (User busy)	no-answer (<forwarding-other-list>)
408 (No reply)	no-answer (<forwarding-other-list>)
302 (Unconditional)	immediate (<forwarding-immediate-list>)
487 (Deflection during alerting)	manual-input (<forwarding-other-list>)
480 (Deflection immediate response)	immediate (<forwarding-immediate-list>)
503 (Mobile subscriber not reachable)	no-answer (<forwarding-other-list>)

6.3.3.4.3 Explicit Call Transfer - Connected Address

The Connected Addresses transmitted during the execution of a call transfer service shall be mapped according to the description of generic identity mapping in clause 6.3.3.1.

6.3.3.5 Mapping of Identities, Criteria and Domains for MCPTT group calls

6.3.3.5.0 General

MCPTT Group Calls are group calls that are controlled by the Controlling Function of an MCPTT Server beyond the IWF-1 reference point, as seen from the IWF.

As described in clause 7, MCPTT Ad-Hoc Group calls can be coupled with GSM-R VGCS/VBS calls, where either the MCPTT Group call invites an MCPTT ID as participant that represents any called GSM-R VGCS/VBS at the IWF, or the GSM-R VGCS/VBS invites an E.164 SIP-R URI or an EIRENE SIP-R URI that represents any MCPTT Ad-Hoc group call at the IWF.

During the setup of such coupled FRMCS/GSM-R group calls, the IWF maps the FRMCS Criteria (of the ad-hoc group call) into a GSM-R CT5 Functional Number or vice versa, as shown in Figure 6.3.3.5.0-1 and defined in clause 6.3.3.5.2.

This mechanism is sketched in Figure 6.3.3.5.0-1.



Figure 6.3.3.5.0-1: Coupled FRMCS/GSM-R Group Call

The Group Call Representation (GCRep) used at the IWF-1 reference point shall be configured as MCPTT ID of a participant of the ad-hoc group call at the MC Service Server and at the IWF.

The Group Call Representation (GCRep) used at the IWF-g1 reference point shall be configured either as an international E.164 address or as an international EIRENE number, corresponding to the originating or terminating dispatcher at both the GCR and at the IWF.

The term FRMCS to GSM-R group call is used in clause 6.3.3.5 to describe the SIP dialog that is established by an MCPTT group call, when the group call invites a GSM-R VGCS/VBS call via the IWF.

The term GSM-R to FRMCS group call is used in clause 6.3.3.5 to describe the SIP dialog that is established by a GSM-R VGCS/VBS call via the IWF, in order to create an MCPTT group call.

6.3.3.5.1 Mapping of basic address parameters for MCPTT group calls

The content of Called Address and Calling Address at the IWF-1 and IWF-g1 reference points is specified in Tables 6.3.3.5.1-1 and 6.3.3.5.1-2.

Table 6.3.3.5.1-1: Content of basic address parameters during the setup of FRMCS to GSM-R group calls

Address Parameter	Content at IWF-1	Content at IWF-g1
Called Address	GCRep (an MCPTT ID)	EIRENE CT5 SIP-R URI
Criteria	Criteria for determining the participants	n/a
Calling Address	MC Service ID	E.164 SIP-R URI (e.g. by local address lookup)

Table 6.3.3.5.1-2: Content of basic address parameters during the setup of GSM-R to FRMCS group calls

Address Parameter	Content at IWF-g1	Content at IWF-1
Called Address	GCRep (E.164 SIP-R URI or EIRENE SIP-R URI)	n/a
Criteria	n/a	Criteria for determining the participants
Calling Address	E.164 SIP-R URI	MC Service ID (e.g. by local address lookup)
Additional Calling Address	EIRENE CT5 SIP-R URI	FA(EIRENE)

6.3.3.5.2 Mapping of FRMCS criteria and EIRENE CT5 FN

The MCPTT call control protocol, defined in ETSI TS 124 379 [10] specifies the criteria for determining the participants, that an MCPTT UE shall send when initiating an ad-hoc group call.

These criteria are transmitted in the <call-participants-criterias> element in the <anyExt> element of the <mcptt-Params> element of the <mcpttinfo> element of the application/vnd.3gpp.mcpttinfo+xml MIME body in the SIP INVITE request.

The content of these criteria is just a string with comma separated parameters, where the parameters are defined in the FRMCS FIS [3] specification.

The specification in the FRMCS FIS [3] considers that the criteria will be mapped to and from an EIRENE CT5 Functional Number at the IWF, as follows:

- An EIRENE CT5 international number is specified as IC + CT + LLLLL + GID, where:
 - IC International Code (3 digits).
 - CT Calltype (2 digits).
 - LLLLL Group Call Area (5 digits).
 - GID Group ID (3 digits).

- FRMCS FIS specifies the following criteria relevant for the mapping to and from an EIRENE CT5 FN:
 - FRMCS_CallType (string).
 - FRMCS_ListOfAdressedArea (string).

The mapping identified in Table 6.3.3.5.2-1 shall apply for the setup of coupled FRMCS/GSM-R group calls.

Table 6.3.3.5.2-1: Mapping of FRMCS criteria and EIRENE CT5 for coupled FRMCS/GSM-R group calls

Parameter at IWF-g1 Part of the EIRENE CT5 FN	Parameter at IWF-1 Part of the FRMCS Criteria
IC	Group Call Representation (domain)
CT, GID	FRMCS_CallType
LLLLL	FRMCS_ListOfAdressedArea

7 Group calls

7.1 Interworking procedures

7.1.0 General

This clause contains stage 2 and stage 3 procedures for interworking of group calls between 3GPP MCPTT systems and GSM-R systems.

The messages and information elements used in the procedures in this clause are specified in the following documents:

- ETSI TS 103 389 [6] for GSM-R.
- ETSI TS 123 283 [11] for MCPTT stage 2.
- ETSI TS 129 379 [8] and ETSI TS 124 379 [10] for MCPTT stage 3.

Figure 7.1.0-1 illustrates an interworking scenario with an area that has is commonly used by GSM-R and FRMCS users as base scenario for the information flows and procedures in the following clauses.

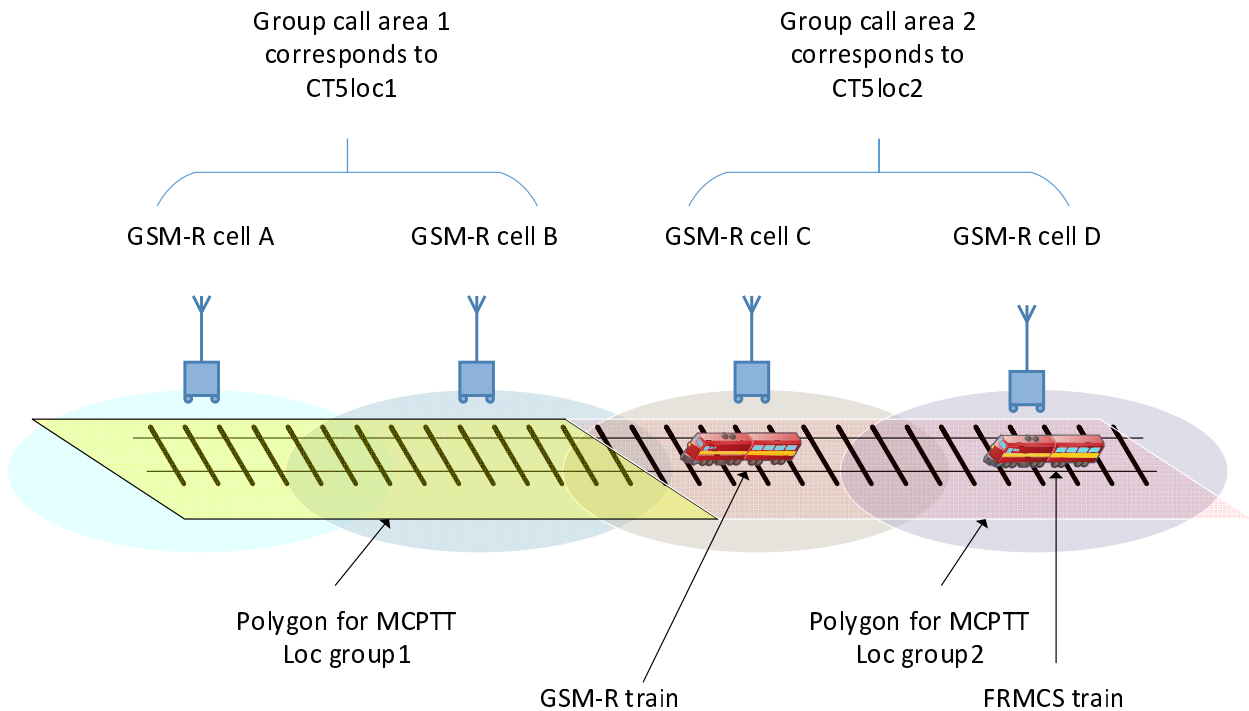

Figure 7.1.0-1: Network overview

If a group call is initiated by a train driver that is connected to the FRMCS domain, the call will be initiated in the respective FRMCS area (MCPTT Loc group1 or MCPTT Loc group2) and the call has to trigger and include also the corresponding VGCS group call reference number (GCref) according to E.164 numbering plan using EIRENE numbering scheme in GSM-R (CT5loc1 or CT5loc2). Similar if a group call is initiated by a train driver that is connected to the GSM-R domain, the call has to trigger and include also the corresponding MCPTT group call in FRMCS. The following clauses define these two procedures in more detail.

7.1.1 Information flows

7.1.1.1 Stage 2 information flows

7.1.1.1.1 General

This clause introduces the stage 2 information flows related to the interworking of group calls between MCPTT and GSM-R:

- The SIP interface between the MGCF and the IWF is based on implementation of the reference point Mg/Mj as defined by ETSI TS 129 163 [12] and extended by parts of ETSI TS 103 389 [6].
- IWF ringing is defined in ETSI TS 123 283 [11], clause 10.4.1.4.
- IWF MCPTT ad-hoc group call request is defined in ETSI TS 123 283 [i.13] with the following clarification:
 - The parameter Criteria for determining the participants shall be set according to clause 6.3.3.5.2 of the present document.
 - The parameter Requested priority shall be set according to ETSI TS 103 765-2 [4].
 - The parameter Additional application specific data shall be set according to clause 6.3.3.4.1 of the present document.
- IWF MCPTT ad-hoc group call response is defined in ETSI TS 123 283 [i.13].

7.1.1.1.2 IWF GSM-R IWF ad-hoc group call request

Table 7.1.1.1.2-1 contains the GSM-R IWF group call request information flow.

Table 7.1.1.1.2-1: GSM-R IWF group call request

Information Element	Status	Description
Called Address	M	SIP Request-URI, as defined in clause 6.3.3.5. This information element can hold an E.164 SIP-R URI or an EIRENE SIP-R URI, as defined in ETSI TS 103 389 [6].
Calling Address	M	P-Asserted-Identity, as defined in clause 6.3.3.5. This information element can hold an E.164 SIP-R URI, as defined in ETSI TS 103 389 [6].
Additional Calling Address	O	From header field, as defined in clause 6.3.3.5. This information element is considered being present, when the From header field contains an EIRENE SIP-R URI.
Resource Priority	M	The Resource-Priority header field, as defined in ETSI TS 103 389 [6].
User to User Information	O	This information element may contain user to user information, e.g. a calling GSM-R functional number for the PFN service (see clause 6). This information element is specified in ETSI TS 103 389 [6].

7.1.1.1.3 IWF GSM-R IWF ad-hoc group call response

Table 7.1.1.1.3-1 contains the GSM-R IWF group call response information flow.

Table 7.1.1.1.3-1: GSM-R IWF group call response

Information Element	Status	Description
Connected Address	O	P-Asserted-Identity, as defined in clause 6.3.3.5. This information element can hold an E.164 SIP-R URI or an EIR+ENE SIP-R URI, as defined in ETSI TS 103 389 [6].
User to User Information	O	This information element may contain user to user information, e.g. a called GSM-R functional number for the PFN service (see clause 6). This information element is specified in ETSI TS 103 389 [6].

7.1.1.2 Stage 3 Information flows

For IWF GSM-R group call requests the following shall apply:

- For calls from GSM-R to FRMCS: GSM-R VGCS/VBS including a terminating dispatcher representing a group on the FRMCS domain (e.g. CT5 FN) - referenced as terminating dispatcher in the GCR - parameters shall be mapped as follows:
 - E.164 calling party in PAI (ETSI TS 129 163 [12]);
 - CT5 FN in From Header (ETSI TS 103 389 [6]);
 - calling OTDI in User-To-User hdr (ETSI TS 103 389 [6]).
- For calls from FRMCS to GSM-R: FRMCS adhoc group call including an MCPTT user representing the GSM-R group (CT5 VGCS/VBS) as terminating user, parameters shall be mapped as follows:
 - E.164 calling party in PAI (ETSI TS 129 163 [12]);
 - CT5 FN in From Header (ETSI TS 103 389 [6]);
 - calling OTDI in User-To-User hdr (ETSI TS 103 389 [6]).
- From the point of view of the SIP trunk between the IWF and the MGCF, the connection between the MCPTT group call and the GSM-R group call shall be performed as a point-to-point call with two-way audio connection.

For IWF GSM-R group call response the following shall apply:

SIP 200 (OK) according to ETSI TS 103 389 [6]. For further details see GSM-R IWF Group Call Response information flow in clause 7.1.1.1.

This message is based on the SIP INVITE request for MCPTT adhoc group call as defined in ETSI TS 124 379 [10].

For IWF MCPTT adhoc group call request the following shall apply:

This message is based on the SIP INVITE request for MCPTT adhoc group call as defined in ETSI TS 124 379 [10].

For IWF MCPTT adhoc group call response the following shall apply:

This message is based on the SIP 200 (OK) request for MCPTT adhoc group call as defined in ETSI TS 124 379 [10].

7.2 Group call principles

7.2.1 Group call initiated by a GSM-R user

7.2.1.1 Group call initiated by a GSM-R user interacting with MCPTT group call

7.2.1.1.1 Stage 2 procedure

Pre-conditions:

- 1) The Group Call Register (GCR) of the GSM-R system contains an additional entry under terminating dispatchers for a user on the IWF that represents the location defined group on the MCPTT system.

Figure 7.2.1.1.1-1 illustrates the procedure for a group call initiated by a GSM-R user interacting with an MCPTT group call.

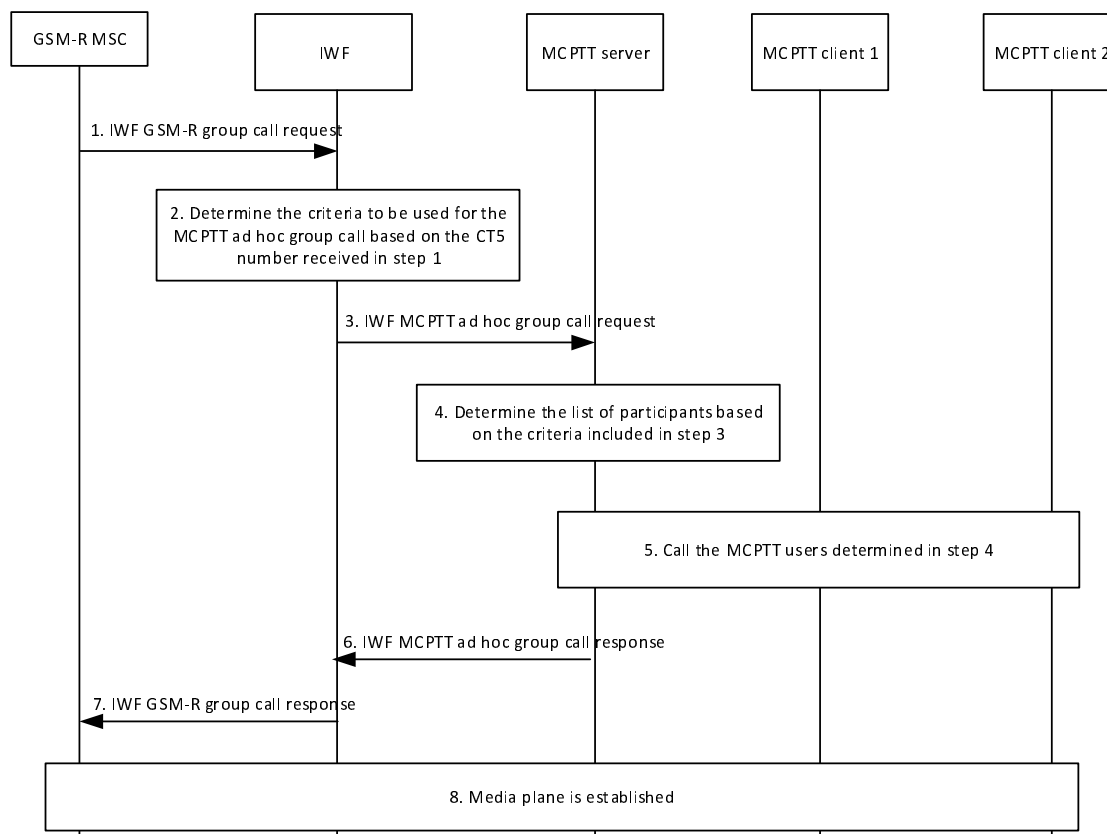

Figure 7.2.1.1.1-1: Group call initiated by GSM-R user interacting with MCPTT group call

The procedure shall be as follows:

1. The procedure shall be as follows: Triggered by a group call in GSM-R the GSM-R system sends a GSM-R IWF group call request to the IWF.
2. Based on the CT5 FN received in step 1 the IWF determines the criteria to be used in the ad-hoc group call.

NOTE 1: An international EIRENE CT 5 number has the following format: IC+50/1+SSSSS+GID. The format of the criteria for the ad-hoc group call used by FRMCS is defined in FRMCS FIS-7970 [3]. The IWF generates the criteria based on the location part (SSSSS) and the GID part of the EIRENE CT5 FN. For REC for example, GID 299 is mapped to a criteria with the value of group call type that represents REC. GID 200 is mapped to a criteria with the value of group call type that represents "all trains in area" Then GSM-R location part SSSSS is mapped to the corresponding value for location in FRMCS. The GSM-R calltype 50 is mapped to a normal ad-hoc group call in MCPTT, while the calltype 51 is mapped to a broadcast call.

3. The IWF shall send an IWF MCPTT adhoc group call request to the MCPTT server.
4. The MCPTT server determines the list of users to be included based on the criteria included in the IWF MCPTT adhoc group call request in step 3.
5. The MCPTT server sends individual MCPTT adhoc group call requests to all concerned MCPTT users.
6. The MCPTT server sends a IWF MCPTT adhoc group call response to the IWF.
7. The IWF shall send a IWF GSM-R group call response to the GSM-R system.
8. The media plane between all concerned users in the MCPTT system and in the GSM-R system is established. The link between the two systems is established as two-way channel. i.e. the group calls are linked with a two-way speech channel which is always open for talking/listening.

NOTE 2: The handling of talker control is described in clause 7.2.5, and the handling of mute and unmute is described in clause 7.2.6.

7.2.1.1.2 Stage 3 procedure

Pre-conditions:

- 1) The Group Call Register (GCR) of the GSM-R system contains an additional entry under terminating dispatchers for a user on the IWF that represents the location defined group on the MCPTT system.
- 2) The MCPTT server has location criteria defined that can be used to determine the users of an ad-hoc group call.

Figure 7.2.1.1.2-1 illustrates the procedure for a group call initiated by a GSM-R user interacting with an MCPTT group call.

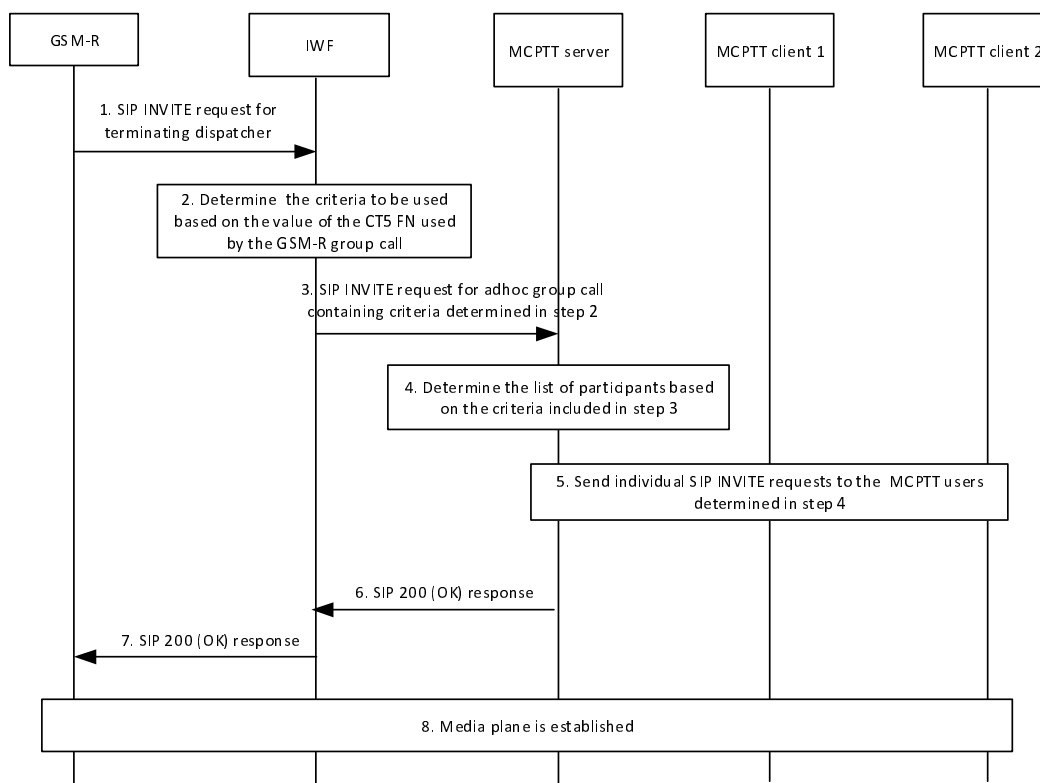

Figure 7.2.1.1.2-1: Group call initiated by GSM-R user interacting with MCPTT group call

The procedure shall be as follows:

1. Triggered by a group call in GSM-R the GSM-R system sends a SIP INVITE request towards the IWF as defined in ETSI TS 103 389 [6] with the request URI set to the value of the terminating dispatcher corresponding to the matching MCPTT group.

NOTE 1: From GSM-R perspective it is a terminating dispatcher having a special function to act as logical entry for a group call in MCPTT.

2. The IWF determines the criteria to be used for the ad-hoc group call based on the value of the GSM-R group GCRef (international EIRENE CT5 FN) contained in the SIP From header.

NOTE 2: An international EIRENE CT 5 number has the following format: IC+50/1+SSSSS+GID. The format of the criteria for the ad-hoc group calls used by FRMCS is defined in FRMCS FIS-7970 [3]. The IWF generates the criteria based on the location part (SSSSS) and the GID part of the EIRENE CT5 FN. For REC for example, GID 299 is mapped to a criteria with the value of group call type that represents REC. GID 200 is mapped to a criteria with the value of group call type that represents "all trains in area". Then GSM-R location part SSSSS is mapped to the corresponding value for location in FRMCS. The GSM-R calltype 50 is mapped to a normal ad-hoc group call in MCPTT, while the calltype 51 is mapped to a broadcast call, indicated by the <broadcast-ind> element present with a value of "true".

NOTE 3: The criteria used in FRMCS are defined in the FRMCS FIS-7970 [3].

NOTE 4: The IWF performs the mapping of the international CT5 EIRENE number and the criteria to be used in the MCPTT system according to clause 6.

3. The IWF sends a SIP INVITE request for an MCPTT adhoc group call to the MCPTT server, that contains the criteria as determined in step 2.

A Resource-Priority header field is added, set to "normal priority" mcptt.x value, x=0 (as defined in IETF RFC 8101 [5]). In addition the <user-requested-priority> field shall be added, set according to the Communication Session Category to an mcptt.x value, x=0 to 15, based on the received GSM-R Call Priority and depending on the priority mapping between GSM-R and MCPTT.

The emergency flag and the imminent peril flag shall not be set by the IWF.

4. The MCPTT server determines the list of users to be included based on the criteria and local policy.
5. The MCPTT server sends individual SIP INVITE requests for MCPTT adhoc group call to all concerned MCPTT users.
6. The MCPTT server sends a SIP 200 (OK) response to the IWF.
7. The IWF sends a-SIP 200 (OK) response to the GSM-R system.
8. The media plane between all concerned users in the MCPTT system and in the GSM-R system is established. The link between the two systems is established as two-way channel i.e. the group calls are linked with a two-way speech channel which is always open for talking/listening.

NOTE 5: The handling of talker control is described in clause 7.2.5, and the handling of mute and unmute is described in clause 7.2.6.

7.2.2 Group call initiated by an MCPTT user

7.2.2.1 Group call setup initiated by MCPTT user interacting with the GSM-R system

7.2.2.1.1 Stage 2 procedure

Pre-conditions:

- 1) The configuration on the MCPTT server for the criteria used in the adhoc group call contains an additional entry with an MCPTT ID that represents CT5 numbers on the GSM-R system.
- 2) The IWF contains configuration data containing the value of an MCPTT ID used for the interworking of adhoc group calls with group calls on the GSM-R system. When it receives an adhoc group call request targeted to the MCPTT ID that is configured on the IWF for the interworking of adhoc group calls, the IWF derives the CT5 number based on the criteria received in the adhoc group call request.
- 3) The group call register (GCR) of the GSM-R system contains an additional entry under originating dispatchers that has the same value as the originating ID (MSISDN or FN) sent in the request from the IWF to trigger the group call in the GSM-R system in step 9.

NOTE 1: This entry is required to authenticate the Dispatcher Leg on GSM-R GCR and allow group call establishment.

Figure 7.2.2.1.1-1 illustrates the procedure for a group call initiated by an MCPTT user interacting with an GSM-R group call.

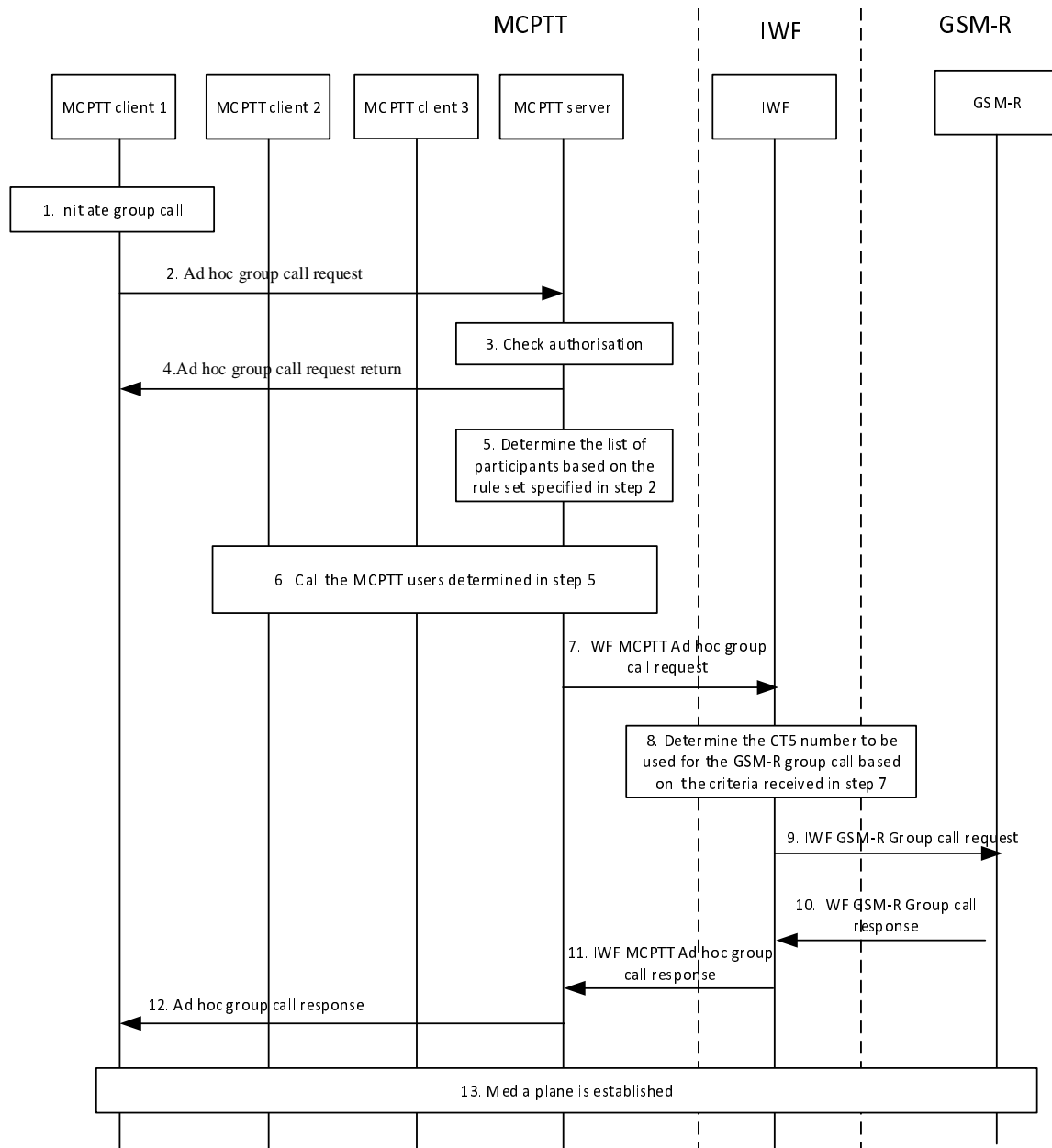

Figure 7.2.2.1.1-1: Group call setup initiated by MCPTT user interacting with GSM-R group call

The procedure shall be as follows:

1. The user at MCPTT client 1 initiates an adhoc group call to a group that is involving a GSM-R system.
2. The MCPTT client 1 sends an adhoc group call request containing the details of the criteria to be applied by the MCPTT server.
3. The MCPTT server receives the adhoc group call request and checks if the adhoc group call is supported and authorized.
4. The MCPTT server sends an adhoc group call request return message to MCPTT client 1 containing the following information elements:
 - i) the MCPTT adhoc group ID generated by the MCPTT server;
 - ii) the group ID of the pre-configured group to be used for the adhoc group call (only included if the adhoc group call is authorized); and
 - iii) result of whether the adhoc group call is authorized or not.

If the adhoc group call request is not authorized, the MCPTT server and client 1 does not proceed with the rest of the steps.

5. The MCPTT server determines the list of users to be included in the adhoc group call.

NOTE 2: Based on the criteria provided in step 2 and based on configuration within the MCPTT server, the MCPTT server determines an MCPTT user representing the GSM-R group to be included in the adhoc group call.

NOTE 3: The list of users determined at step 5 will not contain additional MCPTT users representing a GSM-R group to avoid chained group calls and loops.

6. The MCPTT server sends individual MCPTT adhoc group call requests to all MCPTT users determined in step 5.
7. The MCPTT server sends an IWF MCPTT adhoc group call request to the IWF inviting the MCPTT user represented by the GSM-R group determined in step 5.
8. Based on the criteria received in step 7 and based on configuration within the IWF, the IWF determines the CT5 FN to be used in the subsequent group call request towards GSM-R.

NOTE 4: The format of the criteria for the ad-hoc group calls used by FRMCS is defined in FRMCS FIS-7970 [3]. An international EIRENE CT5 number has the following format: IC+50/1+SSSSS+GID. The IWF generates the CT5 FN to be used for the group call in GSM-R by deriving the location portion SSSSS from the location part of the criteria, and the GID from the group call type part of the criteria. The GSM-R calltype 50 or 51 is determined depending on the presence of a <broadcast-ind> element present with a value of "true".

9. The IWF sends an IWF GSM-R group call request to the GSM-R system.
10. The GSM-R system sends an IWF GSM-R group call response to the IWF.
11. The IWF sends an IWF adhoc group call response to the MCPTT server.
12. The MCPTT server sends an adhoc group call response to MCPTT client 1.
13. The media plane between all concerned users in the MCPTT system and in the GSM-R system is established. The link between the two systems is established as two-way channel i.e. the group calls are linked with a two-way speech channel which is always open for talking/listening.

NOTE 5: The handling of talker control is described in clause 7.2.5, and the handling of mute and unmute is described in clause 7.2.6.

7.2.2.1.2 Stage 3 procedure

Pre-conditions:

- 1) The configuration on the MCPTT server for the criteria used in the adhoc group call contains an additional entry with an MCPTT user representing the corresponding CT5 number in GSM-R.
- 2) The IWF contains a configuration containing the value of an MCPTT ID representing the groups on the GSM-R system. When it receives a SIP INVITE request targeting the MCPTT ID that is configured on the IWF, the IWF shall derive the CT5 number based on the criteria received in the SIP INVITE request.
- 3) The Group Call Register (GCR) of the GSM-R system contains an additional entry under originating dispatchers that has the same value as the originating ID (MSISDN or FN) sent in the request from the IWF to trigger the group call in the GSM-R system in step 9.

Figure 7.2.2.1.2-1 illustrates the procedure for a group call initiated by an MCPTT user interacting with a GSM-R group call.

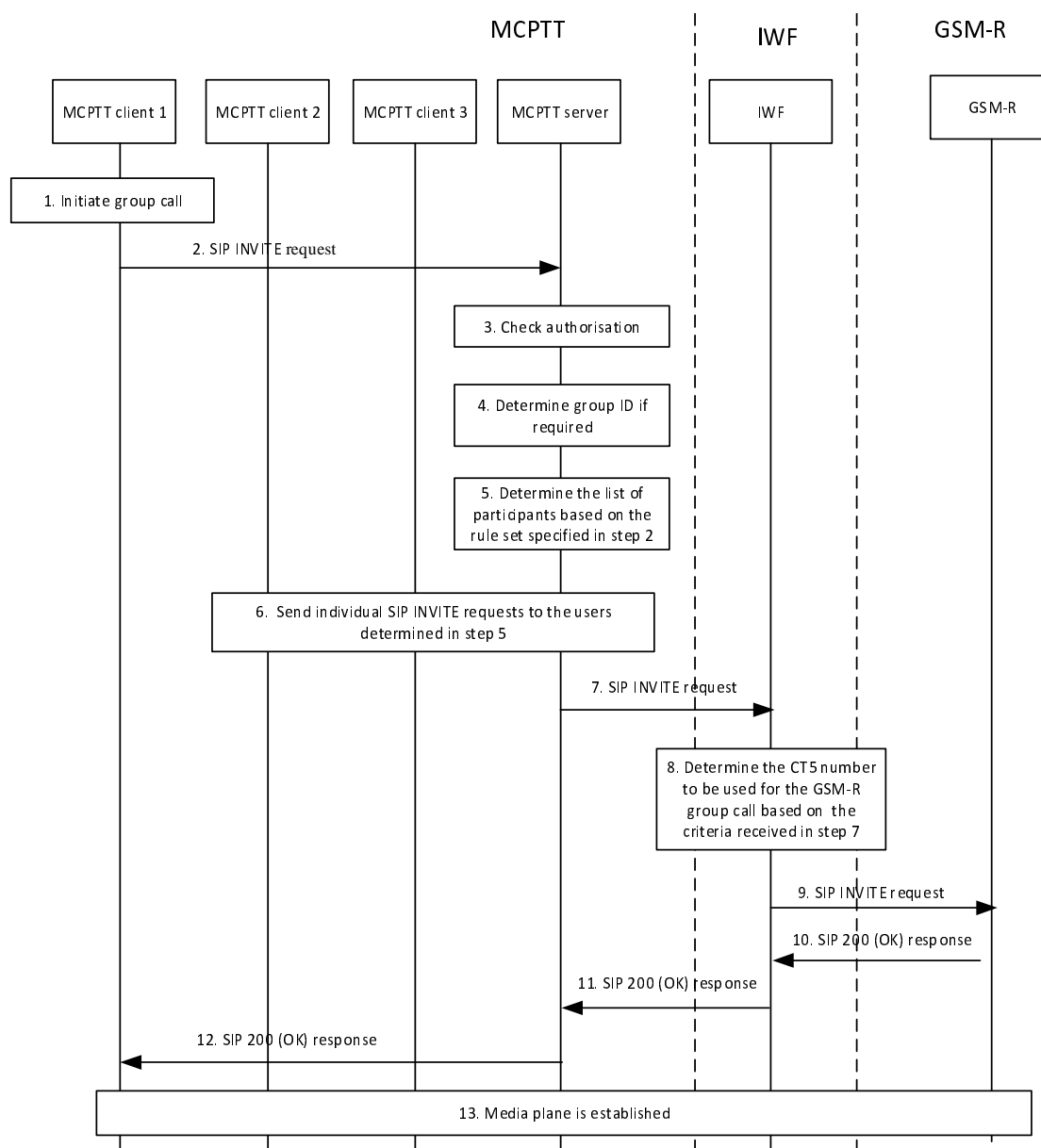

Figure 7.2.2.1.2-1: Group call setup initiated by MCPTT user interacting with GSM-R group call

The procedure shall be as follows:

1. The user at MCPTT client 1 initiates an adhoc group call to a group that is involving a GSM-R system.
2. The MCPTT client 1 sends a SIP INVITE request for adhoc group call request according to ETSI TS 124 379 [10] containing the details of the criteria to be applied by the MCPTT server.
3. The MCPTT server accepts the adhoc group call request checks if the adhoc group call is supported and authorized.
4. According to the conditions required in ETSI TS 124 379 [10], the MCPTT server generates a group ID to be used for the adhoc group call. Otherwise, the group ID included in the SIP INVITE request from step 2 is used.
5. The MCPTT server determines the list of users to be included in the adhoc group call.

NOTE 1: Based on the criteria provided in step 2 and based on configuration within the MCPTT server, the MCPTT server determines an MCPTT user representing the GSM-R group to be included in the adhoc group call. Additionally, the list of users to be included typically contain MCPTT users matching the criteria and may also include terminating GSM-R dispatchers.

6. The MCPTT server sends individual MCPTT adhoc group call requests to all MCPTT users determined in step 5.
7. The MCPTT server sends a SIP INVITE request for an MCPTT adhoc group call towards the IWF for the MCPTT user representing the GSM-R group determined in step 5.
8. Based on the criteria received in step 7 and based on configuration within the IWF, the IWF determines the CT5 FN to be used in the subsequent group call request towards GSM-R.

NOTE 2: The format of the criteria for the ad-hoc group calls is defined in FRMCS FIS-7970 [3]. An international EIRENE CT 5 number has the following format: IC+50/1+SSSSS+GID. The IWF generates the CT5 FN to be used for the group call in GSM-R by deriving the location portion SSSSS from the location part of the criteria, and the GID from the group call type part of the criteria. The GSM-R calltype 50 or 51 is determined depending on the presence of a <broadcast-ind> element present with a value of "true".

9. The IWF sends a SIP INVITE request according to ETSI TS 103 389 [6] towards the GSM-R system for the CT5 FN to be used in the GSM-R system according to clause 6 to the GSM-R system.
10. The GSM-R system sends a SIP 200 (OK) response according to ETSI TS 103 389 [6] to the IWF.
11. The IWF sends a SIP 200 (OK) response to the MCPTT server.
12. The MCPTT server sends a SIP 200 (OK) response to MCPTT client 1.
13. The media plane between all concerned users in the MCPTT system and in the GSM-R system is established. The link between the two systems is established as two-way channel. i.e. the group calls are linked with a two-way speech channel which is always open for talking/listening.

NOTE 3: The handling of talker control is described in clause 7.2.5, and the handling of mute and unmute is described in clause 7.2.6.

7.2.3 Late entry

7.2.3.1 Late entry of an MCPTT user

7.2.3.1.1 Stage 2 procedure

Pre-conditions:

- 1) An active group call involving the MCPTT users at MCPTT client 1 and client 2 on the MCPTT system and users on the GSM-R system is in place.

Figure 7.2.3.1.1-1 illustrates the procedure for late joining of an MCPTT user into an ongoing group call already established between the MCPTT system and the GSM-R system.

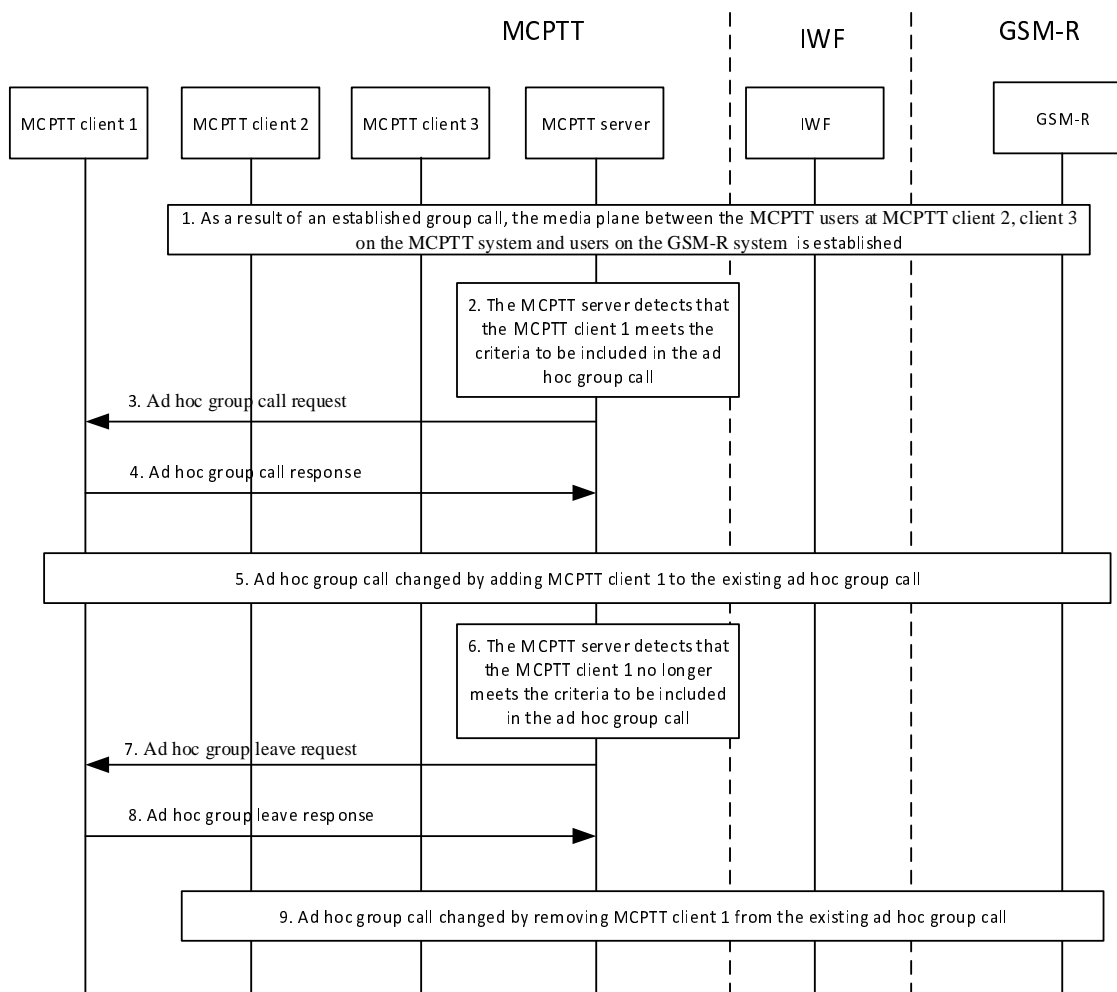

Figure 7.2.3.1.1-1: Late call entry of an MCPTT user on an interworking group defined in MCPTT system

The procedure shall be as follows:

- As a result of a previously initiated group call, an adhoc group call is established between the MCPTT client 2 and MCPTT client 3 and the GSM-R system.
- The MCPTT server detects that the MCPTT client 1 starts to meet the criteria to be included in the adhoc group call.
- The MCPTT server sends an adhoc group call request to MCPTT client 1.
- The MCPTT client 1 sends an adhoc group call response to the MCPTT server.
- As a result, the adhoc group call is changed and the MCPTT client 1 is added to the ongoing MCPTT adhoc group call.
- The MCPTT server detects that the MCPTT client 1 no longer meets the criteria to be included in the adhoc group call.
- The MCPTT server sends an adhoc group leave request to MCPTT client 1.
- The MCPTT client 1 sends an adhoc group leave response to the MCPTT server.
- As a result, the adhoc group call is changed and the MCPTT client 1 is removed from the ongoing MCPTT adhoc group call.

NOTE: For late entry of MCPTT users no interaction with GSM-R is required.

7.2.3.1.2 Stage 3 procedure

No impact on existing stage 3 procedures.

7.2.3.2 Late entry of a GSM-R user

7.2.3.2.1 Stage 2 procedure

Pre-conditions:

- 1) An active group call involving the MCPTT users at MCPTT client 1 and client 2 on the MCPTT system and users on the GSM-R system is in place.

Figure 7.2.3.2.1-1 illustrates the procedure for late joining of an MCPTT user into an ongoing group call already established between the MCPTT system and the GSM-R system.

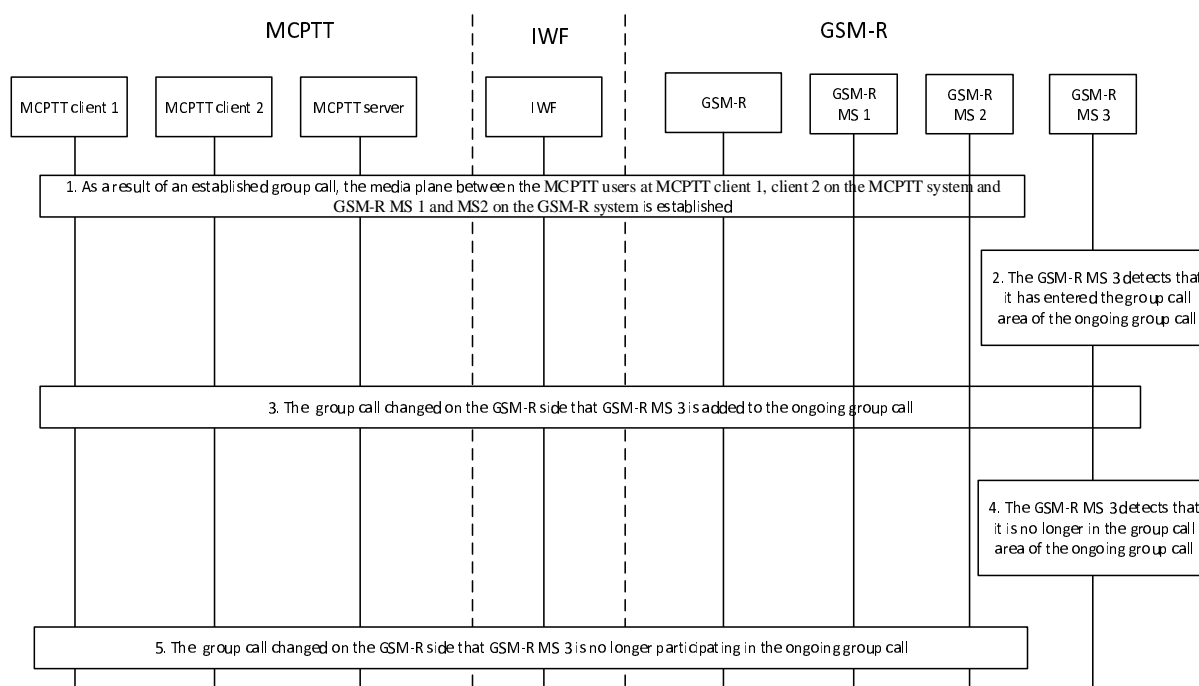

Figure 7.2.3.2.1-1: Late call entry of an GSM-R user on an interworking group defined in GSM-R system

The procedure shall be as follows:

1. As a result of a previously initiated group call, an adhoc group call is established between the MCPTT client 1, MCPTT client 2, and GSM-R MS 1 and GSM-R MS 2 on the GSM-R system.
2. The GSM-R MS 3 detects that it has entered the group call area of the ongoing group call.
3. As a result, the group in GSM-R is changed and the GSM-R MS 3 is added to the ongoing group call.
4. The GSM-R MS 3 detects that it is no longer in the group call area of the ongoing group call.
5. As a result, the group in GSM-R is changed and the GSM-R MS 3 is removed to the ongoing group call.

NOTE 1: Leaving and joining of dispatchers are as well handled purely internally in the GSM-R system.

NOTE 2: For late entry of GSM-R users and leaving and joining of dispatchers no interaction with MCPTT is required.

7.2.3.2.2 Stage 3 procedure

No impact on existing stage 3 procedures.

7.2.4 Group call release

7.2.4.1 General

Group calls can be released by various means:

- In GSM-R this can be, for example, by an authorized dispatcher sending a kill sequence, or by timer expiry. Irrespective how the group call is released, each participating user connected via SIP trunk receives a SIP BYE message.
- MCPTT group calls can be released due to various conditions, like timer expiry, where (unlike GSM-R) each participating user receives a SIP BYE message.

The procedure for group call release is to release the complete group call when a condition to release the group call in one system (MCPTT or GSM-R) is fulfilled.

NOTE: The no activity timers run on each system independently, and if one of them expires the whole call is released. Therefore, it might be necessary to increase the value.

7.2.4.2 Group call release initiated from the GSM-R side

7.2.4.2.1 Procedure

Pre-conditions:

- 1) An active group call involving the MCPTT users at MCPTT client 1 and client 2 on the MCPTT system and users on the GSM-R system is in place.

Figure 7.2.4.2.1-1 illustrates the procedure for releasing a group call from the GSM-R side.

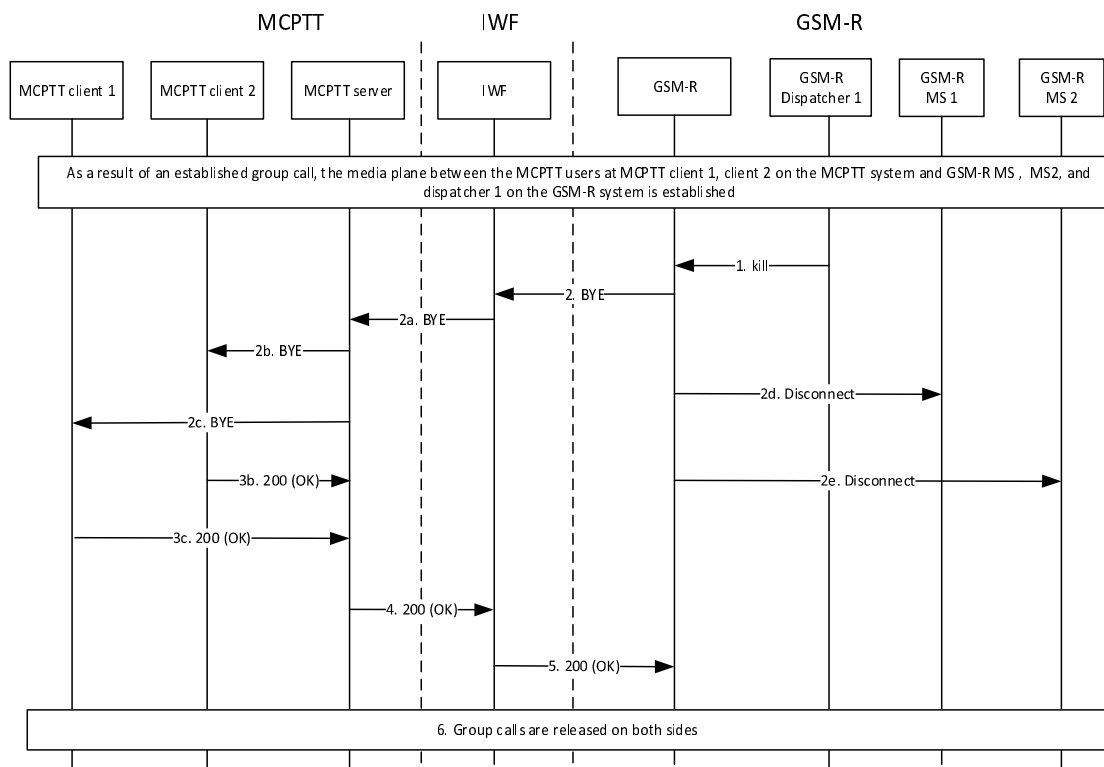

Figure 7.2.4.2.1-1: Group call released from GSM-R side

The procedure shall be as follows:

1. GSM-R Dispatcher 1 wants to release the group call and sends a kill message towards the GSM-R MSC.
 2. The GSM-R MSC sends a SIP BYE messages towards all users connected via fixed line (including the IWF), and sends messages towards the mobile users.
 - 2a. The IWF shall send a SIP BYE message towards the MCPTT server.
 - 2b-c. The MCPTT server sends SIP BYE messages towards all participants of the MCPTT group call.
- NOTE: Based on session release policy the MCPTT server releases the adhoc group call if a user with a specific MCPTT ID (the user representing the GSM-R leg of the call) leaves the call.
- 2d-e. The GSM-R MSC sends disconnect messages towards the GSM-R mobile users.
 - 3b-c. The MCPTT clients 1 and 2 respond with a SIP 200 (OK) to the MCPTT server.
 4. The MCPTT server respond with a SIP 200 (OK) to the IWF.
 5. The GSM-R MSC sends Disconnect messages towards all GSM-R mobile users of the GSM-R group call.
 6. The group call is released in MCPTT and in GSM-R.

7.2.4.3 Group call release initiated from the MCPTT side

7.2.4.3.1 Procedure

Pre-conditions:

- 1) An active group call involving the MCPTT users at MCPTT client 1 and client 2 on the MCPTT system and users on the GSM-R system is in place.

Figure 7.2.4.3.1-1 illustrates the procedure for releasing a group call from the MCPTT side.

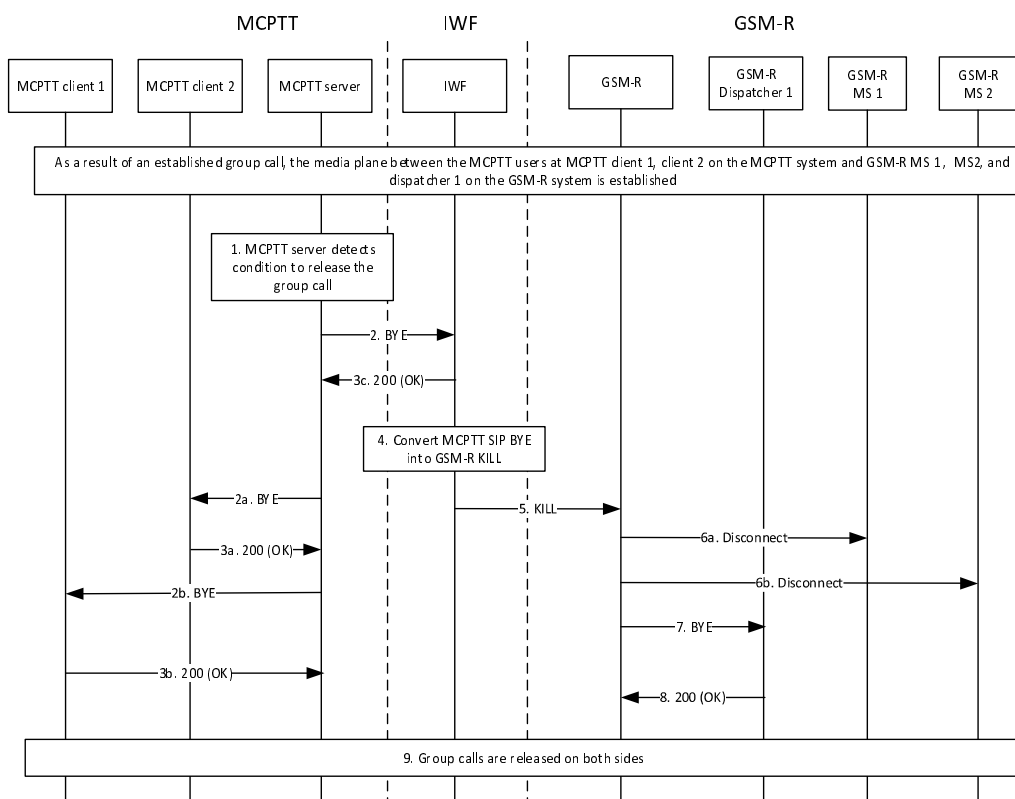

Figure 7.2.4.3.1-1: Group call released from MCPTT side

The procedure shall be as follows:

1. The MCPTT server detects a condition to release the group call.
2. The MCPTT server sends a BYE message towards the IWF.
- 2a-b. The MCPTT server sends BYE messages towards the MCPTT clients of the other MCPTT users.
- 3a-b. The MCPTT clients of the other MCPTT users respond with a SIP 200 (OK) response.
- 3c. The IWF responds with a SIP 200 (OK) response.
4. The IWF converts the MCPTT SIP BYE into a GSM-R KILL.
5. The IWF sends a KILL message using explicit signalling according to ETSI TS 103 389 [6] towards the GSM-R MSC.
- 6a-b. The GSM-R MSC sends Disconnect messages towards all mobile GSM-R mobile users of the GSM-R group call.
7. The GSM-R MSC sends a SIP BYE message towards the dispatcher connected via fixed line.
8. The fixed line dispatcher responds with a SIP 200 (OK) response.
9. The group call is released in MCPTT and in GSM-R.

7.2.5 Talker control

7.2.5.1 General

In GSM-R, talker control procedures depend on the type of user requesting to talk. This clause covers talker control for mobile users (called service subscribers), which is done by uplink control procedures. Uplink control operations in GSM-R have no impact on the MCPTT side hence also no impact on the IWF (see ETSI TR 103 768 [i.1]). Dispatchers connected via fixed line networks can talk at any time. However, to ensure that a service subscriber that has the uplink granted hears the audio of the dispatcher talking, the dispatcher unmutes the downlink when talking. Mute/Unmute is discussed in clause 7.2.6. Figure 7.2.5.2-1 illustrates the procedure.

NOTE: Mute-Unmute indication is required only in case 1 channel mode is used on GSM-R side.

7.2.5.2 Talker control operation initiated from the GSM-R side

7.2.5.2.1 Procedure

Pre-conditions:

- 1) An active group call involving the MCPTT users at MCPTT client 1 and client 2 on the MCPTT system and users on the GSM-R system is in place.

Figure 7.2.5.2.1-1 illustrates the procedure for talker control from the GSM-R side.

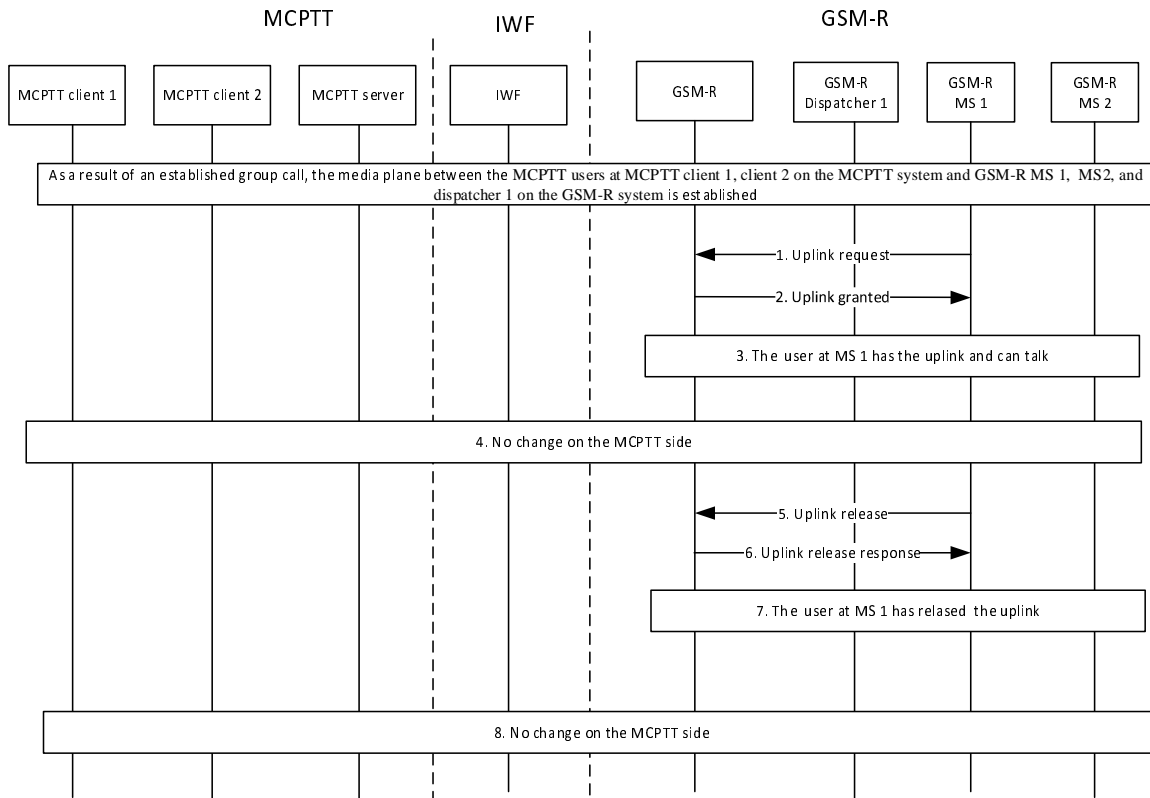

Figure 7.2.5.2.1-1: Talker control from GSM-R side

The procedure shall be as follows:

1. GSM-R Mobile user at MS 1 wants to talk and requests the uplink.
2. GSM-R Mobile user at MS 1 gets the uplink.
3. GSM-R Mobile user at MS 1 has the uplink and can talk.
4. No impact on the MCPTT side.
5. GSM-R Mobile user at MS 1 releases the uplink.
6. GSM-R Mobile user at MS 1 gets a release response message.
7. GSM-R Mobile user at MS 1 has released the uplink and cannot talk any more.
8. No impact on the MCPTT side.

NOTE: For floor control operations performed within GSM-R no interaction with MCPTT is required.

7.2.5.3 Talker control operation initiated from the MCPTT side

7.2.5.3.1 Procedure

Pre-conditions:

- 1) An active group call involving the MCPTT users at MCPTT client 1 and client 2 on the MCPTT system and users on the GSM-R system is in place.

In MCPTT talker control is done for both dispatchers and other users in the same way. Figure 7.2.5.3-1 illustrates the conclusion agreed in ETSI TR 103 768 [i.1]. The main principle is that if any user in MCPTT has the floor, the IWF is aware of that and sends an "Unmute" message towards GSM-R to make sure a service subscriber that has the uplink can

hear the audio from the MCPTT side. If the floor is released on the MCPTT side, the IWF is also aware of that and sends a "Mute" message towards GSM-R to mute the downlink of the service subscriber to avoid unnecessary echo.

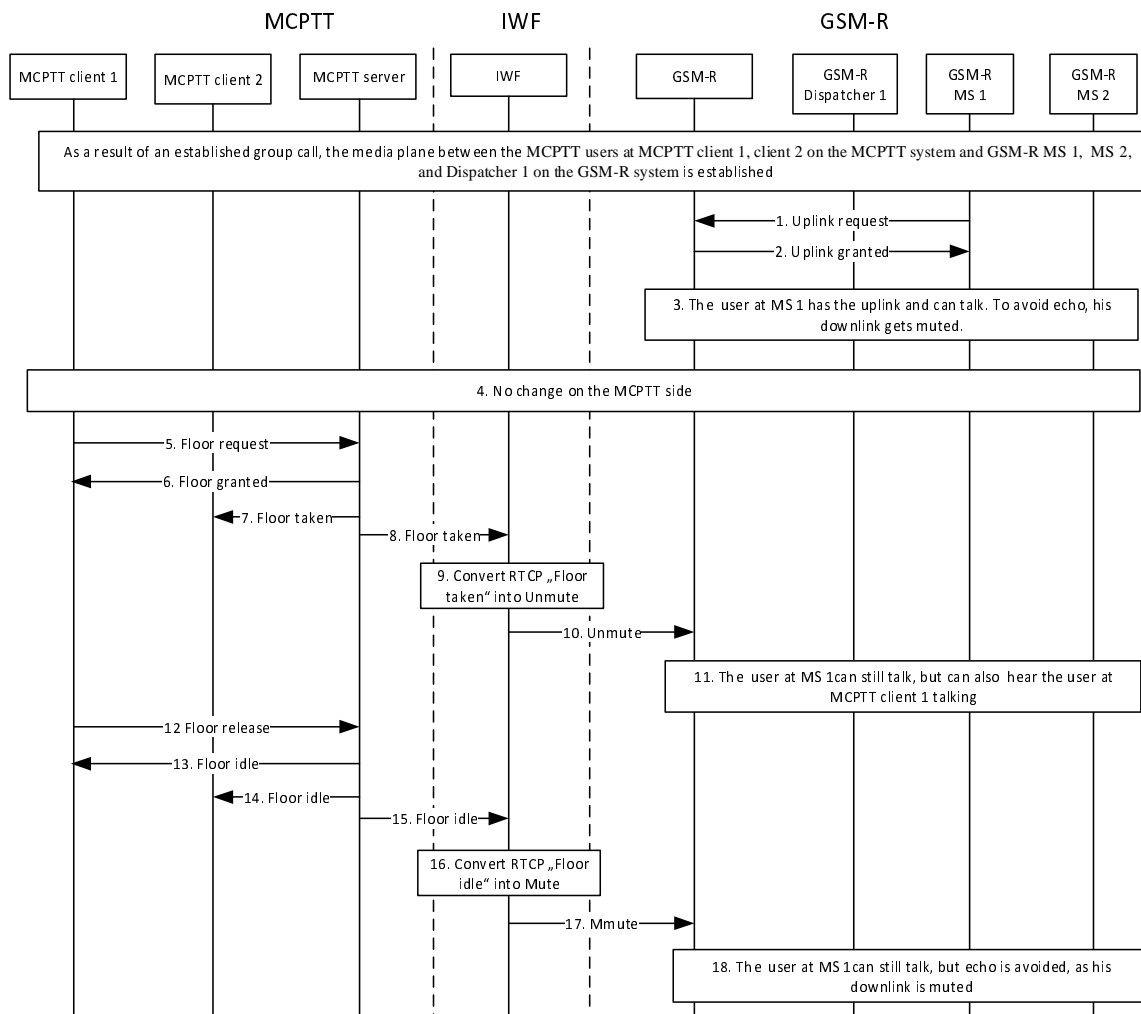

Figure 7.2.5.3-1: Talker control from MCPTT side

The procedure shall be as follows:

1. GSM-R Mobile user at MS 1 wants to talk and requests the uplink.
2. GSM-R Mobile user at MS 1 gets the uplink.
3. GSM-R Mobile user at MS 1 has the uplink and can talk. To avoid echo, his downlink is muted.
4. No impact on the MCPTT side.
5. MCPTT user at client 1 wants to talk and requests the floor.
6. MCPTT user at client 1 receives a floor granted message and gets the floor.
7. The MCPTT server sends a floor taken message towards MCPTT client 2.
8. The MCPTT server sends a floor taken message towards the IWF.
9. The IWF converts the RTCP floor taken message received from MCPTT into a GSM-R Unmute message.
10. The IWF sends an Unmute message using explicit signalling according to ETSI TS 103 389 [6] towards the GSM-R MSC.
11. The downlink of the GSM-R user at MS 1 is unmuted. GSM-R Mobile user at MS 1 can hear the audio from the MCPTT user at client 1.

12. The MCPTT user at client 1 releases the floor.
13. The MCPTT server sends a floor idle message towards MCPTT client 1.
14. The MCPTT server sends a floor idle message towards MCPTT client 2.
15. The MCPTT server sends a floor idle message towards the IWF.
16. The IWF converts the RTCP floor idle message received from MCPTT into a GSM-R Mute message.
17. The IWF sends a Mute message using explicit signalling according to ETSI TS 103 389 [6] towards the GSM-R MSC.
18. The downlink of the GSM-R user at MS 1 is muted, therefore echo is avoided.

7.2.6 Handling of mute and unmute in GSM-R

7.2.6.1 General

In GSM-R a dispatcher connected via fixed line has to send an unmute message when he wants to talk (indicated by pressing the PTT button) to ensure that service subscribers that have the uplink can hear him. When the GSM-R dispatcher connected via fixed line does not want to talk any more (indicated by releasing the PTT button), a mute message will be sent. As analysed in ETSI TR 103 768 [i.1], these operations have no impact on the MCPTT side, hence also not on the IWF.

7.2.6.2 Procedure

Figure 7.2.6.2-1 illustrates the mute and unmute procedure on GSM-R.

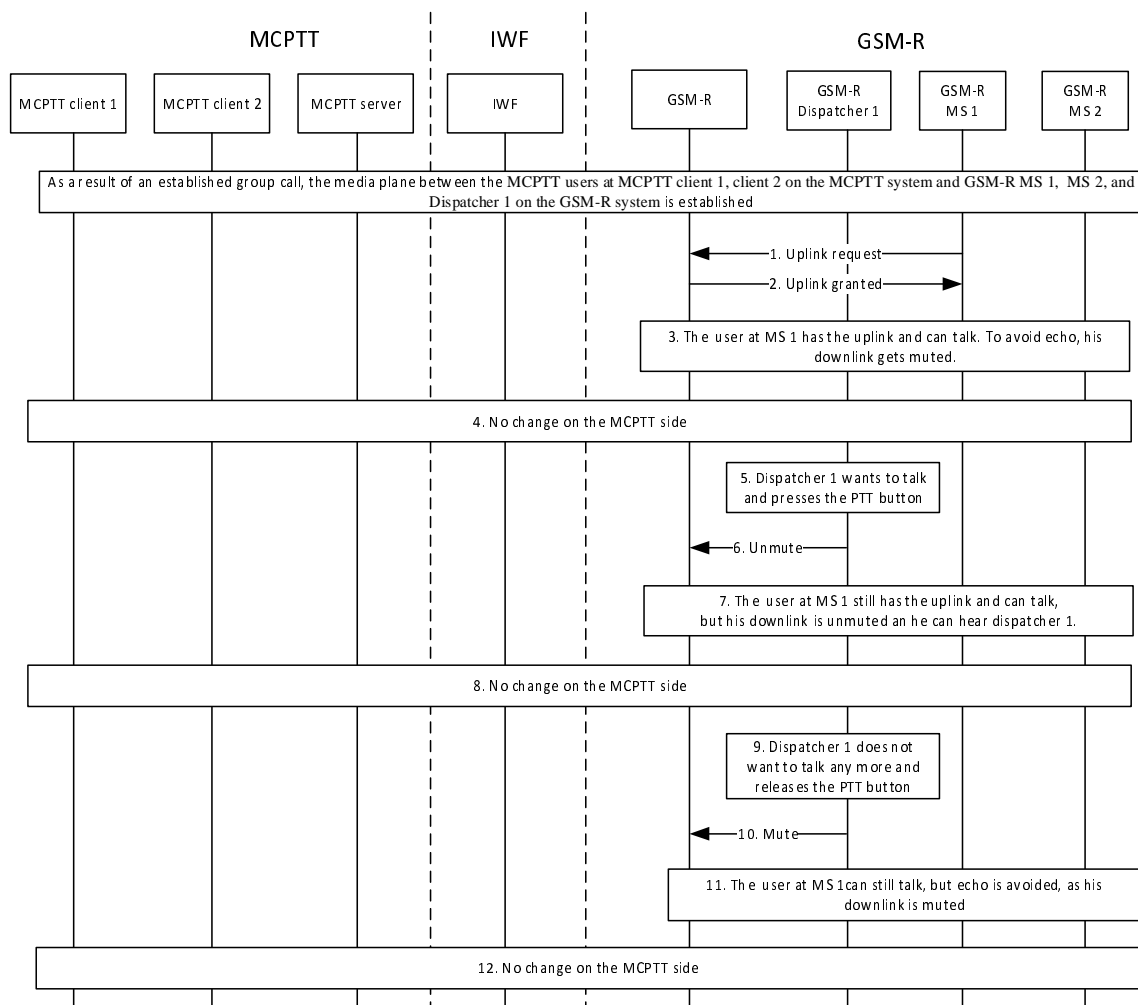

Figure 7.2.6.2-1: Mute/Unmute in GSM-R

The procedure shall be as follows:

1. GSM-R Mobile user at MS 1 wants to talk and requests the uplink.
2. GSM-R Mobile user at MS 1 gets the uplink.
3. GSM-R Mobile user at MS 1 has the uplink and can talk. To avoid echo, his downlink is muted.
4. No impact on the MCPTT side.
5. GSM-R dispatcher 1 wants to talk and presses the PTT button.
6. GSM-R dispatcher 1 sends an unmute message towards the GSM-R MSC.
7. GSM-R Mobile user at MS 1 continues to have the uplink and can talk, but his downlink is unmuted, and he can hear the audio from GSM-R dispatcher 1.
8. No impact on the MCPTT side.
9. GSM-R dispatcher 1 does not want to talk anymore and releases the PTT button.
10. GSM-R dispatcher 1 sends a mute message towards the GSM-R MSC.
11. GSM-R Mobile user at MS 1 still has the uplink and can talk, but to avoid echo, his downlink is muted.
12. No impact on the MCPTT side.

NOTE: Mute/unmute operations performed within GSM-R require no interaction with MCPTT.

7.2.7 Media encryption

As described in ETSI TR 103 768 [i.1], the media between GSM-R and MCPTT is exchanged between the systems via a call leg with duplex voice path. In the present document media is mixed on the GSM-R and on the MCPTT side. The mixing on the MCPTT side is planned to be done either centrally or locally (at the IWF). If the mixing is done centrally on the MCPTT side, as stated in ETSI TS 123 379 [i.6], end-to-end encryption of the media is not possible.

7.2.8 Codec negotiation

7.2.8.1 Codec negotiation for calls initiated by MCPTT user

Figure 7.2.8.1-1 is a simplified call setup procedure that illustrates the codec negotiation for calls initiated by a MCPTT user. The main characteristic of the procedure is to avoid transcoding by the MCPTT server by using AMR-WB as preferred codec. Additionally, the IWF removes the EVS-SWB codec with the result that only the AMR-WB codec is present in the outgoing offer from the IWF to GSM-R.

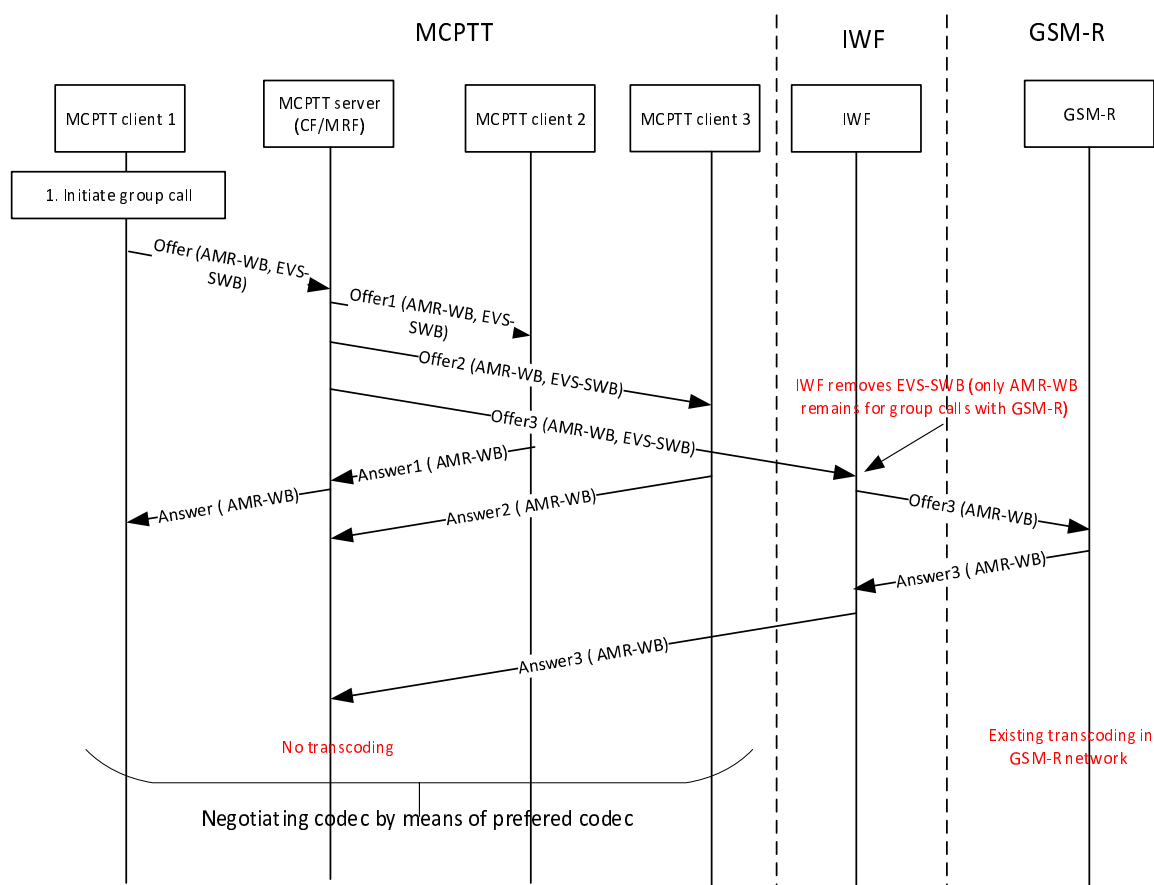

Figure 7.2.8.1-1: Codec negotiation for call initiated by an MCPTT user

7.2.8.2 Codec negotiation for calls initiated by GSM-R user

Figure 7.2.8.2-1 is a call setup procedure that illustrates the codec negotiation for calls initiated by a GSM-R user. The main characteristic of the procedure is that the IWF removes G.711 from all outgoing offers for group calls between MCPTT and GSM-R. Additionally within MCPTT transcoding is avoided by using AMR-WB as preferred codec.

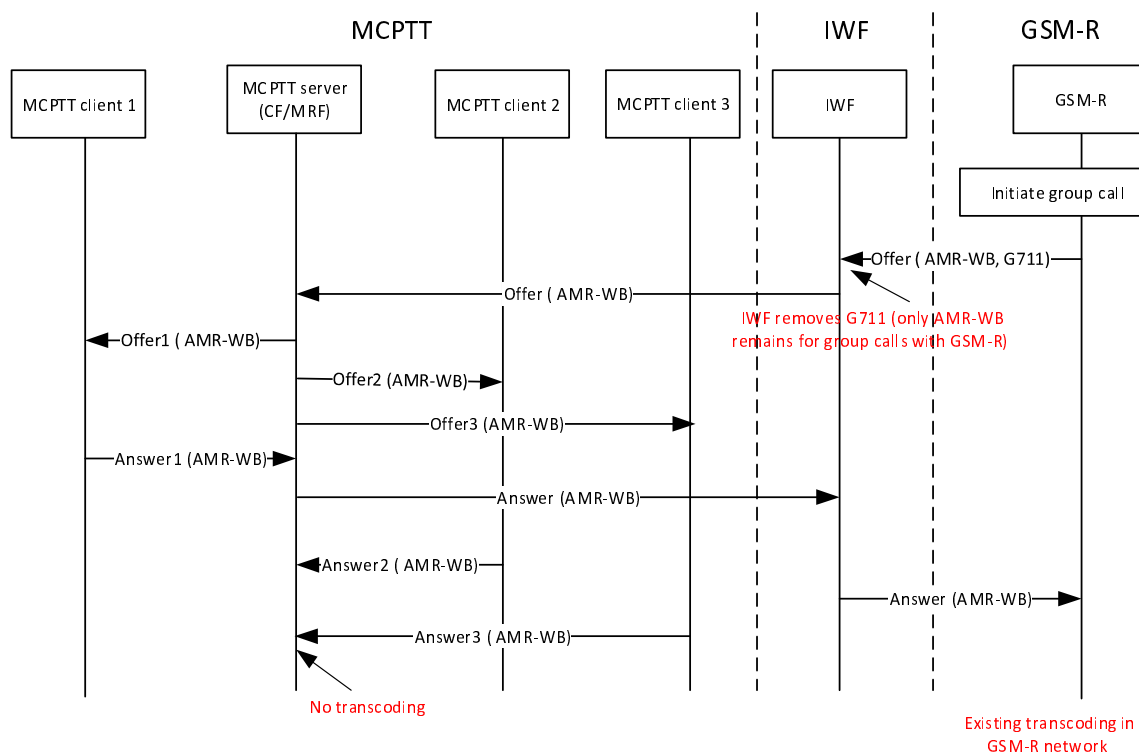

Figure 7.2.8.2-1: Codec negotiation for call initiated by a GSM-R user

7.2.9 Codec transcoding

FRMCS uses high-definition voice codec AMR-WB or EVS-SWB ("FRMCS codecs"). In the rest of the clause, the term "FRMCS codec" is used to designate the codec selected on the FRMCS side.

Clause 7.2.8 illustrates how the IWF is involved during codec negotiation to avoid transcoding by the MCPTT server. For a call involving FRMCS and GSM-R users, transcoding may be required between G.711 and AMR-WB depending on the codecs supported by the GSM-R system.

If AMR-WB is supported by the GSM-R system, as per clause 7.2.8, AMR-WB is used for a call involving FRMCS and GSM-R users.

If FRMCS codec is not supported by the GSM-R system, transcoding between G.711 and FRMCS codec needs to take place.

Annex A documents a set of possible approaches to ensure transcoding between G.711 and FRMCS codec which enables calls between FRMCS and GSM-R users.

8 Point-to-point call

8.1 General

This clause contains descriptions of stage 2 and stage 3 procedures for point-to-point calls interworking between GSM-R and FRMCS systems. For stage 3 procedures, it is described how information elements are mapped between GSM-R and MC messages. Other information elements in those GSM-R and MC messages which are not determined from such mapping are not described and should be determined by implementation, e.g. based on local service or configuration.

The messages and information elements shown in the mapping in this clause are specified in ETSI TS 103 389 [6] for GSM-R, in ETSI TS 123 283 [11] for MCPTT stage 2, and in ETSI TS 129 379 [8] and ETSI TS 124 379 [10] for MCPTT stage 3.

An MCPTT user is represented within the GSM-R system by an E.164 or EIRENE number. Therefore, calls placed by a GSM-R user to an MCPTT user are addressed to an E.164 or EIRENE number and calls received by a GSM-R user from an MCPTT user are identified by an E.164 or EIRENE number.

If a point-to-point call is originated by a GSM-R user, the GSM-R MSC shall act as the controlling system for the call. If the call is originated by an MCPTT user, the MCPTT system shall act as the controlling system for the call.

NOTE 1: Due to the assignment of controlling role to the system where the call originates (either GSM-R or FRMCS System), use of procedures of ETSI TS 129 379 [8] where the IWF acts in a participating role for call origination (clause 11.1.2.1) or in a controlling role for call termination (clause 11.1.3.2) are out of scope of the present document.

A point-to-point call is known as a 'private call' in 3GPP specifications.

A point-to-point call placed by a GSM-R user is set up without end-to-end encryption and the private call received by the GSM-R user from an MCPTT user also set up without end-to-end encryption.

NOTE 2: Media encryption for private calls is not available in the present document.

8.2 Point-to-point call from GSM-R user to user on MCPTT system

8.2.1 Point-to-point call

8.2.1.1 Stage 2 procedure

Point-to-point call known as 'private call with manual commencement mode' in 3GPP specifications shall be supported for GSM-R and FRMCS interworking.

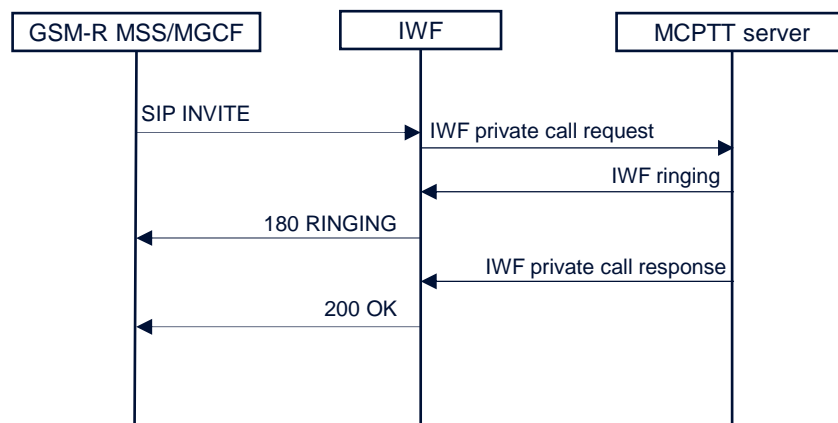

Figure 8.2.1.1-1: Point-to-point call from GSM-R user to user on MCPTT system (stage 2)

In Figure 8.2.1.1-1:

- The SIP interface between the MGCF and IWF is based on implementation of the reference point Mg/Mj as defined by ETSI TS 129 163 [12] and extended by parts of ETSI TS 103 389 [6].
- IWF private call request is defined in ETSI TS 123 283 [11], clause 10.4.1.2.
- IWF private call response is defined in ETSI TS 123 283 [11], clause 10.4.1.3.
- IWF ringing is defined in ETSI TS 123 283 [11], clause 10.4.1.4.

8.2.1.2 Stage 3 procedure

The 3GPP procedures for IWF originated calls are contained in ETSI TS 129 379 [8], clause 11.2.2.1 for calls without floor control (full duplex calls).

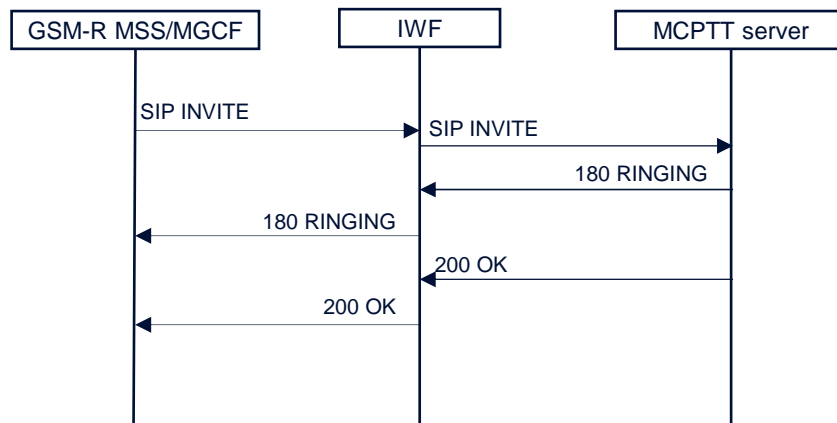

Figure 8.2.1.2-1: Point-to-point call from GSM-R user to user on MCPTT system (stage 3)

Figure 8.2.1.2-1 illustrates the procedure for a point-to-point call initiated by a GSM-R user to a user on an MCPTT system.

Construction of SIP INVITE at IWF

The IWF shall map the GSM-R identities to corresponding MCPTT identities:

- Calling party E.164/EIRENE number from the 'From' header field of the SIP INVITE is mapped (rules defined in clause 6.3.3) to an MCPTT ID/Functional Alias representing the calling GSM-R user.
- Called party E.164/EIRENE number from the 'Request-URI' header field is mapped (rules defined in clause 6.3.3) to the MCPTT ID/Functional Alias of the called user on the MCPTT system.

The SIP INVITE from IWF to MCPTT server shall be constructed according to ETSI TS 129 379 [8], clause 11, and shall include:

- A Resource-Priority header field is added, set to "normal priority" mcptt.x value, x=0 as (as defined in IETF RFC 8101 [5]). In addition the <user-requested-priority> field shall be added, set according to the Communication Session Category as specified in clause 6.2.5 in ETSI TS 103 765-2 [4] based on the received GSM-R Call Priority and depending on the configurable priority mapping between GSM-R and MCPTT.
- An Answer-Mode header field with the value "Manual" according to the rules and procedures of IETF RFC 5373[15].
- The MCPTT ID of the called MCPTT user copied into the <mcptt-request-uri> element in the application/vnd.3gpp.mcptt-info+xml MIME body of the outgoing SIP INVITE request.
- An mcptt-info MIME xml body that contains the MCPTT ID representing the calling GSM-R user in the <mcptt-calling-user-id> sub-element, and also containing:
 - an <mcptt-params> element in the MIME body with <session-type> element set to "private";
 - an encryption-mode attribute set to no encryption used.

No media-level section for a media-floor control entity is included according to the MCPTT client procedures specified in ETSI TS 124 379 [10], clause 11.1.2 for duplex calls.

NOTE: Media encryption for private calls is not available in the present document

Handling of SIP 180 RINGING at IWF

On receipt of a SIP 180 RINGING from the MCPTT server, the IWF shall send forward a SIP 180 RINGING message towards the GSM-R MSS/MGCF with elements according to ETSI TS 103 389 [6].

Handling of SIP 200 OK at IWF

On receipt of a SIP 200 OK from the MCPTT server, the IWF shall verify the media parameters in the SDP body match those requested. The IWF shall send a SIP 200 OK message towards the GSM-R MSS/MGCF with elements according to ETSI TS 103 389 [6].

The SIP 200 OK response from the MCPTT server includes a Contact header field, which contains the MCPTT session identity allocated to that session. This MCPTT session identity shall be retained by the IWF to be able to associate a later SIP BYE to that session.

8.2.2 Point-to-point call rejected by MCPTT system

8.2.2.1 Stage 2 procedure

Figure 8.2.2.1-1 shows the case where a call setup request initiated by a GSM-R user is rejected by the MCPTT system.

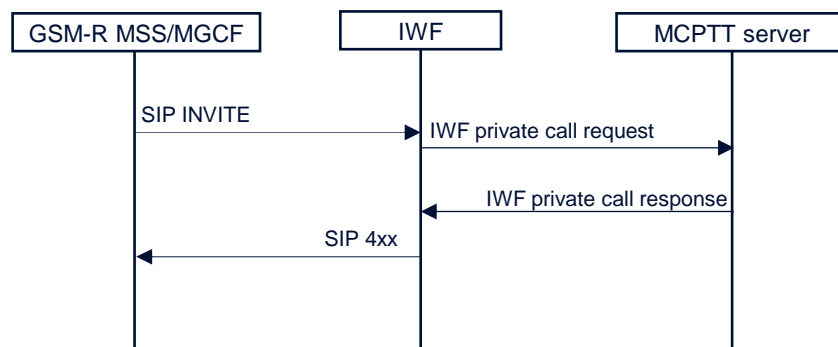

Figure 8.2.2.1-1: Point-to-point call rejected by MCPTT system (stage 2)

In Figure 8.2.2.1-1:

- The SIP interface between the MGCF and IWF is based on implementation of the reference point Mg/Mj as defined by ETSI TS 129 163 [12] and extended by parts of ETSI TS 103 389 [6].
- IWF private call request is defined in ETSI TS 123 283 [11], clause 10.4.1.2.
- IWF private call response is defined in ETSI TS 123 283 [11], clause 10.4.1.3.

8.2.2.2 Stage 3 procedure

Figure 8.2.2.2-1 shows the stage 3 procedure for an unsuccessful call setup from GSM-R user to an MCPTT user.

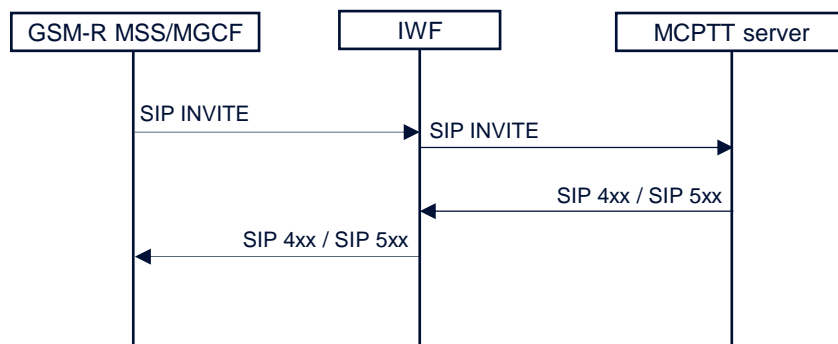

Figure 8.2.2.2-1: Point-to-point call rejected by MCPTT system (stage 3)

Construction of SIP INVITE

The SIP INVITE sent to the MCPTT server by the IWF is constructed as described in clause 8.2.1.2 of the present document.

Handling SIP 4xx and SIP 5xx

On receipt of a SIP 4xx or SIP 5xx rejection response from the MCPTT server, the IWF shall forward the SIP rejection response to the GSM-R MSS/MGCF.

8.3 Point-to-point call initiated by an MCPTT user

8.3.1 Point-to-point call

8.3.1.1 Stage 2 procedure

Figure 8.3.1.1-1 shows the procedure for a successful point-to-point call initiated by a user on the MCPTT system to a GSM-R user.

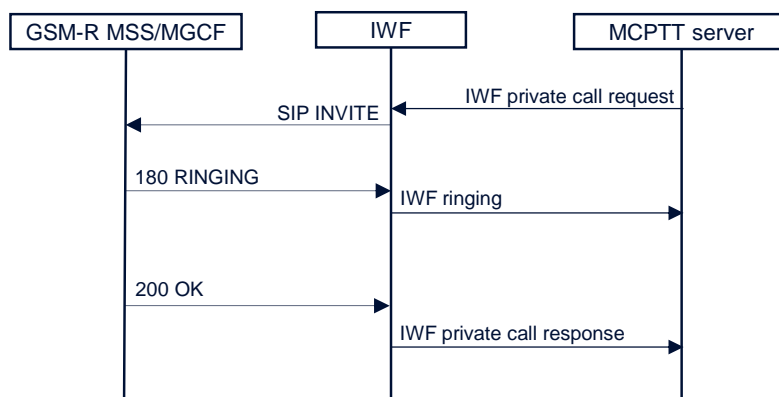

Figure 8.3.1.1-1: Point-to-point call initiated by an MCPTT user (stage 2)

In Figure 8.3.1.1-1:

- The SIP interface between the MGCF and IWF is based on implementation of the reference point Mg/Mj as defined by ETSI TS 129 163 [12] and extended by parts of ETSI TS 103 389 [6].
- IWF private call request is defined in ETSI TS 123 283 [11], clause 10.4.1.2.
- IWF private call response is defined in ETSI TS 123 283 [11], clause 10.4.1.3.
- IWF ringing is defined in ETSI TS 123 283 [11], clause 10.4.1.4.

8.3.1.2 Stage 3 procedure

The 3GPP procedures for IWF terminated calls are contained in ETSI TS 129 379 [8], clause 11.2.2.1 for calls without floor control (full duplex calls).

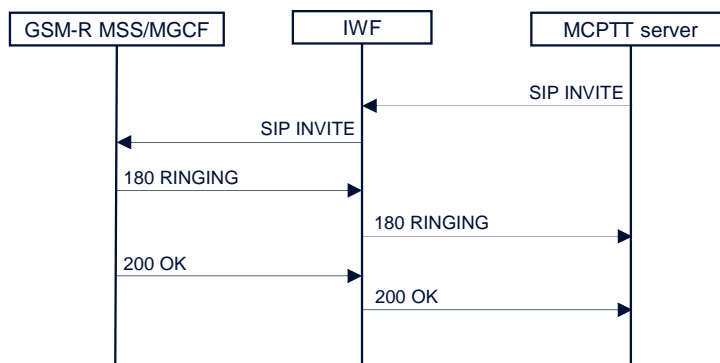

Figure 8.3.1.2-1: Point-to-point call initiated by an MCPTT user (stage 3)

Figure 8.3.1.2-1 illustrates the procedure for a point-to-point call initiated by an MCPTT user to a user on an GSM-R system.

Construction of SIP INVITE

The IWF shall map the MCPTT identities to corresponding GSM-R identities:

- Calling party MCPPT ID/Functional Alias of the SIP INVITE is mapped (rules defined in clause 6.3.3) to an E.164 or EIRENE SIP-R URI representing the calling user on the MCPTT system.
- Called party MCPTT ID/Functional Alias is mapped (rules defined in clause 6.3.3) to the E.164 or EIRENE SIP-R URI of the called user on the GSM-R system.

The SIP INVITE from IWF to GSM-R MSS/MGCF shall be constructed based on ETSI TS 103 389 [6], and shall include:

- GSM-R Call Priority depending on the configurable priority mapping between GSM-R and MCPTT.

Handling SIP 180 RINGING

On receipt of a SIP 180 RINGING from the GSM-R MSS/MGCF, the IWF shall send forward a SIP 180 RINGING message towards the MCPTT server with elements according to ETSI TS 129 379 [8].

Handling SIP 200 OK

On receipt of a SIP 200 OK from the GSM-R MSS/MGCF, the IWF shall verify the media parameters in the SDP body match those requested. The IWF shall send a SIP 200 OK message towards the MCPTT server with elements according to ETSI TS 129 379 [8].

8.3.2 Point-to-point call rejected by GSM-R system

8.3.2.1 Stage 2 procedure

Figure 8.3.2.1-1 shows the case where a call setup request initiated by a MCPTT user is rejected by the GSM-R system.

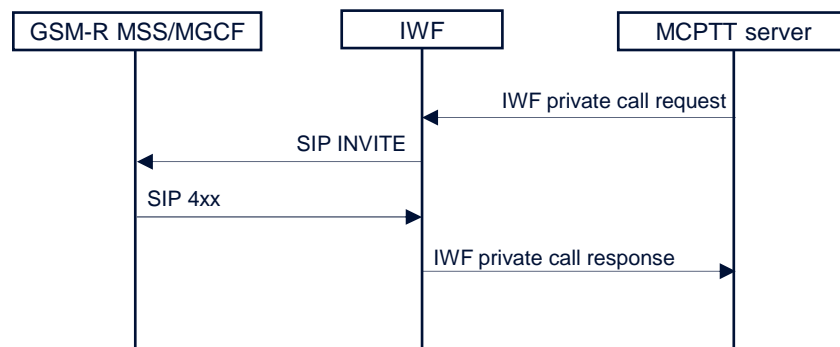

Figure 8.3.2.1-1: Point-to-point call rejected by GSM-R system (stage 2)

In Figure 8.3.2.1-1:

- The SIP interface between the MGCF and IWF is based on implementation of the reference point Mg/Mj as defined by ETSI TS 129 163 [12] and extended by parts of ETSI TS 103 389 [6].
- IWF private call request is defined in ETSI TS 123 283 [11], clause 10.4.1.2.
- IWF private call response is defined in ETSI TS 123 283 [11], clause 10.4.1.3.

8.3.2.2 Stage 3 procedure

Figure 8.3.2.2-1 shows the stage 3 procedure for an unsuccessful call setup from MCPTT user to a GSM-R user.

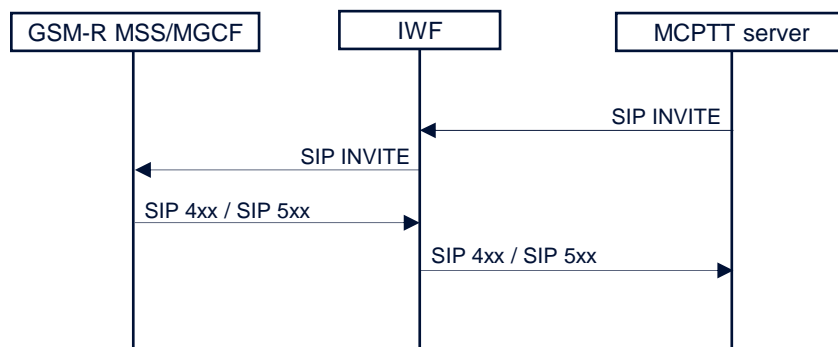

Figure 8.3.2.2-1: Point-to-point call rejected by GSM-R system (stage 3)

Construction of SIP INVITE

The SIP INVITE sent to the GSM-R MSS/MGCF by the IWF is constructed as described in clause 8.3.1.2 of the present document.

Handling SIP 4xx and SIP 5xx

On receipt of a SIP 4xx or SIP 5xx rejection response from the GSM-R MSS/MGCF, the IWF shall forward the SIP 4xx or SIP 5xx rejection response to the MCPTT server.

8.4 Point-to-point call release

8.4.1 Individual call release by GSM-R user

8.4.1.1 Stage 2 procedure

Figure 8.4.1.1-1 shows the stage 2 procedure for disconnection of a point-to-point call, where the disconnection is initiated by a GSM-R user.

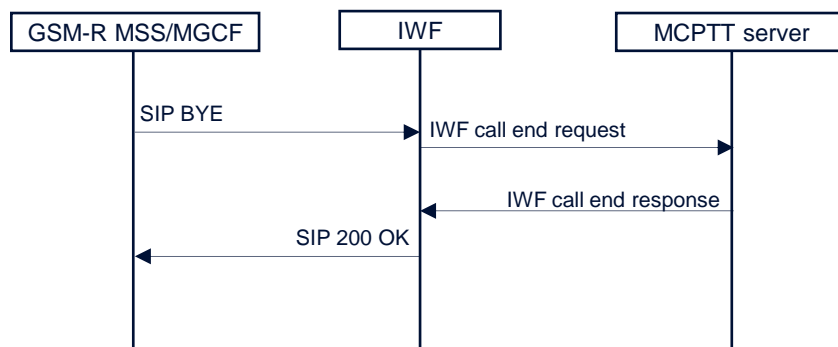

Figure 8.4.1.1-1: Point-to-point call release (stage 2)

In Figure 8.4.1.1-1:

- The SIP interface between the MGCF and IWF is based on implementation of the reference point Mg/Mj as defined by ETSI TS 129 163 [12] and extended by parts of ETSI TS 103 389 [6].
- IWF call end request is defined in ETSI TS 123 283 [11], clause 10.4.1.5.
- IWF call end response is defined in ETSI TS 123 283 [11], clause 10.4.1.6.

8.4.1.2 Stage 3 procedure

Figure 8.4.1.2-1 shows the stage 3 procedure for disconnection of a point-to-point call, where the disconnection is initiated by a GSM-R user.

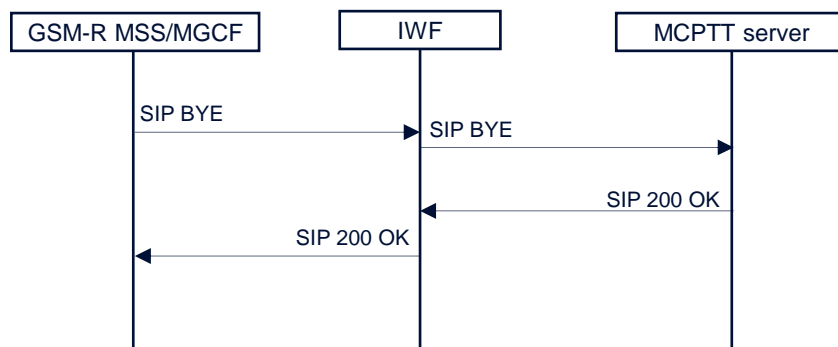

Figure 8.4.1.2-1: Point-to-point call release (stage 3)

On receipt of a SIP BYE message from the GSM-R MSS/MGCF, the IWF shall forward the SIP BYE message to the MCPTT server.

The IWF shall forward the 200 OK to the GSM-R MSS/MGCF when received from the MCPTT server.

8.4.2 Individual call release by FRMCS user

8.4.2.1 Stage 2 procedure

Figure 8.4.2.1-1 shows the stage 2 procedure for disconnection of a point-to-point call, where the disconnection is initiated by an FRMCS user.

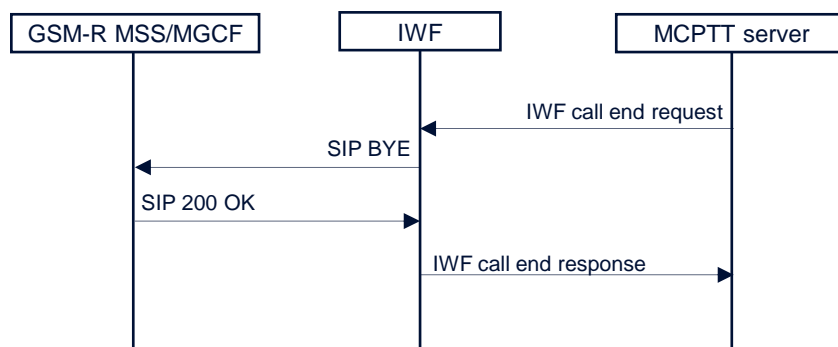

Figure 8.4.2.1-1: Individual call release by FRMCS user (stage 2)

In Figure 8.4.2.1-1:

- The SIP interface between the MGCF and IWF is based on implementation of the reference point Mg/Mj as defined by ETSI TS 129 163 [12] and extended by parts of ETSI TS 103 389 [6].
- IWF call end request is defined in ETSI TS 123 283 [11], clause 10.4.1.5.
- IWF call end response is defined in ETSI TS 123 283 [11], clause 10.4.1.6.

8.4.2.2 Stage 3 procedure

Figure 8.4.2.2-1 shows the stage 3 procedure for disconnection of a point-to-point call, where the disconnection is initiated by an FRMCS user.

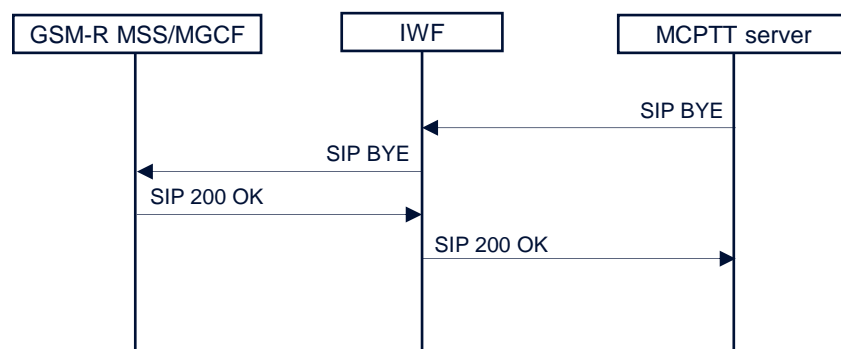

Figure 8.4.2.2-1: Individual call release by FRMCS user (stage 3)

On receipt of a SIP BYE message from the MCPTT server, the IWF shall forward the SIP BYE message to the GSM-R MSS/MGCF.

The IWF shall forward the 200 OK to the MCPTT server when received from the GSM-R MSS/MGCF.

9 Text messaging service

9.1 General

This clause contains Stage 2 and Stage 3 protocol procedures for the interworking of short data enabled services between GSM-R and 3GPP MC systems supported in the present document.

9.2 One-to-one text messaging procedures

9.2.1 One-to-one SDS to Instant Messaging interworking principles

The IWF receives text messages as Instant Messages from the GSM-R IP-SM-GW. It is assumed that the IP-SM-GW use Service Level Interworking (SLI) according to ETSI TS 129 311 [i.10], in order to create Instant Messages from SMS and to create SMS from Instant Messages. The IWF shall interwork Instant Messages (at the IWF-g5 reference point) with MCDData SDS messages (at the IWF-2 reference point). The IWF behaves as MCDData participating function to the MCDData controlling function on the FRMCS side and it implements the ISC interface as an S-CSCF to the IP-SM-GW on the GSM-R side. The GSM-R users behind the IWF are represented by MCDData IDs, MCDData group IDs or by Functional Aliases, as appropriate.

ETSI TS 129 311 [i.10] specifies the Instant Messaging to be based on OMA-TS-SIMPLE_IM protocol.

MCDData SDS IWF messaging shall be supported using the signalling plane.

ETSI TS 123 283 [11] describes the functional model for the IWF-2 interface used for the SDS message interworking. IWF-2 supports a subset of the functionality of MCDData-SDS 1, as defined in ETSI TS 123 282 [i.7] with some differences, as specified in the present document. The IWF-2 interface is supported by the same signalling plane protocol(s) as defined for MCDData 3 except as specified in the present document.

MCDData-SDS-1 reference point is used for MCDData application signalling during session establishment in support of SDS data transfer. MCDData-SDS-1 reference point is also used for unicast SDS data transaction over signalling control plane by the SDS distribution function of the MCDData server and SDS function of the IWF Gateway.

GSM-R users behind the IWF are mapped to MCDData IDs as described above in the Point-to-Point call mapping and so the MCDData server shall be capable of routing messages towards identities located behind the IWF.

The procedure for an MCDData user requesting to send a signalling control plane SDS to a GSM-R user is as specified in ETSI TS 123 282 [i.7], clause 7.4.2.2 for the one-to-one standalone short data service using the signalling control plane, with the exception that MCDData client 2 is located behind the IWF. The SDS is addressed to the MCDData ID that has been allocated to the GSM-R user. The IWF behaves as a peer MCDData server.

SDS messages can support a maximum of 1000 bytes. IP-SM-GW outside of the IWF will be responsible for concatenation to individual SMS messages or cropping the message to fit on SMS message. This is out of the scope of the IWF Gateway.

In the direction of IWF to IP-SM-GW, the S-CSCF function of the IWF shall send Instant Messages using the SIP MESSAGE request.

Applying the related procedures for an Application Server acting as an originating User Agent as defined in clause 5.7.3 in ETSI TS 124 229 [i.11] as well as IETF RFC 3428 [14]. The SIP MESSAGE shall contain a body, using the standard MIME header fields to identify the content.

In addition, the S-CSCF function of the IWF shall include in the SIP MESSAGE request:

- a) the Request URI set to a Tel URI corresponding to the MSISDN of the recipient. The IMSI is derived from the mapping procedures used in a point-to-point call above. The called MCDData User Identity or the Functional Alias Identity is mapped to obtain the destination MSISDN; In the SIP MESSAGE this element shall be placed in the to: field;
- b) the SIM MESSAGE from: field is derived from the mapping procedures used in a point-to-point call above. The calling MCDData User Identity or the Functional Alias Identity is mapped to obtain the originating MSISDN in a Tel URI format;
- c) the appropriate MIME type(s) in the Content-Type header field; The Content-Type is always text/plain;
- d) an Accept-Contact header field with the IM feature-tag "+g.oma.sip-im";
- e) a User-Agent header field to indicate the IM release version as specified in OMA-TS-SIMPLE_IM;
- f) a Request-Disposition header field with the value "no-queue", as specified in IETF RFC 3841 [17], in order to ensure the SIP MESSAGE request is not queued for delivery if the recipient is temporarily unreachable; and
- g) the contents of the Body set to the contents of the Short Message(s) formatted in appropriate MIME type based on received content in MCDData SDS.

Since an MCDData SDS can contain up to 1 000 bytes there is an option of sending a large Instant Message. It is the responsibility of the IP-SM-GW to concatenate or crop the large Instant Message based on configuration. This is out of the scope of the present document.

The IP-SM-GW will respond with a SIP Message 200 OK upon successful disposition of the message with the same Call-ID and Cseq as the original message for disposition correlation.

A SIP 4xx or SIP 5xx response indicates that the message was not delivered successfully. A SIP 6xx response means it was delivered successfully but refused.

In the direction of IP-SM-GW to IWF, the S-CSCF function shall:

- 1) send a SIP MESSAGE request as defined in IETF RFC 3428 [14]. The SIP MESSAGE shall contain a body, using the standard MIME header fields to identify the content;
- 2) the FA(164) corresponding to the MSISDN or Functional Number of the recipient. This element shall be placed in the to: field;
- 3) The SIP MESSAGE from: field is the originating MSISDN or originating EIRENE Functional Number in a Tel URI format;
- 4) the appropriate MIME type(s) in the Content-Type header field; The Content-Type is always text/plain;
- 5) a Request-Disposition header field with the value "no-queue", as specified in IETF RFC 3841 [17], in order to ensure the SIP MESSAGE request is not queued for delivery if the recipient is temporarily unreachable; and
- 6) the contents of the Body set to the contents of the Short Message(s) formatted in appropriate MIME type based on based on received content in GSM-R SMS.

The S-CSCF of the IWF will respond with a SIP Message 200 OK upon successful disposition of the message with the same Call-ID and Cseq as the original message for disposition correlation.

A SIP 4xx or SIP 5xx response indicates that the message was not delivered successfully. A SIP 6xx response means it was delivered successfully but refused.

Table 9.2.1-1 describes the information elements sent from the MCDData server to the IWF for the MCDData standalone data request (defined in ETSI TS 123 282 [i.7], clauses 7.4.2.2.2 and 7.4.2.3.2).

Table 9.2.1-1: IWF MCDData standalone data request

MCDATA SDS Information element	Instant Message Parameter	Status	Description
MCDATA ID	SIP Tel URI in from: field	M	The identity of the MCDATA user sending
Functional alias	SIP URI (EIRENE) in from: field	O	The associated functional alias of the MCDATA user sending data
MCDATA ID	SIP URI (MSISDN) In SIP MESSAGE to: field P-Asserted Identity	M	The identity of the MCDATA user towards which the data is sent
Functional alias	SIP URI (EIRENE) in to: field	O	The associated functional alias of the destination MCDATA user mapped from EIRENE Functional Number in IWF
Conversation Identifier (see note)	Call-ID	M	Identifies the conversation
Transaction Identifier (see note)			Identifies the MCDATA transaction Ignored by IWF
Reply Identifier		O	Identifies the original MCDATA transaction to which the current transaction is a reply to
Disposition Type		O	GSM-R SMS supports delivery disposition only
Payload	MIME message body	M	SDS Content
Application identifier (see note)		O	Not applicable to FRMCS
		M	SDS content
NOTE:	A reserved value of the Information Element needs to be defined which indicates that the sender does not support this Information Element.		

Table 9.2.1-2 describes the information elements sent from the IWF to the MCDData server for the MCDData data disposition notification (defined in ETSI TS 123 282 [i.7], clauses 7.4.2.2.2 and 7.4.2.3.2).

Table 9.2.1-2: IWF MCDData data disposition notification

Information element	Status	Description
MCDATA ID	M	The identity of the MCDATA user towards which the notification is sent
MCDATA ID	M	The identity of the MCDATA user sending notification
Conversation Identifier (see note)	M	Identifies the conversation associated with SIP MESSAGE Call-ID
Disposition association	M	Identity of the original MCDATA transaction
Disposition	M	Disposition which is delivered or read or both (only delivery is supported in GSM-R)
NOTE:	A reserved value of the Information Element needs to be defined which indicates that the sender does not support this Information Element.	

For both the point-to-point text messaging GSM-R SMS to MCDATA service user and the vice versa MCDATA short message to GSM-R Subscriber, the addressing framework as described in clause 6 shall be used.

The interworking framework utilizes the IWF-g5 reference on the GSM-R side and the IWF-2 reference point on the FRMCS side as depicted in Figure 5.1-1.

9.3 One-to-One text messaging protocols IWF to/from the MCDData server

In the direction of MCDData server to IWF Gateway

The MCDData server shall send a SIP MESSAGE request for standalone SDS for terminating GSM-R subscriber.

This SIP MESSAGE request is routed to the IWF GW with an Accept-Contact header field with the g.3gpp.icsi-ref media feature tag containing the value of "urn:urn-7:3gpp-service.ims.icsi.mcddata.sds", and an ICSI value "urn:urn-7:3gpp-service.ims.icsi.mcddata.sds" in a P-Asserted-Service header field.

This URN indicates that the device has the capabilities to support the Mission Critical Data (MCDData) Short Data Service (SDS) IMS communication service. This URN is also used by the device to associate a SIP request with the Mission Critical Data (MCDData) Short Data Service (SDS) IMS communication service.

This SIP MESSAGE is routed to the MCDData client with an Accept-Contact header field with the g.3gpp.icsi-ref media feature tag containing the value of "urn:urn-7:3gpp-service.ims.icsi.mcddata.sds", and an ICSI value "urn:urn-7:3gpp-service.ims.icsi.mcddata.sds" in a P-Asserted-Service header field, and with an application/vnd.3gpp.mcddata-signalling MIME body containing an SDS NOTIFICATION message.

If the IWF Gateway is unable to process the request due to a lack of resources or a risk of congestion exists, the IWF Gateway may reject the SIP MESSAGE request with a SIP 500 (Server Internal Error) response. The IWF Gateway may include a Retry-After header field to the SIP 500 (Server Internal Error) response as specified in IETF RFC 3261[16] and skip the rest of the steps.

The IWF Gateway shall determine the MCDData ID of the calling user from the user identity in the P-Asserted-Identity header field of the SIP MESSAGE.

The IWF Gateway shall perform the mapping of the MCDData ID of the calling user to a GSM-R identity in the same manner as described in the Point-to-Point call procedures above.

If the IWF Gateway cannot find a mapping between a GSM-R identity and an MCDData ID, then IWF Gateway shall reject the SIP MESSAGE request with a SIP 404 (Not Found) response with the warning text set to "141 user unknown to the participating function" in a Warning header field as specified in clause 4.9 of ETSI TS 124 282 [9] and shall not continue with any of the remaining steps.

When the SDS message is successfully sent to the GSM-R side and a delivery disposition is received, the IWF shall send to the MCDData server a SDS Notification message with the following information elements as described in ETSI TS 124 282 [9].

In order to generate an SDS notification, the IWF Gateway:

- 1) shall generate an SDS NOTIFICATION message as specified in clause 15.1.5 of ETSI TS 124 282 [9]; and
- 2) shall include in the SIP request, the SDS NOTIFICATION message in an application/vnd.3gpp.mcddata-signalling MIME body as specified in clause E.1 of ETSI TS 124 282 [9].

When generating an SDS NOTIFICATION message as specified in clause 15.1.5 of ETSI TS 124 282 [9], the MCDData client:

- 1) if sending a delivered notification, shall set the SDS disposition notification type IE as "DELIVERED" as specified in clause 15.2.5 of ETSI TS 124 282 [9];
- 2) if the SDS message could not be delivered to the user or application (e.g. due to lack of storage), shall set the SDS disposition notification type IE as "UNDELIVERED" as specified in clause 15.2.5 of ETSI TS 124 282 [9];
- 3) shall set the Date and time IE to the current time to as specified in clause 15.2.8 of ETSI TS 124 282 [9];
- 4) shall set the Conversation ID to the value of the Conversation ID that was received in the SDS message as specified in clause 15.2.9 of ETSI TS 124 282 [9];
- 5) shall set the Message ID to the value of the Message ID that was received in the SDS message as specified in clause 15.2.10 of ETSI TS 124 282 [9];

- 6) shall not include an Application ID IE (as specified in clause 15.2.7 of ETSI TS 124 282 [9]) and shall not include an Extended application ID IE (as specified in clause 15.2.24 of ETSI TS 124 282 [9]).

In the direction of IWF to MCDATA server, the IWF Gateway shall

- 1) shall determine the public service identity of the called MCDATA user associated with the mapped identity in the received SIP MESSAGE request from the SM-IW-GW. The mapping procedure is identical to that of point-to-point call as described above;
- 2) shall generate an SDS SIGNALLING PAYLOAD message in the application/vnd.3gpp.mcdata-signalling MIME body as specified in clause 15.1.2 of ETSI TS 124 282 [9];
- 3) shall generate a DATA PAYLOAD message as specified in clause 15.1.4 of ETSI TS 124 282 [9];
- 4) shall include in the SIP request, the SDS SIGNALLING PAYLOAD message in an application/vnd.3gpp.mcdata-signalling MIME body as specified in clause E.1 of ETSI TS 124 282 [9]; and
- 5) shall include in the SIP request, the DATA PAYLOAD message in an application/vnd.3gpp.mcdata-payload MIME body as specified in clause E.2 of ETSI TS 124 282 [9].

When generating an SDS SIGNALLING PAYLOAD message as specified in clause 15.1.2 of ETSI TS 124 282 [9], the MCDATA client:

- 1) shall set the Date and time IE to the current time as specified in clause 15.2.8 of ETSI TS 124 282 [9];
- 2) shall set the Conversation ID IE to a newly generated Conversation ID value as specified in clause 15.2.9 of ETSI TS 124 282 [9];
- 3) shall set the Message ID IE to a newly generated Message ID value as specified in clause 15.2.10 of ETSI TS 124 282 [9];
- 4) shall not include an Application ID IE as specified in clause 15.2.7 of ETSI TS 124 282 [9] and shall not include an Extended application ID IE as specified in clause 15.2.24 of ETSI TS 124 282 [9];
- 5) shall include a SDS disposition request type IE set to "DELIVERY" as specified in clause 15.2.3 of ETSI TS 124 282 [9];

When generating an DATA PAYLOAD message for SDS as specified in clause 15.1.4 of ETSI TS 124 282 [9], the IWF Gateway:

- 1) shall set the Number of payloads IE to 1, as specified in clause 15.2.12 of ETSI TS 124 282 [9];
- 2) shall include the Security parameters and Payload IE with security parameters as described in ETSI TS 133 180 [13];
- 3) shall set the Payload content type as "TEXT" as specified in clause 15.2.13 of ETSI TS 124 282 [9];
- 4) shall include the data to be sent in the Payload data.

When the SDS message is successfully sent to the MCDATA server and a delivery disposition is expected, the MCDATA server will send to the IWF a SDS Notification message with the information elements as described in ETSI TS 124 282 [9], clause 6.2.2.1 [9].

Annex A (informative): Voice transcoding to and from AMR-WB when AMR-WB is not supported by a GSM-R system

A.1 Introduction

This annex identifies a set of technical approaches to ensure transcoding between G.711 and FRMCS codec to enable a call involving FRMCS users served by a FRMCS Domain and GSM-R users served by a GSM-R system when GSM-R system does not support the FRMCS codec or transcoding between AMR-WB and G.711.

A.2 Transcoding in a GSM-R system

In this clause, the FRMCS Operator is assumed to also operate a GSM-R system which is able to do the transcoding. The transcoding from the FRMCS codec to the GSM-R codec would take place as described in clause 7.2.8 with the GSM-R system being the GSM-R system associated to the FRMCS operator. Subsequently, the call path would be completed through the interconnection between the two GSM-R systems.

A.3 Implementation of transcoding in the FRMCS Domain

The FRMCS Operator may implement a transcoding function within FRMCS Domain. The transcoding function performs transcoding between the FRMCS codec and the G.711 codec used at the interface to the GSM-R System.

The transcoding function could take different forms such as a MGCF/MGW combination, the usage of the MCX MDF or the IWF itself.

History

Version	Date	Status
V1.0.0	July 2025	SRdAP process EV 20251008: 2025-07-10 to 2025-10-08
V1.1.1	January 2026	Publication