

ETSI TS 123 256 V18.2.0 (2024-05)



TECHNICAL SPECIFICATION

**5G;
Support of Uncrewed Aerial Systems (UAS) connectivity,
identification and tracking;
Stage 2
(3GPP TS 23.256 version 18.2.0 Release 18)**



A GLOBAL INITIATIVE

Reference

RTS/TSGS-0223256vi20

Keywords

5G

ETSI

650 Route des Lucioles
F-06921 Sophia Antipolis Cedex - FRANCE

Tel.: +33 4 92 94 42 00 Fax: +33 4 93 65 47 16

Siret N° 348 623 562 00017 - APE 7112B
Association à but non lucratif enregistrée à la
Sous-Préfecture de Grasse (06) N° w061004871

Important notice

The present document can be downloaded from:

<https://www.etsi.org/standards-search>

The present document may be made available in electronic versions and/or in print. The content of any electronic and/or print versions of the present document shall not be modified without the prior written authorization of ETSI. In case of any existing or perceived difference in contents between such versions and/or in print, the prevailing version of an ETSI deliverable is the one made publicly available in PDF format at www.etsi.org/deliver.

Users of the present document should be aware that the document may be subject to revision or change of status.

Information on the current status of this and other ETSI documents is available at

<https://portal.etsi.org/TB/ETSIDeliverableStatus.aspx>

If you find errors in the present document, please send your comment to one of the following services:

<https://portal.etsi.org/People/CommitteeSupportStaff.aspx>

If you find a security vulnerability in the present document, please report it through our
Coordinated Vulnerability Disclosure Program:

<https://www.etsi.org/standards/coordinated-vulnerability-disclosure>

Notice of disclaimer & limitation of liability

The information provided in the present deliverable is directed solely to professionals who have the appropriate degree of experience to understand and interpret its content in accordance with generally accepted engineering or other professional standard and applicable regulations.

No recommendation as to products and services or vendors is made or should be implied.

No representation or warranty is made that this deliverable is technically accurate or sufficient or conforms to any law and/or governmental rule and/or regulation and further, no representation or warranty is made of merchantability or fitness for any particular purpose or against infringement of intellectual property rights.

In no event shall ETSI be held liable for loss of profits or any other incidental or consequential damages.

Any software contained in this deliverable is provided "AS IS" with no warranties, express or implied, including but not limited to, the warranties of merchantability, fitness for a particular purpose and non-infringement of intellectual property rights and ETSI shall not be held liable in any event for any damages whatsoever (including, without limitation, damages for loss of profits, business interruption, loss of information, or any other pecuniary loss) arising out of or related to the use of or inability to use the software.

Copyright Notification

No part may be reproduced or utilized in any form or by any means, electronic or mechanical, including photocopying and microfilm except as authorized by written permission of ETSI.

The content of the PDF version shall not be modified without the written authorization of ETSI.

The copyright and the foregoing restriction extend to reproduction in all media.

© ETSI 2024.
All rights reserved.

Intellectual Property Rights

Essential patents

IPRs essential or potentially essential to normative deliverables may have been declared to ETSI. The declarations pertaining to these essential IPRs, if any, are publicly available for **ETSI members and non-members**, and can be found in ETSI SR 000 314: "*Intellectual Property Rights (IPRs); Essential, or potentially Essential, IPRs notified to ETSI in respect of ETSI standards*", which is available from the ETSI Secretariat. Latest updates are available on the ETSI Web server (<https://ipr.etsi.org/>).

Pursuant to the ETSI Directives including the ETSI IPR Policy, no investigation regarding the essentiality of IPRs, including IPR searches, has been carried out by ETSI. No guarantee can be given as to the existence of other IPRs not referenced in ETSI SR 000 314 (or the updates on the ETSI Web server) which are, or may be, or may become, essential to the present document.

Trademarks

The present document may include trademarks and/or tradenames which are asserted and/or registered by their owners. ETSI claims no ownership of these except for any which are indicated as being the property of ETSI, and conveys no right to use or reproduce any trademark and/or tradename. Mention of those trademarks in the present document does not constitute an endorsement by ETSI of products, services or organizations associated with those trademarks.

DECT™, **PLUGTESTS™**, **UMTS™** and the ETSI logo are trademarks of ETSI registered for the benefit of its Members. **3GPP™** and **LTE™** are trademarks of ETSI registered for the benefit of its Members and of the 3GPP Organizational Partners. **oneM2M™** logo is a trademark of ETSI registered for the benefit of its Members and of the oneM2M Partners. **GSM®** and the GSM logo are trademarks registered and owned by the GSM Association.

Legal Notice

This Technical Specification (TS) has been produced by ETSI 3rd Generation Partnership Project (3GPP).

The present document may refer to technical specifications or reports using their 3GPP identities. These shall be interpreted as being references to the corresponding ETSI deliverables.

The cross reference between 3GPP and ETSI identities can be found under <https://webapp.etsi.org/key/queryform.asp>.

Modal verbs terminology

In the present document "**shall**", "**shall not**", "**should**", "**should not**", "**may**", "**need not**", "**will**", "**will not**", "**can**" and "**cannot**" are to be interpreted as described in clause 3.2 of the [ETSI Drafting Rules](#) (Verbal forms for the expression of provisions).

"**must**" and "**must not**" are **NOT** allowed in ETSI deliverables except when used in direct citation.

Contents

Intellectual Property Rights	2
Legal Notice	2
Modal verbs terminology.....	2
Foreword.....	7
1 Scope	9
2 References	9
3 Definitions and abbreviations.....	10
3.1 Definitions	10
3.2 Abbreviations	12
4 Architecture model and concepts	13
4.1 General concept.....	13
4.2 Architectural reference model	13
4.2.1 General.....	13
4.2.1.1 Support for general UAV features	13
4.2.1.2 Void.....	15
4.2.2 Logical UAV Reference Architecture.....	15
4.2.3 5GS Non-roaming Reference Architecture.....	17
4.2.4 5GS Roaming Reference Architecture.....	18
4.2.4A Void	19
4.2.5 Service-based interfaces	19
4.2.6 Reference points	20
4.3 Functional entities	20
4.3.1 General.....	20
4.3.2 UAS NF	20
4.3.3 UAV.....	20
4.3.4 AMF.....	21
4.3.5 SMF	21
4.3.6 SMF+PGW-C	22
4.3.7 PCF	22
4.3.8 UDM.....	22
4.3.9 A2X Application Server	22
4.3.10 UDR.....	22
4.3.11 NRF	22
4.4 High level function	23
4.4.1 Service Operations	23
4.4.1.1 NEF Services.....	23
4.4.1.1.1 General	23
4.4.1.1.2 Nnef_Authentication service	23
4.4.1.2 AF Services	24
4.4.1.2.1 General	24
4.4.1.2.2 Naf_Authentication service	24
4.4.1.3 AMF Services	25
4.4.1.4 SMF Services	25
4.4.1.5 UDM Services.....	25
4.4.1.6 LMF Services.....	25
4.4.1.7 GMLC Services.....	25
4.4.1.8 UDR Services.....	25
4.4.1.9 PCF Services	25
4.4.2 USS Discovery.....	25
4.4.3 CAA-Level UAV ID Assignment.....	26
4.5 Identifiers	27
4.5.1 General.....	27
4.5.2 CAA-Level UAV Identity	27
4.5.3 3GPP UAV ID	27

5	Functional description and information flows.....	27
5.1	Control and user plane stacks	27
5.2	UAV Authentication and Authorization.....	27
5.2.1	UAAA Model	27
5.2.2	UAAA at Registration in 5GS (UAAA-MM).....	28
5.2.2.1	General	28
5.2.2.2	UAAA-MM Procedure.....	31
5.2.3	UAAA At PDN Connection/PDU Session Establishment (UAAA-SM).....	33
5.2.3.1	General	33
5.2.3.2	USS UAV Authorization/Authentication (UAAA) during the PDU Session Establishment	34
5.2.3.3	USS UAV Authorization/Authentication (UAAA) during default PDN connection at Attach.....	36
5.2.4	UAAA Re-authentication and Re-authorization by USS/UTM.....	39
5.2.4.1	UAV Re-authentication procedure in 5GS.....	39
5.2.4.2	UAV Re-authentication procedure in EPS.....	40
5.2.4.3	USS initiated UAV Re-authorization procedure in 5GS.....	41
5.2.4.4	USS initiated UAV Re-authorization procedure in EPS	42
5.2.5	Authorization for C2 over Uu.....	43
5.2.5.1	General	43
5.2.5.2	Procedure for C2 authorization in 5GS.....	43
5.2.5.2.1	C2 Authorization request during UAAA-SM procedure in 5GS	43
5.2.5.2.2	UE initiated PDU Session Modification for C2 Communication	44
5.2.5.2.3	UE initiated PDU Session Establishment for C2 Communication	45
5.2.5.3	Procedure for C2 authorization in EPS	47
5.2.5.3.0	C2 Authorization request during UAAA-SM procedure in EPS	47
5.2.5.3.1	UE requested PDN connectivity for C2 authorization.....	48
5.2.5.3.2	UE requested bearer resource modification of an existing PDN connection for C2 authorization.....	49
5.2.5.4	USS initiated C2 pairing policy configuration	51
5.2.5.4.1	USS initiated C2 pairing policy configuration in 5GS	51
5.2.5.4.2	USS initiated C2 pairing policy configuration in EPS.....	52
5.2.6	Void	53
5.2.7	UAAA Revocation by USS/UTM	53
5.2.8	UAV Controller Replacement.....	54
5.2.8.1	UAV controller replacement in 5GS	54
5.2.8.2	UAV controller replacement in EPS	55
5.2.9	Revocation of C2 Connectivity.....	56
5.2.9.1	Revocation of C2 connectivity in 5GS.....	56
5.2.9.2	Revocation of C2 connectivity in EPS	57
5.3	UAV Tracking.....	58
5.3.1	UAV Tracking Model.....	58
5.3.1.1	UAV Location Reporting Mode.....	59
5.3.1.2	UAV Presence Monitoring Mode	59
5.3.1.3	List of Aerial UEs in a geographic area	59
5.3.2	Procedure for UAV location reporting.....	59
5.3.3	Procedure for UAV presence monitoring	60
5.3.4	Procedure for obtaining list of Aerial UEs in a geographic area.....	62
5.4	Direct C2 Communication.....	63
5.4.1	General.....	63
5.4.2	Authorization policy for A2X Direct C2 Communication service.....	63
5.4.3	Procedure for C2 authorization by the USS for using the A2X Direct C2 Communication service.....	63
5.4.3.1	General	63
5.4.3.2	Authorization of Direct C2 Communication service via UAAA-MM	63
5.4.3.3	Authorization of Direct C2 Communication service via UAAA-SM	64
5.4.4	Procedure for Direct C2 Communication establishment.....	65
5.5	Broadcast Remote ID	65
5.5.1	Broadcast Remote ID using PC5	65
5.5.2	Broadcast Remote ID using MBS.....	66
5.5.2.1	Policy/Parameter provisioning	66
5.5.2.2	Broadcast Remote ID reception via MBS	66
5.5.2.3	QoS handling.....	66
5.5.2.4	MBS service area mapping	66
5.6	Mechanisms for Detect and Avoid (DAA).....	66

5.6.1	Mechanisms for Detect and Avoid (DAA) based on PC5	66
5.7	Ground-based DAA for an Area.....	68
5.7.1	Functional Description.....	68
5.7.2	Procedures.....	70
5.8	Void.....	71
5.9	Void.....	71
5.10	Void.....	71
5.11	Void.....	71
6	Aircraft-to-Everything (A2X) services.....	72
6.1	Architecture model and concepts	72
6.1.1	General concept	72
6.1.2	Architectural reference model.....	73
6.1.2.1	PC5 and Uu based A2X architecture reference model	73
6.1.2.1.1	Non-roaming 5G System architecture for A2X communication over PC5 and Uu reference points	73
6.1.2.1.2	Roaming 5G System architecture for A2X communication over PC5 and Uu reference points	73
6.1.2.1.3	Inter-PLMN 5G System architecture for A2X communication over PC5 reference point	73
6.1.2.2	AF-based service parameter provisioning for A2X communication	73
6.1.2.3	MBS for Uu based A2X architecture reference model.....	74
6.1.2.4	Reference points.....	74
6.1.2.5	Service-based interfaces	74
6.1.3	Functional entities.....	74
6.2	High level functionality and features.....	74
6.2.1	Authorization and Provisioning for A2X communications.....	74
6.2.1.1	General	74
6.2.1.2	Authorization and Provisioning for A2X communications over PC5 reference point	74
6.2.1.2.1	Policy/Parameter provisioning	74
6.2.1.2.2	Principles for applying parameters for A2X communications over PC5 reference point.....	75
6.2.1.3	Authorization and Provisioning for A2X communications over Uu reference point	75
6.2.1.3.1	Policy/Parameter provisioning	75
6.2.2	A2X communication.....	75
6.2.2.1	A2X communication over PC5 reference point	75
6.2.2.1.1	General	75
6.2.2.1.2	Broadcast mode communication over PC5 reference point.....	75
6.2.2.1.3	Unicast mode communication over PC5 reference point	76
6.2.2.1.4	IP address allocation.....	76
6.2.2.2	A2X communication over Uu reference point	76
6.2.2.2.1	A2X communication via unicast	76
6.2.2.2.2	A2X reception via MBS	76
6.2.3	A2X Application Server discovery	76
6.2.4	QoS handling for A2X communication	76
6.2.4.1	QoS handling for A2X communication over PC5 reference point.....	76
6.2.4.2	QoS handling for A2X communication over Uu reference point.....	77
6.2.5	Subscription to A2X service	77
6.2.6	Identifiers.....	78
6.2.6.1	Identifiers for A2X communication over PC5 reference point	78
6.2.7	Interworking between EPS A2X and 5GS A2X	78
6.2.7.1	A2X Policy and parameter provisioning.....	78
6.2.7.2	PC5 operation.....	78
6.2.8	MBS Service Description for A2X use	78
6.3	Functional description and information flows.....	78
6.3.1	Control and user plane stacks for NR PC5 reference point supporting A2X services	78
6.3.1.1	User plane for PC5 reference point supporting A2X services.....	78
6.3.1.2	Control plane for NR PC5 reference point supporting A2X services	79
6.3.2	Procedures for A2X service authorization and provisioning to UE.....	79
6.3.2.1	General	79
6.3.2.2	PCF based A2X Service Authorization and Provisioning to UE	79
6.3.2.3	Procedure for UE triggered A2X Policy provisioning	80
6.3.2.4	AF-based service parameter provisioning for A2X communications over control plane.....	81
6.3.3	Procedures for A2X communication over PC5 reference point.....	81
6.3.3.1	Broadcast mode A2X communication over NR PC5 reference point	81

6.3.3.2	Unicast mode A2X communication over PC5 reference point	81
6.3.4	Procedures for A2X communication over Uu reference point.....	81
6.3.4.1	A2X Application server discovery using broadcast MBS session	81
6.3.4.2	Procedures for A2X communication with MBS	82
6.3.4.2.1	MBS service area mapping.....	82
6.3.5	Procedures for Service Authorization to NG-RAN for A2X communications over PC5 reference point.....	82
6.3.5.1	General	82
6.3.5.2	Registration procedure	82
6.3.5.3	Service Request procedure.....	83
6.3.5.4	N2 Handover procedure	83
6.3.5.5	Xn Handover procedure	83
6.3.5.6	Subscriber Data Update Notification to AMF.....	83
6.3.5.7	Delivery of PC5 QoS parameters to NG-RAN	84
Annex A (informative):	Change history	85
History		88

Foreword

This Technical Specification has been produced by the 3rd Generation Partnership Project (3GPP).

The contents of the present document are subject to continuing work within the TSG and may change following formal TSG approval. Should the TSG modify the contents of the present document, it will be re-released by the TSG with an identifying change of release date and an increase in version number as follows:

Version x.y.z

where:

- x the first digit:
 - 1 presented to TSG for information;
 - 2 presented to TSG for approval;
 - 3 or greater indicates TSG approved document under change control.
- y the second digit is incremented for all changes of substance, i.e. technical enhancements, corrections, updates, etc.
- z the third digit is incremented when editorial only changes have been incorporated in the document.

In the present document, modal verbs have the following meanings:

- shall** indicates a mandatory requirement to do something
- shall not** indicates an interdiction (prohibition) to do something

The constructions "shall" and "shall not" are confined to the context of normative provisions, and do not appear in Technical Reports.

The constructions "must" and "must not" are not used as substitutes for "shall" and "shall not". Their use is avoided insofar as possible, and they are not used in a normative context except in a direct citation from an external, referenced, non-3GPP document, or so as to maintain continuity of style when extending or modifying the provisions of such a referenced document.

- should** indicates a recommendation to do something
- should not** indicates a recommendation not to do something
- may** indicates permission to do something
- need not** indicates permission not to do something

The construction "may not" is ambiguous and is not used in normative elements. The unambiguous constructions "might not" or "shall not" are used instead, depending upon the meaning intended.

- can** indicates that something is possible
- cannot** indicates that something is impossible

The constructions "can" and "cannot" are not substitutes for "may" and "need not".

- will** indicates that something is certain or expected to happen as a result of action taken by an agency the behaviour of which is outside the scope of the present document
- will not** indicates that something is certain or expected not to happen as a result of action taken by an agency the behaviour of which is outside the scope of the present document
- might** indicates a likelihood that something will happen as a result of action taken by some agency the behaviour of which is outside the scope of the present document

might not indicates a likelihood that something will not happen as a result of action taken by some agency the behaviour of which is outside the scope of the present document

In addition:

is (or any other verb in the indicative mood) indicates a statement of fact

is not (or any other negative verb in the indicative mood) indicates a statement of fact

The constructions "is" and "is not" do not indicate requirements.

1 Scope

The present document specifies architecture enhancements for supporting Uncrewed Aerial Systems (UAS) connectivity, identification, and tracking, according to the use cases and service requirements defined in TS 22.125 [5].

The following functions are specified:

- UAV Identification, authentication and authorization.
- UAV tracking in the 3GPP system:
 - this includes how the 3GPP system can provide support for UAV to ground identification (e.g. to authorized third parties such as police devices).
- handling of unauthorized UAVs and revocation of authorization.

2 References

The following documents contain provisions which, through reference in this text, constitute provisions of the present document.

- References are either specific (identified by date of publication, edition number, version number, etc.) or non-specific.
- For a specific reference, subsequent revisions do not apply.
- For a non-specific reference, the latest version applies. In the case of a reference to a 3GPP document (including a GSM document), a non-specific reference implicitly refers to the latest version of that document *in the same Release as the present document*.

- [1] 3GPP TR 21.905: "Vocabulary for 3GPP Specifications".
- [2] 3GPP TS 23.501: "System architecture for the 5G System (5GS)".
- [3] 3GPP TS 23.502: "Procedures for the 5G System (5GS)".
- [4] 3GPP TS 23.222: "Common API Framework for 3GPP Northbound APIs".
- [5] 3GPP TS 22.125: "Unmanned Aerial System (UAS) support in 3GPP".
- [6] 3GPP TS 23.401: "General Packet Radio Service (GPRS) enhancements for Evolved Universal Terrestrial Radio Access Network (E-UTRAN) access".
- [7] 3GPP TS 36.300: "Evolved Universal Terrestrial Radio Access (E-UTRA) and Evolved Universal Terrestrial Radio Access Network (E-UTRAN); Overall description; Stage 2".
- [8] 3GPP TS 23.273: "5G System (5GS) Location Services (LCS); Stage 2".
- [9] 3GPP TS 23.503: "Policy and charging control framework for the 5G System (5GS); Stage 2".
- [10] 3GPP TS 33.256: "Security aspects of Uncrewed Aerial Systems (UAS)".
- [11] 3GPP TS 23.287: "Architecture enhancements for 5G System (5GS) to support Vehicle-to-Everything (V2X) services".
- [12] 3GPP TS 23.285: "Architecture enhancements for V2X services".
- [13] ASTM F3411.19: "Standard Specification for Remote ID and Tracking".
- [14] ASD-STAN prEN 4709-002:2022-03: "Aerospace series - Unmanned Aircraft Systems - Part 002: Direct Remote Identification".
- [15] 3GPP TS 38.300: "NR; NR and NG-RAN Overall description; Stage-2".

- [16] 3GPP TS 38.423: "NG-RAN; Xn Application Protocol (XnAP)".
- [17] 3GPP TS 23.247: "Architectural enhancements for 5G multicast-broadcast services; Stage 2".
- [18] 3GPP TS 26.502: "5G multicast-broadcast services; User Service architecture".
- [19] 3GPP TS 26.517: "5G Multicast-Broadcast User Services; Protocols and Formats".

3 Definitions and abbreviations

3.1 Definitions

For the purposes of the present document, the terms and definitions given in TR 21.905 [1] and the following apply. A term defined in the present document takes precedence over the definition of the same term, if any, in TR 21.905 [1] or TS 23.501 [2].

3GPP UAV ID: Identifier assigned by the 3GPP system and used by external AF (e.g. USS) to identify the UAV. GPSI is used as the 3GPP UAV ID.

A2X communication: A communication to support Aircraft-to-Everything (A2X) services leveraging PC5 and/or Uu reference points. A2X services are realized by various types of A2X applications.

A2X message: A dedicated messaging type of A2X service.

A2X service: A data service, offered to A2X applications and optionally A2X Application Servers. An A2X service belongs to one A2X service type. An A2X service can be associated with one or more A2X applications, and a A2X application can be associated with one or more A2X services.

A2X service type: A type of A2X service, which is identified by any one of ITS-AID (ITS Application Identifier), PSID (Provider Service Identifier) or AID (Application Identifier) according to values defined specifically for aviation applications.

NOTE 1: It is expected a dedicated set of A2X services will be defined with associated A2X service types. The definition of DAA/UAV service type is out of scope of 3GPP.

Application Layer ID: An identifier identifying an entity, e.g. a UAV, a UAV-C, within the context of a specific A2X application. These identifiers are used for Direct C2 Communication or for Direct Detect And Avoid. The format of this identifier is outside the scope of 3GPP.

NOTE 2: The Application Layer ID could be e.g. CAA-Level UAV ID for UAV defined by other SDOs e.g. ASTM, etc.

Area Airspace Manager (AAM): A ground-based entity that is responsible for managing the airspace for a specific area/arena so that correspondingly residing UAVs are prevented to collide with each other and with other physical objects. For this purpose, AAM is able to detect UAVs residing in the specific airspace and provide policies for collision avoidance to the corresponding UASs. The AAM acts as a TPAE having specific abilities for direct communication with UAVs relevant for the applicable airspace and it includes one or more UEs enabled for use of PC5.

Broadcast Remote ID: The capability of providing Remote Identification and Tracking over broadcast radio links.

NOTE 3: In the scope of this release, the radio link for Broadcast Remote ID is assumed to utilize radio technologies outside the scope of 3GPP.

CAA (Civil Aviation Administration)-Level UAV Identity: a UAV identity assigned by USS/UTM, and uniquely identifies a UAV at least within the scope of a USS.

Command and Control (C2) Communication: the user plane link to deliver messages with information of command and control for UAV operation from a UAV controller or a UTM to a UAV or to report telemetry data from a UAV to its UAV controller or a UTM. C2 communication may be over Uu reference point or PC5 reference point.

C2 Aviation Payload: Contains application layer information sent by the UAS to the USS containing UAV pairing information and/or flight authorization information that is transparent to the 3GPP System.

C2 Authorization Payload: Contains application layer information sent by the USS to the UAV containing e.g. C2 pairing information and/or C2 security information that is transparent to the 3GPP System.

C2 Pairing Information: Contains UAV-C Addressing Information which may e.g. include the UAV-C IP Address.

Detect And Avoid: The capability to see, sense or detect conflicting traffic or other hazards and take the appropriate action.

Direct Detect And Avoid: DAA that leverages communications over PC5 reference point.

Direct C2 Communication: the UAV controller and UAV establish a direct C2 link over PC5 reference point to communicate with each other.

Networked UAV Controller: a UAV Controller connected to the 3GPP network and connected to the UAV via a 3GPP network.

Non-Networked UAV Controller: a UAV Controller not connected to the 3GPP network and connected to UAV via a transport outside the scope of 3GPP, e.g. internet connectivity or direct wireless communication over a technology outside the scope of 3GPP.

Networked Remote ID: The capability of providing Remote Identification and Tracking to a USS over 3GPP network.

Remote Identification (Remote ID) of UAS: The ability of a UAS in flight to provide identification and tracking information that can be received by other parties, to facilitate advanced operations for the UAS (such as Beyond Visual Line of Sight operations as well as operations over people), assist regulatory agencies, air traffic management agencies, law enforcement, and security agencies when a UAS appears to be flying in an unsafe manner or where the UAS is not allowed to fly. The Remote ID information payload may include Serial Number or Session ID assigned to the UAV, location of the ground-station controller, emergency status indication, etc.

Third Party Authorized Entity: is either a privileged Networked UAV Controller, or a privileged Non-Networked UAV Controller, or another entity which gets information on sets of UAV controllers and UAVs from the 3GPP network, and may be connected to the UAV via the Internet; it may be authorized by the UTM to interface with sets of UAV(s).

UAS NF: a 3GPP UAS Network Function for support of aerial functionality related to UAV identification, authentication/authorization and tracking, and to support Remote Identification.

UAS Service Supplier (USS): An entity that provides services to support the safe and efficient use of airspace by providing services to the operator / pilot of a UAS in meeting UTM operational requirements. A USS can provide any subset of functionality to meet the provider's business objectives (e.g. UTM, Remote Identification). In the scope of this specification, the term USS refers to both USS and USS/UTM.

UAS Traffic Management (UTM): a system that can safely and efficiently integrate the flying UAV along with other airspace users. It provides a set of functions and services for managing a range of autonomous vehicle operations (e.g. authenticating UAV, authorizing UAS services, managing UAS policies, and controlling UAV traffics in the airspace).

UAV controller: The UAV controller of a UAS enables a drone pilot to control an UAV.

UAV operator: the entity owning and operating a UAV.

UAS Container: A container to the 3GPP system that includes UUAA Aviation/Authorization Payload and/or C2 Aviation/Authorization Payload. The internal content of the individual payloads is transparent to the 3GPP system.

UAS Services: refers to establishment of connectivity for a UAS for communication with USS, for C2, for remote identification, and for UAV location and tracking.

USS communication: A communication between a UAV and a USS other than C2 communication, by means of user plane data transmission for some UAS Services.

NOTE 4: The PDU session/PDN connection for C2 communication and the PDU session/PDN connection for USS communication can be common or separate.

UUAA Authorization Payload: Contains application layer information optionally including UUAA result for UAV consumption provided by the USS to the UAS which is transparent to the 3GPP System.

UUAA Aviation Payload: Contains application layer information provided by the UAS to USS and is transparent to the 3GPP System

Uncrewed Aerial System (UAS): Composed of Uncrewed Aerial Vehicle (UAV) and related functionality, including command and control (C2) links between the UAV and the control station, the UAV and the network, and for remote identification. An UAS may comprise of a UAV and a UAV controller.

Unknown UAVs: A list of the UAVs to be identified in the target area and served by the PLMN as the result of the UAV tracking requested by USS/UTM.

UUAA: UAV USS authentication and authorization procedure of the UAV to ensure that the UAV has successfully registered with a USS and has therefore been authorized for operations by the USS. An UAV is authenticated and authorized by USS via a UUAA procedure with the support of the 3GPP system before connectivity for UAS services is enabled.

UUAA-MM: the UUAA procedure optionally performed during registration to a 5GS.

UUAA-SM: the UUAA procedure performed during the establishment of a PDU session and performed during the establishment of a PDN connection.

For the purposes of the present document, the following terms and definitions given in TS 23.287 [11] apply:

NR Tx Profile

Intelligent Transport Systems

ITS Application Identifier

Provider Service Identifier

Application Identifier

3.2 Abbreviations

For the purposes of the present document, the abbreviations given in TR 21.905 [1] and the following apply. An abbreviation defined in the present document takes precedence over the definition of the same abbreviation, if any, in TR 21.905 [1].

A2X	Aircraft-to-Everything
AAM	Area Airspace Manager
BRID	Broadcast Remote Identification
BVLOS	Beyond Visual Line of Sight
C2	Command and Control
DAA	Detect And Avoid
DDAA	Direct Detect And Avoid
MBS	Multicast/Broadcast Service
NRID	Networked Remote Identification
PQI	PC5 5QI
RID	Remote Identification
TPAE	Third Party Authorized Entity
UAS	Uncrewed Aerial System
UAV	Uncrewed Aerial Vehicle
UAV-C/UAVC	Uncrewed Aerial Vehicle Controller
USS	UAS Service Supplier
UTM	Uncrewed Aerial System Traffic Management
UUAA	USS UAV Authorization/Authentication
UUID	Universal Unique Identifier

4 Architecture model and concepts

4.1 General concept

The architecture enhancements for UAVs introduce the following functionalities:

- Authentication and authorization of a UAV with the USS during 5GS registration (optional).
- Authentication and authorization of a UAV with the USS during PDU session establishment and PDN connection establishment.
- Support for USS authorization of C2 Communication.
- A reference model for UAV tracking, supporting three UAV tracking modes: UAV location reporting mode, UAV presence monitoring mode, and list of Aerial UEs in a geographic area. The 3GPP system supports geofencing (for in-flight UAV) and geocaging (for UAV on the ground intending to fly) functionality in USS by providing enablers such as location services, event notification to a subscribing USS, etc.

NOTE: Geofencing/geocaging mechanisms are an air traffic control functionality performed by the USS and are out of scope of this specification. The 3GPP system provides enablers to support geofencing/geocaging functionality in USS, e.g. location services, enablement of C2 connectivity, event notification to a subscribing USS, etc. However, no specific geofencing/geocaging mechanisms are defined in 3GPP.

- Support for Broadcast Remote ID using MBS.
- Support for Direct C2 Communication.
- Support for Detect and Avoid mechanisms based on PC5 reference point.
- Support for Broadcast Remote ID using PC5 reference point.

4.2 Architectural reference model

4.2.1 General

4.2.1.1 Support for general UAV features

This specification covers UAV functionality provided by 5GC connected to NG-RAN and EPC connected to LTE.

The following functionality is defined for UAV support in the 3GPP system:

- An UAV is authenticated and authorized by USS via a USS UAV Authentication & Authorization (UUAA) with the support of the 3GPP system before connectivity for UAS services is enabled.
- Depending on 3GPP network operator and/or regulatory requirements, the UUAA is performed:
 - In 5GS: either as a separate procedure during the 5GS registration procedure (optional and based on specific PLMN policies, USS requirements, and geographic regulatory requirements), or when the UAV requests user plane resources for UAV operation (i.e. PDU session establishment). The UAV shall support UUAA during Registration and PDU session establishment procedure. The network shall support UUAA during PDU session establishment.
 - In EPS: during the attach procedure and the corresponding PDN connection establishment. The network shall support UUAA during PDN connection establishment. The UAV shall support UUAA during PDN connection establishment procedure.
- A UAV that is provisioned with a CAA-Level UAV ID shall provide the CAA-Level UAV ID in 5GS in both Registration and in PDU Session establishment. In EPC, a UAV that is provisioned with a CAA-Level UAV ID provides the CAA-Level UAV ID in PDN Connection establishment in SM-PCO. The CN determine whether UUAA is executed at 5GS registration or at PDU session/PDN Connection establishment, based on local policies.

- The UUAA is performed at PDU session establishment when the UAV requests user plane resources for UAV operation and the UAV provides its CAA Level ID during PDU session (PDN connection) establishment.
- The UAV flight authorization and UAV-UAVC pairing authorization is performed at PDU session/PDN connection establishment/modification procedures.
- The 3GPP system supports USS authorization of pairing between a UAV and a networked UAVC or a UAVC that connects to the UAV via Internet connectivity during either the establishment of the PDN connection/PDU session for C2 communication or a modification of a PDN connection/PDU session either dedicated to C2 communication or common to USS communication and C2 communication. Modifications of the pairing or re-authorization take place via modification of the established PDN connection/PDU session. During such procedures, the USS provides to the 3GPP system information (e.g. QoS requirement, data flow descriptors, etc.) that enable traffic between the UAV and the UAVC.

NOTE 1: How the USS is made aware of the UAVC is outside the scope of 3GPP in this Release.

- For EPC, the PDN connections used by UAV are served by SMF+PGW-C regardless of whether the UAV support 5G NAS or whether their subscription allows access to 5GC. The APN(s) used by the UAV for contacting USS or for C2 communication always resolves to a SMF+PGW-C.

The following architectural assumptions apply:

- It is assumed that the UAV trying to access UAS services using 3GPP connectivity is already registered with a USS and has been assigned a CAA-Level-UAV ID. The procedure for UAV registration and assignment of CAA-Level-UAV ID is out of scope of 3GPP. The USS assigns to the UAV a CAA-Level UAV ID, or is made aware of the assigned CAA-Level UAV ID.
- A UAV is associated with an Aerial subscription in the UDM. The Aerial subscription contains aerial UE indication in the Access and Mobility Subscription data (to be used similarly to aerial UE indication defined in EPS), an aerial service indication in the Session Management Subscription data for each DNN dedicated for UAS services (C2 and UUAA-SM) which indicates that corresponding authentication/authorization has to be done using API based mechanism.
- An UAV is identified by USS using a CAA-level UAV ID, and identified by the 3GPP System using a 3GPP UAV ID assigned by the MNO:
 - It is assumed that an aerial subscription associated to a UAV includes at least one GPSI to be used as 3GPP UAV ID.
- A UAV is registered with the USS either before connecting with the 3GPP system or using plain internet connectivity via the 3GPP system. Before registering for UAS services with the 3GPP system, the UAV shall be provisioned with a CAA-Level UAV Identity.
- In roaming scenarios, it is assumed that access to USS is in the VPLMN, thus packet data connectivity for UAV-USS communication is in local breakout, and the UAS NF function is located in the VPLMN.
- In this Release, the UAV uses 3GPP access (i.e. LTE & NR) for 3GPP UAV related operations.
- Activation of RAN aerial features for UAV accessing via E-UTRA reuses the existing mechanism defined in TS 36.300 [7].

NOTE 2: In this Release, an UAV is served by single USS for the duration of the connectivity between the USS and the UAV.

- One or more USS(s) may be present in a specific region and may manage UAVs over one or more 3GPP networks.
- The 3GPP Network subscription for the UAV is not assumed to contain any information about the USS.
- The USS address, if known to the UAV, is configured in the UAV via mechanisms outside the scope of 3GPP.
- For PC5, Release 15 (and later) version of the specification is the baseline.

NOTE 3: In this Release, UAV UE uses A2X capability to support the PC5 based DAA and BRID.

4.2.1.2 Void

4.2.2 Logical UAV Reference Architecture

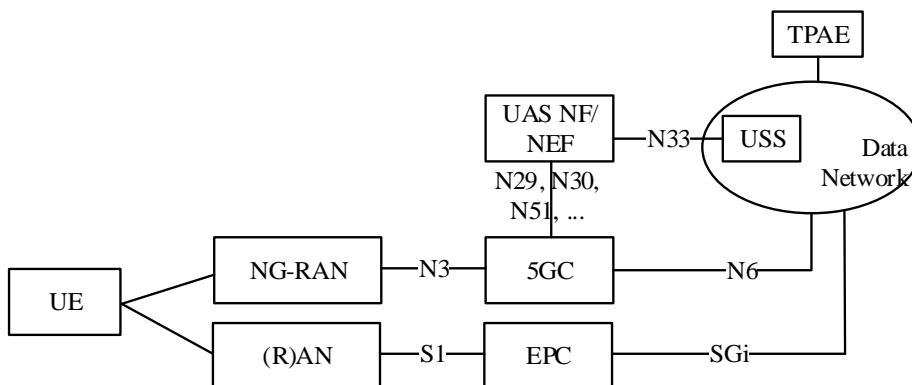

Figure 4.2.2-1: Logical 5GS and EPS architecture for UAV

NOTE 1: Provisioning of UAS services over EPC is based on the use of an SMF+PGW-C node.

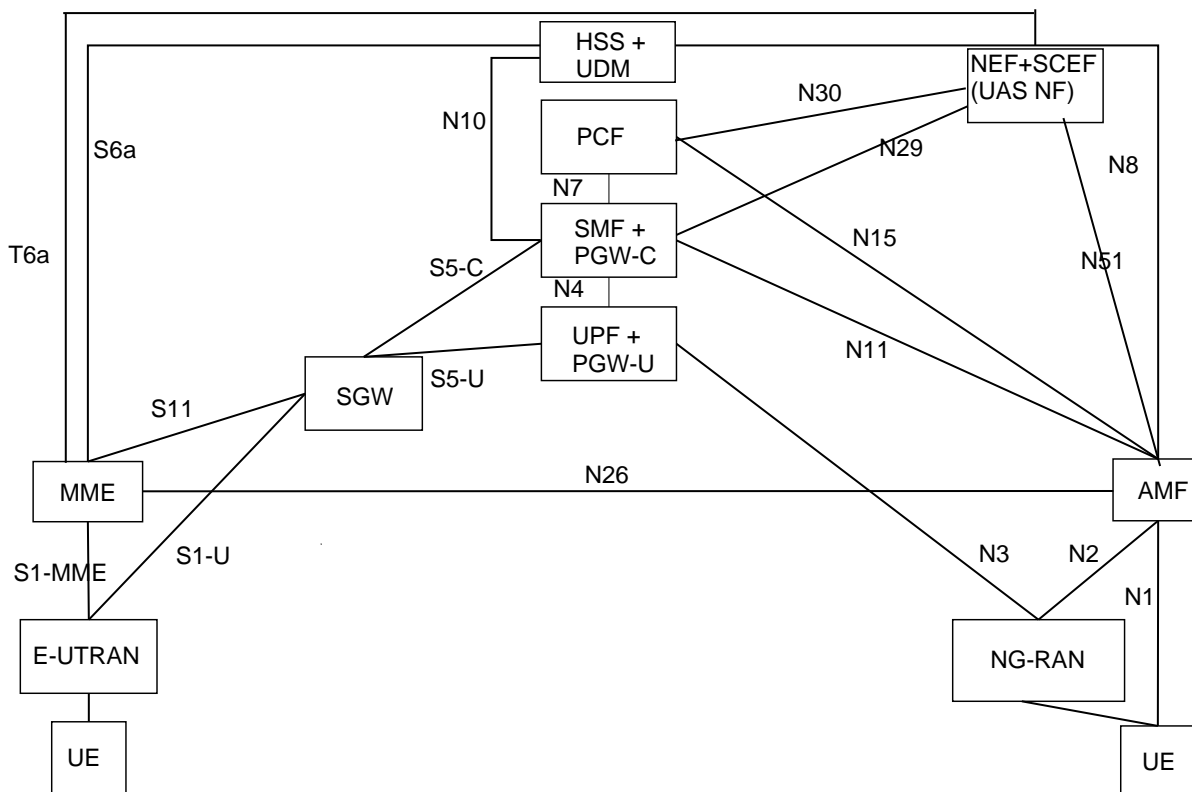

Figure 4.2.2-2: Non-roaming architecture for interworking between 5GS and EPC/E-UTRAN

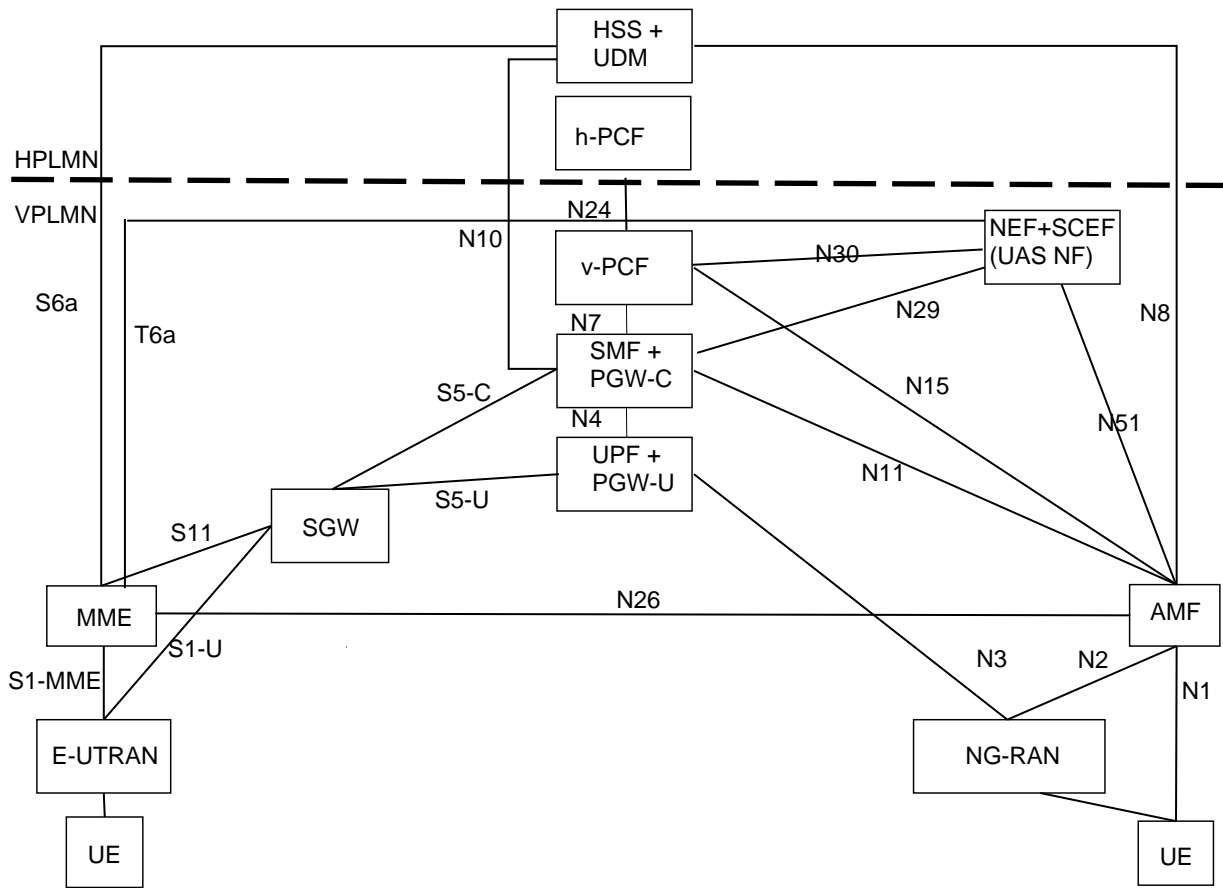

Figure 4.2.2-3: Local breakout roaming architecture for interworking between 5GS and EPC/E-UTRAN

NOTE 2: Transferring the UUAA context from AMF to MME when the UE moves from 5GS to EPS and the UUAA was performed at 5GS registration is not supported on the N26 interface.

NOTE 3: No new UAV-specific functionality is defined for T6a.

4.2.3 5GS Non-roaming Reference Architecture

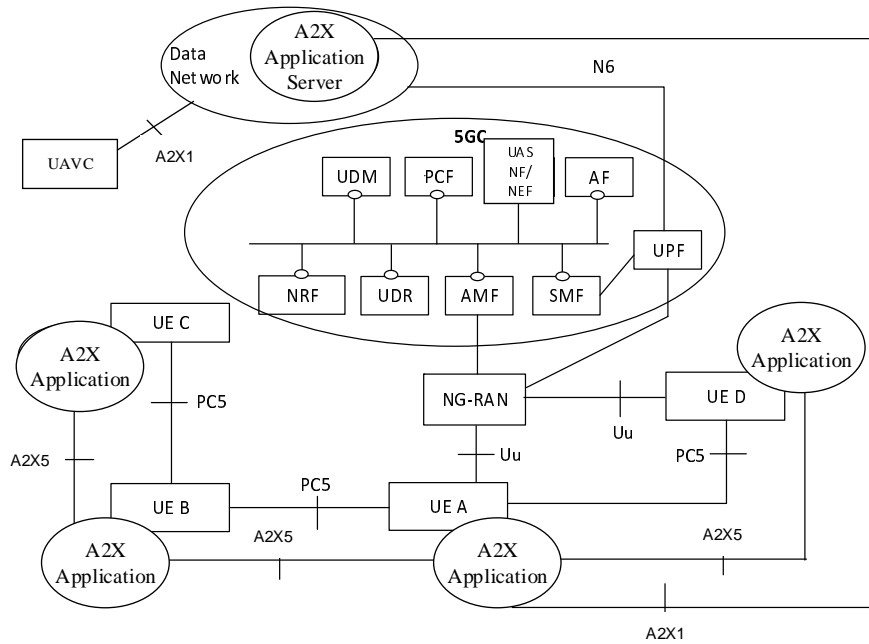

Figure 4.2.3-1: 5G System non-roaming architecture for UAVs and for A2X communication over PC5 and Uu reference points

4.2.4 5GS Roaming Reference Architecture

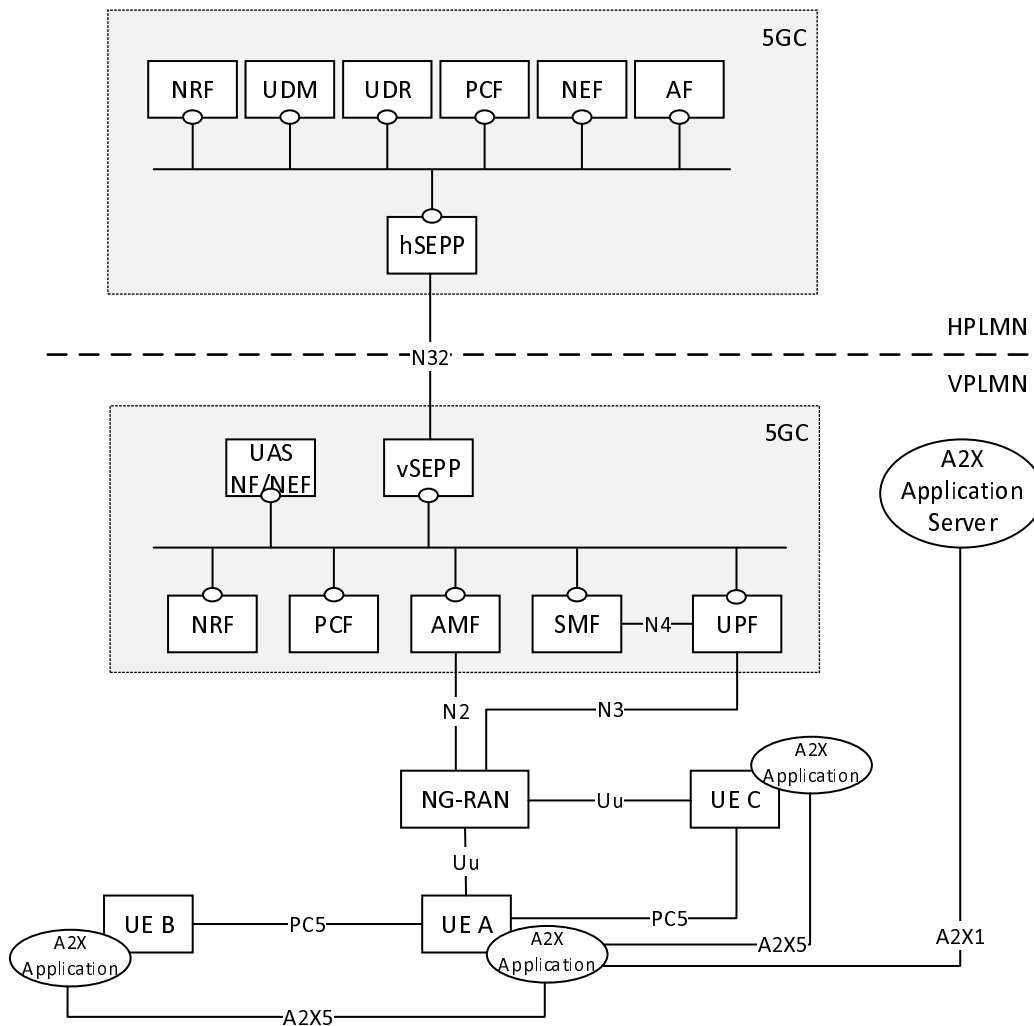

Figure 4.2.4-2: Roaming 5G System architecture for UAVs and for A2X communication over PC5 and Uu reference points - local breakout scenario in service-based interface representation

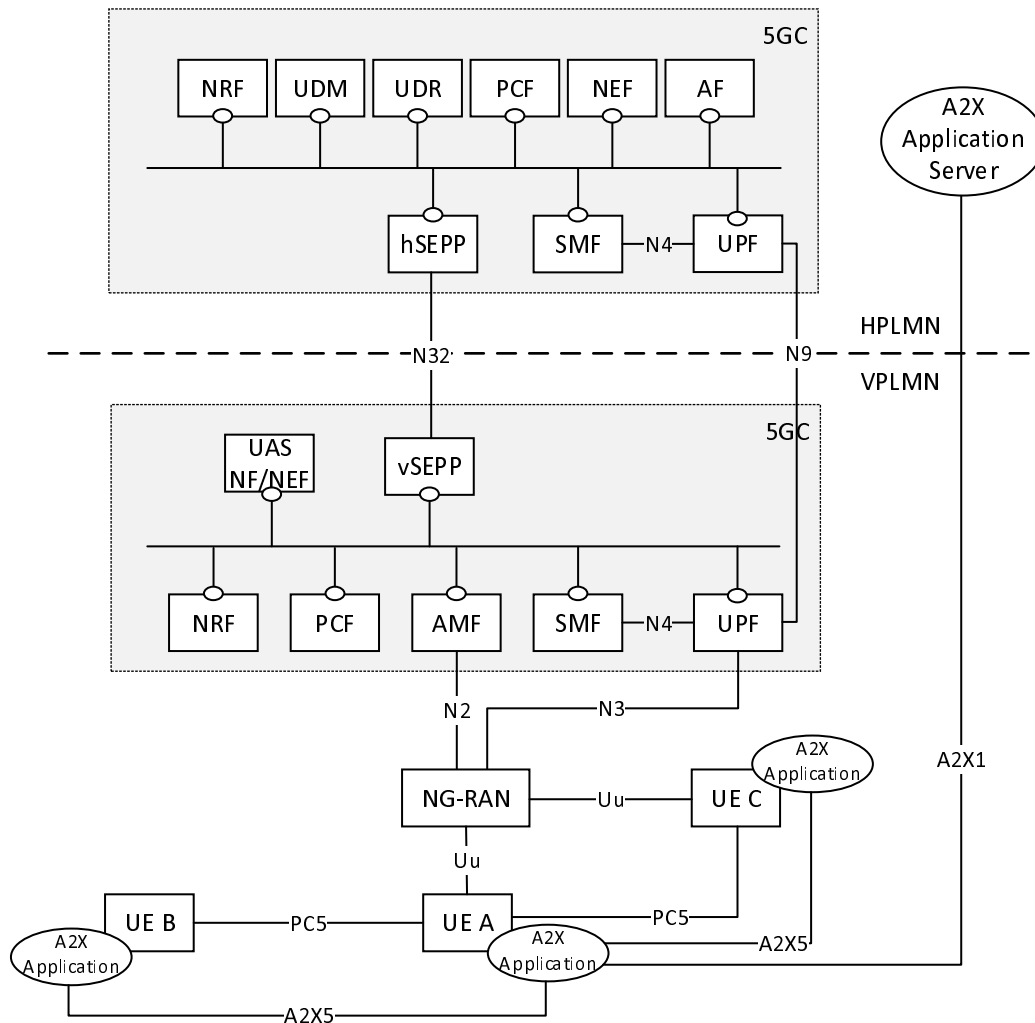

Figure 4.2.4-2: Roaming 5G System architecture for UAVs and for A2X communication over PC5 and Uu reference points - Home routed scenario

4.2.4A Void

4.2.5 Service-based interfaces

The 5G System Architecture for UAVs contains the service-based interfaces defined in TS 23.501 [2], with the following differences:

- Nudm:** In the case of A2X Service, services provided by UDM are used to get A2X Service related subscription information to AMF during Initial registration procedure or UE Configuration Update (UCU) procedure to inform AMF subscription information has changed.
- Npcf:** In the case of A2X Service, services provided by H-PCF are used to provide A2X Service related parameters to V-PCF for UE and NG-RAN in the roaming case.
- Nudr:** In the case of A2X Service, services provided by UDR are used to notify the PCF and the UDM of the update of the A2X Service related information.
- Nnef:** In the case of A2X Service, services provided by NEF are used by the A2X Application Server to update A2X Service related information of 5GC.

Namf: In the case of A2X Service, services provided by AMF are consumed by PCF to provide the A2X Service related parameters for the UE and the NG-RAN to AMF, and to enable the AMF create or update UE context related to A2X service.

Nnrf: In the case of A2X Service, services provided by NRF are used to discover the PCF that supports A2X.

4.2.6 Reference points

The 5G System Architecture for UAV contains the reference points defined in TS 23.501 [2]. In addition, the reference points of TS 23.287 [11] apply, with the following differences:

A2X1: The reference point between the A2X applications in the UAV UE and in the UAV-C, and the A2X Application Server. This reference point is out of scope of this specification.

A2X5: The reference point between the A2X applications in the UEs. This reference point is not specified in this release of the specification.

N1: In addition to the relevant functions defined in TS 23.501 [2] for N1, in the case of A2X Service it is also used to convey the A2X Policy and parameters (including service authorization) from AMF to UE and to convey the UE's A2X Capability and PC5 Capability for A2X information from UE to AMF.

N2: In addition to the relevant functions defined in TS 23.501 [2] for N2, in the case of A2X Service it is also used to convey the A2X Policy and parameters (including service authorization) from AMF to NG-RAN.

4.3 Functional entities

4.3.1 General

In addition to the 5GS functional entities defined in TS 23.501 [2] and the EPS functional entities defined in TS 23.401 [6], the following functional entities are defined for UAS.

4.3.2 UAS NF

The UAS Network Function is supported by the NEF or SCEF+NEF and used for external exposure of services to the USS. The UAS-NF makes use of existing NEF/SCEF exposure services for UAV authentication/authorization, for UAV flight authorization, for UAV-UAVC pairing authorization, and related re-authentication/re-authorization and revocation; for location reporting, presence monitoring, obtaining list of Aerial UEs in a geographic area and control of QoS/traffic filtering for C2 communication.

The UAS NF may coordinate with the USS to assist CAA-Level UAV ID assignment.

A dedicated NEF may be deployed to provide only the UAS NF functionality, i.e. to support the UAS specific features/APIs and the NEF features/APIs that are specified for capability exposure towards the USS.

For external exposure of services related to specific UAV(s), the UAS NF resides in the VPLMN, in order to interface with country specific USS(es).

When CAPIF is supported by the UAS NF, the UAS NF supports the CAPIF API provider domain functions as specified in TS 23.222 [4].

To support re-authentication/re-authorization and revocation request by USS, the UAS NF stores information as to whether the re-authentication/re-authorization and revocation is towards an AMF or SMF/SMF+PGW-C and the address of the serving AMF or SMF/SMF+PGW-C.

UAS NF stores the result of UUAA-MM procedures and the result of UUAA-SM procedures.

4.3.3 UAV

The UAV is a 3GPP UE supporting the UE functionality defined in TS 23.401 [6] and in TS 23.501 [2].

In addition:

- a UAV that is configured for UAS services is provisioned with a single CAA-Level UAV ID;
- a UAV that is configured for UAS services (i.e. is provisioned with a CAA-Level UAV ID) registers to the 3GPP system for UAS services (i.e. to take advantage of aerial features, connectivity with USS and for C2 connectivity) and provides the CAA-Level UAV ID and a UUAA Aviation Payload to 5GS or EPS. A UAV that has not performed a registration with aviation authorities shall not attempt to request for UAS services.

NOTE: A UAV that is configured for UAS services but does not have an aerial subscription is not allowed by the network to register for UAS services.

- a UAV that is configured for UAS services may support the following functions:
 - reports the A2X Capability and PC5 Capability for A2X (i.e. LTE PC5 and/or NR PC5) to 5GC over N1 reference point.
 - indicates A2X Policy Provisioning Request in UE Policy Container for UE triggered A2X Policy provisioning.
 - receives the A2X parameters from 5GC over N1 reference point.
 - supports procedures for A2X communication over PC5 reference point.
 - Configuration of parameters for A2X communication. These parameters can be pre-configured in the UE, or, if in coverage, provisioned or updated by signalling over the N1 reference point from the PCF in the HPLMN or over A2X1 reference point from the A2X Application Server.
 - Provided with the following for receiving Broadcast Remote ID via MBS:
 - Announcement via existing announcement mechanisms specified in TS 23.247 [17], TS 26.502 [18] and TS 26.517 [19]; or
 - MBS session announcement provisioned as specified in clause 6.2.1.3.1.
 - Provisioned with MBS session announcement for receiving A2X Application Server information via MBS as specified in clause 6.2.1.3.1.

4.3.4 AMF

In addition to the functionality defined in TS 23.501 [2], the AMF:

- may trigger the UUAA-MM procedure for a UE requiring UAV authentication and authorization by a USS when registering with 5GS when the UE has Aerial UE subscription information and based on local operator policy, or when the USS that authenticated the UAV triggers a re-authentication, or when AMF itself determines to re-authentication the UAV after the initial registration.

An AMF supporting A2X additionally performs the following functions:

- Obtain from UDM the subscription information related to A2X and store them as part of the UE context data.
- Select a PCF supporting A2X Policy/Parameter provisioning and report the PC5 Capability for A2X to the selected PCF.
- Obtain from PCF the PC5 QoS information related to A2X and store it as part of the UE context data.
- Provision the NG-RAN with indication about the UE authorization status about A2X communication over PC5 reference point.
- Provision the NG-RAN with PC5 QoS parameters related to A2X communication.

4.3.5 SMF

In addition to the functionality defined in TS 23.501 [2], the SMF:

- triggers the UUAA-SM procedure for a UE requiring UAV authentication and authorization by a USS when requesting user plane resources for UAV operation, or when the USS/UTM that authenticated the UAV triggers a re-authentication;
- may trigger the authorization of pairing between a UAV and a networked UAVC or a UAVC that connects to the UAV via Internet connectivity during the establishment/modification of the PDN connection/PDU session for C2 communication.

4.3.6 SMF+PGW-C

The SMF+PGW-C implements the functions of the SMF described in clause 4.3.5.

4.3.7 PCF

In addition to the functions defined in TS 23.501 [2], the PCF includes the functions described in 23.287 [11] to provision the UE and AMF with necessary parameters in order to use A2X communication.

4.3.8 UDM

In addition to the functions defined in TS 23.501 [2], the UDM performs subscription management for A2X communication over PC5 reference point.

4.3.9 A2X Application Server

The A2X Application Server implements a subset of the V2X AS functionality specified in clause 4.4.3 of TS 23.287 [11]:

- includes AF functionality, and may support at least the following capabilities:
 - For A2X service parameters provisioning, the A2X AS provides the 5GC and the UAV UE (possibly via the UAVC) with parameters for A2X communications over PC5 reference point and parameters for A2X communications over MBS.
 - Act as an AF/AS in clause 5.1 and Annex A of TS 23.247 [17] e.g. request NEF/MBSF for allocation/de-allocation of a set of TMGIs, initiate broadcast service from the 5GC by providing service information including QoS requirement to 5GC.
 - Perform MBS service area mapping as specified in clause 5.5.2.4.

NOTE: The A2X AS and the USS serving a UAV can be the same or different entities.

4.3.10 UDR

In addition to the functions defined in TS 23.501 [2], the UDR stores A2X service parameters.

4.3.11 NRF

In addition to the functions defined in TS 23.501 [2], the NRF performs PCF discovery by considering A2X capability.

4.4 High level function

4.4.1 Service Operations

4.4.1.1 NEF Services

4.4.1.1.1 General

In addition to those defined in TS 23.501 [2] clause 7.2.8 and TS 23.502 [3] clause 5.2.6, the following table illustrates additional NEF services to support UAS.

Table 4.4.2.1.1-1: NF Services provided by NEF

Service Name	Service Operations	Operation Semantics	Example Consumer(s)
Nnef_Authentication	AuthenticateAuthorize	Request/Response	AMF, SMF
	Notification	Subscribe/Notify	AMF, SMF

4.4.1.1.2 Nnef_Authentication service

4.4.1.1.2.1 General

Service Description: This service enables the consumer to either authenticate and authorise, or just authorize, the Service Level Device Identity. In case of UAS, the service is used to authenticate and/or authorize the UAV identified by a CAA-Level UAV ID.

When creating an authentication session, the AMF/SMF implicitly subscribes to NEF about notification related with the authentication/authorization (e.g. re-authenticate, update authorization data or revoke the UUAA authorization). This implicit subscription is implicitly released by UAS NF/NEF when the corresponding authentication association is removed (e.g. in the case of re-authentication failure and USS indicating to release network resource, or in the case of authorization revocation).

4.4.1.1.2.2 Nnef_Authentication_AuthenticateAuthorize service operation

Service operation name: Nnef_Authentication_AuthenticateAuthorize

Description: Provides the authentication and authorization result of the Service Level device Identity.

Input, Required: Service Level Device Identity (i.e. CAA-Level UAV ID) for authentication, GPSI, NF Type.

Input, Conditional Required: Notification endpoint (required for initial authentication request), DNN, S-NSSAI (in case the consumer NF is SMF).

Input, Optional: Authorization Server Address (i.e. USS Address), PEI, UE IP address (in case the consumer NF is SMF), authentication/authorization container provided by UE, UAV location.

Output, Required: None.

Output, Conditional Required: Success/Failure indication [Not required when PDU Session Modification for C2 Communication], Authorization Data container, Indication whether the PDU sessions associated with the "DNN(s) subject to aerial services" can be released [Required for re-authentication failure].

Output, Optional: None.

4.4.1.1.2.3 Nnef_Authentication_Notification service operation

Service operation name: Nnef_Authentication_Notification

Description: Re-authenticate, update authorization data or revoke the UUAA authorization of a UAV.

NOTE: This notification corresponds to an implicit subscription by Nnef_Authentication_AuthenticateAuthorize service operation.

Input, Required: Notification Correlation Information, Service Level Device Identity, 3GPP UAV ID, Notify reason (revoke, re-authentication, or authorization data update).

Input, Conditional Required: Authorization Data container (if the Notify reason is authorization data update).

Input, Optional: None.

Output, Required: Acknowledge indication.

Output, Optional: None.

4.4.1.2 AF Services

4.4.1.2.1 General

In addition to the AF services defined in TS 23.501 [2] clause 7.2.19 and TS 23.502 [3] clause 5.2.19, the following table shows the AF services to support UAS.

Table 4.4.1.2.1-1: NF Services provided by AF

Service Name	Service Operations	Operation Semantics	Example Consumer(s)
Naf_Authentication	AuthenticateAuthorize	Request/Response	UAS NF/NEF
	Notification	Subscribe/Notify	UAS NF/NEF

4.4.1.2.2 Naf_Authentication service

4.4.1.2.2.1 General

Service Description: This service enables the consumer to authenticate and authorize the Service Level Device Identity. In case of UAS, the service is used to authenticate and authorize the UAV identified by a CAA-Level UAV ID.

When creating an authentication session, the UAS NF/NEF implicitly subscribes to USS about notification related with the authentication/authorization (e.g. re-authenticate, update authorization data or revoke the UUAA authorization). This implicit subscription is implicitly released by USS when the corresponding authentication session is removed (e.g. in the case of re-authentication failure and USS indicating to release network resource, or in the case of authorization revocation).

4.4.1.2.2.2 Naf_Authentication_AuthenticateAuthorize service operation

Service operation name: Naf_Authentication_AuthenticateAuthorize

Description: Provides the Authentication and Authorization result of the Service Level Device Identity (i.e. CAA-Level UAV ID for UAS).

Input, Required: Service Level Device Identity for authentication, GPSI.

Input, Optional: Notification endpoint (required for initial authentication request), PEI, UE IP address, authentication container provided by UE, UAV location.

Output, Required: None.

Output, Conditional Required: Success/Failure indication and GPSI [Not required when PDU Session Modification for C2 Communication], Authorization Data container, Indication whether the UAS service related network resource can be released [Required for re-authentication failure]

Output, Optional: None.

4.4.1.2.2.3 Naf_Authentication_Notification service operation

Service operation name: Naf_Authentication_Notification

Description: Re-authenticate, update authorization data or revoke the UUAA authorization of a UAV.

NOTE: This notification corresponds to an implicit subscription by Naf_Authentication_AuthenticateAuthorize service operation.

Input, Required: Notification Correlation Information, Service Level Device Identity, GPSI, Notify reason (revoke, re-authentication, or authorization data update).

Input, Conditional Required: Authorization Data container (if the Notify reason is authorization data update).

Input, Optional: PDU Session IP address.

Output, Required: Acknowledge indication.

Output, Optional: None.

4.4.1.3 AMF Services

AMF services related to UAS are defined in TS 23.502 [3] clause 5.2.2.

In addition, when SMF invokes Namf_Communication_N1N2MessageTransfer service operation, it may provide the UUAA result to the UAV.

4.4.1.4 SMF Services

SMF services related to UAS are defined in TS 23.502 [3] clause 5.2.8.

4.4.1.5 UDM Services

UDM services related to UAS are defined in TS 23.502 [3] clause 5.2.3.

4.4.1.6 LMF Services

LMF services related to UAS are defined in TS 23.273 [8] clause 8.3.

4.4.1.7 GMLC Services

GMLC services related to UAS are defined in TS 23.273 [8] clause 8.4.

4.4.1.8 UDR Services

UDR services related to UAS are defined in TS 23.502 [3] clause 5.2.12.

4.4.1.9 PCF Services

PCF services related to UAS are defined in TS 23.502 [3] clause 5.2.5.

4.4.2 USS Discovery

There may be multiple USS(es) serving UASs in a country, and no direct association is expected between the 3GPP network serving a UAS and the USS providing services to the UAS. How the association between a UAV and a USS is realized, is outside the scope of 3GPP and is not related to the UAV subscription with the mobile operator.

In order to enable the interaction between the 3GPP network and the USS serving a UAS, the 3GPP network needs to discover the correct USS serving a specific UAV. This is required either during 5GS registration (when the UUAA is performed during 5GS registration), or during PDU session/PDN connection establishment.

It is assumed that mechanisms for resolution of CAA Level UAV ID to the USS serving the corresponding UAV, defined outside 3GPP, and available to entities outside the 3GPP system (e.g. the TPAAE), are used in the 3GPP system to discover the USS for the UAV.

Optionally, the UAV may also provide to the 3GPP system, in addition to the CAA-level UAV ID, the USS address (USS IP address or USS FQDN) in order to discover the USS for the UAV.

When the UAV provides the USS address (i.e. USS FQDN) separately from the CAA-Level UAV ID in UUAA-MM or UUAA-SM, the USS address (i.e. USS FQDN) shall be used to discover the USS. The USS address, when available, is used by the UAS NF in addition to CAA-Level UAV ID to discover a specific USS.

NOTE: A USS, of which the address is provided by the UE, is assumed accessible to any UAS NF/NEF in the 3GPP network.

4.4.3 CAA-Level UAV ID Assignment

The format of the CAA-Level UAV ID is defined outside 3GPP, however how such identity is used to enable a TPAAE to query about UAV information is defined with respect to the 3GPP functionality.

In this release, the assignment of a CAA-level UAV ID for Remote Identification functionality applies solely to the UAV. No CAA-level UAV ID is assigned to and used by a UAVC.

Various formats of CAA-level UAV ID must be supported by the UAV to support various geo-specific regulations. At least Serial Number Identification, a CAA-Issued Registration Identifier (aka Session ID), and USS Issued UUID shall be supported.

In the case of Session ID, though the actual format of the CAA-Level UAV ID is defined outside 3GPP and is not decided by 3GPP, it is assumed that the CAA-Level UAV ID used for Remote Identification contains at least the following information:

- an identity unique to the UAV, which may preferably have temporary validity: this identifies uniquely the UAV with the entity that allocates the CAA-level UAV ID.

NOTE 1: Whether privacy or confidentiality requirements will apply to the unique UAV temporary identity depends on regulations in various regions.

- CAA-level UAV ID Routing Information, used by an entity attempting to retrieve the UAV data (e.g. TPAAE) to identify and address the appropriate UAS NF/NEF where to send the query. This is also used in USS discovery.

Two types of CAA-level UAV ID assignment are supported:

1. USS-assigned CAA-Level UAV ID: the identity is assigned completely at USS level.
2. 3GPP-assisted CAA-Level UAV ID assignment:
 - The allocation to the UAV of a CAA-Level UAV ID by the USS is done in collaboration with the UAS NF, for the use by the UAV for UUAA, and for the use for Remote Identification.
 - The USS interacts with the UAS NF to allocate the UAV identities to be used for Remote Identification (i.e. the CAA-Level UAV ID). When the UAV registers with the USS before registering to a 3GPP system for UAS services, the UAV operator provides information about the serving PLMN to the USS. In order to allocate a CAA-Level UAV ID, the USS interacts with a UAS NF if 3GPP Assisted CAA-Level UAV ID Assignment is desired. The 3GPP network selects a UAS NF to respond to the USS, and the UAS NF provides to the USS the CAA-Level Routing Information to enable a resolver of the CAA-level UAV ID to resolve to the UAS NF.
 - The USS delegates to the UAS NF the role of "resolver" of the CAA-Level UAV ID and return to an entity (e.g. the TPAAE) querying information about the UAV based on the CAA-Level UAV ID the UAV data that the UAS NF retrieves from the USS.

Editor's note: The details of mechanisms of exposure of UAS-NF to entities beyond USS outside the 3GPP system is FFS.

- It is assumed that the mapping between USS assigned CAA-level UAV ID and the associated 3GPP UAV ID is known by the UAS NF after the UAV is authorized by the USS via a successful UUAA. If UAS NF

receives a remote identification and tracking query from a TPAE with the USS-assigned CAA-Level UAV ID, the UAS NF uses the mapped 3GPP UAV ID to coordinate with different 3GPP functions to collect the UAV remote identification and tracking information. In addition, the UAS NF can retrieve aviation-level information (e.g. pilot information, USS operator, etc.) from the USS to provide it to the querying party (e.g. TPAE).

NOTE 2: It is assumed that the UAV is not aware of which assignment mechanisms is used for the CAA-Level UAV ID.

4.5 Identifiers

4.5.1 General

The UAV is associated with the following identifiers in the 3GPP system.

4.5.2 CAA-Level UAV Identity

A UAV is assigned a CAA-level UAV Identity by functions in the aviation domain (e.g. USS). This assigned identity is used for Remote Identification and Tracking and to identify the UAV.

The UAV provides the CAA-level UAV Identity to the 3GPP system during UUAA procedures.

The CAA-level UAV Identity is used by the UAV as UAV identity in Remote Identification.

The aviation domain may allocate a new CAA-level UAV Identity for the UAV at any time. The new CAA-level UAV Identity may be provided to the UAV and 3GPP system during UAS related procedures.

NOTE: It is assumed that mechanisms are available to ensure privacy and protection (e.g. anti-spoofing) of the CAA-assigned UAV Identity when it is used for Remote Identification. Security solutions to provide such privacy are outside the scope of this specification.

4.5.3 3GPP UAV ID

A 3GPP UAV ID is associated to the UAV by the 3GPP system in the subscription information and is used by the 3GPP system to identify the UAV. GPSI in the format of External Identifier is used as the 3GPP UAV ID.

The USS stores the association of the CAA-level UAV ID (provided by the UAV or a new one allocated by the aviation domain) to the 3GPP UAV ID (which is provided during the UUAA procedure).

5 Functional description and information flows

5.1 Control and user plane stacks

Editor's note: This clause will describe the protocol stacks on the control and user planes for each of the interfaces required for UAS.

5.2 UAV Authentication and Authorization

5.2.1 UUAA Model

The following applies for UUAA for a UAV:

- UUAA-MM is optional and performed at 5GS registration based on operator's policy. If required by the operator, UUAA-MM is performed if the UAV has an aerial UE subscription in the Access and Mobility Subscription Data and provides the CAA-Level UAV ID in the Registration Request message.
- UUAA-SM in 5GS is performed at PDU session establishment to a subscribed DNN applicable for UAS services if the UAV provides the CAA-Level UAV ID in the PDU Session Establishment Request message. Whether the DNN is applicable for UAS services is determined by the aerial service indication being set for the DNN in the Session Management Subscription Data.
- UUAA-SM in EPS is performed at PDN Connection Establishment when activating a PDN Connection to a subscribed APN applicable for UAS service if the UAV provides the CAA-Level UAV ID in the ESM container. Whether the APN is applicable for UAS services is determined by the aerial service indication being set for the corresponding DNN in the Session Management Subscription Data (fetched from UDM triggered by CAA-Level UAV ID being provided in request).
- UUAA-SM may be performed to re-authenticate the UAV or to reauthorize at PDU session modification or EPS bearer modification (e.g. in case of C2 authorization or flight plan authorization change) if the UE includes CAA-Level UAV ID and a UUAA Aviation Payload.

NOTE: If the network is configured to perform UUAA at registration, UAV has not provided CAA-Level UAV ID and the UE has aerial subscription, then the AMF can allow the UAV to register as a normal UE. If the network is configured to perform UUAA at PDU Session Establishment, the UE has not provided CAA-Level UAV ID and the SM subscription data indicates that UUAA-SM to be performed, the SMF rejects the PDU Session Establishment request.

5.2.2 UUAA at Registration in 5GS (UUAA-MM)

5.2.2.1 General

The UUAA-MM procedure is optional and triggered for a UE that requires UAV authentication and authorization by a USS when registering with 5GS. The UUAA-MM procedure is triggered by the AMF. UUAA-MM is triggered during the UE Registration based on the local network policy, if the UE has an Aerial UE subscription with the 5GS and if the UE has provided the CAA-Level UAV ID of the UAV in the Registration Request, or when the USS that authenticated the UAV triggers a re-authentication.

The UE is authenticated and authorized by USS using a CAA-Level UAV ID and credentials associated to the CAA-Level UAV ID, different from the 3GPP subscription credentials (e.g. SUPI and credentials used for PLMN access). During UUAA-MM procedure, the AMF communicates with the USS via a UAS NF and forwards authentication messages transparently between the UE and UAS NF.

UAS NF stores the UAV UEs UUAA context after successful UUAA procedure. The UUAA context may be stored in the UDSF or may be stored locally in the UAS NF depending on deployments. The UAS NF shall also create an implicit subscription for notification towards the AMF after the successful UUAA procedure. This notification is used by the UAS NF to trigger re-authentication, update authorization data or revoke authorization of the UAV, upon receipt of such request from the USS.

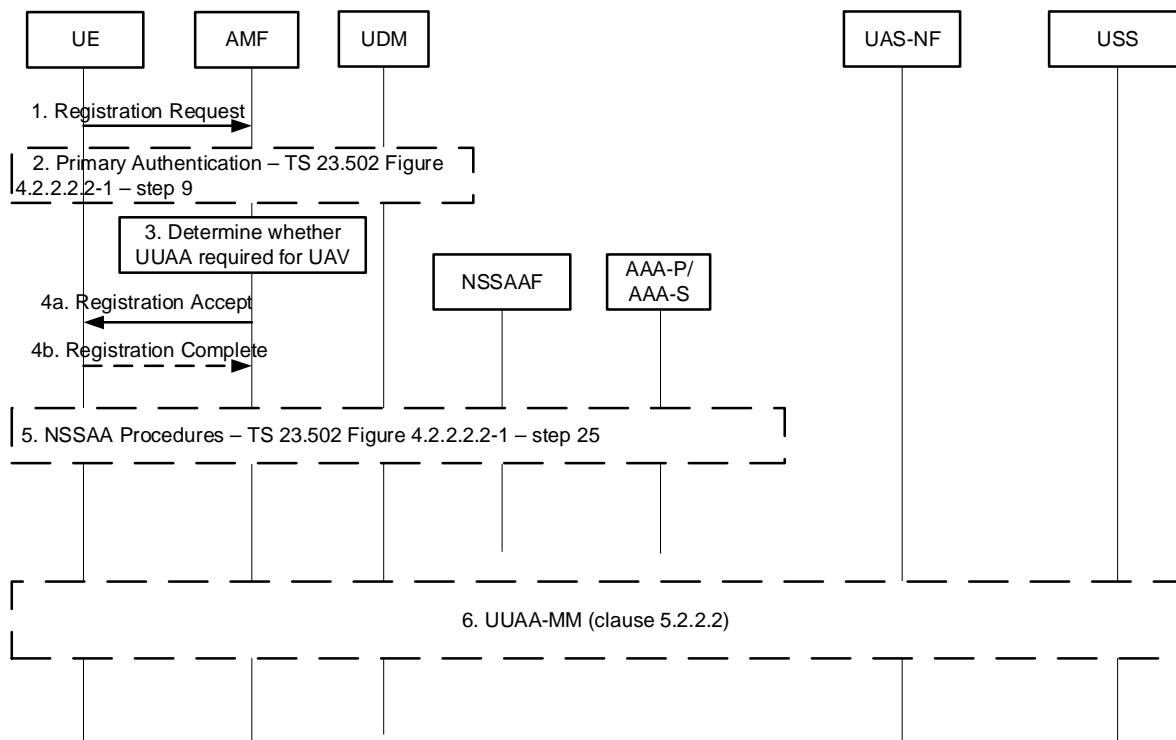

Figure 5.2.2.1-1: UUA in the context of the Registration procedure (UUA-MM)

1. The UE sends a Registration request message and, if configured with one, it shall provide a CAA-level UAV ID of the UAV and optionally a USS address when registering for UAS services.
2. If primary authentication is required (e.g. if this is an initial Registration), AMF invokes it as described in step 9 in Figure 4.2.2.2.2-1 of TS 23.502 [3]. Subsequently AMF retrieves UE subscription data from UDM as described in step 14 in Figure 4.2.2.2.2-1 of TS 23.502 [3] - (not shown in the figure).
3. AMF shall determine whether UUA-MM is required for the UAV. The AMF decides that UUA is required if:
 - a) the UE has a valid Aerial UE subscription information;
 - b) UUA is to be performed during Registration according to local operator policy;
 - c) there is no successful UUA result from a previous UUA-MM procedure;
 - d) the UE has provided a CAA-Level UAV ID.

AMF shall not perform UUA-MM for non-3GPP access and shall ensure that the UE is not allowed to access any aerial services in non-3GPP access by rejecting PDU session establishment requests for aerial services (identified by DNN/S-NSSAI).

4. If AMF determines in step 3 that a UUA-MM is to be performed, AMF shall include a pending UUA-MM indication in the Registration Accept message. The AMF stores in the UE context that a UUA is pending. The UE shall wait for completion of the UUA-MM procedure without attempting to register for UAS services or to establish user plane connectivity to USS or UAV-C.

If AMF determines that UUA is not to be performed during this Registration procedure, UUA may be triggered during PDU Session Establishment later on.

If UUA is configured in the AMF to be performed during 5GS registration and the UE has provided a CAA-Level UAV ID in the registration request in step 1, but the UE does not have an aerial subscription in the UE subscription data retrieved from the UDM in step 2, then the AMF rejects the registration with an indication informing no aerial subscription. This information indicates to the UAV of the reason for the rejection for aerial services and ensures that the UE is not allowed to access any aerial service.

If UAS services become enabled or disabled (e.g. because the aerial subscription becomes a part of the UE subscription data retrieved from UDM as described in clause 5.2.3.3.1 of TS 23.502 [3]) then AMF may trigger a

UE Configuration Update procedure as described in clauses 4.5.1 and 4.2.4.2 of TS 23.502 [3] to notify the UE. The UE may initiate a mobility registration update procedure to get the UAS services after completion of the UE Configuration Update procedure.

If UUAA is configured in the AMF to be performed during 5GS registration, the UE did not provide a CAA-Level UAV ID in the registration request in step 1, but UE has aerial subscription in the UE subscription data retrieved from UDM in step 2, then the AMF accepts the registration and ensures that the UE is not allowed to access any aerial service by storing in the UE context that 'UUAA-MM has FAILED', and further rejecting PDU session establishment requests for aerial services (identified by DNN/S-NSSAI). At a later point in time, if the UE wants to use the aerial services by providing the CAA Level UAV ID later on via UUAA-MM procedure, then the UE shall first perform Mobility Registration Update as explained in clause 4.2.2.2.2 of TS 23.502 [3].

5. If UE indicates its support for Network Slice-Specific Authentication and Authorization (NSSAA) procedure in the UE MM Core Network Capability, and if the UE includes Requested S-NSSAI in Registration Request which is subject to NSSAA, however, the Requested S-NSSAI has not been successfully authenticated, the NSSAA procedure is executed as described in clause 4.2.2.2.2 of TS 23.502 [3].
6. If required based on step 3 determination, and if the S-NSSAI that is associated with the UAS services is part of the Allowed NSSAI, UUAA-MM procedure (see clause 5.2.2.2) is executed at this step. Once the UUAA-MM procedure is successfully completed for the UAV, the AMF stores a successful UUAA result and updates the UE context indicating that UUAA is no longer pending and the authorized CAA-Level UAV ID if provided by the USS. The USS may provide a new CAA-Level UAV ID as the authorized CAA-Level UAV ID. The AMF shall trigger a UE Configuration Update procedure (see TS 23.502 [3], clause 4.2.4.2) to deliver the UUAA result, the UUAA Authorization Payload containing UAV configuration and the authorized CAA-Level UAV ID if received from the USS to the UE.

NOTE 1: The UAV configuration is application layer information outside the scope of 3GPP.

If UUAA fails, based on local network policy, the AMF may decide to de-register the UE with an appropriate cause value in the De-Registration Request message, or keep the UE-registered with a failure UUAA result in UE context as described in step 7 of clause 5.2.2.2 and ensures that the UE is not allowed to access any aerial service based on the DNN/S-NSSAI value. If the UE is de-registered, the UE may re-attempt to re-register without including the CAA-level UAV ID.

NOTE 2: The security aspects for this procedure is defined in TS 33.256 [10].

5.2.2.2 UUA-MM Procedure

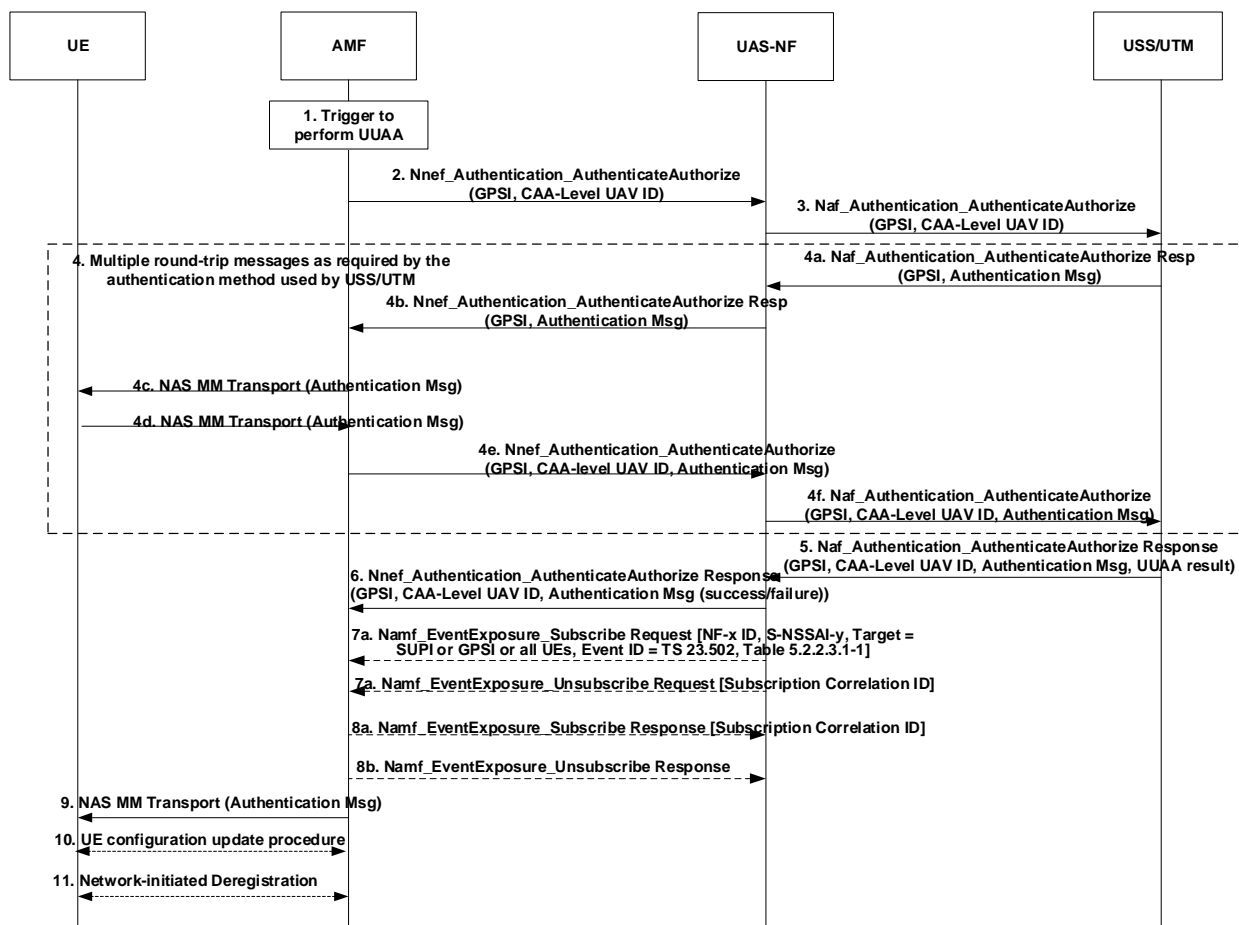

Figure 5.2.2.2-1: UUA-MM procedure

1. For a UE that requires UUA or when triggered by re-authentication by USS, the AMF triggers a UUA-MM procedure. If the UE does not have an Aerial subscription in the UE subscription data retrieved from the UDM, the AMF shall not trigger a UUA-MM procedure.
2. AMF to UAS NF/NEF: The AMF invokes Nnef_Authentication_AuthenticateAuthorize Request message. For initial authentication, this shall include the GPSI and the CAA-Level UAV ID and may include USS address (e.g. FQDN), UUA Aviation Payload if it was provided by the UE. For re-authentication triggered by AMF, this may not include the CAA-Level UAV ID. UAS NF resolves the USS address based on CAA-Level UAV ID or uses the provided USS address, as described in clause 4.4.2. In addition, the AMF may also include the User Location Information (e.g. Cell ID). The UAS NF should store the serving AMF ID.

The AMF identifies the UAS NF/NEF based on local configuration or by NF discovery procedure using DNN/S-NSSAI and/or UE provided identity e.g. USS address.

The AMF also provides a Notification Endpoint to the UAS NF/NEF, so that UAS NF/NEF can include this Notification Endpoint together with UUA updated parameters, as shown in clause 5.2.4. By providing the Notification Endpoint, the AMF is implicitly subscribed to be notified of re-authentication, update authorization data or revocation of UAV from UAS NF/NEF, if the UUA result is successful in step 5.

NOTE 1: The security aspects for this procedure is defined in TS 33.256 [10].

3. UAS NF/NEF to USS: Naf_Authentication_AuthenticateAuthorize Request message, shall include the GPSI and CAA-Level UAV ID and optionally UAV location obtained from AMF in step 2 e.g. to support geo-caging functionality. UAS NF/NEF may translate the Cell ID received as UAV location from AMF in step 2 into a corresponding geographic area and/or may further obtain the UE location information using Location Service Procedures as defined in TS 23.273 [8].

The UAS NF/NEF also provides a Notification Endpoint to the USS, so that USS can include this Notification Endpoint together with UUAA updated parameters, as shown in clause 5.2.4. By providing the Notification Endpoint, the UAS NF/NEF is implicitly subscribed to be notified of re-authentication, update authorization data or revocation of UAV from USS, if the UUAA result is successful in step 5.

4. [Conditional] Multiple round-trip messages as required by the authentication method used by USS. Naf_Authentication_AuthenticateAuthorize Response messages from USS shall include GPSI and shall include an authentication message based on authentication method used that is forwarded transparently to UE over NAS MM transport messages. The authentication message in step4d may contain UUAA Aviation Payload required by the USS if it was not provided by the UE before.
5. USS to UAS NF/NEF: (final) Naf_Authentication_AuthenticateAuthorize Response message, shall include: GPSI, a UUAA result (success/failure) for the UAV and the UAS NF, may include an authorized/new CAA-Level UAV ID for the UAV and a UUAA Authorization Payload to the UAV (e.g. security info to be used to secure communications with USS), and a final authentication message (e.g. indicating success or failure, and if the UUAA is for re-authentication, indicating whether the UAS service related network resource can be released in case of UUAA failure) based on authentication method used that is forwarded transparently to UE over NAS MM transport messages.
6. UAS NF/NEF to AMF: (final) Nnef_Authentication_AuthenticateAuthorize Response message, forwards information received from USS in step 5. If UUAA for re-authentication failed and UAS NF/NEF received indication that the UAS service related network resource can be released in step 5, the UAS NF/NEF includes an indication that the PDU sessions associated with the "DNN(s) subject to aerial services" can be released.
- 7a. [Conditional] UAS NF/NEF to AMF: If UUAA-MM succeeded and UAS NF/NEF has not subscribed to AMF for the Mobility Event Exposure before, UAS NF/NEF subscribes to AMF for the mobility event notification by sending Namf_EventExposure_Subscribe request with the mobility events as described in TS 23.502 [3], Table 5.2.2.3.1-1 with Event ID = Reachability Filter.
- 7b. [Conditional] UAS NF/NEF to AMF: If UUAA-MM failed and UAS NF/NEF has subscribed to AMF for the Mobility Event Exposure earlier, UAS NF/NEF unsubscribes to AMF for the mobility event notification by sending Namf_EventExposure_Unsubscribe request with Subscription Correlation ID.
- 8a. [Conditional] AMF to UAS NF/NEF: The AMF acknowledges the subscription request from 7a by sending Namf_EventExposure_Subscribe response with Subscription Correlation ID.
- 8b. [Conditional] AMF to UAS NF/NEF: The AMF acknowledges the un-subscription request from 7b by sending Namf_EventExposure_Unsubscribe response.
9. AMF to UE: (final) NAS MM transport message forwarding authentication message from USS including authentication/authorization result (success/failure).
10. [Conditional] if UUAA-MM succeeded, AMF triggers a UE Configuration Update procedure to deliver to the UAV authorization information from USS, as described in clause 5.2.2.1.
11. [Conditional] If UUAA-MM fails during a Re-authentication and Re-authorization and there are PDU session(s) established using UAS services, and the USS has indicated that the network resources can be released, AMF may trigger these PDU Sessions release. AMF identifies the relevant PDU session(s) for UAS services based on the DNN/S-NSSAI value of the PDU session.

NOTE 2: When the UUAA-MM fails during a Re-authentication, and the USS has not indicated that the network resources can be released, the USS can initiate UUAA revocation as described in clause 5.2.7.

[Conditional] if UUAA-MM fails, based on network policy the AMF may trigger Network-initiated Deregistration procedure described (as specified in clause 4.2.2.3.3 of TS 23.502 [3]) and it shall include in the explicit De-Registration Request the appropriate rejection cause value.

If there is an AMF relocation for the UAV, the new serving AMF shall notify the UAS NF about the new AMF ID and the related CAA-level UAV ID using the existing AMF event notification service.

At any time after the initial registration, the USS (via UAS NF/NEF) or the AMF may initiate Re-authentication procedure for the UAV. For AMF initiated case the Re-authentication procedure shall start from step 2. USS initiated re-authentication procedure is described in clause 5.2.4.

If the UE is deregistered as per clause 4.2.2.3 of TS 23.502 [3], then the AMF shall unsubscribe to UAS NF and then UAS NF/NEF may clear the UUAA-MM context and update USS.

5.2.3 UUAA At PDN Connection/PDU Session Establishment (UUAA-SM)

5.2.3.1 General

NOTE 1: The security aspects for this procedure is defined in TS 33.256 [10].

An UAV uses PDU Sessions or PDN Connections in the UE for connectivity with the USS and for connectivity with a networked UAV-C.

A networked UAV-C is a UE which uses existing procedures for establishing PDU Session or PDN Connection for communication with the USS/UTM, and the procedures described in this clause do not apply to a networked UAV-C.

This clause describes procedure that applies both for 5GS and EPS, where PDU Session refers to 5GS and PDN Connection refers to EPS.

PDU Session(s)/PDN Connection(s) for UAS services shall only be established after a UAV has been authenticated and authorized by the USS. This may happen during UUAA-SM as described in this clause.

A UAV may use either a common or separate PDU Session/PDN connection for connectivity with the USS and a UAV-C.

When the UAV requests establishment of a PDU session/PDN connection, the PDU session/PDN Connection may require UUAA authorization of the UAV, subject to operator policy and regulatory requirements.

If the UAV uses the PDU session/PDN connection for C2 the PDU session is subject to C2 authorization as described in clause 5.2.5.

The PDU Session/PDN Connection is identified by the SMF/SMF+PGW-C as being for USS/C2 communication based on the aerial service indication set in the Session Management Subscription data for the DNN or DNN and S-NSSAI combination.

To subscribe to the PDU Session/PDN Connection Status Event, UAS NF/NEF determines the APN/DNN or DNN and S-NSSAI combination as below:

- The UAS NF/NEF may receive APN/DNN or DNN and S-NSSAI combination from the USS as specified in clause 4.15.3.2.3 of TS 23.502 [3];
- The UAS NF/NEF may map the AF-Identifier from the USS into APN/DNN or DNN and S-NSSAI combination based on local configuration as specified in clause 4.15.3.2.3 of TS 23.502 [3]; or
- The UAS NF/NEF may map the External Application Identifier from the USS into the APN/DNN or DNN and S-NSSAI combination based on local configuration.

NOTE 2: If the PDU session/PDN connection for C2 communication and the PDU session/PDN connection for USS communication are separate, different AF-Identifiers or External Application Identifiers can be used.

During the establishment or modification procedure of the PDU Session/PDN connection for C2 communication, the USS shall provide the 3GPP system with following information for enabling basic C2 communication between UAV and UAV-C:

- Traffic filters;
- QoS requirements.

The USS can enable/disable C2 communication between UAV and UAV-C necessary for services used during the flight operation at any point in time as described in clause 5.2.9.

UAS NF stores the UAV UEs UUAA context after successful UUAA-SM procedure. The UUAA context may be stored in the UDSF or may be stored locally in the UAS NF depending on deployments. The SMF shall subscribe for notifications from UAS NF which may be used to trigger re-authentication, update authorization data or revoke authorization of the UAV, upon receipt of such request from the USS.

Clause 5.2.3.2 defines the USS UAV Authorization/Authentication (UUA) procedures at PDU Session Establishment in 5GS and clause 5.2.3.3 is for the PDN Connection Establishment in the Attach procedure for EPS using the interworking functionality.

When the C2 authorization is revoked by the USS, the SMF or SMF+PGW-C shall release the PDU Session/PDN connection for C2 communication (in case separate PDU Sessions/PDN Connections are used), or disable C2 communication for the PDU Session/PDN connection (in case common PDU Session/PDN Connection is used), e.g. by removing the traffic filters for C2 communications and the QoS flow for C2 communication, and informs the UE with a PDU session modification/bearer modification request.

When the UUA is revoked by the USS, all UAV related PDU Session/PDN connections shall be released.

5.2.3.2 USS UAV Authorization/Authentication (UUA) during the PDU Session Establishment

The USS UAV Authorization/Authentication (UUA) is triggered by the SMF during the PDU Session Establishment, specified in TS 23.502 [3], clause 4.3.2.2 and additionally based on the SM subscription data obtained from UDM, and the Service Level Device Identity provided by the UE in the PDU Session establishment request.

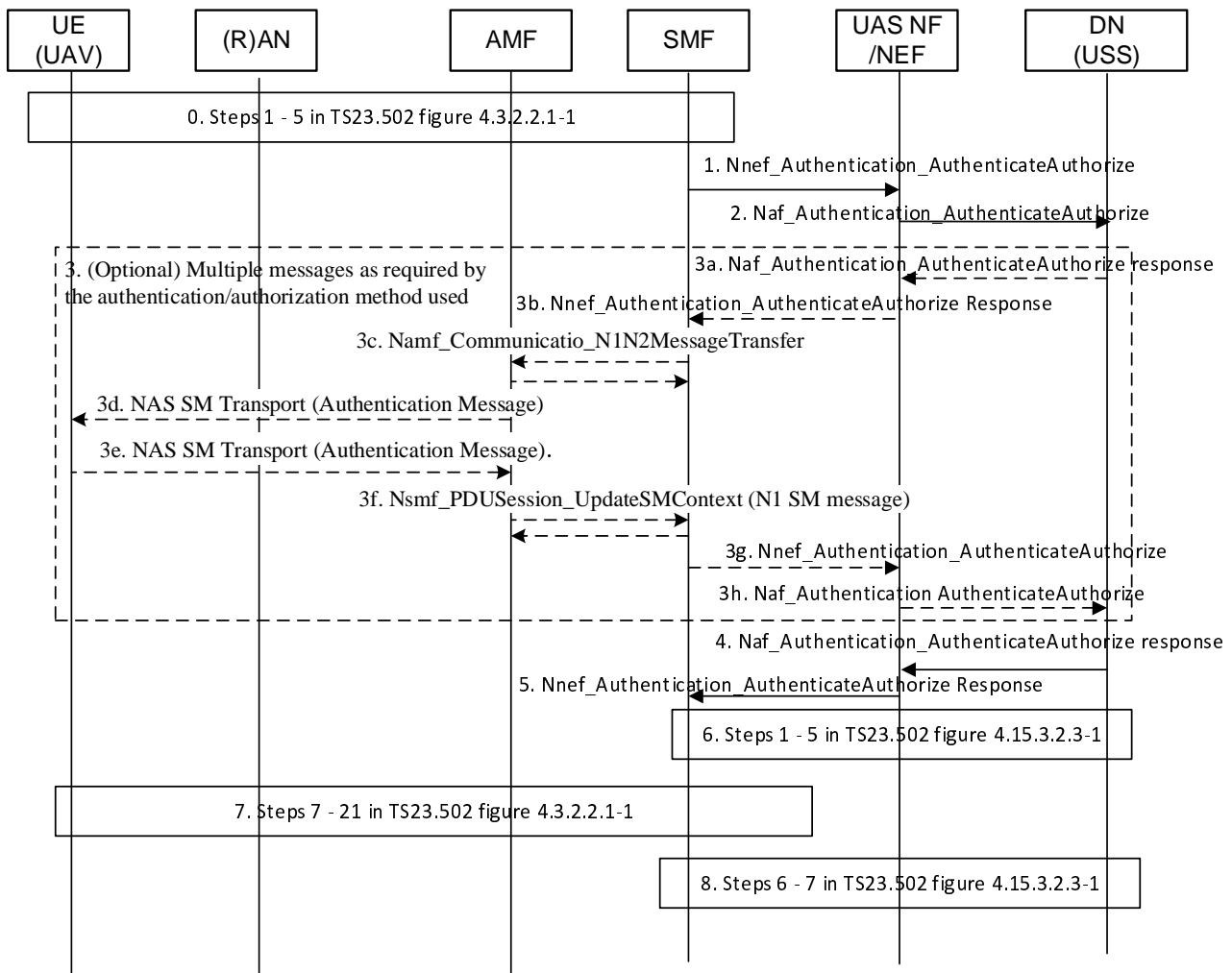

Figure 5.2.3.2 -1: UUA during PDU Session Establishment

The procedure assumes that the UE/UAV has already registered on the AMF.

- 0. Steps 1 - 5 as in TS 23.502 [3] figure 4.3.2.2.1-1.

The UAV includes the Service Level Device Identity (e.g. the CAA-Level UAV ID of the UVA) and may include the Authentication Server Address (i.e. the USS address) and optionally Authentication Data (i.e. the UUA Aviation Payload) in the PDU Session Establishment request.

The SMF determines that it needs to invoke UAS NF/NEF service operation for UUAA Authentication/Authorization of the PDU session establishment request based on that the provided DNN/S-NSSAI combination is dedicated for aerial services (have aerial service indicator set) and that the Service Level Device Identity (CAA-Level-UAV ID) is included in the request. If the provided APN/DNN is dedicated for aerial services but Service Level Device Identity (CAA-Level UAV ID) is not provided, the SMF shall reject the establishment of the PDU Session and steps 1 - 9 are not performed.

The SMF identifies the UAS NF/NEF based on local configuration or by NF discovery procedure using DNN/S-NSSAI and/or UE provided identity e.g. USS address.

1. The SMF invokes Nnef_Authentication_AuthenticateAuthorize service operation, including the Service Level Device Identity (that contains the CAA-Level UAV ID of the UAV), DNN, S-NSSAI, and may include the Authentication Server Address (i.e. the USS address) and the UUAA Aviation Payload if it was provided by the UE, GPSI, optionally UAV location, PEI if available, and the UE IP Address if available. The UAV location is the User Location Information provided by the AMF (e.g. Cell ID). The UAS NF/NEF selects a USS based on either the Service Level Device Identity (i.e. CAA-Level UAV ID of the UAV) or the Authentication Server address (i.e. USS address) as described in clause 4.4.2.

SMF also provides a Notification Endpoint to the UAS NF/NEF, so that UAS NF/NEF can include this Notification Endpoint together with UUAA updated parameters, as shown in clause 5.2.4. By providing the Notification Endpoint, the SMF is implicitly subscribed to be notified of re-authentication, update authorization data or revocation of UAV from UAS NF/NEF, if the UUAA result is successful in step 4.

2. From UAS NF/NEF to USS: Naf_Authentication_AuthenticateAuthorize service operation forwarding the authentication request received information from the SMF. UAS NF may translate the Cell ID received as part of UAV location in the Nnef_Authentication_AuthenticateAuthorize request at step 1 into a corresponding geographic area and/or may further obtain the UE location information using Location Service Procedures as defined in TS 23.273 [8] and include them in the Naf_Authentication_AuthenticateAuthorize message towards the USS e.g. to support geo-caging functionality.

UAS NF/NEF also provides a Notification Endpoint to the USS, so that USS can include this Notification Endpoint together with UUAA updated parameters, as shown in clause 5.2.4. By providing the Notification Endpoint, the UAS NF/NEF is implicitly subscribed to be notified of re-authentication, update authorization data or revocation of UAV from USS, if the UUAA result is successful in step 4.

3. [Conditional] Multiple round-trip messages as required by the authentication method used by USS. This step is performed if the Naf_Authentication_AuthenticateAuthorize response messages from USS in step 3a does not contain a UUAA result (SUCCESS/FAILURE). Naf_Authentication_AuthenticateAuthorize response messages from USS shall include GPSI and shall include an authentication message based on authentication method used that is forwarded transparently to UE over NAS MM transport messages. The authentication message in step 3e may contain UUAA Aviation Payload required by the USS if it was not provided by the UE before.
4. From USS to UAS NF/NEF: Naf_Authentication_AuthenticateAuthorize response.

The USS sends Naf_Authentication_AuthenticateAuthorize response to the UAS NF/NEF with the Authentication/Authorization result containing the UUAA result (SUCCESS/FAILURE) for the UAS NF and indication whether the UAS service related network resource can be released in the case of UUAA failure for re-authentication or re-authorization, optionally a Service Level Device Identity containing the authorized CAA-Level UAV ID, requested policy information and the UUAA Authorization Payload. The requested policy information from USS may contain a DN Authorization Profile Index and/or a DN authorized Session AMBR. The USS may include a new CAA-Level UAV ID as authorized CAA-Level UAV ID.

- NOTE 1: The USS stores a mapping between CAA-Level UAV ID and the External Identifier (i.e. GPSI as defined in clause 4.5.3). The External Identifier (GPSI) and/or UAV IP Address can be used at a later point by the USS for accessing various services exposed by 3GPP network e.g. location information retrieval, monitoring event configuration, requesting dedicated policies for e.g. C2, etc.
5. The UAS NF/NEF confirms the successful Authentication/Authorization of the PDU Session. The UAS NF/NEF stores the UUAA result together with the GPSI. UAS NF/NEF forwards the Authentication/Authorization result, a Service Level Device Identity containing the authorized CAA-Level UAV ID and the Authorization Data (i.e. the UUAA Authorization Payload), if received from the USS, to the SMF.
 6. [Conditional] If the authentication/authorization is successful, the USS shall subscribe to the PDU Session Status Event as described in steps 1-5 in Figure 4.15.3.2.3-1 of TS 23.502 [3]. This step can be executed in parallel to

step 4. The UAS NF/NEF determines the DNN, S-NSSAI to subscribe to the PDU Session Status Event notification as specified in clause 5.2.3.1.

7. The PDU Session establishment continues with steps 7 to 21 in Figure 4.3.2.2.1-1 of TS 23.502 [3] and completes. In the step 7b in Figure 4.3.2.2.1-1 of TS 23.502 [3], if the SMF receives the DN Authorization Profile Index from the UAS NF/NEF, it sends the DN Authorization Profile Index to retrieve the PDU Session related policy information (described in clause 6.4 of TS 23.503 [9]) and the PCC rule(s) (described in clause 6.3 of TS 23.503 [9]) from the PCF. If the SMF receives the DN authorized Session AMBR in from the UAS NF/NEF, it sends the DN authorized Session AMBR within the Session AMBR to the PCF to retrieve the authorized Session AMBR (described in clause 6.4 of TS 23.503 [9]).

The SMF transfers the Authentication/Authorization result, the Service Level Device Identity containing the authorized CAA-Level UAV ID and the Authorization Data (i.e. the UUAA Authorization Payload) to the UAV if received from the UAS NF, as in steps 11, 12 and 13 in figure 4.3.2.2.1-1 of TS 23.502 [3].

If the authentication/ authorization result is a failure, the SMF rejects the PDU session establishment with a proper cause value.

8. [Conditional] If the USS in step 6 subscribed to the PDU Session Status Event the SMF will, as described in steps 6-7 in Figure 4.15.3.2.3-1 of TS 23.502 [3], detect when the PDU Session is established, and send the PDU Session Establishment event report to the UAS NF/NEF by means of Nsmf_EventExposure_Notify message, including GPSI and the UE IP Address. Then, the UAS-NF/NEF forwards the event message to the USS.

If UUAA-SM fails during a Re-authentication and Re-authorization and the USS has indicated that the network resources can be released, SMF may trigger PDU Session release for UAS services with a proper cause value.

NOTE 2: When the UUAA-SM fails during a Re-authentication, and the USS has not indicated that the network resources can be released, the USS can initiate UUAA revocation as described in clause 5.2.7.

NOTE 3: If C2 information reference is available from USS during the initial PDU Session Establishment procedure the SMF can interact with the PCF to set up a predefined PCC rule(s) profile for the C2 communication.

If the PDU session is released as per clause 4.3.4 of TS 23.502 [3] then the SMF shall unsubscribe to UAS NF/NEF and then UAS NF/NEF may clear the UUAA-SM context and update USS.

5.2.3.3 USS UAV Authorization/Authentication (UUAA) during default PDN connection at Attach

In the figure 5.2.3.3-1 the execution of the UUAA is specified.

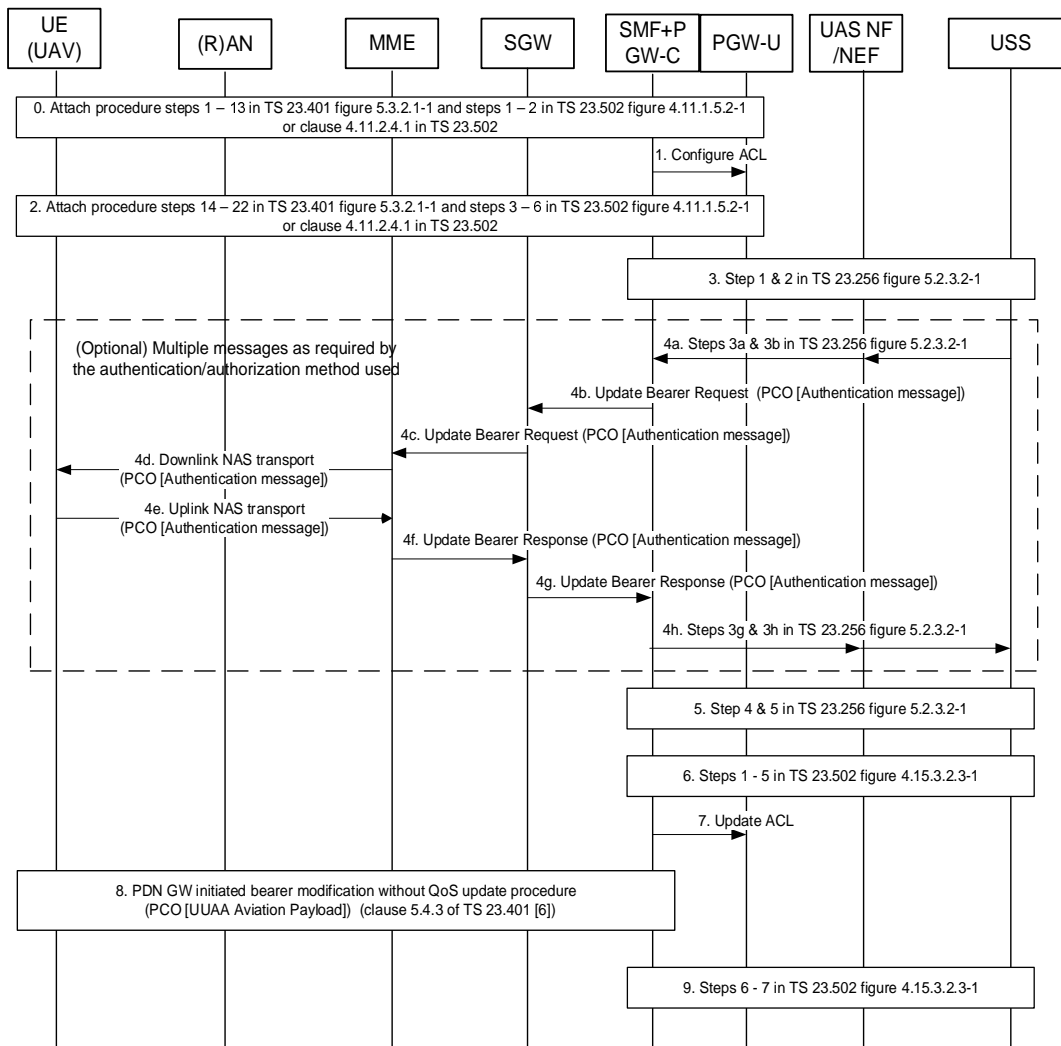

Figure 5.2.3.3-1: UUA during PDN connection establishment at Attach procedure in EPS

- 0. Steps 1 - 13 in TS 23.401 [6] figure 5.3.2.1-1 and steps 1 - 2 in TS 23.502 [3] figure 4.11.1.5.2-1 or clause 4.11.2.4.1 in TS 23.502 [3].

UE sends Attach Request including the Service Level Device Identity (i.e. the CAA-Level UAV ID of the UAV), and may include the Authentication Server Address (i.e. the USS address) and optionally Authentication Data (i.e. the UUA Aviation Payload), etc. in the PCO to the SMF+PGW-C.

Based on that the Service Level Device Identity (CAA-Level UAV ID) is provided with the request, the SMF+PGW-C retrieves the Session Management Subscription Data from the UDM+HSS using the Nudm_SDM_Get service operation, and based on that the provided APN/DNN is dedicated for aerial services (have aerial service indicator set), it determines to invoke UAS NF/NEF service operation for UUA Authentication/Authorization. If the provided APN/DNN is dedicated for aerial services but Service Level Device Identity (CAA-Level UAV ID) is not provided, the SMF+PGW-C shall reject the establishment of the PDU Session and steps 1 -9 are not performed.

NOTE 1: The definition of the PCO field is for stage 3 to specify.

- 1. SMF+PGW-C configures an Access Control List (ACL) in UPF+PGW-U to stop any traffic over the default PDN Connection until the UUA has been done and successful.
- 2. Steps 14 - 22 in figure 5.3.2.1-1 of TS 23.401 [6] and steps 3 - 6 in figure 4.11.1.5.2-1 of TS 23.502 [3] or clause 4.11.2.4.1 of TS 23.502 [3].

During the Attach procedure, at step 15 of Figure 5.3.2.1-1 in TS 23.401, the SMF+PGW-C includes, in PCO, an Indication to the UE that "UpLink Data NOT ALLOWED" on the PDN connection. The UE shall not send Uplink data to the network, until it receives an indication further from the network that "UpLink Data ALLOWED".

3. UUA is invoked as described in steps 1 and 2 of figure 5.2.3.2-1.
4. [Conditional] Multiple round-trip messages as required by the authentication method used by USS. This step is performed if the Naf_Authentication_AuthenticateAuthorize response messages from USS in step 4a does not contain a SUCCESS/FAILURE indication. The PCO including the authentication message from the USS is transferred to the UE by the SMF+PGW-C in Update Bearer Request and Downlink NAS Transport (steps 4b - 4d). The response from the UE is transferred to the SMF+PGW-C in an Uplink NAS Transport and Update Bearer Response (steps 4e - 4g).
5. UUA procedure continues as described in steps 4 & 5 of figure 5.2.3.2-1.
6. If the authentication/authorization is successful, the USS shall subscribe to the PDN Connection Status Event as described in steps 1-5 in figure 4.15.3.2.3-1 of TS 23.502 [3]. This step can be executed in parallel to step 5. The UAS NF/NEF determines the APN/DNN to subscribe to the PDN Connection Status Event notification as specified in clause 5.2.3.1.
7. If the UUA is successful, the SMF+PGW-C contacts the PCF to update the PDN Connection. Then the SMF+PGW-C updates the Access Control List (ACL) and policies in the UPF+PGW-U to allow traffic over the default PDN Connection. If a DN Authorization Profile Index was received from the UAS NF/NEF SMF+PGW-C in previous step, the SMF+PGW C includes that when retrieving the ACL from the PCF. If the SMF receives the DN authorized Session AMBR in from the UAS NF/NEF, it sends the DN authorized Session AMBR within the Session AMBR to the PCF to retrieve the authorized Session AMBR (described in clause 6.4 of TS 23.503 [9]).
8. The SMF+PGW-C updates the UE by invoking the PDN GW initiated bearer modification without QoS update procedure (figure 5.4.3-1 of TS 23.401 [6]) initiated by sending an Update Bearer Request message to the SGW. The PCO includes an indication that "UpLink Data ALLOWED", the UUA Aviation Payload i.e. the Authentication/Authorization result and the Authorization Data. The UE (for the UAV) confirms the update (see clause 5.4.3 of TS 23.401 [6]).
9. If the USS in step 6 subscribed to the PDN Connection Status Event the SMF+PGW-C will, as described in steps 6-7 in Figure 4.15.3.2.3-1 of TS 23.502 [3], detect when the PDN Connection is established and send the PDN Connection Establishment event report to the UAS NF/NEF by means of Nsmf_EventExposure_Notify message, including GPSI and the UE IP Address. Then, the UAS NF/NEF forwards the event message to the USS.

5.2.4 UUA Re-authentication and Re-authorization by USS/UTM

5.2.4.1 UAV Re-authentication procedure in 5GS

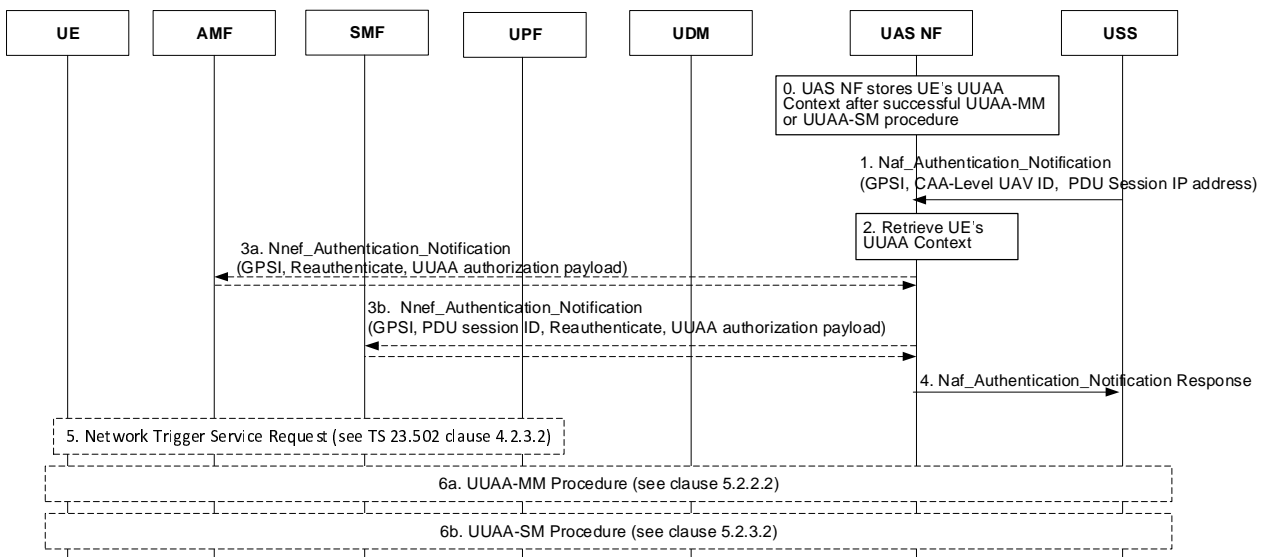

Figure 5.2.4.1-1: UAV Re-authentication procedure in 5GS

UAS NF stores the UE UUA context after successful UUA procedure as explained in clause 5.2.2.2 for UUA-MM and in clause 5.2.3 for UUA-SM procedure. The UUA context may be stored in the UDSF or may be stored locally in the UAS NF depending on deployments.

1. The USS sends a Naf_Authentication_Notification request to UAS NF for re-authentication of the UAV. The USS includes GPSI, CAA-Level UAV ID, PDU Session IP address if available in the re-authentication request and an authentication message to be transparently delivered to the UAV.
2. UAS NF retrieves the stored UUA context for the UE. From the stored UUA context the UAS NF determines the target AMF or SMF for sending the notification.
- 3a or 3b. The UAS NF sends Nnef_Authentication_Notification request to notify the target NF, i.e. either the AMF or the SMF, to initiate re-authentication of the UAV.
4. The UAS NF responds back to the USS indicating that re-authentication request has been successfully initiated
5. If UE is in CM_Idle state, the target NF (i.e. either the AMF or the SMF) initiates the Network Triggered Service Request procedures as described in clause 4.2.3.3 of TS 23.502 [3].
- 6a. If UUA-MM was performed, the AMF initiates re-authentication of the UAV as described in steps 4c to 10 of UUA-MM procedure, clause 5.2.2.2.
- 6b. If UUA-SM was performed, the SMF then initiates re-authentication of the UAV as described in steps 3c to 7 of the UUA-SM procedure, clause 5.2.3.2.

5.2.4.2 UAV Re-authentication procedure in EPS

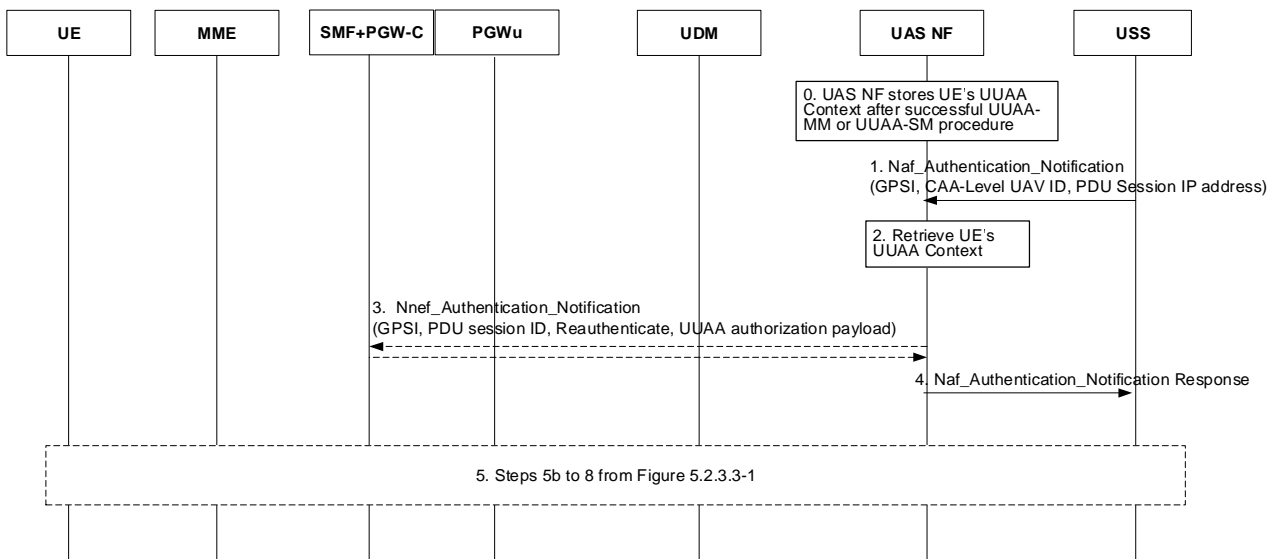

Figure 5.2.4.2-1: UAV Re-authentication procedure in EPS

UAS NF stores the UE UUAA context after successful UUAA-SM procedure as explained in clause 5.2.3. The UUAA context may be stored in the UDSF or may be stored locally in the UAS NF depending on deployments.

1. The USS sends a Naf_Authentication_Notification request to UAS NF for re-authentication of the UAV. The USS includes GPSI, CAA-Level UAV ID, UE IP address in the re-authentication request and an authentication message to be transparently delivered to the UAV.
2. UAS NF retrieves the UE stored UUAA context. From the stored UUAA context the UAS NF determines the target SMF+PGW-C for sending the notification.
3. The UAS NF sends Nnef_Authentication_Notification request to notify the SMF+PGW-C, to initiate re-authentication of the UAV.
4. The UAS NF responds back to the USS indicating that re-authentication request has been successfully initiated
5. The SMF+PGW-C then initiates re-authentication of the UAV as in steps 5b to 8 in Figure 5.2.3.3-1: UUAA during PDN connection establishment at Attach procedure in EPS.

5.2.4.3 USS initiated UAV Re-authorization procedure in 5GS

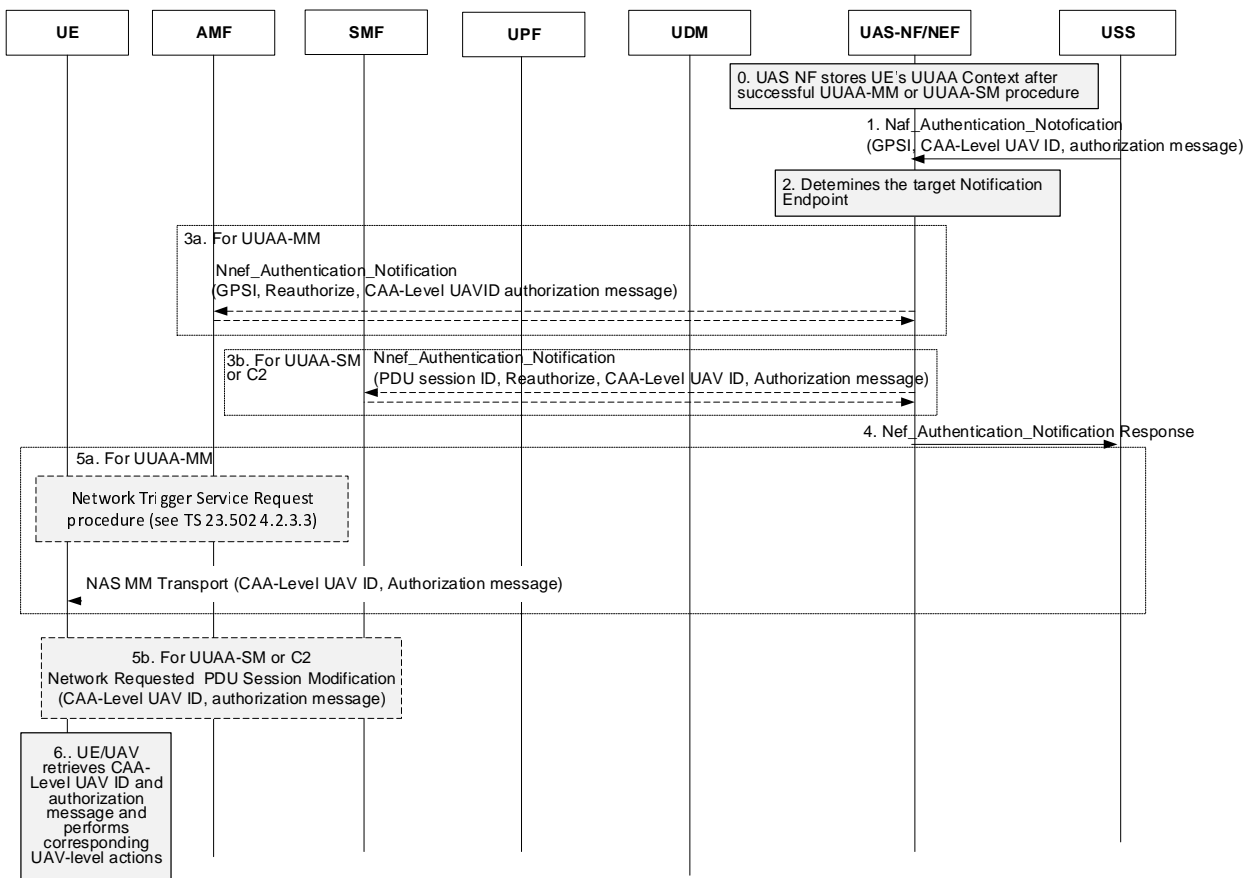

Figure 5.2.4.3-1: UAV Re-authorization procedure in 5GS

UAS NF stores the UE UAAA context after successful UAAA procedure as explained in clause 5.2.2.2 for UAAA-MM and in clause 5.2.3 for UAAA-SM procedure. The UAAA context may be stored in the UDSF or may be stored locally in the UAS NF depending on deployments.

1. The USS sends a Naf_Authentication_Notification request to UAS NF for re-authorization of the UAV. The USS includes GPSI, CAA-Level UAV ID, Notification Correlation Information, an authorization message to be transparently delivered to the UAV. The CAA-Level UAV ID may be a new CAA-Level UAV ID. The authorization message may e.g. include a UAAA Authorization Payload, a C2 Authorization Result and a C2 Authorization Payload (e.g. containing C2 pairing information and C2 security information).
2. Based on the received GPSI and Notification Correlation Information from the USS, the UAS NF/NEF determines the corresponding Notification Correlation Information for Nnef_Authentication_Notification request.
- 3a For UAAA-MM re-authorization, the UAS-NF/NEF sends a Nnef_Authentication_Notification request including the CAA-Level UAV ID and the authorization message to the serving AMF.
- 3b For UAAA-SM re-authorization or C2 re-authorization, the UAS-NF/NEF sends a Nnef_Authentication_Notification request to the SMF serving the UAAA or C2 for the UE which includes the corresponding PDU session identity, CAA-Level UAV ID and the authorization message.
4. The UAS NF responds back to the USS indicating that re-authorization request has been successfully initiated.
- 5a. In the case of UAAA-MM:

If the UE is in CM_Idle state, the AMF initiates the Network Triggered Service Request procedures as described in clause 4.2.3.3 of TS 23.502 [3].

The AMF delivers the CAA-Level UAV ID and the authorization message to the UE using NAS MM Transport.

5b In the case of UUAA-SM or C2 re-authorization:

The SMF identifies, based on the received information, the PDU Session that is serving the UUAA-SM or C2 re-authorization and invokes the Network Requested PDU Session Modification procedure (figure 4.3.3.2-1 of TS 23.502 [3] triggering event SMF Requested modification) by sending Namf_Communication_N1N2MessageTransfer, including the CAA-Level UAV ID and the authorization message in the N1_SM_Container (step 3b in figure 4.3.3.2-1 of TS 23.502 [3]).

The Network Triggered service request procedure is invoked by AMF to forward the CAA-Level UAV ID and the authorization message included in the N1_SM_container to the UE (from step 3a in figure 4.2.3.3-1 of TS 23.502 [3]).

6. The UE receives the CAA-Level UAV ID and the authorization message, which may e.g. include a UUAA Authorization Payload, a C2 Authorization Result and a C2 Authorization Payload (e.g. containing C2 pairing information and C2 security information). The UE acts on it accordingly (outside the scope of 3GPP).

NOTE: The UAV-C replacement procedure is described in clause 5.2.8. The C2 connectivity revocation procedure is described in clause 5.2.9.

5.2.4.4 USS initiated UAV Re-authorization procedure in EPS

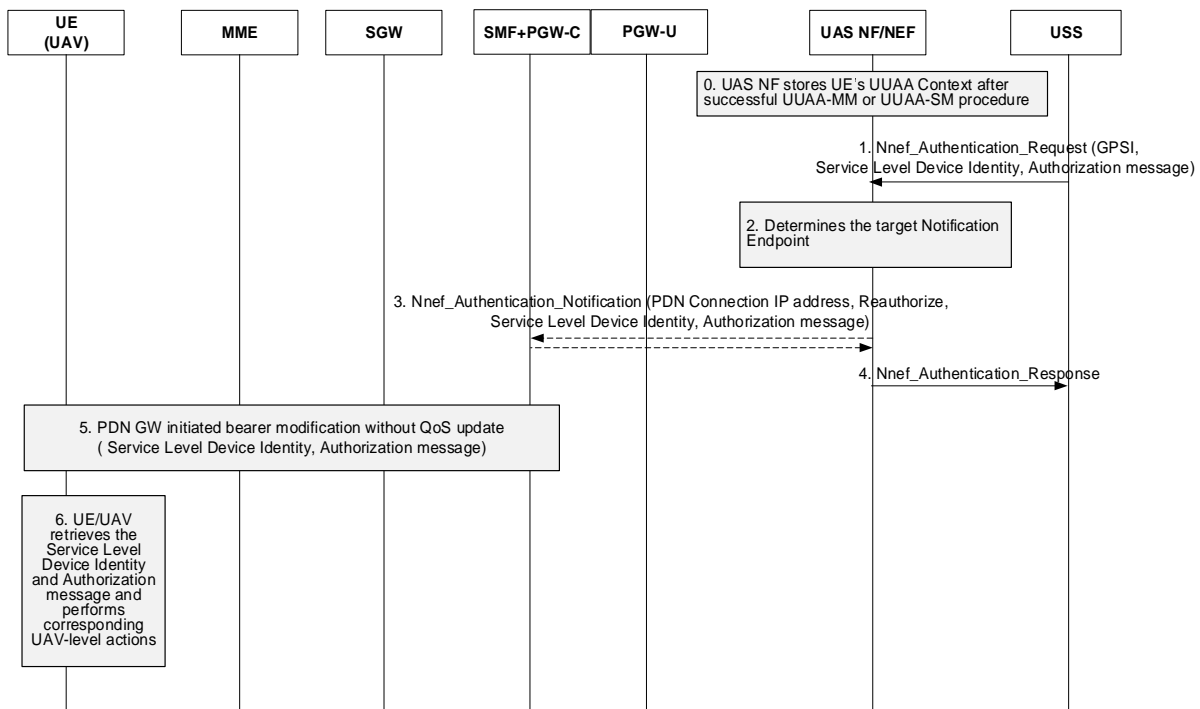

Figure 5.2.4.4-1: UAV Re-authorization procedure in EPS

UAS NF/NEF stores the UE UUAA context after successful UUAA procedure as in clause 5.2.3 for UUAA-SM procedure. The UUAA context may be stored in the UDSF or may be stored locally in the UAS NF/NEF depending on deployments.

1. The USS sends a request to UAS NF/NEF for re-authorization of the UAV. The USS includes GPSI, Service Level Device Identity (e.g. CAA-Level UAV ID), Notification Correlation Information and authorization message to be transparently delivered to the UAV. The Service Level Device Identity (e.g. CAA-Level UAV ID) may be a new Service Level Device Identity (e.g. CAA-Level UAV ID). The authorization message may e.g. include a UUAA Authorization Payload, a C2 authorization result and a C2 Authorization Payload (e.g. containing, C2 pairing information and C2 security information).
2. Based on the received GPSI and Notification Correlation Information from the USS, the UAS NF/NEF determines the corresponding Notification Correlation Information for Nnef_Authentication_Notification request.

NOTE 1: In EPS the UUA context is always UUA-SM.

3. The UAS NF/NEF sends a Nnef_Authentication_Notification request to the SMF+PGW-C serving the UUA or C2 which includes the corresponding PDN Connection identity, Service Level Device Identity (e.g. CAA-Level UAV ID) and the authorization message.
4. The UAS NF/NEF responds back to the USS indicating that re-authorization request has been successfully initiated.
5. The SMF+PGW-C identifies, based on the received information, the PDN Connection that is serving the UUA-SM and invokes the PDN GW initiated bearer modification without QoS update procedure (figure 5.4.3-1 of TS 23.401 [6]) by sending Update Bearer Request message, including the Service Level Device Identity (e.g. CAA-Level UAV ID) and the authorization message in the PCO.

The Update Bearer Request message including the Service Level Device Identity (e.g. CAA-Level UAV ID) and the authorization message is forwarded by MME as Downlink NAS Transport to the UE (steps 4 and 5 in figure 5.4.3-1 of TS 23.401 [6]).

6. The UE receives the Service Level Device Identity (e.g. CAA-Level UAV ID) and the authorization message (which may e.g. include a UUA Authorization Payload, a C2 authorization result and a C2 Authorization Payload (e.g. containing C2 pairing information and C2 security information)). The UE acts on it accordingly (outside scope of 3GPP).

NOTE 2: The UAV-C replacement procedure is described in clause 5.2.8. The C2 connectivity revocation procedure is described in clause 5.2.9.

5.2.5 Authorization for C2 over Uu

5.2.5.1 General

Authorization for C2 is required when a UAV establishes a user plane connection for C2 operations, i.e. to deliver messages with information of command and control for UAV operations from a UAV-C or USS to a UAV or to report telemetry data from a UAV to its UAV-C. Two sides of C2 communication, i.e. UAV and UAV-C, belong to the same UAS.

A UAV shall be authorized by the USS to use a PDU Session/PDN connection for C2. Authorization for C2 includes the following:

- UAV to UAV-C pairing authorization: Authorization for pairing with a networked UAV-C or a UAV-C that connects to the UAV via Internet connectivity, before the UAV and the UAV-C can exchange C2 communication. One UAV can be paired with only one UAV-C at the any time. One UAV-C may be paired with one or more UAVs at the same time.
- Flight Authorization: Authorization for flight when UAV also provides Flight Authorization information.

C2 authorization may be carried out:

- During the UUA procedure (if UUA is carried out at PDU session/PDN connection establishment) as described in clause 5.2.3 when the UAV requests establishment of PDU Session/PDN connection for connectivity.
- During PDU Session Modification/ UE requested bearer resource modification when the UAV requires to use an existing PDU session/PDN connection to exchange C2 communication related messages.
- During a new PDU Session/PDN connection establishment, if the UAV requires to use a separate PDU Session/PDN connection for C2 communication.

5.2.5.2 Procedure for C2 authorization in 5GS

5.2.5.2.1 C2 Authorization request during UUA-SM procedure in 5GS

If C2 authorization is requested during the UUA-SM procedure the procedure described in clause 5.2.3.2 takes place with the following additions:

- In Step 0, the UE includes pairing information (if available) in a C2 Aviation Payload. which is forwarded further to the USS;
 - In step 4, the USS performs C2 authorization taking into account the included pairing information, the Service Level Device Identity/CAA-Level UAV ID and 3GPP UAV ID/GPSI. The USS includes the resulting C2 Authorization result and optionally a C2 authorization payload in the Naf_Authentication_AuthenticateAuthorize response returned to the UAS-NF/NEF and the UAS NF/NEF forwards to the UAV/UE in step 7.
 - The USS shall:
 - in step 4 include a DN Authorization profile Index specifying a predefined set of PCC-rules in the PCF with initial restriction on the type of traffic allowed to pass on the PDU-session. For example, only traffic exchanged with the USS might be allowed to pass.
- Once the authentication is complete, after step 4, the USS subscribes to PDU Session Status Events for the PDU session used for C2 communication, applicable for the GPSI received in step 2.
- when the USS in step 8 receives a PDU Session State Event Report indicating session start and including the PDU Session IP address the USS invokes the USS initiated pairing policy configuration procedure (see figure 5.2.5.4.1-1) with the received PDU Session IP address and authorized paired UAV-C IP-address as input to request corresponding traffic to be allowed on the PDU session in the UPF.

5.2.5.2.2 UE initiated PDU Session Modification for C2 Communication

C2 authorization is requested at PDU session Modification:

- After UAAA-SM is performed and a common PDU session is used for connectivity to USS and C2 communication to a UAV-C (as configured in the UAV); or
- If the UE has already established a PDU session for C2 communication to a UAV-C.

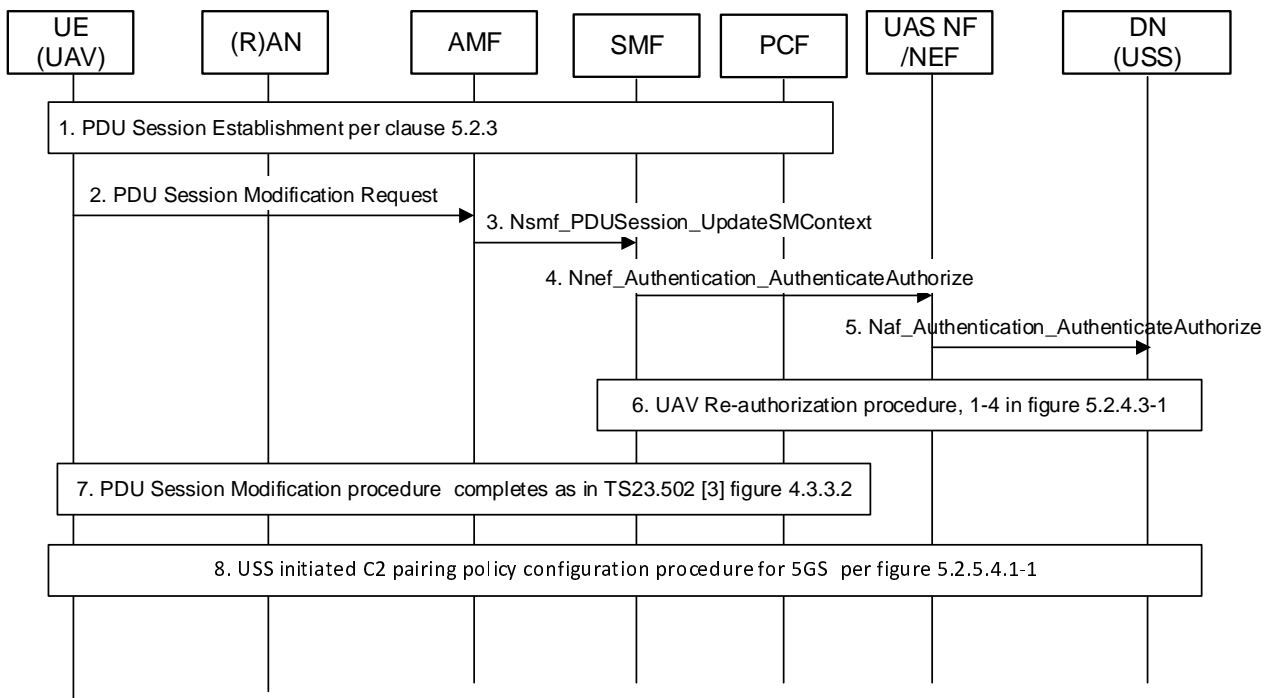

Figure 5.2.5.2.2-1: PDU Session modification for C2 communication (common PDU session for UAS services)

1. The UE establishes a PDU Session for USS communication as described in clause 5.2.3.
- 2-3. When the UAV needs to establish C2 communication the UAV determines that an existing PDU session can be used and initiates a PDU Session Modification procedure. The UE shall include in the request a CAA-Level UAV ID and shall include a C2 Aviation Payload within a UAS container that includes C2 authorization

information. The USS may also use its locally configured pairing information for UAV - UAV-C pairing authorization which takes precedence over UAV provided pairing information. The pairing information includes the CAA-level UAV ID of the requesting UE and also includes identification information of UAV-C to pair if available. The UAV may also include other information such as Flight Authorization information.

NOTE: How the pairing information is configured in the UAV is outside the scope of 3GPP specifications.

4. The SMF determines that authorization is required based on that the DNN/S-NSSAI of the PDU session is dedicated for aerial services (have aerial service indicator set) and that the Service Level Device Identity (CAA-Level UAV ID) is included in the request and Then sends a Nnef_Authentication_AuthenticateAuthorize request to the UAS-NF including the UAS container provided by the UAV in step 2 (including the C2 Aviation Payload), the CAA-Level UAV ID, GPSI, PDU Session IP address, and optionally the UAV location (e.g. Cell ID) provided by the AMF.
5. The UAS-NF forwards the received authorization request as a Naf_Authentication_AuthenticateAuthorize request to the USS.
6. Triggered by step 5, the USS performs C2 authorization based on the received information and invokes, in order to forward the C2 authorization result to the UAV/UE, the UAV Re-authorization procedure (see figure 5.2.4.3-1) including GPSI, CAA-Level UAV-ID (potentially new) and included in the authorization message, the C2 Authorization Result and the C2 Authorization Payload (e.g. containing C2 pairing information and C2 security information).
7. PDU Session Modification procedure forwards the C2 authorization result to the UAV/UE and completes as in figure 4.3.3.2-1 of TS 23.502 [3].
8. The USS invokes, with the received PDU Session IP address and the IP address of the authorized paired UAV-C as input, the USS initiated pairing policy configuration procedure (see figure 5.2.5.2.4-1) to request corresponding traffic to be allowed on the PDU session in the UPF.

Unless a dedicated QoS is requested for the C2 flows, this procedure does not invoke any interaction with the UE, AMF or RAN.

5.2.5.2.3 UE initiated PDU Session Establishment for C2 Communication

If C2 authorization is requested during PDU session establishment to a PDU session used specifically for C2 communication to UAV-C the UAV requests C2 authorization as follows.

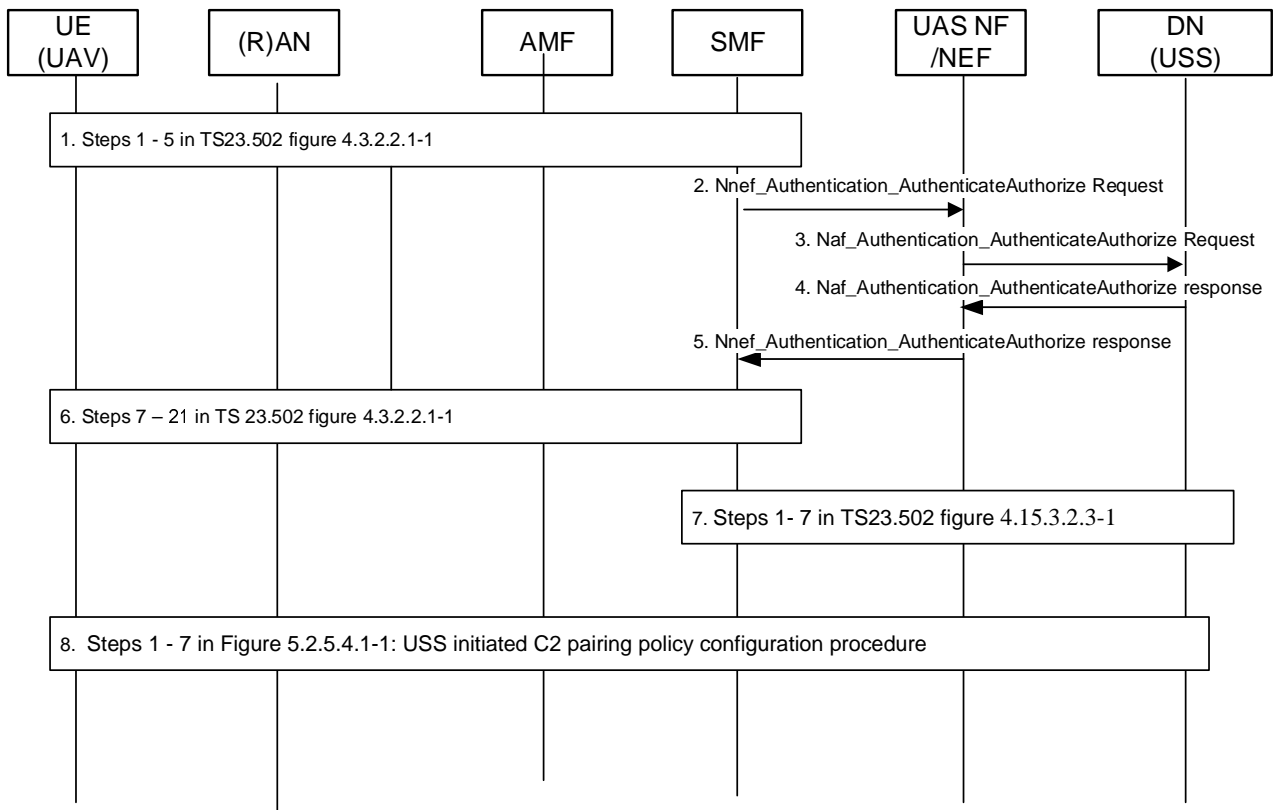

Figure 5.2.5.2.3-1: PDU Session establishment for C2 communication (separate PDU Sessions for UAS services)

0. The UAV has performed a successful UAAA with the USS (UAAA-SM or UAAA-MM) and the USS has for the corresponding GPSI subscribed for PDU Session Status Event from the NEF.
1. When the UAV needs to establish C2 communication the UAV determines that a new dedicated PDU session is required for connectivity to UAV-C. The UE initiates PDU Session establishment procedure for a DNN/S-NSSAI dedicated for connectivity to UAV-C. In the PDU Session establishment request CAA-Level UAV ID and a C2 Aviation Payload to be used for C2 authorization shall be included and forwarded to the SMF. The pairing information includes the CAA-Level UAV IDs of the requesting UAV and identification information for the UAV-C to pair may be included in C2 Aviation Payload. The UAV may also include other information such as Flight Authorization information. The USS may also use its locally configured pairing information for UAV - UAV-C pairing authorization which then takes precedence over UAV provided pairing information.
2. The SMF determines that authorization is required based on that the requested DNN/S-NSSAI combination dedicated for aerial services (have aerial service indicator set), and that the Service Level Device Identity (CAA-Level UAV ID) is included in the request. The SMF then sends a Nnef_Authentication_AuthenticateAuthorize request, which is used to request authorization to pair the UAV with UAV-C, to the UAS NF/NEF that includes the GPSI, CAA-Level UAV ID and C2 Aviation Payload and optionally the UAV location (e.g. Cell ID) if provided by the AMF and the DNN and S-NSSAI of the PDU session.

If the requested DNN/S-NSSAI is dedicated for aerial services but no Service Level Device ID (CAA-Level UAV ID) has been provided with the request, the SMF rejects the PDU session establishment with a cause indicating that USS authorization is required.

The SMF also provides a Notification Endpoint to the UAS NF/NEF. By providing the Notification Endpoint, the SMF is implicitly subscribed to be notified of re-authorization, update authorization data or revocation of C2 connectivity from UAS NF/NEF, if the C2 authorization result is successful in step 5.
3. The UAS NF/NEF checks that a valid UAAA is stored for the GPSI and forwards the received authorization request as a Naf_Authentication_AuthenticateAuthorize request to the USS. If not, the request is not forwarded to the USS and the PDU session is rejected.

The UAS NF/NEF also provides a Notification Endpoint to the USS. By providing the Notification Endpoint, the UAS NF/NEF is implicitly subscribed to be notified of re-authorization, update authorization data or revocation of C2 connectivity from USS, if the UUAA result is successful in step 5.

NOTE: The USS may trigger a UAV re-authentication/re-authorization in response to the query from the UAS NF/NEF.

4. The USS performs C2 authorization based on the received information and sends the Naf_Authentication_AuthenticateAuthorize response to the UAS NF/NEF including the Service Level Device Identity (e.g. the CAA-Level UAV-ID) (potentially new), the C2 Authorization Result and the C2 Authorization Payload (e.g. C2 pairing information and C2 security information).
5. The UAS-NF/NEF forwards the information received from the USS in the Nnef_Authentication_AuthenticateAuthorize response sent to the SMF.
6. To inform the UE about the C2 Authorization Result the SMF includes the authorization result and, optionally, a new CAA-Level UAV ID if received from the USS, in the PDU Session Accept sent to the UE and let the PDU session establishment procedure continue until finalized.

If a failed C2 Authorization Result is received from the USS, the SMF instead rejects the PDU establishment and include a reason code indicating not authorized.

7. [Conditional] If the C2 authorization is successful the USS subscribes via the UAS-NF to a PDU Session Status event for the PDU session used for C2 including in the request the GPSI of the UAV. The UAS NF determines DNN, S-NSSAI corresponding to the PDU session used for C2 communication and uses this DNN, S-NSSAI to subscribe to SMF for PDU Session Status event. The SMF detects, as described in step 6-7 of figure 4.15.3.2.3-1 in TS 23.502 [3], when the PDU Session is established and send the PDU Session Status event report to the UAS NF/NEF by means of Nsmf_EventExposure_Notify message, including GPSI and UE IP Address. The UAS NF/NEF then forwards the event message to the USS.
8. [Conditional] The USS stores the received UE IP address and invokes, with the received PDU Session IP address and the IP-address of the authorized paired UAV-C as input, the USS initiated pairing policy configuration procedure (see figure 5.2.5.2.4-1) to request corresponding traffic to be allowed on the PDU session by the UPF.

Unless a dedicated QoS is requested for the C2 flows, this procedure does not invoke any interaction with the UE, AMF or RAN.

5.2.5.3 Procedure for C2 authorization in EPS

5.2.5.3.0 C2 Authorization request during UUAA-SM procedure in EPS

If C2 authorization is requested during the UUAA-SM procedure the procedure described in clause 5.2.3.3 takes place with the following additions:

- In step 0, the UE includes pairing information (if available) in a C2 Aviation Payload, which is forwarded further to the USS.
- Initially in step 5, the USS performs C2 authorization taking into account the included pairing information, the Service Level Device Identity/CAA-Level UAV ID and 3GPP UAV ID/GPSI. The USS includes the resulting C2 Authorization result in the Naf_Authentication_AuthenticateAuthorize response returned to the UAS-NF/NEF and UAS NF/NEF forwards to the UAV/UE in step 8.
- The USS shall:
 - in step 5 include a DN Authorization profile Index specifying a predefined set of PCC-rules in the PCF with initial restriction on the type of traffic allowed to pass on the PDN Connection. For example, only traffic exchanged with the USS might be allowed to pass.

Once the authentication is complete, after step 5, the USS subscribes to PDN Connectivity Status Events for the PDN Connection used for C2 communication, applicable for the GPSI received in step 2.

- when the USS in step 9 receives a PDN Connectivity Status Event Report indicating session start and including the PDN Connection IP address, the USS invokes the USS initiated pairing policy configuration

procedure (see figure 5.2.5.4.2-1) with the received PDN Connection IP address and authorized paired UAV-C IP-address as input to request corresponding traffic to be allowed on the PDN Connection in the PGW-U.

5.2.5.3.1 UE requested PDN connectivity for C2 authorization

When the UAV requests to establish connectivity to an additional PDN over E-UTRAN for C2, the procedure described in clause 5.10.2 of TS 23.401 [6] takes place with the following modifications:

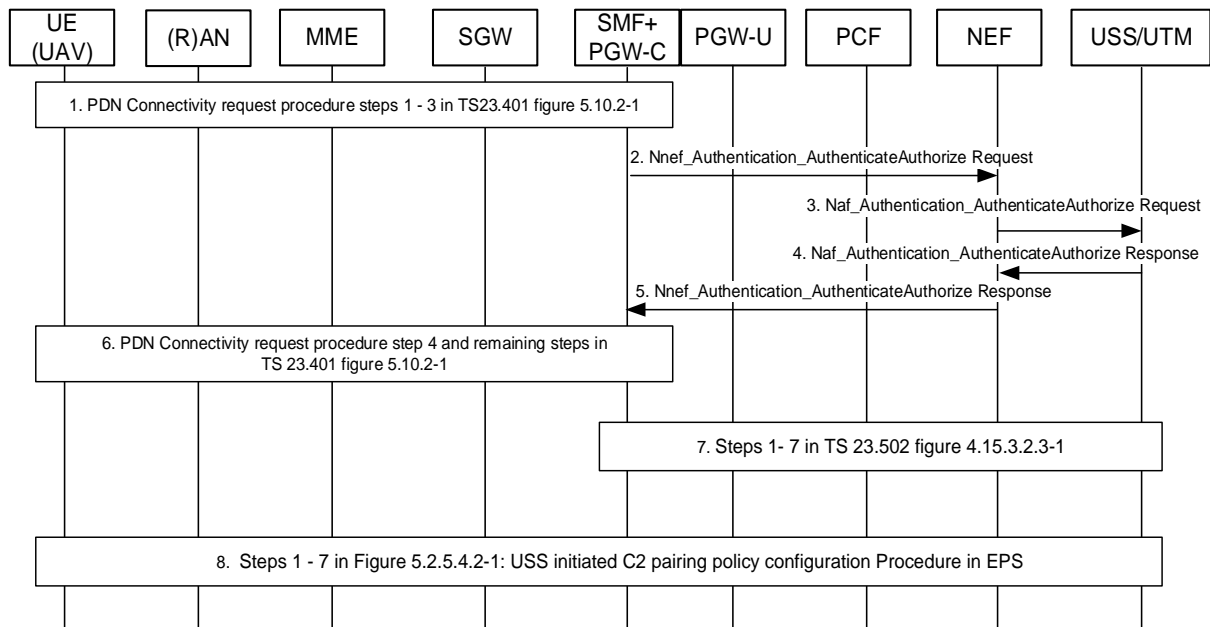

Figure 5.2.5.3.1-1: UE requested PDN Connectivity for C2 authorization

0. The UAV has performed a successful UAAA with the USS (UAAA-SM) and the USS has for the corresponding GPSI subscribed for PDN Connectivity Status Event reports from the NEF.
1. Steps 1 - 3 performed as in Figure 5.10.2-1 of TS 23.401 [6].

When the UAV needs to establish C2 communication, the UAV determines that a new PDN Connection is required for connectivity to UAV-C. The UE initiates a UE Requested PDN Connectivity procedure for connectivity to UAV-C. In the PCO in the PDN Connectivity Request, the Service Level Device Identity (e.g. the CAA-Level UAV ID) and a C2 Aviation Payload to be used for C2 authorization shall be included and forwarded to the MME. The pairing information includes the Service Level Device Identity (e.g. CAA-Level UAV IDs) of the requesting UAV and identification information for the UAV-C to pair may be included in C2 Aviation Payload. The UAV may also include other information such as Flight Authorization information. The USS may also use its locally configured pairing information for UAV - UAV-C pairing authorization which then takes precedence over UAV provided pairing information.

If Service Level Device Identity (CAA-Level UAV ID) is provided with the request, the SMF+PGW-C retrieves (if not already available) the Session Management Subscription Data for the UE from the UDM+HSS using the Nudm_SDM_Get service operation.

2. The SMF+PGW-C determines that authorization is required based on that the requested APN/DNN is dedicated for aerial services (have aerial service indicator set) and that the Service Level Device Identity (CAA-Level UAV ID) is included in the request. The SMF+PGW-C then sends a Nnef_Authentication_AuthenticateAuthorize request, which is used to request authorization to pair the UAV with UAV-C, to the UAS NF/NEF that includes the GPSI, Service Level Device Identity (e.g. the CAA-Level UAV ID) and C2 Aviation Payload and optionally the UAV location (e.g. Cell ID) if provided by the MME and the APN/DNN of the PDN Connection.

If the SMF+PGW-C determines that the authorization procedure with the USS is required, but the UAV has not provided the Service Level Device Identity (e.g. the CAA-Level UAV ID), the SMF+PGW-C rejects the PDN Connectivity Request with a cause indicating that USS authorization is required.

3. The UAS NF/NEF checks that a valid UUA is stored for the GPSI and forwards the received authorization request as a Naf_Authentication_AuthenticateAuthorize request to the USS. If not, the request is not forwarded to the USS and the PDN connection is rejected.
4. The USS performs C2 authorization based on the received information and sends the Naf_Authentication_AuthenticateAuthorize response to the UAS NF/NEF including the Service Level Device Identity (e.g. the CAA-Level UAV-ID) (potentially new), the C2 Authorization Result and the C2 Authorization Payload (e.g. C2 pairing information and C2 security information).
5. The UAS NF/NEF forwards the information received from the USS in the Nnef_Authentication_AuthenticateAuthorize response sent to the SMF+PGW C.
6. To inform the UE about the C2 authorization result the SMF+PGW-C includes the C2 Authorization Result and optionally, the Authorization Payload (e.g. C2 pairing information and C2 security information) and a new Service Level Device Identity (e.g. CAA-Level UAV ID) if received from the USS, in the PCO in the PDN Connectivity Accept sent to the UE and let the PDN Connectivity Request procedure continue until finalized.

If a failed C2 authorization result is received from the USS, the SMF+PGW-C instead rejects the PDN Connectivity Request and includes a cause code indicating not authorized.

7. If the C2 authorization is successful the USS subscribes via the UAS NF/NEF to a PDN Connection Status Event report for the PDN Connection used for C2 including in the request the GPSI of the UAV. The UAS NF/NEF determines the APN/DNN and uses this APN/DNN to subscribe to SMF+PGW-C for PDN Connection Status Event. The SMF+PGW-C detects, as described in step 6-7 of figure 4.15.3.2.3-1 in TS 23.502 [3], when the PDN Connection is established and sends the PDN Connection Status Event report to the UAS NF/NEF by means of Nsmf_EventExposure_Notify message, including GPSI and UE IP Address. The UAS NF/NEF then forwards the event message to the USS.
8. The USS stores the received UE IP address and invokes, with the received PDN Connection IP address and the IP-address of the authorized paired UAV-C as input, the USS initiated C2 pairing policy configuration in EPS procedure (see figure 5.2.5.4.2-1) to request corresponding traffic to be allowed on the PDN Connection by the PGW-U.

Unless a dedicated QoS is requested for the C2 flows, this procedure does not invoke any interaction with the UE, MME or RAN.

5.2.5.3.2 UE requested bearer resource modification of an existing PDN connection for C2 authorization

C2 authorization is requested at UE requested bearer resource modification (see clause 5.4.5 of TS 23.401 [6]):

- After UUA-SM is performed and a common PDN Connection is used for connectivity to USS and C2 communication to a UAV-C (as configured in the UAV); or
- If the UE has already established a PDN Connection for C2 communication to a UAV-C.

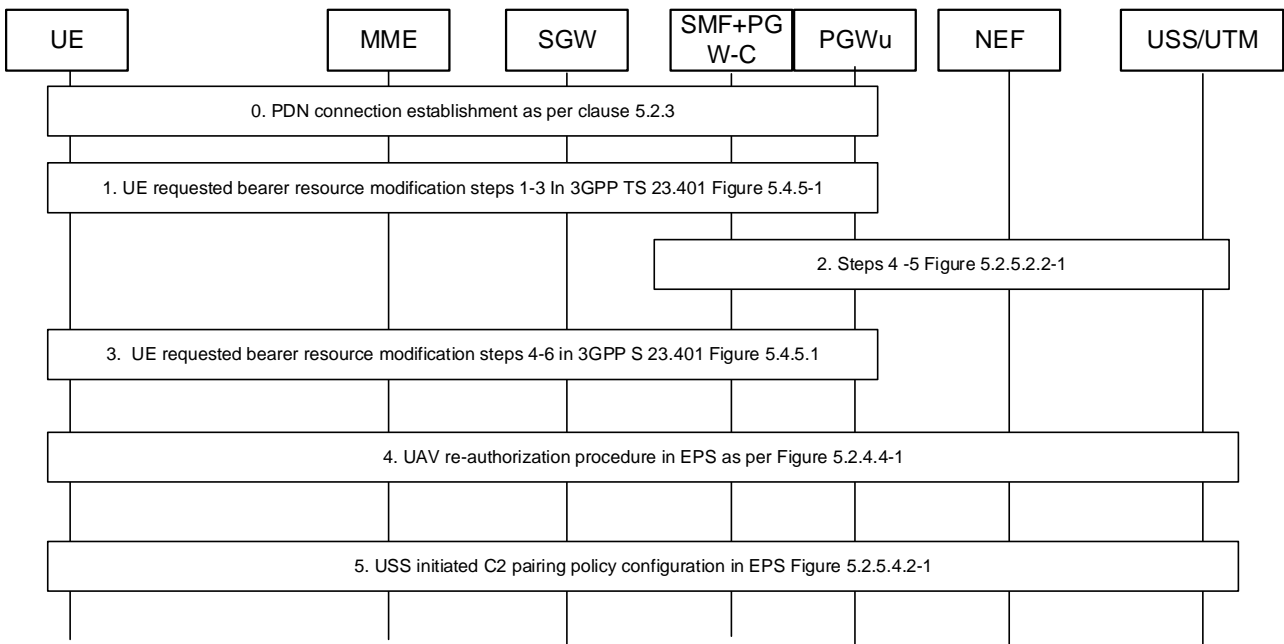

Figure 5.2.5.3.2-1: UE requested bearer resource modification of an existing PDN connection for C2 authorization

- 0. The UE establishes a PDN Connection for USS communication as described in clause 5.2.3.
- 1. When the UAV needs to establish C2 communication, the UAV determines that an existing PDN Connection can be used and initiates a UE requested bearer resource modification procedure as Steps 1 - 3 in Figure 5.4.5-1 of TS 23.401 [6]. In the PCO in the request, the UE includes a Service Level Device Identity (e.g. CAA-Level UAV ID) and shall include a C2 Aviation Payload that includes C2 authorization information. The USS may also use its locally configured pairing information for UAV - UAV-C pairing authorization which takes precedence over UAV provided pairing information. The pairing information includes the Service Level Device Identity (e.g. CAA-level UAV ID) of the requesting UE and also includes identification information of UAV-C to pair if available. The UAV may also include other information such as Flight Authorization information.

NOTE: How the pairing information is configured in the UAV is outside the scope of 3GPP specifications.

- 2. The SMF+PGW-C determines that authorization is required based on that the APN/DNN of the PDN Connection is dedicated for aerial services (have aerial service indicator set) and that the Service Level Device Identity (CAA-Level UAV ID) is included in the request and then sends a Nnef_Authentication_AuthenticateAuthorize request to the UAS-NF including the UAS information provided by the UAV in step 1 (including the C2 Aviation Payload), the Service Level Device Identity (e.g. CAA-Level UAV ID), GPSI, PDN Connection IP address, and optionally the UAV location (e.g. Cell ID) provided by the MME.

The UAS-NF forwards the received authorization request as a Naf_Authentication_AuthenticateAuthorize request to the USS.

- 3. The UE requested bearer resource modification procedure completes as in clause 5.4.5-1 of TS 23.401 [6].
- 4. Triggered by step 5, the USS performs C2 authorization based on the received information and invokes, in order to forward the C2 authorization result to the UAV/UE, the UAV Re-authorization procedure (see figure 5.2.4.4-1) including GPSI, Service Level Device Identity (e.g. CAA-Level UAV-ID) (potentially new) and, included in the authorization message, the C2 Authorization Result and the C2 Authorization Payload (e.g. containing C2 pairing information and C2 security information).
- 5. The USS invokes, with the received PDN Connection IP address and the IP address of the authorized paired UAV-C as input, the USS initiated pairing policy configuration procedure (see figure 5.2.5.4.2-1) to request corresponding traffic to be allowed on the PDN Connection in the UPF/PGW-U.

Unless a dedicated QoS is requested for the C2 flows, this procedure does not invoke any interaction with the UE, MME or RAN.

5.2.5.4 USS initiated C2 pairing policy configuration

5.2.5.4.1 USS initiated C2 pairing policy configuration in 5GS

The USS initiated C2 pairing policy configuration Figure 5.2.5.4.1-1.

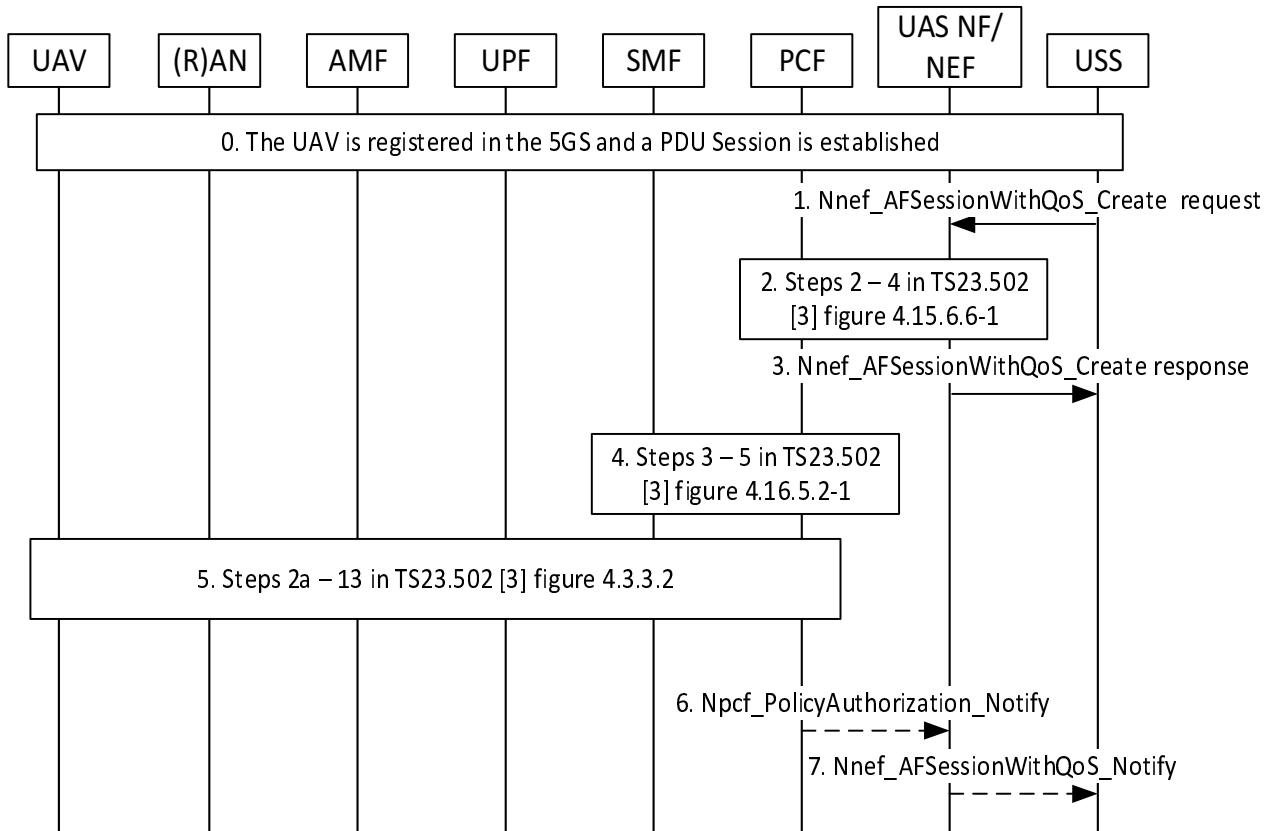

Figure 5.2.5.4.1-1: USS initiated C2 pairing policy configuration in 5GS

0. The UAV is registered in the network and a PDU session is established as specified in clause 5.2.3.2.

1. The USS initiates the PDU Session modification by invoking the Nnef_AFSessionWithQoS_Create request including USS Identity/AF Identifier, UAV-UAVC Pairing info/Flow description(s), QoS reference. The UAV-UAVC Pairing info/Flow description(s) includes the UAV-C IP address. See step 1 in clause 4.15.6.6 of TS 23.502 [3]: Setting up an AF session with required QoS.

2. UAS NF/NEF authorizes the request from the USS followed by interacting with PCF triggering a Npcf_PolicyAuthorization_Create request and provides relevant parameters to the PCF.

PCF determines whether the request is authorized and if the requested QoS is allowed. PCF informs UAS NF/NEF if the request is accepted by invoking Npcf_PolicyAuthorization_Create response. See steps 2 - 4 in figure 4.15.6.6.6-1 of TS 23.502 [3].

3. UAS NF/NEF sends a Nnef_AFSessionWithQoS_Create response message (Transaction Reference ID, Result) to the USS. Result indicates whether the request is granted or not. See step 5 in figure 4.15.6.6.6-1 of TS 23.502 [3].

NOTE: Use of Nnef_AFSessionWithQoS_Create can be further evaluated with stage 3 work.

4. If the PCF determines that the SMF needs updated policy information, the PCF issues a Npcf_SMPolicyControl_UpdateNotify request with updated policy information. The updated policy information includes the UAV-C IP address. See steps 3 - 5 in figure 4.16.5.2-1 of TS 23.502 [3].

5. The PDU Session Modification continues and completes as in steps 2a - 13 in figure 4.3.3.2-1 of TS 23.502 [3], UE or network requested PDU Session Modification (for non-roaming and roaming with local breakout). Based

on the updated policy information received, the SMF determines and provides N4 rules to enable communication between UAV and UAV-C, e.g. Packet Detection Rules, Forwarding Action Rules.

- 6-7. [Optional] The PCF sends Npcf_PolicyAuthorization_Notify message to the UAS NF/NEF when the modification of the transmission resources corresponding to the QoS update succeeded or failed. The UAS NF/NEF transfers this information to the USS by sending Nnef_AFSessionWithQoS_Notify message. See steps 6 and 7 in figure 4.15.6.6-1 of TS 23.502 [3].

5.2.5.4.2 USS initiated C2 pairing policy configuration in EPS

The USS initiated C2 pairing policy configuration in EPS figure 5.2.5.4.2-1.

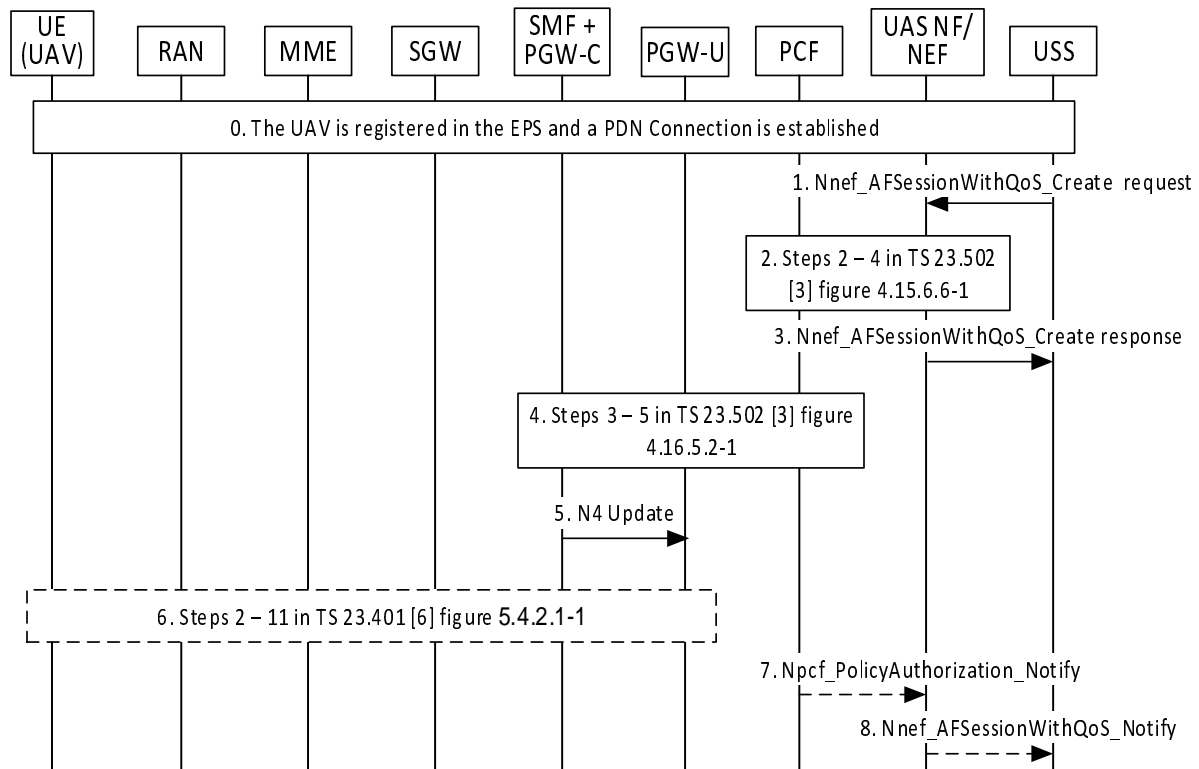

Figure 5.2.5.4.2-1: USS initiated C2 pairing policy configuration in EPS

- 0. The UAV is registered in the network and a PDN Connection is established as specified in clause 5.2.3.3.
- 1. The USS initiates the PDN Connection modification by invoking the Nnef_AFSessionWithQoS_Create request including USS Identity/AF Identifier, Transaction Reference ID, UAV-UAVC Pairing info/Flow description(s), QoS reference. The UAV-UAVC Pairing info/Flow description(s) includes the UAV-C IP address. See step 1 in clause 4.15.6.6 of TS 23.502 [3]: Setting up an AF session with required QoS.
- 2. UAS NF/NEF authorizes the request from the USS followed by interacting with PCF triggering a Npcf_PolicyAuthorization_Create request and provides relevant parameters to the PCF.

PCF determines whether the request is authorized and if the requested QoS is allowed. PCF informs UAS NF/NEF if the request is accepted by invoking Npcf_PolicyAuthorization_Create response. See steps 2 - 4 in figure 4.15.6.6-1 of TS 23.502 [3].
- 3. UAS NF/NEF sends a Nnef_AFSessionWithQoS_Create response message (Transaction Reference ID, Result) to the USS. Result indicates whether the request is granted or not. See step 5 in figure 4.15.6.6-1 of TS 23.502 [3].

NOTE: Use of Nnef_AFSessionWithQoS_Create can be further evaluated with stage 3 work.

4. If the PCF determines that the SMF+PGW-C needs updated policy information, the PCF issues a Npcf_SMPolicyControl_UpdateNotify request with updated policy information. The updated policy information includes the UAV-C IP address. See steps 3 - 5 in figure 4.16.5.2-1 of TS 23.502 [3].
5. Based on the updated policy information received, the SMF+PGW-C determines and provides N4 rules to enable communication between UAV and UAV-C, e.g. Packet Detection Rules, Forwarding Action Rules.
6. [Conditional] If QoS needs to be updated: Based on the updated policy information received, the SMF+PGW-C determines N4 rules for QoS update and provides to the PGW-U.

Based on the updated policy information received, the SMF+PGW-C invokes the PDN GW initiated bearer modification with bearer QoS update procedure (clause 5.4.2.1 in TS 23.401 [6]) by sending Update Bearer Request message to the SGW. Steps 2 - 11 in clause 5.4.2.1-1 of TS 23.401 [6] are executed to update QoS in the UE and the RAN.

- 7-8. [Optional] The PCF sends Npcf_PolicyAuthorization_Notify message to the UAS NF/NEF when the modification of the transmission resources corresponding to the QoS update succeeded or failed. The UAS NF/NEF transfers this information to the USS by sending Nnef_AFSessionWithQoS_Notify message. See steps 6 and 7 in figure 4.15.6.6-1 of TS 23.502 [3].

5.2.6 Void

5.2.7 UUA Revocation by USS/UTM

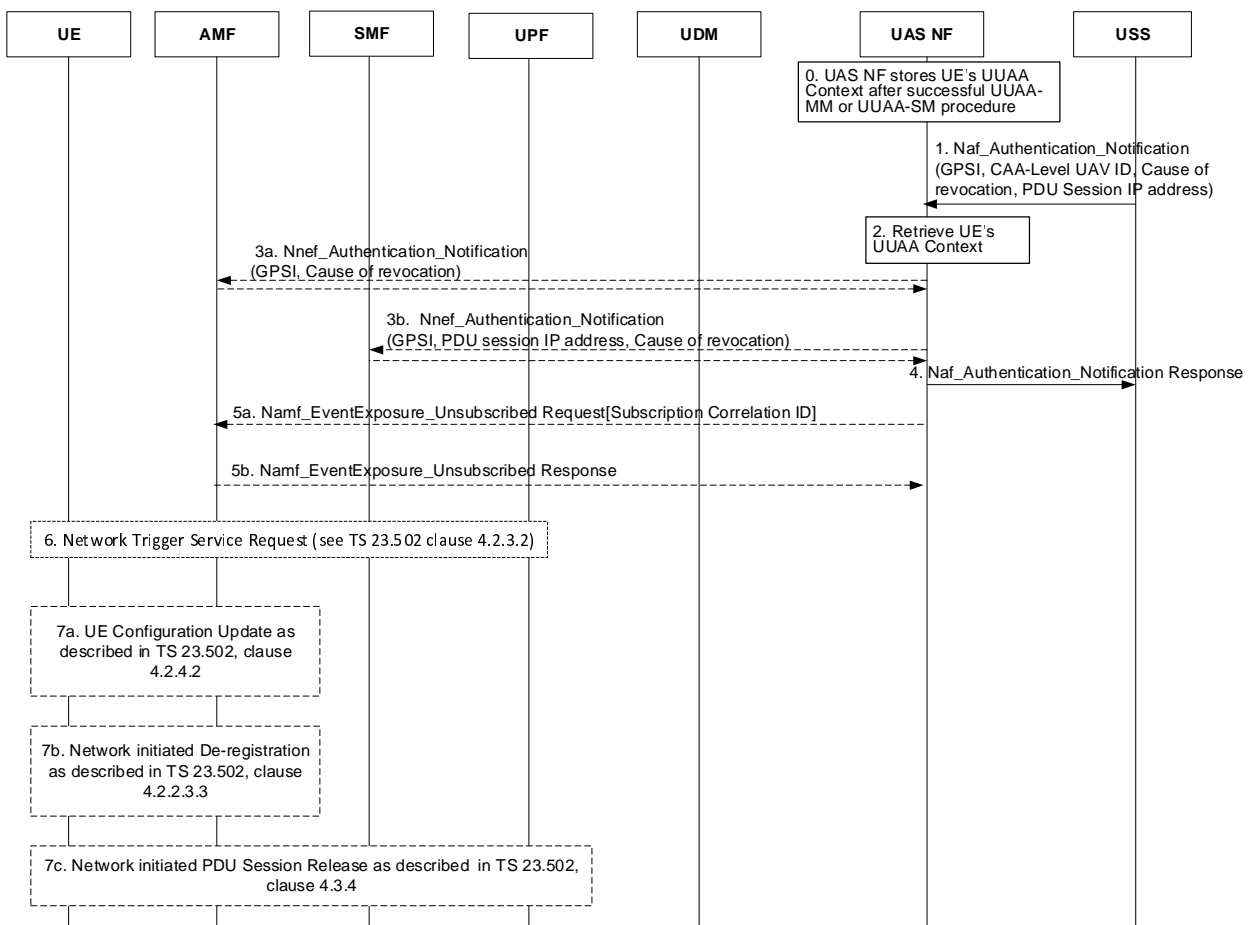

Figure 5.2.7.1-1: Procedure for UAV authorization revocation by USS

UAS NF stores the UAV UE's UUA context after successful UUA procedure as explained in clause 5.2.2.2 for UUA-MM and in clause 5.2.3.2 for UUA-SM procedure.

1. The USS sends Naf_Authentication_Notification to UAS NF for authorization revocation. The USS includes GPSI, CAA-Level UAV ID, cause of revocation, PDU Session IP address if available in the authorization revocation request.
2. UAS NF retrieves the UAV UE's stored UAAA context. From the stored UAAA context the UAS NF determines the target AMF or SMF for sending the notification.
- 3a or 3b. The UAS NF sends Nnef_Authentication_Notification request to notify the target NF, i.e. either the AMF or the SMF that the UAV is not authorized anymore, indicating the cause is revocation. The target NF shall remove the successful UAAA result and respond to the UAS NF.
4. The UAS NF shall remove the UAV UE's UAAA context. The UAS NF responds back to the USS indicating that authorization revocation request has been successfully initiated.
- 5a. If UAS NF has subscribed to AMF for the Mobility Event Exposure with Event ID = Reachability Filter before, UAS NF unsubscribes to AMF for the mobility event notification by sending Namf_EventExposure_Unsubscribe request with Subscription Correlation ID.
- 5b. The AMF acknowledges the un-subscription request from 5a by sending Namf_EventExposure_Unsubscribe response.
6. If UE is in CM_Idle state, the target NF (i.e. either the AMF or the SMF) initiates the Network Triggered Service Request procedures as described in clause 4.2.3.3 of TS 23.502 [3].
- 7a. If the target NF is AMF, the AMF shall initiate UE Configuration Update procedure as described in clause 4.2.4.2 of TS 23.502 [3] to inform the UE that UAAA is revoked. The AMF shall also initiate the release of PDU Sessions related to UAS services.
- 7b. If the target NF is AMF, based on network policy the AMF may start network initiated de-registration process as described in clause 4.2.2.3.3 of TS 23.502 [3].
- 7c. If the target NF is SMF, the SMF starts network initiated PDU session release process as described in clause 4.3.4 of TS 23.502 [3] to release the associated PDU session.

5.2.8 UAV Controller Replacement

5.2.8.1 UAV controller replacement in 5GS

If USS determines that UAV controller replacement is required the USS invokes an Nnef_AFsessionWithQoS_Update service operation to the UAS NF including in the request authorization information (i.e. new pairing information). NEF authorizes the request from the USS followed by interacting with PCF triggering a Npcf_PolicyAuthorization_Update request and provides relevant parameters to the PCF. The PCF uses the information provided by the NEF to derive new PCC rules to allow C2 communication between the UAV and the new UAV controller.

The procedure for UAV-C replacement is as follows:

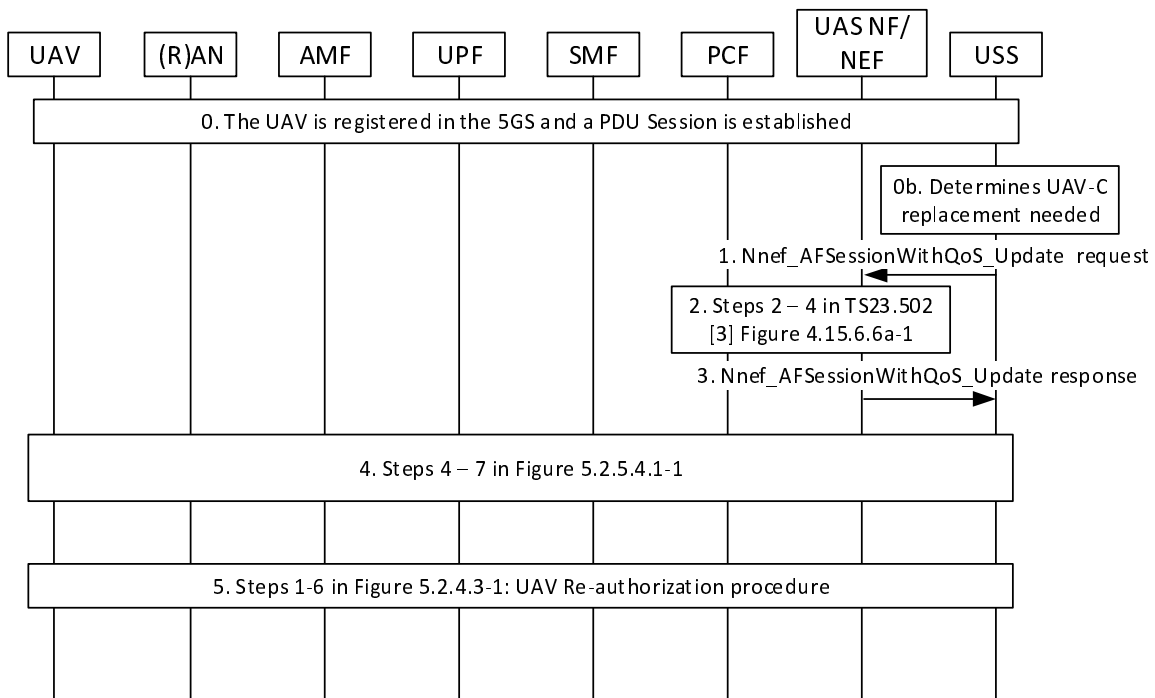

Figure 5.2.8-1: UAV-C replacement procedure

0. A UAV has already established user plane connectivity for C2 operation. The USS determines that the UAV-C controlling the UAV needs to be replaced (e.g. if the UAV is misbehaving).
1. The USS initiates the UAV-C replacement by invoking the Nnef_AFSessionWithQoS_Update request including Transaction Reference ID, UAV-UAVC Pairing info/Flow description(s), QoS reference. See step 1 in TS 23.502 [3] clause 4.15.6.6a, AF session with required QoS update procedure.
2. NEF authorizes the request from the USS followed by interacting with PCF triggering a Npcf_PolicyAuthorization_Update request and provides relevant parameters to the PCF. PCF determines whether the request is authorized and if the requested QoS is allowed. PCF informs NEF if the request is accepted by invoking Npcf_PolicyAuthorization_Update Response. See Steps 2 - 4 in TS 23.502 [3] figure 4.15.6.6.6a-1.
3. NEF sends a Nnef_AFsessionWithQoS_Update response message (Transaction Reference ID, Result) to the USS. Result indicates whether the request is granted or not. See step 5 in TS 23.502 [3] figure 4.15.6.6.6a-1.
4. Steps 4 - 7 in Figure 5.2.5.4.1-1.
5. USS invokes the UAV Re-authorization procedure in Figure 5.2.4.3-1 to deliver the new pairing information to the UE. The USS includes the 3GPP UAV ID, the IP address of the PDU session and included in the authorization message the C2 Authorization Result and the C2 Authorization Payload (containing the C2 pairing information containing the new UAV-C identifier and C2 security information) which is further forwarded to the UE.

5.2.8.2 UAV controller replacement in EPS

The procedure for UAV-C replacement in EPS is as follows:

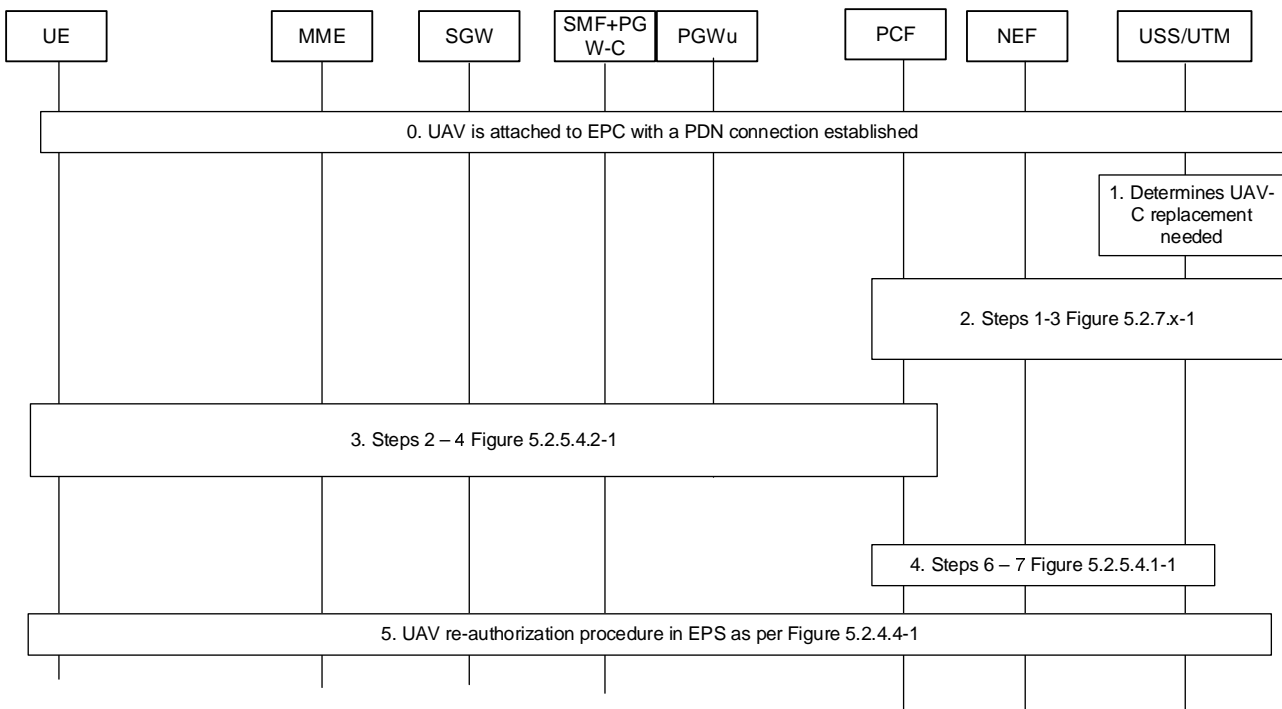

Figure 5.2.8.2-1: UAV controller replacement in EPS

0. UAV is attached to EPC with a PDN connection established
1. The USS determines that the UAV-C controlling the UAV needs to be replaced (e.g. if the UAV is misbehaving).
2. USS initiates the Nnef_AFSessionWithQoS_Update request including USS Identity/AF Identifier, Transaction Reference ID, UAV-UAVC Pairing info/Flow description(s), QoS reference. Steps 1-3 as in Figure 5.2.7.1-1 takes place.
3. The PCF determines updated policy information and configures the resources and routing information as in steps 2 - 4 in Figure 5.2.5.4.2-1.
4. The USS is informed whether the UAV-C replacement and authorization has succeeded or failed as in steps 6- 7 in Figure 5.2.5.4.1-1.
5. The USS invokes the UAV re-authorization procedure in EPS as in Figure 5.2.4.4-1. The USS includes the 3GPP UAV ID, the IP address of the PDU session and included in the authorization message, the C2 Authorization Result and the C2 Authorization Payload (e.g. containing the C2 pairing information containing the new UAV-C identifier and C2 security information) which is further forwarded to the UE.

5.2.9 Revocation of C2 Connectivity

5.2.9.1 Revocation of C2 connectivity in 5GS

When the USS decides to revoke an existing C2 connection between the UAV and UAV-C the USS invokes an Nnef_AFsessionWithQoS_Revoke request to NEF in order to revoke the AF request as described in Figure 5.2.9.1-1.

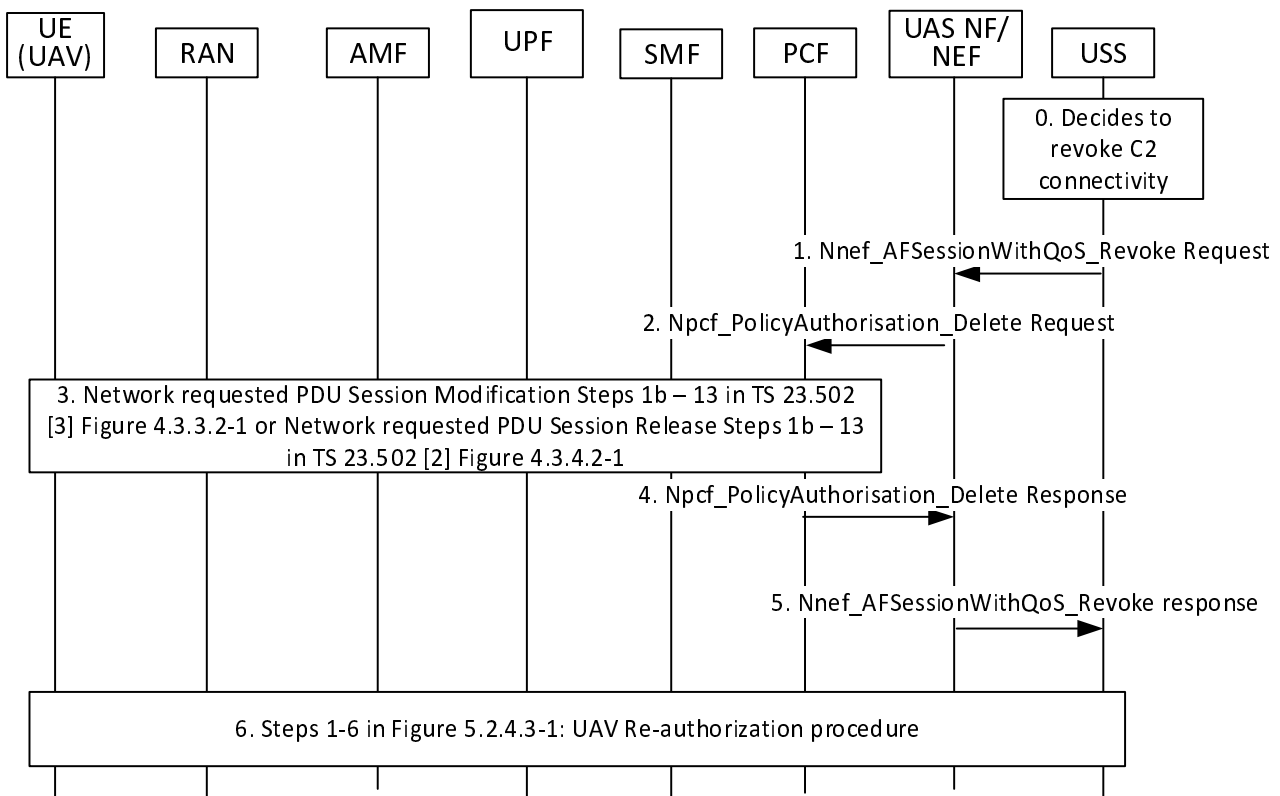

Figure 5.2.9.1-1: Revocation of C2 connectivity in 5GS

0. USS decides to revoke C2 connectivity.
 1. USS identifies the AF session corresponding to the C2 connectivity and invokes an Nnef_AFSessionWithQoS_Revoke Request including USS identity/AF identifier, Transaction Reference ID.
 2. UAS NF/NEF indicates to the PCF to delete the context of application level session information by invoking an Npcf_PolicyAuthorization_Delete request.
 3. The PCF initiates a network requested PDU session modification procedures as in steps 1b-13 in Figure 4.3.3.2-1 of TS 23.502 [3] removing the corresponding PCC rules installed at the SMF to support the AF session or may trigger a network requested PDU session release as in Steps 1b-13 Figure 4.3.4.2-1 of TS 23.502 [3].
 4. The PCF acknowledge the request by sending an Npcf_PolicyAuthorization_Delete response.
- NOTE: Steps 3 and 4 can be carried out in parallel.
5. The UAS NF/NEF acknowledge the USS request by sending an Nnef_AFSessionWithQoS_Revoke response.
 6. USS may invoke the UAV Re-authorization procedure in Figure 5.2.4.3-1 to deliver a C2 authorization payload indicating that C2 authorization has been revoked.

5.2.9.2 Revocation of C2 connectivity in EPS

The procedure is as follows:

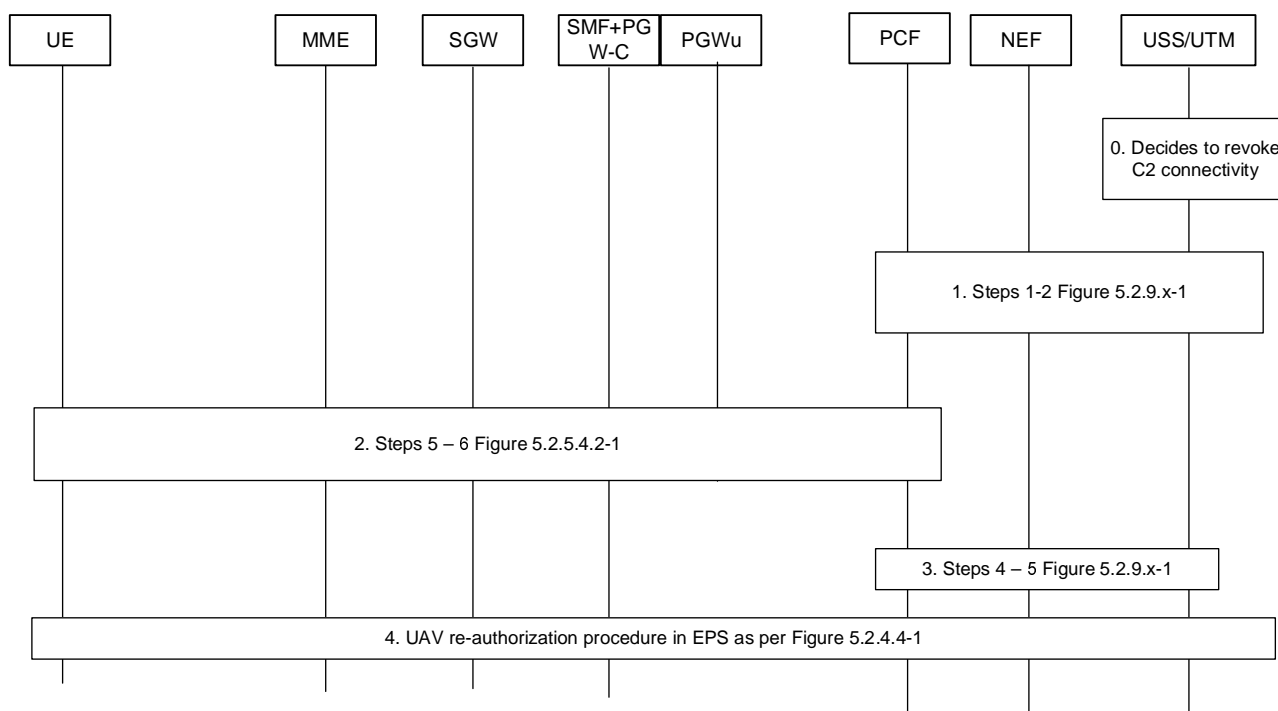

Figure 5.2.9.2-1: Revocation of C2 connectivity in EPS

0. USS decides to revoke C2 connectivity.
1. Steps 1 - 2 as described in Figure 5.2.9.1-1 are performed.
2. The PCF deletes policy information associated with the AF session and configures the resources and routing information as in steps 5 - 6 in Figure 5.2.5.4.2-1.
3. Steps 4-5 as described in Figure 5.2.9.1-1 are performed.

NOTE: Step 2 in Figure 5.2.9.2-1 and step 4 in Figure 5.2.9.1-1 can be carried out in parallel.

4. The USS may invoke the UAV re-authorization procedure in EPS as in Figure 5.2.4.4-1 to deliver a C2 authorization payload indicating that C2 connectivity is revoked.

5.3 UAV Tracking

5.3.1 UAV Tracking Model

3GPP network supports the functionality of UAV Tracking via the service exposure support towards USS. The USS invokes 3GPP network service through a UAS-NF for UAV tracking. The UAS-NF acts as an NEF/SCEF and interacts with other network functions (e.g. GMLC and AMF/MME) to support UAV tracking. The USS shall use 3GPP UAV ID (e.g. GPSI) for identifying an individual target UAV. When USS/TPAE initiates UAV tracking via USA NF, it should include an indication of reliable UE location information required in the request. For further details on the architecture reference model, see clause 4.2.

Three UAV tracking modes are supported:

- UAV location reporting mode;
- UAV presence monitoring mode; and
- List of Aerial UEs in a geographic area..

USS/TPAE could at any time choose a UAV tracking mode and provide the corresponding request to UAS NF. The USS/TPAE logic on its choice of UAV Tracking Model is out of scope of 3GPP.

The 3GPP network may also provide the UAV location to the USS during the UUA procedures, as described in clause 5.2.2 and clause 5.2.3.

5.3.1.1 UAV Location Reporting Mode

For UAV location reporting mode, the USS/TPAE that wants to be reported on the UAV location subscribes to the UAS NF with the target 3GPP UAV ID. The USS/TPAE could indicate the required location accuracy, reliable UE location information required and whether it's for immediate reporting or deferred reporting (e.g. periodic reporting). With the request received from USS/TPAE, UAS NF identifies the related NF, i.e. GMLC and trigger existing procedures to retrieve the location report. Then UAS NF reports back the UAV's location together with the 3GPP UAV ID to the USS/TPAE.

5.3.1.2 UAV Presence Monitoring Mode

For UAV presence monitoring mode, the USS/TPAE may subscribe for the event report of UAV moving in or out of the geographic area (e.g. longitude/latitude, zip code, etc). The request includes target 3GPP UAV ID, indication of reliable UE location information required and geographic area info.

If the requested geographic area info can be mapped to 3GPP defined area, such as a list of Tracking Areas or a list of cells as currently supported by 3GPP network as the Area Of Interest, UAS NF subscribes to AMF/MME for reporting the presence of the UAV in Area Of Interest using existing AMF/MME procedures, otherwise UAS NF subscribes to GMLC for configuring the presence monitoring. Upon receiving the report from AMF/MME or GMLC, the UAS NF notifies USS/TPAE for the UAV presence in the geographic area.

The USS may provide policies or rules to UAS NF based on the received event notification. If the traffic routing policies or rules were provided to UAS NF, when the location of UAV or the UAV presence in the monitoring area matches a policy, UAS NF based on the policy indicates SMF to take the appropriate network layer actions, e.g. revoke the connectivity between UAV and UAV controller. UAS NF considers those policies as active and ongoing instructions from USS without constant or repeated triggers/requests from USS. The traffic routing policy includes 3GPP UAV ID(s) (i.e. GPSI(s)) to identify the UAV(s) and the corresponding network layer actions e.g. revoke the resources of the related C2 communications.

5.3.1.3 List of Aerial UEs in a geographic area

In this mode, the USS/TPAE requests UAS NF for a list of the UAVs in the geographic area and served by the PLMN (i.e. no 3GPP UAV ID provided by the USS/TPAE). The request includes geographic area info, indication of reliable UE location information required and indication of one-time reporting by setting "maximumNumberOfReports" to 1. If the geographic area info can be mapped to 3GPP defined area such as a list of Tracking Areas or a list of cells, UAS NF triggers existing AMF/MME procedures to get the UE list within the TAI(s) or Cell Id(s). The UAS NF may include Aerial UE indication as an event filter in the request, that is used by the AMF/MME to separate out the UEs that are actual UAVs based UEs with aerial subscriptions. If the geographic area info cannot be mapped to 3GPP defined area such as a list of Tracking Areas or a list of cells, UAS NF provides a list of Tracking Areas which is larger than the geographic area to AMF/MME to retrieve the UE list within the list of Tracking Areas. Then UAS NF identifies UAVs from the UE list and obtains the location for each identified UAV via LCS procedure toward GMLC. The UAS NF compares the UAV location with the geographic area to identify the UAVs in the geographic area and provides feedback to USS/TPAE. For the UAV list received from the AMF/MME or the UAV list identified with GMLC provided location, the UAS NF performs the filtering by checking for each 3GPP UAV ID reported whether there is match for the corresponding UAV context. The UAS NF may also verify whether the requesting USS is authorized to obtain the location info of the UAV.

In the above UAV tracking modes, UAS NF may need to map the 3GPP UAV ID to 3GPP internal IDs and vice versa. The CAA Level UAV ID may be optionally provided by the UAS NF, if available, to the USS/TPAE during tracking and location reporting of UAV.

5.3.2 Procedure for UAV location reporting

The following procedures describe the 5GC UAV's location reporting service to USS.

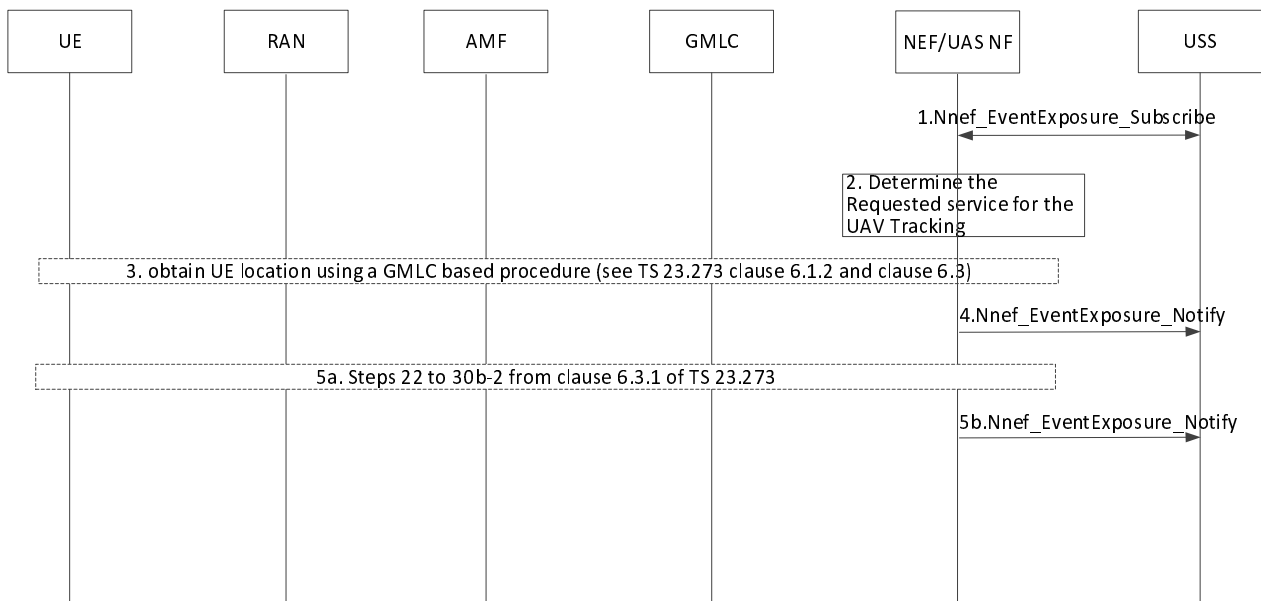

Figure 5.3.2-1: UAV Location Reporting

1. USS to UAS NF/NEF: The USS sends Nnef_EventExposure_Subscribe request to the UAS NF/NEF as described in step 1b-1 from clause 6.1.2 of TS 23.273 [8] for immediate location reporting (i.e. 5GC-MT-LR) and step 1b-1 from clause 6.3.1 of TS 23.273 [8] for periodic, triggered and UE available location reporting (i.e. deferred 5GC-MT-LR). USS should include an indication of reliable UE location information required in the request.
2. UAS NF/NEF determines the relevant NF, i.e. GMLC for location reporting based on the UAV's capability or network capability, location accuracy etc.
3. UAS NF sends request to GMLC with the GPSI (i.e. 3GPP UAV ID) provided by USS to retrieve the UE location via the current location services supported by GMLC. The UAS NF/NEF performs 5GC-MT-LR Procedure as described in clause 6.1.2 of TS 23.273 [8] or deferred 5GC-MT-LR procedure as described in clause 6.3.1 (up to step 21b-1) of TS 23.273 [8] depending on whether the request received in step 1 was for immediate location reporting or deferred location reporting respectively.
4. UAS/NEF NF to USS: UAS NF/NEF provides the UAV location to USS/TPAE in Nnef_EventExposure_Notify operation as described in step 24b-2 of Figure 6.1.2-1, if the request in step 1 was for immediate location reporting. The UAS NF/NEF includes the GPSI in the location reporting message to USS/TPAE as well as the UAV's location information (in the form of geo co-ordinates) which is understood by USS/TPAE (not assuming the knowledge of TA and Cell Id).

If the request in step 1 was for deferred 5GC-MT-LR, the UAS NF/NEF sends Nnef_EventExposure_Notify indicating whether or not the periodic or triggered location was successfully activated in the target UE, as described in step 21b-2 of Figure 6.3.1-1.
5. For deferred 5GC-MT-LR with periodic or triggered location request steps 22 to 30b-2 of Figure 6.3.1-1 are executed and the UAS NF/NEF provides the location report to USS/TPAE in Nnef_EventExposure_Notify operation.

5.3.3 Procedure for UAV presence monitoring

The following procedures describe the 3GPP UAV presence monitoring mode operation.

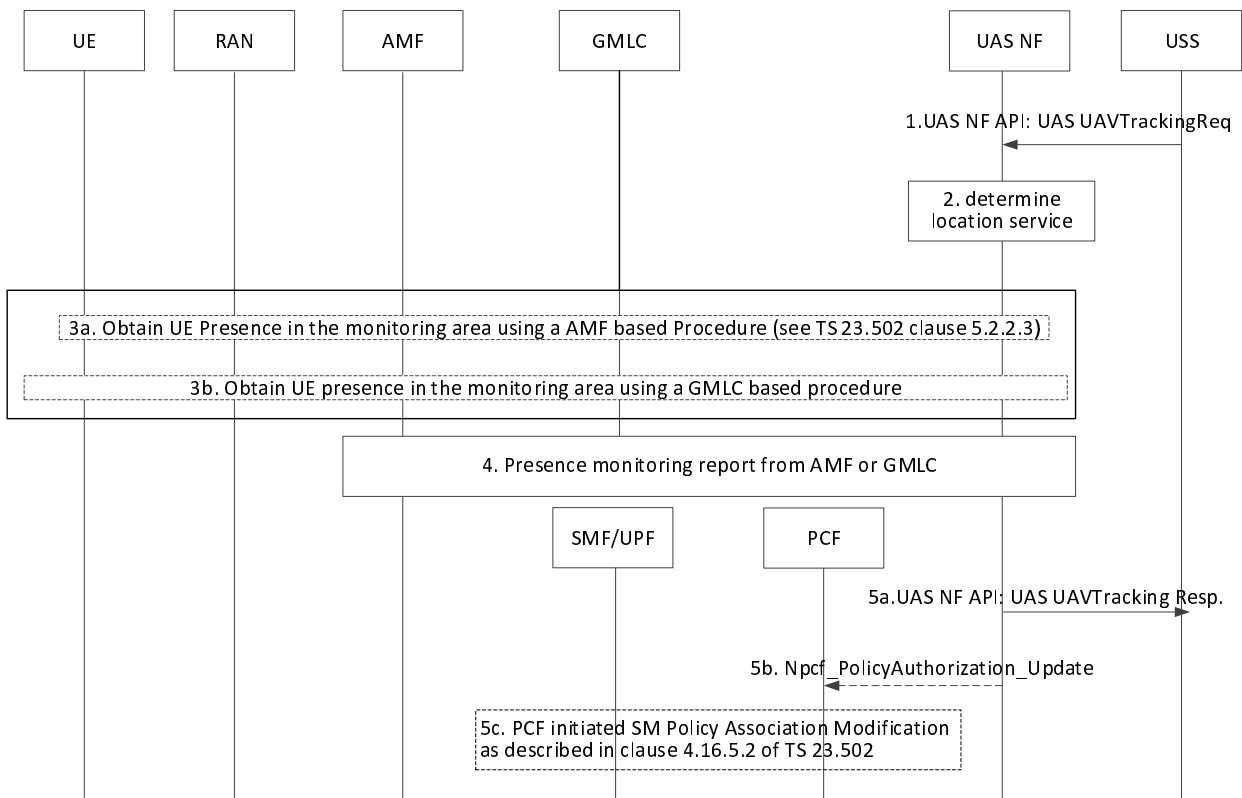

Figure 5.3.3-1: UAV Presence Monitoring

1. USS to UAS NF/NEF: The USS initiates the UAV presence monitoring request via the Nnef_EventExposure_Subscribe service operation to UAS NF/NEF to subscribe to the target UAV presence events from 3GPP network (e.g. moving in or out of the monitoring area). In addition to providing a GPSI corresponding to the target UAV for the presence monitoring, the request also includes the geographic area info (e.g. longitude/latitude, zip code, etc.), an indication of reliable UE location information required. Optionally, it includes a policy or rule indicating the 3GPP network to take the corresponding action when the Area of Interest (AOI) event report is detected. The policy or rule contains a moving in or moving out event associated with an indication of revoking the connectivity between UAV and UAV controller.
2. UAS NF/NEF maps the geographical area into an area of interest that is represented by a list of Cell IDs, gNB IDs or TAIs, and determines the relevant NF (s), i.e. AMF or GMLC for location reporting based on the UAV's capability or network capability, the geographic area info etc.
- 3a. If the requested geographic area info can be mapped to 3GPP defined area and the relevant NF is determined as AMF in step 2, then the UAS NF/NEF maps the GPSI provided by USS to SUPI, and provides the SUPI and the mapped 3GPP defined area to the AMF to obtain the UE presence status by reusing the Area of Interest mechanism.
- 3a. If the requested geographic area info cannot be mapped to 3GPP defined area and the relevant NF is determined as GMLC in step 2, then the UAS NF/NEF uses GMLC based procedure for configuring the presence monitoring. It is preferable for UAS NF/NEF to use GMLC based procedure if presence monitoring is needed in a granularity finer than the Cell Id. The UAS NF/NEF invokes an Ngmlc_Location_ProvideLocation Request service operation towards the GMLC including the geographical area of interest for presence monitoring. The UAS NF/NEF may first use AMF based procedure for UE presence monitoring as described in step 3a before invoking GMLC service.
4. UAS NF/NEF receives the UAV presence monitoring report from AMF or GMLC.
- 5a. UAS NF/NEF reports the UAV presence in the geographic area to USS by including its GPSI in the report. The CAA Level UAV ID, if available with the UAS NF/NEF, may be optionally provided in the report.
- 5b-5c. [Optional] If policies have been provided to UAS NF/NEF in step1 from USS, when the UAV presence in the monitoring area matches a policy, UAS NF/NEF based on the policy indicates SMF (via PCF) to take the appropriate network layer actions, e.g. revoke the connectivity between UAV and UAV controller, etc. The UAS

NF/NEF uses the Npcf_PolicyAuthorization_Update service operation as described in clause 4.15.6.6a of TS 23.502 [3] and provides relevant parameters to the PCF. UAS NF/NEF considers those policies as active and ongoing instructions from USS without constant or repeated triggers/requests from USS. The PCF issues a Npcf_SMPolicyControl_UpdateNotify request with updated policy information received from the UAS NF/NEF about the PDU Session as described in the PCF initiated SM Policy Association Modification procedure in clause 4.16.5.2.

5.3.4 Procedure for obtaining list of Aerial UEs in a geographic area

This procedure may be used by USS/TPAE to obtain a list of the UAVs in a geographic area and served by the PLMN. The USS/TPAE provides the geographic area information to the UAS-NF. Based on the received information, the UAS NF may either trigger the AMF/MME monitoring event configuration procedure with event ID "Number of UEs present in a geographical area" or the GMLC based location reporting procedure. The AMF/MME may filter the list of UAVs before sending it to the UAS NF (e.g. may filter only based on UE having Aerial subscription), if Aerial UE indication was included as an event filter in the monitoring event configuration request from the UAS NF. The UAS NF performs the filtering on the received list from AMF or MME before responding back to the USS/TPAE. The UAS-NF includes the 3GPP UAV ID and may include the CAA Level UAV ID, if available, for each of the UAVs in the tracking and location response to the USS/TPAE.

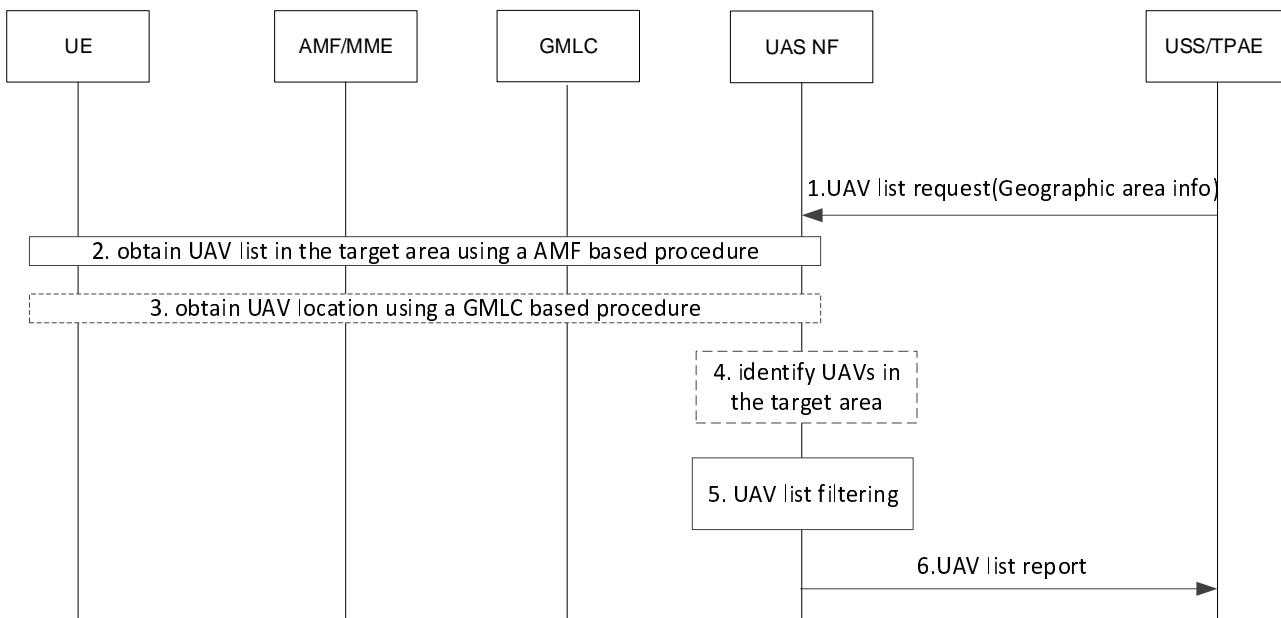

Figure 5.3.4-1: List of Aerial UEs in a geographic area

1. USS to UAS NF: The USS/TPAE sends the UAV list request to UAS NF to request UAV identity (e.g. 3GPP UAV ID, CAA Level UAV ID). The USS/TPAE includes geographic area info, an indication of reliable UE location information required and indication for immediate reporting in the request message to the UAV-NF.
2. UAS NF to AMF/MME: UAS NF decides the AMF(s) based on the geographic area info and obtains the UE list in the target area from AMF by reusing the event "Number of UEs present in a geographical area" with any UE in the event filter. The UAS NF may also include "Aerial UE" indication and/or "PDU session established for DNN(s) subject to aerial service" as event filters. If the target area cannot be mapped to 3GPP network areas, UAS NF provides a TA List which is larger than the target area to the AMF(s)/MME(s) for the list of UEs to be queried. The AMF(s)/MME(s) identifies UEs corresponding to the geographic area info and may also filter out the list of UAVs based on checking for UEs with aerial subscriptions, if "Aerial UE" indication was included as an event filter in the request from UAS NF/NEF. In addition, the AMF(s) may also further identify UAVs that have successfully established PDU session for DNN(s) subject to aerial services, if it was included as an event filter in the request from UAS NF/NEF.
3. [Optional] UAS NF to GMLC: From the list of UEs generated in step 2, for UAVs that are in target areas that do not map to 3GPP network areas, the UAS-NF then queries the UAV(s) location from GMLC.

4. [Conditional] If step 3 above was executed, from the list of locations returned by the GMLC, the UAS NF compares the UAV's locations to the target area (provided in step 1 above) to identify the UAV to be included in the report for USS.
5. For either the UAV list received from the AMF(s)/MME(s), or the UAV list identified in step 4, the UAS NF performs the filtering by checking for each reported 3GPP UAV ID whether there is match for the corresponding UUAA context.
6. UAS NF to USS: UAS NF responds to the USS/TPAE with the list of filtered UAVs (step 5). The CAA Level UAV ID, if available, may be provided by the UAS NF in the response message to USS/TPAE. If the USS performed the UUAA of the UAV, or the UAS NF is configured to know the USS is authorized to receive such information, then the 3GPP UAV ID is also included.

5.4 Direct C2 Communication

5.4.1 General

A UAV that supports Direct C2 Communication may establish direct PC5 link with a UAV-C. Only NR PC5 is supported for Direct C2 Communication. The UAV that is engaged in Direct C2 Communication may or may not be capable of connection with 3GPP network. The UAV is authorized by the USS for establishing Direct C2 Communication with the UAV-C. The UAV-C with which the UAV performs Direct C2 Communication may be pre-configured in the UAV or provided by the network as described in clause 5.4.3. The UAV may be preconfigured with the A2X service type for direct C2 Communication, direct C2 pairing information (e.g. Application Layer ID of the UAV-C), a default Destination Layer-2 ID for initial signalling to establish unicast connection, authorization policy for direct C2 Communication.

5.4.2 Authorization policy for A2X Direct C2 Communication service

Authorization policy parameters as described in clause 6.2.1.2.1 for A2X are leveraged using a service type indicating Direct C2 Communication where applicable.

5.4.3 Procedure for C2 authorization by the USS for using the A2X Direct C2 Communication service

5.4.3.1 General

If the UAV is capable of 3GPP network connection and is served by a PLMN, the UAV performs the Direct C2 Communication authorization either as part of the UUAA-MM procedure in 5GS described in clause 5.2.2 or as part of the C2 Authorization during UUAA-SM procedure described in clause 5.2.5. In either case, if the UAV supports Direct C2 Communication and intends to request C2 authorization for Direct C2 Communication to the USS, it shall include an indication for Direct C2 Communication authorization in the authorization request.

If the UAV is not capable of 3GPP network connection or is not in coverage of a PLMN at the moment of performing authorization of Direct C2 Communication, or when the UAV does not use any PLMN resources for UAS services, Direct C2 Communication is authorized based on pre-configured policies in the UAV (e.g. at the application layer).

5.4.3.2 Authorization of Direct C2 Communication service via UUAA-MM

In 5GS, the UUAA-MM procedure may be used to authorize direct C2 communication described in clause 5.2.2 with the following enhancements:

- In step 1 of clause 5.2.2.1: When the UAV needs to establish a direct PC5 link required for connectivity to UAV-C (i.e. Direct C2 Communication), the UAV may include an authorization request for Direct C2 Communication by providing a C2 Aviation Payload with an indication that the authorization is for Direct C2 Communication. In addition, the UAV includes the direct C2 pairing information (if available) in the C2 Aviation Payload.
- In steps 2 and 3 of clause 5.2.2.2: if the UAV included the C2 Aviation Payload in step 1 of clause 5.2.2.1, the C2 Aviation Payload is also included

- In steps 5 and 6 of clause 5.2.2.2: If the authorization request for Direct C2 Communication was included in step 1 of clause 5.2.2.1, the USS sends the C2 Authorization result and in the case of success, may include a direct C2 pairing information containing the UAV-C's Application Layer ID in the C2 Authorization Payload, which are further forwarded to the UAV/UE.

If the UAV attempts Direct C2 Communication authorization via UAAA-MM and receives no response, the UAV shall perform Direct C2 Communication via UAAA-SM.

5.4.3.3 Authorization of Direct C2 Communication service via UAAA-SM

In 5GS, the following procedures are used to request C2 authorization for Direct C2 Communication to the USS:

- The procedure for C2 Authorization request during UAAA-SM procedure in 5GS as specified in clause 5.2.5.2.1 with the following enhancements:
 - In step 0: When the UAV needs to establish a direct PC5 link required for connectivity to UAV-C (i.e. Direct C2 Communication), the C2 Aviation Payload sent by the UAV includes an indication that the authorization is also for Direct C2 Communication. In addition, the UAV includes the direct C2 pairing information (if available) in the C2 Aviation Payload.
 - In step 4: If the authorization request for Direct C2 Communication was included in step 0 and the C2 authorization is successful, the USS may include direct C2 pairing information containing the UAV-C's Application Layer ID in the C2 Authorization Payload which is further forwarded to the UAV/UE.
- The procedure for UE initiated PDU Session Modification for C2 Communication as specified in clause 5.2.5.2.2 with the following enhancements:
 - In step 2: When the UAV needs to establish a direct PC5 link required for connectivity to UAV-C (i.e. Direct C2 Communication), the C2 Aviation Payload sent by the UAV includes an indication that the authorization is also for Direct C2 Communication. In addition, the UAV includes the direct C2 pairing information (if available) in the C2 Aviation Payload.
 - In step 6: If the authorization request for Direct C2 Communication was included in step 2 and the C2 authorization is successful, the USS may include direct C2 pairing information containing the UAV-C's Application Layer ID in the C2 Authorization Payload which is further forwarded to the UAV/UE.
- The procedure for UE initiated PDU Session Establishment for C2 Communication as specified in clause 5.2.5.2.3 with the following enhancements:
 - In step 1: When the UAV needs to establish a direct PC5 link required for connectivity to UAV-C (i.e. Direct C2 Communication), the C2 Aviation Payload sent by the UAV includes an indication that the authorization is also for Direct C2 Communication. In addition, the UAV includes the direct C2 pairing information (if available) in the C2 Aviation Payload.
 - In step 4: If the authorization request for Direct C2 Communication was included in step 1 and the C2 authorization is successful, the USS may include direct C2 pairing information containing the UAV-C's Application Layer ID in the C2 Authorization Payload which is further forwarded to the UE in the Naf_Authentication_AuthenticateAuthorize response.

In EPS, the following procedures are used to request C2 authorization for Direct C2 Communication to the USS:

- The procedure for C2 Authorization request during UAAA-SM procedure in EPS as specified in clause 5.2.5.3.0 with the following enhancements:
 - In step 0: When the UAV needs to establish a direct PC5 link required for connectivity to UAV-C (i.e. Direct C2 Communication), the C2 Aviation Payload sent by the UAV includes an indication that the authorization is also for Direct C2 Communication. In addition, the UAV includes the direct C2 pairing information (if available) in the C2 Aviation Payload.
 - In step 5: If the authorization request for Direct C2 Communication was included in step 0 and the C2 authorization is successful, the USS may include direct C2 pairing information containing the UAV-C's Application Layer ID in the C2 Authorization Payload which is further forwarded to the UAV/UE.
- The procedure for UE requested PDN connectivity for C2 authorization as specified in clause 5.2.5.3.1 with the following enhancements:

- In step 1: When the UAV needs to establish a direct PC5 link required for connectivity to UAV-C (i.e. Direct C2 Communication), the C2 Aviation Payload sent by the UAV includes an indication that the authorization is also for Direct C2 Communication. In addition, the UAV includes the direct C2 pairing information (if available) in the C2 Aviation Payload.
- In step 4: If the authorization request for Direct C2 Communication was included in step 1 and the C2 authorization is successful, the USS may include direct C2 pairing information containing the UAV-C's Application Layer ID in the C2 Authorization Payload which is further forwarded to the UAV/UE.
- The procedure for UE requested bearer resource modification of an existing PDN connection for C2 authorization as specified in clause 5.2.5.3.2 with the following enhancements:
 - In step 1: When the UAV needs to establish a direct PC5 link required for connectivity to UAV-C (i.e. Direct C2 Communication), the C2 Aviation Payload sent by the UAV includes an indication that the authorization is also for Direct C2 Communication. In addition, the UAV includes the direct C2 pairing information (if available) in the C2 Aviation Payload.
 - In step 4: If the authorization request for Direct C2 Communication was included in step 1 and the C2 authorization is successful, the USS may include direct C2 pairing information containing the UAV-C's Application Layer ID in the C2 Authorization Payload which is further forwarded to the UAV/UE.

5.4.4 Procedure for Direct C2 Communication establishment

The procedures for Direct C2 Communication leverages A2X Unicast mode communication over PC5 reference point as defined in clause 6.2.2.1.3 and clause 6.3.3.2.

To establish Direct C2 communication the procedure for A2X unicast mode Layer-2 link establishment over PC5 reference point as defined by clause 6.3.3.2 and the accordingly referred description in clause 6.3.3.1 of TS 23.287 [11] with the following enhancements and differences:

- In step 3:
 - the A2X Service Info is set to A2X service type for direct C2 Communication. The A2X service type for direct C2 Communication may be preconfigured in the UAV.
 - the Source User Info is set to the Application Layer ID of the UAV.
 - the Target User Info is set to the Application Layer ID of the UAV-C. If the Application Layer ID of the UAV-C is provided by the network as described in clause 5.4.3, that Application Layer ID is used. Otherwise, the preconfigured Application Layer ID of the UAV-C is used.
 - The destination Layer-2 ID is set to a default Destination Layer-2 ID for initial signalling to establish unicast connection as preconfigured in the UAV.

In this Release, only Unicast mode communication over PC5 reference point is supported for Direct C2 Communication.

NOTE: Security aspects of Direct C2 Communication is defined by SA WG3.

5.5 Broadcast Remote ID

5.5.1 Broadcast Remote ID using PC5

Broadcast Remote ID leverages A2X broadcast communication mode as defined in clauses 6.2.2.1.2 and 6.3.3.1, for both UAV UEs that register to the MNO network(s) and UAVs that operate out of coverage.

The content of the messages for BRID is defined according to regional regulations for BRID (e.g. message set of ASTM F3411.19 [13] or ASD-STAN prEN 4709-002 P1 [14]) and optionally according to regional mean of compliance documents.

Authorization and provisioning of policy parameters for A2X communication over PC5 reference point as described in clause 6.2.1.2 is leveraged. Where applicable, an A2X service type indicating Broadcast Remote ID is used.

5.5.2 Broadcast Remote ID using MBS

5.5.2.1 Policy/Parameter provisioning

Policy parameters provisioning as described in clause 6.2.1.3 for A2X communication over Uu reference point is leveraged. Where applicable an A2X service type indicating Broadcast Remote ID is used.

5.5.2.2 Broadcast Remote ID reception via MBS

The A2X Broadcast Remote ID service is identified with a corresponding service type.

The Broadcast Remote ID sent by a UAV UE to an A2X application server identified by A2X service type set to Broadcast Remote ID is as a A2X message routed to UAV UEs via MBS sessions using the mechanisms and procedures described in clause 6.2.2.2.2.

The content of the A2X message is the Broadcast Remote ID, e.g. as defined in ASTM F3411.19 [13] or ASD-STAN prEN 4709-002 P1 [14].

5.5.2.3 QoS handling

QoS is handled as described in clause 6.2.4.2 for delivery of A2X message over MBS.

5.5.2.4 MBS service area mapping

Broadcast Remote ID using MBS facilitates procedures and mechanisms for MBS service area mapping for A2X communication with MBS as specified in clause 6.3.4.2.1 in accordance with:

- UE applies to a UAV UE.

5.6 Mechanisms for Detect and Avoid (DAA)

5.6.1 Mechanisms for Detect and Avoid (DAA) based on PC5

DAA leverages procedures and mechanisms as defined for A2X in clause 6. This includes the corresponding references to TS 23.287 [11] below.

NOTE 1: The content of the messages for DAA are defined according to the regional regulations for DAA and is out of scope of 3GPP.

The detection and deconfliction of potential collisions between UAVs is locally performed between UAVs using direct UAV to UAV communication over PC5. The USS may be informed of the potential collision situation.

Deconflicting policy which indicates the communication mode (unicast or broadcast) used for deconflicting for A2X is defined in 6.2.1.2.1.

Authorization and provisioning of policy parameters for A2X communication over PC5 reference point as described in clause 6.2.1.2 is leveraged.

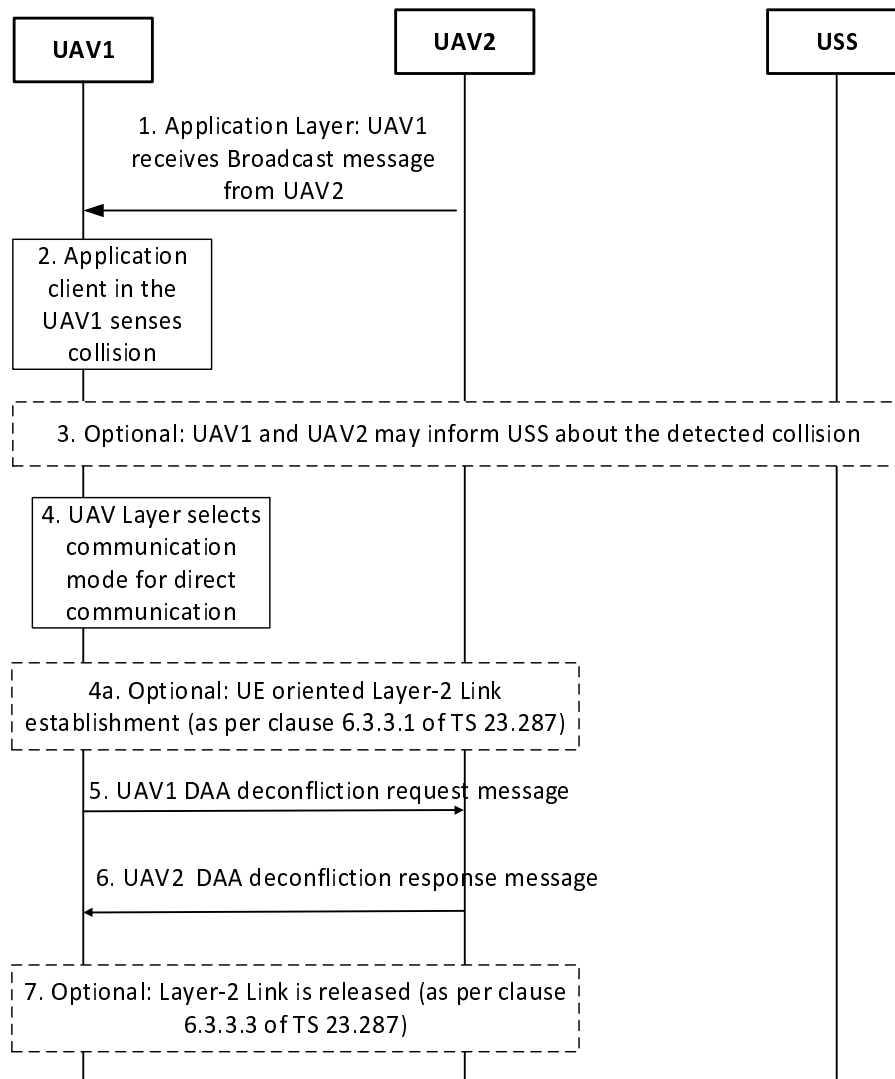

Figure 5.6.1-1: DAA procedure based on PC5

1. UAV1 receives broadcast messages from UAV2 in PC5-U messages, that may include application layer DAA payload, e.g. CAA-level UAV ID, velocity, heading direction, position.
2. UAV1 passes the DAA payload to the upper layer. The application layer detects a conflict, based on the broadcast messages received from UAV2, e.g. by comparing it with its own trajectory and location. If the application layer in the UAV1 detects a potential collision situation, it initiates a collision avoidance/conflict resolution procedure with UAV2.
3. Optionally, UAV1 may inform its own USS about the detected potential collision by including peer UAV2 ID(s).

NOTE 2: The communication between UAV and USS for potential collision notification is out of scope of this specification.

4. UAV1 selects a communication mode (broadcast or unicast) for DAA deconfliction based on the input received from the application layer and A2X Policy. If unicast deconfliction mode is selected then step 4a is executed, otherwise, messages in steps 5 and 6 are exchanged using broadcast mode as defined in clause 6.3.1 of TS 23.287 [11].
- 4a. Optional: If unicast deconfliction mode is selected, then UAV1 triggers Layer-2 link establishment for unicast communication with UAV2 by applying to A2X the procedure defined in clause 6.3.3.1 of TS 23.287 [11] with the following clarifications:
 - If the Target User Info is included in the Direct Communication Request message, Application layer ID of the target UE (UAV2) can be the one retrieved from the step 1, e.g. CAA-level UAV ID.

- If the Target User Info is not included in the Direct Communication Request message, the UEs that are interested in using the announced A2X service type(s) over a PC5 unicast link with UAV1 responds by establishing the security with the UAV1.

The steps 5 and 6 are then exchanged over the established unicast link.

5. UAV1 sends to UAV2 a DAA deconfliction message, e.g. deconfliction request message which may include collision detection alert, its CAA-level UAV IDs and the one(s) from other detected conflicting UAV(s), and deconflicting specific parameters (e.g. trajectory correction information to avoid collision).

NOTE 3: The deconflicting specific parameters are application layer content and is out of scope of this specification.

6. UAV2 replies to provide agreed DAA deconflicting policy, its updated trajectory and other info, e.g. message deconfliction status response, conflict resolved alert, CAA-level UAV IDs of participating UAVs from the receiving UAV.

Subsequent messages may be exchanged between UAVs until traffic conflict resolution is reached (e.g. for mutual position/trajectory monitoring) based on application layer mechanisms.

7. After the successful traffic conflict resolution, if unicast deconfliction mode was selected, the UAV1 triggers Layer-2 link release procedure as described in clause 6.3.3.3 of TS 23.287 [11].

NOTE 4: While it is assumed that all UAVs in the area can be involved for DAA, the procedure shows only two UAVs for simplicity.

5.7 Ground-based DAA for an Area

5.7.1 Functional Description

This clause provides a network-assisted (ground based) DAA mechanism. It is applicable for a specific area, such as a stadium or arena where UAVs are used e.g. for filming an event. It is based on a ground-based entity, Area Airspace Manager (AAM), that is able to detect UAVs in the specific area and provide local steering policies to the individual UASs in order to avoid the UAVs crashing into each other or different structures etc. The policy may e.g. include allowed flying zones and positions allowed for the specific UAV. The policy may also apply to a specific outdoor area, e.g. an event, where specific measures to avoid collision between drones are established locally.

NOTE 1: The policies provided by the AAM is application specific steering/DAA policies that are out of scope of 3GPP. The same or different local policies can be provided to the UAVs in the arena. UAVs can, for example, be given different fly zones in the arena just like people have different seating in an arena.

The high-level principles of the network-assisted (ground based) DAA are:

- The arena/area has a ground-based entity Area Airspace Manager (AAM). The AAM includes one or more UEs enabled for use of PC5. The AAM may also have a direct connection to the Data Network.
- For the applicable airspace of the area/arena the AAM defines individually adapted local collision avoidance rules for correspondingly located UAVs.

NOTE 2: How the AAM can determine the local steering policy for collision avoidance is out of scope of 3GPP. It can e.g. be based on maps of the area/arena and detailed information about the facilities together with an awareness of the current usage need for the airspace.

- Provisioning of AAM local collision avoidance rules to a UAV/UE must comply with the policies for PC5 operations received from the 5GC or being preconfigured in the UE.
- Detected UAVs are identified by their coordinates and by the Remote ID as retrieved by Broadcast Remote ID (BRID) or Network Remote ID (NRID) mechanisms dependent on the method used by the UAV.

NOTE 3: How the AAM can scan the UAVs in specific area is out of scope of 3GPP.

NOTE 4: How the AAM retrieves the Remote ID for detected UAVs is out of scope of 3GPP. For example, in case of BRID different UAVs can use different methods, such as WLAN, Bluetooth or PC5 direct communication, for broadcasting the Remote ID and in case of NRID the AAM will, based on the geolocation of the UAV, retrieve the Remote ID from the USS at application layer. For the NRID case the AAM will typically have to be authorized by the UTM to be allowed to retrieve the Remote ID.

- Based on the retrieved Remote ID, the AAM activates PC5 communication with each detected UAV by triggering establishment of an A2X PC5 unicast link based on procedures described in clause 6 using the UAV's Remote-ID as Application-Layer-ID (i.e. Target User Info) in the Direct Communication Request message.

For Direct Communication over PC5 the UAV and AAM shall comply with the authorization and provisioning principles described in clause 4.2.1.2.2 including the following considerations:

- The default destination Layer-2 ID to be used for initial signalling to establish a unicast connection for the A2X service.
- Parameters for Groupcast are not applicable.

NOTE 5: Use of LTE PC5 for the unicast is not supported in this Release.

- The AAM uses PC5 unicast link to provide each UAV present in the arena/area with local DAA policies as user traffic.
- A UAV that receives local collision avoidance related policies from the AAM over PC5 may forward the policies to its UAV-C so that the UAV-C can steer the UAV accordingly by use of C2 communication (e.g. over Uu, PC5, or other means) in order to enforce the local policies and avoid collisions.

NOTE 6: Whether and how to forward the policies from UAV to its UAV-C and how UAV-C uses the policies is out of scope of 3GPP.

NOTE 7: A UAV-C that receives local collision avoidance policies from an AAM, can inform the AAM about its network address (e.g. IP address or URL) in order to enable direct AAM to UAV-C communication via Data Network. How a UAV-C communicates with the AAM is out of scope of 3GPP.

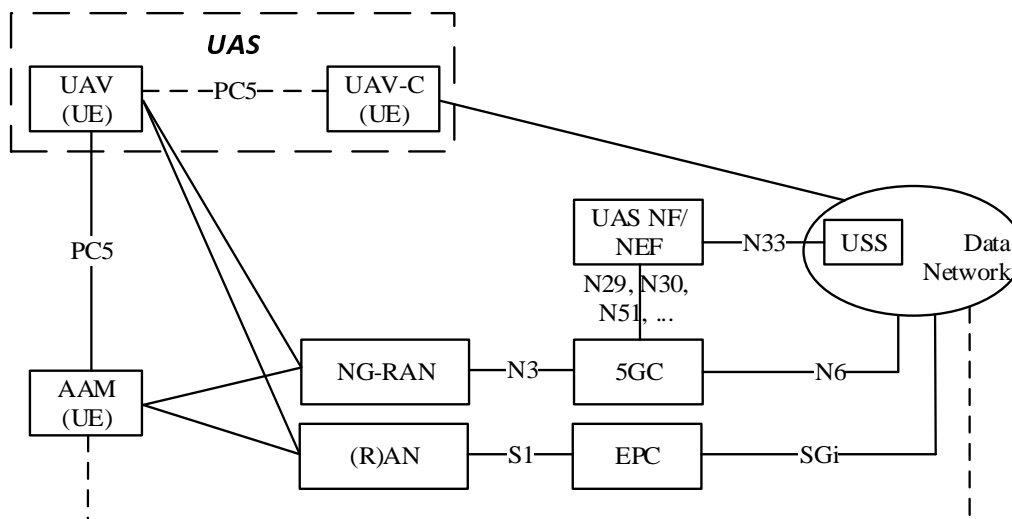

Figure 5.7.1-1: Logical architecture for ground based DAA

5.7.2 Procedures

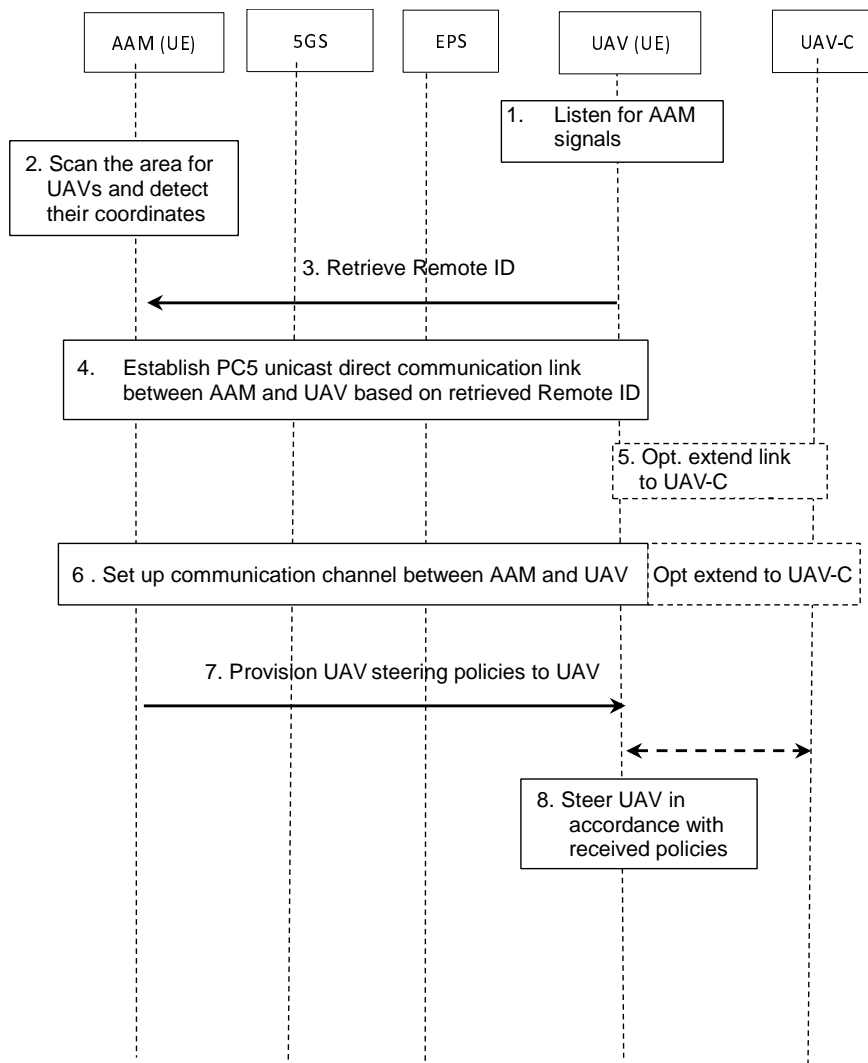

Figure 5.7.2-1: High-level procedure for Ground-based DAA for an Area

Ground-based DAA for an area leverages the procedures and mechanisms defined for A2X. Any references to TS 23.287 [11] made in this clause shall be interpreted in accordance with corresponding definitions and descriptions for A2X in clause 6.

Prerequisites: The AAM/UE and the UAVs/UEs are configured to use an A2X service for Ground-based DAA for an area.

1. The UAVs/UEs listens for signals on the correspondingly destination Layer-2 ID configured for the used service type in accordance with clause 6.3.3.1 of TS 23.287 [11] (Fig 6.3.3.1-1 step 1).
2. The AAM can scan the airspace over the area/arena for UAVs, e.g. by making use of upward pointing radars and cameras etc. For each detected UAV it determines the coordinates.

NOTE 1: How step 2 and step 3 are done is out of 3GPP scope.

3. The AAM retrieves for each detected UAV the corresponding Remote-ID using the method applicable for the specific UAV. Methods which may be used includes broadcast of Remote-ID via PC5, WiFi and Bluetooth and also Network Remote ID.

How this is done is out of the 3GPP scope.

4. For each detected UAV/UE the AAM establishes a PC5 direct communication link with the discovered UAV for AAM to UAS interaction by performing the Layer-2 link establishment procedure as described when Target

User Info is included in clause 6.3.3.1 of TS 23.287 [11] (Fig 6.3.3.1-1 step 2, 3 4a, 5a and 6). The AAM application layer provides a service type indicating the A2X service "Ground-based DAA for an area" and the retrieved Remote-ID as target UE's Application Layer ID. As a result of this procedure a PC5 unicast direct communication link enabling bidirectional data exchange is set up between the application layer in the AAM and the UAV application layer of the UAV/UE having the specified Remote-ID.

5. Optionally the UAV/UE may, when the PC5 unicast direct communication link between the AAM and the UAV/UE has been set up for NR, activate a corresponding bidirectional communication connection extending the link from the UAV to the UAV-C using the specific communication technology used for C2 communication (may e.g. be LR Wi-Fi or PC5). This enables packets received on the link (i.e. from the AAM) to be forwarded to the UAV-C and packets received from the UAV-C to be forwarded on the link (i.e. towards the AAM). Implementation aspects for this step are out of scope for 3GPP.
6. Using the PC5 unicast direct communication link the AAM and the UAV establishes a bidirectional communication channel for exchange of messages. Optionally this channel can be extended to involve the UAV-C using the bi-directional tunnel. The protocol and implementation aspects for this step are out of scope for 3GPP.

NOTE 2: The UAV-C and/or the UAV can use the communication channel to provide application specific information to the AAM, how and what information is out of 3GPP scope. Based on awareness of the current UAV traffic situation, local info and plans for the area/arena, the AAM determines locations and flight paths appropriate for the specific UAV such that collisions can be avoided and creates a corresponding application specific steering policy being out of scope of 3GPP.

7. The AAM provides the determined steering policy to the specific UAV using the activated communication channel. Optionally it can be forwarded to the UAV-C which can return corresponding C2 commands. Protocols, semantics and syntax for handling this are application specific and out of 3GPP scope.
8. The UAV is steered to avoid collisions in accordance with received policy and using mechanisms that are out of scope for 3GPP.

NOTE 3: A UAV-C that optionally receives local policies for DAA from an AAM, can inform the AAM of its address (e.g. IP address or URL) to enable direct AAM to UAV-C communication via Data Network.

5.8 Void

5.9 Void

5.10 Void

5.11 Void

6 Aircraft-to-Everything (A2X) services

6.1 Architecture model and concepts

6.1.1 General concept

There are two modes of operation for A2X communication, namely A2X communication over PC5 reference point and A2X communication over Uu reference point. These two operation modes may be used by a UE independently of different A2X communications.

A2X communications over PC5 reference point are supported by LTE and/or NR.

A2X communications over Uu reference point are supported by NR connected to 5GC.

A2X leverages both LTE PC5 as defined in TS 23.285 [12] and NR PC5. For LTE PC5 in EPS, the network scheduled operation mode defined in TS 23.285 [12] is not supported and the A2X uses only the UE autonomous resources selection mode.

Groupcast mode for NR based PC5 is not supported.

Subscription to A2X services based on the user's profile stored in the UDM is supported as described in clause 6.2.5.

Both UAV UEs that utilize Uu connectivity and that do not utilize Uu connectivity (i.e. either UAV UEs that are Uu capable and do not use Uu) are supported. A UAV without utilizing Uu capabilities may use A2X for C2 communication, BRID and DDAA and be configured via A2X1 over a transport outside the scope of 3GPP.

NOTE 1: UAV UEs without utilizing Uu capabilities are part of the 3GPP ecosystem since they use A2X1 for configuration by a A2X Application Server and implement PC5 connectivity specified by 3GPP.

Both UAVs with UICC and UAVs without UICC (i.e. with no subscription to an MNO) are supported. UAVs with no UICC can only perform A2X communications when authorized for "not served by E-UTRA" and "not served by NR".

No specific authorization of the use of PC5 for A2X services (i.e. BRID, DDAA, Ground based DAA) is required by the USS. For UAVs without UICC, or UAVs with UICC that are out of coverage or are served by a PLMN where UUAA has not been performed, the use of PC5-based communications for A2X services is authorized only by A2XP via pre-configuration or A2X1.

In this version of the specification, UAV UEs may support A2X capability for A2X communication over PC5 reference point and/or A2X capability for A2X communication over Uu reference point.

In this Release, communication over PC5 between the UAV UEs served by different PLMNs is possible in NR when the UAV UEs use the same sidelink carrier.

UAV UEs that use the UE autonomous resources selection based on pre-configuration for NR PC5 can communicate over NR PC5 independently of the serving PLMN. The UE shall support the procedures described in clause 5.1.2.2 of TS 23.287 [11], for both E-UTRA and NR, so that the UE can perform A2X communications over PC5 reference point when "not served by E-UTRA" and "not served by NR". The UE, in order to perform these procedures, shall reliably locate itself in the corresponding Geographical Area. Otherwise, the UE is not authorized to transmit.

NOTE 2: It is out of scope of the present specification to define how the UE can locate itself in a specific Geographical Area. When the UE is in coverage of a 3GPP RAT, it can for example, use information derived from the serving PLMN. When the UE is not in coverage of a 3GPP RAT, it can use other techniques, e.g. Global Navigation Satellite System (GNSS). User provided location is not a valid input.

NOTE 3: It is assumed that any security of A2X solution is addressed by SA WG3.

NOTE 4: The A2X application layer schemes developed in other SDOs are outside the scope of this specification.

6.1.2 Architectural reference model

6.1.2.1 PC5 and Uu based A2X architecture reference model

6.1.2.1.1 Non-roaming 5G System architecture for A2X communication over PC5 and Uu reference points

Clause 4.2.3 describes the non-roaming architectures for A2X communications.

6.1.2.1.2 Roaming 5G System architecture for A2X communication over PC5 and Uu reference points

Clause 4.2.4 describes the roaming architectures for A2X communications.

6.1.2.1.3 Inter-PLMN 5G System architecture for A2X communication over PC5 reference point

In the case of inter-PLMN A2X communication over PC5 reference point, the PC5 parameters need to be configured in a consistent way among the UEs within a certain region. The architecture for the Inter-PLMN PC5 case is similar to the one defined in clauses 4.2.3 and 4.2.4.

6.1.2.2 AF-based service parameter provisioning for A2X communication

The 5G System provides NEF services to enable communication between NFs in the PLMN and A2X Application Server. Figure 6.1.2.2-1 shows the high level view of AF-based service parameter provisioning for A2X communications. The A2X Application Server may provide A2X service parameters to the PLMN via NEF. The NEF stores the A2X service parameters in the UDR. The NEF stores the A2X service parameters in the UDR.

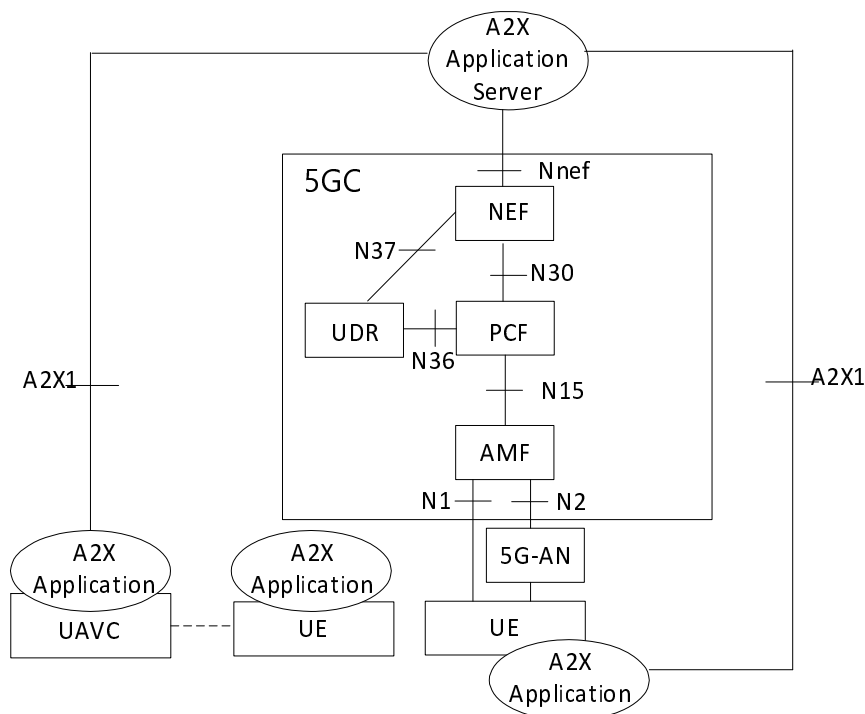

Figure 6.1.2.2-1: 5G System architecture for AF-based service parameter provisioning for A2X communications

6.1.2.3 MBS for Uu based A2X architecture reference model

A2X leverages what is defined for V2X in TS 23.287 [11] clause 4.2.2A with the following differences:

- V2X is replaced by A2X.

6.1.2.4 Reference points

See clause 4.2.6.

6.1.2.5 Service-based interfaces

See clause 4.2.5.

6.1.3 Functional entities

See clause 4.3.

6.2 High level functionality and features

6.2.1 Authorization and Provisioning for A2X communications

6.2.1.1 General

Authorization and provisioning of parameters for A2X communication leverages V2X mechanisms as defined in TS 23.287 [11] clause 5.1.1 with the following differences:

- V2X is replaced by A2X.
- The V1 reference point is replaced by the A2X1 reference point.
- The set of parameters defined for A2X are described in clause 6.2.1.2.1 and 6.2.1.3.1.
- The means for PCF including A2X policy/parameters into a Policy section identified by a Policy Section Identifier (PSI) as specified in clause 6.1.2.2.2 of TS 23.503 [9].

6.2.1.2 Authorization and Provisioning for A2X communications over PC5 reference point

6.2.1.2.1 Policy/Parameter provisioning

A2X leverages what is defined for V2X in TS 23.287 [11] clause 5.1.2.1 with the following differences:

- V2X is replaced by A2X.
- The V1 reference point is replaced by the A2X1 reference point.
- Tx Profiles for LTE PC5 are not required.
- Groupcast related policy/parameters are not required.
- In addition to existing parameters for V2X, the radio parameters per PC5 RAT (i.e. LTE PC5, NR PC5) can be configured with Altitude Range per Geographical Area. This additional information may be needed to enable policing the use of PC5 depending on the specific location of the UAV.
- Addition of:
 - Deconflicting policy which indicates the communication mode (unicast or broadcast) used for deconflicting is defined for A2X.

NOTE: How frequently a UAV sends deconfliction-related messages is an application layer aspect outside the scope of 3GPP.

6.2.1.2.2 Principles for applying parameters for A2X communications over PC5 reference point

A2X leverages what is defined for V2X in TS 23.287 [11] clause 5.1.2.2 with the following differences:

- V2X is replaced by A2X.
- The V1 reference point is replaced by the A2X1 reference point.

6.2.1.3 Authorization and Provisioning for A2X communications over Uu reference point

6.2.1.3.1 Policy/Parameter provisioning

The following set of information may be provisioned to the UAV UE for A2X communication over the Uu reference point using MBS:

- 1) Mapping of the A2X service type to A2X Application Server address information (consisting of IP address/FQDN and transport layer port#) for unicast.
- 2) List of FQDNs or IP addresses of the A2X Application Servers, associated with served geographical area information and list of PLMNs that the configuration applies to.
- 3) Mapping of the A2X service type to MBS session announcement for A2X message reception via MBS.
- 4) MBS session announcement for receiving A2X Application Server information via MBS (i.e. for A2X Application Server discovery using MBS).

6.2.2 A2X communication

6.2.2.1 A2X communication over PC5 reference point

6.2.2.1.1 General

A2X communication over PC5 reference point leverages V2X mechanisms to support Unicast communication mode for NR and Broadcast communication mode for both NR and LTE as defined in clause 5.2.1.1 of TS 23.287 [11] with the following applicable differences:

- V2X is replaced by A2X.
- The distinction between Vehicle UE and Pedestrian UE is not applicable to A2X.
- Groupcast mode for NR based PC5 is not supported.
- For LTE PC5 in EPS, the network scheduled operation mode (defined in referred TS 23.285 [12]) is not supported and A2X uses only the UE autonomous resources selection mode.

6.2.2.1.2 Broadcast mode communication over PC5 reference point

A2X leverages what is defined for V2X in clause 5.2.1.2 of TS 23.287 [11] with the following differences:

- V2X is replaced by A2X.
- The applicable configuration is described in clause 6.2.1.2.
- PC5 QoS parameters are described in clause 6.2.4.
- Enhanced QoS handling for NR based PC5 reference point is described in clause 6.2.4.

6.2.2.1.3 Unicast mode communication over PC5 reference point

A2X leverages what is defined for V2X in clause 5.1.1.3 of TS 23.287 [11] with the following differences:

- V2X is replaced by A2X.
- Definitions for PC5 QoS flows are described in clause 6.2.4.
- Definitions for A2X identifiers are described in clause 6.2.6.
- Procedures for Unicast mode A2X communication over PC5 reference point are described in clause 6.3.3.2.

6.2.2.1.4 IP address allocation

A2X leverages what is defined for V2X in clause 5.2.1.5 of TS 23.287 [11] with the following differences:

- V2X is replaced by A2X.
- Procedures for Unicast mode A2X communication over PC5 reference point are described in clause 6.3.3.2.

6.2.2.2 A2X communication over Uu reference point

6.2.2.2.1 A2X communication via unicast

A2X leverages what is defined for V2X in clause 5.2.2.1 of TS 23.287 [11] with the following differences:

- V2X is replaced by A2X.

6.2.2.2.2 A2X reception via MBS

A2X leverages what is defined for V2X in clause 5.2.2.2 of TS 23.287 [11] with the following differences:

- V2X is replaced by A2X.
- Multicast MBS session is not supported.
- MBS session announcement is provisioned as described in clauses 6.2.1.1 and 6.2.1.3.1.

6.2.3 A2X Application Server discovery

Procedures and mechanisms for V2X Application Server discovery used for V2X communication over Uu operation mode as specified in clause 5.3 of TS 23.287 [11] apply to A2X Application Server discovery used for A2X Broadcast MBS sessions with the following differences:

- The A2X Application Server address information as specified in clause 6.2.1.3.1 may be configured on the UE or provisioned over N1 reference point.
- V2X is replaced by A2X, e.g. V2X services to A2X services, V2X Application Server to A2X Application Server, etc.

6.2.4 QoS handling for A2X communication

6.2.4.1 QoS handling for A2X communication over PC5 reference point

A2X leverages what is defined for V2X in clauses 5.4.1 to 5.4.3 of TS 23.287 [11] with the following differences:

- V2X is replaced by A2X.
- Groupcast mode communication is not supported.
- Definitions for PC5 QoS handling are described in clause 6.2.4.
- PC5 QoS configuration parameters are described in clause 6.2.1.2.1.

- Definitions for A2X communication over PC5 Reference point are described in clause 6.2.2.1.
- Procedures for A2X unicast mode communication over PC5 Reference point are described in clause 6.3.3.2.
- Procedures for A2X Delivery of PC5 QoS parameters to NG-RAN are described in clause 6.3.5.7.
- PQI values are defined for A2X communication over PC5 reference point. The one-to-one mapping of standardized PQI values that are defined to PC5 QoS characteristics is specified in table 6.2.4.1-1.

Table 6.2.4.1-1: Standardized PQI values to QoS characteristics mapping

PQI Value	Resource Type	Default Priority Level	Packet Delay Budget	Packet Error Rate	Default Maximum Data Burst Volume	Default Averaging Window	Example Services
40	GBR (NOTE 1)	4	50 ms	10 ⁻²	N/A	2000 ms	Unicast mode Detect and Avoid with lower latency requirement
41		4	100 ms	10 ⁻²	N/A	2000 ms	Unicast mode Detect and Avoid
42		3	1000 ms	10 ⁻³	N/A	2000 ms	C2 Communication - Steer to waypoints; C2 Communication - video used to aid UAV control (VLOS)
43		3	40 ms	10 ⁻³	N/A	2000 ms	C2 Communication - Direct stick steering
44		3	140 ms	10 ⁻⁴	N/A	2000 ms	C2 Communication - video used to aid UAV control (Non-VLOS)
62		Non-GBR	4	100 ms	10 ⁻²	N/A	N/A
63	4		500 ms	10 ⁻²	N/A	N/A	Broadcast Remote ID
64	4		50 ms	10 ⁻²	N/A	N/A	Broadcast mode Detect and Avoid with lower latency requirement
65	4		100 ms	10 ⁻²	N/A	N/A	Broadcast mode Detect and Avoid

NOTE 1: GBR PQIs can only be used for unicast PC5 communications.

6.2.4.2 QoS handling for A2X communication over Uu reference point

A2X leverages what is defined for V2X in clause 5.4.5 of TS 23.287 [11] with the following differences:

- V2X is replaced by A2X.
- Notification on QoS Sustainability Analytics to the V2X Application Server is not supported in this release.
- QoS Change based on extended NG-RAN Notification to support Alternative Service Requirements is not supported in this Release.
- 5QI 75 specified in TS 23.501 [2] is intended to be also used for the delivery of A2X messages over MBS.

6.2.5 Subscription to A2X service

A2X leverages what is defined for V2X in clause 5.5 of TS 23.287 [11] with the following differences:

- V2X is replaced by A2X.
- The distinction between Vehicle and Pedestrian UE is not supported.

- Definitions for PC5 QoS parameters are described in clause 6.2.4.
- The procedure PCF based A2X Service Authorization and provisioning to UE is described in clause 6.3.2.2.

6.2.6 Identifiers

6.2.6.1 Identifiers for A2X communication over PC5 reference point

A2X leverages what is defined for V2X in clause 5.6.1 of TS 23.287 [11] with the following differences:

- V2X is replaced by A2X.
- Groupcast mode communication and corresponding identifiers are not supported.
- IP address allocation for A2X is described in clause 6.2.2.1.4.
- A2X configuration parameters are described in clause 6.2.1.2.1.
- Procedures for Unicast mode A2X communication over PC5 reference point are described in clause 6.3.3.2.

6.2.7 Interworking between EPS A2X and 5GS A2X

6.2.7.1 A2X Policy and parameter provisioning

A2X leverages what is defined for V2X in clause 5.8.1 of TS 23.287 [11] with the following differences:

- V2X is replaced by A2X.

6.2.7.2 PC5 operation

A2X leverages what is defined for V2X in clause 5.8.1 of TS 23.287 [11] with the following differences:

- V2X is replaced by A2X.

6.2.8 MBS Service Description for A2X use

The announced service information for V2X use as specified in clauses 5.10.2 and 5.10.3 of TS 23.287 [11] is used for the announced service information for A2X use with the following difference:

- V2X is replaced by A2X, e.g. V2X communication to A2X communication, V2X Application Server to A2X Application Server, etc.
- Only broadcast is used as the MBS Service Type in Table 5.10.2-1 of TS 23.287 [11].
- For MBS session announcement for A2X Application Server Discovery, the local Service Information contained in the broadcast is as described in clauses 6.2.3 and 6.3.4.1 and should include similar information defined in clause 6.2.1.3.1.

6.3 Functional description and information flows

6.3.1 Control and user plane stacks for NR PC5 reference point supporting A2X services

6.3.1.1 User plane for PC5 reference point supporting A2X services

Figure 6.3.1.1-1 depicts a user plane for NR PC5 reference point, i.e. PC5 User Plane Protocol stack.

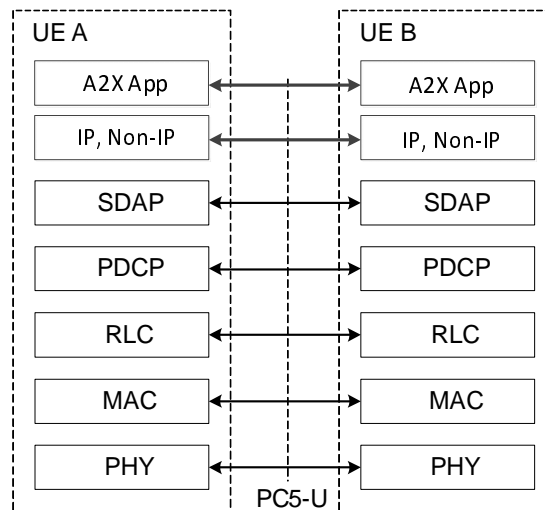
**Legend:**

- PC5-U: The SDAP/PDCP/RLC/MAC/PHY functionality is specified in TS 38.300 [15].
- For PDCP SDU type "Non-IP", a "Non-IP Type" header included in the SDU by upper layer to indicate the type of non-IP messages carried will be specified in stage 3 specification.

Figure 6.3.1.1-1: User Plane for NR PC5 reference point

IP and Non-IP PDCP SDU types are supported for the A2X communication over PC5 reference point.

For IP PDCP SDU type, only IPv6 is supported. The IP address allocation and configuration are as defined in clause 5.6.1.1 of TS 23.287 [11].

The Non-IP PDCP SDU contains a Non-IP Type header, which indicates the A2X message family used by the application layer.

NOTE: The Non-IP Type header and allowed values are defined in Stage 3.

The packets from A2X application layer are handled by the A2X layer before transmitting them to the AS layer, e.g. A2X layer maps the IP/Non IP packets to PC5 QoS Flow and marks the corresponding PFI.

6.3.1.2 Control plane for NR PC5 reference point supporting A2X services

The protocol stack of clause 6.1.2 of TS 23.287 [11] applies.

6.3.2 Procedures for A2X service authorization and provisioning to UE

6.3.2.1 General

The procedures for service authorization and provisioning to UE may be initiated by the PCF (as described in clause 6.3.2.2), by the UE (as described in clause 6.3.2.3), or by the AF (as described in clause 6.3.2.4).

6.3.2.2 PCF based A2X Service Authorization and Provisioning to UE

For PCF based Service Authorization and Provisioning to UE, the Registration procedures as defined in clause 4.2.2.2 of TS 23.502 [3], UE Policy Association Establishment procedure as defined in clause 4.16.11 of TS 23.502 [3] and UE Policy Association Modification procedure as defined in clause 4.16.12 of TS 23.502 [3] apply with the following additions:

- If the UE indicates A2X capability in the Registration Request message and if the UE is authorized to use A2X service based on subscription data, the AMF selects the PCF which supports A2X Policy/Parameter provisioning and establishes a UE policy association with the PCF for A2X Policy/Parameter delivery. PCF discovery and selection mechanism defined in clause 6.3.7.1 of TS 23.501 [2] applies and the AMF may include the A2X capability indication in the Nnrf_NFDDiscovery_Request message as the optional input parameter. If provided, the NRF takes the information into account for discovering the PCF instance.

- If the AMF receives the PC5 capability for A2X in the Registration Request message from UE, the AMF further reports the PC5 capability for A2X to the selected PCF. The PCF may determine the A2X Policy/Parameter for specific PC5 RAT based on the received UE's PC5 capability for A2X.

The PCF may update the A2X Policy/parameters to the UE in following conditions:

- UE Mobility, e.g. UE moves from one PLMN to another PLMN. This is achieved by using the procedure of UE Policy Association Modification initiated by the AMF, as defined in clause 4.16.12.1 of TS 23.502 [3].
- When there is a subscription change in the list of PLMNs where the UE is authorized to perform A2X communication over PC5 reference point. This is achieved by using UE Policy Association Modification initiated by the PCF procedure as defined in clause 4.16.12.2 of TS 23.502 [3].
- When there is a change of service specific parameter as described in clause 4.15.6.7 of TS 23.502 [3].

If the serving PLMN is removed from the list of PLMNs in the service authorization parameters, the service authorization is revoked in the UE.

When the UE is roaming, the change of subscription resulting in updates of the service authorization parameters are transferred to the UE by H-PCF via V-PCF.

The UE may perform UE triggered Policy Provisioning procedure to the PCF, after Registration procedure has been completed, as specified in clause 6.3.2.3 when the UE determines the A2X Policy/Parameter is invalid (e.g. Policy/Parameter is outdated, missing or invalid).

6.3.2.3 Procedure for UE triggered A2X Policy provisioning

The UE triggered Policy Provisioning procedure is initiated by the UE to request A2X Policy/Parameter from the PCF when UE determines the A2X Policy/Parameter is invalid in the following cases:

- if the validity timer indicated in the A2X Policy/Parameter expires;
- if there are no valid parameters, e.g. for the A2X service type a UE wants to use, for current area, or due to abnormal situation.

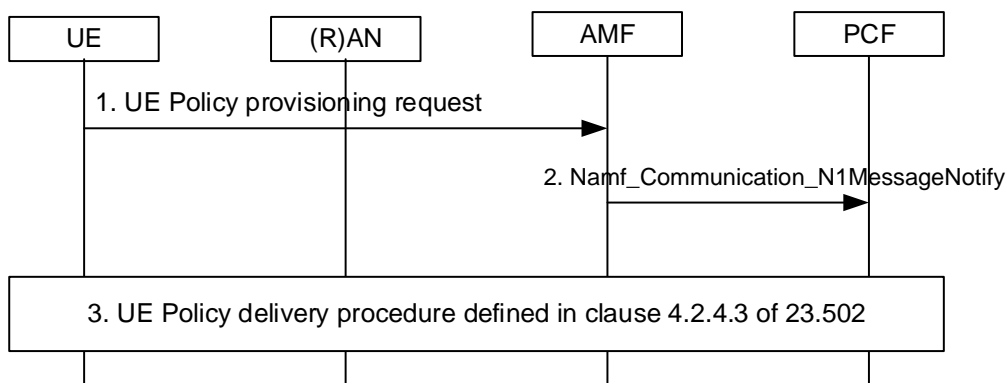

Figure 6.3.2.3-1: UE triggered A2X Policy provisioning procedure

1. The UE sends UL NAS TRANSPORT message carrying the UE Policy Container (UE A2X Policy Provisioning Request to request A2X policies) to the AMF.
2. The AMF sends the Namf_Communication_N1MessageNotify request to the PCF including the UE Policy Container received from UE.
3. The PCF receives UE Policy Container which indicates UE Policy Provisioning Request to request A2X policies. If the A2X policies are authorized based on AMF input as specified in clause 6.3.5.2 the PCF performs the UE Policy delivery procedure defined in clause 4.2.4.3 of TS 23.502 [3].

6.3.2.4 AF-based service parameter provisioning for A2X communications over control plane

The A2X Application Server can provision the 5GC with A2X service parameters via NEF using the procedure defined in clause 4.15.6.7 of TS 23.502 [3] with the following considerations:

- The AF in TS 23.502 [3] is considered as A2X Application Server in this specification.
- Service Description indicates A2X service domain information.
- Service Parameters include policy/provisioning parameters for A2X communications over PC5 and/or Uu.

NOTE: It is assumed that the A2X service domain information is set based on the Service Level Agreement with the operator.

6.3.3 Procedures for A2X communication over PC5 reference point

6.3.3.1 Broadcast mode A2X communication over NR PC5 reference point

A2X leverages what is defined for V2X in clause 6.3.1 of TS 23.287 [11] with the following differences:

- V2X is replaced by A2X.
- The applicable configuration is described in clause 6.2.1.2.
- PC5 QoS parameters are described in clause 6.2.4.
- QoS handling for NR based PC5 reference point is described in clause 6.2.4.1.
- Identifiers for A2X communication over PC5 reference points are described in clause 6.2.6.1.
- Pedestrian UE's and corresponding pedestrian UE power saving as described in clause 5.9 is not supported.

6.3.3.2 Unicast mode A2X communication over PC5 reference point

A2X leverages what is defined for V2X in clause 6.3.3 of TS 23.287 [11] with the following differences:

- V2X is replaced by A2X.
- The applicable configuration is described in clause 6.2.1.2.
- PC5 QoS parameters are described in clause 6.2.4.
- A PC5 unicast link is described in clause 6.2.2.1.3.
- IP address allocation for A2X is described in clause 6.2.2.1.4.
- Identifiers for A2X communication over PC5 reference points are described in clause 6.2.6.1.

6.3.4 Procedures for A2X communication over Uu reference point

6.3.4.1 A2X Application server discovery using broadcast MBS session

The procedure for V2X Application Server discovery using broadcast MBS session as specified in clause 6.4.2 of TS 23.287 [11] is used for A2X Application Server discovery using broadcast MBS session with the following difference:

- V2X is replaced by A2X, e.g. V2X message to A2X message, V2X Application Server to A2X Application Server, etc.

The procedure for A2X Application Server discovery using broadcast MBS session may be used by the UE only when it is configured with the information to receive A2X Application Server information via MBS as specified in clause 6.2.1.3.1.

6.3.4.2 Procedures for A2X communication with MBS

6.3.4.2.1 MBS service area mapping

Procedures and mechanisms for MBS service area mapping for V2X communication with MBS as specified in clause 6.4.3.1 of TS 23.287 [11] apply to MBS service area mapping for Broadcast Remote ID using MBS with the following differences:

- V2X is replaced by A2X, e.g. V2X services to A2X services, V2X Application Server to A2X Application Server, etc.
- V1 reference point is replaced by A2X1 reference point.

6.3.5 Procedures for Service Authorization to NG-RAN for A2X communications over PC5 reference point

Editor's note: The description related to Service Authorization to NG-RAN for A2X communications over PC5 can be updated based on RAN WG feedbacks.

6.3.5.1 General

In order to enable PC5 radio resource control in NG-RAN, per PC5 RAT A2X service authorization information and PC5 QoS parameters need to be made available in NG-RAN, this clause describes the corresponding procedures and aspects.

NOTE: LTE Uu can control LTE PC5 and/or NR PC5 resource management from the cellular network and NR Uu can control LTE PC5 and/or NR PC5 resource management from the cellular network.

6.3.5.2 Registration procedure

The Registration procedure for UE is performed as defined in TS 23.502 [3] with the following additions:

- The UE includes the PC5 Capability for A2X (i.e. LTE PC5 only, NR PC5 only, both LTE and NR PC5) as part of the "5GMM capability" in the Registration Request message. The AMF stores this information for A2X operation. The PC5 Capability for A2X indicates whether the UE is capable of A2X communication over PC5 reference point and which specific PC5 RAT(s) it supports.
- The AMF obtains the A2X Subscription data as part of the user subscription data from UDM during UE Registration procedure using Nudm_SDM service as defined in clause 4.2.2.2.2 of TS 23.502 [3].
- The AMF determines whether the UE is authorized to use A2X communication over PC5 reference point based on UE's PC5 Capability for A2X and the subscription data related to A2X service authorization information (i.e. "A2X services authorized" indication per PC5 RAT and UE-PC5-AMBR per PC5 RAT) received from UDM, and stores the A2X service authorization information as part of the UE context.
- The PCF provides the PC5 QoS parameters to AMF, and the AMF stores them in the UE context.
- If the UE is PC5 capable for A2X, and the UE is authorized to use A2X communication over PC5 reference point based on the subscription data, then the AMF shall include the following information in the NGAP message sent to NG-RAN:
 - a "A2X services authorized" indication per PC5 RAT, indicating the UE is authorized to use A2X communication over PC5 reference point.
 - UE-PC5-AMBR per PC5 RAT, used by NG-RAN for the resource management of UE's PC5 transmission for A2X services in network scheduled mode.
 - the PC5 QoS parameters used by the NG-RAN for the resource management of UE's PC5 transmission for A2X services in network scheduled mode.

- If the UE is authorized to use A2X communication over PC5 reference point, then the AMF should not initiate the release of the signalling connection after the completion of the Registration procedure. The release of the NAS signalling relies on the decision of NG-RAN, as specified in TS 23.502 [3].

6.3.5.3 Service Request procedure

The Service Request procedure for UE in CM-IDLE state is performed as defined in TS 23.502 [3] with the following additions:

- If the UE is PC5 capable for A2X, and the UE is authorized to use A2X communication over PC5 reference point, then the AMF shall include a "A2X services authorized" indication per PC5 RAT in the NGAP message.
- The AMF includes the UE-PC5-AMBR for A2X per PC5 RAT in the NGAP message to the NG-RAN as part of the UE context and NG-RAN may use in resource management of UE's PC5 transmission for A2X services in network scheduled mode.
- The AMF sends the PC5 QoS parameters for A2X to NG-RAN via N2 signalling. The PC5 QoS parameters may be stored in the UE context after the registration procedure. If the UE is authorized to use A2X communication over PC5 reference point but AMF does not have PC5 QoS parameters available, the AMF fetches the PC5 QoS parameters from the PCF.

6.3.5.4 N2 Handover procedure

The N2 based handover or the Inter-RAT to NG-RAN handover procedures for UE are performed as defined in TS 23.502 [3] with the following additions:

- If the UE is PC5 capable for A2X, and the UE is authorized to use A2X communication over PC5 reference point, then the target AMF shall send the "A2X services authorized" indication per PC5 RAT, UE-PC5-AMBR per PC5 RAT and PC5 QoS parameters to the target NG-RAN as follows:
 - For the intra AMF handover, the "A2X services authorized" indication per PC5 RAT, UE-PC5-AMBR per PC5 RAT and PC5 QoS parameters are included in the NGAP Handover Request message.
 - For the inter AMF handover or Inter-RAT handover to NG-RAN, the "A2X services authorized" indication per PC5 RAT, UE-PC5-AMBR per PC5 RAT and PC5 QoS parameters are included in the NGAP Handover Request message sent to the target NG-RAN.

6.3.5.5 Xn Handover procedure

The Xn based handover procedures for UE are performed as defined in TS 23.502 [3] with the following additions:

- If the "A2X services authorized" indication is included in the UE context (as described in TS 38.423 [16]), then the source NG-RAN shall include a "A2X services authorized" indication per PC5 RAT, UE-PC5-AMBR per PC5 RAT and PC5 QoS parameters in the XnAP Handover Request message to the target NG-RAN.
- If the UE is PC5 capable for A2X, and the UE is authorized to use A2X communication over PC5 reference point, then the AMF shall send the "A2X services authorized" indication per PC5 RAT, the UE-PC5-AMBR per PC5 RAT and PC5 QoS parameters to the target NG-RAN in the Path Switch Request Acknowledge message.

6.3.5.6 Subscriber Data Update Notification to AMF

The procedure of Subscriber Data Update Notification to AMF is performed as defined in TS 23.502 [3] with the following additions:

- The Nudm_SDM_Notification service operation may contain the "A2X services authorized" indication per PC5 RAT and/or the UE-PC5-AMBR per PC5 RAT.
- The AMF updates the UE Context with the above new A2X subscription data.
- When the AMF updates UE context stored at NG-RAN, the UE context contains the A2X subscription data.

6.3.5.7 Delivery of PC5 QoS parameters to NG-RAN

The UE Policy Association Establishment procedure and UE Policy Association Modification procedure, as defined in TS 23.502 [3], is used to provide to the AMF PC5 QoS parameters used by NG-RAN. When receiving Npcf_UEPolicyControl_Create Request from the AMF which includes the PC5 capability for A2X or when receiving the updated subscription data from UDR, the PCF generates the PC5 QoS parameters used by NG-RAN corresponding to a UE.

The (V-)PCF provides the information to the AMF as follows:

- In the roaming case, the H-PCF includes the PC5 QoS parameters used by NG-RAN in the Npcf_UEPolicyControl_Create Response message or Npcf_UEPolicyControl UpdateNotify Request message sent to V-PCF in an N2 PC5 policy container, and V-PCF relays this N2 PC5 policy container as the N2 container in the Namf_Communication_N1N2MessageTransfer message sent to AMF.
- In the non-roaming case, the PCF includes the PC5 QoS parameters used by NG-RAN in an N2 container in Namf_Communication_N1N2MessageTransfer message sent to AMF.

When the AMF determines that the N2 PC5 policy container comes from (V-)PCF, the AMF stores such information as part of the UE context.

In the UE Configuration Update procedure triggered by UE Policy Association Establishment or UE Policy Association Modification:

- The AMF forwards the PC5 QoS parameters in the NGAP message to the NG-RAN if a N2 PC5 policy container is received in the Namf_Communication_N1N2MessageTransfer message.
- The AMF forwards the PC5 QoS parameters in the NAS message to UE by using the UE Configuration Update procedure for transparent UE Policy delivery procedure defined in clause 4.2.4.3 of TS 23.502 [3] if a UE Policy Container is received in the Namf_Communication_N1N2MessageTransfer message.

NOTE 1: If the PC5 QoS parameters are provided to both NG-RAN and UE, both the N2 PC5 Policy Container and the UE Policy Container are included in the Namf_Communication_N1N2MessageTransfer message.

NOTE 2: Non-UE specific PC5 QoS parameters, e.g. default PC5 QoS parameters, can also be locally configured in NG-RAN. How such configuration is performed is out of scope of this specification.

Annex A (informative): Change history

Change history							
Date	Meeting	TDoc	CR	Rev	Cat	Subject/Comment	New version
2021-02	SA2#143-e	S2-2101029	-	-	-	TS skeleton (approved in S2-2101029)	0.0.0
2021-06	SA#92E	SP-210366	-	-	-	MCC editorial update for presentation to TSG SA#92E for information	1.0.0
2021-09	SA#92E	SP-210939	-	-	-	MCC editorial update for presentation to TSG SA#93E for approval	2.0.0
2021-09	SA#92E	-	-	-	-	MCC editorial update for publication after TSG SA#93E approval	17.0.0
2021-12	SA#94E	SP-211297	0002	2	F	Clarification and EN resolution for SMF Services	17.1.0
2021-12	SA#94E	SP-211297	0003	1	F	Clarifications for UUAA-SM procedure	17.1.0
2021-12	SA#94E	SP-211297	0004	1	F	UUAA during default PDN connection at Attach	17.1.0
2021-12	SA#94E	SP-211297	0005	-	F	USS Initiated procedures update	17.1.0
2021-12	SA#94E	SP-211297	0006	1	F	C2 Authorization for EPS	17.1.0
2021-12	SA#94E	SP-211297	0007	-	F	23.256 clean-up	17.1.0
2021-12	SA#94E	SP-211407	0008	2	F	Clean up for List of Aerial UEs in a geographic area	17.1.0
2021-12	SA#94E	SP-211297	0009	1	F	UUAA-MM Procedure Updates	17.1.0
2021-12	SA#94E	SP-211297	0010	3	F	Clarification and Correction on AF and NEF authentication service	17.1.0
2021-12	SA#94E	SP-211297	0011	2	F	Clarify the implicit subscription during the UUAA procedure	17.1.0
2021-12	SA#94E	SP-211297	0012	1	F	Clarification on UUAA-MM failure	17.1.0
2021-12	SA#94E	SP-211297	0013	1	F	Clarification on AMF and SMF addressing UAS NF/NEF	17.1.0
2021-12	SA#94E	SP-211297	0014	-	F	Correction on new CAA-level UAV ID allocation	17.1.0
2021-12	SA#94E	SP-211297	0015	1	F	Correction on UAV tracking mode	17.1.0
2021-12	SA#94E	SP-211297	0016	1	F	Association of CAA level UAV ID to 3GPP UAV ID in USS	17.1.0
2021-12	SA#94E	SP-211297	0020	1	F	Procedure for UAV replacement in EPS	17.1.0
2021-12	SA#94E	SP-211297	0022	-	F	Miscellaneous corrections	17.1.0
2021-12	SA#94E	SP-211298	0024	1	F	Correction on UUAA re-authentication and re-authorization procedure	17.1.0
2021-12	SA#94E	SP-211298	0026	1	F	Correction and simplification on UAV-C replacement procedure	17.1.0
2021-12	SA#94E	SP-211298	0028	1	F	UAS architecture figure update for IWK	17.1.0
2021-12	SA#94E	SP-211298	0030	1	F	TS 23.256: various clarifications and corrections	17.1.0
2021-12	SA#94E	SP-211298	0031	3	F	TS 23.256: Rapporteur Editorial CR	17.1.0
2021-12	SA#94E	SP-211298	0032	1	F	Correction of UUAA when aerial subscription is missing	17.1.0
2021-12	SA#94E	SP-211298	0035	1	F	Clean up for UUAA-MM procedure	17.1.0
2021-12	SA#94E	SP-211298	0036	1	F	Replace of the term pairing authorization	17.1.0
2021-12	SA#94E	SP-211298	0038	1	F	Clarifications on UUAA context during revocation procedure	17.1.0
2021-12	SA#94E	SP-211298	0039	1	F	Clarifications and corrections on UAV Re-authentication	17.1.0
2021-12	SA#94E	SP-211298	0040	1	F	Correction on UAS NF discovery and UAS NF functionality	17.1.0
2021-12	SA#94E	SP-211298	0044	-	F	Corrections on usage of Nnef_AFsessionWithQoS service for UAS	17.1.0
2022-03	SA#95E	SP-220059	0048	-	F	Clarification on cause of revocation	17.2.0
2022-03	SA#95E	SP-220059	0049	1	F	UUAA context management	17.2.0
2022-03	SA#95E	SP-220059	0051	1	F	Clarification on PDU Session Status Event	17.2.0
2022-03	SA#95E	SP-220059	0052	1	F	Clarification on UAV Re-authorization procedure	17.2.0
2022-03	SA#95E	SP-220059	0054	1	F	Revocation of C2 authorisation	17.2.0
2022-03	SA#95E	SP-220059	0055	1	F	Correction on handling the authorized CAA-Level UAV ID provided by a USS	17.2.0
2022-03	SA#95E	SP-220059	0056	1	F	Clarification on re-authorization	17.2.0
2022-03	SA#95E	SP-220059	0057	1	F	Corrections to Nnef_Authentication_AuthenticateAuthorize service operation	17.2.0
2022-06	SA#96	SP-220403	0059	1	F	Correcting errors for UAV-C address	17.3.0
2022-06	SA#96	SP-220403	0062		F	Corrections to Naf(Nnef)_Authentication_AuthenticateAuthorize service operation	17.3.0
2022-06	SA#96	SP-220403	0063	1	F	Clarification and Correction on C2 payload	17.3.0
2022-06	SA#96	SP-220403	0064	1	F	Corrections to service operation names	17.3.0
2022-09	SA#97E	SP-220782	0065	1	F	Clarifications on subscription control for UUAA-SM and C2 authorization	17.4.0
2022-09	SA#97E	SP-220782	0067		F	Correction on reference on UAV re-authentication procedure in 5GS	17.4.0
2022-12	SA#98E	SP-221075	0068	2	F	Corrections to functionality and procedure at UAS NF for C2 authorization	17.5.0
2022-12	SA#98E	SP-221075	0069	1	F	Indication of Network Assisted Positioning method for UAV positioning	17.5.0
2022-12	SA#98E	SP-221333	0072	1	F	Aerial Service Availability Update using UCU	17.5.0
2023-03	SA#99	SP-230041	0073	1	F	Addressing Editor Notes	17.6.0
2023-03	SA#99	SP-230076	0075	6	B	Support for direct C2 communication	18.0.0
2023-03	SA#99	SP-230076	0076	4	B	Architectural enhancements for Rel. 18 UAS features	18.0.0
2023-03	SA#99	SP-230076	0077	1	B	Architectural enhancements for support of Broadcast Remote ID	18.0.0
2023-03	SA#99	SP-230076	0078	3	B	Architectural enhancements for support of Detect And Avoid	18.0.0
2023-03	SA#99	SP-230076	0079	1	B	Ground based DAA for an area (Sol#7)	18.0.0
2023-03	SA#99	SP-230076	0081	2	B	Additional architectural enhancements for Rel. 18 UAS features	18.0.0
2023-03	SA#99	SP-230076	0082	1	F	Clarification on ProSe capability support for UAV UEs	18.0.0
2023-06	SA#100	SP-230494	0084	1	F	Corrections to Direct C2 authorization via UUAA procedure	18.1.0

2023-06	SA#100	SP-230494	0085	5	F	Direct C2 authorization exceptions	18.1.0
2023-06	SA#100	SP-230494	0086	1	F	Clarification of EN on inter-PLMN A2X	18.1.0
2023-06	SA#100	SP-230494	0087	1	F	Corrections to authorization of A2X	18.1.0
2023-06	SA#100	SP-230494	0088	-	F	Clarification on differences when referring to TS 23.287	18.1.0
2023-06	SA#100	SP-230494	0090	-	F	Clarification on general concept related to PC5 based functionalities	18.1.0
2023-06	SA#100	SP-230494	0091	-	F	Clarification on A2X Communication modes	18.1.0
2023-06	SA#100	SP-230494	0092	-	F	Clarification on A2X Policy	18.1.0
2023-06	SA#100	SP-230494	0094	1	F	Removal of cross-rat authorization	18.1.0
2023-06	SA#100	SP-230494	0095	-	C	Removal of UE requesting UE policies from PCF in REGISTRATION REQUEST	18.1.0
2023-06	SA#100	SP-230494	0097	1	C	Ground-based DAA for an area enhancements	18.1.0
2023-06	SA#100	SP-230494	0098	3	B	N2 and Xn based HO for UAV	18.1.0
2023-06	SA#100	SP-230494	0100	2	F	Clarification of support of A2X capability of UAV UE	18.1.0
2023-06	SA#100	SP-230494	0102	1	F	Correction to Abbreviation for A2X and A2X definition	18.1.0
2023-06	SA#100	SP-230494	0089	1	B	MBS support for Broadcast Remote ID	18.1.0
2023-06	SA#100	SP-230494	0103	2	F	Restructuring to clarify A2X Service	18.1.0
2023-12	SA#102	SP-231274	0108	-	F	Fixing reference towards UUAA-SM procedure for Direct C2	18.2.0
2023-12	SA#102	SP-231274	0109	1	F	New PQI values for A2X communication over PC5 reference point	18.2.0
2023-12	SA#102	SP-231274	0110	-	F	Clarification on A2X communication over MBS	18.2.0
2023-12	SA#102	SP-231274	0111	2	F	Clarifying separation between Common A2X and A2X Service specific descriptions	18.2.0
2023-12	SA#102	SP-231244	0113	-	A	Cleanup of UUAA-MM and UUAA-SM relation	18.2.0
2023-12	SA#102	SP-231274	0114	1	F	Correction for UAS_Ph2	18.2.0
2023-12	SA#102	SP-231274	0115	1	F	Correction to authorization for Direct C2 communication	18.2.0
2023-12	SA#102	SP-231274	0116	1	F	Clarification on use of A2X Application Layer ID for Direct DAA	18.2.0
2023-12	SA#102	SP-231274	0117	1	F	Reference correction in UUAA Revocation	18.2.0
2023-12	SA#102	SP-231274	0118	1	F	Minor clarification in USS Discovery	18.2.0

History

Document history		
V18.2.0	May 2024	Publication