

ETSI TS 124 523 V18.0.0 (2024-05)



**Universal Mobile Telecommunications System (UMTS);
LTE;
Core and enterprise Next Generation Network (NGN)
interaction scenarios;
Architecture and functional description
(3GPP TS 24.523 version 18.0.0 Release 18)**



Reference

RTS/TSGC-0124523vi00

Keywords

LTE,UMTS

ETSI

650 Route des Lucioles
F-06921 Sophia Antipolis Cedex - FRANCE

Tel.: +33 4 92 94 42 00 Fax: +33 4 93 65 47 16

Siret N° 348 623 562 00017 - APE 7112B
Association à but non lucratif enregistrée à la
Sous-Préfecture de Grasse (06) N° w061004871

Important notice

The present document can be downloaded from:

<https://www.etsi.org/standards-search>

The present document may be made available in electronic versions and/or in print. The content of any electronic and/or print versions of the present document shall not be modified without the prior written authorization of ETSI. In case of any existing or perceived difference in contents between such versions and/or in print, the prevailing version of an ETSI deliverable is the one made publicly available in PDF format at www.etsi.org/deliver.

Users of the present document should be aware that the document may be subject to revision or change of status.

Information on the current status of this and other ETSI documents is available at

<https://portal.etsi.org/TB/ETSIDeliverableStatus.aspx>

If you find errors in the present document, please send your comment to one of the following services:

<https://portal.etsi.org/People/CommitteeSupportStaff.aspx>

If you find a security vulnerability in the present document, please report it through our
Coordinated Vulnerability Disclosure Program:

<https://www.etsi.org/standards/coordinated-vulnerability-disclosure>

Notice of disclaimer & limitation of liability

The information provided in the present deliverable is directed solely to professionals who have the appropriate degree of experience to understand and interpret its content in accordance with generally accepted engineering or other professional standard and applicable regulations.

No recommendation as to products and services or vendors is made or should be implied.

No representation or warranty is made that this deliverable is technically accurate or sufficient or conforms to any law and/or governmental rule and/or regulation and further, no representation or warranty is made of merchantability or fitness for any particular purpose or against infringement of intellectual property rights.

In no event shall ETSI be held liable for loss of profits or any other incidental or consequential damages.

Any software contained in this deliverable is provided "AS IS" with no warranties, express or implied, including but not limited to, the warranties of merchantability, fitness for a particular purpose and non-infringement of intellectual property rights and ETSI shall not be held liable in any event for any damages whatsoever (including, without limitation, damages for loss of profits, business interruption, loss of information, or any other pecuniary loss) arising out of or related to the use of or inability to use the software.

Copyright Notification

No part may be reproduced or utilized in any form or by any means, electronic or mechanical, including photocopying and microfilm except as authorized by written permission of ETSI.

The content of the PDF version shall not be modified without the written authorization of ETSI.

The copyright and the foregoing restriction extend to reproduction in all media.

© ETSI 2024.
All rights reserved.

Intellectual Property Rights

Essential patents

IPRs essential or potentially essential to normative deliverables may have been declared to ETSI. The declarations pertaining to these essential IPRs, if any, are publicly available for **ETSI members and non-members**, and can be found in ETSI SR 000 314: "*Intellectual Property Rights (IPRs); Essential, or potentially Essential, IPRs notified to ETSI in respect of ETSI standards*", which is available from the ETSI Secretariat. Latest updates are available on the ETSI Web server (<https://ipr.etsi.org/>).

Pursuant to the ETSI Directives including the ETSI IPR Policy, no investigation regarding the essentiality of IPRs, including IPR searches, has been carried out by ETSI. No guarantee can be given as to the existence of other IPRs not referenced in ETSI SR 000 314 (or the updates on the ETSI Web server) which are, or may be, or may become, essential to the present document.

Trademarks

The present document may include trademarks and/or tradenames which are asserted and/or registered by their owners. ETSI claims no ownership of these except for any which are indicated as being the property of ETSI, and conveys no right to use or reproduce any trademark and/or tradename. Mention of those trademarks in the present document does not constitute an endorsement by ETSI of products, services or organizations associated with those trademarks.

DECT™, **PLUGTESTS™**, **UMTS™** and the ETSI logo are trademarks of ETSI registered for the benefit of its Members. **3GPP™** and **LTE™** are trademarks of ETSI registered for the benefit of its Members and of the 3GPP Organizational Partners. **oneM2M™** logo is a trademark of ETSI registered for the benefit of its Members and of the oneM2M Partners. **GSM®** and the GSM logo are trademarks registered and owned by the GSM Association.

Legal Notice

This Technical Specification (TS) has been produced by ETSI 3rd Generation Partnership Project (3GPP).

The present document may refer to technical specifications or reports using their 3GPP identities. These shall be interpreted as being references to the corresponding ETSI deliverables.

The cross reference between 3GPP and ETSI identities can be found under <https://webapp.etsi.org/key/queryform.asp>.

Modal verbs terminology

In the present document "**shall**", "**shall not**", "**should**", "**should not**", "**may**", "**need not**", "**will**", "**will not**", "**can**" and "**cannot**" are to be interpreted as described in clause 3.2 of the [ETSI Drafting Rules](#) (Verbal forms for the expression of provisions).

"**must**" and "**must not**" are **NOT** allowed in ETSI deliverables except when used in direct citation.

Contents

Intellectual Property Rights	2
Legal Notice	2
Modal verbs terminology.....	2
Foreword.....	5
1 Scope	6
2 References	6
3 Definitions, symbols and abbreviations	7
3.1 Definitions	7
3.2 Abbreviations	7
4 Introduction	8
4.1 General modelling and relationship to NGN releases	8
4.2 Levels of service provision.....	8
4.3 Introduction to the scenarios covered by the present document.....	9
5 General requirements	9
6 Scenarios relating to a level of service of IP connectivity	9
6.1 Scenario 1: IP VPN providing a virtual leased line between NGCN sites	9
6.1.1 Introduction.....	9
6.1.2 Involved functional entities – originating	10
6.1.3 Involved functional entities - terminating	10
6.1.4 Interoperability with other scenarios	10
6.1.5 Emergency calls.....	10
6.1.6 Configuration / provisioning issues	11
6.1.7 Security issues	11
6.1.8 Charging issues	11
6.1.9 Transport control issues	11
6.2 Scenario 2: IP VPN tunnel providing a virtual leased line between a remote terminal and an NGCN sites.....	11
6.2.1 Introduction.....	11
6.2.2 Involved functional entities – originating	11
6.2.3 Involved functional entities - terminating	12
6.2.4 Interoperability with other scenarios	12
6.2.5 Emergency calls.....	12
6.2.6 Configuration / provisioning issues	12
6.2.7 Security issues	13
6.2.8 Charging issues	13
6.2.9 Transport control issues	13
7 Scenarios relating to a level of service of session establishment and control of communication session	13
7.1 Scenario 3: Session level virtual leased line.....	13
7.1.1 Introduction.....	13
7.1.2 Involved functional entities – originating	14
7.1.3 Involved functional entities - terminating	15
7.1.4 Interoperability with other scenarios	15
7.1.5 Emergency calls.....	15
7.1.6 Configuration / provisioning issues	15
7.1.7 Security issues	16
7.1.8 Charging issues	16
7.1.9 Transport control issues	16
8 Scenarios relating to a level of service of application level	16
8.1 General	16
8.2 Scenario 4: Hosted Enterprise Services (HES).....	16
8.2.1 Introduction.....	16

8.2.2	Involved functional entities – originating	17
8.2.3	Involved functional entities - terminating	18
8.2.4	Interoperability with other scenarios	19
8.2.5	Emergency calls	19
8.2.6	Configuration / provisioning issues	19
8.2.7	Security issues	19
8.2.8	Charging issues	19
8.2.9	Transport control issues	19
8.3	Scenario 5: Business trunking (subscription based)	20
8.3.1	Introduction.....	20
8.3.2	Involved functional entities – originating	20
8.3.3	Involved functional entities - terminating	21
8.3.4	Interoperability with other scenarios	21
8.3.5	Emergency calls.....	21
8.3.6	Configuration / provisioning issues	22
8.3.7	Security issues	22
8.3.8	Charging issues	22
8.3.9	Transport control issues	22
8.4	Scenario 6: Business trunking (peering based).....	22
8.4.1	Introduction.....	22
8.4.2	Involved functional entities – originating	23
8.4.3	Involved functional entities - terminating	24
8.4.4	Interoperability with other scenarios	24
8.4.5	Emergency calls.....	24
8.4.6	Configuration / provisioning issues	25
8.4.7	Security issues	25
8.4.8	Charging issues	25
8.4.9	Transport control issues	25
9	Scenarios relating to roaming.....	25
9.1	Scenario 7: NGCN user roaming into NGN public network	25
9.1.1	Introduction.....	25
9.1.2	Involved functional entities.....	26
9.1.3	Void	27
9.1.4	Interoperability with other scenarios	27
9.1.5	Emergency calls.....	27
9.1.6	Configuration / provisioning issues	27
9.1.7	Security issues	27
9.1.8	Charging issues	27
9.1.9	Transport control issues	27
9.2	Scenario 8: NGCN user roaming into another NGCN site of the same enterprise	27
9.2.1	Introduction.....	27
9.3	Scenario 9: HES user roams into NGCN site of the same enterprise	28
9.3.1	Introduction.....	28
9.4	Scenario 10: HES user roams into another NGN	28
9.4.1	Introduction.....	28
9.5	Scenario 11: NGN public network user roaming into NGCN	28
9.5.1	Introduction.....	28
9.6	Scenario 12: NGCN user roaming into an NGCN of a different enterprise	28
9.6.1	Introduction.....	28
Annex A (informative):	Change history	29
History		30

Foreword

This Technical Specification has been produced by the 3rd Generation Partnership Project (3GPP).

The contents of the present document are subject to continuing work within the TSG and may change following formal TSG approval. Should the TSG modify the contents of the present document, it will be re-released by the TSG with an identifying change of release date and an increase in version number as follows:

Version x.y.z

where:

- x the first digit:
 - 1 presented to TSG for information;
 - 2 presented to TSG for approval;
 - 3 or greater indicates TSG approved document under change control.
- y the second digit is incremented for all changes of substance, i.e. technical enhancements, corrections, updates, etc.
- z the third digit is incremented when editorial only changes have been incorporated in the document.

1 Scope

The present document provides the possible scenarios for:

- the interconnection of an Next Generation Corporate Network (NGCN) with a Next Generation Network (NGN); and
- the support of NGCN capabilities within an NGN, either towards a User Equipment (UE) or to an NGCN.

Unless otherwise specified by reference to other documents, all requirements relating to architecture and functional requirements are contained within the present document.

2 References

The following documents contain provisions which, through reference in this text, constitute provisions of the present document.

- References are either specific (identified by date of publication, edition number, version number, etc.) or non-specific.
- For a specific reference, subsequent revisions do not apply.
- For a non-specific reference, the latest version applies. In the case of a reference to a 3GPP document (including a GSM document), a non-specific reference implicitly refers to the latest version of that document *in the same Release as the present document*.

- [1] 3GPP TS 23.167: "Technical Specification Group Services and System Aspects; IP Multimedia Subsystem (IMS) emergency sessions".
- [2] 3GPP TS 22.519: "Technical Specification Group Services and System Aspects; Business Communication Requirements".
- [3] ETSI ES 282 001 (V.3.4.1): "Telecommunications and Internet converged Services and Protocols for Advanced Networking (TISPAN); NGN Functional Architecture".
- [4] 3GPP TS 24.524: "Technical Specification Group Core Network and Terminals; Hosted Enterprise Services; Architecture, functional description and signalling".
- [5] 3GPP TS 24.525: "Technical Specification Group Core Network and Terminals; Business trunking; Architecture and functional description".
- [6] 3GPP TS 29.162: "Technical Specification Group Core Network and Terminals; Interworking between IM CN subsystem and IP networks".
- [7] 3GPP TS 33.203: "Technical Specification Group Services and System Aspects; 3G Security; Access security for IP-based services".
- [8] ETSI TR 102 478 (V1.1.1): "Enterprise Communication in Next Generation Corporate Networks (NGCN) involving Public Next Generation Networks (NGN)" (also published as ECMA TR/91).
- [9] IETF RFC 5863 (April 2010): "Requirements from Session Initiation Protocol (SIP) Session Border Control (SBC) Deployments".
- [10] 3GPP TS 33.210: "Technical Specification Group Services and System Aspects; 3G security; Network Domain Security (NDS); IP network layer security".
- [11] 3GPP TS 23.218: "Technical Specification Group Core Network and Terminals; IP Multimedia (IM) session handling; IM call model; Stage 2".

3 Definitions, symbols and abbreviations

3.1 Definitions

For the purpose of the present document, the terms and definitions given in 3GPP TS 22.519 [2] apply:

business trunking
 business trunking application
 Corporate telecommunication Network (CN)
 Hosted Enterprise Services (HES)
 Next Generation CN (NGCN)
 NGCN site
 PNP number
 private network traffic
 Private Numbering Plan (PNP)
 public network traffic

3.2 Abbreviations

For the purposes of the present document, the following abbreviations apply:

API	Application Programming Interface
AS	Application Server
ASP	Application Service Provider
BGCF	Breakout Gateway Control Function
CN	Core Network
CND	Customer Network Device
CNG	Customer Network Gateway
DHCP	Dynamic Host Configuration Protocol
FQDN	Fully Qualified Domain Name
HES	Hosted Enterprise Services
HSS	Home Subscriber Server
IBCF	Interconnection Border Control Function
I-CSCF	Interrogating CSCF
IM	IP Multimedia
IMCN	IP Multimedia Core Network
IMS	IP Multimedia Subsystem
IOI	Inter Operator Identifier
IP	Internet Protocol
IWF	InterWorking Function
MACF	Multiple Association Control Function
NASS	Network Attachment SubSystem
NAT	Network Address Translator
NGCN	Next Generation Corporate Network
NGN	Next Generation Network
P-CSCF	Proxy CSCF
PNP	Private Numbering Plan
PSAP	Public Safety Answering Point
RACS	Resource and Admission Control Subsystem
S-CSCF	Serving CSCF
SIP	Session Initiation Protocol
SSP	Session Service Provider
TE	Terminal Equipment
TSP	Transport Service Provider
UE	User Equipment
URI	Uniform Resource Identifier

4 Introduction

4.1 General modelling and relationship to NGN releases

A number of different scenarios will likely exist for enabling interactions between Next-Generation Corporate Networks (NGCN) and Next Generation (public) Networks (NGN). The present document describes a sub-set of these scenarios and the architectural and functional requirements that arise from the support of these scenarios. Future releases may document other scenarios as requirements emerge.

4.2 Levels of service provision

The development of different interaction scenarios based upon the distribution of the hosting of private network capabilities in the enterprise operator and/or in the public NGN operator leads to the concept of the public NGN operator being able to offer services to NGCNs and the NGCN users at a number of different levels. This concept is further described in ETSI TR 102 478 [8].

The most basic level of service provision is IP connectivity. Differentiation from the Internet can be in the form of improved or guaranteed quality of service or security. For the purposes of the present document an NGN that provides this level of service acts as a Transport Service Provider (TSP).

A second level of service provision is in session establishment and control of communication sessions, e.g. voice, multimedia, messaging. Here the NGN adds value by being involved in the signalling protocol used to establish and control media sessions. For the purposes of the present document the primary session control signalling protocol concerned is assumed to be the Session Initiation Protocol (SIP). Added value can include intelligent routing, provision of quality of service for media, provision of gateway services to legacy networks, assistance in NAT traversal, etc. For the purposes of the present document an NGN that provides this level of service is known as a Session Service Provider (SSP).

A third level of service provision is at the application level. Applications can be many and varied, but for the purposes of the present document an application is assumed to be applied on top of session level services. An application may be able to monitor or control multi-media sessions (either directly or through a protocol or API) and may or may not be involved in media as well. Examples of applications that involve media include conferencing services, transcoding and translation services and call distribution centres. Examples of applications that monitor or control sessions but do not involve media include presence services, call logging services and UA configuration services. In addition, an application may be accessed through a session control protocol such as SIP. For the purposes of the present document an NGN that provides this level of service is known as an Application Service Provider (ASP).

NOTE 1: An NGN acting as an ASP is not necessarily providing these capabilities on an IMS application server, it is providing any level of functionality above that of an SSP at any appropriate entity.

At the application level, the additional services can be provided by the home network operator, or can be provided by a third party service provider. It is also possible that the enterprise itself provides the services, by providing equipment that acts as an application server beyond an ISC gateway function.

An NGN may provide services at one or more of these levels. Not all services offered will be of interest to enterprise customers and of relevance for interworking with NGCNs. Enterprise customers may use different NGNs for different levels of service provision and may have different contractual relationships with each of these NGNs. In addition, for a given communication and depending on the number of parties to be interconnected and/or the number of services to be accessed, multiple providers may be involved.

NOTE 2: Similarly an NGCN can provide services at these three levels to enterprise users. In particular, services at the session establishment and control level and/or application level can be provided by an NGCN site to enterprise users on other NGCN sites or supported by hosted enterprise services.

The scenarios provided in the present document are presented in accordance with this concept.

4.3 Introduction to the scenarios covered by the present document

The present document has been structured following the service level categories as introduced in subclause 4.2 in mind, as follows:

- clause 6 presents scenarios that relate to provision of IP connectivity level services offered by an NGN;
- clause 7 presents scenarios that relate to provision of session establishment and control of communication session services offered by an NGN;
- clause 8 presents scenarios that relate to provision of application level services offered by an NGN; and
- clause 9 presents scenarios that relate to provision of session level roaming services offered by an NGN.

The scenarios presented in clause 6 are IP level virtual leased line services between NGCN sites or between an NGCN site and a remote NGCN UE.

The scenario presented in clause 7 is a session level virtual leased line.

The application level service scenarios presented in clause 8 are hosted enterprise services (HES), subscription based business trunking and peering based business trunking.

Clause 9 presents a special class of session level service scenarios that are so distinct from other session level services that they are a service class of their own. Roaming scenario covered in this release is the ability for an NGCN user to be able to roam into an NGN with which the NGCN has a roaming agreement. Other scenarios are listed for completeness, however these scenarios are not in the scope of the current release or are already covered as part of normal roaming procedures.

5 General requirements

No additional general requirements are identified in the present document for this release.

6 Scenarios relating to a level of service of IP connectivity

6.1 Scenario 1: IP VPN providing a virtual leased line between NGCN sites

6.1.1 Introduction

This scenario describes the provision of capabilities of the NGN to provide a IP VPN providing a virtual leased line between two NGCN sites. The NGN provides no other functionality.

6.1.2 Involved functional entities – originating

Figure 6.1.1 shows the functional entities involved in the originating scenario in support of IP VPN interconnection.

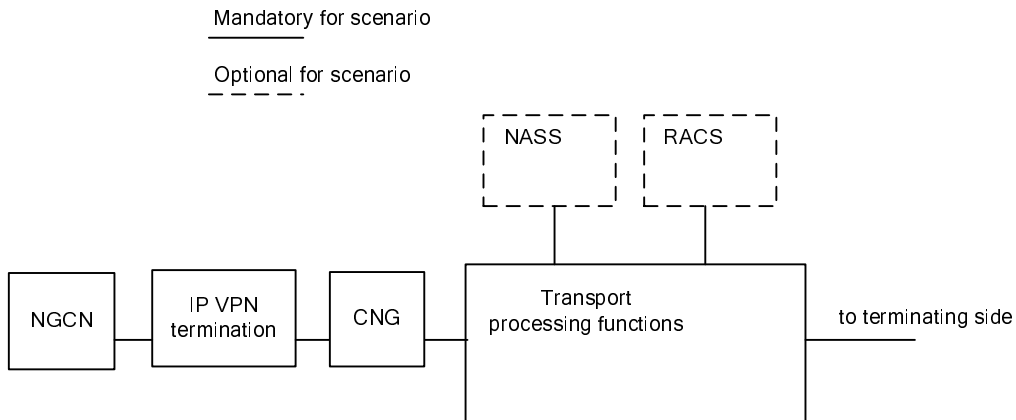

Figure 6.1.1: Originating scenario for IP VPN interconnection

6.1.3 Involved functional entities - terminating

Figure 6.1.2 shows the functional entities involved in the terminating scenario in support of IP VPN interconnection.

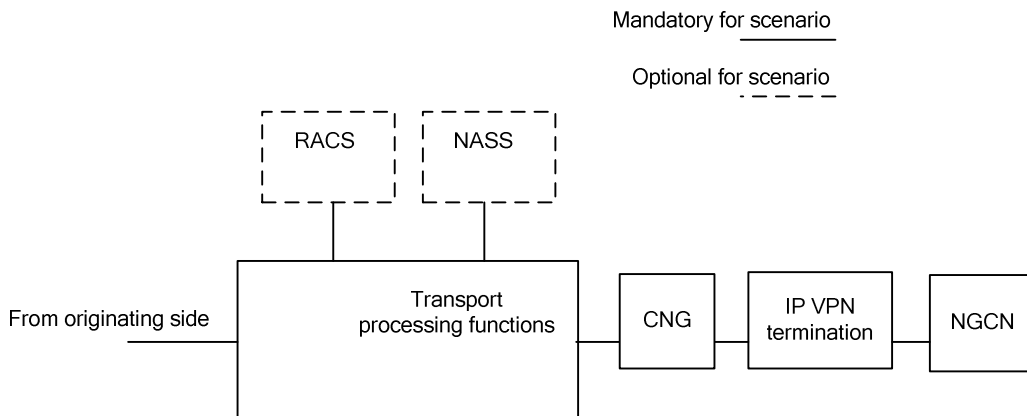

Figure 6.1.2: Terminating scenario for IP VPN interconnection

6.1.4 Interoperability with other scenarios

Subclauses 6.1.2 and 6.1.3 can be combined together to provide an NGN transit scenario.

Subclause 6.1.2 is also intended to interoperate with subclause 6.2.3, and subclause 6.1.3 to interoperate with subclause 6.2.2, in order to allow similar functionality allowing a remote terminal to access an NGCN site.

Interoperability with other business communication scenarios is not possible.

NOTE: Interconnection with other scenarios is not possible, because there is no IP VPN termination in the NGN to support interworking the IP VPN.

6.1.5 Emergency calls

In this scenario, emergency calls have to be supported entirely within the NGCN, and some other scenario provided for delivery to the NGN if required.

6.1.6 Configuration / provisioning issues

The IP level communication between the two NGCNs can be provided using a number of mechanisms. The simplest mechanism is to configure peer IP addresses or FQDNs, and appropriate credentials for the security mechanism in use, in the IP VPN termination. The configuration of this information is outside the scope of the present document.

There are no configuration requirements for supporting this scenario in the NGN.

6.1.7 Security issues

Security is provided by appropriate security mechanism between the IP VPN endpoints, e.g. IPsec or TLS. Whether the NGN provides security mechanisms depends on the service level agreements.

6.1.8 Charging issues

Not applicable.

6.1.9 Transport control issues

The NGCN site interfaces to the NGN using an IP VPN termination and the CNG which can both be an integral part of the NGCN equipment.

NASS can be used, e.g. to support the allocation of a IP address to the CNG, and the authentication of the CNG as an endpoint.

RACS can be used by the NGN to control enforcement of policies within the transport layer. These policies are pushed to the RACS by the NASS each time the CNG attaches to the NGN.

NOTE: The RACS could have similar functionality to the above based on receipt of the policies from the management plane.

6.2 Scenario 2: IP VPN tunnel providing a virtual leased line between a remote terminal and an NGCN sites

6.2.1 Introduction

This scenario describes the provision of capabilities of the NGN to provide a IP VPN tunnel providing a virtual leased line between a remote terminal and an NGCN site. The NGN provides no other functionality.

6.2.2 Involved functional entities – originating

Figure 6.2.1 shows the functional entities involved in the originating scenario in support of IP VPN interconnection.

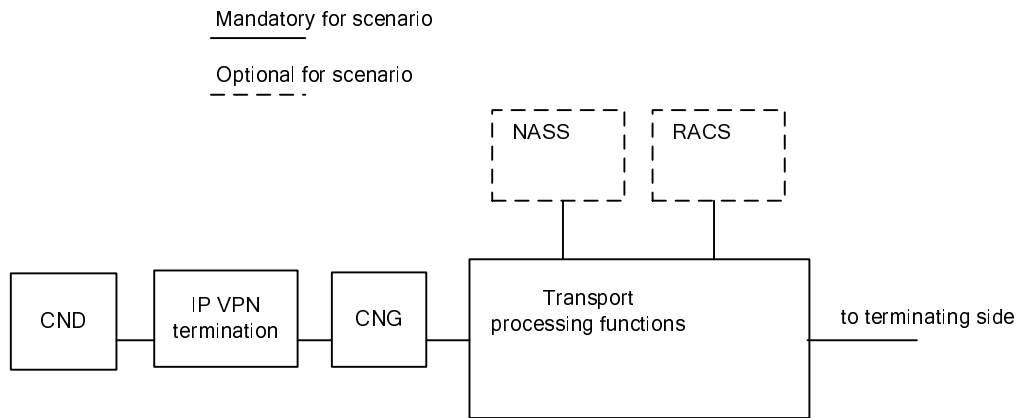

Figure 6.2.1: Originating scenario for IP VPN interconnection

6.2.3 Involved functional entities - terminating

Figure 6.2.2 shows the functional entities involved in the terminating scenario in support of IP VPN interconnection.

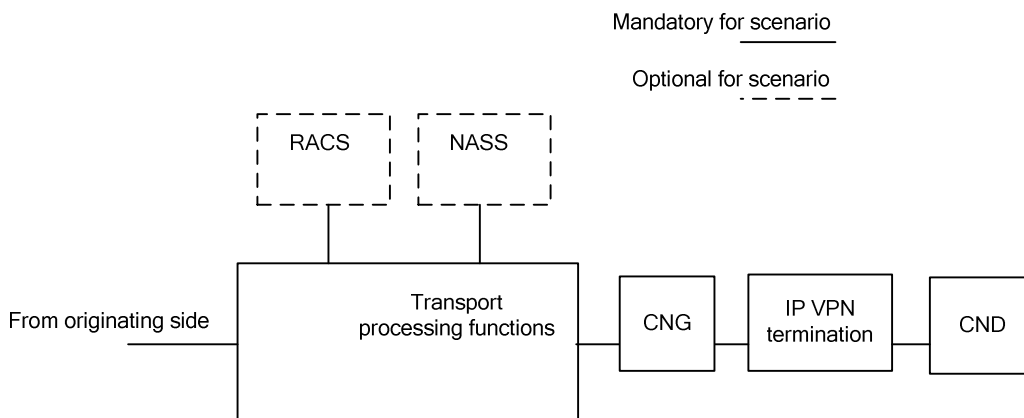

Figure 6.2.2: Terminating scenario for IP VPN interconnection

6.2.4 Interoperability with other scenarios

Subclauses 6.2.2 and 6.2.3 can be used in conjunction with the IP VPN tunnel providing a virtual leased line to an NGCN to provide interoperability. Thus subclause 6.1.2 is also intended to interoperate with subclause 6.2.3, and subclause 6.1.3 to interoperate with subclause 6.2.2.

Interoperability with other business communication scenarios is not possible.

NOTE: Interconnection with other scenarios is not possible, because there is no IPsec IP VPN termination in the NGN to support interworking the IP VPN tunnel.

6.2.5 Emergency calls

In this scenario, emergency calls have to be supported entirely within the NGCN, and some other scenario provided for delivery to the NGN if required.

6.2.6 Configuration / provisioning issues

The IP level communication between the TE CNG and the NGCN can be provided using a number of mechanisms. The simplest mechanism is to configure peer IP addresses or FQDNs, and appropriate credentials for the security

mechanism in use, in the IPsec terminations IP VPN termination. The configuration of this information is outside the scope of the present document.

There are no configuration requirements for supporting this scenario in the NGN.

6.2.7 Security issues

Security is provided by appropriate security mechanism between the IP VPN endpoints, e.g. use of IPsec or TLS. The NGN provides no security mechanisms.

6.2.8 Charging issues

Not applicable.

6.2.9 Transport control issues

The TE CND interfaces to the NGN using an IPsec IP VPN termination and the CNG.

NASS can be used, e.g. to support the allocation of a IP address to the CNG, and the authentication of the CNG as an endpoint.

RACS can be used by the NGN to control enforcement of policies within the transport layer. These policies are pushed to the RACS by the NASS at each time the CNG attaches to the NGN.

NOTE: The RACS could have similar functionality to the above based on receipt of the policies from the management plane.

There is no support by functionality in the NASS and RACS.

7 Scenarios relating to a level of service of session establishment and control of communication session

7.1 Scenario 3: Session level virtual leased line

7.1.1 Introduction

This scenario describes the provision of capabilities of the NGN to support an IP multimedia virtual leased service for the NGCN equivalent to a leased-line scenario but between multiple NGCN sites of a single NGCN. This scenario involves primarily the routing capabilities of the IM CN subsystem within the NGN. The NGCN interfaces to the NGN using SIP as the control protocol. The same NGCN exists at both the originating side and at the terminating side. Break-in and break-out traffic is not applicable with this scenario.

As this scenario is equivalent to the leased line scenario, the routing is fixed, i.e. a request at a specific entry point will always be directed to the same exit point of an NGN, the exit point maybe on the boundary between an originating and a terminating NGN hosting session level business communication capabilities or between a terminating NGN and a connected NGCN site. Scenario 6 provides a similar architecture where intelligent capabilities are supported.

7.1.2 Involved functional entities – originating

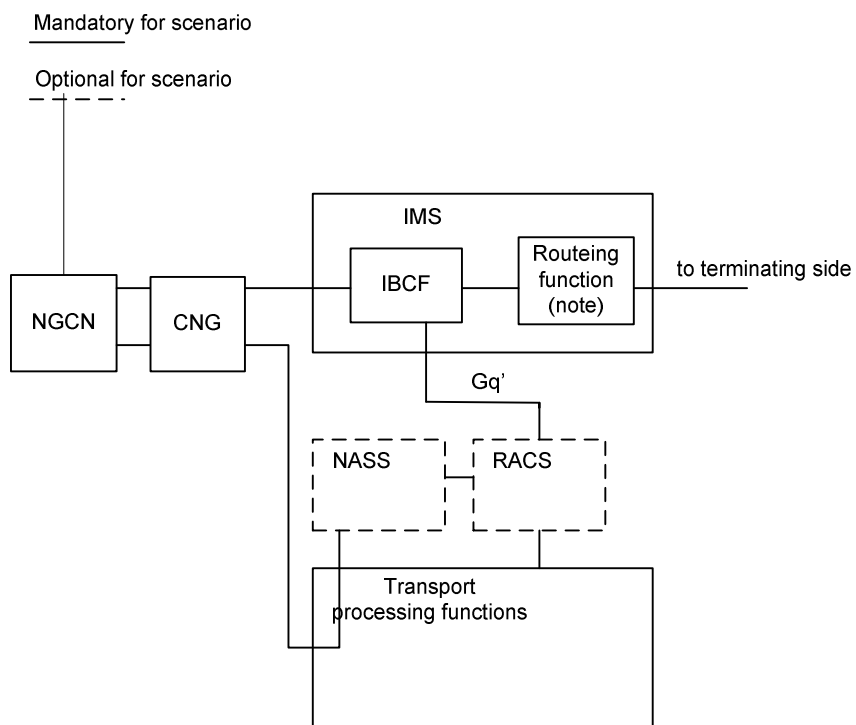

NOTE: One or more routeing functions can appear in the originating side for this scenario.

Figure 7.1.1: Session level virtual leased line scenario originating functional entities

In this particular scenario the IBCF will route based on information about the entry point, not based on the destination of a request.

7.1.3 Involved functional entities - terminating

Mandatory for scenario

Optional for scenario

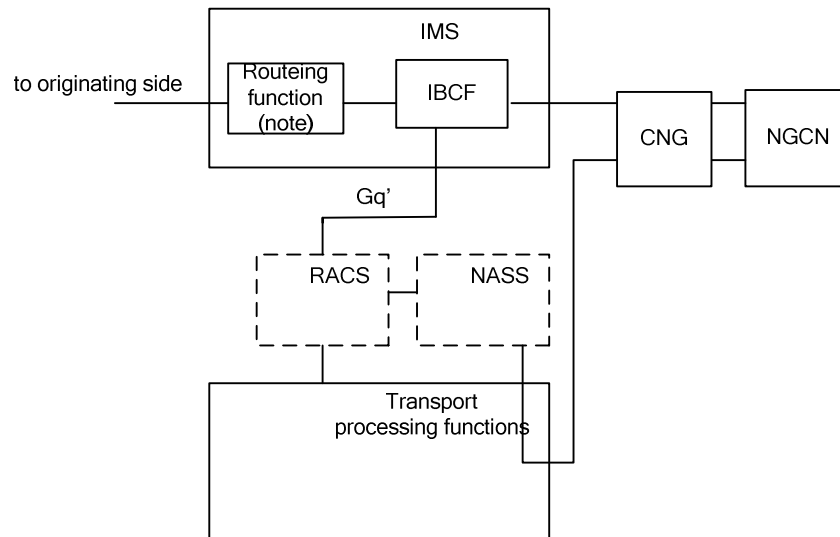

NOTE: One or more routeing functions can appear in the terminating side for this scenario.

Figure 7.1.2: Session level virtual leased line scenario terminating functional entities

In this scenario the exit point determined by the originating virtual leased line scenario is the IBCF connecting an NGCN site.

7.1.4 Interoperability with other scenarios

The originating side session level virtual leased line scenario can interoperate with any other terminating scenario where the traffic relates to dialogs or transactions belonging within the enterprise network, e.g. the scenarios for hosted enterprise services.

The terminating side session level virtual leased line scenario can interoperate with any other originating scenario where the traffic relates to dialogs or transactions belonging within the enterprise network, e.g. the scenarios for hosted enterprise services.

NOTE: The functionality provided by the routeing function is that of a SIP proxy, and the functionality provided by the IBCF is that of a session border controller, so interoperability can be provided with existing solutions not based on IMS. In this case, the procedures of 3GPP TS 29.162 [6] will apply at the interworking point. The possible functionalities of a session border controller are described in IETF RFC 5863 [9]. Such interworking may be limited by the SIP extensions that are supported across the interface. ETSI ES 282 001 [3] provides for an IWF which may also provide some appropriate functionality in this respect.

7.1.5 Emergency calls

There is no direct support NGN emergency calls within this scenario, although NGCN emergency calls may be supported. Another scenario has to be used by the enterprise network provider to support NGN emergency calls to or from the enterprise network.

7.1.6 Configuration / provisioning issues

The IBCF need to be configured to route requests coming in over a specific entry point to a specific exit point.

7.1.7 Security issues

3GPP TS 33.210 [10] shall apply to the interconnection between the NGCN and the NGN.

7.1.8 Charging issues

Inter Operator Identifiers (IOI) shall be exchanged between the NGCN and the NGN.

NOTE: IOI usage is not fully defined for enterprise communication in this release.

7.1.9 Transport control issues

NOTE: Definition of the transport control issues in this scenario is outside the scope of this release of the present document.

8 Scenarios relating to a level of service of application level

8.1 General

For each of the scenarios presented in this clause, it is possible for the NGN to provide services either at the session establishment and control level or at the application level, as described in subclause 4.2. Some of the functional entity diagrams show the involvement of an AS. Where an AS is shown, this does not necessarily constitute provision of services at the application level, as described in subclause 4.1. It is possible to deploy an AS for realizing services at the session establishment and control level.

NOTE: Corporate networks can be connected in different arrangements. One is connecting them over an interface to a P-CSCF (subscription-based arrangement), the other is when it is connected over an interface to an IBCF (peering-based arrangement).

8.2 Scenario 4: Hosted Enterprise Services (HES)

8.2.1 Introduction

This scenario describes the provision of capabilities of the NGN to support end users directly attached to the NGN with services belonging to the enterprise network. Support of both the private network routing capabilities and services delivered to the end enterprise user are provided within the AS supporting the HES application. In addition to the existing IMS capabilities, the HSS supports service profiles for SIP URIs with a URI parameter of user=phone and representing a PNP number.

8.2.2 Involved functional entities – originating

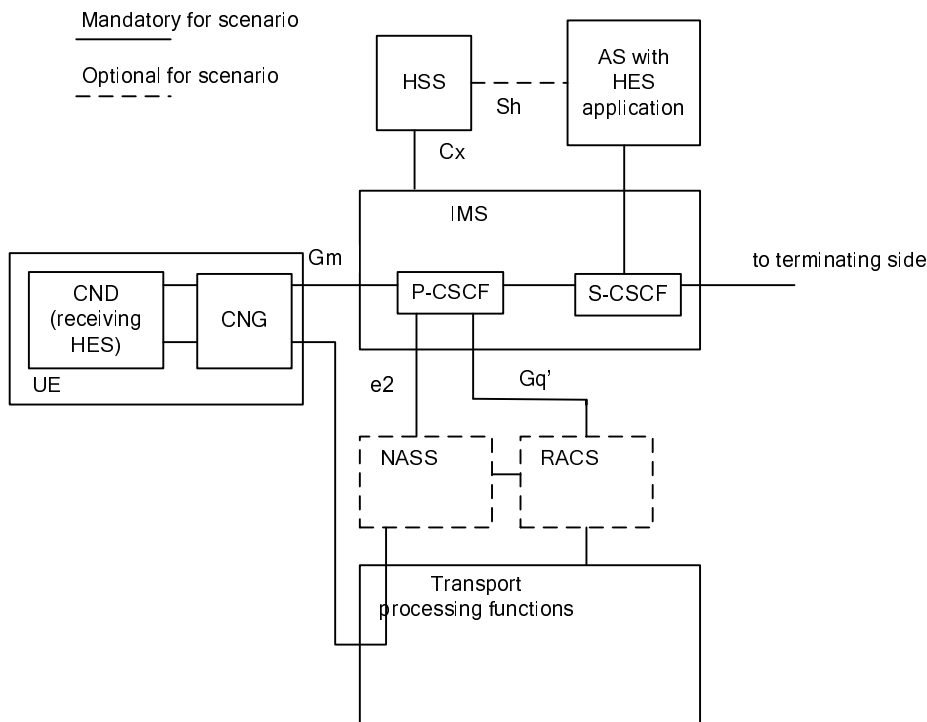

Figure 8.2.1: HES scenario originating functional entities (use of NASS and RACS)

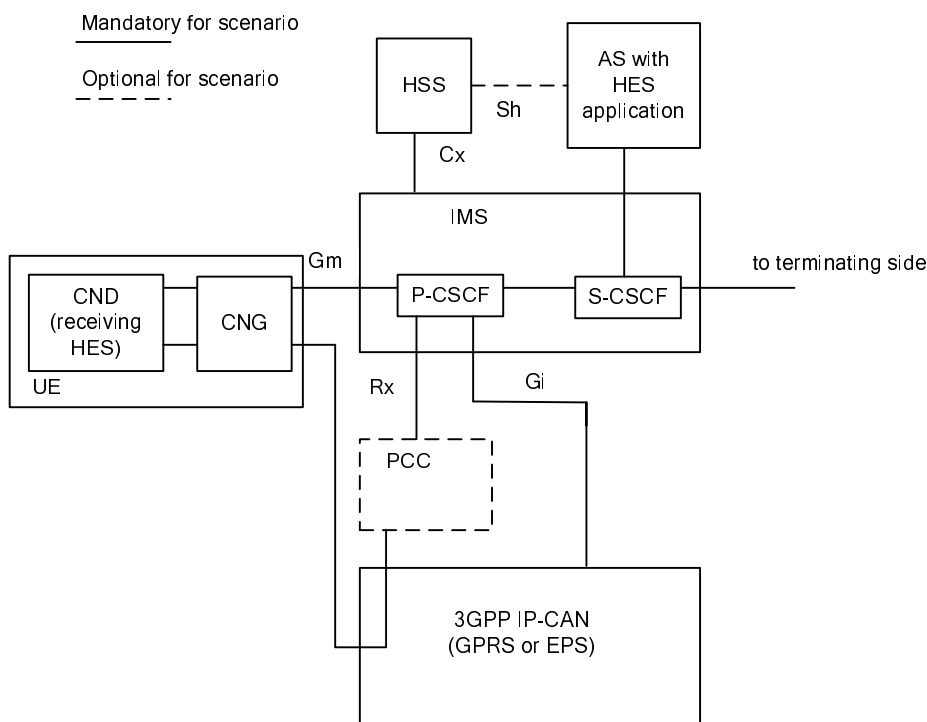

Figure 8.2.1A: HES scenario originating functional entities (use of PCC)

NOTE 1: Figure 8.2.1 and figure 8.2.1A do not show the intermediate functions between the P-CSCF and the S-CSCF, or those between the S-CSCF and the terminating side.

NOTE 2: In addition to the scenarios shown in figure 8.2.1 and figure 8.2.1A, the HES application can be supported by an enterprise connected using an ISC gateway function.

See 3GPP TS 24.524 [4] for further information.

8.2.3 Involved functional entities - terminating

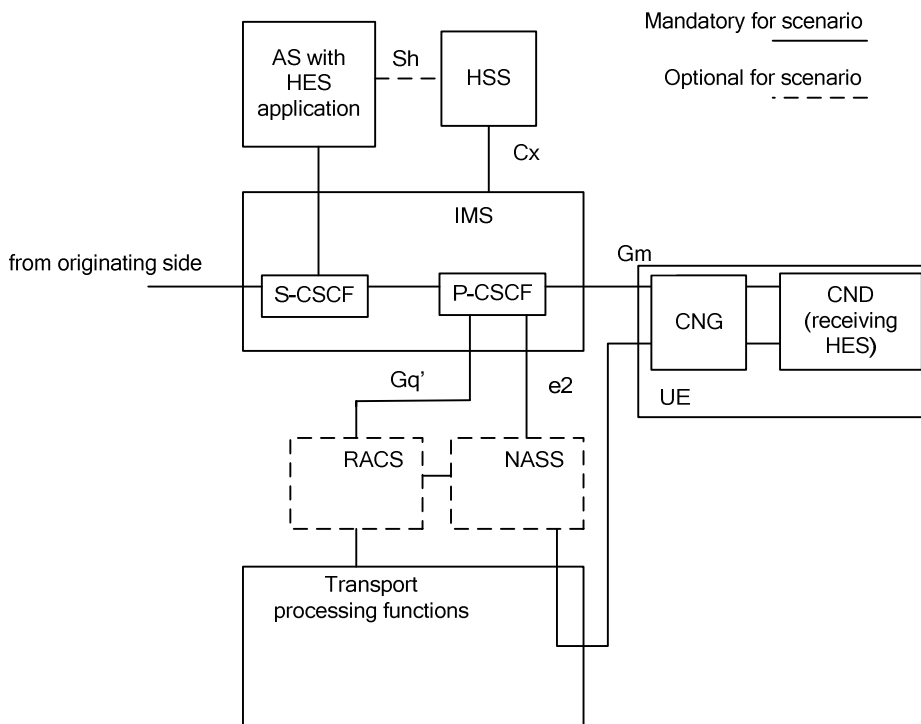

Figure 8.2.2: HES scenario terminating functional entities (use of NASS and RACS)

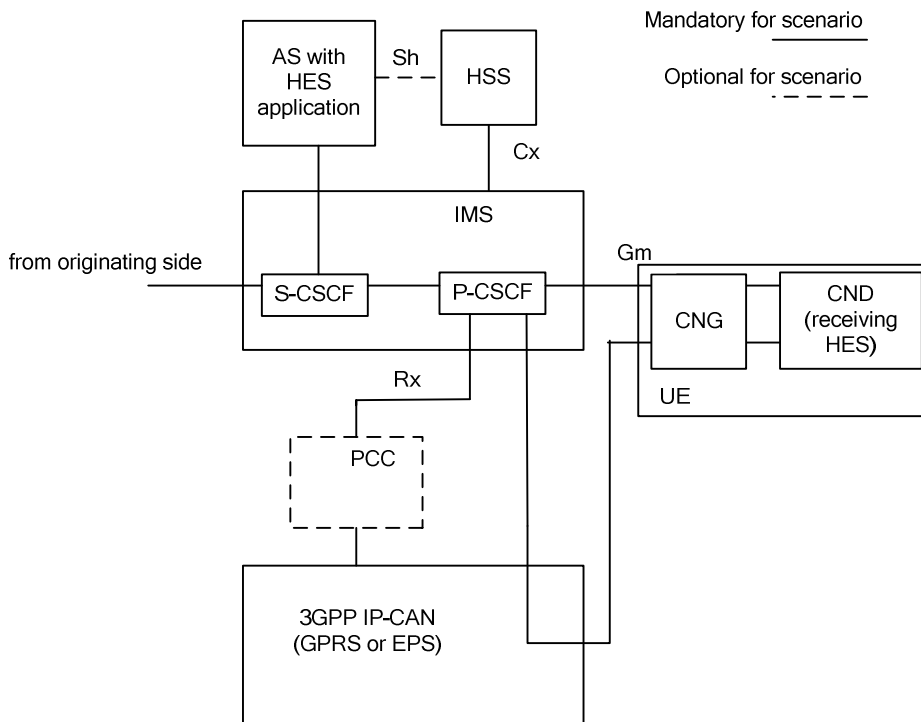

Figure 8.2.2A: HES scenario terminating functional entities (use of PCC)

NOTE 1: Figure 8.2.2 and figure 8.2.2A does not show the intermediate functions between the P-CSCF and the S-CSCF, or any intermediate functions before the S-CSCF from the originating side.

NOTE 2: In addition to the scenarios shown in figure 8.2.2 and figure 8.2.2A, the HES application can be supported by an enterprise connected using an ISC gateway function.

See 3GPP TS 24.524 [4] for further information.

8.2.4 Interoperability with other scenarios

The originating side HES scenario can interoperate with any other terminating scenario. A break-out function needs to be deployed when traffic leaves the enterprise environment and becomes public network traffic. This break-out function can form part of the HES application.

The terminating side HES scenario can interoperate with any other originating scenario. A break-in function needs to be deployed when public network traffic enters the enterprise environment. This break-in function can form part of the HES application.

8.2.5 Emergency calls

For a UE supported in the HES environment, citizen to authority calls are normally treated as if the UE was supported by the NGN in the normal public subscriber manner, see 3GPP TS 23.167 [1]. 3GPP TS 24.524 [4] for further information.

NOTE: Some enterprises may require alternative arrangements, whereby emergency calls are routed to a private PSAP.

8.2.6 Configuration / provisioning issues

HES users are configured in the HSS in the same manner as subscribers for the public NGN capabilities. The service profile and filter criteria relate to the provision of specialized HES by an application server. See 3GPP TS 24.524 [4] for further information. In addition to the existing IMS capabilities, the UPSF supports service profiles for SIP URIs with a URI parameter of user=phone and representing a PNP number.

The IMS routing functions (e.g. BGCF, S-CSCF, I-CSCF) will require appropriate provisioning to route private network traffic, unless all calls originated from or terminated to the HES are public network traffic.

8.2.7 Security issues

3GPP TS 24.524 [4] shall apply to the interconnection between the NGCN UE and the NGN.

NOTE: The present document references 3GPP TS 33.203 [7].

8.2.8 Charging issues

Inter Operator Identifiers (IOI) specific to the NGCN shall be exchanged between the S-CSCF supporting the hosted enterprise users and the entities supporting the remote side. See 3GPP TS 24.524 [4] for further information.

NOTE: IOI usage is not fully defined for enterprise communication in this release.

8.2.9 Transport control issues

The NASS, RACS and transport processing functions are used in an identical fashion to a CND and CNG receiving NGN services. See 3GPP TS 24.524 [4] for further information.

8.3.3 Involved functional entities - terminating

Figure 8.3.2 shows the functional entities involved in the terminating scenario in support subscription based business trunking.

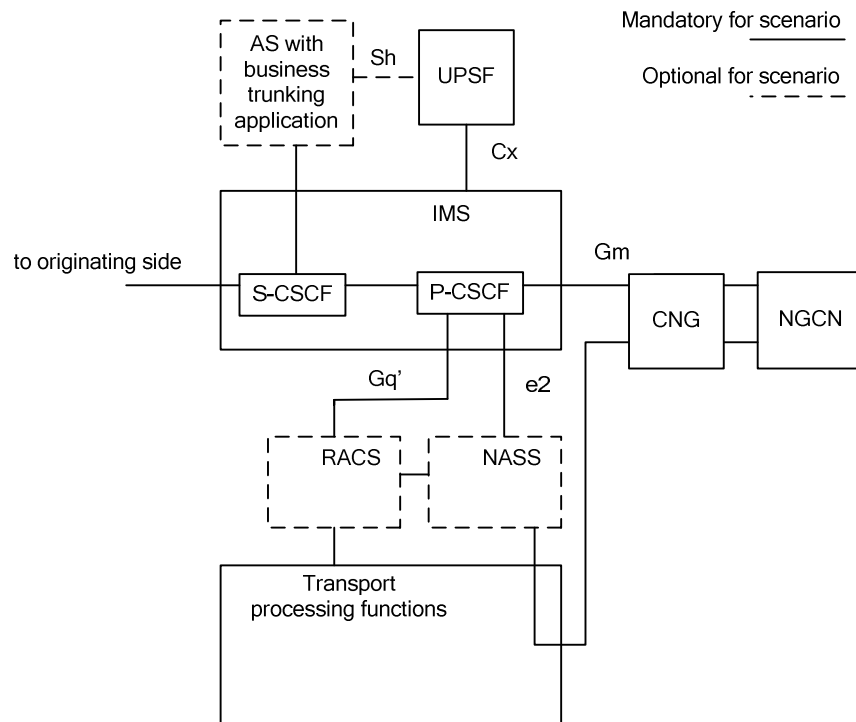

Figure 8.3.2: Business trunking scenario terminating functional entities

NOTE 1: Figure 8.3.2 does not show the intermediate functions between the P-CSCF and the S-CSCF, or any intermediate functions before the S-CSCF from the originating side.

NOTE 2: In addition to the scenarios shown in figure 8.3.1, the business trunking application can be supported by an enterprise connected using an ISC gateway function.

See 3GPP TS 24.525 [5] for further information.

8.3.4 Interoperability with other scenarios

The originating side business trunking scenario can interoperate with any other terminating scenario. A break-out function needs to be deployed when traffic leaves the enterprise environment and becomes public network traffic.

The terminating side business trunking scenario can interoperate with any other originating scenario. A break-in function needs to be deployed when public network traffic enters the enterprise environment.

8.3.5 Emergency calls

For an NGCN site that has a subscription to the IMS, emergency calls ingressing to the NGN are normally treated as if the NGCN was supported by the NGN in the normal public subscriber manner, see 3GPP TS 23.167 [1]. See 3GPP TS 24.525 [5] for further information.

NOTE: Some enterprises may require alternative arrangements, whereby emergency calls are routed to a private PSAP.

8.3.6 Configuration / provisioning issues

NGCN sites are configured in the HSS in the same manner as subscribers for the public NGN capabilities. The service profile and filter criteria relate to the provision of specialized enterprise services by the business trunking application; it is these services that are supported on an AS. See 3GPP TS 24.525 [5] for further information.

The IMS routing functions (e.g. BGCF, S-CSCF, I-CSCF) will require appropriate provisioning to route private network traffic, unless all calls originated from or terminated to the business trunking are public network traffic.

8.3.7 Security issues

3GPP TS 24.525 [5] shall apply to the interconnection between the NGCN UE and the NGN.

NOTE: The present document references 3GPP TS 33.203 [7] which contains the required provisions.

8.3.8 Charging issues

Inter Operator Identifiers (IOI) specific to the enterprise subscription for the NGCN shall be exchanged between the S-CSCF serving the NGCN site and the entities supporting the remote side. See 3GPP TS 24.525 [5] for further information.

NOTE: IOI usage is not fully defined for enterprise communication in this release.

8.3.9 Transport control issues

The NGCN site interfaces to the NGN using the CNG which can be an integral part of the NGCN equipment.

The media requirements identified by the control protocol use the transport processing functions, and may be supported by functionality in the NASS and RACS.

Static IP address assignment is valid and does not need NASS. MACF provides DHCP server dynamic address which is part of NASS. UAF is for authentication.

8.4 Scenario 6: Business trunking (peering based)

8.4.1 Introduction

This scenario describes the provision of capabilities of the NGN to support end users attached to an NGCN. In this case the NGCN operator has a service level agreement with the IMS operator. Services are provided to the private extensions behind the NGCN using the NGCN. The NGCN sites interface to the NGN using SIP as the control protocol.

Intelligent routing tables at the routing function are used to provide business trunking applications, e.g. those defined in 3GPP TS 22.519 [2], subclause 4.4. One mechanism to support such functionality is to use an AS attached to a transit function (see 3GPP TS 23.218 [11]) using the ISC interface. If such capabilities are not required, then the AS is not included in any request processing.

8.4.2 Involved functional entities – originating

Figure 8.4.1 shows the functional entities involved in the originating scenario in support of peering-based business trunking.

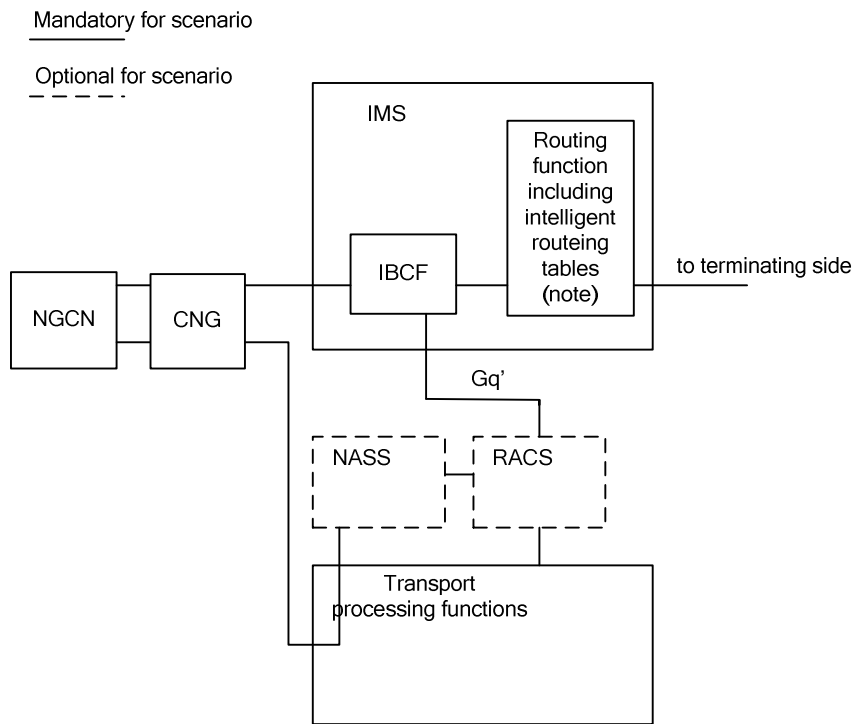

NOTE: One or more routing functional entities can appear in the originating side for this scenario.

Figure 8.4.1: Business trunking scenario originating functional entities

NOTE: For the functionality of the intelligent routing tables see subclause 6.2.6 of 3GPP TS 24.525 [5]). One mechanism to support such functionality is to use an AS attached to a transit function (see 3GPP TS 23.218 [11]) using the ISC interface.

See 3GPP TS 24.525 [5] for further information.

8.4.3 Involved functional entities - terminating

Figure 8.4.2 shows the functional entities involved in the terminating scenario in support of peering-based business trunking.

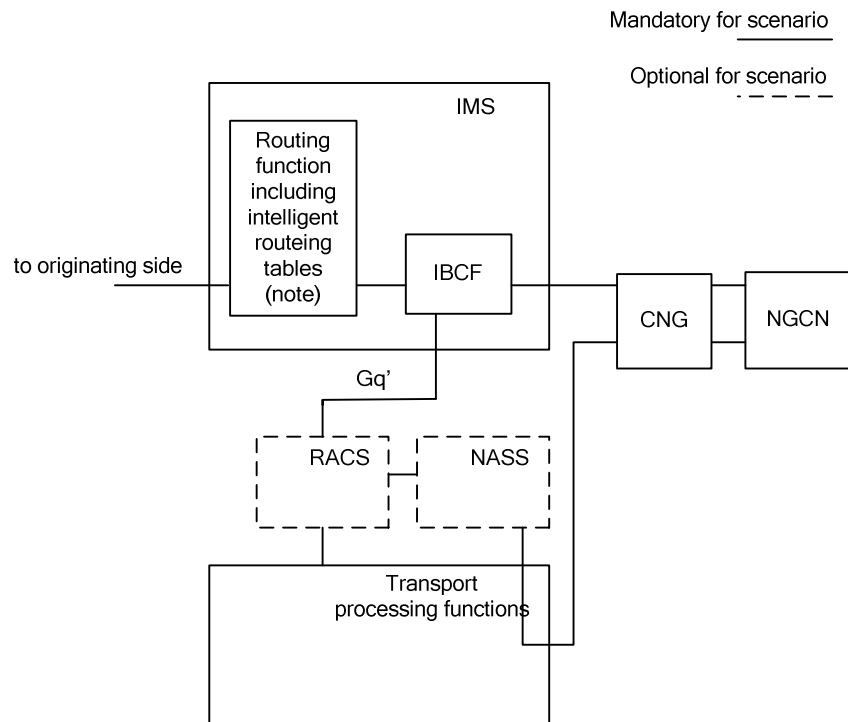

NOTE: One or more routing functional entities can appear in the originating side for this scenario.

Figure 8.4.2: Business trunking scenario terminating functional entities

NOTE: For the functionality of the intelligent routing tables see subclause 6.2.6 of 3GPP TS 24.525 [5]). One mechanism to support such functionality is to use an AS attached to a transit function (see 3GPP TS 23.218 [11]) using the ISC interface.

See 3GPP TS 24.525 [5] for further information.

8.4.4 Interoperability with other scenarios

The originating side business trunking scenario can interoperate with any other terminating scenario. A break-out function needs to be deployed when traffic leaves the enterprise environment and becomes public network traffic.

The terminating side business trunking scenario can interoperate with any other originating scenario. A break-in function needs to be deployed when public network traffic enters the enterprise environment.

NOTE: The functionality provided by the routing function is that of a SIP proxy, and the functionality provided by the IBCF is that of a session border controller, so interoperability can be provided with existing solutions not based on IMS. In this case, the procedures of 3GPP TS 29.162 [6] will apply at the interworking point. The possible functionalities of a session border controller are described in IETF RFC 5863 [9]. Such interworking may be limited by the SIP extensions that are supported across the interface. ETSI ES 282 001 [3] provides for an IWF which may also provide some appropriate functionality in this respect.

8.4.5 Emergency calls

None of the functional entities in this scenario have any functionality specific to the recognition of emergency calls or to the substitution of the Request-URI when such a call exists. Identification of emergency calls is therefore expected to

be performed in the NGCN. However, the routing tables are expected to be configured to route private network traffic in a manner different to public network traffic. Delivering emergency calls is integral to that routing configuration.

NOTE: Some enterprises may require alternative arrangements, whereby emergency calls are routed to a private PSAP.

8.4.6 Configuration / provisioning issues

NGCN sites are configured in the same manner as service level agreements with other public network operators. See 3GPP TS 24.525 [5] for further information.

The IMS routing functions will require appropriate provisioning to route private network traffic, and to provide the business trunking applications, unless all calls originated from or terminated to the business trunking are public network traffic.

8.4.7 Security issues

3GPP TS 24.525 [5] shall apply to the interconnection between the NGCN UE and the NGN.

NOTE: The present document references 3GPP TS 33.210 [10].

8.4.8 Charging issues

Inter Operator Identifiers (IOI) shall be exchanged between the NGCN and the NGN.

NOTE: IOI usage is not fully defined for enterprise communication in this release.

8.4.9 Transport control issues

NOTE: Definition of the transport control issues in this scenario is outside the scope of this release of the present document.

9 Scenarios relating to roaming

9.1 Scenario 7: NGCN user roaming into NGN public network

9.1.1 Introduction

This scenario describes the provision of capabilities of the NGN to support end users whose home location is an NGCN roaming into an NGN.

9.1.2 Involved functional entities

 Mandatory for scenario

 Optional for scenario

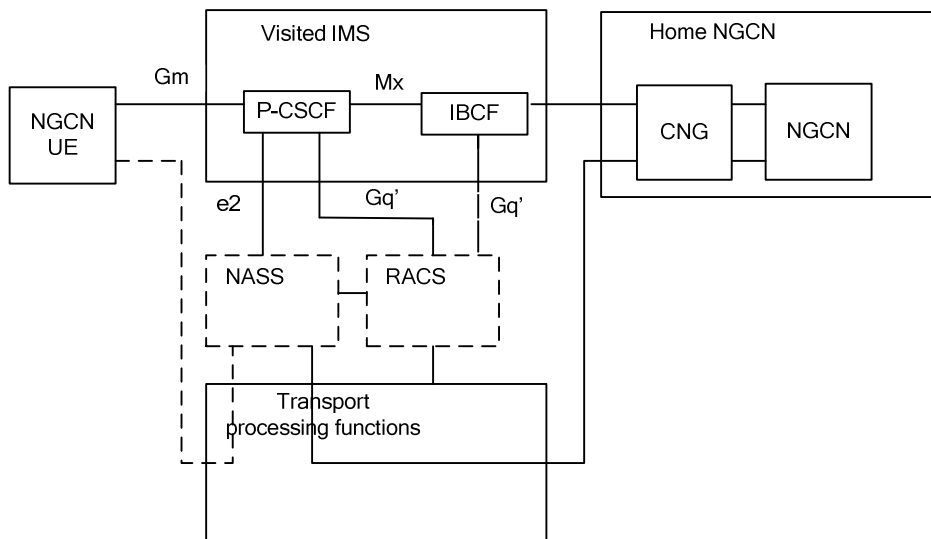

Figure 9.1.1: NGCN user registering from visited NGN with which NGCN has a roaming agreement

 Mandatory for scenario

 Optional for scenario

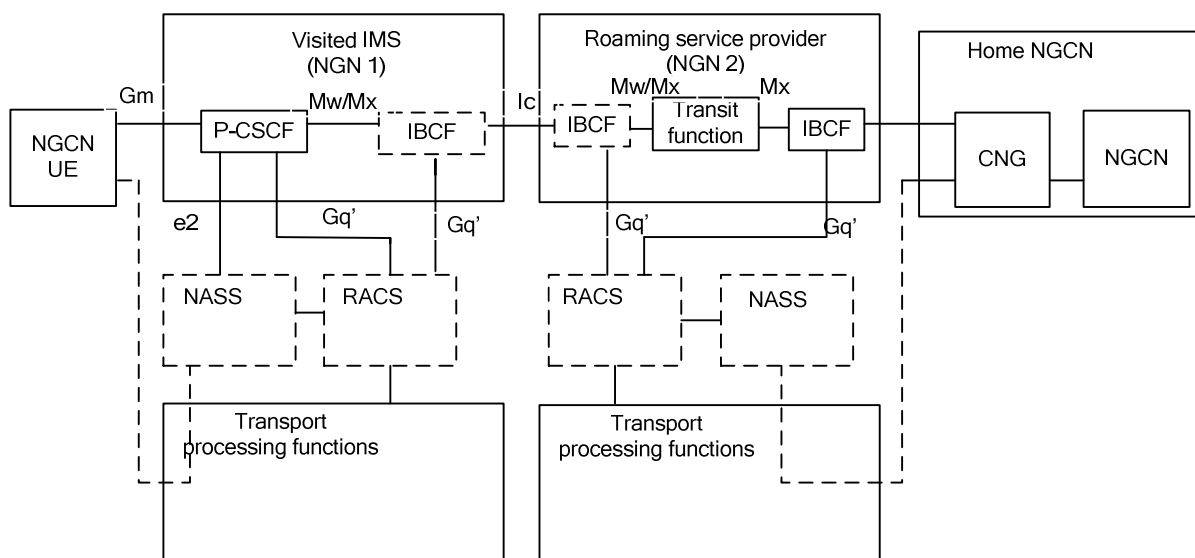

Figure 9.1.2: NGCN user registering from visited NGN via NGN with which both visited NGN and NGCN have a roaming agreement

NOTE: Functional entities in NGN with which the NGCN has a roaming agreement support either peering-based or subscription-based approach for business trunking.

A registration request submitted by an NGCN UE attached to a NGN is routed into the NGCN, either to the NGCN site directly when there exists a roaming agreement between the NGN and the NGCN; or indirectly via an NGN that has a roaming agreement with the NGCN which then transits the traffic to the home NGCN where the registrar is located. IBCF or equivalent functionality may exist at the network borders.

Other requests (e.g. for call establishment) are routed similarly to the proxy in the NGCN home site. Requests to the NGCN UE are sent in the opposite direction.

See 3GPP TS 24.525 [5] for further information.

9.1.3 Void

9.1.4 Interoperability with other scenarios

The Roaming NGCN User scenario can interoperate with any originating scenario and any terminating scenario. Specifically, a roaming NGCN user can:

- originate a call in which the user's home NGCN is the originating side of the NGCN transit scenario;
- originate a call in which the user's home NGCN is the originating side of a business trunking scenario (subscription-based or peering-based);
- terminate a call in which the user's home NGCN is the terminating side of the NGCN transit scenario;
- terminate a call in which the user's home NGCN is the terminating side of a business trunking scenario (subscription-based or peering-based).

9.1.5 Emergency calls

NOTE: Not addressed in this release of the document.

9.1.6 Configuration / provisioning issues

NOTE: Not addressed in this release of the document.

9.1.7 Security issues

NOTE: Not addressed in this release of the document.

9.1.8 Charging issues

NOTE: Not addressed in this release of the document.

9.1.9 Transport control issues

NOTE: Definition of the transport control issues in this scenario is outside the scope of this release of the present document.

9.2 Scenario 8: NGCN user roaming into another NGCN site of the same enterprise

9.2.1 Introduction

This scenario describes the provision of capabilities of the NGN to support end users whose home location is an NGCN site roaming into another NGCN site of the same enterprise. This scenario is not supported in the current release.

9.3 Scenario 9: HES user roams into NGCN site of the same enterprise

9.3.1 Introduction

This scenario describes the provision of capabilities of the NGN to support HES users whose home location is an NGN roaming into an NGCN site of the same enterprise. This scenario is not supported in the current release.

9.4 Scenario 10: HES user roams into another NGN

9.4.1 Introduction

This scenario utilizes existing NGN roaming capabilities.

9.5 Scenario 11: NGN public network user roaming into NGCN

9.5.1 Introduction

This scenario describes the provision of capabilities of the NGN to support end users whose home location is an NGN roaming into an NGCN. This scenario is not supported in the current release.

9.6 Scenario 12: NGCN user roaming into an NGCN of a different enterprise

9.6.1 Introduction

This scenario describes the provision of capabilities of the NGN to support end users whose home location is an NGCN roaming into another NGCN belonging to a different enterprise. This scenario is not supported in the current release.

Annex A (informative): Change history

Change history							
Date	TSG #	TSG Doc.	CR	Rev	Subject/Comment	Old	New
March 2014					Version for input to 3GPP CT1#86bis		0.0.0
April 2014					Version collecting comments from 3GPP CT1#86bis	0.0.0	0.0.1
May 2014					Version including revisions from CT1#87 from the following documents: C1-142086, C1-142087	0.0.1	0.1.0
June 2014	CT-64	CP-140282			Version 1.0.0 created for presentation for information and approval at CT-64	0.1.0	1.0.0
June 2014	Post CT-64				Version 12.0.0 created after approval at CT-64	1.0.0	12.0.0
September 2014	CT-65	CP-140653	0001		Recognition of VINE functional in business trunking scenarios	12.0.0	12.1.0
September 2014	CT-65	CP-140653	0002		Fixing non-specific versions of references	12.0.0	12.1.0
December 2014	CT-66	24.523	0004		Removal of further study items	12.1.0	12.2.0
December 2014	CT-66	24.523	0005	1	Intelligent routeing tables in peering-based business trunking	12.1.0	12.2.0
December 2015	CT-67	24.523			Upgrade to Rel-13	12.2.0	13.0.0

Change history							
Date	Meeting	TDoc	CR	Rev	Cat	Subject/Comment	New version
2017-03	CT-75					Upgrade to Rel-14	14.0.0
2018-06	SA-80	-	-	-	-	Update to Rel-15 version (MCC)	15.0.0
2020-07	SA-88e	-	-	-	-	Update to Rel-16 version (MCC)	16.0.0
2022-04	CT-95e	-	-	-	-	Update to Rel-17 version (MCC)	17.0.0
2024-04	-	-	-	-	-	Update to Rel-18 version (MCC)	18.0.0

History

Document history		
V18.0.0	May 2024	Publication