

ETSI TS 126 264 V18.0.0 (2024-07)



**Universal Mobile Telecommunications System (UMTS);
LTE;
5G;
IMS-based AR Real-Time Communication
(3GPP TS 26.264 version 18.0.0 Release 18)**



Reference

DTS/TSGS-0426264vi00

Keywords

5G,LTE,UMTS

ETSI

650 Route des Lucioles
F-06921 Sophia Antipolis Cedex - FRANCE

Tel.: +33 4 92 94 42 00 Fax: +33 4 93 65 47 16

Siret N° 348 623 562 00017 - APE 7112B
Association à but non lucratif enregistrée à la
Sous-Préfecture de Grasse (06) N° w061004871

Important notice

The present document can be downloaded from the
ETSI [Search & Browse Standards application](#).

The present document may be made available in electronic versions and/or in print. The content of any electronic and/or print versions of the present document shall not be modified without the prior written authorization of ETSI. In case of any existing or perceived difference in contents between such versions and/or in print, the prevailing version of an ETSI deliverable is the one made publicly available in PDF format on [ETSI deliver](#).

Users should be aware that the present document may be revised or have its status changed,
this information is available in the [Milestones listing](#).

If you find errors in the present document, please send your comments to
the relevant service listed under [Committee Support Staff](#).

If you find a security vulnerability in the present document, please report it through our
[Coordinated Vulnerability Disclosure \(CVD\)](#) program.

Notice of disclaimer & limitation of liability

The information provided in the present deliverable is directed solely to professionals who have the appropriate degree of experience to understand and interpret its content in accordance with generally accepted engineering or other professional standard and applicable regulations.

No recommendation as to products and services or vendors is made or should be implied.

No representation or warranty is made that this deliverable is technically accurate or sufficient or conforms to any law and/or governmental rule and/or regulation and further, no representation or warranty is made of merchantability or fitness for any particular purpose or against infringement of intellectual property rights.

In no event shall ETSI be held liable for loss of profits or any other incidental or consequential damages.

Any software contained in this deliverable is provided "AS IS" with no warranties, express or implied, including but not limited to, the warranties of merchantability, fitness for a particular purpose and non-infringement of intellectual property rights and ETSI shall not be held liable in any event for any damages whatsoever (including, without limitation, damages for loss of profits, business interruption, loss of information, or any other pecuniary loss) arising out of or related to the use of or inability to use the software.

Copyright Notification

No part may be reproduced or utilized in any form or by any means, electronic or mechanical, including photocopying and microfilm except as authorized by written permission of ETSI.

The content of the PDF version shall not be modified without the written authorization of ETSI.

The copyright and the foregoing restriction extend to reproduction in all media.

© ETSI 2024.
All rights reserved.

Intellectual Property Rights

Essential patents

IPRs essential or potentially essential to normative deliverables may have been declared to ETSI. The declarations pertaining to these essential IPRs, if any, are publicly available for **ETSI members and non-members**, and can be found in ETSI SR 000 314: "*Intellectual Property Rights (IPRs); Essential, or potentially Essential, IPRs notified to ETSI in respect of ETSI standards*", which is available from the ETSI Secretariat. Latest updates are available on the ETSI Web server (<https://ipr.etsi.org/>).

Pursuant to the ETSI Directives including the ETSI IPR Policy, no investigation regarding the essentiality of IPRs, including IPR searches, has been carried out by ETSI. No guarantee can be given as to the existence of other IPRs not referenced in ETSI SR 000 314 (or the updates on the ETSI Web server) which are, or may be, or may become, essential to the present document.

Trademarks

The present document may include trademarks and/or tradenames which are asserted and/or registered by their owners. ETSI claims no ownership of these except for any which are indicated as being the property of ETSI, and conveys no right to use or reproduce any trademark and/or tradename. Mention of those trademarks in the present document does not constitute an endorsement by ETSI of products, services or organizations associated with those trademarks.

DECT™, **PLUGTESTS™**, **UMTS™** and the ETSI logo are trademarks of ETSI registered for the benefit of its Members. **3GPP™** and **LTE™** are trademarks of ETSI registered for the benefit of its Members and of the 3GPP Organizational Partners. **oneM2M™** logo is a trademark of ETSI registered for the benefit of its Members and of the oneM2M Partners. **GSM®** and the GSM logo are trademarks registered and owned by the GSM Association.

Legal Notice

This Technical Specification (TS) has been produced by ETSI 3rd Generation Partnership Project (3GPP).

The present document may refer to technical specifications or reports using their 3GPP identities. These shall be interpreted as being references to the corresponding ETSI deliverables.

The cross reference between 3GPP and ETSI identities can be found under <https://webapp.etsi.org/key/queryform.asp>.

Modal verbs terminology

In the present document "**shall**", "**shall not**", "**should**", "**should not**", "**may**", "**need not**", "**will**", "**will not**", "**can**" and "**cannot**" are to be interpreted as described in clause 3.2 of the [ETSI Drafting Rules](#) (Verbal forms for the expression of provisions).

"**must**" and "**must not**" are **NOT** allowed in ETSI deliverables except when used in direct citation.

Contents

Intellectual Property Rights	2
Legal Notice	2
Modal verbs terminology.....	2
Foreword.....	4
1 Scope	6
2 References	6
3 Definitions of terms, symbols and abbreviations	6
3.1 Terms.....	6
3.2 Symbols.....	7
3.3 Abbreviations	7
4 System description	7
4.1 General	7
4.2 Terminal architecture	8
4.3 End-to-End Reference Architecture	9
5 Immersive AR Media	11
5.1 General	11
5.2 Speech	11
5.3 Video	11
5.4 Real-time text	11
5.5 Still images.....	11
6 AR Metadata	11
6.1 General	11
6.2 Metadata data channel message format	12
6.3 Spatial descriptions.....	13
6.3.1 Spatial description format.....	13
6.3.1.1 General	13
6.3.1.2 Available visualization space	13
6.3.1.3 Initial Pose.....	13
6.4 Scene descriptions	13
6.5.1 General.....	14
6.5.2 Pose Format	15
6.5.3 Action Format.....	15
7 Media configurations.....	15
8 AR Data Transport	16
8.1 General	16
8.2 RTP transport	16
8.3 RTCP usage.....	16
9 Quality of Experience.....	16
9.1 General	16
Annex A (normative): Call flows for IBACS	17
A.1 IMS AR communication Call Flows	17
A.1.1 General	17
A.1.2 AR Call Session Setup	17
A.1.3 Split Rendering Negotiation	17
A.1.4 Scene Description Processing.....	19
A.1.5 AR Media Processing.....	20
Annex (informative): Change history	22
History	23

Foreword

This Technical Specification has been produced by the 3rd Generation Partnership Project (3GPP).

The contents of the present document are subject to continuing work within the TSG and may change following formal TSG approval. Should the TSG modify the contents of the present document, it will be re-released by the TSG with an identifying change of release date and an increase in version number as follows:

Version x.y.z

where:

- x the first digit:
 - 1 presented to TSG for information;
 - 2 presented to TSG for approval;
 - 3 or greater indicates TSG approved document under change control.
- y the second digit is incremented for all changes of substance, i.e. technical enhancements, corrections, updates, etc.
- z the third digit is incremented when editorial only changes have been incorporated in the document.

In the present document, modal verbs have the following meanings:

- shall** indicates a mandatory requirement to do something
- shall not** indicates an interdiction (prohibition) to do something

The constructions "shall" and "shall not" are confined to the context of normative provisions, and do not appear in Technical Reports.

The constructions "must" and "must not" are not used as substitutes for "shall" and "shall not". Their use is avoided insofar as possible, and they are not used in a normative context except in a direct citation from an external, referenced, non-3GPP document, or so as to maintain continuity of style when extending or modifying the provisions of such a referenced document.

- should** indicates a recommendation to do something
- should not** indicates a recommendation not to do something
- may** indicates permission to do something
- need not** indicates permission not to do something

The construction "may not" is ambiguous and is not used in normative elements. The unambiguous constructions "might not" or "shall not" are used instead, depending upon the meaning intended.

- can** indicates that something is possible
- cannot** indicates that something is impossible

The constructions "can" and "cannot" are not substitutes for "may" and "need not".

- will** indicates that something is certain or expected to happen as a result of action taken by an agency the behaviour of which is outside the scope of the present document
- will not** indicates that something is certain or expected not to happen as a result of action taken by an agency the behaviour of which is outside the scope of the present document
- might** indicates a likelihood that something will happen as a result of action taken by some agency the behaviour of which is outside the scope of the present document

might not indicates a likelihood that something will not happen as a result of action taken by some agency the behaviour of which is outside the scope of the present document

In addition:

is (or any other verb in the indicative mood) indicates a statement of fact

is not (or any other negative verb in the indicative mood) indicates a statement of fact

The constructions "is" and "is not" do not indicate requirements.

1 Scope

The present document focuses on IMS-based conversational AR (Augmented reality) services. AR services can overlay media (e.g., video, audio, text, etc.) on top of the user's real perception. Conversational AR services as described by the present document typically include a bidirectional conversational A/V connection in addition to other non-real-time AR media for collaboration or communication between two or more users.

2 References

The following documents contain provisions which, through reference in this text, constitute provisions of the present document.

- References are either specific (identified by date of publication, edition number, version number, etc.) or non-specific.
- For a specific reference, subsequent revisions do not apply.
- For a non-specific reference, the latest version applies. In the case of a reference to a 3GPP document (including a GSM document), a non-specific reference implicitly refers to the latest version of that document *in the same Release as the present document*.

- [1] 3GPP TR 21.905: "Vocabulary for 3GPP Specifications".
- [2] 3GPP TS 26.114: "IP Multimedia Subsystem (IMS); Multimedia telephony; Media handling and interaction".
- [3] 3GPP TS 26.119: "Media Capabilities for Augmented Reality".
- [4] 3GPP TS 23.228: "IP Multimedia Subsystem (IMS); Stage 2".
- [5] 3GPP TS 24.229: "IP multimedia call control protocol based on Session Initiation Protocol (SIP) and Session Description Protocol (SDP); Stage 3".
- [6] 3GPP TS 26.565: "Split Rendering Media Service Enabler".
- [7] ISO/IEC 23090-14 AMD 2, Information technology — Coded representation of immersive media — Part 14: Scene description — Amendment 2: Support for haptics, augmented reality, avatars, Interactivity, MPEG-I audio, and lighting
- [8] 3GPP TS 26.522: "5G Real-time Media Transport Protocol Configurations".

3 Definitions of terms, symbols and abbreviations

3.1 Terms

For the purposes of the present document, the terms given in TR 21.905 [1] and the following apply. A term defined in the present document takes precedence over the definition of the same term, if any, in TR 21.905 [1].

AR data: Collection of information to be exchanged among participants in a call with AR experience. It includes AR media and AR metadata.

AR media: Media (e.g., audio, video, text or image) that will be rendered by the AR-MTSI client as an overlay over the user's real perception. This includes traditional 2D media (e.g., a 2D audio stream rendered to be perceived by the user to originate from their left side) and 3D media (e.g., spatial audio and volumetric video).

AR metadata: Data that provides information on AR media and its rendering. This includes pose, spatial descriptions and scene descriptions.

AR-MTSI client: A DCMTSI client supporting AR capabilities as defined by this specification.

AR MRF: An AR-MTSI client implemented by functionality included in the MRFC and the MRFP.

AR MF: An AR-MTSI client implemented by functionality included in the MF.

AR-MTSI client in terminal: An AR-MTSI client that is implemented in a terminal or UE. The term "AR-MTSI client in terminal" is used in this document when entities such as AR MF/MRF is excluded.

Split rendering: The procedure in which a UE offloads some of the media processing related to rendering tasks to a media function as considered for network centric AR IMS session procedures in TS 23.228 [4]

3.2 Symbols

Void

3.3 Abbreviations

For the purposes of the present document, the abbreviations given in TR 21.905 [1] and the following apply. An abbreviation defined in the present document takes precedence over the definition of the same abbreviation, if any, in TR 21.905 [1].

ADC	Application Data Channel
BDC	Bootstrap Data Channel
AS	Application Server
DC	Data Channel
DCSF	Data Channel Signalling Function
I-CSCF	Interrogating-CSCF
IMS	IP Multimedia Core Network Subsystem
MF	Media Function
MRF	Multimedia Resource Function
P-CSCF	Proxy-CSCF
S-CSCF	Serving-CSCF

4 System description

4.1 General

Typical conversational AR scenarios as envisioned in this document consist of an immersive AR call that may include the following conversational components:

- Real-time speech/audio that can comprise mono, stereo, and/or spatial audio.
- Real-time 2D video or 360-degree video that can be rendered as rectangular or spherical overlay in the AR experience.
- A real-time volumetric video of the user or an object that can be rendered in AR or MR.

In addition to the above conversational media, non-real-time objects may be exchanged over the data channel as well.

Both two-party and multiparty calls are possible. The AR experience may be unidirectional, i.e., only one party receives AR media and renders it, or it may be bidirectional, i.e., both parties receive and transmit AR media. The term AR-MTSI client includes both:

- an AR-MTSI client in terminal which is an AR device as defined in [3] e.g., AR glasses, phone, Head Mounted Display (HMD) that has an XR Runtime for rendering an AR experience.
- AR MF/MRF that provides support for AR conversational services.

As an AR-MTSI client in terminal is a DCMTSI client in terminal with additional features for AR communication, the following requirements for a MTSI client terminal also apply for an AR-MTSI client in terminal:

- the interworking requirements in clause 12 of TS 26.114 [2],
- the jitter buffer management requirements in clause 8 of TS 26.114 [2],
- the packet loss handling requirements in clause 9 of TS 26.114 [2],
- the media and rate adaptation requirements in clause 10 and 17 of TS 26.114 [2], and
- the network preference management object in clause 15 of TS 26.114 [2],

NOTE: If an AR-MTSI client in terminal supports functionalities for MSMTSI client in terminal as specified in Annex S of TS 26.114 [2], the media and rate adaptation requirements in Annex S.8 of TS 26.114 [2] also apply for an AR-MTSI client in terminal.

4.2 Terminal architecture

The detailed XR client architecture is not in the scope of this specification. The XR baseline client architecture can be found in [3]. The pre/post-processor component in terminal provides AR capabilities for processing output of peripherals and the input/output of encoders/decoders, which may include:

- XR runtime
- Scene manager
- Presentation engine
- XR source management

The AR-MTSI client has XR Runtime capabilities for rendering AR experience, e.g., spatial localization and mapping, etc., and can support local AR rendering and network-assisted split rendering based on client's capabilities. A UE may support multiple microphones, cameras or sensors.

An AR-MTSI client supports the protocol stack of a basic MTSI client as described in clause 4.2 of [2]. For the specific AR communication instance, AR-MTSI client can select different IMS media channel to delivery AR data to IMS network or peer UE. In general, AR media components with real-time characteristics are transported via RTP session and AR metadata is transported via data channel or RTP session with AR media.

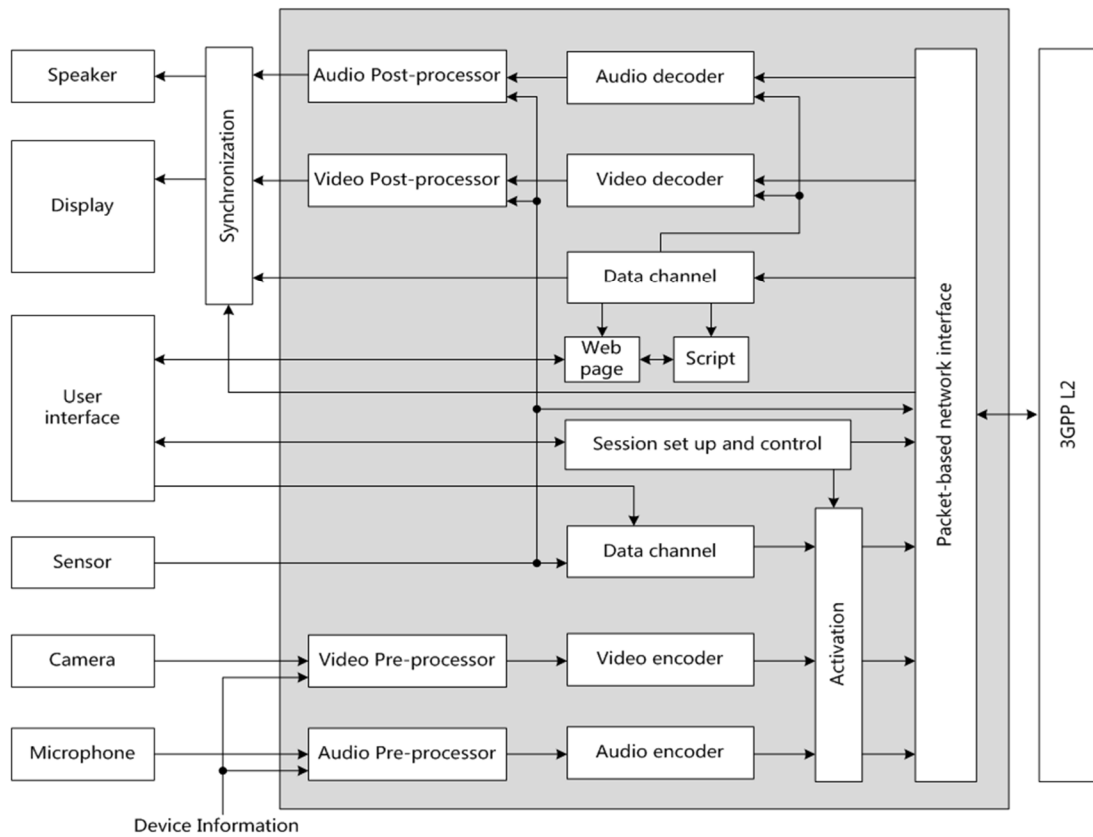

Figure 4.2.1: Functional components of an AR-MTSI client in terminal

4.3 End-to-End Reference Architecture

The end-to-end architecture to support AR communication over IMS can be found in TS 23.228 Annex AC [4]. The following Figure 4.3.1 is a simplified version showing the media functions within the scope of this specification.

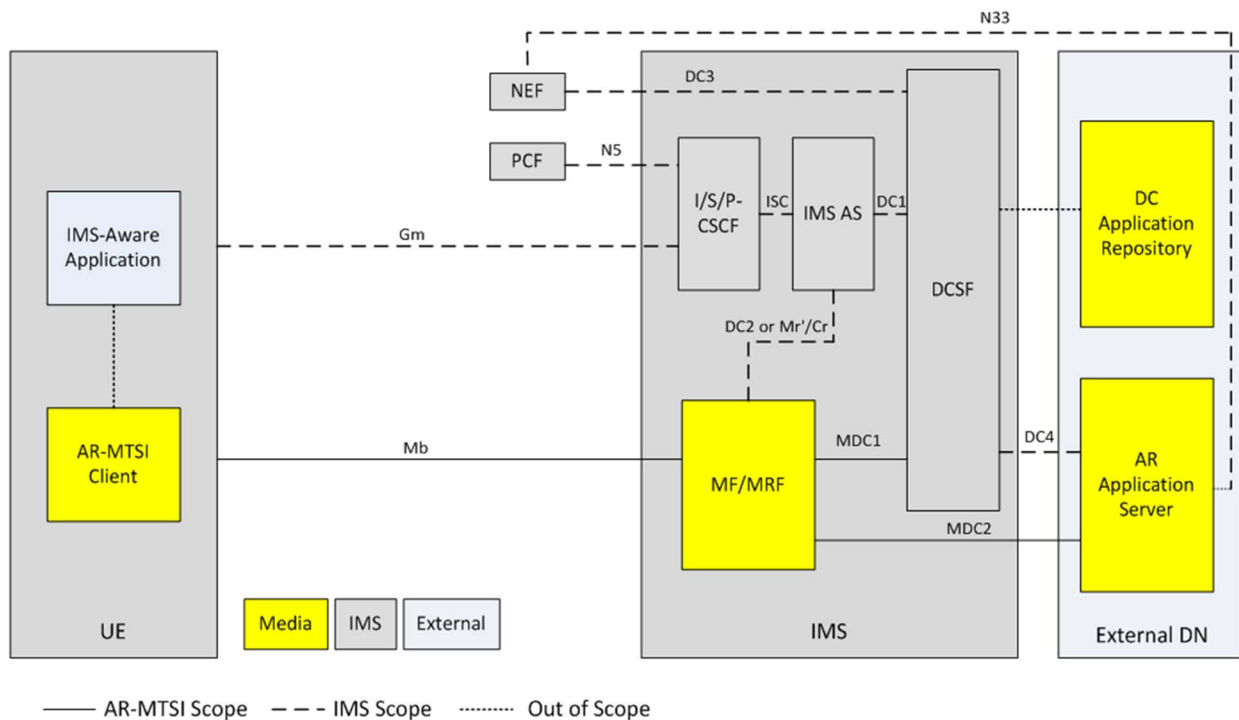

Figure 4.3.1: Generalized IMS DC Architecture to support AR communication

NOTE 1: General control-related elements over Gm interface, such as SIP signalling (TS 24.229 [5]), fall outside the scope of this specification, albeit parts of the session setup handling and session control for AR conversational media at Gm reference point, such as the usage of SDP and setup and control of the individual media streams between clients, are defined in this specification.

NOTE 2: DC Application Repository may be in external DN but can also be in operator domain. The DC Application Repository holds the application(s) that can be used in AR communication sessions and is out of scope of 3GPP.

AR Application Server (AR AS):

- AR Application Server is responsible for AR service control related to AR communication, including AR session media control and AR media capability negotiation with the UE.

NOTE 3: AR Application Server is a specific DC Application Server and is out of scope of 3GPP.

NOTE 4: The UE can download the AR metadata from AR AS through application data channel.

DCSF:

- The DCSF receives event reports from the IMS AS, and decides whether AR communication service is allowed to be provided during the IMS session. Additionally, the DCSF interacts with the AR AS for DC resource control.

MF/MRF:

- Support AR conversational service by providing transcoding for terminals with limited capabilities. Additionally, the MF/MRF may collect spatial and media descriptions from UEs and create scene descriptions for symmetrical AR call experiences.
- Provide remote rendering for AR-MTSI clients in terminals with limited capabilities based on rendering negotiation. For remote rendering the AR-MTSI client provides AR metadata, e.g., pose data, as defined in clause 6 of this specification.

IMS AS:

- The IMS AS receives the media control instructions from the DCSF and accordingly interacts with the UE for connecting the UE's audio/video media termination to the MF/MRF [4], and interacts with MF/MRF for data channel media resource management for AR media processing.

5 Immersive AR Media

5.1 General

An AR-MTSI client supports simultaneous transfer of multiple media components with real-time characteristics. An AR-MTSI client supports the core media components in [2] for a conversational AR scenario including text, image, video and speech (also referred to as audio).

5.2 Speech

AR-MTSI client in terminal offering speech communication shall follow clause 5.2.1 in TS 26.114 [2]. In order to support minimum service interoperability, an AR-MTSI client in terminal shall implement the UE codec and media handling requirements as specified in TS 26.114 [2].

5.3 Video

AR-MTSI client in terminal offering video communication shall follow clause 5.2.2 in TS 26.114 [2] and may render it as based on AR metadata (in clause 6) and media configuration (in clause 7). In order to support minimum service interoperability, an AR-MTSI client in terminal shall implement the UE codec and media handling requirements as specified in TS 26.114 [2].

Specifically, the AR-MTSI client in terminal may support Overlays and Scene Description-Based Overlays (as described in TS 26.114 [2] in clause Y.6.4 and Y.6.9) to render video elements in parts of the AR environment. This may result into rendering the video stream (or parts of the video stream) in a sub-area of the display device. Further, the UE may negotiate a stream characteristic most suitable for the sub-area and may renegotiate the stream characteristics in case the sub-area changes.

5.4 Real-time text

AR-MTSI client in terminal offering real-time text shall follow clause 5.2.3 in TS 26.114 [2] and may render it as defined in the AR metadata (in clause 6).

5.5 Still images

AR-MTSI client in terminal supporting still images shall follow clause 5.2.4 in TS 26.114 [2] and may render it as defined in the AR metadata (in clause 6).

6 AR Metadata

6.1 General

Real-time scene creation for an AR conference with two or more participants may be done by the MRF to create a symmetric experience for all participants. For an MRF to create a scene, it may request the following information from the UEs:

- spatial description of the space surrounding the UE e.g., the occlusion-free space around the user in which the AR media will be rendered.

- media properties indicating the AR media that the UE will be sending, and thus have to be incorporated in the scene.
- receiving media capabilities of the UEs, which may include
 - UE media decoding capabilities
 - UE hardware capabilities (e.g., the display resolution)
- information based on detecting the location, orientation, and capabilities of physical world devices, eligible for usage in an audio-visual communications session

Based on this information the MRF creates a scene which includes:

- defining the placement of the user and the AR media in that scene, including e.g., the position, size, depth from the user, anchor type, and recommended resolution (or quality)
- specific rendering properties for the AR media, e.g., for a 2D object to be rendered with a billboard effect

The MRF can then share the scene with the participant UEs using a supported scene description format. This scene description may be different for different UEs.

NOTE: The scene as sent by the MRF allows the UE to 1) select and request any related media (for example, in a quality and bitrate based on the rendering characteristics or network connection), 2) render the complete scene on a (virtual) display device, and 3) update the rendering and requested media dynamically (e.g., according to the movement and view orientation of the user).

6.2 Metadata data channel message format

For the carriage of metadata defined in this clause the AR-MTSI clients shall use the data channel. The data channel sub-protocol shall be identified as “3gpp-ar-metadata”, which shall be included in the dcmpp attribute of the SDP.

The transmission order for the data channel shall be set to in-order and the transmission reliability shall be set to reliable.

The metadata message format shall be set to text-based and the messages shall be UTF-8 encoded JSON messages.

A data channel message may carry one or more AR metadata messages as defined in Table 6.2-1.

Table 6.2-1 AR Metadata Messages Format

Name	Type	Cardinality	Description
messages	Array(Message)	1..n	A list of AR metadata messages. Each message shall be formatted according to the Message data type as defined in Table 6.2-2

Each metadata message shall follow the format specified in Table 6.2-2.

Table 6.2-2 AR Metadata Message Data Type

Name	Type	Cardinality	Description
id	string	1..1	A unique identifier of the message in the scope of the data channel session.
type	string	1..1	A urn that identifies the message type.
payload	object	1..1	The message payload depends on the message type.

sendingAtTime	number	0..1	The wall clock time when the AR metadata message is transmitted. (clause 9.3.2.1 in TS 26.565 [6])
---------------	--------	------	--

6.3 Spatial descriptions

6.3.1 Spatial description format

6.3.1.1 General

A spatial description format is used for defining the physical space around a UE or trackable in which virtual content can be inserted. This clause includes the supported formats and the method for exchanging the information between AR-MTSI clients.

6.3.1.2 Available visualization space

An AR-MTSI client in terminal may send available visualization space, user position and other trackable poses to AR MF/MRF for scene creation and update.

The available visualization space defines an occlusion-free space around the user for rendering the AR scene as a geometric primitive. The format for available visualization space is defined in clause 6.2.4 of [3]. The type of the message containing visualization space as a payload shall be “**urn:3gpp:ar:v1:visualization-space**”. The availableVisualizationSpace object [3] shall contain a *xrSpaceId*. The *xrSpaceId* is used for determining the local coordinate axis of the visualization space. The *xrSpaceId* shall be a unique identifier for an XR space of one AR-MTSI client in terminal. If the visualization space is sent, then initial user pose shall be sent. The user pose and visualization space are in reference to the same *xrSpaceId*.

If the visualization space is anchored to another trackable (instead of the user) not anchored around the user or if the viewer is not the centre of the visualization space, an initial pose for a trackable as defined in clause 6.3.1.3 may be used.

6.3.1.3 Initial Pose

Trackable is a real-world object (e.g., the UE, floor, controllers, table etc.) that the UE can detect, which can be used as a reference to anchor virtual objects to the real world.

The AR-MTSI client in terminal that sends the available visualization space may also send at least one pose for a trackable within the visualization space. The AR-MTSI client in terminal may send additional poses for anchoring virtual objects. The poses shall be sent using the format defined in clause 6.2.2 of [3]. The poseInfo (as defined in Table 6.2.2-1 [3]) shall contain an *xrSpaceId* that is the same as the one used for visualization space. The poses may additionally contain a label string to identify the type of anchor. The labels are application-dependent, but for example, user, floor, left controller etc., can be used as labels. The type of the message for a pose sent for scene creation shall be set to “**urn:3gpp:ar:v1:initial-pose**”.

6.4 Scene descriptions

An AR-MTSI client in terminal that is a compliant device type of TS 26.119 [3] shall support the capabilities requirements for scene description as described in clause 10 of TS 26.119 for its respective device type.

When used in an AR call, the scene description should be the entry point to the AR session (after establishment of a regular call/conference) and shall be exchanged over the data channel as described in [2]. The Scene Description is exchanged over a stream with a stream id in the range 1 to 1000 and shall be provided by the AR AS through the MF/MRF to the AR-MTSI client in terminal. In this case, no web application needs to be downloaded in this case.

Based on the information in the Scene Description, the UE may decide to add additional media streams through a re-INVITE. However, at least the RTP session for the voice of every participant should be present and should be linked to an audio source in the scene description.

NOTE: Support for advanced audio codecs, such as IVAS, in scene description is FFS.

Each participant should be associated with their own camera node, identified through the node name, which is also provided as part of the SDP through the “sd-nodes” attribute of media session of the data channel that carries the Scene Description.

The “sd-nodes” attribute shall conform to the following ABNF syntax:

```
sd-nodes = "a=sd-nodes:" SP participant-label SP 1*(node-name [","])
participant-label = char-val
node-name = char-val
```

The AR MF/MRF should apply pose updates from the received pose information of each participant to their respective camera nodes, as negotiated by the SDP sd-nodes attribute.

A scene description of an AR session may be sent from the AR MF/MRF to the AR-MTSI clients in terminal.

An AR MF/MRF that supports scene description shall support:

- The capability to generate a scene description file that conforms to the **SD-Rendering-gLTF-Core** capability as defined in [3].
- The capability to generate and update a scene description file that conforms to the **SD-Rendering-gLTF-Ext1** as specified in [3].

An AR MF/MRF that supports scene description may additionally support the generation of scene description files and updates that conform to the **SD-Rendering-gLTF-Ext2** capabilities as defined in [3].

An AR MF/MRF that supports scene description may additionally support the generation of scene description files and updates that conform to the **SD-Rendering-gLTF-Interactive** capabilities as defined in [3].

In addition, an AR MF/MRF that supports scene description shall support the referencing of RTP streams in the scene description through the **MPEG_media** extension as defined in [7]. The external media shall be RTP media streams supported by an AR-MTSI client and signalled in the SDP.

When scene description is not used as the entry point, the scene description shall be sent by the AR MF/MRF to the AR-MTSI client in terminal over the application data channel. The type of the message shall be set to “**urn:3gpp:ar:v1:sd**”.

An AR MF/MRF that supports scene descriptions should create and distribute the scene for an AR call with audio and video streams based on the visualization space, viewer position and AR media properties. The AR MF/MRF should create the scene description for each participant (AR-MTSI client in terminal) such that the shared experience is symmetrical for the different users in the call, e.g., to maintain relative position of users and objects.

6.5 Network media rendering

6.5.1 General

The AR-MTSI client in terminal supporting network media rendering (of AR Media objects or 3D scenes) shall support metadata formats for split rendering as specified in clause 8.3 of TS 26.565 [6].

Note: In case network media rendering is used, AR Media objects or 3D scenes are rendered in a split rendering server (AR AS) based on the XR pose information and actions of the AR-MTSI client in terminal. The split rendering server renders a view of the scene (or object) based on the viewing angles and XR pose, provided by the AR-MTSI client in terminal. The resulting images are sent as video streams from the split rendering server to the AR-MTSI client in terminal, which renders the videos at their respective position in AR.

6.5.2 Pose Format

When the network media rendering is activated, the AR-MTSI client in terminal periodically transmits a set of pose predictions to the AR AS. The pose prediction format shall conform to the payload of the message whose type is "**urn:3gpp:split-rendering:v1:pose**" as specified in clause 8.3.2.2 of TS 26.565 [6].

6.5.3 Action Format

The action sets and actions are negotiated during the AR media rendering negotiation. The AR-MTSI client in terminal reports any changes to action state as it occurs by sending updated actions to the AR AS after the network media rendering is activated. When the AR-MTSI client in terminal sends updated actions to the AR AS, the action format shall conform to the payload of the message whose type is "**urn:3gpp:split-rendering:v1:action**" as specified in clause 8.3.2.3 of TS 26.565 [6].

7 Media configurations

7.1 General

The media configuration requirements for MTSI clients in terminals specified in TS 26.114 [2], clause 6, also apply for AR-MTSI client in terminal.

An SDP framework for AR data exchange for AR communication is presented to negotiate codec support for AR media, AR metadata, as well as RTP/RTCP signalling necessary for AR media rendering processing.

AR-MTSI client in terminal shall use RTP for the real-time transport of AR media for AR communication. Any AR media as an overlay may refer to the overlay configuration described in clause Y 6.4.3 of TS 26.114 [2].

AR-MTSI client in terminal shall use the data channels for exchange of AR metadata and rendering negotiation. The SDP attribute *3gpp_armetadadata_types* should be used to indicate the types of AR metadata which defined in clause 6 (e.g. pose, action and scene description) within the data channel.

The syntax for the SDP attribute is:

```
a=3gpp_armetadadata_types: <metadata-1> / ... / <metadata-N>
```

The poses as part of AR metadata may be transmitted via RTP session as a RTP header extension which specified in clause 4.3 of TS 26.522 [8].

7.2 Network media rendering configuration

The AR-MTSI client in terminal shall indicate its support for AR calls by including the "webrtc-datachannel" in the "+sip.sub-type" Contact header field.

A new Contact header field parameter, "+sip.3gpp-ar-support" is used to indicate the level of support for AR calls. The possible values for the "3gpp-ar-support" parameter are:

- "**ar-capable**": indicates that the terminal is fully capable of receiving and rendering AR media as described by the capabilities in [2] clause 9.2.
- "**ar-assisted**": indicates that the terminal is capable of transmitting AR metadata on the uplink. However, the UE has no support for processing and rendering a 3D scene. The participation in an AR call requires the deployment of network rendering. The rendered view(s) are controlled by the pose information that is shared by the terminal.

In the absence of the "+sip.3gpp-ar-support", it shall be assumed that the terminal has no support for AR calls. In this case, the MTSI client can only participate in the AR call if network rendering is offered.

An AR-MTSI terminal that intends to participate in an AR call shall register with the "**ar-capable**" value for the "+sip.3gpp-ar-support" parameter and shall offer/answer an SDP that includes a data channel with the sub-protocol "mpeg-sd". Any updates that the AR-MTSI terminal intends to share, including pose updates, will be sent as scene

updates to the AR AS. An AR-MTSI terminal that intends to participate in an AR call with the support for network rendering shall register with the “**ar-assisted**” value for the “+sip.3gpp-ar-support” parameter and shall offer/answer an SDP that includes a data channel with the sub-protocol “3gpp-sr-metadata”. Pose updates that are to be used for the rendering are shared as pose predictions with the MF/MRF.

As specified in Annex AC.9 of TS 23.228 [4], the AR application server may provide network assisted rendering. An AR-MTSI client in terminal can decide to request network media rendering based on user selection and its status such as power, signal, computing power, internal storage, etc. The AR-MTSI client in terminal shall complete an AR media rendering negotiation with the AR AS before it initiates subsequent procedures to activate the network media rendering. The data channel should be established for rendering negotiation with SDP offer/answer between AR-MTSI client in terminal and MF/MRF with the sub-protocol “3gpp-sr-conf”, and continue to be used for rendering re-negotiation until the end of the AR communication.

An **AR-assisted** terminal that intends to deploy network rendering for AR media rendering, shall use the negotiation processes between the AR-MTSI client in terminal and the AR AS to determine the split rendering configuration. The split rendering configuration shall be in JSON format as specified in clause 8.4.2 of TS 26.565 [6]. The exchange of the configuration information shall take place using the established MTSI data channel. The split rendering configuration message shall be formatted according to clause 8.4.2.2 of TS 26.565 [6] and shall have the type: “**urn:3gpp:split-rendering:v1:configuration**”. The output description message shall be formatted according to clause C.1.4 of TS 26.565 [6] and shall have the type: “**urn:3gpp:split-rendering:v1:output**”.

For a terminal that does not support AR calls, the IMS AS may trigger network rendering on behalf of the terminal upon receiving an (re)INVITE for an AR call. The output format for the rendered media shall be conformant to 10.4.3 and 10.4.4 of TS 26.119 [3]. The MF/MRF that performs the remote rendering shall select a suitable rendering viewpoint for the session, e.g. a selected viewpoint in the scene or the initial viewpoint for the participant as assigned by the AR AS in the scene description. In case no network rendering can be setup, the IMS AS should reject the call.

The IMS AS detects support for AR capabilities based on the presence or absence of the “+sip.3gpp-ar-support” parameter of the Contact Header Field in the REGISTER message.

8 AR Data Transport

8.1 General

The data transport requirements for MTSI clients in terminals specified in TS 26.114 [2], clause 7, also apply for AR-MTSI clients in terminals.

8.2 RTP transport

Additionally to the requirements specified in TS 26.114 [2], clause 7, the RTP Header Extension for PDU Set Marking (clause 4.2) and XR Pose (clause 4.3) specified in TS 26.522 [8] also apply for AR-MTSI clients in terminals.

8.3 RTCP usage

Additionally to the requirements specified in TS 26.114 [2], clause 7, the Transmission of timing information data for QoE measurements specified in TS 26.522 [8], clause 5.2, also applies for AR-MTSI clients in terminals.

9 Quality of Experience

9.1 General

Quality of Experience (QoE) requirements for MTSI clients in terminals specified in TS 26.114 also apply for terminals to be specified by this specification. Further, extensions to those QoE requirements are for future studies (and expected once extensions are made to the AR media formats).

Annex A (normative): Call flows for IBACS

A.1 IMS AR communication Call Flows

A.1.1 General

Figure A.1.1-1 illustrates a high-level call flow for AR communication.

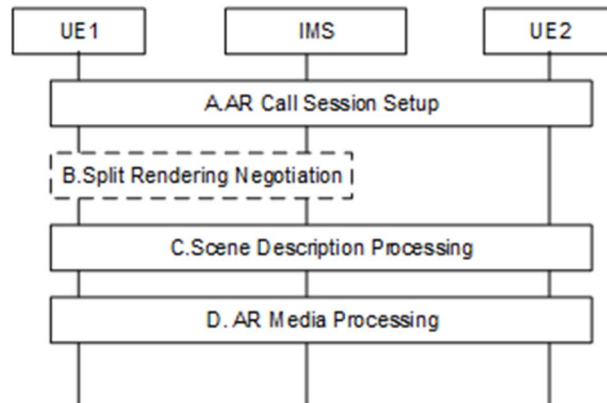

Figure A.1.1-1: High-level call flow for AR communication

The following steps are performed:

- A. AR Call Session Setup: UE1 initiates an AR call, and the AR call session is established between UE1 and UE2, data channels along with audio and video channels are established between UE and network
- B. Split Rendering Negotiation: When the UE has poor rendering capability which is not able to satisfy the requirements of AR communication, the split rendering negotiation is involved between the UE and IMS. The split may be adjustable during a session. This split rendering negotiation step can be executed/re-executed during the session when the UE's status changed and/or user selection.
- C. Scene Description Processing: Prepare and generate scene description updates for the AR call session, this procedure can be done either on UE or IMS network.
- D. AR Media Processing: AR media & Metadata transmission and AR media rendering for the AR call session, if split rendering is enabled, this procedure can be done by both UE and IMS network.

A.1.2 AR Call Session Setup

The AR call session procedure shall be followed as specified in clause AC.7 of TS 23.228 [4].

A.1.3 Split Rendering Negotiation

Figure A.1.3-1 illustrates a detailed call flow for split rendering procedure.

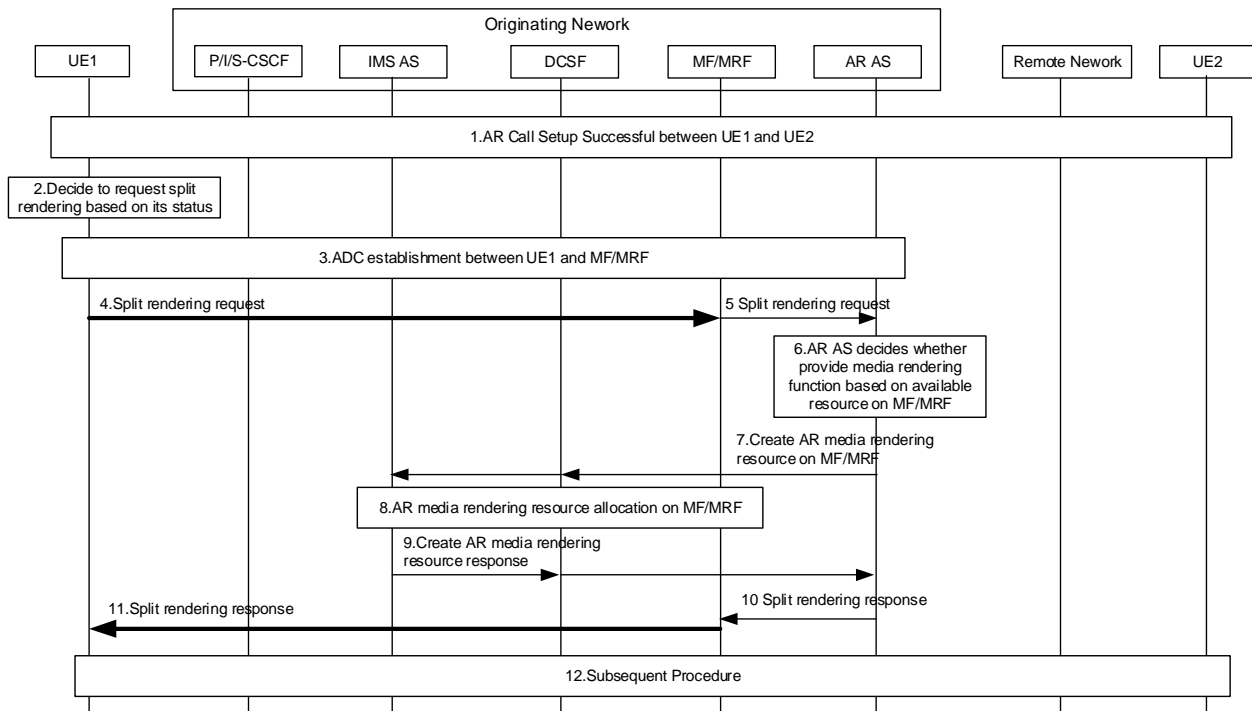

Figure A.1.3-1: Call Flow for Split Rendering Negotiation

The steps are as follows:

1. The UE1 initiates an AR communication session and establishes audio and video session connections with the UE2. Then the bootstrap and application data channels are established for the UE1 and UE2.
2. When the UE1 discovers that its media capabilities cannot meet the AR communication related media rendering requirements, the UE1 decides to start split rendering call flow. Then the UE1 calculates which AR objects can be rendered by itself based on its status, and decides which part of the AR objects to be rendered in the UE1 and the others to be rendered in the IMS network.
3. The UE1 initiates the application data channels between the UE1 and the MF/MRF, for the split rendering request and metadata transmission.
- 4-5. The UE1 sends a Split Rendering Request to the MF/MRF through the established application data channel, the request includes the information of the AR objects to be rendered in IMS network, the MF/MRF transfers the request to the AR AS.

Note: The use of data channel for split rendering procedure (steps 2, 4 and 5) is optional. Alternatively, the MF/MRF or AR AS may decide to use split rendering for media delivery based on, e.g., device capability and media properties.

6. The AR AS may decide whether to provide AR media rendering function based on the request message received from the UE1, the media rendering resource available on the MF/MRF and the split rendering provisioning status for the UE1.
7. The AR AS sends a request to the DCSF to create required AR media rendering resource on the MF/MRF for the AR objects that should be rendered in IMS network, the DCSF transfers the request to the IMS AS.

NOTE: The requested AR media rendering resources are such that they can accommodate expected changes in scene description for the session.

8. The IMS AS sends the media resource allocation request to the MF/MRF, to reserve AR media rendering resource for the UE1.
9. When the MF/MRF resources are allocated successfully, the IMS AS returns a successful response to the DCSF, the DCSF transfers the response to the AR AS.

10-11 The AR AS returns a successful Split Rendering Response carrying the result to the MF/MRF. The MF/MRF then transfers the response/notification message with split rendering configuration information to the UE1 through the application data channel.

12. Subsequent procedures continue.

A.1.4 Scene Description Processing

Figure A.1.4-1 illustrates a detailed call flow for scene description processing procedure.

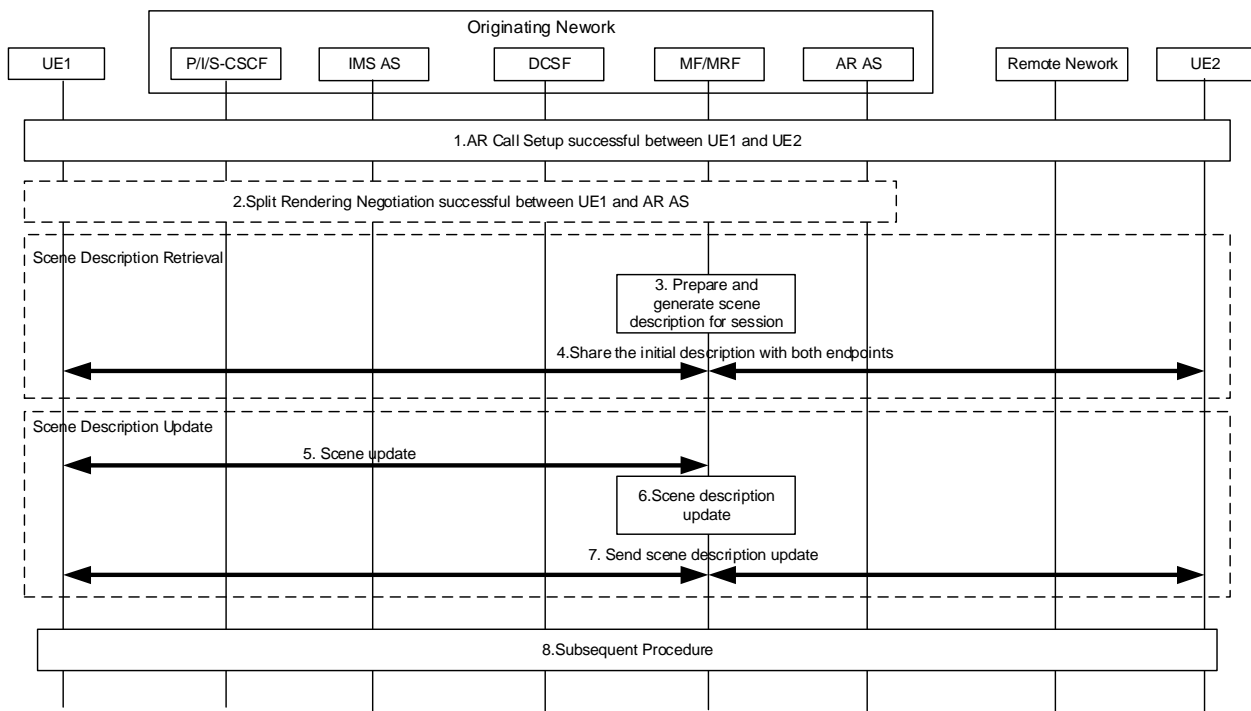

Figure A.1.4-1: Call Flow for Scene Description Processing

The steps are as follows:

1. The UE1 initiates an AR communication session and establishes audio and video session connections with the UE2. Then the bootstrap and application data channels are established for the UE1 and UE2.
2. The split rendering negotiation procedure has been finished.
3. MF/MRF prepares the scene description based on media descriptions and assets for the call.
4. MF/MRF delivers the scene description to the UEs.
5. A UE may trigger a scene update e.g., when a new object is added/removed in the scene, or a spatial information update is sent or UE capabilities change. The figure shows the update is triggered by UE1, but this can be either UE.
6. The MF/MRF will process the new information and creates a scene description update. It is also possible for the MF/MRF to initiate an update without an update from the UEs, for example if link conditions change.
7. MF/MRF distributes scene description update to all UEs.

NOTE: Spatial data related updates may be required for collaborative AR calls, e.g., when multiple users are physically collocated and also part of the same AR experience. The type of spatial description updates is FFS.

8. Subsequent procedures continue.

A.1.5 AR Media Processing

Figure A.1.5-1 illustrates a detailed call flow for AR media processing procedure.

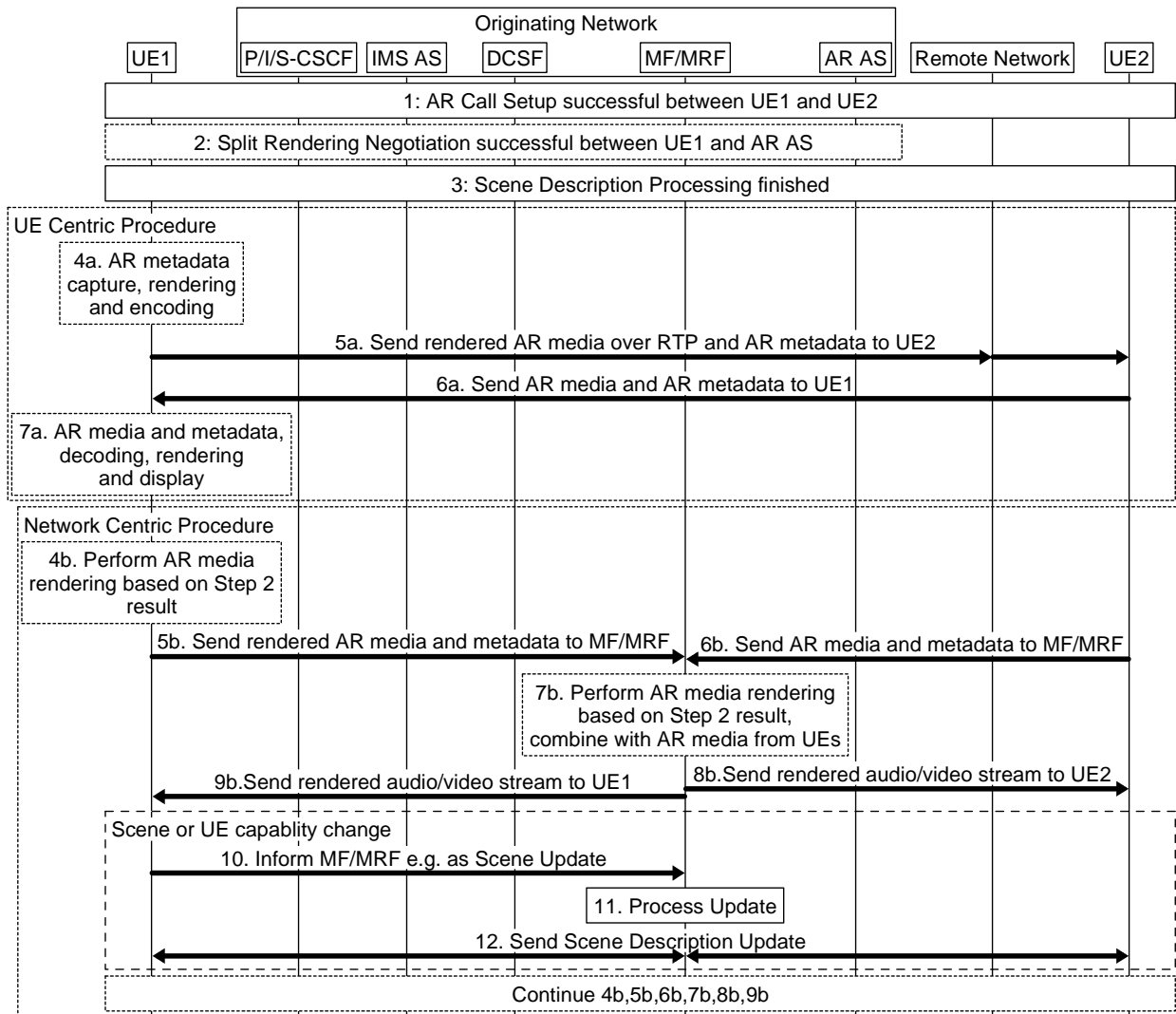

Figure A.1.5-1: Call Flow for AR Media Processing

The steps are as follows:

1. The UE1 initiates an AR communication session and establishes audio and video session connections with the UE2. Then the bootstrap and application data channels are established for the UE1 and UE2.
2. The split rendering negotiation procedure has been finished.
3. The scene description processing has been finished.
- 4a. The UE1 captures the AR metadata, performs AR media rendering locally and then encodes rendered AR media, e.g., as audio/video media stream.
- 5a. The UE1 sends the rendered AR media and/or AR metadata to the peer through the established media connection(s).
- 6a. The UE1 receives the AR media and/or AR metadata from the peer through established media connection(s).
- 7a. The UE1 decodes the AR metadata and performs AR media rendering locally and displays it on its screen.

Network Centric Procedure:

- 4b. The UE1 retrieves AR metadata such as pose and user input locally, and renders the part of AR objects that should be done in the UE1 according to the result in step 2.
- 5b. The UE1 sends AR media to the MF/MRF, the AR media can include the audio/video media stream rendered by the UE1, and the AR metadata which is used for the AR objects rendering that should be done in the IMS network.
- 6b. The UE2 may also send AR media and/or AR metadata to the MF/MRF, e.g., the viewport.
- 7b. The MF/MRF renders the part of AR objects based on the AR metadata received. Then the MF/MRF decodes the audio/video media stream received from the UE1, and combines with the AR media rendered by the MF/MRF.
- 8b. The MF/MRF sends the rendered audio/video media stream to UE2.
- 9b. The MF/MRF sends the rendered audio/video media stream to the UE1.
10. A UE may trigger a scene update as described in clause 9.1.3. for example, if objects are added/removed from the scene or if UE capabilities change and it can no longer render some AR objects as negotiated in step 2.
11. The MF/MRF processes the new information and creates a scene description update. It is also possible for the MF/MRF to initiate an update without an update from the UEs, for example if network conditions change.
12. The MF/MRF distributes the scene description update to all UEs.

Annex (informative): Change history

Change history							
Date	Meeting	TDoc	CR	Rev	Cat	Subject/Comment	New version
2022-08	SA4#120-e	S4-221017				Initial skeleton	0.0.1
2022-08	SA4#120-e	S4-221202				Version agreed during SA4#120-e	0.1.0
2023-08	SA4#125	S4-231474				Scope, references, definitions, and general descriptions	0.2.0
2023-08	SA4#125	S4-231476				Spatial description format	0.2.0
2023-11	SA4#126	S4-231783				Draft TS 26.264 v0.2.1 implemented S4aR230099 on end-to-end reference architecture and S4aR230121 on the usage of a scene	0.3.0
2023-11	SA4#126	S4-231784				Add general requirements applied both AR-MTSI and MTSI clients and remove unnecessary clauses	0.3.0
2023-11	SA4#126	S4-231785				Reuse Split Rendering Formats for session setup and negotiation and metadata defined in TS 26.565	0.3.0
2023-11	SA4#126	S4-231967				Generalized reference architecture based on IMS DC architecture in TS 23.228	0.3.0
2024-02	SA4#127	S4-240393				Agreements in SA4#127: S4-240163, S4-240165, S4-240370, S4-240323	0.4.0
2024-03	SA#103	SP-240024				Version 1.0.0 created by MCC	1.0.0
2024-04	SA4#127-bis-e	S4-240804				Agreements in SA4#127-bis-e: S4-240655, S4-240763, S4-240823	1.1.0
2024-05	SA4#128	S4-241259				Agreements in SA4#128: S4-201186, S4-241216, S4-241219, S4-241217	1.2.0
2024-06						Version 2.0.0 created by MCC	2.0.0
2024-06						Version 18.0.0 created by MCC after TSG approval	18.0.0

History

Document history		
V18.0.0	July 2024	Publication