

ETSI TS 128 536 V18.3.0 (2025-01)



**LTE;
5G;
Management and orchestration;
Management services for communication service assurance;
Stage 2 and stage 3
(3GPP TS 28.536 version 18.3.0 Release 18)**



Reference

RTS/TSGS-0528536vi30

Keywords

5G,LTE

ETSI

650 Route des Lucioles
F-06921 Sophia Antipolis Cedex - FRANCE

Tel.: +33 4 92 94 42 00 Fax: +33 4 93 65 47 16

Siret N° 348 623 562 00017 - APE 7112B
Association à but non lucratif enregistrée à la
Sous-Préfecture de Grasse (06) N° w061004871

Important notice

The present document can be downloaded from the
[ETSI Search & Browse Standards application](#).

The present document may be made available in electronic versions and/or in print. The content of any electronic and/or print versions of the present document shall not be modified without the prior written authorization of ETSI. In case of any existing or perceived difference in contents between such versions and/or in print, the prevailing version of an ETSI deliverable is the one made publicly available in PDF format on [ETSI deliver repository](#).

Users should be aware that the present document may be revised or have its status changed, this information is available in the [Milestones listing](#).

If you find errors in the present document, please send your comments to the relevant service listed under [Committee Support Staff](#).

If you find a security vulnerability in the present document, please report it through our [Coordinated Vulnerability Disclosure \(CVD\)](#) program.

Notice of disclaimer & limitation of liability

The information provided in the present deliverable is directed solely to professionals who have the appropriate degree of experience to understand and interpret its content in accordance with generally accepted engineering or other professional standard and applicable regulations.

No recommendation as to products and services or vendors is made or should be implied.

No representation or warranty is made that this deliverable is technically accurate or sufficient or conforms to any law and/or governmental rule and/or regulation and further, no representation or warranty is made of merchantability or fitness for any particular purpose or against infringement of intellectual property rights.

In no event shall ETSI be held liable for loss of profits or any other incidental or consequential damages.

Any software contained in this deliverable is provided "AS IS" with no warranties, express or implied, including but not limited to, the warranties of merchantability, fitness for a particular purpose and non-infringement of intellectual property rights and ETSI shall not be held liable in any event for any damages whatsoever (including, without limitation, damages for loss of profits, business interruption, loss of information, or any other pecuniary loss) arising out of or related to the use of or inability to use the software.

Copyright Notification

No part may be reproduced or utilized in any form or by any means, electronic or mechanical, including photocopying and microfilm except as authorized by written permission of ETSI.

The content of the PDF version shall not be modified without the written authorization of ETSI.

The copyright and the foregoing restriction extend to reproduction in all media.

© ETSI 2025.
All rights reserved.

Intellectual Property Rights

Essential patents

IPRs essential or potentially essential to normative deliverables may have been declared to ETSI. The declarations pertaining to these essential IPRs, if any, are publicly available for **ETSI members and non-members**, and can be found in ETSI SR 000 314: "*Intellectual Property Rights (IPRs); Essential, or potentially Essential, IPRs notified to ETSI in respect of ETSI standards*", which is available from the ETSI Secretariat. Latest updates are available on the [ETSI IPR online database](#).

Pursuant to the ETSI Directives including the ETSI IPR Policy, no investigation regarding the essentiality of IPRs, including IPR searches, has been carried out by ETSI. No guarantee can be given as to the existence of other IPRs not referenced in ETSI SR 000 314 (or the updates on the ETSI Web server) which are, or may be, or may become, essential to the present document.

Trademarks

The present document may include trademarks and/or tradenames which are asserted and/or registered by their owners. ETSI claims no ownership of these except for any which are indicated as being the property of ETSI, and conveys no right to use or reproduce any trademark and/or tradename. Mention of those trademarks in the present document does not constitute an endorsement by ETSI of products, services or organizations associated with those trademarks.

DECT™, **PLUGTESTS™**, **UMTS™** and the ETSI logo are trademarks of ETSI registered for the benefit of its Members. **3GPP™**, **LTE™** and **5G™** logo are trademarks of ETSI registered for the benefit of its Members and of the 3GPP Organizational Partners. **oneM2M™** logo is a trademark of ETSI registered for the benefit of its Members and of the oneM2M Partners. **GSM®** and the GSM logo are trademarks registered and owned by the GSM Association.

Legal Notice

This Technical Specification (TS) has been produced by ETSI 3rd Generation Partnership Project (3GPP).

The present document may refer to technical specifications or reports using their 3GPP identities. These shall be interpreted as being references to the corresponding ETSI deliverables.

The cross reference between 3GPP and ETSI identities can be found at [3GPP to ETSI numbering cross-referencing](#).

Modal verbs terminology

In the present document "**shall**", "**shall not**", "**should**", "**should not**", "**may**", "**need not**", "**will**", "**will not**", "**can**" and "**cannot**" are to be interpreted as described in clause 3.2 of the [ETSI Drafting Rules](#) (Verbal forms for the expression of provisions).

"**must**" and "**must not**" are **NOT** allowed in ETSI deliverables except when used in direct citation.

Contents

Intellectual Property Rights	2
Legal Notice	2
Modal verbs terminology.....	2
Foreword.....	5
Introduction	6
1 Scope	7
2 References	7
3 Definitions of terms, symbols and abbreviations	8
3.1 Terms.....	8
3.2 Symbols.....	8
3.3 Abbreviations	8
4 Communication service assurance service	8
4.1 Stage 2	8
4.1.1 Void	8
4.1.2 Model.....	8
4.1.2.1 Imported and associated information entities.....	8
4.1.2.1.1 Imported information entities and local labels	8
4.1.2.1.2 Associated information entities and local labels.....	8
4.1.2.2 Class diagram.....	9
4.1.2.2.1 Relationships.....	9
4.1.2.2.2 Inheritance.....	10
4.1.2.3 Class definitions	10
4.1.2.3.1 AssuranceClosedControlLoop	10
4.1.2.3.2 AssuranceGoal	11
4.1.2.3.3 Void.....	12
4.1.2.3.4 Void.....	12
4.1.2.3.5 AssuranceTarget <<dataType>>	12
4.1.2.3.6 AssuranceGoalStatus <<dataType>>.....	12
4.1.2.3.7 AssuranceTargetStatus <<dataType>>.....	13
4.1.2.3.8 AssuranceReport <<IOC>>	13
4.1.2.3.9 AssuranceScope <<dataType>>.....	14
4.1.2.3.10 ACCLDisallowedAttributes <<datatype>>.....	14
4.1.2.4 Attribute definitions	15
4.1.2.4.1 Attribute properties.....	15
4.1.2.4.2 Constraints.....	19
4.1.2.4.3 Notifications	20
4.1.2.5 Common notifications.....	20
4.1.2.5.1 Alarm notifications	20
4.1.2.5.2 Configuration notifications.....	20
4.1.3 Procedures.....	21
4.1.3.1 SLS Assurance Procedure	21
4.2 Stage 3	22
4.2.1 Solution Set (SS) for JSON/YAML.....	22
Annex A (informative): Control loop deployed in different layers	23
A.1 Introduction	23
A.2 Control loop in communication service layer.....	23
A.3 Control loop in network slice layer	23
A.4 Control loop in network slice subnet layer.....	24
A.5 Control loop in NF layer	24
Annex B (normative): OpenAPI definition of the COSLA NRM.....	25

B.1	General	25
B.2	Solution Set (SS) definitions	25
B.2.1	OpenAPI document " TS28536_CoslaNrm . yml "	25
Annex C (normative):	AssuranceClosedControlLoop state management	26
Annex D (informative):	Appendix with UML code for model diagrams.....	28
D.1	UML code for Figure 4.1.2.2.1.1	28
D.2	UML code for Figure 4.1.2.2.2.1	28
Annex E (informative):	Change history	30
History		33

Foreword

This Technical Specification has been produced by the 3rd Generation Partnership Project (3GPP).

The contents of the present document are subject to continuing work within the TSG and may change following formal TSG approval. Should the TSG modify the contents of the present document, it will be re-released by the TSG with an identifying change of release date and an increase in version number as follows:

Version x.y.z

where:

- x the first digit:
 - 1 presented to TSG for information;
 - 2 presented to TSG for approval;
 - 3 or greater indicates TSG approved document under change control.
- y the second digit is incremented for all changes of substance, i.e. technical enhancements, corrections, updates, etc.
- z the third digit is incremented when editorial only changes have been incorporated in the document.

In the present document, modal verbs have the following meanings:

- shall** indicates a mandatory requirement to do something
- shall not** indicates an interdiction (prohibition) to do something

The constructions "shall" and "shall not" are confined to the context of normative provisions, and do not appear in Technical Reports.

The constructions "must" and "must not" are not used as substitutes for "shall" and "shall not". Their use is avoided insofar as possible, and they are not used in a normative context except in a direct citation from an external, referenced, non-3GPP document, or so as to maintain continuity of style when extending or modifying the provisions of such a referenced document.

- should** indicates a recommendation to do something
- should not** indicates a recommendation not to do something
- may** indicates permission to do something
- need not** indicates permission not to do something

The construction "may not" is ambiguous and is not used in normative elements. The unambiguous constructions "might not" or "shall not" are used instead, depending upon the meaning intended.

- can** indicates that something is possible
- cannot** indicates that something is impossible

The constructions "can" and "cannot" are not substitutes for "may" and "need not".

- will** indicates that something is certain or expected to happen as a result of action taken by an agency the behaviour of which is outside the scope of the present document
- will not** indicates that something is certain or expected not to happen as a result of action taken by an agency the behaviour of which is outside the scope of the present document
- might** indicates a likelihood that something will happen as a result of action taken by some agency the behaviour of which is outside the scope of the present document

might not indicates a likelihood that something will not happen as a result of action taken by some agency the behaviour of which is outside the scope of the present document

In addition:

is (or any other verb in the indicative mood) indicates a statement of fact

is not (or any other negative verb in the indicative mood) indicates a statement of fact

The constructions "is" and "is not" do not indicate requirements.

Introduction

The present document describes closed control loop assurance solution enabling a service provider or an operator to continuously deliver the requested level of communication service quality to the customer and is part of a TS-family covering the 3rd Generation Partnership Project Technical Specification Group Services and System Aspects Management and orchestration of networks, as identified below:

TS 28.535: Management Services for Communication Service Assurance; Requirements

TS 28.536: Management Services for Communication Service Assurance; Stage 2 and stage 3

The solution described builds upon the management services specifications as identified below:

TS 28.530: Management and orchestration; Concepts, use cases and requirements

TS 28.533: Management and orchestration; Architecture framework

TS 28.532: Management and orchestration; Generic management services.

TS 28.540: Management and orchestration; 5G Network Resource Model (NRM); Stage 1

TS 28.541: Management and orchestration; 5G Network Resource Model (NRM); Stage 2 and stage 3

TS 28.531: Management and orchestration; Provisioning

TS 28.111: Management and orchestration; Fault Management (FM)

TS 28.550: Management and orchestration; Performance assurance

TS 28.552: Management and orchestration; 5G performance measurements

TS 28.554: Management and orchestration; 5G End to end Key Performance Indicators (KPI)

1 Scope

The present document describes the management services for communication service assurance and specifies stage 2 and stage 3 for closed control loop communication service assurance solution that adjusts and optimizes the services provided by NG-RAN and 5GC.

2 References

The following documents contain provisions which, through reference in this text, constitute provisions of the present document.

- References are either specific (identified by date of publication, edition number, version number, etc.) or non-specific.
- For a specific reference, subsequent revisions do not apply.
- For a non-specific reference, the latest version applies. In the case of a reference to a 3GPP document (including a GSM document), a non-specific reference implicitly refers to the latest version of that document *in the same Release as the present document*.

- [1] 3GPP TR 21.905: "Vocabulary for 3GPP Specifications".
- [2] Void
- [3] 3GPP TS 28.550: "Management and orchestration; Performance assurance".
- [4] Void
- [5] 3GPP TS 28.622: "Telecommunication management; Generic Network Resource Model (NRM) Integration Reference Point (IRP); Information Service (IS)".
- [6] 3GPP TS 28.541: "Management and orchestration; 5G Network Resource Model (NRM); Stage 2 and stage 3".
- [7] 3GPP TS 28.532: "Management and orchestration; Generic management services".
- [8] 3GPP TS 32.302: "Telecommunication management; Configuration Management (CM); Notification Integration Reference Point (IRP); Information Service (IS)".
- [9] Void
- [10] 3GPP TS 32.160: "Management and orchestration; Management service template".
- [11] 3GPP TS 29.520: "5G System; Network Data Analytics Services; Stage 3".
- [12] Void
- [13] Void
- [14] 3GPP TS 28.625: "State Management Data Definition Integration Reference Point (IRP); Information Service (IS)".
- [15] ITU-T Recommendation X.731: "Information technology - Open Systems Interconnection - Systems Management: State management function".
- [16] Void
- [17] 3GPP TS 28.535: "Management and orchestration; Management services for communication service assurance; Requirements".
- [18] Void.
- [19] 3GPP TS 28.111: "Fault management".

3 Definitions of terms, symbols and abbreviations

3.1 Terms

For the purposes of the present document, the terms given in TR 21.905 [1] and the following apply. A term defined in the present document takes precedence over the definition of the same term, if any, in TR 21.905 [1].

3.2 Symbols

Void.

3.3 Abbreviations

For the purposes of the present document, the abbreviations given in TR 21.905 [1] and the following apply. An abbreviation defined in the present document takes precedence over the definition of the same abbreviation, if any, in TR 21.905 [1].

COSLA	Closed control loop SLS Assurance
CSC	Communication Service Customer
CSP	Communication Service Provider
IOC	Information Object Class
JSON	JavaScript Object Notation
YAML	YAML Ain't Markup Language
MDAS	Management Data Analytics Service
MnS	Management Service
NF	Network Function
NSSI	NetworkSlice Subnet Instance
NWDAF	NetWork Data Analytics Function
SLS	Service Level Specification

4 Communication service assurance service

4.1 Stage 2

4.1.1 Void

4.1.2 Model

4.1.2.1 Imported and associated information entities

4.1.2.1.1 Imported information entities and local labels

Label reference	Local label
TS 28.622 [5], IOC, Top	Top

4.1.2.1.2 Associated information entities and local labels

Label reference	Local label
TS 28.622 [5], IOC, SubNetwork	SubNetwork
TS 28.541 [6], IOC, NetWorkSlice	NetworkSlice
TS 28.541 [6], IOC, NetWorkSliceSubnet	NetworkSliceSubnet
TS 28.622 [5], IOC, ManagedElement	ManagedElement
TS 28.541 [6], attribute, serviceProfileId	serviceProfileId
TS 28.541 [6], attribute, sliceProfileId	sliceProfileId
TS 28.541 [6], attribute, taiList	taiList

4.1.2.2 Class diagram

4.1.2.2.1 Relationships

This clause depicts the set of classes that encapsulates the information relevant for this MnS. This clause provides an overview of the relationships between relevant classes in UML. This clause provides an overview of the relationships between relevant classes in UML. Subsequent clauses provide more detailed specification of various aspects of these classes.

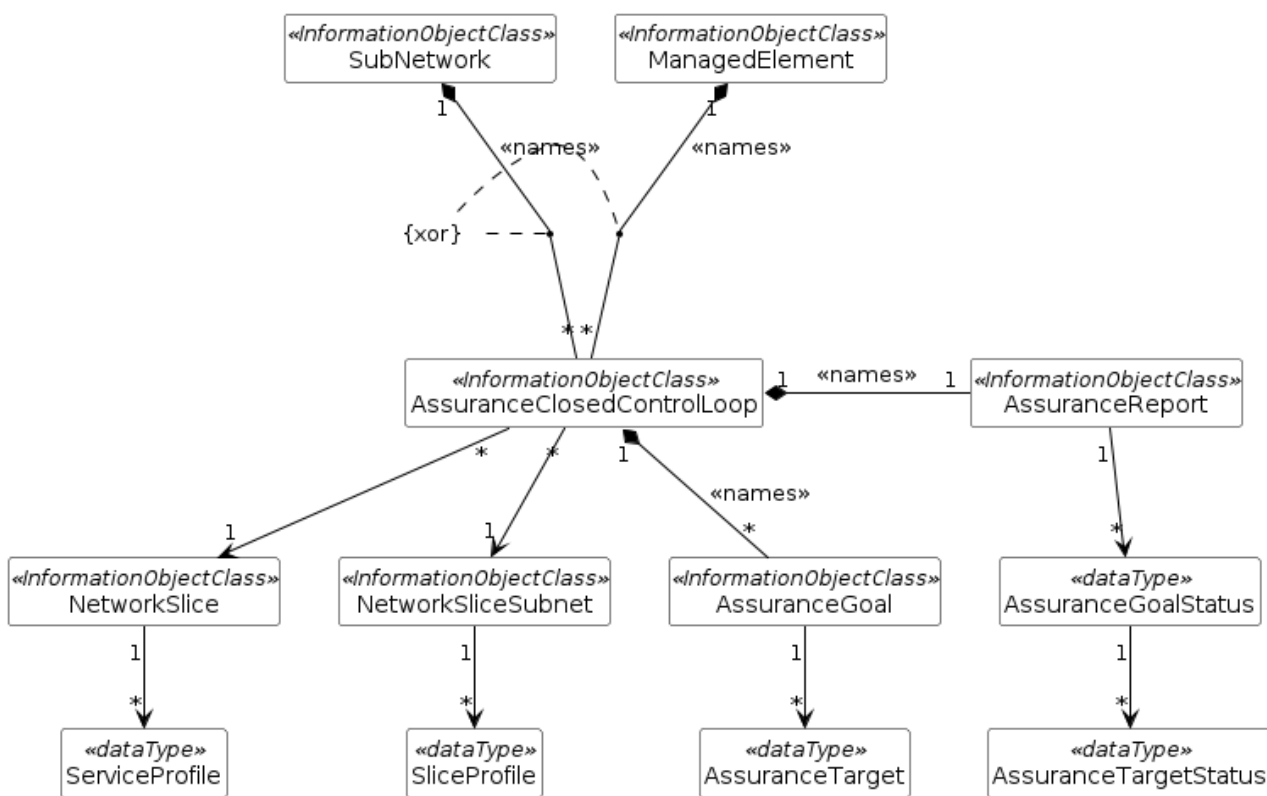

Figure 4.1.2.2.1.1: Assurance management NRM fragment

4.1.2.2.2 Inheritance

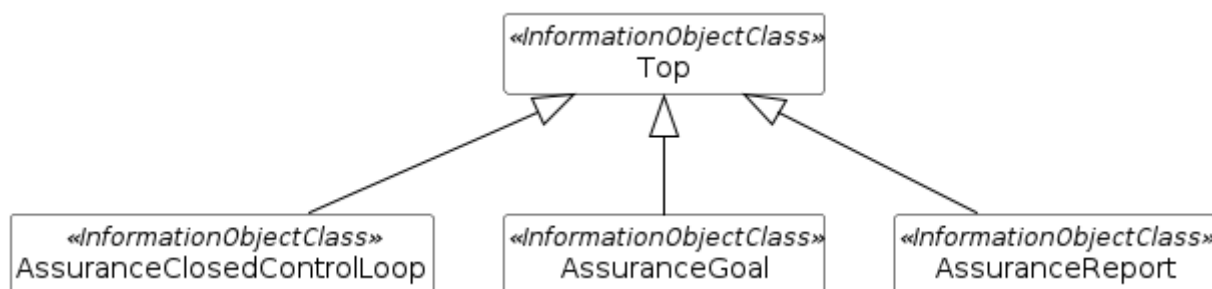

Figure 4.1.2.2.1: Assurance management inheritance relationships

4.1.2.3 Class definitions

4.1.2.3.1 AssuranceClosedControlLoop

4.1.2.3.1.1 Definition

This class represents the information for controlling and monitoring an assurance closed control loop associated with a `NetworkSlice` or `NetworkSliceSubnet`. It can be name-contained by `SubNetwork` or `ManagedElement`.

To express the assurance closed control loop goals, the MnS consumer needs to request the MnS producer to create an `AssuranceClosedControlLoop` on the MnS producer. The MnS producer may trigger to create the `AssuranceClosedControlLoop` as well, for example, when an instance of `NetworkSlice` or `NetworkSliceSubnet` is created, MnS producer may create an instance of `AssuranceClosedControlLoop` associated to the instance of `NetworkSlice` or `NetworkSliceSubnet` to assure the target described in `ServiceProfile` or `SliceProfile`. For the deletion of the assurance closed control loop, the MnS consumer needs to request the MnS producer to delete the `AssuranceClosedControlLoop` to free up resources on the MnS producer. MnS producer also can trigger to delete `AssuranceClosedControlLoop` to free up resources by itself.

For temporary deactivation of the assurance closed control loop, the MnS consumer can modify the value of the administrative state attribute to "LOCKED". The MnS producer may disable the assurance closed control loop, for example in conflict situations, by setting the operational state attribute to "disabled". When a closed control loop is enabled by the MnS producer, the operational state is set again to "enabled". For the activation of an assurance closed control loop, the MnS consumer can modify the value of the administrative state attribute to "UNLOCKED".

An `AssuranceClosedControlLoop` can name-contain multiple instances of `AssuranceGoal` which represents the assurance goal and corresponding observed or predicted goal fulfilment information (see clause 4.1.2.3.2). The `AssuranceGoal` may optionally include an assurance scope in terms of location (see clause 4.1.2.3.2).

The attribute "controlLoopLifeCyclePhase" is used to keep track of the lifecycle of an `AssuranceClosedControlLoop`.

The attribute `aCLDisallowedList` is used to descope the ACCL.-See clause 6.1.6 of TS 28.535 [17]. Each entry in the list indicates a specific list of attributes belonging to a managedEntity identified by the `managedEntityIdentifier` which the ACCL is not allowed to modify.

4.1.2.3.1.2 Attributes

The `AssuranceClosedControlLoop` IOC includes attributes inherited from Top IOC (defined TS 28.622[5]) and the following attributes:

Attribute name	S	isReadable	isWritable	isInvariant	isNotifiable
operationalState	M	T	F	F	T
administrativeState	M	T	T	F	T
controlLoopLifeCyclePhase	M	T	T	F	T
aCCLDisallowedList	O	T	T	F	T
Attributes related to role					
networkSliceRef	CM	T	T	F	T
networkSliceSubnetRef	CM	T	T	F	T

4.1.2.3.1.3 Constraints

Name	Definition
networkSliceSubnetRef	Condition: the AssuranceGoal applies to a NetworkSliceSubNet
networkSliceRef	Condition: the AssuranceGoal applies to a NetworkSlice

4.1.2.3.1.4 Notifications

The common notifications defined in clause 4.1.2.5 are valid for this IOC, without exceptions or additions.

4.1.2.3.2 AssuranceGoal

4.1.2.3.2.1 Definition

This IOC represents assurance goal.

To express a new assurance goal for the assurance closed control loop, the MnS consumer needs to request the MnS producer to create an instance of AssuranceGoal. MnS producer can also trigger the creation of an instance of AssuranceGoal. For example, when a new instance NetworkSlice or NetworkSliceSubnet is created on the MnS producer and the corresponding SLS needs to be assured, a new instance of AssuranceGoal needs to be created and associated to the new instance NetworkSlice or NetworkSliceSubnet by configuring the attributes "networkSliceRef" or "networkSliceSubnetRef" and corresponding attributes "serviceProfileId" and "sliceProfileId".

The attribute "assuranceTargetList" defines a list of assurance targets (the subset of attributes from an SLS, i.e. a ServiceProfile or a SliceProfile, that are subject to assurance requirements.) that should be assured by the AssuranceClosedControlLoop. The attribute "assuranceTargetList" is configured by MnS producer based on the specified ServiceProfile or SliceProfile.

NOTE: Multiple instances of AssuranceGoal can be created for a single instance of NetworkSlice or NetworkSliceSubnet.

4.1.2.3.2.2 Attributes

The AssuranceGoal IOC includes attributes inherited from Top IOC (defined TS 28.622[5]) and the following attributes:

Attribute name	S	isReadable	isWritable	isInvariant	isNotifiable
assuranceTargetList	M	T	F	F	T
sliceProfileId	CM	T	T	F	T
serviceProfileId	CM	T	T	F	T
observationTime	M	T	T	F	T
assuranceScope	O	T	F	F	T

4.1.2.3.2.3 Attribute constraints

Name	Definition
sliceProfileId	Condition: the AssuranceGoal applies to a NetworkSliceSubNet
serviceProfileId	Condition: the AssuranceGoal applies to a NetworkSlice

4.1.2.3.2.4 Notifications

The common notifications defined in subclause 4.1.2.5 are valid for this IOC, without exceptions or additions.

4.1.2.3.3 Void

4.1.2.3.4 Void

4.1.2.3.5 AssuranceTarget <<dataType>>

4.1.2.3.5.1 Definition

This data type represents a single attribute name-value-pair of which one or more are included in an AssuranceGoal.

4.1.2.3.5.2 Attributes

Attribute name	S	isReadable	isWritable	isInvariant	isNotifyable
assuranceTargetName	M	T	T	F	T
assuranceTargetValue	M	T	F	F	T

4.1.2.3.5.3 Attribute constraints

No constraints have been defined for this document.

4.1.2.3.5.4 Notifications

The common notifications defined in clause 4.1.2.5 are valid for the <<IOC>> using this <<dataType>> as one of its attributes, shall be applicable.

4.1.2.3.6 AssuranceGoalStatus <<dataType>>

4.1.2.3.6.1 Definition

This data type represents the observed and/or predicted AssuranceGoal fulfilment status.

To obtain the observed predicted status of the the goal fulfilment information, the MnS consumer can query the attributes "AssuranceGoalStatusObserved" and "AssuranceGoalStatusPredicted" from MnS producer. The attributes "AssuranceGoalStatusObserved" and "AssuranceGoalStatusPredicted" are configured by MnS producer at the end of an observation period. The observation period is assigned by MnS consumer through requesting the MnS producer to set attribute "observationTime". The status of the goal fulfilment is considered FULFILLED if all the constituent targets are FULFILLED.

4.1.2.3.6.2 Attributes

Attribute name	Support Qualifier	isReadable	isWritable	isInvariant	isNotifyable
assuranceGoalStatusId	M	T	F	F	T
assuranceGoalId	O	T	F	F	T
assuranceGoalStatusObserved	O	T	F	F	T
assuranceGoalStatusPredicted	O	T	F	F	T
assuranceTargetStatusList	O	T	F	F	T

4.1.2.3.6.3 Attribute constraints

No constraints have been defined for this document.

4.1.2.3.6.4 Notifications

The common notifications defined in clause 4.1.2.5 are valid for this <<IOC>> , without exceptions or additions.

4.1.2.3.7 AssuranceTargetStatus <<dataType>>

4.1.2.3.7.1 Definition

This data type represents the observed and/or predicted target fulfilment status.

To obtain the observed predicted status of the the target fulfilment information, the MnS consumer can query the attributes "AssuranceTargetStatusObserved" and "AssuranceTargetStatusPredicted" from MnS producer. The attributes "AssuranceTargetStatusObserved" and "AssuranceTargetStatusPredicted" are configured by MnS producer at the end of an observation period. The observation period is assigned by MnS consumer through requesting the MnS producer to set attribute "observationTime". The status of the target fulfilment is considered FULFILLED if all the constituent target are FULFILLED.

Attribute name	Support Qualifier	isReadable	isWritable	isInvariant	isNotifiable
assuranceTargetStatusId	M	T	F	F	T
assuranceTargetName	O	T	F	F	T
assuranceTargetStatusObserved	O	T	F	F	T
assuranceTargetStatusPredicted	O	T	F	F	T

4.1.2.3.7.3 Attribute constraints

No constraints have been defined for this document.

4.1.2.3.7.4 Notifications

The common notifications defined in clause 4.1.2.5 are valid for the <<IOC>> using this <<dataType>> as one of its attributes, shall be applicable.

4.1.2.3.8 AssuranceReport <<IOC>>

4.1.2.3.8.1 Definition

This class represents the attributes of assurance report, e.g, the information about one or multiple AssuranceGoalStatus and one or multiple AssuranceTargetStatus.

The attribute "assuranceGoalStatusList" defines a list of AssuranceGoalStatus.

AssuranceReport represents the monitoring information of an assurance closed control loop. An AssuranceReport is contained by an AssuranceClosedControlLoop. There is one AssuranceReport per assurance closed control loop for an observation time. The content of the AssuranceReport may be different for different observation time. According to the AssuranceGoal and the AssuranceReport, the consumer performs closed control loop governance as described in clause "4.2.5 Closed control loop governance and monitoring" in TS 28.535 [17].

4.1.2.3.8.2 Attributes

Attribute name	Support Qualifier	isReadable	isWritable	isInvariant	isNotifiable
assuranceGoalStatusList	O	T	F	F	T
Attributes related to role					
assuranceGoalRef	O	T	F	F	T

4.1.2.3.8.3 Attribute constraints

No constraints have been defined for this document

4.1.2.3.8.4 Notifications

The common notifications defined in subclause 4.1.2.5 are valid for this IOC, without exceptions or additions.

4.1.2.3.9 AssuranceScope <<dataType>>

4.1.2.3.9.1 Definition

It indicates the target for assurance goal in terms of location. A particular ACCL can target for a particular location. The assurance goal status is ascertained based on the appropriately collected performance measurements as per the target location.

4.1.2.3.9.2 Attributes

Attribute name	S	isReadable	isWritable	isInvariant	isNotifiable
tailList	O	T	F	F	T

4.1.2.3.9.3 Attribute constraints

No constraints have been defined for this document.

4.1.2.3.9.4 Notifications

The common notifications defined in clause 4.1.2.5 are valid for the <<IOC>> using this <<dataType>> as one of its attributes, shall be applicable.

4.1.2.3.10 ACCLDisallowedAttributes <<datatype>>

4.1.2.3.10.1 Definition

This data type represents attributes which an ACCL is not allowed to change. The first attribute "managedEntityIdentifier" identifies the DN of the SubNetwork or ManagedElement, the second attribute is a list of attributeNames of the Subnetwork or ManagedElement.

4.1.2.3.10.2 Attributes

Attribute name	Support Qualifier	isReadable	isWritable	isInvariant	isNotifiable
managedEntityIdentifier	M	T	T	F	T
attributeNameList	M	T	T	F	T

4.1.2.3.10.3 Constraints

No constraints have been defined for this document.

4.1.2.3.10.4 Notifications

The common notifications defined in clause 4.1.2.5 are valid for this IOC, without exceptions or additions.

4.1.2.4 Attribute definitions

4.1.2.4.1 Attribute properties

The following table defines the properties of attributes that are specified in the present document.

Table 4.1.2.4.1.1

Attribute Name	Documentation and Allowed Values	Properties
controlLoopLifeCyclePhase	<p>It indicates the lifecycle phase of the AssuranceClosedControlLoop instance.</p> <p>AllowedValues: PREPARATION, COMMISSIONING, OPERATION, DECOMMISSIONING.</p>	<p>type: Enum multiplicity: 1 isOrdered: N/A isUnique: N/A defaultValue: None isNullable: False</p>
assuranceTargetName	<p>The name of the attribute which is part of AssuranceTarget and AssuranceTargetStatus. The assuranceTargetName uniquely identifies the name of an AssuranceTarget instance in corresponding AssuranceTargetStatus instance.</p> <p>The assuranceTargetName shall be equal to the name of an attribute in the relevant ServiceProfile or SliceProfile. The relevant ServiceProfile or SliceProfile is identified by the attribute serviceProfileId or sliceProfileId in the AssuranceGoal.</p>	<p>type: String multiplicity: 1 isOrdered: N/A isUnique: N/A defaultValue: None isNullable: False</p>
assuranceTargetValue	<p>The value of the attribute which is part of AssuranceTarget</p>	<p>type: String multiplicity: 1 isOrdered: N/A isUnique: N/A defaultValue: None isNullable: False</p>
assuranceTargetList	<p>This is an attribute containing a list of AssuranceTarget(s) that are part of an AssuranceGoal</p>	<p>type: AssuranceTarget multiplicity: 1..* isOrdered: False isUnique: True defaultValue: None isNullable: False</p>
observationTime	<p>It indicates the observation period of assuranceGoalStatusObserved and assuranceGoalStatusPredicted.</p> <p>The assurance goal will be observed from the start of each observation period, then at the end of each observation period, the value for assuranceGoalStatusObserved and assuranceGoalStatusPredicted will be derived and configured.</p> <p>The observation time is expressed in seconds.</p>	<p>type: Integer multiplicity: 1 isOrdered: N/A isUnique: N/A defaultValue: None isNullable: False</p>
assuranceGoalStatusObserved	<p>It holds the status of the observed goal fulfilment to the assuranceGoal. The value is FULFILLED only if all the constituent assuranceTargetStatusObserved are FULFILLED.</p> <p>During the initial operation of a closed control loop no fulfilment information may be available to report, the value NO_REPORT will be used.</p> <p>allowedValues: "NO_REPORT", "FULFILLED", "NOT_FULFILLED"</p>	<p>type: ENUM multiplicity: 1 isOrdered: N/A isUnique: N/A defaultValue: None isNullable: False</p>

assuranceGoalStatusPredicted	<p>It holds the status of the predicted future goal fulfilment to the assuranceGoal . The value is FULFILLED only if all the constituent assuranceTargetStatusPredicted are FULFILLED.</p> <p>During the initial operation of a closed control loop no fulfilment information may be available to report, the value NO_REPORT will be used.</p> <p>allowedValues: "NO_REPORT", "FULFILLED", "NOT_FULFILLED".</p>	<p>type: ENUM multiplicity: 1 isOrdered: N/A isUnique: N/A defaultValue: None isNullable: False</p>
assuranceTargetStatusObserved	<p>It holds the status of the observed target fulfilment to the assuranceGoal .</p> <p>allowedValues: "FULFILLED", "NOT_FULFILLED"</p>	<p>type: ENUM multiplicity: 1 isOrdered: N/A isUnique: N/A defaultValue: None isNullable: False</p>
assuranceTargetStatusPredicted	<p>It holds the status of the predicted future target fulfilment to the assuranceGoal</p> <p>allowedValues: "FULFILLED", "NOT_FULFILLED"</p>	<p>type: ENUM multiplicity: 1 isOrdered: N/A isUnique: N/A defaultValue: None isNullable: False</p>
networkSliceRef	<p>It holds the reference to the NetworkSlice instance subject to assurance requirements</p>	<p>type: DN multiplicity: 1 isOrdered: N/A isUnique: N/A defaultValue: None isNullable: False</p>
networkSliceSubnetRef	<p>It holds the reference to the NetworkSliceSubnet instance subject to assurance requirements</p>	<p>type: DN multiplicity: 1 isOrdered: N/A isUnique: N/A defaultValue: None isNullable: False</p>
operationalState	<p>It indicates the operational state of the AssuranceClosedControlLoop instance. It describes whether the resource is installed and partially or fully operable (ENABLED) or the resource is not installed or not operable (DISABLED).</p> <p>allowedValues: "ENABLED", "DISABLED". The meaning of these values is as defined in 3GPP TS 28.625 [14] and ITU-T X.731 [15].</p>	<p>type: ENUM multiplicity: 1 isOrdered: N/A isUnique: N/A defaultValue: DISABLED isNullable: False</p>
administrativeState	<p>It indicates the administrative state of the AssuranceClosedControlLoop instance. It describes the permission to use or the prohibition against using the AssuranceClosedControlLoop instance. The administrative state is set by the MnS consumer.</p> <p>allowedValues: "LOCKED", "UNLOCKED". The meaning of these values is as defined in 3GPP TS 28.625 [14] and ITU-T X.731 [15].</p>	<p>type: ENUM multiplicity: 1 isOrdered: N/A isUnique: N/A defaultValue: LOCKED isNullable: False</p>
assuranceScope	<p>It indicates the target for assurance goal in terms of a particular location.</p> <p>Allowed values: Not Applicable</p>	<p>type: AssuranceScope multiplicity: 1 isOrdered: N/A isUnique: N/A defaultValue: None isNullable: False</p>

ManagedEntityIdentifier	The DN of a managed entity Allowed values: not applicable	Type: DN multiplicity: 0..1 isOrdered: N/A isUnique: N/A defaultValue: None isNullable: False
attributeNameList	This is a list parameter identifies a list of the attributes names of a ManagedElement or a Subnetwork identified with ManagedEntityIdentifier that are not allowed to be modified by an ACCL. Allowed values: not applicable	Type: AttributeNameList of String multiplicity: * isOrdered: False isUnique: True defaultValue: None isNullable: False
aCCLDisallowedList	This is a list of ACCLDisallowedAttributes parameter identifies the list of ManagedElement or Subnetwork identified with ManagedEntityIdentifier and corresponding attributes that are not allowed to be modified by an ACCL. Allowed values: not applicable	Type: ACCLDisallowedAttributes multiplicity: * isOrdered: False isUnique: True defaultValue: None isNullable: False
assuranceGoalStatusId	The indication of the AssuranceGoalStatus.	type: String multiplicity: 1 isOrdered: N/A isUnique: N/A defaultValue: None isNullable: False
assuranceTargetStatusId	The indication of the AssuranceTargetStatus.	type: String multiplicity: 1 isOrdered: N/A isUnique: N/A defaultValue: None isNullable: False
assuranceGoalStatusList	This is an attribute containing a list of assuranceGoalStatus	type: AssuranceGoalStatus multiplicity: 1..* isOrdered: False isUnique: True defaultValue: None isNullable: False
assuranceTargetStatusList	This is an attribute containing a list of assuranceTargetStatus	type: AssuranceTargetStatus multiplicity: 1..* isOrdered: False isUnique: True defaultValue: None isNullable: False
assuranceGoalDnId	It holds the identity in AssuranceGoalStatus that uniquely identifies the corresponding Dn of the AssuranceGoal instance for which the assuranceGoalStatus applies	type: DN multiplicity: 1 isOrdered: N/A isUnique: N/A defaultValue: None isNullable: False
NOTE 1: Void NOTE 2: Void		

4.1.2.4.2 Constraints

No constraints have been identified for this document.

4.1.2.4.3 Notifications

This subclause presents a list of notifications, defined in TS 28.532 [7], that provisioning management service consumer can receive. The notification parameter `objectClass/objectInstance`, defined in TS 32.160 [10], would capture the DN of an instance of an IOC defined in the present document.

4.1.2.5 Common notifications

4.1.2.5.1 Alarm notifications

This clause presents a list of notifications, defined in TS 28.111 [19], that an MnS consumer may receive. The notification header attribute `objectClass/objectInstance`, defined in TS 32.302 [8], shall capture the DN of an instance of a class defined in the present document.

Name	Qualifier	Notes
<code>notifyNewAlarm</code>	M	--
<code>notifyClearedAlarm</code>	M	--
<code>notifyAckStateChanged</code>	M	--
<code>notifyAlarmListRebuilt</code>	M	--
<code>notifyChangedAlarm</code>	O	--
<code>notifyCorrelatedNotificationChanged</code>	O	--
<code>notifyChangedAlarmGeneral</code>	O	--
<code>notifyComments</code>	O	--
<code>notifyPotentialFaultyAlarmList</code>	O	--

4.1.2.5.2 Configuration notifications

This clause presents a list of notifications, defined in TS 28.532 [7], that an MnS consumer may receive. The notification header attribute `objectClass/objectInstance`, defined in TS 32.302 [8], shall capture the DN of an instance of a class defined in the present document.

Name	Qualifier	Notes
<code>notifyMOICreation</code>	O	--
<code>notifyMOIDeletion</code>	O	--
<code>notifyMOIAttributeValueChanges</code>	O	--
<code>notifyMOIChanges</code>	O	--
<code>notifyEvent</code>	O	--

4.1.3 Procedures

4.1.3.1 SLS Assurance Procedure

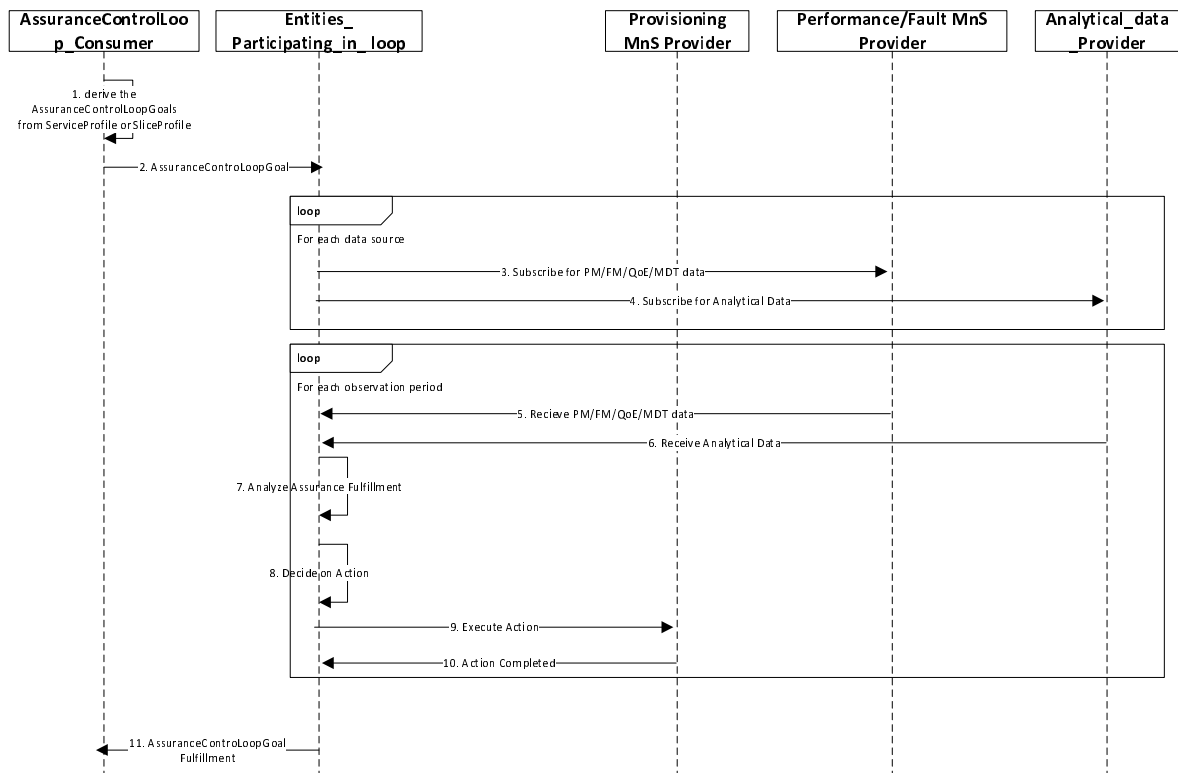

Figure 4.1.3.1.1 SLS assurance procedure

For the purpose of the procedure shown in Figure 4.1.3.1.1 "entities participating in the loop" refers to any entity in the 3GPP management system responsible for the functioning of an ACCL to ensure the AssuranceControlLoopGoal required by an AssuranceControlLoop_Consumer.

1. AssuranceControlLoop_consumer derives AssuranceControlLoopGoal from the ServiceProfile or SliceProfile.
2. AssuranceControlLoop_consumer provides the AssuranceControlLoopGoal to Entities_Participating_in_loop by utilizing the provision management services defined in as defined in clause 11.1.1.3 of TS 28.532 [7].

NOTE 1: In case the Entities_Participating_in_loop represents CrossDomain_Entities_Participating_in_loop, the AssuranceControlLoopGoal is the attribute(s) of the ServiceProfile. In case the Entities_Participating_in_loop represents Domain_Entities_Participating_in_loop, the AssuranceControlLoopGoal is the attribute(s) of the SliceProfile.

3. Entities_Participating_in_loop subscribes the related performance data (e.g., the packet delay related measurements), fault data, QoE data (e.g., buffer level) and MDT data from respective sources by utilizing the Operation establishStreamingConnection as defined in clause 11.5.1.1 of TS 28.532 [7].
4. Entities_Participating_in_loop, optionally, subscribes the related analytical data from MDAS producer or network functions, e.g., NWDAF. In case of NWDAF as a provider, Nnwdaf_EventsSubscription Service as defined in clause 4.2 of TS 29.520 [11] is used.
5. Entities_Participating_in_loop collects the related performance, fault, QoE and MDT data (e.g., the packet delay related measurements), fault data, QoE data (e.g., buffer level) and MDT data from respective sources by utilizing the Operation reportStreamData as defined in clause 11.5.1.3 of TS 28.550 [3].
6. Entities_Participating_in_loop, optionally, collects the related analytical data from MDAS producer or network functions, e.g., NWDAF. In case of NWDAF as a provider, Nnwdaf_AnalyticsInfo Service as defined in clause 4.3 of TS 29.520 [11] is used.

7. Entities_Participating_in_loop assesses if the AssuranceControlLoopGoal has been fulfilled.
 8. Entities_Participating_in_loop assesses if and which action to take in case the AssuranceControlLoopGoal has not been fulfilled.
 9. As per the mitigation action (e.g., scale out) resources are changed, the generic provisioning management service as defined in clause 11.1 of TS 28.532 [7] is utilized for the same.
 10. Action completed.
- NOTE 2: The Entities_Participating_in_loop continues to monitor and analyse the performance and perform the adjustment until the attribute(s) of SliceProfile is assured.
11. AssuranceControlLoop_consumer receives the confirmation of assurance fulfilment from Entities_Participating_in_loop by utilizing the provision management services defined in clause 11.1.1.3 of TS 28.532 [7].

4.2 Stage 3

4.2.1 Solution Set (SS) for JSON/YAML

The OpenAPI/YAML definitions are specified in 3GPP Forge, refer to clause 4.3 of TS 28.623 [x] for the Forge location. An example of Forge location is: "https://forge.3gpp.org/rep/sa5/MnS/-/tree/Tag_Rel18_SA104/".

Directory: OpenAPI

File: TS28536_CoslaNrm.yaml

Annex A (informative): Control loop deployed in different layers

A.1 Introduction

This example gives a high-level view of control loops deployed in different layers, which consists of control loop in communication service layer, control loop in network slice layer, control loop in network slice subnet layer and control loop in NF layer, as described as Figure A.1.1, where the analytic could be leverage MDAS, and different control loops can provide input (interact with) to other control loops (in the same layer or different layers) and obtain the output from other control loops (in the same layer or different layers).

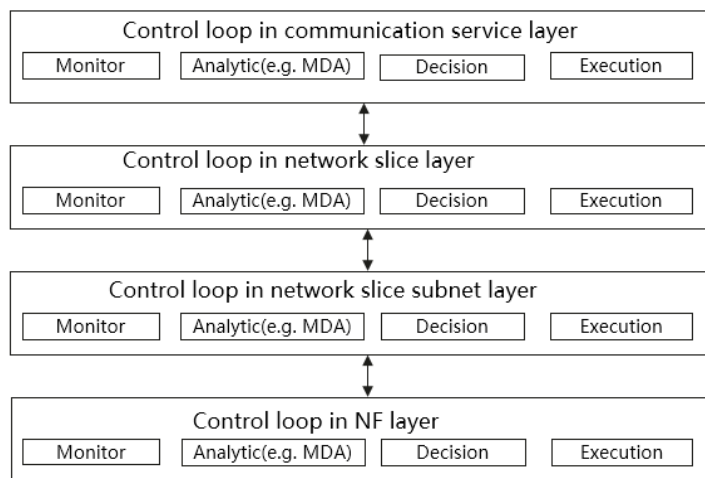

Figure A.1.1: Control loop in different layers

A.2 Control loop in communication service layer

SLA/SLS requirements provided from CSC are translated into serviceProfile, which represents the requirements for communication service assurance to the CSP. Coordination between control loop in communication service layer and control loop in network slice layer is needed to calculate the communication service resource requirements and to assure the communication service SLA/SLS requirements.

When the communication service is active, network slice performance is monitored and analysed for the communication service according to end user service experiences.

If service degradation occurs or it is predicted, the 3GPP management system could take actions, i.e. the allocated resources are scaled up or the SLS is adjusted based on pre-agreement/interaction between CSP and CSC.

A.3 Control loop in network slice layer

After receiving SLA/SLS requirements from service profile and completing the network slice provisioning, the network slice performance (e.g. KPI, QoE) are monitored and reported. Compared to the SLA/SLS requirements from service profile, when network slice performance is not met, the 3GPP management system identifies the root cause and may reconfigure the resources according to analytical report from MDAS producer. The network slice resources are also modified accordantly in case the network slice performance requirement needs to be changed based on communication service requirement adjustment.

A.4 Control loop in network slice subnet layer

After decomposing service profile to slice profile, the performance requirements for each network slice subnet are obtained. The 3GPP management system could have the capability of service observation (e.g., the supervision to the NSSI) based on MDAS. Based on such observation and comparison with initial subnet performance requirements, management actions on the NSSI might be performed if NSSI performance requirements fulfillment indicates a problem. Another possible scenario is that, when the NSSI performance requirement is changed because of the network slice modification management action, the NSSI resources might be also reconfigured.

A.5 Control loop in NF layer

NOTE: The control loop in NF layer is not addressed in the present document.

Annex B (normative): OpenAPI definition of the COSLA NRM

B.1 General

This annex contains the OpenAPI definition of the COSLA NRM in YAML format.

The Information Service (IS) of the COSLA NRM is defined in clause 4.

Mapping rules to produce the OpenAPI definition based on the IS are defined in TS 32.160 [10].

B.2 Solution Set (SS) definitions

B.2.1 OpenAPI document " TS28536_CoslaNrm.yaml "

Note that clause 4.2.1 includes the location of TS28536_CoslaNrm.yaml.

Annex C (normative): AssuranceClosedControlLoop state management

An AssuranceClosedControlLoop is a logical object in the management system that represents complex interaction between the assurance information and configuration information of a grouping of resources. At any time, the management system needs to know the state of an AssuranceClosedControlLoop.

The ITU-T X.731 [15], to which TS 28.625 [14] refers, has defined the inter-relation between the administrative state and operational state of systems in general. Figure X.1 shows the state diagram of an AssuranceClosedControlLoop, where the number in the Figure identify the state changes. The explanations for the state changes are described in Table C.1.

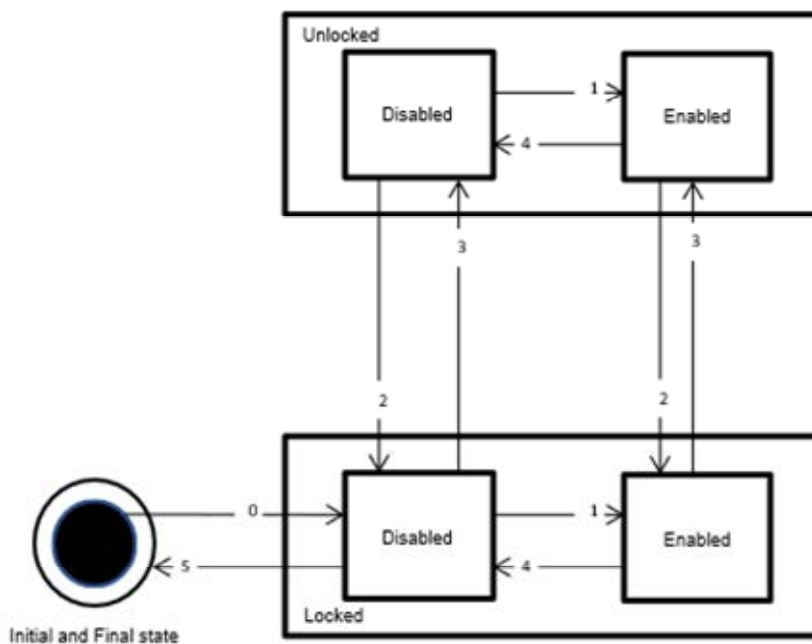

Figure C.1: AssuranceClosedControlLoop state diagram

In an AssuranceClosedControlLoop deployment scenario, the interactions between various management services allow the reconfiguration of the resources controlled by the AssuranceClosedControlLoop based on predefined goal(s). The interactions specified under the column "The state transition events and actions" of Table C.1 shall be present for the state transition.

Table C.1: The AssuranceClosedControlLoop state transition table

Trigger number	The state transition events and actions	State
0	The Assurance MnS producer responds positively to the "create ACCL" message, the ACCL is created and the state is set to Locked	Locked & Disabled
1	The Assurance MnS producer has assurance goals to fulfil and starts or resumes operation by setting the operational state to Enabled	Locked & Enabled
2	The Assurance MnS consumer suspends operation of the ACCL by setting the administrative state to Locked	Locked (Enabled or Disabled)

3	The Assurance MnS consumer resumes operation of the ACCL by setting the administrative state to Unlocked.	Unlocked (Enabled or Disabled)
4	The Assurance MnS producer does not have any assurance goals to fulfil and suspends operation by setting the operational state to Disabled	Disabled (Locked or Unlocked)
5	The Assurance MnS producer responds positively to the "delete ACCL" message, the ACCL is deleted, and the state is set to NULL (the Initial and Final state)	NULL

NOTE: The trigger numbers in the first column represent the state changes in Figure C.1

Annex D (informative): Appendix with UML code for model diagrams

D.1 UML code for Figure 4.1.2.2.1.1

```

@startuml
skinparam backgroundColor white
skinparam classBackgroundColor white
skinparam classBorderColor black
skinparam Shadowing false
skinparam noteBackgroundColor white
skinparam noteBorderColor white
skinparam arrowColor black
hide circle
hide members

class SubNetwork <<InformationObjectClass>>
class ManagedElement <<InformationObjectClass>>
class AssuranceClosedControlLoop <<InformationObjectClass>>
class AssuranceReport <<InformationObjectClass>>
class AssuranceGoal <<InformationObjectClass>>
class NetworkSlice <<InformationObjectClass>>
class NetworkSliceSubnet <<InformationObjectClass>>
class ServiceProfile <<dataType>>
class SliceProfile <<dataType>>
class AssuranceTarget <<dataType>>
class AssuranceGoalStatus <<dataType>>
class AssuranceTargetStatus <<dataType>>

SubNetwork "1" *-- "*" AssuranceClosedControlLoop: <<names>>
ManagedElement "1" *-- "*" AssuranceClosedControlLoop: <<names>>
AssuranceClosedControlLoop "1" *-- "*" AssuranceGoal: <<names>>
AssuranceReport "1" -left-* "1" AssuranceClosedControlLoop: <<names>>
AssuranceReport "1" --> "*" AssuranceGoalStatus
AssuranceGoalStatus "1" --> "*" AssuranceTargetStatus
AssuranceGoal "1" --> "*" AssuranceTarget
AssuranceClosedControlLoop "*" --> "1" NetworkSlice
NetworkSlice "1" --> "*" ServiceProfile
AssuranceClosedControlLoop "*" --> "1" NetworkSliceSubnet
NetworkSliceSubnet "1" --> "*" SliceProfile

note "{xor}" as Note1
Note1 .. (SubNetwork, AssuranceClosedControlLoop)
Note1 .. (ManagedElement, AssuranceClosedControlLoop)

@enduml

```

D.2 UML code for Figure 4.1.2.2.2.1

```

@startuml
skinparam backgroundColor white
skinparam classBackgroundColor white
skinparam classBorderColor black
skinparam Shadowing false
skinparam noteBackgroundColor white
skinparam noteBorderColor black
skinparam Note1BorderColor red
skinparam arrowColor black
hide circle
hide members

class Top <<InformationObjectClass>>
class AssuranceClosedControlLoop <<InformationObjectClass>>
class AssuranceGoal <<InformationObjectClass>>
class AssuranceReport <<InformationObjectClass>>

Top <|-- AssuranceClosedControlLoop

```

Top <|-- AssuranceGoal
Top <|-- AssuranceReport

@enduml

Annex E (informative): Change history

Change history							
Date	Meeting	TDoc	CR	Rev	Cat	Subject/Comment	New version
2020-07	SA#88e					Upgrade to change control version	16.0.0
2020-09	SA#89e	SP-200749	0001	-	F	Update control loop deployed in different layers with SLA decomposition	16.1.0
2020-09	SA#89e	SP-200750	0004	-	F	Add references to clause 4.1.2.3	16.1.0
2020-09	SA#89e	SP-200750	0005	-	F	Correct title and add references in clause 4.1.1	16.1.0
2020-09	SA#89e	SP-200750	0006	-	F	Remove Editor's Note in clause 4.1.1	16.1.0
2020-09	SA#89e	SP-200750	0007	-	F	Replace Editors Note in clause Annex A.5 with a Note	16.1.0
2020-09	SA#89e	SP-200750	0003	-	F	Add abbreviations to clause 3.3	16.1.0
2020-12	SA#90e	SP-201050	0008	-	F	Update references to other specifications	16.2.0
2020-12	SA#90e	SP-201056	0011	-	F	Update and make closed control loop term consistent	16.2.0
2020-12	SA#90e	SP-201056	0013	-	F	Add Annex on state management	16.2.0
2020-12	SA#90e	SP-201056	0016	-	F	Implement Assurance Closed Loop model changes	16.2.0
2020-12	SA#90e					Correction in history table of SP numbers	16.2.1
2021-03	SA#91e	SP-210151	0017	-	F	Remove conflicting attribute definitions	16.3.0
2021-03	SA#91e	SP-210151	0018	-	F	Clarify modelling of AssuranceGoal	16.3.0
2021-03	SA#91e	SP-210151	0019	3	F	Correct OpenAPI definition of the COSLA NRM	16.3.0
2021-03	SA#91e	SP-210151	0022	-	F	Remove overview from stage 2 description	16.3.0
2021-03	SA#91e	SP-210151	0025	2	F	Correct the misalignment information for COSLA NRM	16.3.0
2021-03	SA#91e	SP-210151	0027	1	F	Add explanation of entities in closed loop	16.3.0
2021-06	SA#92e	SP-210405	0028	-	C	Moving Assurance Observed and Predicted	17.0.0
2021-06	SA#92e	SP-210405	0029	-	B	Improve the readability of closed control loop NRM fragment	17.0.0
2021-12	SA#94e	SP-211469	0035	1	B	Focused ACCL	17.1.0
2021-12	SA#94e	SP-211469	0036	1	F	Update the definition for attribute observationTime	17.1.0
2022-03	SA#95e	SP-220174	0037	1	F	Editorial on the definition of AssuranceClosedControlLoop	17.2.0
2022-03	SA#95e	SP-220174	0038	1	F	Fixing the S qualifier	17.2.0
2022-03	SA#95e	SP-220174	0039	-	B	Add with code of UML model diagrams	17.2.0
2022-06	SA#96	SP-220497	0046	-	A	Fixing OpenAPI Discoverability issue in CoslaNrm.yaml stage 3	17.3.0
2022-06	SA#96	SP-220497	0048	-	A	OpenAPI file name and dependence change for coslaNrm.yaml	17.3.0
2022-06	SA#96	SP-220503	0049	-	C	DraftCR fro TS 28.536	17.3.0
2022-06	SA#96	SP-220503	0050	1	B	Add solution for disabling CL	17.3.0
2022-06	SA#96	SP-220504	0052	-	A	Minor correction on the format for cosla.yaml file	17.3.0
2022-06	SA#96	SP-220504	0054	-	A	Correct attribute properties of assuranceTargetList	17.3.0
2022-06	SA#96					CR implementation errors corrections	17.3.1
2022-09	SA#97e	SP-220860	0056	1	F	Add missing tags in stage 3	17.4.0
2022-09	SA#97e					Alignment with FORGE code	17.4.1
2023-09	SA#99	SP-230196	0057	-	F	Adding missing assuranceScope in AssuranceGoal	17.5.0
2023-09	SA#101	SP-230944	0058	1	F	Rel-17 CR for TS28.536 Fix isWritable property of assuranceScope in AssuranceGoal	17.6.0
2023-09	SA#101	SP-230944	0059	1	F	Rel-17 CR for TS28.536 Fix wrong clauses numbering in class definitions	17.6.0
2023-09	SA#101	SP-230940	0061	1	A	Rel-17 CR for TS28.536 Fix ambiguous description in SLS Assurance Procedure	17.6.0
2023-12	SA#102	SP-231490	0064	-	F	Fix the properties of attributes	17.7.0
2023-12	SA#102	SP-231490	0065	1	F	Correction of attribute properties	17.7.0
2024-03	SA#103	SP-240186	0066	-	F	TS28.536 Rel18 correction to Schema definition Issues for SubNetwork and ManagedElement of OpenAPI SS	18.0.0
2024-06	SA#104	SP-240808	0067	1	F	Rel-18 CR 28.536 Remove 28-545 reference	18.1.0
2024-06	SA#104	SP-240803	0072		A	Rel-18 CR TS 28.536 correction of attribute definition	18.1.0
2024-06	SA#104	SP-240812	0075	1	A	Rel-18 CR TS 28.536 Correct issues for assurance management NRM fragment	18.1.0
2024-06	SA#104	SP-240808	0076		F	TS28.536 Rel18 remove MnS root in stage 3-yaml and Moving normative stage 3 to Forge	18.1.0
2024-06	SA#104	SP-240803	0078	1	A	CR Rel-18 TS 28.536 Correct dataType name in Figure 4.1.2.2.1.1	18.1.0
2024-06	SA#104	SP-240803	0080	1	A	CR Rel-18 TS 28.536 Remove editors notes	18.1.0
2024-09	SA#105	SP-241179	0089	1	F	Rel-18 CR TS 28.536 Correction of reference to Alarm Notification	18.2.0

2024-09	SA#105	SP-241166	0095	1	A	Rel-18 CR TS 28.536 Fix stage 3 assurance report containment by an ACCL	18.2.0
2024-12	SA#106	SP-241635	0102	-	A	Rel-18 CR TS 28.536 Fix issues in SLS Assurance Procedure	18.3.0
2024-12	SA#106	SP-241633	0110	-	A	Rel-18 CR 28.536 Fix mismatch between stage 2 and stage 3	18.3.0

History

Document history		
V18.0.0	May 2024	Publication
V18.1.0	July 2024	Publication
V18.2.0	October 2024	Publication
V18.3.0	January 2025	Publication