

ETSI TS 128 561 V19.1.1 (2026-02)



TECHNICAL SPECIFICATION

**5G;
Management and orchestration;
Management aspects of Network Digital Twins
(3GPP TS 28.561 version 19.1.1 Release 19)**



Reference

RTS/TSGS-0528561vj11

Keywords

5G

ETSI

650 Route des Lucioles
F-06921 Sophia Antipolis Cedex - FRANCE

Tel.: +33 4 92 94 42 00 Fax: +33 4 93 65 47 16

Siret N° 348 623 562 00017 - APE 7112B
Association à but non lucratif enregistrée à la
Sous-Préfecture de Grasse (06) N° w061004871

Important notice

The present document can be downloaded from the
[ETSI Search & Browse Standards](#) application.

The present document may be made available in electronic versions and/or in print. The content of any electronic and/or print versions of the present document shall not be modified without the prior written authorization of ETSI. In case of any existing or perceived difference in contents between such versions and/or in print, the prevailing version of an ETSI deliverable is the one made publicly available in PDF format on [ETSI deliver](#) repository.

Users should be aware that the present document may be revised or have its status changed, this information is available in the [Milestones listing](#).

If you find errors in the present document, please send your comments to the relevant service listed under [Committee Support Staff](#).

If you find a security vulnerability in the present document, please report it through our [Coordinated Vulnerability Disclosure \(CVD\)](#) program.

Notice of disclaimer & limitation of liability

The information provided in the present deliverable is directed solely to professionals who have the appropriate degree of experience to understand and interpret its content in accordance with generally accepted engineering or other professional standard and applicable regulations.

No recommendation as to products and services or vendors is made or should be implied.

No representation or warranty is made that this deliverable is technically accurate or sufficient or conforms to any law and/or governmental rule and/or regulation and further, no representation or warranty is made of merchantability or fitness for any particular purpose or against infringement of intellectual property rights.

In no event shall ETSI be held liable for loss of profits or any other incidental or consequential damages.

Any software contained in this deliverable is provided "AS IS" with no warranties, express or implied, including but not limited to, the warranties of merchantability, fitness for a particular purpose and non-infringement of intellectual property rights and ETSI shall not be held liable in any event for any damages whatsoever (including, without limitation, damages for loss of profits, business interruption, loss of information, or any other pecuniary loss) arising out of or related to the use of or inability to use the software.

Copyright Notification

No part may be reproduced or utilized in any form or by any means, electronic or mechanical, including photocopying and microfilm except as authorized by written permission of ETSI.

The content of the PDF version shall not be modified without the written authorization of ETSI.

The copyright and the foregoing restriction extend to reproduction in all media.

© ETSI 2026.
All rights reserved.

Intellectual Property Rights

Essential patents

IPRs essential or potentially essential to normative deliverables may have been declared to ETSI. The declarations pertaining to these essential IPRs, if any, are publicly available for **ETSI members and non-members**, and can be found in ETSI SR 000 314: "*Intellectual Property Rights (IPRs); Essential, or potentially Essential, IPRs notified to ETSI in respect of ETSI standards*", which is available from the ETSI Secretariat. Latest updates are available on the [ETSI IPR online database](#).

Pursuant to the ETSI Directives including the ETSI IPR Policy, no investigation regarding the essentiality of IPRs, including IPR searches, has been carried out by ETSI. No guarantee can be given as to the existence of other IPRs not referenced in ETSI SR 000 314 (or the updates on the ETSI Web server) which are, or may be, or may become, essential to the present document.

Trademarks

The present document may include trademarks and/or tradenames which are asserted and/or registered by their owners. ETSI claims no ownership of these except for any which are indicated as being the property of ETSI, and conveys no right to use or reproduce any trademark and/or tradename. Mention of those trademarks in the present document does not constitute an endorsement by ETSI of products, services or organizations associated with those trademarks.

DECT™, **PLUGTESTS™**, **UMTS™** and the ETSI logo are trademarks of ETSI registered for the benefit of its Members. **3GPP™**, **LTE™** and **5G™** logo are trademarks of ETSI registered for the benefit of its Members and of the 3GPP Organizational Partners. **oneM2M™** logo is a trademark of ETSI registered for the benefit of its Members and of the oneM2M Partners. **GSM®** and the GSM logo are trademarks registered and owned by the GSM Association.

Legal Notice

This Technical Specification (TS) has been produced by ETSI 3rd Generation Partnership Project (3GPP).

The present document may refer to technical specifications or reports using their 3GPP identities. These shall be interpreted as being references to the corresponding ETSI deliverables.

The cross reference between 3GPP and ETSI identities can be found at [3GPP to ETSI numbering cross-referencing](#).

Modal verbs terminology

In the present document "**shall**", "**shall not**", "**should**", "**should not**", "**may**", "**need not**", "**will**", "**will not**", "**can**" and "**cannot**" are to be interpreted as described in clause 3.2 of the [ETSI Drafting Rules](#) (Verbal forms for the expression of provisions).

"**must**" and "**must not**" are **NOT** allowed in ETSI deliverables except when used in direct citation.

Contents

Intellectual Property Rights	2
Legal Notice	2
Modal verbs terminology.....	2
Foreword.....	6
Introduction	7
1 Scope	8
2 References	8
3 Definitions of terms, symbols and abbreviations	8
3.1 Terms.....	8
3.2 Symbols.....	9
3.3 Abbreviations	9
4 Concepts and overview	9
4.1 Introduction and Overview.....	9
4.1.1 Digital Twins and Network Digital Twins.....	9
4.1.2 Utilizing emulation and/or simulation	10
4.2 NDT Management Service	10
4.3 Relations of NDTs and network automation functions	10
4.4 NDT Life-cycle management.....	11
5 NDT Management capabilities.....	12
5.1 Control and life cycle management of NDTs.....	12
5.1.1 Description.....	12
5.1.2 Use cases.....	12
5.1.2.1 Life cycle management of NDT instances	12
5.1.2.2 Control of NDT instances	12
5.1.2.3 Synchronization with network	12
5.1.3 Requirements	13
5.2 NDT support for network automation	13
5.2.1 Description.....	13
5.2.2 Use cases.....	13
5.2.2.1 General capabilities on NDT support for network automation	13
5.2.2.2 Support for evaluation of high-risk network operations.....	14
5.2.2.3 Support for evaluation of failure events including signalling storm	14
5.2.2.4 Network issue inducement	14
5.2.3 Requirements	15
5.3 NDT support for verification.....	15
5.3.1 Description.....	15
5.3.2 Use cases.....	15
5.3.2.1 General verification.....	15
5.3.2.2 Verification of network response to events	15
5.3.2.3 Verification of network configurations	16
5.3.2.4 Verification of automation-function configurations.....	16
5.3.3 Requirements	16
5.4 NDT support for data generation.....	17
5.4.1 Description.....	17
5.4.2 Use cases.....	17
5.4.2.1 General use case on NDT support for data generation.....	17
5.4.2.2 Using NDT to generate ML training data	17
5.4.2.3 Using NDT to generate user experience data	18
5.4.3 Requirements	18
5.5 Advanced NDT capabilities	18
5.5.1 Description.....	18
5.5.2 Use Cases.....	19

5.5.2.1	Collaboration between NDTs.....	19
5.5.3	Requirements	19
6	Management service for NDT (stage 2)	19
6.1	Management operation for NDT (MnS component type A).....	19
6.2	Information model for NDT (MnS component typeB).....	20
6.2.1	Information model definition.....	20
6.2.1.1	Imported information entities and local labels	20
6.2.1.2	Class diagram.....	20
6.2.1.2.1	Relationship.....	20
6.2.1.2.2	Inheritance	21
6.2.1.3	Class definition	21
6.2.1.3.1	NDTFunction <<InformationObjectClass>>	21
6.2.1.3.1.1	Definition	21
6.2.1.3.1.2	Attributes	21
6.2.1.3.1.3	Attribute constraints.....	21
6.2.1.3.1.4	Notifications.....	21
6.2.1.3.2	NDTJob <<InformationObjectClass>>	22
6.2.1.3.2.1	Definition	22
6.2.1.3.2.2	Attributes	22
6.2.1.3.2.3	Attribute constraints.....	22
6.2.1.3.2.4	Notifications.....	22
6.2.1.3.3	NDTFunctionScope << dataType >>	23
6.2.1.3.3.1	Definition	23
6.2.1.3.3.2	Attributes	23
6.2.1.3.3.3	Attribute constraints.....	23
6.2.1.3.3.4	Notifications.....	23
6.2.1.3.4	NDTInputDescription<<dataType>>	23
6.2.1.3.4.1	Definition	23
6.2.1.3.4.2	Attributes	23
6.2.1.3.4.3	Attribute constraints.....	23
6.2.1.3.4.4	Notifications.....	23
6.2.1.3.5	NDTOutputDescription <<dataType>>	24
6.2.1.3.5.1	Definition	24
6.2.1.3.5.2	Attributes	24
6.2.1.3.5.3	Attribute constraints.....	24
6.2.1.3.5.4	Notifications.....	24
6.2.1.3.6	ScopeDefinition <<choice>>.....	24
6.2.1.3.6.1	Definition	24
6.2.1.3.6.2	Attributes	24
6.2.1.3.6.3	Attribute constraints.....	25
6.2.1.3.6.4	Notifications.....	25
6.2.1.3.7	NdtJobExecutionReqts <<dataType>>.....	25
6.2.1.3.7.1	Definition	25
6.2.1.3.7.2	Attributes	25
6.2.1.3.7.3	Attribute constraints.....	25
6.2.1.3.7.4	Notifications.....	25
6.2.1.3.8	NDTReport <<InformationObjectClass>>	25
6.2.1.3.8.1	Definition	25
6.2.1.3.8.2	Attributes	25
6.2.1.3.8.3	Attribute constraints.....	26
6.2.1.3.8.4	Notifications.....	26
6.2.1.3.9	NDTOutputDataPoint <<dataType>>	26
6.2.1.3.9.1	Definition	26
6.2.1.3.9.2	Attributes	26
6.2.1.3.9.3	Attribute constraints.....	26
6.2.1.3.9.4	Notifications.....	26
6.2.1.3.10	SimulationDataDescriptor <<dataType>>	26
6.2.1.3.10.1	Definition	26
6.2.1.3.10.2	Attributes	26
6.2.1.3.10.3	Attribute constraints.....	27
6.2.1.3.10.4	Notifications.....	27

6.2.1.3.11	SimulationData <<dataType>>	27
6.2.1.3.11.1	Definition	27
6.2.1.3.11.2	Attributes	27
6.2.1.3.11.3	Attribute constraints	27
6.2.1.3.11.4	Notifications	27
6.2.1.3.12	PerformanceData <<dataType>>	27
6.2.1.3.12.1	Definition	27
6.2.1.3.12.2	Attributes	28
6.2.1.3.12.3	Attribute constraints	28
6.2.1.3.12.4	Notifications	28
6.3	Attribute definitions	29
6.3.1	Attribute properties	29
6.4	Procedure for NDT management	34
6.4.1	Procedure for consuming NDT management service	34
6.4.2	Procedure for delete an NDT job	35
6.4.3	Procedure for query an NDT job	35
6.5	Common notifications	36
6.5.1	Configuration notifications	36
7	Management service for NDT (stage 3)	36
7.1	RESTful HTTP-based solution set	36
Annex A (informative): PlantUML source code		38
A.1	Information model definition for NDT	38
A.1.1	Relationship UML diagram for NDT management	38
A.1.2	Inheritance UML diagram for NDT management	38
A.2	Procedure for NDT management	38
A.2.1	Procedure for delete an NDT job	38
A.2.2	Procedure for query an NDT job	39
Annex B (informative): NDT function in different domains		40
B.1	NDT function in RAN domain	40
B.2	NDT function in cross domain	40
Annex C (informative): Change history		41
History	44

Foreword

This Technical Specification has been produced by the 3rd Generation Partnership Project (3GPP).

The contents of the present document are subject to continuing work within the TSG and may change following formal TSG approval. Should the TSG modify the contents of the present document, it will be re-released by the TSG with an identifying change of release date and an increase in version number as follows:

Version x.y.z

where:

- x the first digit:
 - 1 presented to TSG for information;
 - 2 presented to TSG for approval;
 - 3 or greater indicates TSG approved document under change control.
- y the second digit is incremented for all changes of substance, i.e. technical enhancements, corrections, updates, etc.
- z the third digit is incremented when editorial only changes have been incorporated in the document.

In the present document, modal verbs have the following meanings:

- shall** indicates a mandatory requirement to do something
- shall not** indicates an interdiction (prohibition) to do something

The constructions "shall" and "shall not" are confined to the context of normative provisions, and do not appear in Technical Reports.

The constructions "must" and "must not" are not used as substitutes for "shall" and "shall not". Their use is avoided insofar as possible, and they are not used in a normative context except in a direct citation from an external, referenced, non-3GPP document, or so as to maintain continuity of style when extending or modifying the provisions of such a referenced document.

- should** indicates a recommendation to do something
- should not** indicates a recommendation not to do something
- may** indicates permission to do something
- need not** indicates permission not to do something

The construction "may not" is ambiguous and is not used in normative elements. The unambiguous constructions "might not" or "shall not" are used instead, depending upon the meaning intended.

- can** indicates that something is possible
- cannot** indicates that something is impossible

The constructions "can" and "cannot" are not substitutes for "may" and "need not".

- will** indicates that something is certain or expected to happen as a result of action taken by an agency the behaviour of which is outside the scope of the present document
- will not** indicates that something is certain or expected not to happen as a result of action taken by an agency the behaviour of which is outside the scope of the present document
- might** indicates a likelihood that something will happen as a result of action taken by some agency the behaviour of which is outside the scope of the present document

might not indicates a likelihood that something will not happen as a result of action taken by some agency the behaviour of which is outside the scope of the present document

In addition:

is (or any other verb in the indicative mood) indicates a statement of fact

is not (or any other negative verb in the indicative mood) indicates a statement of fact

The constructions "is" and "is not" do not indicate requirements.

Introduction

1 Scope

The present document specifies the terms and concepts of Network Digital Twin, as well as the use cases, requirements, and solutions for Network Digital Twins within the 3GPP management system.

The present document applies to the service based management architecture.

2 References

The following documents contain provisions which, through reference in this text, constitute provisions of the present document.

- References are either specific (identified by date of publication, edition number, version number, etc.) or non-specific.
- For a specific reference, subsequent revisions do not apply.
- For a non-specific reference, the latest version applies. In the case of a reference to a 3GPP document (including a GSM document), a non-specific reference implicitly refers to the latest version of that document *in the same Release as the present document*.

- [1] 3GPP TR 21.905: "Vocabulary for 3GPP Specifications".
- [2] 3GPP TS 28.552: "Management and orchestration; 5G performance measurements".
- [3] 3GPP TS 28.554: "Management and orchestration; 5G end to end Key Performance Indicators (KPI)".
- [4] 3GPP TS 32.422: "Telecommunication management; Subscriber and equipment trace; Trace control and configuration management".
- [5] 3GPP TS 28.111: "Management and orchestration; Fault Management (FM)".
- [6] 3GPP TS 28.541: "Management and orchestration; 5G Network Resource Model (NRM); Stage 2 and stage 3".
- [7] 3GPP TS 28.622: "Telecommunication management; Generic Network Resource Model (NRM) Integration Reference Point (IRP); Information Service (IS)".
- [8] 3GPP TS 28.532: "Management and orchestration; Generic management services".
- [9] 3GPP TS 28.104: "Management and orchestration; Management Data Analytics (MDA)".

3 Definitions of terms, symbols and abbreviations

3.1 Terms

For the purposes of the present document, the terms given in TR 21.905 [1] and the following apply. A term defined in the present document takes precedence over the definition of the same term, if any, in TR 21.905 [1].

Network Digital Twin (NDT): virtual replica of mobile network or part of one, that captures its attributes, behaviour and interactions

NOTE 1: Mobile network includes both RAN and Core Network.

NOTE 2: An NDT can collaborate with other NDTs during simulation or emulation activities, and dynamically adapt its internal behaviour accordingly.

3.2 Symbols

For the purposes of the present document, the following symbols apply:

<symbol> <Explanation>

3.3 Abbreviations

For the purposes of the present document, the abbreviations given in TR 21.905 [1] and the following apply. An abbreviation defined in the present document takes precedence over the definition of the same abbreviation, if any, in TR 21.905 [1].

AMF	Access and Mobility Management Function
CSPs	Communication Service Providers
DT	Digital Twin
ES	Energy Saving
MDA	Management Data Analytics
MDAF	Management Data Analytics Function
ML	Machine Learning
MOI	Managed Object Instance
NDT	Network Digital Twin
NDT MnS	Network Digital Twin Management service
SMF	Session Management FunctionS-NSSAI Single Network Slice Selection Assistance Information
SON	Self-Organizing Networks
UDM	Unified Data Management
UL/DL	Uplink / Downlink

4 Concepts and overview

4.1 Introduction and Overview

4.1.1 Digital Twins and Network Digital Twins

A **digital twin** is a software representation of an object or a set of objects for the purpose of modelling some of the characteristics and behaviours of such real-world object(s) or system(s). The digital twin provides support to network management and operations by creating a virtual representation of the corresponding physical network process(es). A digital twin can be created for any physical object, including any objects in communication networks. The digital twin may also be created for a group of objects, e.g. for the sets of network objects that form the RAN segment or the NFs in the Core network.

Accordingly, a digital twin modelling an object, or a set of objects, of a communication network is called **Network Digital Twin**.

Network Digital Twin (NDT) is used as a replica of a mobile network, to learn how an actual mobile network would behave in certain scenarios, without causing any changes to the actual mobile network. To provide meaningful results, an NDT needs to model the behaviour of the mobile network, so that the result of the operations on the virtual replica is a good approximation to the result of similar operations on the actual network. The created NDT can provide the capability of reporting the topology of the network, and the non-topology aspects of the real network which includes both network elements (e.g., 5GC NFs or gNB) information and infrastructure resource information. The implementation of an NDT can rely on simulation, emulation, AI-based modelling, or any other technique that enables the NDT to mimic the behaviour of the network. The present document uses the term “simulation/emulation” to refer to any combination of the techniques previously listed.

Thus, the NDT can contribute to efficient management of mobile networks, help to build resilient networks, enable the early deployment of new services, and enhance network quality. For example, with NDT, network operators can verify

network behaviour before they apply configuration changes to the real network to prevent unintended behaviour, which contributes to resilient networks and enhancement of network quality. Additionally, network automation function can use NDT to analyze network behaviour, which can contribute to reducing operator's manual operation and improve management efficiency. NDT may also utilize network automation functions to prepare and deliver NDT reports.

4.1.2 Utilizing emulation and/or simulation

The implementation of NDT modelling relies on simulation, emulation or other modelling technologies that enables the NDT to mimic the behaviour of the network.

Simulation implies that the NDT uses a mathematical model to represent the behaviour of the system. This is used e.g. to model the traffic generated by users in the RAN to model the movement of users, or to model simplified behaviour of a NF. Emulation on the other hand implies that the NDT uses a realizable component - such as software implementation - that replicates the behaviour of one or more real system components. This is used e.g. to replicate or mimic the functionalities of core network functions which are implemented using the real software of NFs.

It is possible to combine emulation and simulation to create an integrated solution. The choice depends on implementation and deployment considerations, and is thus out of scope of this specification.

4.2 NDT Management Service

NDT MnS Producer enables an authorized consumer to request the modelling of a network scenario and to receive the output report. The simulation/emulation capabilities provided by the NDT MnS Producer can be invoked by management functions, e.g., MDAF, AIML Inference Function, Intent Handling Function, when playing the role of an NDT MnS Consumer, to support their intelligence and automation functionality.

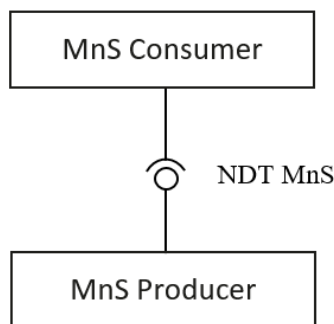
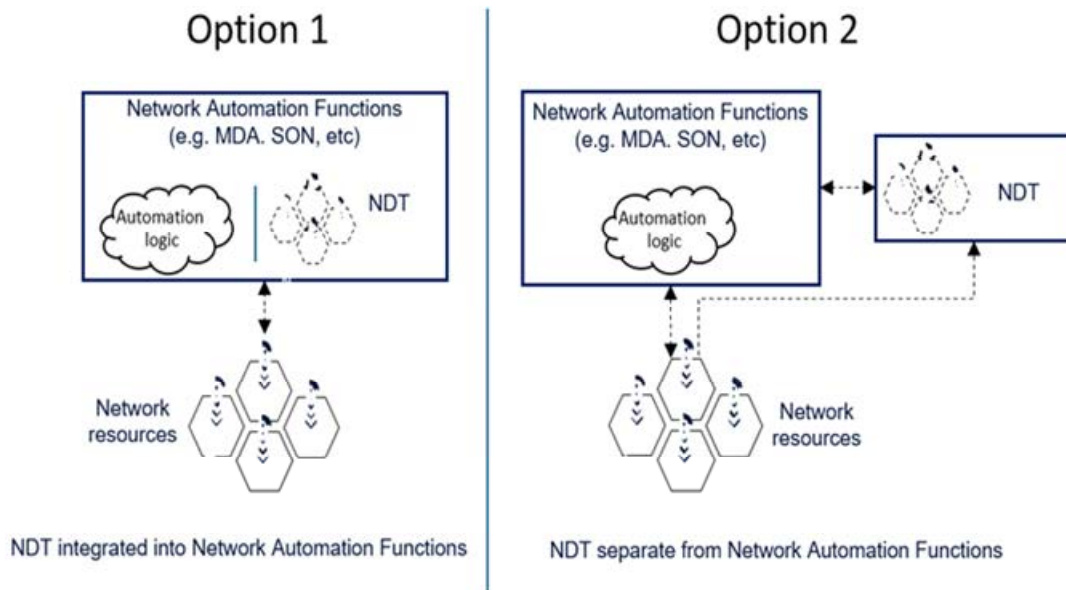

Figure 4.2-1: MnS Producer and MnS consumer of the NDT MnS

4.3 Relations of NDTs and network automation functions

Existing automation capabilities include analytics services and decision-making capabilities with the assumption that the knowledge about network behaviour is available within the automation functions. Accordingly, the unaddressed gap for network automation is related to the capabilities for modelling the behaviour of the network. The Network Resource Model (NRM) is used to describes the attributes of a mobile network and their relationships. The Network Digital Twin facilitates modelling the behaviour of a mobile network or parts of it, and the analytic data from automation functions (e.g., MDA) may also be utilized when needed, by the NDT. Network digital twins could also provide modelling capabilities that support network automation functions (e.g. MDA, SON, etc.) to accomplish their automation objectives. When the network digital twin provides modelling capabilities for the network, it can be integrated inside or outside of existing network automation functions. - see figure 4.3-1, and the different options considered are implementation-specific.



- Option 1 NDT internal/integrated into existing Network Automation Functions.
 Option 2 NDT separate from existing Network Automation Functions

Figure 4.3-1: Relation of NDTs with network automation functions

NOTE: The double headed arrows indicate candidate flow of data or control while one headed arrow indicates only flow of data.

4.4 NDT Life-cycle management

An NDT function instance is a manageable object that provides simulation and emulation capabilities for specific network scenarios. An NDT may have multiple simulation/emulation jobs (here called NDT jobs) each considering a different network scenario and use case.

Accordingly,, the LCM includes two aspects: the LCM of the NDT function instance and the LCM of the NDT job instances. The following capabilities are included:

- NDT function creation: The MnS producer who provides the NDT simulation/emulation capabilities creates an NDT function instance that is capable of modelling a specific scenario.
- NDT job instantiation: NDT MnS producer receives the request to create a job. The NDT MnS producer instantiates and executes the simulation/emulation for this job, which is an NDT job instance. The NDT job instance can be configured by the MnS consumer at any time.
- NDT job suspension: NDT MnS producer receives the request to pause or suspend a job.
- NDT job deletion: NDT MnS producer receives the request to delete a simulation/emulation job instance. The NDT MnS producer stops the execution of the simulation/emulation and deletes the NDT job instance.
- NDT function deletion: the MnS producer may delete an NDT function instance that is not active.

NOTE: All the life cycle operations may not be valid for all NDT Function instances. For example, a particular NDT function instance may not support suspending the NDT job execution.

5 NDT Management capabilities

5.1 Control and life cycle management of NDTs

5.1.1 Description

This describes uses on control and life cycle management of NDT instances.

5.1.2 Use cases

5.1.2.1 Life cycle management of NDT instances

NDTs can be used for many application use cases. In each case, the NDT needs to implement a defined network scenario, run a simulation/emulation of that scenario, and subsequently provide an output representing the statuses of different network for the simulated network scenario. The lifecycle management of NDT refers to the management processes that control and transition an NDT instance through the processes of creation, activation, operation, deactivation, deletion and any updates during these processes. At each step, it is critical to ensure that the NDT instance accurately reflects the status of physical entities and support efficient simulation/emulation.

- For creation, the NDT MnS Consumer may provide requirements to request the NDT MnS producer to trigger the creation of an NDT job instance based on its capabilities. NDT MnS producer may create a new NDT job instance from scratch, updating existing NDT models or to combining existing NDT models to generate a new NDT.
- At any point during the life of an NDT job instance, the MnS consumer may provide physical network data to refine and adjust the NDT job instances to accurately reflect the status of the physical entity and adapt it to specific application scenarios. For example, the consumer may trigger data collection from the network and synchronization of the state with the NDT job.

5.1.2.2 Control of NDT instances

The 3GPP management system should support capabilities enabling consumers to define the network scenario, to control (start, suspend, resume or stop) the simulation/emulation of that network scenario and to provide outcomes representing measurements and counters from metrics in the simulated/emulated network scenario.

An NDT job may have dependencies on other NDTs jobs or DTs external to the 3GPP management system, each of which implements a specific network scope. The MnS consumer should also be enabled to provide input to NDT job MnS Producer to create relationship among NDT job instances, i.e., configure or modify the dependencies (e.g., to select which environment or radio propagation model to be applied).

5.1.2.3 Synchronization with network

The NDT function need to obtain information from physical network including network functions and entities. The collected information includes the following:

- Performance data: Performance measurement or the KPI as defined in 3GPP TS 28.552 [2] and 3GPP TS 28.554 [3].
- MDT/Trace data: MDT measurements as defined in 3GPP TS 32.422 [4].
- Fault management data: Fault management data as defined in 3GPP TS 28.111[5]
- Configuration data: Configuration data defined in 3GPP TS 28.541 [6] and 3GPP TS 28.622 [7], any of the available MOIs;

Mobile networks are generally composed of numerous network elements. The data about these numerous network elements can potentially be vast. When collecting this vast amount of data to be used by NDT jobs, the collection might cause congestion in the network used for data collection. NDT MnS Producer may create an NDT job instance according to data provided by the NDT MnS Consumer or collect the data from the physical network for

synchronization. The MnS producer should enable the MnS consumer to control the frequency of data to be collected by the NDT to minimize unnecessary collection of data and minimal congestion.

5.1.3 Requirements

Table 5.1.3-1: Control and life cycle management of NDTs

Requirement label	Description	Related use case(s)
REQ-DTLCM-01:	The 3GPP management system should support a capability enabling an authorized MnS consumer to define the network scenario that should be modelled and simulated/emulated.	Life cycle management of NDT instances (See clause 5.1.2.1)
REQ-DTLCM-02:	The 3GPP management system should support a capability enabling an authorized MnS consumer to control the simulation/emulation of a network scenario, e.g. to start, or stop the simulation/emulation.	Life cycle management of NDT instances (See clause 5.1.2.1)
REQ-DTLCM-03:	The 3GPP management system should support a capability to provide to an authorized MnS consumer an output of a modelling or simulation process, the output representing the status of the network for the simulated scenario.	Life cycle management of NDT instances (See clause 5.1.2.1)
REQ-DTLCM-04:	The 3GPP management system should support a capability to allow the MnS consumer to provide input to NDT MnS Producer to create relationship among NDT instances	Control of NDT instances (See clause 5.1.2.2)
REQ-DTLCM-05:	The 3GPP management system should have the capability enabling an authorized MnS consumer to control the frequency of network data collection.	Synchronization with network (See clause 5.1.2.3)

5.2 NDT support for network automation

5.2.1 Description

NDTs can be used to support automation use cases (e.g. MDA, SON, etc.). An NDT may be integrated into a network automation function, or it may be external to the network automation function. In the case where the NDT is external to the network automation function, it could be possible for the network automation function to configure the NDT jobs and the scenario that could be modelled by the NDT. NDTs do not execute any actions in form of configuration of the live network but support decision-making.

5.2.2 Use cases

5.2.2.1 General capabilities on NDT support for network automation

An NDT, depending upon the network or service management use case and scenario to be modelled, might need data originating from various sources internal or external to the 3GPP management system (network data, environment data, analytic, UEs data) and suitable hardware/software resources to function properly. MnS consumers would need to specify needed NDT characteristics or configurations to the NDT tailored to fulfil consumer specific needs i.e., to define the consumer preference for the specific NDT. For example, consumer preferences may be related to environment data sources e.g., weather, synthetic data etc, data characteristics (e.g., robustness, data granularity, maximum tolerable latency), required NDT job output (e.g., latency), characteristics of the service to be twinned, resource constraints (HW/SW), etc. Furthermore, in the case that consumer's preference on NDT characteristics or configuration may change over time and MnS consumer may update the NDT job with the needed changes.

The achieved performance by NDT job, may depend on NDT characteristics such as load, time or energy saving state. This means that the simulation results would change based on the network load, the target time of the day, or on whether the simulated node is running in energy saving mode. The NDT report should indicate the performance for the respective configured NDT characteristics. The network performance, such as latency, throughput, etc., contained in the NDT report can be used by the NDT MnS Consumer to evaluate the network performance of the modelled scenario.

The automation scenarios that the NDT might support are described in following sub-clauses.

5.2.2.2 Support for evaluation of high-risk network operations

Each operation for network optimization and maintenance on a mobile network may cause potential network failures, including network congestion leading to lack of ability to fulfil the expected requirements and network breakdown. High-risk operations are operations which have the potential of causing major service impact, for instance, invalid configuration or policy modification. Other network activities such as software version upgrade, board switching, or optimization procedures on a live network may cause major network degradation and may be considered as high-risk operations. NDT can be utilized to evaluate both known high-risk network operations and those optimization and verification of network policies suspected to pose high-risk consequences to the network.

The results of NDT jobs execution can be used to provide improved system awareness and insights to the consumer and can aid in finding the optimal policy or solution and in avoiding or minimizing risks.

5.2.2.3 Support for evaluation of failure events including signalling storm

The NDT can be used to support the evaluation of failure event refers to the situation where users in the network are completely unable to get service from the network. A typical example of a failure event is signalling storm, where a large number of signalling messages suddenly surge in the mobile communication network, overloading the network's processing capacity and consequently degrading the network performance and stability. During this period, users will repeatedly try to establish the connection until reconnected, thus generating a large number of signalling messages surge suddenly, causing signalling storm. When a signalling storm occurs on the network, network Functions (NFs) such as AMF, SMF, and UDM in the 5G network might all be potential impact points. Therefore, when received the request with network object information from MnS consumer for signalling storm analysis, the NDT can execute the modelling and validation based on network object related information (network performance, KPIs, S-NSSAIs, etc.), which synchronized from the network resources, and provide the report with the modelling results to MnS consumer.

An automation function may propose a solution to a signalling storm. The NDT can be used to evaluate the appropriateness of the proposed solution (e.g., update the configuration of network flow control parameters) based on the analysing of failure events for resolving, predicting and preventing the signalling storm issue.

NDT models network behaviors and provides information on potential impacts of network failures, including surges in signalling requests. For instance, in case of the signalling storm, the information can enable identification of optimal flow control parameters for each signalling impact point.

5.2.2.4 Network issue inducement

This use case describes how a network issue can be induced using NDT. A resilient network requires that the behaviour and performance of the network are monitored during certain network failure event e.g. node/functionality failure, service degradation etc. To plan for the optimal network configuration in case of such network failure event, NDT can be used for issue inducements. For a particular issue that is induced, the NDT measures performance identifies degradation/faults/failures and the mitigation actions can be decided with the assistance of an automation function. The following are some of the examples of the issues that can be induced.

Scenario 1: Service degradation - The network slice performance degradation in terms of low PDU session establishment success rate or in terms of high latency can be induced, in a NDT, to see how the related network functions will behave when the PDU session establishment success rate is degraded. The remedial actions can be decided to mitigate the problem.

Scenario 2: Coverage issue - The coverage issue can be induced, in a NDT, to see how the related services are getting effected. The remedial actions can be decided to mitigate the problems arising due to the induced coverage issue.

Scenario 3: Fault injection - NDT can be used for fault injection experiments avoiding impact on the physical network while measuring and monitoring the impact of each injected fault in the NDT simulation. This could be leveraged to build a training data set for enhancing and enriching detection and diagnosing systems capabilities. In addition, NDT could be leveraged for improving root causes analysis.

5.2.3 Requirements

Table 5.2.3-1: NDT support for network automation

Requirement label	Description	Related use case(s)
REQ-NDTAUTO-01:	The 3GPP management system should support a capability enabling an authorized MnS consumer to specify characteristics or configurations of the network scenario to be modelled in the NDT job.	General capabilities on NDT support for network automation (Clause 5.2.2.1)
REQ-NDTAUTO-02:	The 3GPP management system should support a capability to report to the authorized MnS consumer the simulation/ emulation output by NDT job.	General capabilities on NDT support for network automation (Clause 5.2.2.1)
REQ-NDTAUTO-03:	The 3GPP management system should support a capability enabling an authorized MnS consumer to define and request simulation/ emulation of a network optimization operations.	Support for evaluation of high-risk network operations (Clause 5.2.2.2)
REQ-NDTAUTO-04:	The 3GPP management system should have a capability enabling an authorized MnS consumer to configure the network scenario to be modelled for the consumer to evaluate a network failure.	Support for evaluation of high-risk network operations (Clause 5.2.2.2)
REQ-NDTAUTO-05:	The 3GPP management system should support a capability to model the behaviour of the signalling storm in network.	Support for evaluation of failure events including Signaling storm (Clause 5.2.2.3)
REQ-NDTAUTO-06:	The 3GPP management system should support a capability enabling an authorized MnS consumer to define and request simulation/ emulation of the proposed solution for resolving a set of network failure events, including signalling storm.	Support for evaluation of failure events including Signaling storm (Clause 5.2.2.3)
REQ-NDTAUTO-07:	The 3GPP management system should support a capability enabling an authorized MnS consumer to request inducement of a network issue by an NDT job.	Network issue inducement (Clause 5.2.2.4)
REQ-NDTAUTO-08:	The 3GPP management system should have a capability for NDT MnS producer to report the impact of the injected issue in NDT.	Network issue inducement (Clause 5.2.2.4)

5.3 NDT support for verification

5.3.1 Description

This describes NDT use in support of verification.

5.3.2 Use cases

5.3.2.1 General verification

To evaluate a network scenario, the NDT needs to be configured with data defining a network scenario, and where applicable, the configurations and functionalities to be evaluated. The MnS consumer should be enabled to configure the NDT job accordingly. Given the scenario, configurations and functionalities, the consumer can then control the simulation (e.g. to start or stop the simulation) according to the LCM capabilities as described in clause 5.1. The NDT simulates the defined scenario configurations and functionalities and collects data, which is then compiled into an NDT report. The MnS consumer should be enabled to configure the information that should be included in the simulation report. The NDT MnS producer should be enabled to send the simulation report to MnS consumer to indicate the network simulation results.

5.3.2.2 Verification of network response to events

The network can experience different kinds of events, including failure and non-failure events. A failure event refers to the situation where the network does not behave as expected, e.g., where users in the network are completely unable to get service from the network. A non-failure event refers to the situation where the network experiences an unusual

occurrence, but users are still able to get service. The NDT can be used to evaluate how the network responds to any of these events. The NDT can model network behaviors and provide information on potential impact of network events. The NDT can be used to evaluate if a particular event will cause a network failure or whether the network can withstand the event.

The following is an example of events that can be supported:

- Signalling storms: A signalling storm is a failure event where a large number of signalling messages suddenly surge in the mobile communication network, resulting in the network processing capacity overload, thus affecting the network performance and stability. During this period, users will repeatedly try to establish the connection until reconnected, thus generating many signalling messages surge suddenly, causing a signalling storm. In this scenario, NDT is used to simulate/emulate the network behaviour of surges in signalling requests on the network. For example, NDT can simulate/emulate a sudden surge in the number of UE requests in the scenario of major holidays or network interruption recovery. Operators can also select the multiplication factor for the surge in signalling requests to be injected in NDT to evaluate the network resilience capability in response to different severity levels of events.

5.3.2.3 Verification of network configurations

Several configurations can be provided to the network, either as modifications to single parameters or as bulk configurations, e.g., as a configuration plan. There may be multiple configurations that are iteratively executed in NDT until the network performance, e.g. energy efficiency of NG-RAN, UE throughput in gNB, etc., meets the operators' requirements. The MnS consumer should be enabled to configure the NDT job with data defining a network scenario to be evaluated as well as the input information that should be applied to network in that scenario. The information may include configurations, simulated network scenarios or simulated traffic patterns.

The configurations can be evaluated for any network scenarios including the event listed in 5.3.2.1

5.3.2.4 Verification of automation-function configurations

Besides network configurations, network automation functionality (e.g., SON functions) may also be configured., e.g. configurations of functionality say for energy savings. The NDT can be used to evaluate the configurations of the automation functionality. The MnS consumer should be enabled to configure the NDT with data defining a network scenario to be evaluated for one or more automation functionality with the corresponding input information that should be applied to automation functionality to be evaluated. The information may include configurations, simulated network scenarios or simulated traffic patterns.

An example scenario of automation configuration verification is verification of Configuration of RAN energy saving management function (RAN ES MnF). A RAN ES MnF derives and executes network management operations via provisioning MnS to maximize energy saving for a group of cells e.g. based on the degree to which the cells overlap with each other. The NDT can be used to evaluate the configurations of the RAN ES MnF, i.e., the MnS consumer may instantiate an NDT simulation/emulation to verify the RAN ES configuration. The verification can be for configuration of behavior including which cells are grouped for ES and their degree of overlap. The verification can also be for configuration of performance requirements, which is MnS consumer's requirements for network simulation performance, e.g., energy efficiency, RAN UE throughput, precision, maximum run time, etc. NDT performs network simulation/emulation, i.e., simulating/emulating the execution of RAN ES according to the configured behavior and performance requirements and collects its impact on the simulated network.

5.3.3 Requirements

Table 5.3.3-1: NDT support for verification

Requirement label	Description	Related use case(s)
REQ-NDTVER-01:	The management system should support a capability enabling an authorized MnS consumer to define the information that should be included in the report/output on the simulation/emulation of verification of network scenarios and configurations.	General verification (Clause 5.3.2.1)
REQ-NDTVER-02:	The management system should have a capability enabling an authorized MnS consumer to define one or more network events to be modelled and evaluated by the NDT job.	Verification of network response to events (Clause 5.3.2.2)

Requirement label	Description	Related use case(s)
REQ-NDTVER-03:	The management system should have the capability to report the simulation/emulation outcomes on the verification of one or more network events to be modelled and evaluated by the NDT job.	Verification of network response to events (Clause 5.3.2.2)
REQ-NDTVER-04:	The management system should have a capability enabling an authorized MnS consumer to define one or more network configurations to be modelled and evaluated by the NDT job.	Verification of network configurations (Clause 5.3.2.3)
REQ-NDTVER-05:	The management system should have the capability to report the simulation/emulation outcomes on the verification of network configurations modelled and evaluated by the NDT job.	Verification of network configurations (Clause 5.3.2.3)
REQ-NDTVER-06:	The management system should have a capability enabling an authorized MnS consumer to define one or more automation functionality and configurations for the automation functionality to be modelled and evaluated by the NDT job.	Verification of automation-function configurations (Clause 5.3.2.4)
REQ-NDTVER-07:	The management system should have the capability to report the outcomes on the verification of one or more automation functionality and configurations modelled and evaluated by the NDT job.	Verification of automation-function configurations (Clause 5.3.2.4)

5.4 NDT support for data generation

5.4.1 Description

NDTs can be used to support the generation of data in different application use cases.

5.4.2 Use cases

5.4.2.1 General use case on NDT support for data generation

NDT can be utilized to send a report to the MnS consumer with generated data and information related to network scenarios, configurations, policies, and performance outcomes. When receiving the request from the MnS consumer, the MnS Producer creates the NDT job and determines the simulated objects and data (e.g., PM data, CM data) according to data requirements. The simulated objects include simulated network areas and managed objects in NDT. And then, according to the simulated objects and data, the MnS Producer collects the data from the physical network used for NDT job simulation. Subsequently, based on the collected data, the MnS Producer creates/activates NDT instance, executes the network simulation and generates data corresponding to the request by using the NDT.

The data generation scenarios that the NDT might support include those in following sub-clauses.

5.4.2.2 Using NDT to generate ML training data

ML training usually requires reliable and data with a wide variety and range to guarantee the good performance of the ML models. Sufficient ML training data plays a key role for training the ML model. In general, the ML training data for network related use cases is obtained through historical network management data. For instance, for training an ML model for the MDA SLS analysis use case, described in TS 28.104 clause 7.2.2, the raw feature of training data could be the enabling data, such as UL/DL throughput, uplink/downlink delay, etc., as specified in clause 8.4.2 of TS 28.104 [9] can be used.

However, obtaining data from the network has the following limitations:

- The quantity of issues that happened in the actual mobile network is limited.
- The variety of issues that happened in actual mobile network is limited. There could be too many corner cases that rarely happen in a live network but can impact the performance of the ML model.

To overcome these challenges, the NDT MnS Consumer can request the NDT to generate data with an indication of data requirements, e.g. data type, required data period, data sampling periods, etc. When the request is sent by the NDT MnS Consumer, the NDT job can execute the simulation/emulation and as an output generate data corresponding to the request. By using an appropriate amount of training data, the NDT MnS Consumer has a better opportunity to enhance the model accuracy.

5.4.2.3 Using NDT to generate user experience data

For operators, it is important to accurately measure user satisfaction with the network services from a network usage perspective. When the performance metrics related to customer satisfaction are low, operators are eager to identify the underlying causes and determine ways to boost performance.

Multiple factors influence user satisfaction, including user service quality, network usage experience etc. NDTs can be used to model and simulate end-user behaviors within the network, providing valuable insights for improving network services by generating simulation results, e.g. KPIs/PMs related to service experience of end users. The results may be provided to other network functionalities, e.g. MDA, for further analysing the customer satisfaction level for network services.

The satisfaction with network service is affected by a combination of factors. NDT can be utilized to model network services by integrating multi-domain data sources, including network performance data, user experience data, and fault predictions, and to report the user experience data.

This proactive approach allows CSPs (in this case, the NDT MnS Consumer) to identify potential detractors who are not satisfied with services across the network, monitor the end user journey, gain deeper insights into the end user's needs, and perform refined experience management based on user groups.

5.4.3 Requirements

Table 5.4.3-1: NDT support for data generation

Requirement label	Description	Related use case(s)
REQ-NDTDG-01:	The 3GPP management system should support a capability to provide an output on the simulation/emulation enabling generation of data.	General use case on NDT support for data generation (See clause 5.4.2.1)
REQ-NDTDG-02:	The 3GPP management system should have the capability to allow an authorized MnS consumer to request generation of simulated network data to be used for ML training	Using NDT to generate ML training data (See clause 5.4.2.2)
REQ-NDTDG-03:	The 3GPP management system should support a capability to report the generated data for ML training.	Using NDT to generate ML training data (See clause 5.4.2)
REQ-NDTDG-04:	The 3GPP management system should support a capability to allow an authorized MnS consumer to request generation of the user experience related data.	Using NDT to generate user experience (See clause 5.4.3)
REQ-NDTDG-05:	The 3GPP management system should support a capability to report the generated user experience related data.	Using NDT to generate user experience (See clause 5.4.3)

5.5 Advanced NDT capabilities

5.5.1 Description

This clause describes advanced uses of Network digital twins.

5.5.2 Use Cases

5.5.2.1 Collaboration between NDTs

A single NDT Function might not be able to fulfil a task by itself and may depend on or need to use the service or outputs of another NDT Function during the simulation/emulation activity. This means that NDT Functions may have the capability to collaborate with each other, exchanging information including data that can be shared and dynamically adapting their behavior according to the exchanged information. The collaborations between multiple NDT Functions can be within the same management domain or between different management domains.

The NDT MnS Consumer may express its preferences regarding relationships between NDT Functions to jointly fulfil the scenario to be modelled. Based on the NDT MnS Consumer's input, the NDT MnS Producer may evaluate whether such collaboration is necessary and determines how it can be realized..

The benefits of collaboration between NDT Functions are:

- NDT Functions collaboration may lead to a broader system awareness and promotes flexibility
- Complex scenarios can be fulfilled jointly by collaborating NDT Functions instances.

5.5.3 Requirements

Table 5.5.3-1: Advanced NDT capabilities

Requirement label	Description	Related use case(s)
REQ- NDTAUT-01	The 3GPP management system should support a capability enabling an authorized MnS consumer to configure relation between NDTs Functions.	Collaboration between NDTs (Clause 5.5.2.1)

6 Management service for NDT (stage 2)

6.1 Management operation for NDT (MnS component type A)

The operations (e.g., createMOI operations) and notifications (e.g., notifyMOIcreation) of generic provisioning MnS defined in 3GPP TS 28.532 [8] can be used for NDT management, including NDT function management, NDT job management and NDT report management. The NDTFunction, NDTJob, NDTReport instances can be treated as Managed Object instances.

Following is the IS to support NDT lifecycle management:

Table 6.1-1: IS to support NDT function management

NDT function management	IS operation
Query an NDT function	getMOIAttributes operation

Following is the IS to support NDT job management:

Table 6.1-2: IS to support NDT job management

NDT job management	IS operation
Create an NDT job	createMOI operation
Delete an NDT job	deleteMOI operation
Modify an NDT job	modifyMOIAttributes operation
Query an NDT job	getMOIAttributes operation

Following is the IS to support NDT report management:

Table 6.1-3: IS to support NDT report management

NDT lifecycle management	IS operation
Query an NDT report	getMOIAttributes operation
Subscribe an NDT report	createMOI operation
Notify an NDT report	notifyMOIAttributeValueChanges notification
Unsubscribe an NDT report	deleteMOI operation
Query an NDT report subscription	getMOIAttributes operation

6.2 Information model for NDT (MnS component typeB)

6.2.1 Information model definition

6.2.1.1 Imported information entities and local labels

3GPP TS 28.622 [7], Top	Top
3GPP TS 28.622 [7], ManagedFunction	ManagedFunction
3GPP TS 28.622 [7], DataType, GeoArea	GeoArea
3GPP TS 28.622 [7], DataType, ThresholdInfo	ThresholdInfo
3GPP TS 28.622 [7], ConditionMonitor	ConditionMonitor

6.2.1.2 Class diagram

6.2.1.2.1 Relationship

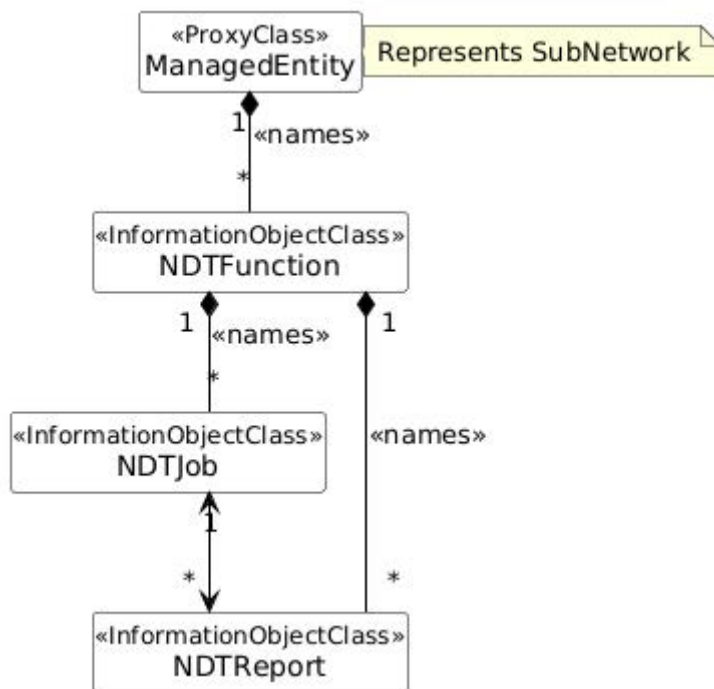

Figure 6.2.1.2.1-1: Relationship UML diagram for NDT management

6.2.1.2.2 Inheritance

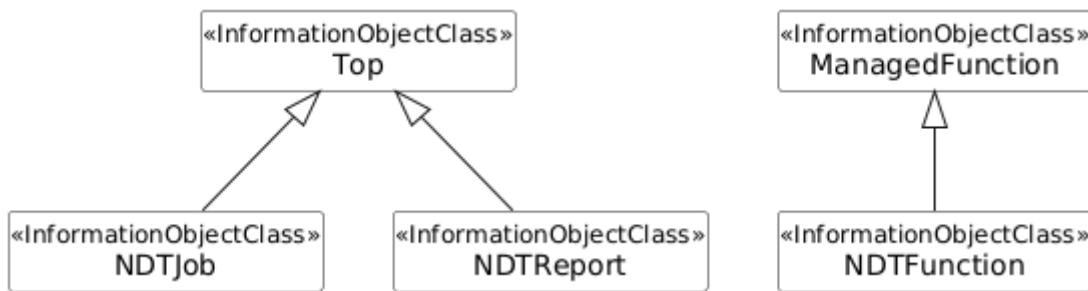

Figure 6.2.1.2.2-1: Inheritance UML diagram for NDT management

6.2.1.3 Class definition

6.2.1.3.1 NDTFunction <<InformationObjectClass>>

6.2.1.3.1.1 Definition

This IOC represents the properties of a specific NDT Function of MnS Producer. NDTFunction instances are created by the MnS producer or are pre-installed, and also are modified, deleted by the MnS producer if needed. MnS consumers cannot request to create, modify or delete NDTFunction instances.

The NDTFunction includes a reference to one or more NDTFunction instances which act as component NDTs contributing to the functionality of the NDTFunction for NDT Collaboration.

To support collaboration among NDT Functions, the NDTFunction includes “ndtFunctionRefList” attribute indicating that an NDT Function may be associated with one or more other NDT Functions. For example, one or more NDT Functions with small scope might support the operation of an NDT Function with a wider scope.

NOTE: The relationship among NDTReport of collaborating NDTFunctions is not defined.

6.2.1.3.1.2 Attributes

The NDTFunction IOC includes attributes inherited from ManagedFunction IOC (defined in 3GPP TS 28.622 [7]) and the following attributes.

Table 6.2.1.3.1.2-1

Attribute Name	Support Qualifier	isReadable	isWritable	isInvariant	isNotifyable
supportedNDTCapabilities	M	T	F	T	T
ndtFunctionScope	M	T	F	F	T
Attribute related roles					
ndtFunctionRefList	O	T	T	F	T

6.2.1.3.1.3 Attribute constraints

None.

6.2.1.3.1.4 Notifications

The common notifications defined in clauses 6.5 are valid for this IOC.

6.2.1.3.2 NDTJob <<InformationObjectClass>>

6.2.1.3.2.1 Definition

This IOC represents the properties of an NDT job demand created by an MnS consumer. An NDT job represents the characteristics (e.g., scope, scenario, etc) for a network simulation/emulation task.

The attribute "ndtJobSynchScope" indicates the scope of the network that should be synchronized into and modelled by the NDT MnSProducer for the specific NDT job.

The attribute "ndtJobScenario" indicates the input that is defined by MnS consumer for the characteristics of network objects that should be simulated/emulated by NDT MnS Producer. If the NDT MnS Producer is able to synchronize with an actual network, the ndtJobScenario indicates the delta between the actual network and twin network that is simulated/emulated. Otherwise, it indicates the critical features that should be modelled, allowing the NDT MnS Producer to use defaults for all other features. The ndtJobScenario can be network configurations or automation functionality configurations, network events, issues that are defined by the MnS consumer and will be sent to the NDT MnS Producer.

The attribute "ndtJobExecutionRequirements" represents requirements related to the execution of network simulation/emulation task for an NDT job, e.g., maximum run time for each simulation/emulation task, precision, etc which are used to select the model parameters (e.g., simulation/emulation step and number of simulation/emulation times) for NDT modelling. It is up to implementation how the NDT modelling is built and used to execute the simulation/emulation task.

NOTE: the model for the specific tasks can be extended as needed.

To support collaboration among NDT Functions, the NDTJob includes the attribute "ndtJobRefList" representing the NDT Job is associated with one or more other NDT Jobs that are contributing to the NDT Collaboration.

6.2.1.3.2.2 Attributes

The NDTJob IOC includes attributes inherited from Top IOC (defined in 3GPP TS 28.622 [7]) and the following attributes.

Table 6.2.1.3.2.2-1

Attribute Name	Support Qualifier	isReadable	isWritable	isInvariant	isNotifiable
ndtCapability	M	T	T	F	T
ndtJobSynchScope	M	T	T	F	T
ndtJobScenario	M	T	T	F	T
ndtJobExecutionRequirements	O	T	T	F	T
Attribute related roles					
ndtReportRefList	M	T	T	F	T
ndtJobRefList	O	T	F	F	T

6.2.1.3.2.3 Attribute constraints

None.

6.2.1.3.2.4 Notifications

The common notifications defined in clauses 6.5 are valid for this IOC.

6.2.1.3.3 NDTFunctionScope << dataType >>

6.2.1.3.3.1 Definition

This dataType represents the properties of a scope that can be modelled by an NDT MnS Producer.

6.2.1.3.3.2 Attributes

The NDTFunctionScope dataType includes the following attributes.

Table 6.2.1.3.3.2-1

Attribute Name	Support Qualifier	isReadable	isWritable	isInvariant	isNotifyable
ndTRANScope	M	T	F	F	T
ndTCNScope	M	T	F	F	T

6.2.1.3.3.3 Attribute constraints

None.

6.2.1.3.3.4 Notifications

The common notifications defined in clauses 6.5 are valid for this dataType.

6.2.1.3.4 NDTInputDescription<<dataType>>

6.2.1.3.4.1 Definition

This dataType represents a description of the specific network scenario represented by the attribute ndtJobScenario. It may be used to describe any of the following:

- aspects of the network that should be modelled in the NDT MnS Producer for a specific NDT Job,
- configurations that should be applied or have been applied by the NDT MnS Producer for a specific NDT Job.

The attribute simulationDataDescriptor describes the simulation details for the NDT.

6.2.1.3.4.2 Attributes

The NDTInputDescription <<datatype>> includes the following attributes.

Table 6.2.1.3.4.2-1

Attribute Name	Support Qualifier	isReadable	isWritable	isInvariant	isNotifyable
ndtInputDescriptionId	M	T	T	F	T
simulationDataDescriptor	O	T	T	F	T
networkEventInfo	O	T	T	F	T

6.2.1.3.4.3 Attribute constraints

None

6.2.1.3.4.4 Notifications

The common notifications defined in clauses 6.5 are valid for this dataType.

6.2.1.3.5 NDTOutputDescription <<dataType>>

6.2.1.3.5.1 Definition

This dataType represents a description of the individual outputs of the NDT Job. It may be used to describe any of the following:

- states of the network that have been modelled and are being reported by the NDT MnS Producer,
- characteristics of the network that are being reported by the NDT MnS Producer.

The objects that have been modelled are described by specific network object instances represented by `objectInstance` and their specific characteristics (PMs, alarms, etc.) listed in `objectAttributeList`.

6.2.1.3.5.2 Attributes

The `NDTOutputDescription` <<datatype>> includes the following attributes.

Table 6.2.1.3.5.2-1

Attribute Name	Support Qualifier	isReadable	isWritable	isInvariant	isNotifyable
<code>nDTOutputDescriptionId</code>	M	T	T	F	T
<code>objectInstance</code>	M	T	T	F	F
<code>objectAttributeList</code>	M	T	T	F	T

6.2.1.3.5.3 Attribute constraints

None

6.2.1.3.5.4 Notifications

The common notifications defined in clauses 6.5 are valid for this dataType.

6.2.1.3.6 ScopeDefinition <<choice>>

6.2.1.3.6.1 Definition

This <<choice>> represents a definition of a scope.

The `managedEntitiesScope` attribute identifies the scope by the DNs of the managed entities.

The `areaScope` attribute identify the scope by the geographical area information.

The `managedEntitiesScope` attribute and `areaScope` attribute shall not be present at the same time.

6.2.1.3.6.2 Attributes

Table 6.2.3.6.2-1

Attribute name	S	isReadable	isWritable	isInvariant	isNotifyable
Choice_1 <code>managedEntitiesScope</code>	CM	T	T	F	T
Choice_2 <code>areaScope</code>	CM	T	T	F	T

6.2.1.3.6.3 Attribute constraints

Table 6.2.1.3.6.3-1

Name	Definition
1 managedEntitiesScope	the MnS producer supports identifying the scope by managed entities.
2 areaScope	the MnS producer supports identifying the scope by geographical area information.

6.2.1.3.6.4 Notifications

None.

6.2.1.3.7 NdtJobExecutionReqs <<dataType>>

6.2.1.3.7.1 Definition

The NdtJobExecutionReqs <<dataType>> represents the execution requirements for NDT job.

6.2.1.3.7.2 Attributes

The NdtJobExecutionReqs includes the following attributes.

Table 6.2.1.3.7.2-1

Attribute Name	Support Qualifier	isReadable	isWritable	isInvariant	isNotifiable
maxRuntime	O	T	T	F	F

6.2.1.3.7.3 Attribute constraints

None

6.2.1.3.7.4 Notifications

The common notifications defined in clauses 6.5 are valid for this dataType.

6.2.1.3.8 NDTReport <<InformationObjectClass>>

6.2.1.3.8.1 Definition

This IOC represents the properties of an NDT report corresponding to an NDT job.

An NDT job may run more than one task at the same time, e.g., a network configuration task and a network response task. The NDTReport contains an output for each task that is executed by the NDT job.

The attribute "NDTJobOutputData" specified performance metrics and/or alarm types that are collected and reported by NDT MnS Producer after the behaviour is modelled in NDT MnS Producer is put in a list for which each entry is an NDTOutputDataPoint.

6.2.1.3.8.2 Attributes

The NDTReport IOC includes attributes inherited from Top IOC (defined in 3GPP TS 28.622 [7]) and the following attributes.

Table 6.2.1.3.8.2-1

Attribute Name	Support Qualifier	isReadable	isWritable	isInvariant	isNotifyable
nDTJobOutputData	M	T	F	F	T
Attribute related roles					
nDTJobRef	M	T	F	F	T

6.2.1.3.8.3 Attribute constraints

None.

6.2.1.3.8.4 Notifications

The common notifications defined in clauses 6.5 are valid for this dataType.

6.2.1.3.9 NDTOutputDataPoint <<dataType>>

6.2.1.3.9.1 Definition

This dataType represents a single output corresponding to the NDT Job.

6.2.1.3.9.2 Attributes

The nDTOutputDataPoint <<datatype>> includes attributes inherited from Top IOC (defined in 3GPP TS 28.622 [7]) and the following attributes.

The nDTOutputDataPoint indicates three different types of information about the network. The networkState indicates the state of the network at which a specific networkConfiguration (i.e. a delta of the network state or new state of the network) is applied. The observations show the outcome on the network when the stated networkConfiguration is applied in the stated networkState.

Table 6.2.1.3.9.2-1

Attribute Name	Support Qualifier	isReadable	isWritable	isInvariant	isNotifyable
networkState	M	T	F	T	T
networkConfiguration	M	T	F	T	T
observations	M	T	F	T	T

6.2.1.3.9.3 Attribute constraints

None.

6.2.1.3.9.4 Notifications

The common notifications defined in clauses 6.5 are valid for this dataType.

6.2.1.3.10 SimulationDataDescriptor <<dataType>>

6.2.1.3.10.1 Definition

This dataType represents the simulation details for the NDT

6.2.1.3.10.2 Attributes

The attribute simulationData defines the management data is to be updated artificially in order to induce a particular network issue. It also defines the network management data that aims to be simulated/emulated by the NDT. The

behaviour can be configurations for verification. The `simulationData` can be network configurations or automation functionality configurations, such as RAN ES functionality provided by SON.

The attribute `Condition` defines the condition that has to be satisfied in order to update the simulation data. This can be defined in terms of location and time.

Table 6.2.1.3.10.2-1

Attribute Name	Support Qualifier	isReadable	isWritable	isInvariant	isNotifyable
<code>simulationData</code>	M	T	F	T	T
<code>condition</code>	M	T	F	T	T

6.2.1.3.10.3 Attribute constraints

None.

6.2.1.3.10.4 Notifications

The common notifications defined in clauses 6.5 are valid for this `dataType`.

6.2.1.3.11 SimulationData <<dataType>>

6.2.1.3.11.1 Definition

This `dataType` defines the management data that is to be updated artificially in order to induce a particular network issue.

6.2.1.3.11.2 Attributes

The attribute `performanceData` defines the performance measurement or KPI name that is to be updated and with what value.

The attribute `mDTData` is defined as attribute/value pair representing the MDT data name that is to be updated and with what value.

The attribute `configurationData` defines the configuration updates for the network.

Table 6.2.1.3.11.2-1

Attribute Name	Support Qualifier	isReadable	isWritable	isInvariant	isNotifyable
<code>performanceData</code>	M	T	F	T	T
<code>mDTData</code>	M	T	F	T	T
<code>configurationData</code>	M	T	F	T	T

6.2.1.3.11.3 Attribute constraints

None.

6.2.1.3.11.4 Notifications

The common notifications defined in clauses 6.5 are valid for this `dataType`.

6.2.1.3.12 PerformanceData <<dataType>>

6.2.1.3.12.1 Definition

This `dataType` describes the performance data injected in NDT to represent network events.

The attribute `performanceDataName` identifies a performance measurement or KPI.

The attribute `performanceDataValue` is used to overwrite values which are synchronized from the real network. Alternatively, `performanceDataScalingFactor` is used to apply a multiplication factor to values which are synchronized from the real network. For example, in the scenario of using NDT to verify the network response to a signalling storm event, the consumer can request to inject the number of UE requests with multiplication factor of 300% in NDT, which represents three times of the number of UE requests in the real network.

6.2.1.3.12.2 Attributes

The `PerformanceData` <<dataType>> includes the following attributes.

Table 6.2.1.3.12.2-1

Attribute Name	Support Qualifier	isReadable	isWritable	isInvariant	isNotifiable
<code>performanceDataName</code>	M	T	T	F	F
CHOICE_1.1 <code>performanceDataValue</code>	CM	T	T	F	F
CHOICE_2.1 <code>performanceDataScalingFactor</code>	CM	T	T	F	F

6.2.1.3.12.3 Attribute constraints

Name	Definition
CHOICE_1.1 <code>performanceDataValue</code>	This attribute shall be supported when the MnS producer supports performance data inputs which shall be configured with a data value.
CHOICE_2.1 <code>performanceDataScalingFactor</code>	This attribute shall be supported when the MnS producer supports performance data inputs which shall be configured with a scaling factor.

6.2.1.3.12.4 Notifications

The notifications specified by the notification subclause of the <<IOC>> using this <<dataType>> are applicable.

6.3 Attribute definitions

6.3.1 Attribute properties

Table 6.3.1-1

Attribute Name	Documentation and Allowed Values	Properties
nDTJobRef	It indicates an DN of a NDTJob instance of an NDTReport instance. allowedValues: N/A	type: DN multiplicity: 1 isOrdered: N/A isUnique: N/A defaultValue: None isNullable: False
nDTJobRefList	It indicates the DN(s) of the NDTJob Instance(s) contributing in the NDT collaboration. This attribute is present for NDT collaboration. allowedValues: N/A	type: DN multiplicity: * isOrdered: False isUnique: True defaultValue: None isNullable: False
nDTFunctionRefList	It indicates the DN(s) of the NDTFunction Instance(s) may contribute in the NDT collaboration. This attribute is present for NDT collaboration. allowedValues: N/A	type: DN multiplicity: * isOrdered: False isUnique: True defaultValue: None isNullable: False
nDTReportRefList	It indicates a list of DN for NDTReport Instances. allowedValues: N/A	type: DN multiplicity: * isOrdered: False isUnique: True defaultValue: None isNullable: False
supportedNDTCapabilities	It indicates the different types of scenario specific capability which the NDT MnS Producer is capable of undertaking. allowedValues: "RISKY_ACTIONS_PREDICTION", "EVENTS_IMPACTS_VERIFICATION", "NETWORK_ISSUE_INDUCEMENT", "NETWORK_EVENTS_VERIFICATION", "NETWORK_CONFIGURATIONS_VERIFICATION", "AUTOMATION_CONFIGURATION_VERIFICATION", "ML_TRAINING_DATA_GENERATION", "USER_EXPERIENCE_DATA_GENERATION" New values can be added to this list in future releases to support new use cases. The meaning of these values is as follows: "RISKY_ACTIONS_PREDICTION" means NDTFunction supports the use case described in 5.2.2.2. "EVENTS_IMPACTS_VERIFICATION" means NDTFunction supports the use case described in 5.2.2.3. "NETWORK_ISSUE_INDUCEMENT" means NDTFunction supports the use case described in 5.2.2.4. "NETWORK_EVENTS_VERIFICATION" means NDTFunction supports the use case described in 5.3.2.2. "NETWORK_CONFIGURATIONS_VERIFICATION" means NDTFunction supports the use case described in 5.3.2.3. "AUTOMATION_CONFIGURATION_VERIFICATION" means NDTFunction supports the use case described in 5.3.2.4. "ML_TRAINING_DATA_GENERATION" means NDTFunction supports the use case described in 5.4.2.2. "USER_EXPERIENCE_DATA_GENERATION" means NDTFunction supports the use case described in 5.4.2.3.	type: ENUM multiplicity: 1..* isOrdered: False isUnique: True defaultValue: None isNullable: False
nDTFunctionScope	It indicates a scope that can be modelled by an NDT MnS Producer.	type: NDTFunctionScope multiplicity: 1 isOrdered: N/A isUnique: N/A defaultValue: None isNullable: False

nDTCapability	It indicates the type of application use cases that is desired to be executed. allowedValues: Refer to allowedValues for attribute supportedNDTCapabilities	type: ENUM multiplicity: 1 isOrdered: N/A isUnique: N/A defaultValue: None isNullable: False
nDTRANScope	It indicates the scope of the RAN that can be modelled by the NDT MnS Producer	type: ScopeDefinition multiplicity: * isOrdered: False isUnique: True defaultValue: None isNullable: False
nDTCNScope	It indicates the scope of the CN that can be modelled by the NDT MnS Producer.	type: ScopeDefinition multiplicity: * isOrdered: False isUnique: True defaultValue: None isNullable: False
ndTJobSynchScope	It indicates the scope of the network that should be synchronized into and modelled by the NDT MnS Producer for the specific NDT job.	type: ScopeDefinition multiplicity: * isOrdered: False isUnique: True defaultValue: None isNullable: False
ndtJobScenario	It indicates a network scenario that should be modelled in the NDTJob as an extra beyond what is synchronized from the network. The ndtJobScenario can be used for <ul style="list-style-type: none"> - Verification of network response to one or more events - evaluation of the impact of one or more failure events, e.g. a signalling storm - Evaluating one or more network issues, e.g. a coverage issue. The network issues involve one or more network events. - Evaluation of high-risk network operations which are listed within the planned configuration - Verification of network configurations which are listed within the planned configuration - Generation of ML training data - Generation user experience data - Inducing particular issue in the network 	type: NDTInputDescription multiplicity: * isOrdered: False isUnique: True defaultValue: None isNullable: False
nDTInputDescriptionId	It indicates the identifier for a specific input to be modelled in the NDTJob	type: string multiplicity: 1 isOrdered: N/A isUnique: N/A defaultValue: None isNullable: False
nDTOutputDescriptionId	It indicates the identifier for a specific output provided as outcomes of the NDTJob.	type: string multiplicity: 1 isOrdered: N/A isUnique: N/A defaultValue: None isNullable: False

networkEventInfo	<p>This defines the information related with a network event (a provisioning, performance measurement, KPI or fault/ alarm event) that can be introduced by the NDT MnS Producer.</p> <p>The networkEventInfo can be used for</p> <ul style="list-style-type: none"> - Verification of network response to one or more events - evaluation of the impact of one or more failure events, e.g. a signalling storm - Evaluating one or more network issues, e.g. a coverage issue. The network issues involve one or more network events. 	<p>Type: string multiplicity: * isOrdered: False isUnique: True defaultValue: None isNullable: False</p>
simulationDataDescriptor	<p>This defines the simulation details for the NDT Job.</p>	<p>type: SimulationDataDescriptor multiplicity: * isOrdered: False isUnique: True defaultValue: None isNullable: False</p>
simulationData	<p>This described the management data that need to be updated artificially in order to induce a particular network issue.</p> <p>It also defines the network management data that aims to be simulated/emulated by the NDT Job. The behaviour can be configurations for verification. The simulationData can be network configurations or automation functionality configurations, such as RAN ES functionality provided by SON.</p>	<p>type: SimulationData multiplicity: 1 isOrdered: N/A isUnique: N/A defaultValue: None isNullable: False</p>
condition	<p>This will define the condition that has to be satisfied in order to update the simulation data for the task that is executed by the NDT MnS Producer. This can be defined in terms of location and time.</p> <p>This will be the DN of ConditionMonitor[7].</p>	<p>type: DN multiplicity: 1 isOrdered: N/A isUnique: N/A defaultValue: None isNullable: False</p>
performanceData	<p>This defines the performance data injected in NDT Job to represent network events.</p>	<p>type: PerformanceData multiplicity: 1 ..* isOrdered: False isUnique: True defaultValue: None isNullable: False</p>
mDTData	<p>This defines attribute/value pair representing the MDT data name that is to be updated and with what value.</p>	<p>type: AttributeValuePair multiplicity: 1 ..* isOrdered: False isUnique: True defaultValue: None isNullable: False</p>
configurationData	<p>This defines the configuration updates for the network</p>	<p>type: AttributeValuePair multiplicity: 1 ..* isOrdered: False isUnique: True defaultValue: None isNullable: False</p>
performanceDataName	<p>It indicates the name of performance measurement or the KPI as defined in 3GPP TS 28.552 [2] and 3GPP TS 28.554 [3].</p>	<p>type: string multiplicity: 1 isOrdered: N/A isUnique: N/A defaultValue: None isNullable: False</p>

performanceDataValue	It indicates the value of performance data.	type: Integer multiplicity: 1 isOrdered: N/A isUnique: N/A defaultValue: None isNullable: False
performanceDataScalingFactor	It indicates the percentage of scaling for performance data. A scaling factor less than 100% indicates a reduction in the performance data, a scaling factor greater than 100% indicates an increase in the performance data.	type: Integer multiplicity: 1 isOrdered: N/A isUnique: N/A defaultValue: None isNullable: False
ndtJobExecutionRequirements	It describes the performance requirements for simulation/emulation by NDT MnS Producer, e.g., maximum run time for each simulation/emulation job, precision, etc.	type: NdtJobExecutionReqt multiplicity: 1 isOrdered: N/A isUnique: N/A defaultValue: None isNullable: False
ndtJobOutputData	It indicates the list of NDTOutputDataPoint(s) that are provided by the NDT MnS Producer as the output for any task executed in an instantiated NDT job.	type: NDTOutputDataPoint multiplicity: 1..* isOrdered: False isUnique: True defaultValue: None isNullable: False
maxRuntime	Maximum run time for each simulation task executed by the NDT MnS Producer. The unit is second.	type: Integer multiplicity: 1 isOrdered: N/A isUnique: N/A defaultValue: None isNullable: False
networkState	It indicates a state of the twin network (the modelled network by the NDT MnS Producer) for which a configuration or reconfiguration is applied. The networkState is the description of what exists in the network at the time when the networkConfiguration is made.	type: NDTOutputDescription multiplicity: * isOrdered: False isUnique: True defaultValue: None isNullable: False
networkConfiguration	It indicates a network configuration that is executed according to the NDT Job and being reported in the NDT report.	type: NDTOutputDescription multiplicity: * isOrdered: False isUnique: True defaultValue: None isNullable: False
observations	It indicates an impact on the network. It shows the list of network objects that are affected and the effects on the specific objects.	type: NDTOutputDescription multiplicity: * isOrdered: False isUnique: True defaultValue: None isNullable: False
objectInstance	It indicates the MOI contained in the NDT report.	type: DN multiplicity: 1 isOrdered: N/A isUnique: N/A defaultValue: None isNullable: False

objectAttributeList	It indicates the key-value pair of the characteristics of the MOI.	type: AttributeValuePair multiplicity: * isOrdered: False isUnique: True defaultValue: None isNullable: False
managedEntitiesScope	A list of DN of managed entities which is the NDT modelling scope.	type: DN multiplicity: * isOrdered: False isUnique: True defaultValue: None isNullable: False
areaScope	Geographical area which is the NDT modelling scope.	type: GeoArea multiplicity: * isOrdered: False isUnique: True defaultValue: None isNullable: False

6.4 Procedure for NDT management

6.4.1 Procedure for consuming NDT management service

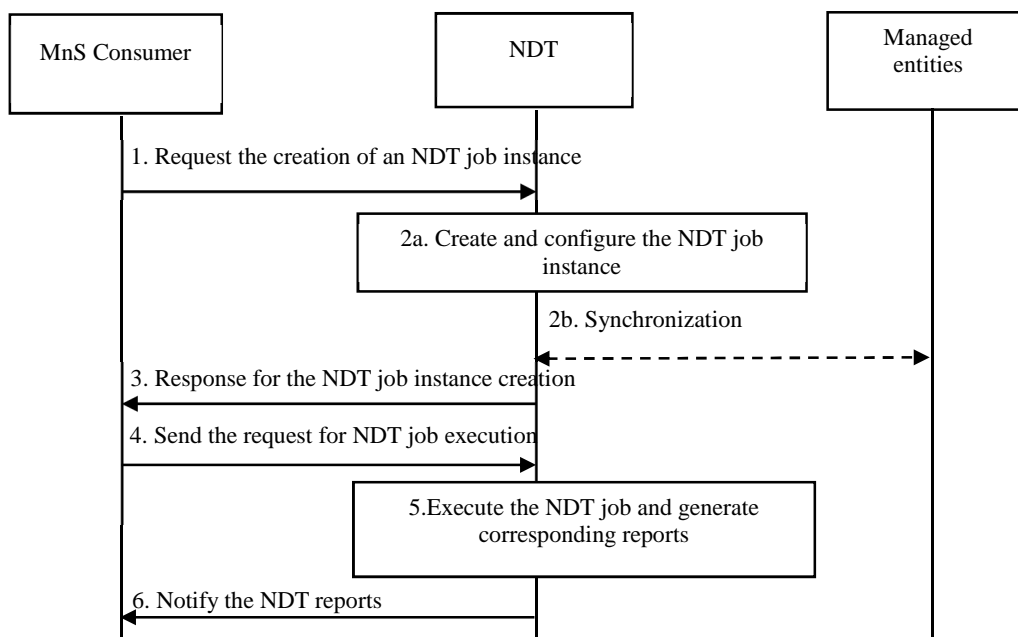

Figure 6.4.1-1: Procedure of consuming NDT management service

1. NDT MnS Producer receives a request from NDT MnS consumer to create an NDT job instance (see createMOI operation defined in TS 28.532 [8]) which represents the consumer’s requirements for the NDT job. In the request to create the NDT job instance, the nDTCapability is specified to trigger scenario specific NDT job, e.g., signalling storm analysis, network configuration verification, data generation, etc. The request further includes nDTJobSynchScope indicating the scope of NDT job (e.g., simulated network objects such as network functions, S-NSSAI).

2a. NDT MnS Producer creates and configures the NDT job instance according to the request from MnS consumer.

2b. NDT MnS Consumer synchronizes the simulated network objects related information from managed entities for NDT job modelling and validation.

3. NDT MnS Producer sends a response (see createMOI operation defined in TS 28.532[8]) to the NDT MnS Consumer.
4. NDT MnS Consumer sends the request to NDT MnS Producer to start the execution of the NDT job instance.
5. NDT MnS Producer executes the NDT job, creates an NDTReport instance (i.e., the instance of NDTReport IOC) and configures NDTReport MOI according to the modelling results.
6. NDT MnS Producer notifies the NDT report to MnS consumer to indicate the network simulation/emulation results.

6.4.2 Procedure for delete an NDT job

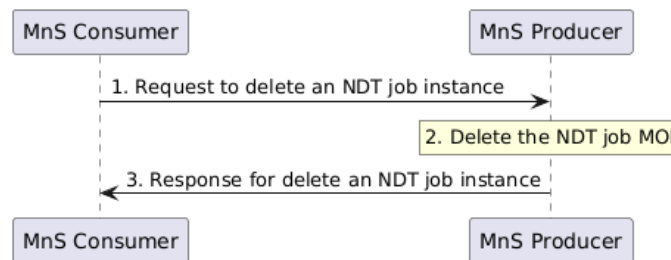

Figure 6.4.2-1: Procedure for delete an NDT job

1. MnS Consumer sends a request to delete an NDT job instance (see deleteMOI operation defined in TS 28.532 [8]) to MnS Producer with 'objectInstance' of the NDT job MOI.
2. Based on the request, MnS Producer deletes the NDT job MOI.
3. MnS Producer sends response (see deleteMOI operation defined in TS 28.532 [8]) to the MnS consumer with status (OperationSucceeded or OperationFailed) and 'objectInstance' of the deleted NDT job MOI.

6.4.3 Procedure for query an NDT job

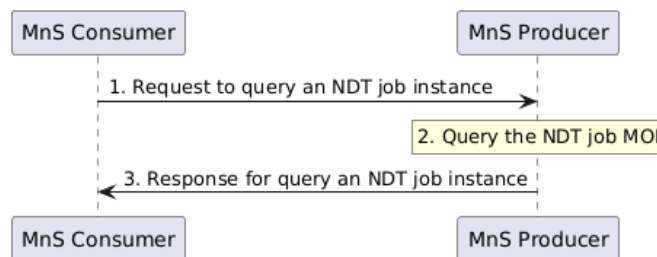

Figure 6.4.3-1: Procedure for query an NDT job

1. MnS Consumer sends a request to query an NDT job instance (see getMOIAttributes operation defined in TS 28.532 [8]) to MnS Producer with 'objectInstance' of the existing NDT job MOI and list of attribute names of NDT job IOC. The list of attribute names identifies the attributes to be returned by this operation.
2. Based on the request, the MnS Producer queries the concrete NDT job MOI.
3. MnS Producer sends a response (see getMOIAttributes operation defined in TS 28.532 [8]) to the MnS consumer with 'objectClass', 'objectInstance', and list of [Attribute,Value] which is defined in clause 6.2.

6.5 Common notifications

6.5.1 Configuration notifications

This clause presents a list of notifications, defined in TS 28.532 [8], that an MnS consumer may receive. The notification header attribute `objectClass/objectInstance` shall capture the DN of an instance of a class defined in the present document.

Table 6.5.1-1

Name	Qualifier	Notes
<code>notifyMOICreation</code>	O	--
<code>notifyMOIDeletion</code>	O	--
<code>notifyMOIAttributeValueChanges</code>	O	--
<code>notifyEvent</code>	O	--

7 Management service for NDT (stage 3)

7.1 RESTful HTTP-based solution set

The RESTful HTTP-based solution set for generic provisioning management service is defined in clause 12.1.1 in 3GPP TS 28.532 [8]. Corresponding `className` is `NDTFunction`, `NDTJob` and `NDTReport`.

Following is the SS to support NDT function management based on Table 12.1.1.1.1-1 in TS 28.532 [8].

Table 7.1-1: SS to support NDT function management

NDT lifecycle management	IS operation	HTTP Method	Resource URI
Query an NDT function	<code>getMOIAttributes</code> operation	GET	<code>{MnSRoot}/ProvMnS/{MnSVersion}/{URI-LDN-first-part}/{NDTFunction}={id}</code>

Following is the SS to support NDT job management based on Table 12.1.1.1.1-1 in TS 28.532 [8].

Table 7.1-2: SS to support NDT job management

NDT job management	IS operation	HTTP Method	Resource URI
Create an NDT job	<code>createMOI</code> operation	POST	<code>{MnSRoot}/ProvMnS/{MnSVersion}/{URI-LDN-first-part}</code>
Delete an NDT job	<code>deleteMOI</code> operation	DELETE	<code>{MnSRoot}/ProvMnS/{MnSVersion}/{URI-LDN-first-part}/{NDTJob}={id}</code>
Modify an NDT job	<code>modifyMOIAttributes</code> operation	PUT PATCH	<code>{MnSRoot}/ProvMnS/{MnSVersion}/{URI-LDN-first-part}/{NDTJob}={id}</code>
Query an NDT job	<code>getMOIAttributes</code> operation	GET	<code>{MnSRoot}/ProvMnS/{MnSVersion}/{URI-LDN-first-part}/{NDTJob}={id}</code>

Following is the SS to support NDT report management based on Table 12.1.1.1.1-1 and Table 12.1.1.2.1-1 in TS 28.532 [8].

Table 7.1-3: SS to support NDT report management

NDT report management	IS operation	HTTP Method	Resource URI
Query an NDT report	getMOIAttributes operation	GET	{MnSRoot}/ProvMnS/{MnSVersion}/{URI-LDN-first-part}/{NDTReport}={id}
Subscribe an NDT report	createMOI operation	POST	{MnSRoot}/ProvMnS/{MnSVersion}/{URI-LDN-first-part}
Notify an NDT report	notifyMOIAttributeValueChanges notification	POST	{notificationTarget}
Unsubscribe an NDT report	deleteMOI operation	DELETE	{MnSRoot}/ProvMnS/{MnSVersion}/{URI-LDN-first-part}/{NtfSubscriptionControl}={id}
Query an NDT report subscription	getMOIAttributes operation	GET	{MnSRoot}/ProvMnS/{MnSVersion}/{URI-LDN-first-part}/{NtfSubscriptionControl}={id}

NOTE: The NtfSubscriptionControl is defined in TS 28.622 [7].

Annex A (informative): PlantUML source code

A.1 Information model definition for NDT

A.1.1 Relationship UML diagram for NDT management

```
@startuml
hide empty members
skinparam ClassStereotypeFontStyle normal
hide circle
skinparam class {
  BackgroundColor White
  ArrowColor Black
  BorderColor Black
}
skinparam linetype ortho
'skinparam BoxPadding 40
skinparam nodesep 2
class ManagedEntity <<ProxyClass>>
class NDTFunction <<InformationObjectClass>>
class NDTJob <<InformationObjectClass>>
class NDTReport <<InformationObjectClass>>
note right of ManagedEntity
  Represents SubNetwork
end note
ManagedEntity "1" *-- "*" NDTFunction: <<names>>
NDTFunction "1" *-- "*" NDTJob: <<names>>
NDTFunction "1" *-- "*" NDTReport: <<names>>
NDTJob "1" <--> "*" NDTReport
@enduml
```

A.1.2 Inheritance UML diagram for NDT management

```
@startuml
skinparam ClassStereotypeFontStyle normal
skinparam ClassBackgroundColor White
skinparam shadowing false
skinparam monochrome true
hide members
hide circle

class Top << InformationObjectClass >>
class ManagedFunction << InformationObjectClass >>
class NDTFunction <<InformationObjectClass>>
class NDTJob <<InformationObjectClass>>
class NDTReport <<InformationObjectClass>>

ManagedFunction <|-- NDTFunction
Top <|-- NDTJob
Top <|-- NDTReport

@enduml
```

A.2 Procedure for NDT management

A.2.1 Procedure for delete an NDT job

```
@startuml
participant "MnS Consumer" as MNSC
participant "MnS Producer" as MNSP

MNSC -> MNSP: 1. Request to delete an NDT job instance
rnote over MNSP
  2. Delete the NDT job MOI
endrnote
@enduml
```

```
MNSP -> MNSC: 3. Response for delete an NDT job instance
```

```
@enduml
```

A.2.2 Procedure for query an NDT job

```
@startuml
```

```
participant "MnS Consumer" as MNSC
```

```
participant "MnS Producer" as MNSP
```

```
MNSC -> MNSP: 1. Request to query an NDT job instance
```

```
rnote over MNSP
```

```
2. Query the NDT job MOI
```

```
endnote
```

```
MNSP -> MNSC: 3. Response for query an NDT job instance
```

```
@enduml
```

Annex B (informative): NDT function in different domains

B.1 NDT function in RAN domain

The NDT function is provided by the RAN management domain to support RAN domain simulation/emulation capability. For instance, the NDT function in RAN domain is responsible for RAN energy saving configuration verification as introduced in clause 5.3.2.4. Figure B.1-1 depicts the scenario when NDT function is deployed in RAN domain.

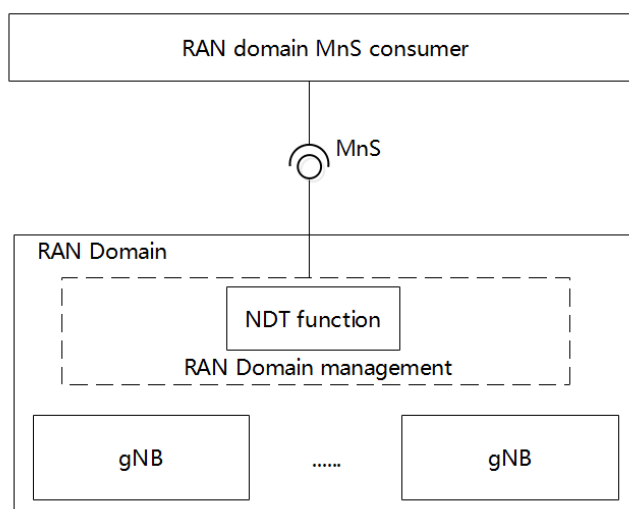

Figure B.1-1: NDT function in RAN domain management

B.2 NDT function in cross domain

The NDT function is provided by the cross management domain to support cross-domain simulation/emulation capability. For instance, the NDT function in cross-domain is responsible for synthetic user experience data generation as introduced in clause 5.4.2.3. Figure B.2-1 depicts the scenario when NDT function is deployed in cross-domain. The cross management domain is introduced in TS 28.533.

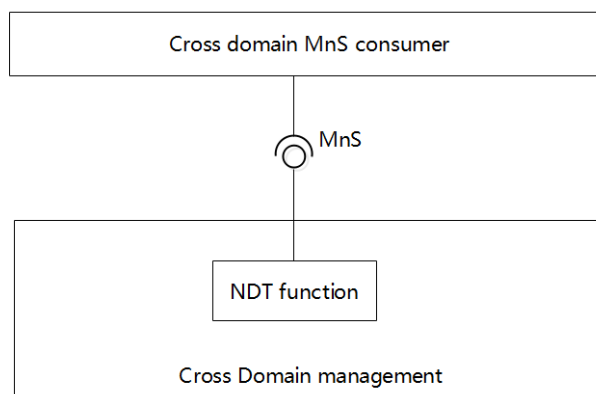

Figure B.2-1: NDT function in cross-domain management

Annex C (informative): Change history

Change history							
Date	Meeting	TDoc	CR	Rev	Cat	Subject/Comment	New version
2025-02	SA5#159	S5-250782				pCR 28.561 Add skeleton pCR 28.561 Add scope pCR 28.561 Add the term and concepts of NDT Rel-19 pCR TS 28.561 Add the Role of NDT in the Management Loop pCR TS28.561 NDT support to Automation pCR TS28.561 NDT LCM use case pCR Add UC of using NDT to generate ML training data for TS 28.561	0.1.0
2025-04	SA5#160	S5-251759				TS28.561 Add the NDT concept and scope TS28.561 NDT support for network automation Pseudo-CR on NDTs for verification Pseudo-CR on TS 28.561 Add requirements for NDT supporting data generation Rel-19 pCR TS 28.561 General improvements to use cases and requirements Pseudo-CR on TS 28.561 NDT NRMs Pseudo-CR on TS 28.561 Procedure for consuming NDT capability Pseudo-CR on TS 28.561 Nested -NDT Definition	0.2.0
2025-05	SA5#161	S5-252821				Rel-19 pCR TS 28.561 Add authorization to all requirement Pseudo-CR on TS 28.561 NDT Procedure update Rel-19 pCR TS 28.561 Add procedures for delete and query an NDT job Pseudo-CR on TS 28.561 NDT Use case Update Rel-19 pCR TS 28.561 Deployment scenarios of NDT function Pseudo-CR on NRM for Collaboration between NDTs Pseudo-CR on General NRM for NDTs	0.3.0
2025-05	SA#108	SP-250493				Presentation to TSG SA for Information	1.0.0
2025-08	SA5#162	S5-254116				Rel-19 pCR on TS 28.561 Rapporteur clean-up Rel-19 pCR TS 28.561 Stage 3 of NDT NRM Rel-19 pCR TS 28.561 Add RESTful HTTP-based solution set for NDT Rel-19 pCR TS 28.561 Clarification on collaborating NDT Rel-19 pCR TS 28.561 Clarification on the usage of NDT in stage 2 Rel-19 pCR TS 28.561 Update description for NDT supporting network automation Rel-19 pCR TS 28.561 Update NDT NRM to solve misalignment Rel-19 pCR 28.561 Updates regarding Network Issue Inducement Rel-19 pCR TS 28.561 Update on the NDT Procedure Rel-19 pCR on TS 28.561 Update NDT concept (relation to automation and LCM) Rel-19 pCR TS 28.561 Update the overview of NDT Clarify NDT management service Clarify simulation and emulation in 4.1 Rel-19 pCR TS 28.561 Update NDT data generation Clarify support for data generation Clarify evaluation of high-risk operation Clarify NDT definition and collaborative NDT use case Rel-19 pCR TS 28.561 Update the use case in 5.2.2.2, 5.3.2.2, 5.4.2.3 Rel-19 pCR TS 28.561 Update reference and abbreviations	1.1.0
2025-08	SA#109	SP-251035				Presentation to TSG SA for Approval	2.0.0
2025-09	SA#109					Upgrade to change control version	19.0.0
2025-12	SA#110	SP-251384	0001	1	F	Rel-19 CR TS 28.561 Correct Inconsistency between Stage 2 and Stage 3	19.1.0
2025-12	SA#110	SP-251384	0002	1	F	Rel-19 CR TS 28.561 Correction on NDT Attributes	19.1.0
2025-12	SA#110	SP-251384	0003	1	F	Rel-19 CR TS 28.561 editorial corrections and clarifications	19.1.0
2025-12	SA#110	SP-251384	0004	2	F	Rel-19 CR TS 28.561 Make NDTDataValue and NDTScalingFactor as conditional mandatory attributes	19.1.0
2025-12	SA#110	SP-251384	0007	1	F	Rel-19 CR TS 28.561 Fix stage 2 and stage 3 for SimulationDataDescriptor	19.1.0
2025-12	SA#110	SP-251384	0010	1	F	Rel-19 CR TS 28.561 Fix conflict between attributes	19.1.0
2025-12	SA#110	SP-251384	0011		F	Rel-19 CR TS 28.561 Fix errors in attribute definitions	19.1.0
2025-12	SA#110	SP-251384	0012	1	F	Rel-19 CR TS 28.561 Fix problems with imported IOCs	19.1.0
2025-12	SA#110	SP-251384	0013	1	F	Rel-19 CR TS 28.561 Fix procedure for consuming NDT	19.1.0
2025-12	SA#110	SP-251384	0014		B	Rel-19 CR TS 28.561 Correction on NDT text descriptions	19.1.0
2026-01	SA#110					MCC: added missing yaml file	19.1.1

History

Version	Date	Status
V19.0.0	October 2025	Publication
V19.1.1	February 2026	Publication