

# ETSI TS 129 256 V19.4.0 (2026-02)



**TECHNICAL SPECIFICATION**

**5G;  
Uncrewed Aerial Systems Network Function (UAS-NF);  
Aerial Management Services;  
Stage 3  
(3GPP TS 29.256 version 19.4.0 Release 19)**



---

**Reference**

RTS/TSGC-0429256vj40

---

**Keywords**

5G

**ETSI**

650 Route des Lucioles  
F-06921 Sophia Antipolis Cedex - FRANCE

---

Tel.: +33 4 92 94 42 00 Fax: +33 4 93 65 47 16

Siret N° 348 623 562 00017 - APE 7112B  
Association à but non lucratif enregistrée à la  
Sous-Préfecture de Grasse (06) N° w061004871

---

**Important notice**

The present document can be downloaded from the  
[ETSI Search & Browse Standards](#) application.

The present document may be made available in electronic versions and/or in print. The content of any electronic and/or print versions of the present document shall not be modified without the prior written authorization of ETSI. In case of any existing or perceived difference in contents between such versions and/or in print, the prevailing version of an ETSI deliverable is the one made publicly available in PDF format on [ETSI deliver](#) repository.

Users should be aware that the present document may be revised or have its status changed, this information is available in the [Milestones listing](#).

If you find errors in the present document, please send your comments to the relevant service listed under [Committee Support Staff](#).

If you find a security vulnerability in the present document, please report it through our [Coordinated Vulnerability Disclosure \(CVD\)](#) program.

---

**Notice of disclaimer & limitation of liability**

The information provided in the present deliverable is directed solely to professionals who have the appropriate degree of experience to understand and interpret its content in accordance with generally accepted engineering or other professional standard and applicable regulations.

No recommendation as to products and services or vendors is made or should be implied.

No representation or warranty is made that this deliverable is technically accurate or sufficient or conforms to any law and/or governmental rule and/or regulation and further, no representation or warranty is made of merchantability or fitness for any particular purpose or against infringement of intellectual property rights.

In no event shall ETSI be held liable for loss of profits or any other incidental or consequential damages.

Any software contained in this deliverable is provided "AS IS" with no warranties, express or implied, including but not limited to, the warranties of merchantability, fitness for a particular purpose and non-infringement of intellectual property rights and ETSI shall not be held liable in any event for any damages whatsoever (including, without limitation, damages for loss of profits, business interruption, loss of information, or any other pecuniary loss) arising out of or related to the use of or inability to use the software.

---

**Copyright Notification**

No part may be reproduced or utilized in any form or by any means, electronic or mechanical, including photocopying and microfilm except as authorized by written permission of ETSI.

The content of the PDF version shall not be modified without the written authorization of ETSI.

The copyright and the foregoing restriction extend to reproduction in all media.

© ETSI 2026.  
All rights reserved.

---

# Intellectual Property Rights

## Essential patents

IPRs essential or potentially essential to normative deliverables may have been declared to ETSI. The declarations pertaining to these essential IPRs, if any, are publicly available for **ETSI members and non-members**, and can be found in ETSI SR 000 314: "*Intellectual Property Rights (IPRs); Essential, or potentially Essential, IPRs notified to ETSI in respect of ETSI standards*", which is available from the ETSI Secretariat. Latest updates are available on the [ETSI IPR online database](#).

Pursuant to the ETSI Directives including the ETSI IPR Policy, no investigation regarding the essentiality of IPRs, including IPR searches, has been carried out by ETSI. No guarantee can be given as to the existence of other IPRs not referenced in ETSI SR 000 314 (or the updates on the ETSI Web server) which are, or may be, or may become, essential to the present document.

## Trademarks

The present document may include trademarks and/or tradenames which are asserted and/or registered by their owners. ETSI claims no ownership of these except for any which are indicated as being the property of ETSI, and conveys no right to use or reproduce any trademark and/or tradename. Mention of those trademarks in the present document does not constitute an endorsement by ETSI of products, services or organizations associated with those trademarks.

**DECT™**, **PLUGTESTS™**, **UMTS™** and the ETSI logo are trademarks of ETSI registered for the benefit of its Members. **3GPP™**, **LTE™** and **5G™** logo are trademarks of ETSI registered for the benefit of its Members and of the 3GPP Organizational Partners. **oneM2M™** logo is a trademark of ETSI registered for the benefit of its Members and of the oneM2M Partners. **GSM®** and the GSM logo are trademarks registered and owned by the GSM Association.

---

# Legal Notice

This Technical Specification (TS) has been produced by ETSI 3rd Generation Partnership Project (3GPP).

The present document may refer to technical specifications or reports using their 3GPP identities. These shall be interpreted as being references to the corresponding ETSI deliverables.

The cross reference between 3GPP and ETSI identities can be found at [3GPP to ETSI numbering cross-referencing](#).

---

# Modal verbs terminology

In the present document "**shall**", "**shall not**", "**should**", "**should not**", "**may**", "**need not**", "**will**", "**will not**", "**can**" and "**cannot**" are to be interpreted as described in clause 3.2 of the [ETSI Drafting Rules](#) (Verbal forms for the expression of provisions).

"**must**" and "**must not**" are **NOT** allowed in ETSI deliverables except when used in direct citation.

# Contents

Intellectual Property Rights .....	2
Legal Notice .....	2
Modal verbs terminology.....	2
Foreword.....	5
1 Scope .....	7
2 References .....	7
3 Definitions of terms, symbols and abbreviations .....	8
3.1 Terms.....	8
3.2 Symbols.....	8
3.3 Abbreviations .....	8
4 Overview .....	8
4.1 Introduction .....	8
5 Services offered by the NEF (UAS-NF) .....	9
5.1 Introduction .....	9
5.2 Nnef_Authentication Service .....	9
5.2.1 Service Description.....	9
5.2.2 Service Operations.....	10
5.2.2.1 Introduction.....	10
5.2.2.2 AuthenticateAuthorize Service Operation.....	10
5.2.2.2.1 General .....	10
5.2.2.3 AuthNotify Service Operation .....	11
5.2.2.3.1 General .....	11
6 API Definitions .....	13
6.1 Nnef_Authentication Service API.....	13
6.1.1 Introduction.....	13
6.1.2 Usage of HTTP.....	13
6.1.2.1 General .....	13
6.1.2.2 HTTP standard headers .....	13
6.1.2.2.1 General .....	13
6.1.2.2.2 Content type .....	13
6.1.2.3 HTTP custom headers .....	13
6.1.3 Resources.....	14
6.1.3.1 Overview.....	14
6.1.3.2 Resource: uav-authentications.....	14
6.1.3.2.1 Description .....	14
6.1.3.2.2 Resource Definition.....	14
6.1.3.2.3 Resource Standard Methods .....	14
6.1.3.2.3.1 POST.....	14
6.1.3.2.4 Resource Custom Operations .....	16
6.1.5 Notifications .....	16
6.1.5.1 General .....	16
6.1.5.2 Authentication Notification.....	16
6.1.5.2.1 Description .....	16
6.1.5.2.2 Target URI.....	16
6.1.5.2.3 Standard Methods.....	16
6.1.6 Data Model .....	17
6.1.6.1 General .....	17
6.1.6.2 Structured data types .....	18
6.1.6.2.1 Introduction .....	18
6.1.6.2.2 Type: UAVAuthInfo .....	19
6.1.6.2.3 Type: AuthNotification .....	21
6.1.6.2.4 Type: UAVAuthResponse.....	22

6.1.6.2.5	Type: UAVAuthFailure .....	23
6.1.6.2.6	Type: AuthContainer .....	23
6.1.6.3	Simple data types and enumerations .....	23
6.1.6.3.1	Introduction .....	23
6.1.6.3.2	Simple data types.....	24
6.1.6.3.3	Enumeration: AuthResult .....	24
6.1.6.3.4	Enumeration: NotifType.....	24
6.1.7	Error Handling .....	24
6.1.7.1	General .....	24
6.1.7.2	Protocol Errors .....	24
6.1.7.3	Application Errors.....	24
6.1.8	Feature negotiation .....	25
6.1.9	Security .....	25
6.1.10	HTTP redirection .....	25
<b>Annex A (normative): OpenAPI specification .....</b>		<b>26</b>
A.1	General .....	26
A.2	Nnef_Authentication API.....	26
<b>Annex B (informative): Change history .....</b>		<b>30</b>
History .....		31

---

# Foreword

This Technical Specification has been produced by the 3rd Generation Partnership Project (3GPP).

The contents of the present document are subject to continuing work within the TSG and may change following formal TSG approval. Should the TSG modify the contents of the present document, it will be re-released by the TSG with an identifying change of release date and an increase in version number as follows:

Version x.y.z

where:

- x the first digit:
  - 1 presented to TSG for information;
  - 2 presented to TSG for approval;
  - 3 or greater indicates TSG approved document under change control.
- y the second digit is incremented for all changes of substance, i.e. technical enhancements, corrections, updates, etc.
- z the third digit is incremented when editorial only changes have been incorporated in the document.

In the present document, modal verbs have the following meanings:

- shall** indicates a mandatory requirement to do something
- shall not** indicates an interdiction (prohibition) to do something

The constructions "shall" and "shall not" are confined to the context of normative provisions, and do not appear in Technical Reports.

The constructions "must" and "must not" are not used as substitutes for "shall" and "shall not". Their use is avoided insofar as possible, and they are not used in a normative context except in a direct citation from an external, referenced, non-3GPP document, or so as to maintain continuity of style when extending or modifying the provisions of such a referenced document.

- should** indicates a recommendation to do something
- should not** indicates a recommendation not to do something
- may** indicates permission to do something
- need not** indicates permission not to do something

The construction "may not" is ambiguous and is not used in normative elements. The unambiguous constructions "might not" or "shall not" are used instead, depending upon the meaning intended.

- can** indicates that something is possible
- cannot** indicates that something is impossible

The constructions "can" and "cannot" are not substitutes for "may" and "need not".

- will** indicates that something is certain or expected to happen as a result of action taken by an agency the behaviour of which is outside the scope of the present document
- will not** indicates that something is certain or expected not to happen as a result of action taken by an agency the behaviour of which is outside the scope of the present document
- might** indicates a likelihood that something will happen as a result of action taken by some agency the behaviour of which is outside the scope of the present document

**might not** indicates a likelihood that something will not happen as a result of action taken by some agency the behaviour of which is outside the scope of the present document

In addition:

**is** (or any other verb in the indicative mood) indicates a statement of fact

**is not** (or any other negative verb in the indicative mood) indicates a statement of fact

The constructions "is" and "is not" do not indicate requirements.

---

# 1 Scope

The present document specifies the stage 3 protocol and data model for the UAS-NF functionality of the Nnef Service Based Interface. It provides stage 3 protocol definitions and message flows, and specifies the API for each service offered by the NEF (UAS-NF).

The 5G System stage 2 architecture and procedures are specified in 3GPP TS 23.501 [2] and 3GPP TS 23.502 [3].

The Technical Realization of the Service Based Architecture and the Principles and Guidelines for Services Definition are specified in 3GPP TS 29.500 [4] and 3GPP TS 29.501 [5].

The Uncrewed Aerial System Network Function (UAS-NF) provides the UAS-specific NEF services to NF service consumers (e.g. AMF, SMF). The UAS-NF is functionality within the NEF.

---

# 2 References

The following documents contain provisions which, through reference in this text, constitute provisions of the present document.

- References are either specific (identified by date of publication, edition number, version number, etc.) or non-specific.
- For a specific reference, subsequent revisions do not apply.
- For a non-specific reference, the latest version applies. In the case of a reference to a 3GPP document (including a GSM document), a non-specific reference implicitly refers to the latest version of that document *in the same Release as the present document*.

- [1] 3GPP TR 21.905: "Vocabulary for 3GPP Specifications".
- [2] 3GPP TS 23.501: "System Architecture for the 5G System; Stage 2".
- [3] 3GPP TS 23.502: "Procedures for the 5G System; Stage 2".
- [4] 3GPP TS 29.500: "5G System; Technical Realization of Service Based Architecture; Stage 3".
- [5] 3GPP TS 29.501: "5G System; Principles and Guidelines for Services Definition; Stage 3".
- [6] 3GPP TS 23.256: "Support of Uncrewed Aerial Systems (UAS) connectivity, identification and tracking; Stage 2".
- [7] 3GPP TR 21.900: "Technical Specification Group working methods".
- [8] IETF RFC 9113: "HTTP/2".
- [9] OpenAPI Initiative, "OpenAPI 3.0.0 Specification", <https://github.com/OAI/OpenAPI-Specification/blob/master/versions/3.0.0.md>.
- [10] IETF RFC 8259: "The JavaScript Object Notation (JSON) Data Interchange Format".
- [11] IETF RFC 9457: "Problem Details for HTTP APIs".
- [12] 3GPP TS 33.501: "Security architecture and procedures for 5G system".
- [13] IETF RFC 6749: "The OAuth 2.0 Authorization Framework".
- [14] 3GPP TS 29.510: "Network Function Repository Services; Stage 3".
- [15] 3GPP TS 29.571: "5G System; Common Data Types for Service Based Interfaces; Stage 3".
- [16] 3GPP TS 24.501: "Non-Access-Stratum (NAS) protocol for 5G System (5GS); Stage 3".
- [17] 3GPP TS 29.522: "5G System; Network Exposure Function Northbound APIs; Stage 3".

---

## 3 Definitions of terms, symbols and abbreviations

### 3.1 Terms

For the purposes of the present document, the terms given in 3GPP TR 21.905 [1] and the following apply. A term defined in the present document takes precedence over the definition of the same term, if any, in 3GPP TR 21.905 [1].

For the purposes of the present document, the terms and definitions given in 3GPP TS 23.256 [6] shall apply.

### 3.2 Symbols

For the purposes of the present document, the following symbols apply:

### 3.3 Abbreviations

For the purposes of the present document, the abbreviations given in 3GPP TR 21.905 [1] and the following apply. An abbreviation defined in the present document takes precedence over the definition of the same abbreviation, if any, in 3GPP TR 21.905 [1].

AA	Authorization/Authentication
BRID	Broadcast Remote Identification
BVLOS	Beyond Visual Line of Sight
C2	Command and Control
NRID	Networked Remote Identification
PEI	Permanent Equipment Identifier
RID	Remote Identification
TPAE	Third Party Authorized Entity
UAS	Uncrewed Aerial System
UAV	Uncrewed Aerial Vehicle
USS	UAS Service Supplier
UTM	Uncrewed Aerial System Traffic Management
UUAA	USS UAV AA
UUID	Universal Unique Identifier

---

## 4 Overview

### 4.1 Introduction

Within the 5GC, the NEF (UAS-NF) offers services to the AMF, SMF, and PCF via the Nnef service based interface, and the NEF (UAS-NF) offers services to the SMF+PGW-C via the Nnef service based interface for UUAA-SM and C2 procedure supported in EPS (see 3GPP TS 23.256 [6]).

Figure 4.1-1 provides the reference model (in service based interface representation and in reference point representation), with focus on the NEF (UAS-NF) and the scope of the present specification.

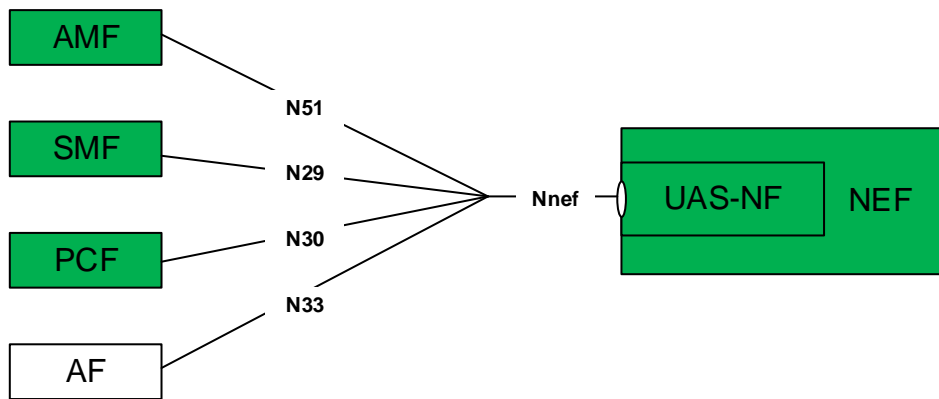

Figure 4.1-1: Reference model – NEF (UAS-NF)

The functionalities supported by the NEF (UAS-NF) are listed in clause 4.3.2 of 3GPP TS 23.256 [6].

## 5 Services offered by the NEF (UAS-NF)

### 5.1 Introduction

The table 5.1-1 shows the NEF (UAS-NF) Services and Service Operations:

Table 5.1-1 List of NEF (UAS-NF) Services

Service Name	Service Operations	Operation Semantics	Example Consumer(s)	Mapped Service Operation
Nnef_Authentication	Authenticate/Authorize	Request/Response	AMF, SMF, SMF+PGW-C	Nnef_Authentication_Authenticate/Authorize
	Notification	Subscribe/Notify	AMF, SMF, SMF+PGW-C	Nnef_Authentication_Notification
Nnef_UAVFlightAssistance	See 3GPP TS 29.522 [17].			
Nnef_RetrieveInfoUAVFlight	See 3GPP TS 29.522 [17].			

Table 5.1-2 summarizes the corresponding APIs defined in this specification.

Table 5.1-2: API Descriptions

Service Name	Clause	Description	OpenAPI Specification File	apiName	Annex
Nnef_Authentication	6.1	NEF (UAS-NF) authentication service	TS29256_Nnef_Authentication.yaml	nnef-authentication	A.2

### 5.2 Nnef\_Authentication Service

#### 5.2.1 Service Description

The service allows communication of authentication and authorization messages between AMF/SMF and external AF (USS) through NEF (UAS-NF). An NF as service consumer (e.g. AMF, SMF, SMF+PGW-C) can request authentication and authorization or subscribe to receive notifications from NEF (UAS-NF) related to reauthentication, authorization data update or authorization revoke of the UAV.

## 5.2.2 Service Operations

### 5.2.2.1 Introduction

The Nnef\_Authentication service supports following service operations:

- AuthenticateAuthorize
- Notification

### 5.2.2.2 AuthenticateAuthorize Service Operation

#### 5.2.2.2.1 General

The AuthenticateAuthorize service operation is used during the following procedure:

- UUA-MM and UUA-SM procedures (see 3GPP TS 23.256 [6], clause 5.2.2 and clause 5.2.3, respectively)
- C2 authorization (see 3GPP TS 23.256 [6], clause 5.2.5 and clause 5.4)

The AuthenticateAuthorize service operation is invoked by an NF Service Consumer (e.g. an AMF, SMF, SMF+PGW-C) towards the NEF (UAS-NF), when UUA-MM is done at 5GS registration, UUA-SM is done at PDU session establishment, or for Authorization for C2 in 5GS or EPS.

The NF Service Consumer (e.g. the AMF or the SMF or the SMF+PGW-C) shall send the authentication message to NEF (UAS-NF) by sending the HTTP POST request towards the UAV Authentications resource as shown in Figure 5.2.2.2.1-1.

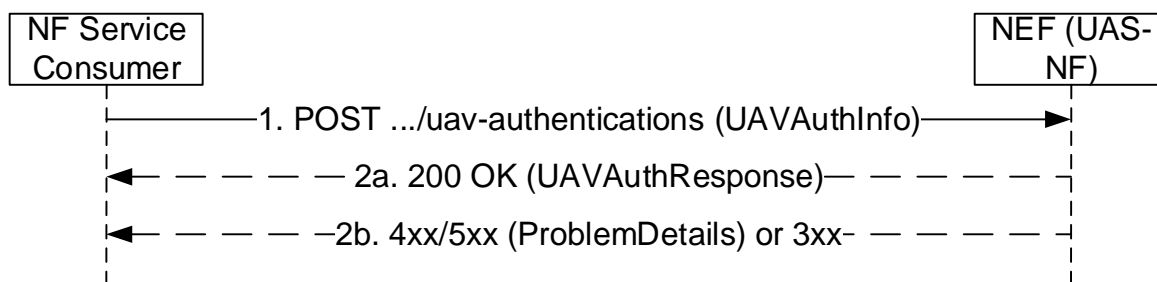

**Figure 5.2.2.2.1-1: AuthenticateAuthorize Service Operation**

1. The NF Service Consumer shall send a POST request to the resource representing the UAV Authentications resource of the NEF (UAS-NF) with a "UAVAuthInfo" object in the request body, including:

- gpsi IE set to GPSI (in the format of External Identifier) of the UAV;
- serviceLevelId IE set to Service Level Device Identity;
- authMsg IE contains the service-level AA message
- . This IE is deprecated; the "authContainer" IE should be used instead.
- "authContainer" IE that contains one or more authentication message(s) in the AA container provided by the UE (see 3GPP TS 23.256 [6]). This IE deprecates the "authMsg" IE.
- authNotificationURI IE provides the notification URI to receive notifications related to authentication;
- authServerAddress IE provides the Authorization Server Address, e.g. Authorization Server FQDN. This IE is not included for intermediate round-trip authentication messages;
- nfType IE carries the NF type of the NF service consumer (e.g. AMF or SMF or SMF+PGW-C); and
- userLocInfo IE provides the user location information (e.g. cell Id).

If the NF Service Consumer is SMF or SMF+PGW-C, the "UAVAuthInfo" also may include:

- ipAddr IE carries the IP Address associated with the PDU session;
- pei IE carries the PEI;

If the NF Service Consumer is SMF or SMF+PGW-C, for UUAA-MM and UUAA-SM procedures the "UAVAuthInfo" also may include:

- dnn IE carries the DNN which can be used by NEF (UAS-NF) later on to create a subscription at SMF; and
- sNssai IE carries the S-NSSAI which can be used by NEF (UAS-NF) later on to create a subscription at SMF.

2a. On success, the NEF (UAS-NF) shall store the result and return "200 OK".

For intermediate round-trip messages, the content (i.e. UAVAuthResponse) shall contain the GPSI of the UAV and Service Level Device Identity. The content optionally includes "authContainer", see 3GPP TS 23.256 [6] for further details.

For the final NEF (UAS-NF) to NF service consumer message, the content (i.e. UAVAuthResponse) shall contain the GPSI of the UAV, notifyCorrId attribute and "authResult" attribute. If the UAV is authenticated successfully, the NEF (UAS-NF) shall set the "authResult" attribute to "AUTH\_SUCCESS". "authMsg" and "authResult" attributes are deprecated; the attribute "authContainer" should be used instead. The content shall contain the authorized Service Level Device Identity and "authContainer" content delivering the AA result, configuration information to the UAV. The AMF forwards the message transparently to UE over NAS MM.

2b. On failure or redirection, one of the HTTP status codes listed in Table 6.1.7.3-1 shall be returned. For a 4xx/5xx response, the message body containing a ProblemDetails structure with the "cause" attribute set to one of the application errors listed in Table 6.1.7.3-1.

If the NEF (UAS-NF) cannot successfully fulfil the received HTTP POST request due to an internal error or an error in the HTTP POST request, the NEF (UAS-NF) shall send the HTTP error response as specified in clause 6.1.7.

If the UAV authentication is failed, the NEF (UAS-NF) shall reject the request with an HTTP "403 Forbidden" response message including the "cause" attribute of the ProblemDetails data structure set to "AUTHENTICATION\_FAILURE". NEF (UAS-NF) shall also include an indication of uasResourceRelease received from the USS to indicate if the PDU sessions associated with the "DNN(s) subject to aerial services" can be released or not, during re-authentication failure, when the service operation is used during Re-authentication procedure.

In above steps, while there is no expected response from the USS in the case of time out, the NEF(UAS-NF) shall return HTTP status code "504 Gateway Timeout", with the message body containing a ProblemDetails structure with the "cause" attribute set to "PEER\_NOT\_RESPONDING".

### 5.2.2.3 AuthNotify Service Operation

#### 5.2.2.3.1 General

The AuthNotify service operation is used during the following procedure:

- USS Initiated reauthentication (see 3GPP TS 23.256 [6], clause 5.2.4)
- USS Initiated update authorization data or revoke authorization of the UAV

The AuthNotify service operation is invoked by the NEF (UAS-NF) to inform a NF Service Consumer (e.g. AMF, SMF, SMF+PGW-C), when USS triggers reauthentication, update authorization data or revoke authorization of the UAV. NEF (UAS-NF) shall determine the NF service consumer based on the previously stored UUAA context during the successful UUAA procedure as defined in clause 5.2.2.2.

The NEF (UAS-NF) shall send the AuthNotify request by sending the HTTP POST method towards the Notification URI as shown in Figure 5.2.2.3.1-1.

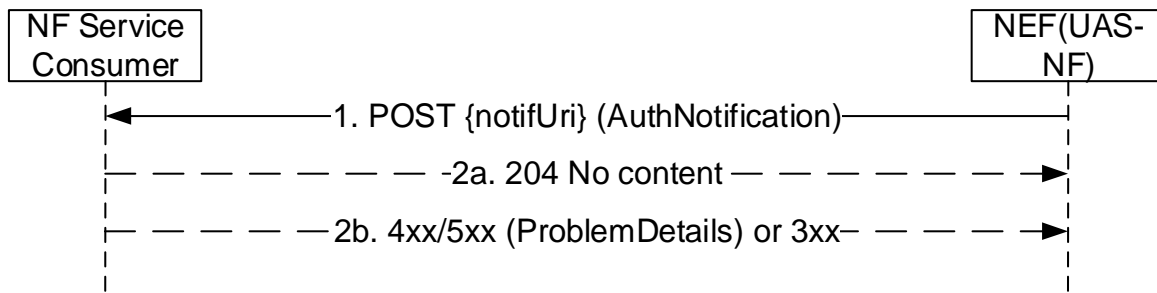

**Figure 5.2.2.3.1-1: AuthNotify Service Operation**

1. The NEF (UAS-NF) shall send a POST request towards the Notification URI received in the Authenticate service operation request (See clause 5.2.2.2.1). If the AMF for UUAA-MM has changed, the NEF (UAS-NF) should discover the Notification URI of the new AMF via NRF (in the default notification subscription with the "UUAA\_MM\_AUTH\_NOTIFICATION" notification type). The NEF (UAS-NF) shall be able to determine the NF type of the NF service consumer by nfType IE received in the Authenticate service operation request. The request body shall contain an "AuthNotification" object containing the reauthentication information or update authorization information or revoke authorization indication.

When the procedure is used for reauthentication or reauthorization/update authorization information, the AuthNotification object includes:

- the gpsi IE set to the GPSI (in the format of External Identifier) of the given UAV required to be reauthenticated;
- serviceLevelId IE set to the Service Level Device Identity of the UAV;
- authMsg IE contains the service-level AA message. This IE is deprecated; the "authContainer" IE should be used instead.
- "authContainer" IE that contains AA related data provided by the UE (see 3GPP TS 23.256 [6]). This IE deprecates the "authMsg" IE.
- notifType IE set to REAUTH used for reauthentication and/or notifType IE set to UPDATEAUTH used for update authorization data; and
- notifyCorrId IE set to the notification correlation ID;

When the procedure is used for authorization revocation, the AuthNotification object includes:

- the gpsi IE set to the GPSI (in the format of External Identifier) of the given UAV;
- serviceLevelId IE set to the Service Level Device Identity of the UAV;
- notifType IE set to REVOKE; and
- notifyCorrId IE set to the notification correlation ID;

2a. On success, "204 No content" shall be returned without response body. If the NF Service consumer remove the successful UUAA result during UUAA Revocation procedure, the NEF (UAS-NF) shall remove the UUAA context (see clause 5.2.7 of 3GPP TS 23.256 [6]).

2b. On failure or redirection, one of the HTTP status code listed in Table 6.1.5.2.3.1-3 shall be returned. For a 4xx/5xx response, the response body should contain a "ProblemDetails" object.

If the NF service consumer cannot successfully fulfil the received HTTP POST request due to an internal error or an error in the HTTP POST request, the NF service consumer shall send an HTTP error response as specified in clause 6.1.7.

---

## 6 API Definitions

### 6.1 Nnef\_Authentication Service API

#### 6.1.1 Introduction

The Nnef\_Authentication shall use the Nnef\_Authentication API.

The API URI of the Nnef\_Authentication API shall be:

**{apiRoot}/<apiName>/<apiVersion>**

The request URIs used in HTTP requests from the NF service consumer towards the NF service producer shall have the Resource URI structure defined in clause 4.4.1 of 3GPP TS 29.501 [5], i.e.:

**{apiRoot}/<apiName>/<apiVersion>/<apiSpecificResourceUriPart>**

with the following components:

- The {apiRoot} shall be set as described in 3GPP TS 29.501 [5].
- The <apiName> shall be "nnef-authentication".
- The <apiVersion> shall be "v1".
- The <apiSpecificResourceUriPart> shall be set as described in clause 6.1.3.

#### 6.1.2 Usage of HTTP

##### 6.1.2.1 General

HTTP/2, IETF RFC 9113 [8], shall be used as specified in clause 5 of 3GPP TS 29.500 [4].

HTTP/2 shall be transported as specified in clause 5.3 of 3GPP TS 29.500 [4].

The OpenAPI [9] specification of HTTP messages and content bodies for the Nnef\_Authentication API is contained in Annex A.

##### 6.1.2.2 HTTP standard headers

###### 6.1.2.2.1 General

See clause 5.2.2 of 3GPP TS 29.500 [4] for the usage of HTTP standard headers.

###### 6.1.2.2.2 Content type

JSON, IETF RFC 8259 [10], shall be used as content type of the HTTP bodies specified in the present specification as specified in clause 5.4 of 3GPP TS 29.500 [4]. The use of the JSON format shall be signalled by the content type "application/json".

"Problem Details" JSON object shall be used to indicate additional details of the error in a HTTP response body and shall be signalled by the content type "application/problem+json", as defined in IETF RFC 9457 [11].

##### 6.1.2.3 HTTP custom headers

The mandatory HTTP custom header fields specified in clause 5.2.3.2 of 3GPP TS 29.500 [4] shall be applicable.

## 6.1.3 Resources

### 6.1.3.1 Overview

This clause describes the structure for the Resource URIs and the resources and methods used for the service.

Figure 6.1.3.1-1 depicts the resource URIs structure for the Nnef\_Authentication API.

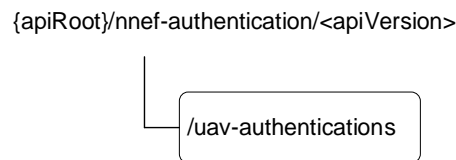

**Figure 6.1.3.1-1: Resource URI structure of the Nnef\_Authentication API**

Table 6.1.3.1-1 provides an overview of the resources and applicable HTTP methods.

**Table 6.1.3.1-1: Resources and methods overview**

Resource name	Resource URI	HTTP method or custom operation	Description
uav-authentications	/uav-authentications	POST	A UAV authentication

### 6.1.3.2 Resource: uav-authentications

The resource represents UAV Authentications to be done with the NEF (UAS-NF).

#### 6.1.3.2.1 Description

#### 6.1.3.2.2 Resource Definition

Resource URI: **{apiRoot}/nnef-authentication/<apiVersion>/uav-authentications**

This resource shall support the resource URI variables defined in table 6.1.3.2.2-1.

**Table 6.1.3.2.2-1: Resource URI variables for this resource**

Name	Data type	Definition
apiRoot	string	See clause 6.1.1

### 6.1.3.2.3 Resource Standard Methods

#### 6.1.3.2.3.1 POST

This method performs UAV authentication.

This method shall support the URI query parameters specified in table 6.1.3.2.3.1-1.

**Table 6.1.3.2.3.1-1: URI query parameters supported by the POST method on this resource**

Name	Data type	P	Cardinality	Description	Applicability
n/a					

This method shall support the request data structures specified in table 6.1.3.2.3.1-2 and the response data structures and response codes specified in table 6.1.3.2.3.1-3.

**Table 6.1.3.2.3.1-2: Data structures supported by the POST Request Body on this resource**

Data type	P	Cardinality	Description
UAVAuthInfo	M	1	Represents the data to be used for UAV authentication

**Table 6.1.3.2.3.1-3: Data structures supported by the POST Response Body on this resource**

Data type	P	Cardinality	Response codes	Description
UAVAuthResponse	M	1	200 OK	Successful request of UAV authentication and authorization. If C2 authorization request is sent during UUAA-SM, the final response indicates that at least UUAA has succeeded.
RedirectResponse	O	0..1	307 Temporary Redirect	Temporary redirection. (NOTE 2)
RedirectResponse	O	0..1	308 Permanent Redirect	Permanent redirection. (NOTE 2)
UAVAuthFailure	O	0..1	403 Forbidden	This represents that the UAV authentication is failed, the "cause" attribute of the ProblemDetails data structure set to one of the following application errors: - AUTHENTICATION_FAILURE - SERVICE_NOT_ALLOWED See table 6.1.7.3-1 for the description of these errors.
ProblemDetails	O	0..1	504 Gateway Timeout	The "cause" attribute may be used to indicate the following application error: - PEER_NOT_RESPONDING  See table 6.1.7.3-1 for the description of the error.
NOTE 1: The mandatory HTTP error status code for the POST method listed in Table 5.2.7.1-1 of 3GPP TS 29.500 [4] also apply.				
NOTE 2: RedirectResponse may be inserted by an SCP, see clause 6.10.9.1 of 3GPP TS 29.500 [4].				

**Table 6.1.3.2.3.1-4: Headers supported by the 307 Response Code on this resource**

Name	Data type	P	Cardinality	Description
Location	string	M	1	An alternative URI of the resource located on an alternative service instance within the same NEF (UAS-NF) or NEF (UAS-NF) (service) set. For the case, when a request is redirected to the same target resource via a different SCP, see clause 6.10.9.1 in 3GPP TS 29.500 [4].
3gpp-Sbi-Target-Nf-Id	string	O	0..1	Identifier of the target NF (service) instance ID towards which the request is redirected

**Table 6.1.3.2.3.1-5: Headers supported by the 308 Response Code on this resource**

Name	Data type	P	Cardinality	Description
Location	string	M	1	An alternative URI of the resource located on an alternative service instance within the same NEF (UAS-NF) or UAS-NF/NEF (service) set. For the case, when a request is redirected to the same target resource via a different SCP, see clause 6.10.9.1 in 3GPP TS 29.500 [4].
3gpp-Sbi-Target-Nf-Id	string	O	0..1	Identifier of the target NF (service) instance ID towards which the request is redirected

#### 6.1.3.2.4 Resource Custom Operations

None

### 6.1.5 Notifications

#### 6.1.5.1 General

This clause specifies the notifications provided by the Nnef\_Authentication service.

Notifications shall comply to clause 6.2 of 3GPP TS 29.500 [4] and clause 4.6.2.3 of 3GPP TS 29.501 [5].

#### 6.1.5.2 Authentication Notification

##### 6.1.5.2.1 Description

The NF Service Consumer (e.g. the AMF or SMF or SMF+PGW-C) provides the Notification URI for getting notified about reauthentication requested by the USS. The NEF (UAS-NF) shall notify the NF Service Consumer when reauthentication is requested by the USS.

##### 6.1.5.2.2 Target URI

The Notification URI "{notifUri}" shall be used with the callback URI variables defined in table 6.1.5.2.2-1.

**Table 6.1.5.2.2-1: Callback URI variables**

Name	Definition
n/a	n/a

#### 6.1.5.2.3 Standard Methods

##### 6.1.5.2.3.1 POST

This method shall support the request data structures specified in table 6.1.5.2.3.1-1 and the response data structures and response codes specified in table 6.1.5.2.3.1-2.

**Table 6.1.5.2.3.1-1: Data structures supported by the POST Request Body**

Data type	P	Cardinality	Description
AuthNotification	M	1	Contains the reauthentication information.

**Table 6.1.5.2.3.1-2: Data structures supported by the POST Response Body**

Data type	P	Cardinality	Response codes	Description
n/a			204 No Content	Successful notification of reauthentication
RedirectResponse	O	0..1	307 Temporary Redirect	Temporary redirection. (NOTE 2)
RedirectResponse	O	0..1	308 Permanent Redirect	Permanent redirection. (NOTE 2)
NOTE 1: The mandatory HTTP error status codes for the POST method listed in Table 5.2.7.1-1 of 3GPP TS 29.500 [4] also apply, with response body containing an object of ProblemDetails data type (see clause 5.2.7 of 3GPP TS 29.500 [4]).				
NOTE 2: RedirectResponse may be inserted by an SCP, see clause 6.10.9.1 of 3GPP TS 29.500 [4].				

**Table 6.1.5.2.3.1-4: Headers supported by the 307 Response Code on this resource**

Name	Data type	P	Cardinality	Description
Location	string	M	1	A URI pointing to the endpoint of NF service consumer to which the notification should be sent. For the case, when a request is redirected to the same target resource via a different SCP, see clause 6.10.9.1 in 3GPP TS 29.500 [4].
3gpp-Sbi-Target-Nf-Id	string	O	0..1	Identifier of the target NF (service) instance ID towards which the notification is redirected.

**Table 6.1.5.2.3.1-5: Headers supported by the 308 Response Code on this resource**

Name	Data type	P	Cardinality	Description
Location	string	M	1	A URI pointing to the endpoint of NF service consumer to which the notification should be sent. For the case, when a request is redirected to the same target resource via a different SCP, see clause 6.10.9.1 in 3GPP TS 29.500 [4].
3gpp-Sbi-Target-Nf-Id	string	O	0..1	Identifier of the target NF (service) instance ID towards which the notification is redirected.

## 6.1.6 Data Model

### 6.1.6.1 General

This clause specifies the application data model supported by the API.

Table 6.1.6.1-1 specifies the data types defined for the Nnef\_Authentication service based interface protocol.

**Table 6.1.6.1-1: Nnef\_Authentication specific Data Types**

Data type	Clause defined	Description	Applicability
UAVAuthInfo	6.1.6.2.2	Information within Authenticate Request	
AuthNotification	6.1.6.2.3	Information within notification	
UAVAuthResponse	6.1.6.2.4	Information within Authenticate Response	
UAVAuthFailure	6.1.6.2.5	Information within Authenticate Response	
AuthResult	6.1.6.3.3	Enumeration indicating authentication result	
NotifType	6.1.6.3.4	Enumeration Notification type	
AuthContainer	6.1.6.2.6	Carries the AA related data	

Table 6.1.6.1-2 specifies data types re-used by the Nnef\_Authentication service based interface protocol from other specifications, including a reference to their respective specifications and when needed, a short description of their use within the Nnef\_Authentication service based interface.

**Table 6.1.6.1-2: Nnef\_Authentication re-used Data Types**

<b>Data type</b>	<b>Reference</b>	<b>Comments</b>	<b>Applicability</b>
IpAddr	3GPP TS 29.571 [15]	IP address	
Pei	3GPP TS 29.571 [15]	Permanent Equipment Identifier	
Uri	3GPP TS 29.571 [15]	Uri	
Gpsi	3GPP TS 29.571 [15]	GPSI	
ExtSnssai	3GPP TS 29.571 [15]	Ext Snssai	
Dnn	3GPP TS 29.571 [15]	DNN information	
UserLocation	3GPP TS 29.571 [15]	User location	
RedirectResponse	3GPP TS 29.571 [15]	Contains redirection related information	
NFType	3GPP TS 29.510 [14]	NF Type	
RefToBinaryData	3GPP TS 29.571 [15]	authMsg data, AA message payload data	
Bytes	3GPP TS 29.571 [15]	Binary data encoded as a base64 character string	
Ambr	3GPP TS 29.571 [15]	AMBR	

## 6.1.6.2 Structured data types

### 6.1.6.2.1 Introduction

This clause defines the structures to be used in resource representations.

6.1.6.2.2 Type: UAVAuthInfo

**Table 6.1.6.2.2-1: Definition of type UAVAuthInfo**

Attribute name	Data type	P	Cardinality	Description	Applicability
gpsi	Gpsi	M	1	GPSI of the UAV	
serviceLevelId	string	M	1	Service Level Device Identity of the UAV	
ipAddr	IpAddr	O	0..1	This IE may be present if the NF Service Consumer is the SMF or SMF+PGW-C.  When present, this IE indicates the IP address associated with the PDU session.	
authMsg	RefToBinaryData	O	0..1	Contains the service-level AA message. This attribute is deprecated; the attribute "authContainer" should be used instead.	
authContainer	array(AuthContainer)	O	1..N	Contains the AA related data without the "authResult" attribute. This attribute deprecates "authMsg" attribute.	
pei	Pei	O	0..1	This IE may be present if the NF Service Consumer is the SMF or SMF+PGW-C.  When present, PEI associated with the UAV.	
authServerAddress	string	O	0..1	Provides the Authorization Server Address, e.g. Authorization Server FQDN.	
authNotificationURI	Uri	C	0..1	This IE shall be present in the initial authentication message.  It carries the notification URI to receive authentication related notifications	
dnn	Dnn	C	0..1	This IE shall be present if the NF Service Consumer is the SMF or SMF+PGW-C.  When present, this IE indicates DNN associated with the PDU session.	
sNssai	ExtSnsai	C	0..1	This IE shall be present if the NF Service Consumer is the SMF.  When present, this IE indicates the S-NSSAI associated with the PDU session.	
ueLocInfo	UserLocation	O	0..1	This IE shall contain the UE location information if it is available.	
nfType	NFType	M	1	NFType of the NF service consumer. Possible NFType values supported in this release of the specification are - AMF - SMF	

## 6.1.6.2.3 Type: AuthNotification

Table 6.1.6.2.3-1: Definition of type AuthNotification

Attribute name	Data type	P	Cardinality	Description	Applicability
gpsi	Gpsi	M	1	GPSI of the UAV	
serviceLevelId	string	M	1	Service Level Device Identity of the UAV	
authMsg	RefToBinaryData	C	0..1	Contains the service-level AA message. This IE may be present if the notifType is set to "UPDATEAUTH". This attribute is deprecated; the attribute "authContainer" should be used instead.	
authContainer	array(AuthContainer)	C	1..N	Contains the AA related data, including optionally the "authResult" attribute. This IE shall be present if the notifType is set to "UPDATEAUTH". This attribute deprecates "authMsg" attribute.	
notifType	NotifType	M	1	This IE shall contain the notification type.	
notifyCorrId	string	M	1	This IE shall contain the Notification Correlation Id.	

## 6.1.6.2.4 Type: UAVAuthResponse

Table 6.1.6.2.4-1: Definition of type UAVAuthResponse

Attribute name	Data type	P	Cardinality	Description	Applicability
gpsi	Gpsi	M	1	GPSI of the UAV	
authResult	AuthResult	C	0..1	This IE shall be present for the final NEF (UAS-NF) to NF service consumer message.  Conveys the UAV authentication result. This attribute is deprecated; the attribute "authContainer" should be used instead.	
authMsg	RefToBinaryData	O	0..1	Contains the service-level AA message. This attribute is deprecated; the attribute "authContainer" should be used instead.	
authContainer	array(AuthContainer)	C	1..N	Contains the AA related data, including the "authResult" attribute in the final AA response. This attribute shall be present for the final AA response message. This attribute deprecates "authMsg" attribute.	
serviceLevelId	string	O	0..1	This IE contains the authorized Service Level Device Identity	
notifyCorrId	string	O	0..1	When present, this IE shall contain the Notification Correlation Id.	
authSessAmbr	Ambr	O	0..1	This attribute contains DN Authorized Session-AMBR.	
authProfIndex	string	O	0..1	This attribute contains DN authorization profile index.	

## 6.1.6.2.5 Type: UAVAuthFailure

Table 6.1.6.2.5-1: Definition of type UAVAuthFailure

Attribute name	Data type	P	Cardinality	Description	Applicability
error	ProblemDetails	M	1	Represents the application error information. The application level error cause shall be encoded in the "cause" attribute.	
uasResourceRelease	boolean	C	0..1	<p>This IE shall be present and used to indicate if the PDU sessions associated with the "DNN(s) subject to aerial services" can be released or not, during re-authentication failure.</p> <p>It shall be included if the "cause" attribute of the ProblemDetails data structure set to "AUTHENTICATION_FAILURE".</p> <p>When present, it shall be set as follows:</p> <ul style="list-style-type: none"> <li>- true: the PDU sessions associated with the "DNN(s) subject to aerial services" release is requested;</li> <li>- false (default): the PDU sessions associated with the "DNN(s) subject to aerial services" release is not requested.</li> </ul>	

## 6.1.6.2.6 Type: AuthContainer

Table 6.1.6.2.6-1: Definition of type AuthContainer

Attribute name	Data type	P	Cardinality	Description	Applicability
authMsgType	Bytes	O	0..1	This IE, when present, carries the Service-level-AA payload type specified in clause 9.11.2.15 of 3GPP TS 24.501 [16].	
authMsgPayload	RefToBinaryData	O	0..1	AA message payload data.	
authResult	AuthResult	C	0..1	Shall be present for the final AA response conveying the AA result.	

## 6.1.6.3 Simple data types and enumerations

## 6.1.6.3.1 Introduction

This clause defines simple data types and enumerations that can be referenced from data structures defined in the previous clauses.

### 6.1.6.3.2 Simple data types

The simple data types defined in table 6.1.6.3.2-1 shall be supported.

**Table 6.1.6.3.2-1: Simple data types**

Type Name	Type Definition	Description	Applicability

### 6.1.6.3.3 Enumeration: AuthResult

The enumeration AuthResult represents the result of authentication and/or authorization. It shall comply with the provisions defined in table 6.1.5.3.3-1.

**Table 6.1.6.3.3-1: Enumeration AuthResult**

Enumeration value	Description	Applicability
"AUTH_SUCCESS"	The UAV authentication or C2 Authorization has succeeded.	
"AUTH_FAIL"	The UAV authentication or C2 Authorization has failed.	

### 6.1.6.3.4 Enumeration: NotifType

The enumeration NotifType represents the type of notification. It shall comply with the provisions defined in table 6.1.6.3.4-1.

**Table 6.1.6.3.4-1: Enumeration NotifType**

Enumeration value	Description	Applicability
"REAUTH"	The UAV needs to be reauthenticated.	
"UPDATEAUTH"	Authorization data needs to be updated to UAV.	
"REVOKE"	Revoke UAV authentication and authorization	

## 6.1.7 Error Handling

### 6.1.7.1 General

For the Nnef\_Authentication API, HTTP error responses shall be supported as specified in clause 4.8 of 3GPP TS 29.501 [5]. Protocol errors and application errors specified in table 5.2.7.2-1 of 3GPP TS 29.500 [4] shall be supported for an HTTP method if the corresponding HTTP status codes are specified as mandatory for that HTTP method in table 5.2.7.1-1 of 3GPP TS 29.500 [4].

In addition, the requirements in the following clauses are applicable for the Nnef\_Authentication API.

### 6.1.7.2 Protocol Errors

No specific procedures for the Nnef\_Authentication service are specified.

### 6.1.7.3 Application Errors

The application errors defined for the Nnef\_Authentication service are listed in Table 6.1.7.3-1.

**Table 6.1.7.3-1: Application errors**

Application Error	HTTP status code	Description
AUTHENTICATION_FAILURE	403 Forbidden	The UAV authentication is failed
SERVICE_NOT_ALLOWED	403 Forbidden	UAS services not allowed
PEER_NOT_RESPONDING	504 Gateway Timeout	No response is received from the remote peer (i.e. USS) when time out.

## 6.1.8 Feature negotiation

The optional features in table 6.1.8-1 are defined for the Nnef\_Authentication API. They shall be negotiated using the extensibility mechanism defined in clause 6.6 of 3GPP TS 29.500 [4].

**Table 6.1.8-1: Supported Features**

Feature number	Feature Name	Description

## 6.1.9 Security

As indicated in 3GPP TS 33.501 [12] and 3GPP TS 29.500 [4], the access to the Nnef\_Authentication API may be authorized by means of the OAuth2 protocol (see IETF RFC 6749 [13]), based on local configuration, using the "Client Credentials" authorization grant, where the NRF (see 3GPP TS 29.510 [14]) plays the role of the authorization server.

If OAuth2 is used, an NF Service Consumer, prior to consuming services offered by the Nnef\_Authentication API, shall obtain a "token" from the authorization server, by invoking the Access Token Request service, as described in 3GPP TS 29.510 [14], clause 5.4.2.2.

**NOTE:** When multiple NRFs are deployed in a network, the NRF used as authorization server is the same NRF that the NF Service Consumer used for discovering the Nnef\_Authentication service.

The Nnef\_Authentication API defines a single scope "nnef-authentication" for the entire service, and it does not define any additional scopes at resource or operation level.

### 6.1.10 HTTP redirection

An HTTP request may be redirected to a different Nnef\_Authentication service instance when using direct or indirect communications (see 3GPP TS 29.500 [4]).

An SCP that reselects a different NEF (UAS-NF) producer instance will return the NF Instance ID of the new NEF (UAS-NF) producer instance in the 3gpp-Sbi-Producer-Id header, as specified in clause 6.10.3.4 of 3GPP TS 29.500 [4].

If an NEF (UAS-NF) redirects a service request to a different NEF (UAS-NF) using an 307 Temporary Redirect or 308 Permanent Redirect status code, the identity of the new NEF (UAS-NF) towards which the service request is redirected shall be indicated in the 3gpp-Sbi-Target-Nf-Id header of the 307 Temporary Redirect or 308 Permanent Redirect response as specified in clause 6.10.9.1 of 3GPP TS 29.500 [4].

# Annex A (normative): OpenAPI specification

## A.1 General

This Annex specifies the formal definition of the API(s) defined in the present specification. It consists of OpenAPI 3.0.0 specifications in YAML format, following guidelines in 3GPP TS 29.501 [5].

This Annex takes precedence when being discrepant to other parts of the specification with respect to the encoding of information elements and methods within the API(s).

NOTE 1: The semantics and procedures, as well as conditions, e.g. for the applicability and allowed combinations of attributes or values, not expressed in the OpenAPI definitions but defined in other parts of the specification also apply.

Informative copies of the OpenAPI specification files contained in this 3GPP Technical Specification are available on a Git-based repository that uses the GitLab software version control system (see clause 5.3.1 of 3GPP TS 29.501 [5] and clause 5B of 3GPP TR 21.900 [7]).

## A.2 Nnef\_Authentication API

```

openapi: 3.0.0

info:
  title: Nnef_Authentication
  version: '1.2.0'
  description: |
    NEF Auth Service.
    © 2025, 3GPP Organizational Partners (ARIB, ATIS, CCSA, ETSI, TSDSI, TTA, TTC).
    All rights reserved.

externalDocs:
  description: >
    3GPP TS 29.256 V19.4.0; 5G System;Uncrewed Aerial Systems Network Function (UAS-NF);
    Aerial Management Services; Stage 3
  url: https://www.3gpp.org/ftp/Specs/archive/29_series/29.256/

servers:
  - url: '{apiRoot}/nnef-authentication/v1'
    variables:
      apiRoot:
        default: https://example.com
        description: apiRoot as defined in clause 4.4 of 3GPP TS 29.501

security:
  - {}
  - oAuth2ClientCredentials:
    - nnef-authentication

paths:
  /uav-authentications:
    post:
      summary: UAV authentication
      tags:
        - UAV authentication
      requestBody:
        description: UAV authentication
        required: true
        content:
          application/json:
            schema:
              $ref: '#/components/schemas/UAVAuthInfo'
      responses:
        '200':
          description: UAV Auth response or message exchange
          content:
            application/json:

```

```

    schema:
      $ref: '#/components/schemas/UAVAuthResponse'
  '307':
    $ref: 'TS29571_CommonData.yaml#/components/responses/307'
  '308':
    $ref: 'TS29571_CommonData.yaml#/components/responses/308'
  '400':
    $ref: 'TS29571_CommonData.yaml#/components/responses/400'
  '403':
    description: UAV authentication failure
    content:
      application/json:
        schema:
          $ref: '#/components/schemas/UAVAuthFailure'
  '504':
    $ref: 'TS29571_CommonData.yaml#/components/responses/504'
default:
  $ref: 'TS29571_CommonData.yaml#/components/responses/default'
callbacks:
  authNotification:
    '{$request.body#/authNotificationURI}':
      post:
        requestBody:
          required: true
          content:
            application/json:
              schema:
                $ref: '#/components/schemas/AuthNotification'
        responses:
          '204':
            description: Successful Notification response
          '307':
            $ref: 'TS29571_CommonData.yaml#/components/responses/307'
          '308':
            $ref: 'TS29571_CommonData.yaml#/components/responses/308'
          '400':
            $ref: 'TS29571_CommonData.yaml#/components/responses/400'
          default:
            $ref: 'TS29571_CommonData.yaml#/components/responses/default'

components:
  securitySchemes:
    oAuth2ClientCredentials:
      type: oauth2
      flows:
        clientCredentials:
          tokenUrl: '{nrfApiRoot}/oauth2/token'
          scopes:
            nnef-authentication: Access to the Nnef_authentication API

schemas:
#
# STRUCTURED DATA TYPES
#
  UAVAuthInfo:
    description: UAV auth data
    type: object
    required:
      - gpsi
      - serviceLevelId
      - nfType
    properties:
      gpsi:
        $ref: 'TS29571_CommonData.yaml#/components/schemas/Gpsi'
      serviceLevelId:
        type: string
      authNotificationURI:
        $ref: 'TS29571_CommonData.yaml#/components/schemas/Uri'
      ipAddr:
        $ref: 'TS29571_CommonData.yaml#/components/schemas/IpAddr'
      pei:
        $ref: 'TS29571_CommonData.yaml#/components/schemas/Pei'
      authServerAddress:
        type: string

```

```

authMsg:
  allOf:
    - $ref: 'TS29571_CommonData.yaml#/components/schemas/RefToBinaryData'
    deprecated: true
authContainer:
  type: array
  items:
    $ref: '#/components/schemas/AuthContainer'
  minItems: 1
ueLocInfo:
  $ref: 'TS29571_CommonData.yaml#/components/schemas/UserLocation'
dnn:
  $ref: 'TS29571_CommonData.yaml#/components/schemas/Dnn'
sNssai:
  $ref: 'TS29571_CommonData.yaml#/components/schemas/ExtSnsai'
nfType:
  $ref: 'TS29510_Nnrf_NFManagement.yaml#/components/schemas/NFType'

UVAAuthResponse:
description: UAV auth response data
type: object
required:
  - gpsi
properties:
  gpsi:
    $ref: 'TS29571_CommonData.yaml#/components/schemas/Gpsi'
  serviceLevelId:
    type: string
  authMsg:
    allOf:
      - $ref: 'TS29571_CommonData.yaml#/components/schemas/RefToBinaryData'
      deprecated: true
  authContainer:
    type: array
    items:
      $ref: '#/components/schemas/AuthContainer'
    minItems: 1
  authResult:
    allOf:
      - $ref: '#/components/schemas/AuthResult'
      deprecated: true
  notifyCorrId:
    type: string
  authSessAmbr:
    $ref: 'TS29571_CommonData.yaml#/components/schemas/Ambr'
  authProfIndex:
    type: string

AuthNotification:
description: UAV related notification
type: object
required:
  - gpsi
  - serviceLevelId
  - notifType
  - notifyCorrId
properties:
  gpsi:
    $ref: 'TS29571_CommonData.yaml#/components/schemas/Gpsi'
  serviceLevelId:
    type: string
  notifyCorrId:
    type: string
  authMsg:
    allOf:
      - $ref: 'TS29571_CommonData.yaml#/components/schemas/RefToBinaryData'
      deprecated: true
  authContainer:
    type: array
    items:
      $ref: '#/components/schemas/AuthContainer'
    minItems: 1
  notifType:
    $ref: '#/components/schemas/NotifType'

UVAAuthFailure:
description: UAV auth failure

```

```
type: object
required:
- error
properties:
  error:
    $ref: 'TS29571_CommonData.yaml#/components/schemas/ProblemDetails'
  uasResourceRelease:
    type: boolean
    default: false
```

```
AuthContainer:
  description: Authentication/Authorization data
  type: object
  properties:
    authMsgType:
      $ref: 'TS29571_CommonData.yaml#/components/schemas/Bytes'
    authMsgPayload:
      $ref: 'TS29571_CommonData.yaml#/components/schemas/RefToBinaryData'
    authResult:
      $ref: '#/components/schemas/AuthResult'
```

```
#
# SIMPLE DATA TYPES
#
```

```
#
# ENUMERATIONS
#
```

```
AuthResult:
  description: Enumeration representing the result of authentication and/or authorization.
  anyOf:
  - type: string
    enum:
    - AUTH_SUCCESS
    - AUTH_FAIL
  - type: string
NotifType:
  description: Enumeration representing the type of notification.
  anyOf:
  - type: string
    enum:
    - REAUTH
    - UPDATEAUTH
    - REVOKE
  - type: string
```

## Annex B (informative): Change history

Change history							
Date	Meeting	TDoc	CR	R ev	Cat	Subject/Comment	New version
2021-04	CT4#103-e	C4-212292				Initial TS skeleton.	0.0.0
2021-04	CT4#103-e	C4-212598				Added scope, introduction, references, and abbreviations.	0.1.0
2021-05	CT4#104-e	C4-213529				Aligned introduction terminology. Added, updated references.	0.2.0
2021-08	CT4#105-e	C4-214758				Aligned interfaces, added Nnef_Auth service.	0.3.0
2021-10	CT4#106-e	C4-215522				Several alignments with stage-2, clean-up, added OpenAPI for Nnef_Auth.	0.4.0
2021-11	CT4#107-e	C4-216474				Several further alignments with stage-2: aligned API and operation names, terminology. Further clean-up done.	0.5.0
2021-12	CT#94	CP-213160				V1.0.0 presented for information	1.0.0
2022-01	CT4#107bis-e	C4-220456				Several consistency issues addressed. Implemented pCRs C4-220121, C4-220122, C4-220285, C4-220291, C4-220292, C4-220293, and C4-220387	1.1.0
2022-02	CT4#108-e	C4-221594				Further consistency issues addressed. Implemented pCRs C4-221324, C4-221494, C4-221519, and C4-221340.	1.2.0
2022-03	CT#95e	CP-220109				TS presented for approval	2.0.0
2022-03	CT#95e					TS approved	17.0.0
2022-06	CT#96e	CP-221044	0001	1		Add Notification Correlation id	17.1.0
2022-06	CT#96e	CP-221044	0002	1		Indication of UAS service release	17.1.0
2022-06	CT#96e	CP-221044	0004			Removal of revoke cause	17.1.0
2022-06	CT#96e	CP-221028	0005			Remove the apiVersion placeholder from the resource URI variables table	17.1.0
2022-06	CT#96e	CP-221282	0007	1		29.256 Rel-17 API version and External doc update	17.1.0
2022-09	CT#97e	CP-222036	0009			Fix for formatting of OpenAPI description field	17.2.0
2022-09	CT#97e	CP-222058	0010			29.256 Rel-17 API version and External doc update	17.2.0
2022-12	CT#98e	CP-223056	0008	2		Corrections for Auth message type	17.3.0
2022-12	CT#98e	CP-223066	0011			29.256 Rel-17 API version and External doc update	17.3.0
2023-03	CT#99	CP-230082	0012	1		Rejecting PDN connection for C2 communication when UAS service is not allowed	17.4.0
2023-03	CT#99	CP-230068	0014			Miscellaneous corrections	18.0.0
2023-06	CT#100	CP-231027	0013	5	F	Location header and missing Redirection clause	18.1.0
2023-09	CT#101	CP-232047	0018	1	A	Authorization Notification Callbackfor UUAA-MM after AMF Change	18.2.0
2023-09	CT#101	CP-232046	0017	-	B	Clarification on Direct C2 authorization procedure	18.2.0
2023-12	CT#102	CP-233027	0020	-	F	HTTP RFCs obsoleted by IETF RFC 9113	18.3.0
2023-12	CT#102	CP-233030	0021	-	F	ProblemDetails RFC 7807 obsoleted by 9457	18.3.0
2024-06	CT#104	CP-241028	0022	1	F	Callbacks	18.4.0
2024-06	CT#104	CP-241058	0024	1	A	Correction on the policy parameters	18.4.0
2024-06	CT#104	CP-241052	0027		F	29.256 Rel-18 API version and External doc update	18.4.0
2024-12	CT#106	CP-243035	0029	2	F	Correct the notification URI	19.0.0
2024-12	CT#106	CP-243069	0030		F	29.256 0030 Rel19 API version and External doc update	19.0.0
2025-03	CT#107	CP-250041	0031	1	F	Clarifications on the scope	19.1.0
2025-06	CT#108	CP-251063	0032		F	Correction of the service description on Nnef_Authentication	19.2.0
2025-06	CT#108	CP-251079	0033		F	29.256 Rel-19 API version and External doc update	19.2.0
2025-09	CT#109	CP-252176	0034		F	29.256 Rel-19 API version and External doc update	19.3.0
2025-12	CT#110	CP-253167	0035		F	Rel-19 OpenAPI version and ExternalDocs Update CRs	19.4.0

---

## History

<b>Version</b>	<b>Date</b>	<b>Status</b>
V19.3.0	January 2026	Publication
V19.4.0	February 2026	Publication