

ETSI TS 129 578 V19.2.0 (2026-01)



TECHNICAL SPECIFICATION

5G;
5G System; Mobile Number Portability Services; Stage 3
(3GPP TS 29.578 version 19.2.0 Release 19)



Reference

RTS/TSGC-0429578vj20

Keywords

5G

ETSI

650 Route des Lucioles
F-06921 Sophia Antipolis Cedex - FRANCE

Tel.: +33 4 92 94 42 00 Fax: +33 4 93 65 47 16

Siret N° 348 623 562 00017 - APE 7112B
Association à but non lucratif enregistrée à la
Sous-Préfecture de Grasse (06) N° w061004871

Important notice

The present document can be downloaded from the
[ETSI Search & Browse Standards application](#).

The present document may be made available in electronic versions and/or in print. The content of any electronic and/or print versions of the present document shall not be modified without the prior written authorization of ETSI. In case of any existing or perceived difference in contents between such versions and/or in print, the prevailing version of an ETSI deliverable is the one made publicly available in PDF format on [ETSI deliver repository](#).

Users should be aware that the present document may be revised or have its status changed, this information is available in the [Milestones listing](#).

If you find errors in the present document, please send your comments to the relevant service listed under [Committee Support Staff](#).

If you find a security vulnerability in the present document, please report it through our [Coordinated Vulnerability Disclosure \(CVD\)](#) program.

Notice of disclaimer & limitation of liability

The information provided in the present deliverable is directed solely to professionals who have the appropriate degree of experience to understand and interpret its content in accordance with generally accepted engineering or other professional standard and applicable regulations.

No recommendation as to products and services or vendors is made or should be implied.

No representation or warranty is made that this deliverable is technically accurate or sufficient or conforms to any law and/or governmental rule and/or regulation and further, no representation or warranty is made of merchantability or fitness for any particular purpose or against infringement of intellectual property rights.

In no event shall ETSI be held liable for loss of profits or any other incidental or consequential damages.

Any software contained in this deliverable is provided "AS IS" with no warranties, express or implied, including but not limited to, the warranties of merchantability, fitness for a particular purpose and non-infringement of intellectual property rights and ETSI shall not be held liable in any event for any damages whatsoever (including, without limitation, damages for loss of profits, business interruption, loss of information, or any other pecuniary loss) arising out of or related to the use of or inability to use the software.

Copyright Notification

No part may be reproduced or utilized in any form or by any means, electronic or mechanical, including photocopying and microfilm except as authorized by written permission of ETSI.

The content of the PDF version shall not be modified without the written authorization of ETSI.

The copyright and the foregoing restriction extend to reproduction in all media.

© ETSI 2026.
All rights reserved.

Intellectual Property Rights

Essential patents

IPRs essential or potentially essential to normative deliverables may have been declared to ETSI. The declarations pertaining to these essential IPRs, if any, are publicly available for **ETSI members and non-members**, and can be found in ETSI SR 000 314: "*Intellectual Property Rights (IPRs); Essential, or potentially Essential, IPRs notified to ETSI in respect of ETSI standards*", which is available from the ETSI Secretariat. Latest updates are available on the [ETSI IPR online database](#).

Pursuant to the ETSI Directives including the ETSI IPR Policy, no investigation regarding the essentiality of IPRs, including IPR searches, has been carried out by ETSI. No guarantee can be given as to the existence of other IPRs not referenced in ETSI SR 000 314 (or the updates on the ETSI Web server) which are, or may be, or may become, essential to the present document.

Trademarks

The present document may include trademarks and/or tradenames which are asserted and/or registered by their owners. ETSI claims no ownership of these except for any which are indicated as being the property of ETSI, and conveys no right to use or reproduce any trademark and/or tradename. Mention of those trademarks in the present document does not constitute an endorsement by ETSI of products, services or organizations associated with those trademarks.

DECT™, **PLUGTESTS™**, **UMTS™** and the ETSI logo are trademarks of ETSI registered for the benefit of its Members. **3GPP™**, **LTE™** and **5G™** logo are trademarks of ETSI registered for the benefit of its Members and of the 3GPP Organizational Partners. **oneM2M™** logo is a trademark of ETSI registered for the benefit of its Members and of the oneM2M Partners. **GSM®** and the GSM logo are trademarks registered and owned by the GSM Association.

Legal Notice

This Technical Specification (TS) has been produced by ETSI 3rd Generation Partnership Project (3GPP).

The present document may refer to technical specifications or reports using their 3GPP identities. These shall be interpreted as being references to the corresponding ETSI deliverables.

The cross reference between 3GPP and ETSI identities can be found at [3GPP to ETSI numbering cross-referencing](#).

Modal verbs terminology

In the present document "**shall**", "**shall not**", "**should**", "**should not**", "**may**", "**need not**", "**will**", "**will not**", "**can**" and "**cannot**" are to be interpreted as described in clause 3.2 of the [ETSI Drafting Rules](#) (Verbal forms for the expression of provisions).

"**must**" and "**must not**" are **NOT** allowed in ETSI deliverables except when used in direct citation.

Contents

Intellectual Property Rights	2
Legal Notice	2
Modal verbs terminology.....	2
Foreword.....	5
1 Scope	7
2 References	7
3 Definitions, symbols and abbreviations	8
3.1 Definitions	8
3.2 Symbols.....	8
3.3 Abbreviations	8
4 Overview	8
4.1 Introduction	8
5 Services offered by the MNPF	9
5.1 Introduction	9
5.2 Nmpf_NPStatus Service.....	9
5.2.1 Service Description.....	9
5.2.2 Service Operations.....	9
5.2.2.1 Introduction.....	9
5.2.2.2 Get.....	9
5.2.2.2.1 General	9
5.2.2.2.2 MNPF Status information retrieval	9
6 API Definitions	10
6.1 Nmpf_NPStatus Service API	10
6.1.1 Introduction.....	10
6.1.2 Usage of HTTP.....	10
6.1.2.1 General	10
6.1.2.2 HTTP standard headers	11
6.1.2.2.1 General	11
6.1.2.2.2 Content type	11
6.1.2.3 HTTP custom headers	11
6.1.3 Resources.....	11
6.1.3.1 Overview.....	11
6.1.3.2 Resource: NPstatus.....	12
6.1.3.2.1 Description	12
6.1.3.2.2 Resource Definition.....	12
6.1.3.2.3 Resource Standard Methods	12
6.1.4 Custom Operations without associated resources	12
6.1.5 Notifications	12
6.1.6 Data Model	13
6.1.6.1 General	13
6.1.6.2 Structured data types	13
6.1.6.2.1 Introduction	13
6.1.6.2.2 Type: NpStatusInfo	13
6.1.6.3 Simple data types and enumerations	13
6.1.6.3.1 Introduction	13
6.1.6.3.2 Simple data types.....	13
6.1.6.4 Data types describing alternative data types or combinations of data types	14
6.1.6.5 Binary data	14
6.1.7 Error Handling	14
6.1.7.1 General	14
6.1.7.2 Protocol Errors.....	14
6.1.7.3 Application Errors.....	14

6.1.8	Feature negotiation	14
6.1.9	Security	14
Annex A (normative): OpenAPI specification		15
A.1	General	15
A.2	Nmnpf_NPstatus API	15
Annex B (informative): Withdrawn API versions		17
B.1	General	17
B.2	Nmnpf_NPstatus API	17
Annex C (informative): Change history		18
History		19

Foreword

This Technical Specification has been produced by the 3rd Generation Partnership Project (3GPP).

The contents of the present document are subject to continuing work within the TSG and may change following formal TSG approval. Should the TSG modify the contents of the present document, it will be re-released by the TSG with an identifying change of release date and an increase in version number as follows:

Version x.y.z

where:

- x the first digit:
 - 1 presented to TSG for information;
 - 2 presented to TSG for approval;
 - 3 or greater indicates TSG approved document under change control.
- y the second digit is incremented for all changes of substance, i.e. technical enhancements, corrections, updates, etc.
- z the third digit is incremented when editorial only changes have been incorporated in the document.

In the present document, modal verbs have the following meanings:

- shall** indicates a mandatory requirement to do something
- shall not** indicates an interdiction (prohibition) to do something

The constructions "shall" and "shall not" are confined to the context of normative provisions, and do not appear in Technical Reports.

The constructions "must" and "must not" are not used as substitutes for "shall" and "shall not". Their use is avoided insofar as possible, and they are not used in a normative context except in a direct citation from an external, referenced, non-3GPP document, or so as to maintain continuity of style when extending or modifying the provisions of such a referenced document.

- should** indicates a recommendation to do something
- should not** indicates a recommendation not to do something
- may** indicates permission to do something
- need not** indicates permission not to do something

The construction "may not" is ambiguous and is not used in normative elements. The unambiguous constructions "might not" or "shall not" are used instead, depending upon the meaning intended.

- can** indicates that something is possible
- cannot** indicates that something is impossible

The constructions "can" and "cannot" are not substitutes for "may" and "need not".

- will** indicates that something is certain or expected to happen as a result of action taken by an agency the behaviour of which is outside the scope of the present document
- will not** indicates that something is certain or expected not to happen as a result of action taken by an agency the behaviour of which is outside the scope of the present document
- might** indicates a likelihood that something will happen as a result of action taken by some agency the behaviour of which is outside the scope of the present document

might not indicates a likelihood that something will not happen as a result of action taken by some agency the behaviour of which is outside the scope of the present document

In addition:

is (or any other verb in the indicative mood) indicates a statement of fact

is not (or any other negative verb in the indicative mood) indicates a statement of fact

The constructions "is" and "is not" do not indicate requirements.

1 Scope

The present document specifies the stage 3 protocol and data model for the Nmnpf Service Based Interface. It provides stage 3 protocol definitions and message flows, and specifies the API for each service offered by the MNPF.

The 5G System stage 2 architecture and procedures are specified in 3GPP TS 23.501 [2] and 3GPP TS 23.502 [3].

The Technical Realization of the Service Based Architecture and the Principles and Guidelines for Services Definition are specified in 3GPP TS 29.500 [4] and 3GPP TS 29.501 [5].

Stage 2 requirements for the Nmnpf services are specified in 3GPP TS 23.540 [14].

2 References

The following documents contain provisions which, through reference in this text, constitute provisions of the present document.

- References are either specific (identified by date of publication, edition number, version number, etc.) or non-specific.
- For a specific reference, subsequent revisions do not apply.
- For a non-specific reference, the latest version applies. In the case of a reference to a 3GPP document (including a GSM document), a non-specific reference implicitly refers to the latest version of that document *in the same Release as the present document*.

- [1] 3GPP TR 21.905: "Vocabulary for 3GPP Specifications".
- [2] 3GPP TS 23.501: "System Architecture for the 5G System; Stage 2".
- [3] 3GPP TS 23.502: "Procedures for the 5G System; Stage 2".
- [4] 3GPP TS 29.500: "5G System; Technical Realization of Service Based Architecture; Stage 3".
- [5] 3GPP TS 29.501: "5G System; Principles and Guidelines for Services Definition; Stage 3".
- [6] OpenAPI: "OpenAPI Specification Version 3.0.0", <https://spec.openapis.org/oas/v3.0.0>.
- [7] 3GPP TR 21.900: "Technical Specification Group working methods".
- [8] 3GPP TS 33.501: "Security architecture and procedures for 5G system".
- [9] IETF RFC 6749: "The OAuth 2.0 Authorization Framework".
- [10] 3GPP TS 29.510: "5G System; Network Function Repository Services; Stage 3".
- [11] IETF RFC 9113: "HTTP/2".
- [12] IETF RFC 8259: "The JavaScript Object Notation (JSON) Data Interchange Format".
- [13] IETF RFC 9457: "Problem Details for HTTP APIs".
- [14] 3GPP TS 23.540: " Technical realization of Service Based Short Message Service; Stage 2".
- [15] 3GPP TS 29.571: "5G System; Common Data Types for Service Based Interfaces Stage 3".

3 Definitions, symbols and abbreviations

3.1 Definitions

For the purposes of the present document, the terms and definitions given in 3GPP TR 21.905 [1] and the following apply. A term defined in the present document takes precedence over the definition of the same term, if any, in 3GPP TR 21.905 [1].

Nmnpf: Service-based interface exhibited by the MNPF server

3.2 Symbols

For the purposes of the present document, the following symbols apply:

<symbol> <Explanation>

3.3 Abbreviations

For the purposes of the present document, the abbreviations given in 3GPP TR 21.905 [1] and the following apply. An abbreviation defined in the present document takes precedence over the definition of the same abbreviation, if any, in 3GPP TR 21.905 [1].

MNPF Mobile Number Portability Function

4 Overview

4.1 Introduction

Within the 5GC, the MNPF offers services to the SMS-GMSC, NRF and SCP via the Nmnpf service based interface (see 3GPP TS 23.501 [2], 3GPP TS 23.502 [3], and 3GPP TS 23.540 [14]).

Figure 4.1-1 provides the reference model (in service based interface representation and in reference point representation), with focus on the MNPF.

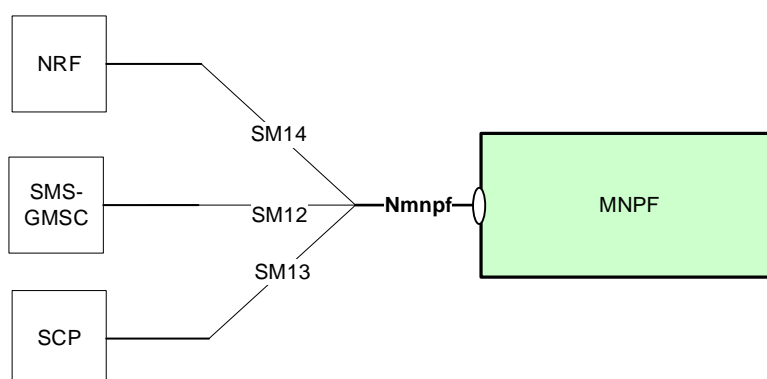

Figure 4.1-1: Reference model – MNPF

The functionalities supported by the MNPF are listed in clause 6.7 of 3GPP TS 23.540 [14].

5 Services offered by the MNPF

5.1 Introduction

The MNPF offers the following services via the Nmnpf interface:

- Nmnpf_NPStatus Service

Table 5.1-1 summarizes the corresponding APIs defined for this specification.

Table 5.1-1: API Descriptions

Service Name	Clause	Description	OpenAPI Specification File	apiName	Annex
Nmnpf_NPStatus	6.1	MNPF Number portability Status Service	TS29578_Nmnpf_NPStatus.yaml	nmnpf-npstatus	A.2

5.2 Nmnpf_NPStatus Service

5.2.1 Service Description

See 3GPP TS 23.540 [14] clause 6.7.1.

5.2.2 Service Operations

5.2.2.1 Introduction

For the Nmnpf_NPStatus service the following service operations are defined:

- Get

The Nmnpf_NPStatus Service is used by Consumer NFs (SMS-GMSC, NRF, SCP) to retrieve the UE's subscription network by means of the Get service operation.

5.2.2.2 Get

5.2.2.2.1 General

This clause provides a general description of the Get service operation.

5.2.2.2.2 MNPF Status information retrieval

Figure 5.2.2.2-1 shows a scenario where the NF service consumer (e.g. SMS-GMSC, NRF, SCP) sends a request to the MNPF to receive the UE's Subscription Network (see also clause 5.1.7.2, clause 5.1.7.3 and clause 5.1.7.4 of 3GPP TS 23.540 [14]). The request contains the UE's identity (*/gpsi*).

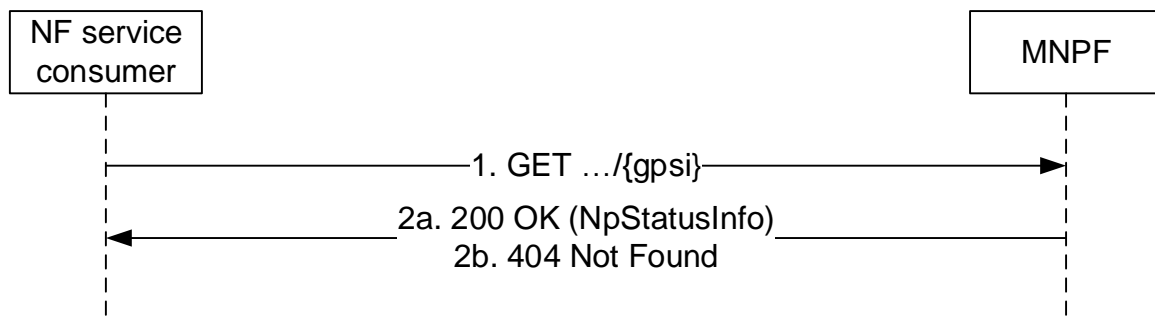

Figure 5.2.2.2-1: Requesting a UE's NP status

1. The NF service consumer (e.g. SMS-GMSC, NRF, SCP) sends a GET request to the resource representing the UE's number portability status.
- 2a. On success, the MNPf responds with "200 OK" with the message body containing the UE's Number Portability Status Information.
- 2b. If there is no valid information for the UE, HTTP status code "404 Not Found" shall be returned including additional error information in the response body (in the "ProblemDetails" element).

On failure, the appropriate HTTP status code indicating the error shall be returned and appropriate additional error information should be returned in the GET response body.

6 API Definitions

6.1 Nmpf_NPStatus Service API

6.1.1 Introduction

The Nmpf_NPStatus service shall use the Nmpf_NPStatus API.

The API URI of the Nmpf_NPStatus API shall be:

{apiRoot}/<apiName>/<apiVersion>

The request URIs used in HTTP requests from the NF service consumer towards the NF service producer shall have the Resource URI structure defined in clause 4.4.1 of 3GPP TS 29.501 [5], i.e.:

{apiRoot}/<apiName>/<apiVersion>/<apiSpecificResourceUriPart>

with the following components:

- The {apiRoot} shall be set as described in 3GPP TS 29.501 [5].
- The <apiName> shall be "nmpf-npstatus".
- The <apiVersion> shall be "v1".
- The <apiSpecificResourceUriPart> shall be set as described in clause 6.1.3.

6.1.2 Usage of HTTP

6.1.2.1 General

HTTP/2, IETF RFC 9113 [11], shall be used as specified in clause 5 of 3GPP TS 29.500 [4].

HTTP/2 shall be transported as specified in clause 5.3 of 3GPP TS 29.500 [4].

The OpenAPI [6] specification of HTTP messages and content bodies for the Nmnpf_NPStatus API is contained in Annex A.

6.1.2.2 HTTP standard headers

6.1.2.2.1 General

See clause 5.2.2 of 3GPP TS 29.500 [4] for the usage of HTTP standard headers.

6.1.2.2.2 Content type

JSON, IETF RFC 8259 [12], shall be used as content type of the HTTP bodies specified in the present specification as specified in clause 5.4 of 3GPP TS 29.500 [4]. The use of the JSON format shall be signalled by the content type "application/json".

"Problem Details" JSON object shall be used to indicate additional details of the error in a HTTP response body and shall be signalled by the content type "application/problem+json", as defined in IETF RFC 9457 [13].

6.1.2.3 HTTP custom headers

The mandatory HTTP custom header fields specified in clause 5.2.3.2 of 3GPP TS 29.500 [4] shall be supported, and the optional HTTP custom header fields specified in clause 5.2.3.3 of 3GPP TS 29.500 [4] may be supported.

6.1.3 Resources

6.1.3.1 Overview

This clause describes the structure for the Resource URIs and the resources and methods used for the service.

Figure 6.1.3.1-1 depicts the resource URIs structure for the Nmnpf_NPStatus API.

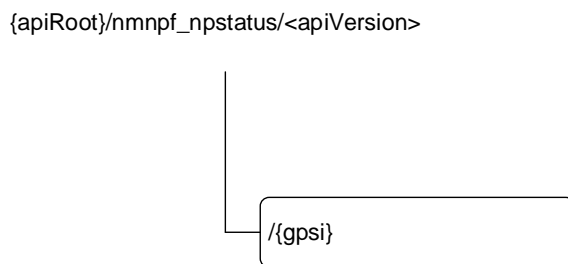

Figure 6.1.3.1-1: Resource URI structure of the Nmnpf_NPStatus API

Table 6.1.3.1-1 provides an overview of the resources and applicable HTTP methods.

Table 6.1.3.1-1: Resources and methods overview

Resource purpose/name	Resource URI (relative path after API URI)	HTTP method or custom operation	Description (service operation)
NPstatus	/{gpsi}	GET	Retrieve the NP status of the GPSI

6.1.3.2 Resource: NPstatus

6.1.3.2.1 Description

This resource represents the Number Portability status for a GPSI.

6.1.3.2.2 Resource Definition

Resource URI: {apiRoot}/nmmpf-npstatus/<apiVersion>/{gpsi}

This resource shall support the resource URI variables defined in table 6.1.3.2.2-1.

Table 6.1.3.2.2-1: Resource URI variables for this resource

Name	Data type	Definition
apiRoot	string	See clause 6.1.1
gpsi	Gpsi	See 3GPP TS 29.571 [15]; the only valid format is MSISDN

6.1.3.2.3 Resource Standard Methods

6.1.3.2.3.1 GET

This method shall support the URI query parameters specified in table 6.1.3.2.3.1-1.

Table 6.1.3.2.3.1-1: URI query parameters supported by the GET method on this resource

Name	Data type	P	Cardinality	Description	Applicability
n/a					

This method shall support the request data structures specified in table 6.1.3.2.3.1-2 and the response data structures and response codes specified in table 6.1.3.2.3.1-3.

Table 6.1.3.2.3.1-2: Data structures supported by the GET Request Body on this resource

Data type	P	Cardinality	Description
n/a			

Table 6.1.3.2.3.1-3: Data structures supported by the GET Response Body on this resource

Data type	P	Cardinality	Response codes	Description
NpStatusInfo	M	1	200 OK	Upon success, the response body contains the Number Portability Status information.
ProblemDetails	O	0..1	404 Not Found	The "cause" attribute may be used to indicate one of the following application errors: - GPSI_NOT_FOUND
NOTE: The mandatory HTTP error status code for the GET method listed in Table 5.2.7.1-1 of 3GPP TS 29.500 [4] also apply.				

6.1.4 Custom Operations without associated resources

None.

6.1.5 Notifications

None.

6.1.6 Data Model

6.1.6.1 General

This clause specifies the application data model supported by the API.

Table 6.1.6.1-1 specifies the data types defined for the Nmpf_NPStatus service based interface protocol.

Table 6.1.6.1-1: Nmpf_NPStatus specific Data Types

Data type	Clause defined	Description	Applicability
NpStatusInfo	6.1.6.2.2	Number Portability Status Information	

Table 6.1.6.1-2 specifies data types re-used by the Nmpf_NPStatus service based interface protocol from other specifications, including a reference to their respective specifications and when needed, a short description of their use within the Nmpf_NPStatus service based interface.

Table 6.1.6.1-2: Nmpf_NPStatus re-used Data Types

Data type	Reference	Comments	Applicability
Gpsi	3GPP TS 29.571 [15]	General Public Subscription Identifier	
ProblemDetails	3GPP TS 29.571 [15]	Error description	
PlmnId	3GPP TS 29.571 [15]	PLMN Identity	

6.1.6.2 Structured data types

6.1.6.2.1 Introduction

This clause defines the structures to be used in resource representations.

6.1.6.2.2 Type: NpStatusInfo

Table 6.1.6.2.2-1: Definition of type NpStatusInfo

Attribute name	Data type	P	Cardinality	Description	Applicability
subscriptionNetwork	PlmnId	M	1	Identifies the GPSI's subscriptionNetwork	
tbc					

6.1.6.3 Simple data types and enumerations

6.1.6.3.1 Introduction

This clause defines simple data types and enumerations that can be referenced from data structures defined in the previous clauses.

6.1.6.3.2 Simple data types

The simple data types defined in table 6.1.6.3.2-1 shall be supported.

Table 6.1.6.3.2-1: Simple data types

Type Name	Type Definition	Description	Applicability

6.1.6.4 Data types describing alternative data types or combinations of data types

None.

6.1.6.5 Binary data

None.

6.1.7 Error Handling

6.1.7.1 General

For the Nmnpf_NPStatus API, HTTP error responses shall be supported as specified in clause 4.8 of 3GPP TS 29.501 [5]. Protocol errors and application errors specified in table 5.2.7.2-1 of 3GPP TS 29.500 [4] shall be supported for an HTTP method if the corresponding HTTP status codes are specified as mandatory for that HTTP method in table 5.2.7.1-1 of 3GPP TS 29.500 [4].

In addition, the requirements in the following clauses are applicable for the Nmnpf_NPStatus API.

6.1.7.2 Protocol Errors

Protocol errors handling shall be supported as specified in clause 5.2.7 of 3GPP TS 29.500 [4].

6.1.7.3 Application Errors

The application errors defined for the Nmnpf_NPStatus service are listed in Table 6.1.7.3-1.

Table 6.1.7.3-1: Application errors

Application Error	HTTP status code	Description

6.1.8 Feature negotiation

The optional features in table 6.1.8-1 are defined for the Nmnpf_NPStatus API. They shall be negotiated using the extensibility mechanism defined in clause 6.6 of 3GPP TS 29.500 [4].

Table 6.1.8-1: Supported Features

Feature number	Feature Name	Description

6.1.9 Security

As indicated in 3GPP TS 33.501 [8] and 3GPP TS 29.500 [4], the access to the Nmnpf_NPStatus API may be authorized by means of the OAuth2 protocol (see IETF RFC 6749 [9]), based on local configuration, using the "Client Credentials" authorization grant, where the NRF (see 3GPP TS 29.510 [10]) plays the role of the authorization server.

If OAuth2 is used, an NF Service Consumer, prior to consuming services offered by the Nmnpf_NPStatus API, shall obtain a "token" from the authorization server, by invoking the Access Token Request service, as described in 3GPP TS 29.510 [10], clause 5.4.2.2.

NOTE: When multiple NRFs are deployed in a network, the NRF used as authorization server is the same NRF that the NF Service Consumer used for discovering the Nmnpf_NPStatus service.

The Nmnpf_NPStatus API defines a single scope "nmnpf-npstatus" for the entire service, and it does not define any additional scopes at resource or operation level.

Annex A (normative): OpenAPI specification

A.1 General

This Annex specifies the formal definition of the API(s) defined in the present specification. It consists of OpenAPI specifications in YAML format.

This Annex takes precedence when being discrepant to other parts of the specification with respect to the encoding of information elements and methods within the API(s).

NOTE 1: The semantics and procedures, as well as conditions, e.g. for the applicability and allowed combinations of attributes or values, not expressed in the OpenAPI definitions but defined in other parts of the specification also apply.

Informative copies of the OpenAPI specification files contained in this 3GPP Technical Specification are available on a Git-based repository that uses the GitLab software version control system (see clause 5.3.1 of 3GPP TS 29.501 [5] and clause 5B of 3GPP TR 21.900 [7]).

A.2 Nmnpf_NPStatus API

```

openapi: 3.0.0
info:
  title: 'Nmnpf_NPStatus'
  version: '1.2.0-alpha.3'
  description: |
    Nmnpf Number Portability Status Service.
    © 2025, 3GPP Organizational Partners (ARIB, ATIS, CCSA, ETSI, TSDSI, TTA, TTC).
    All rights reserved.
externalDocs:
  description: 3GPP TS 29.578 V19.2.0; Mobile Number Portability Services.
  url: https://www.3gpp.org/ftp/Specs/archive/29_series/29.578/
servers:
  - url: '{apiRoot}/nmnpf-npstatus/v1'
    variables:
      apiRoot:
        default: https://example.com
        description: apiRoot as defined in clause 4.4 of 3GPP TS 29.501
security:
  - {}
  - oAuth2ClientCredentials:
      - nmnpf-npstatus
paths:
  /{gpsi}:
    get:
      summary: Retrieves the Number Portability status of the UE
      operationId: GetNumberPortabilityStatus
      tags:
        - Number Portability Status (Document)
      parameters:
        - name: gpsi
          in: path
          description: GPSI of the UE
          required: true
          schema:
            $ref: 'TS29571_CommonData.yaml#/components/schemas/Gpsi'
      responses:
        '200':
          description: Expected response to a valid request
          content:
            application/json:
              schema:
                $ref: '#/components/schemas/NpStatusInfo'
        '400':
          $ref: 'TS29571_CommonData.yaml#/components/responses/400'
        '401':

```

```
  $ref: 'TS29571_CommonData.yaml#/components/responses/401'
'403':
  $ref: 'TS29571_CommonData.yaml#/components/responses/403'
'404':
  description: GPSI Not Found
  content:
    application/problem+json:
      schema:
        $ref: 'TS29571_CommonData.yaml#/components/schemas/ProblemDetails'
'406':
  $ref: 'TS29571_CommonData.yaml#/components/responses/406'
'429':
  $ref: 'TS29571_CommonData.yaml#/components/responses/429'
'500':
  $ref: 'TS29571_CommonData.yaml#/components/responses/500'
'502':
  $ref: 'TS29571_CommonData.yaml#/components/responses/502'
'503':
  $ref: 'TS29571_CommonData.yaml#/components/responses/503'
default:
  description: Unexpected error
```

```
components:
  securitySchemes:
    oAuth2ClientCredentials:
      type: oauth2
      flows:
        clientCredentials:
          tokenUrl: '{nrfApiRoot}/oauth2/token'
          scopes:
            nmmpf-npstatus: Access to the nmmpf-npstatus API
  schemas:
```

STRUCTURED TYPES:

```
  NpStatusInfo:
    description: Contains the Subscription Network
    type: object
    required:
      - subscriptionNetwork
    properties:
      subscriptionNetwork:
        $ref: 'TS29571_CommonData.yaml#/components/schemas/PlmnId'
```

SIMPLE TYPES:

ENUMS:

Annex B (informative): Withdrawn API versions

B.1 General

This Annex lists withdrawn API versions of the APIs defined in the present specification. 3GPP TS 29.501 [5] clause 4.3.1.6 describes the withdrawal of API versions.

B.2 Nmpf_NPstatus API

The API versions listed in table B.2-1 are withdrawn for the Nmpf_NPstatus API.

Table B.2-1: Withdrawn API versions of the Nmpf_NPstatus service

API version number	Remarks

Annex C (informative): Change history

Change history							
Date	Meeting	TDoc	CR	Re v	Cat	Subject/Comment	New version
2022-02	CT4#108e	C4-221536				Initial draft	0.1.0
2022-04	CT4#109e	C4-222270				Pseudo-CR on SCP and NRF supported	0.2.0
2022-05	CT4#110e	C4-223092				Pseudo-CR on MNPf name	0.3.0
2022-05	CT4#110e	C4-223093				Pseudo-CR on Document Clean Up	0.3.0
2022-05	CT4#110e	C4-223354				Pseudo-CR on Remove the apiVersion placeholder from the resource URI variables table	0.3.0
2022-06	CT#96	CP-221079				TS presented for information and approval	1.0.0
2022-06	CT#96	CP-221079				TS approved at CT#95	17.0.0
2022-09	CT#97e	CP-222027	0003		F	Alignment on the service name used with template	17.1.0
2022-09	CT#97e	CP-222027	0004	1	F	Update the reference model	17.1.0
2022-12	CT#98e	CP-223027	0006	1	F	Missing Mandatory Status Codes in OpenAPI	18.0.0
2022-12	CT#98e	CP-223033	0007		F	29.578 Rel-18 API version and External doc update	18.0.0
2023-12	CT#102	CP-233028	0008	1	F	HTTP RFCs obsoleted by IETF RFC 9110, 9111 and 9113	18.1.0
2023-12	CT#102	CP-233029	0009		F	ProblemDetails RFC 7807 obsoleted by 9457	18.1.0
2024-06	CT#104	CP-241052	0010		F	29.578 Rel-18 API version and External doc update	18.2.0
2024-09	CT#105	CP-242030	0011		F	Complex Types	19.0.0
2024-09	CT#105	CP-242038	0012		F	29.578 Rel-19 API version and External doc update	19.0.0
2025-06	CT#108	CP-251079	0013		F	29.578 Rel-19 API version and External doc update	19.1.0
2025-09	CT#109	CP-252176	0014		F	API version and External doc update	19.2.0

History

Document history		
V19.2.0	January 2026	Publication