

ETSI TS 132 254 V19.2.1 (2025-12)



TECHNICAL SPECIFICATION

**LTE;
5G;
Telecommunication management;
Charging management;
Exposure function Northbound
Application Program Interfaces (APIs) charging
(3GPP TS 32.254 version 19.2.1 Release 19)**



A GLOBAL INITIATIVE

Reference

RTS/TSGS-0532254vj21

Keywords

5G,LTE

ETSI

650 Route des Lucioles
F-06921 Sophia Antipolis Cedex - FRANCE

Tel.: +33 4 92 94 42 00 Fax: +33 4 93 65 47 16

Siret N° 348 623 562 00017 - APE 7112B
Association à but non lucratif enregistrée à la
Sous-Préfecture de Grasse (06) N° w061004871

Important notice

The present document can be downloaded from the
[ETSI Search & Browse Standards application](#).

The present document may be made available in electronic versions and/or in print. The content of any electronic and/or print versions of the present document shall not be modified without the prior written authorization of ETSI. In case of any existing or perceived difference in contents between such versions and/or in print, the prevailing version of an ETSI deliverable is the one made publicly available in PDF format on [ETSI deliver repository](#).

Users should be aware that the present document may be revised or have its status changed, this information is available in the [Milestones listing](#).

If you find errors in the present document, please send your comments to the relevant service listed under [Committee Support Staff](#).

If you find a security vulnerability in the present document, please report it through our [Coordinated Vulnerability Disclosure \(CVD\)](#) program.

Notice of disclaimer & limitation of liability

The information provided in the present deliverable is directed solely to professionals who have the appropriate degree of experience to understand and interpret its content in accordance with generally accepted engineering or other professional standard and applicable regulations.

No recommendation as to products and services or vendors is made or should be implied.

No representation or warranty is made that this deliverable is technically accurate or sufficient or conforms to any law and/or governmental rule and/or regulation and further, no representation or warranty is made of merchantability or fitness for any particular purpose or against infringement of intellectual property rights.

In no event shall ETSI be held liable for loss of profits or any other incidental or consequential damages.

Any software contained in this deliverable is provided "AS IS" with no warranties, express or implied, including but not limited to, the warranties of merchantability, fitness for a particular purpose and non-infringement of intellectual property rights and ETSI shall not be held liable in any event for any damages whatsoever (including, without limitation, damages for loss of profits, business interruption, loss of information, or any other pecuniary loss) arising out of or related to the use of or inability to use the software.

Copyright Notification

No part may be reproduced or utilized in any form or by any means, electronic or mechanical, including photocopying and microfilm except as authorized by written permission of ETSI.

The content of the PDF version shall not be modified without the written authorization of ETSI.

The copyright and the foregoing restriction extend to reproduction in all media.

© ETSI 2025.
All rights reserved.

Intellectual Property Rights

Essential patents

IPRs essential or potentially essential to normative deliverables may have been declared to ETSI. The declarations pertaining to these essential IPRs, if any, are publicly available for **ETSI members and non-members**, and can be found in ETSI SR 000 314: "*Intellectual Property Rights (IPRs); Essential, or potentially Essential, IPRs notified to ETSI in respect of ETSI standards*", which is available from the ETSI Secretariat. Latest updates are available on the [ETSI IPR online database](#).

Pursuant to the ETSI Directives including the ETSI IPR Policy, no investigation regarding the essentiality of IPRs, including IPR searches, has been carried out by ETSI. No guarantee can be given as to the existence of other IPRs not referenced in ETSI SR 000 314 (or the updates on the ETSI Web server) which are, or may be, or may become, essential to the present document.

Trademarks

The present document may include trademarks and/or tradenames which are asserted and/or registered by their owners. ETSI claims no ownership of these except for any which are indicated as being the property of ETSI, and conveys no right to use or reproduce any trademark and/or tradename. Mention of those trademarks in the present document does not constitute an endorsement by ETSI of products, services or organizations associated with those trademarks.

DECT™, **PLUGTESTS™**, **UMTS™** and the ETSI logo are trademarks of ETSI registered for the benefit of its Members. **3GPP™**, **LTE™** and **5G™** logo are trademarks of ETSI registered for the benefit of its Members and of the 3GPP Organizational Partners. **oneM2M™** logo is a trademark of ETSI registered for the benefit of its Members and of the oneM2M Partners. **GSM®** and the GSM logo are trademarks registered and owned by the GSM Association.

Legal Notice

This Technical Specification (TS) has been produced by ETSI 3rd Generation Partnership Project (3GPP).

The present document may refer to technical specifications or reports using their 3GPP identities. These shall be interpreted as being references to the corresponding ETSI deliverables.

The cross reference between 3GPP and ETSI identities can be found at [3GPP to ETSI numbering cross-referencing](#).

Modal verbs terminology

In the present document "**shall**", "**shall not**", "**should**", "**should not**", "**may**", "**need not**", "**will**", "**will not**", "**can**" and "**cannot**" are to be interpreted as described in clause 3.2 of the [ETSI Drafting Rules](#) (Verbal forms for the expression of provisions).

"**must**" and "**must not**" are **NOT** allowed in ETSI deliverables except when used in direct citation.

Contents

Intellectual Property Rights	2
Legal Notice	2
Modal verbs terminology.....	2
Foreword.....	6
1 Scope	7
2 References	7
3 Definitions, symbols and abbreviations	8
3.1 Definitions	8
3.2 Symbols.....	9
3.3 Abbreviations	9
4 Architecture considerations	9
4.1 High-level Service Exposure Function architecture	9
4.2 Northbound API offline charging architecture	10
4.3 Northbound API online charging architecture.....	11
4.4 Northbound API converged charging architecture	12
5 Northbound API charging principles and scenarios	13
5.1 Northbound API charging principles.....	13
5.1.0 General.....	13
5.1.1 Northbound API procedures	13
5.1.2 AI/ML support	14
5.2 Northbound API offline charging scenarios	15
5.2.1 Basic principles.....	15
5.2.2 Rf message flows	15
5.2.2.1 Triggers for charging events from SCEF	15
5.2.3 CDR generation	15
5.2.3.1 Introduction	15
5.2.3.2 Triggers for EA-SCE-CDR creation and closure	16
5.2.3.2.1 Triggers for EA-SCE-CDR generation.....	16
5.2.4 Ga record transfer flows	16
5.2.5 Bea CDR file transfer	16
5.3 Northbound API online charging scenarios.....	16
5.3.1 Basic principles.....	16
5.3.1.1 General	16
5.3.2 Ro message flows	16
5.3.2.1 Event Based Charging.....	16
5.4 Northbound API converged online and offline charging scenarios	19
5.4.1 Basic principles.....	19
5.4.1.1 General	19
5.4.1.2 Applicable Triggers in the NEF and CCF	20
5.4.1.2.1 General	20
5.4.2 Message flows	21
5.4.2.1 Introduction.....	21
5.4.2.2 API Invocation - IEC	21
5.4.2.3 API Invocation - ECUR	21
5.4.2.4 API Notification - IEC	22
5.4.2.5 API event Notification - ECUR	23
5.4.2.6 API Invocation - PEC.....	24
5.4.2.7 API Notification - PEC	25
5.4.2.8 CAPIF Invoker and Provider Request (PEC).....	26
5.4.3 CDR generation	27
5.4.3.1 Introduction.....	27
5.4.3.2 Triggers for CHF CDR.....	27
5.4.3.2.1 General	27

5.4.3.2.2	Triggers for CHF CDR generation	27
5.4.3.2.3	Triggers for CHF CDR opening	27
5.4.3.2.4	Triggers for CHF CDR closure	27
5.4.4	Ga record transfer flows	27
5.4.5	Bea CDR file transfer	27
6.	Definition of charging information	28
6.1	Data description for Northbound API offline charging	28
6.1.1	Rf message contents.....	28
6.1.1.1	General.....	28
6.1.1.2	Charging data request message	28
6.1.1.3	Charging data response message.....	29
6.1.2	Ga message contents	29
6.1.3	CDR description on the Bea interface.....	29
6.1.3.1	General	29
6.1.3.2	Exposure Function API charging data (EA-SCE-CDR).....	29
6.2	Data description for Northbound API online charging.....	30
6.2.1	Ro message contents	30
6.2.1.0	Introduction.....	30
6.2.1.1	Summary of message formats	30
6.2.1.2	Structure for the Credit-Control message formats.....	31
6.2.1.2.1	Debit/Reserve Units Request message	31
6.2.1.2.2	Debit / Reserve Units Response message.....	31
6.2a	Data description for NEF converged charging	32
6.2a.1	Message contents	32
6.2a.1.1	General	32
6.2a.1.2	Structure for the converged charging message formats.....	33
6.2a.1.2.1	Charging Data Request message	33
6.2a.1.2.2	Charging Data Response message	33
6.2a.2	G _a message contents	33
6.2a.3	CDR description on the B _{ea} interface.....	34
6.2a.3.1	General	34
6.2a.3.2	NEF charging CHF CDR data.....	34
6.3	Northbound API charging specific parameters.....	35
6.3.1	Definition of Northbound API charging information	35
6.3.1.1	Exposure Function API charging information assignment for Service Information	35
6.3.1.2	Definition of the Exposure Function API Information.....	35
6.3.1.3	Supported features.....	36
6.3.1.4	Definition of the NEF API Information	36
6.3.1.4.1	Definition of the NEF API Charging Information.....	36
6.3.2	Detailed message format for offline charging.....	37
6.3.3	Detailed message format for online charging	38
6.3.4	Detailed message format for converged charging.....	40
6.4	Bindings for Northbound API offline charging.....	42
6.5	Bindings for NEF Northbound API converged charging	42
6.6	Data description for CAPIF Core Function converged charging.....	42
6.6.1	Message contents	42
6.6.1.1	General	42
6.6.2	G _a message contents	43
6.6.3	CDR description on the B _{ea} interface.....	43
6.6.3.1	General	43
Annex A (normative):	Charging characteristics	44
A.1	General	44
Annex B (normative):	Support 5G VN group management charging	45
B.1	General	45
B.2	Charging Architecture for 5G VN group management charging	45
B.2.1	General	45
B.2.1.1	Logical Charging architecture - CEF based charging	45

B.2.2	Void.....	46
B.2.3	Charging principles and scenarios.....	46
B.2.3.1	Basic principles.....	46
B.2.3.2	Applicable triggers in 5G VN group management charging.....	46
B.2.3.2.1	5G VN group management charging via UDM	46
B.2.3.3	Message flows	47
B.2.3.3.1	5G VN group management charging via UDM	47
B.2.3.4	CDR generation	47
B.2.4	Charging Information.....	47
B.2.4.1	Data description for 5G VN group management charging	47
B.2.4.2	Definition of 5G VN group management charging information.....	49
B.2.4.3	Detailed message format for converged charging.....	49
B.2.5	Bindings for 5G VN group management converged charging	50
Annex C (informative): PlantUML source code		51
C.1	Procedures for Northbound API converged online and offline charging scenarios	51
C.1.1	CAPIF Invoker and Provider Request (PEC)	51
Annex D (informative): Change history		52
History		53

Foreword

This Technical Specification has been produced by the 3rd Generation Partnership Project (3GPP).

The contents of the present document are subject to continuing work within the TSG and may change following formal TSG approval. Should the TSG modify the contents of the present document, it will be re-released by the TSG with an identifying change of release date and an increase in version number as follows:

Version x.y.z

where:

x the first digit:

1 presented to TSG for information;

2 presented to TSG for approval;

3 or greater indicates TSG approved document under change control.

Y the second digit is incremented for all changes of substance, i.e. technical enhancements, corrections, updates, etc.

z the third digit is incremented when editorial only changes have been incorporated in the document.

1 Scope

The present document is part of a series of documents that specify charging functionality and charging management in 3GPP networks. The 3GPP core network charging architecture and principles are specified in TS 32.240 [1], which provides an umbrella for other charging management TSs that specify:

- the content of the CDRs per domain / subsystem / service (offline charging);
- the content of real-time charging messages per domain / subsystem / service (online charging);
- the functionality of online and offline charging for those domains / subsystems / services;
- the interfaces that are used in the charging framework to transfer the charging information (i.e. CDRs or charging events).

The complete document structure for these TSs is defined in TS 32.240 [1].

The present document specifies the offline, online and converged charging description for Northbound Application Program Interfaces (API), based on the functional stage 2 description in TS 23.682 [243] for transaction over T8 reference point between SCEF and SCS/AS and in TS 23.501 [200] for Network Exposure Function (NEF). This charging description includes the offline, online and converged charging architecture and scenarios specific to Northbound Application Program Interfaces (API), as well as the mapping of the common 3GPP charging architecture specified in TS 32.240 [1] onto the Northbound Application Program Interfaces (API). It further specifies the structure and content of the CDRs for offline charging. The present document is related to other 3GPP charging TSs as follows:

- The common 3GPP charging architecture is specified in TS 32.240 [1].
- The parameters, abstract syntax and encoding rules for the CDRs are specified in TS 32.298 [51].
- A transaction based mechanism for the transfer of CDRs within the network is specified in TS 32.295 [54].
- The file based mechanism used to transfer the CDRs from the network to the operator's billing domain (e.g. the billing system or a mediation device) is specified in TS 32.297 [52].
- The 3GPP Diameter application that is used for Northbound Application Program Interfaces (API) offline and online charging is specified in TS 32.299 [50].
- The services, operations and procedures of charging, using Service Based Interface are specified in TS 32.290 [57].
- The charging service of 5G system is specified in TS 32.291 [58].

2 References

The following documents contain provisions which, through reference in this text, constitute provisions of the present document.

- References are either specific (identified by date of publication, edition number, version number, etc.) or non-specific.
- For a specific reference, subsequent revisions do not apply.
- For a non-specific reference, the latest version applies. In the case of a reference to a 3GPP document (including a GSM document), a non-specific reference implicitly refers to the latest version of that document *in the same Release as the present document*.

[1] 3GPP TS 32.240: "Telecommunication management; Charging management; Charging architecture and principles".

[2] – [49] Void.

[50] 3GPP TS 32.299: "Telecommunication management; Charging management; Diameter charging application".

- [51] 3GPP TS 32.298: "Telecommunication management; Charging management; Charging Data Record (CDR) parameter description".
- [52] 3GPP TS 32.297: "Telecommunication management; Charging management; Charging Data Record (CDR) file format and transfer".
- [53] 3GPP TS 32.296: "Telecommunication management; Charging management; Online Charging System (OCS): Applications and interfaces".
- [54] 3GPP TS 32.295: "Telecommunication management; Charging management; Charging Data Record (CDR) transfer".
- [55] – [56] Void.
- [57] 3GPP TS 32.290: "Telecommunication management; Charging management; 5G system; Services, operations and procedures of charging using Service Based Interface (SBI)".
- [58] 3GPP TS 32.291: "Telecommunication management; Charging management; 5G system; Charging service, stage 3".
- [59] – [99] Void.
- [100] 3GPP TR 21.905: "Vocabulary for 3GPP Specifications".
- [101] – [199] Void
- [200] 3GPP TS 23.501: "System Architecture for the 5G System".
- [202] 3GPP TS 23.222: "Common API Framework for 3GPP Northbound APIs".
- [203]– [229] Void
- [230] 3GPP TS 29.122: "T8 reference point for northbound Application Programming Interfaces (APIs)".
- [231] 3GPP TS 29.522: "5G System; Network Exposure Function Northbound APIs; Stage 3".
- [232] 3GPP TS 29.222: "Common API Framework for 3GPP Northbound APIs".
- [233] – [235] Void
- [236] 3GPP TS 29.503: "5G System; Unified Data Management Services; Stage 3".
- [237] – [242] Void
- [243] 3GPP TS 23.682: "Architecture enhancements to facilitate communications with packet data networks and applications".
- [244] – [299] Void
- [300] – [399] Void.

3 Definitions, symbols and abbreviations

3.1 Definitions

For the purposes of the present document, the terms and definitions given in 3GPP TR 21.905 [100], TS 32.240 [1] and the following apply. A term defined in the present document takes precedence over the definition of the same term, if any, in either 3GPP TR 21.905 [100] or TS 32.240 [1].

3.2 Symbols

For the purposes of the present document, the following symbols apply:

Bea	Reference point for the CDR file transfer from the Exposure function API CGF to the BD.
Ga	Reference point for CDR transfer between a CDF and the CGF.
Nchf	Service based interface exhibited by CHF.
N44	Reference point between the NEF and the CHF
Rf	Offline charging reference point between a SCEF and the CDF.
Ro	Online charging reference point between a SCEF and the CDF.
T8	Reference point between the SCEF and SCS/AS.

3.3 Abbreviations

For the purposes of the present document, the abbreviations given in 3GPP TR 21.905 [100] and the following apply. An abbreviation defined in the present document takes precedence over the definition of the same abbreviation, if any, in 3GPP TR 21.905 [100].

AI/ML	Artificial Intelligence/Machine Learning
AS	Application Server
BD	Billing Domain
CAPIF	Common API Framework
CCF	CAPIF Core Function
CDF	Charging Data Function
CGF	Charging Gateway Function
CTF	Charging Trigger Function
ECUR	Event Charging with Unit Reservation
IE	Information Element
IEC	Immediate Event Charging
NEF	Network Exposure Function
PEC	Post Event Charging
SCEF	Service Capability Exposure Function
SCS	Services Capability Server
SGSN	Serving GPRS Support Node
RCAF	RAN Congestion Awareness Function

4 Architecture considerations

4.1 High-level Service Exposure Function architecture

The overall architecture and detailed description for Service Capability Exposure which enables the 3GPP network to securely expose its services and capabilities provided by 3GPP network interfaces to external 3rd party service provider applications are defined in 3GPP TS 23.682 [243], and figure 4.1.1 is highlighting T8 involved for interworking between SCEF and SCS/AS.

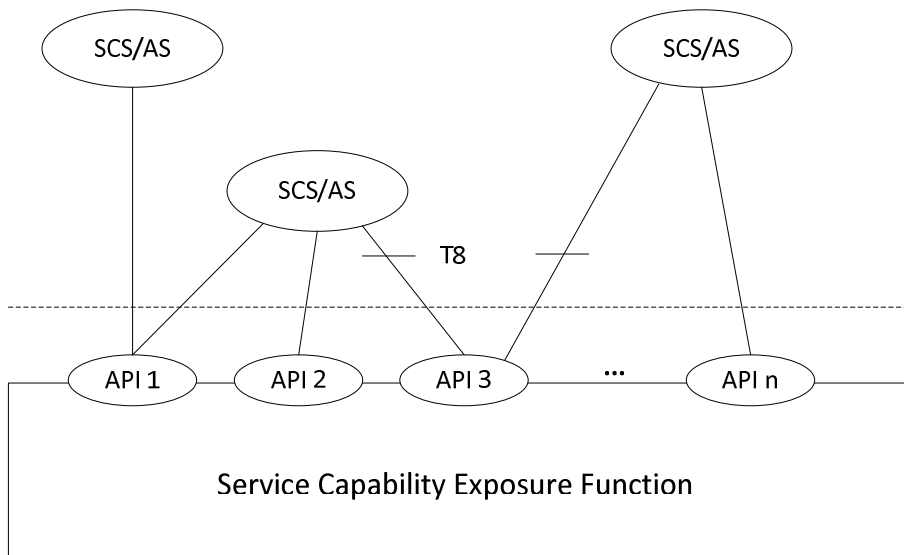

Figure 4.1.1: Northbound API of 3GPP Architecture Service Capability Exposure

The overall architecture and detailed description for Common API framework (CAPIF) for 3GPP northbound APIs that are applicable to any service APIs when used by northbound entities, as well as any interactions between the CAPIF and the service APIs themselves, are defined in 3GPP TS 23.222 [202]. The CAPIF applies to both EPS and 5GS, can be hosted within a PLMN or SNPN, and is independent of the underlying 3GPP access (e.g. E-UTRA, NR). The figure 4.1.2 describes the functional model for the CAPIF.

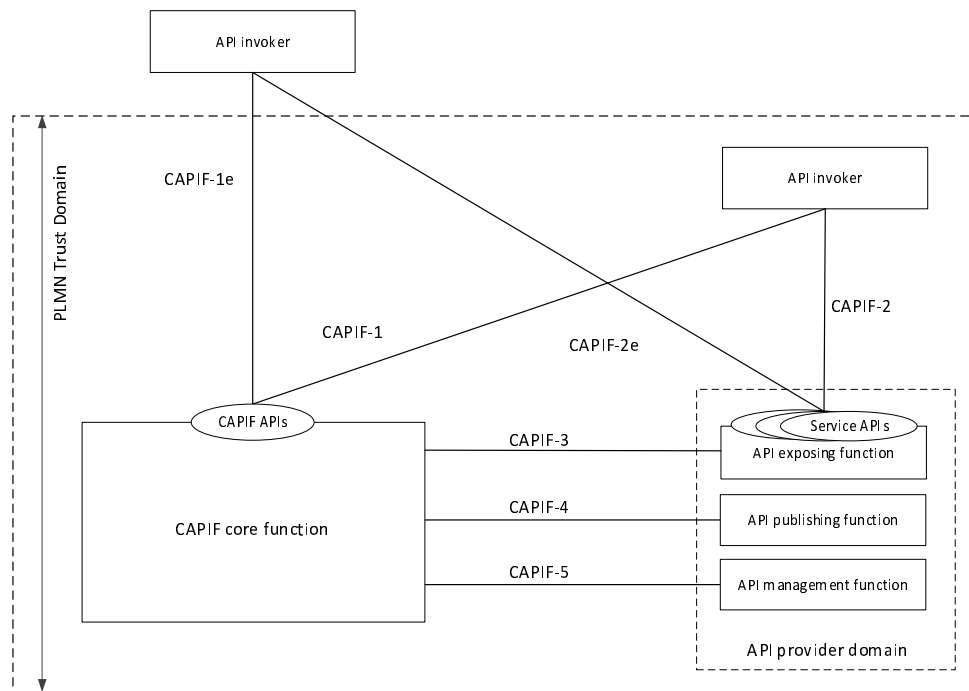

Figure 4.1.2: Functional model for the CAPIF

4.2 Northbound API offline charging architecture

As described in TS 32.240 [1], the CTF (an integrated component in each charging relevant NE) generates charging events and forwards them to the CDF. The CDF, in turn, generates CDRs which are then transferred to the CGF. Finally, the CGF creates CDR files and forwards them to the BD.

For offline charging, SCEF functioning as the CTF, may generate accounting metrics sets for Northbound Application Program Interfaces (APIs) CDRs:

- the SCEF, to record Application Program Interfaces transaction.

If the SCEF generating the charging information has an integrated CDF, then the SCEF can produce CDRs. The CGF may also be integrated in the SCEF, or it may exist as a physically separate entity. If the CGF is external to the SCEF /CDF, then the SCEF/CDF forwards the CDRs to the CGF across the Ga interface. If the CDF is external to the SCEF, the charging events are transferred from the SCEF to the CDF via the Rf interface specified in TS 32.299 [50].

When an external CGF is used, this CGF may also be used by other. It should be noted that the CGF may also be an integrated component of the BD – in this case, the Bea interface does not exist and is replaced by a proprietary solution internal to the BD.

Figure 4.2.1 depicts the architectural options described above.

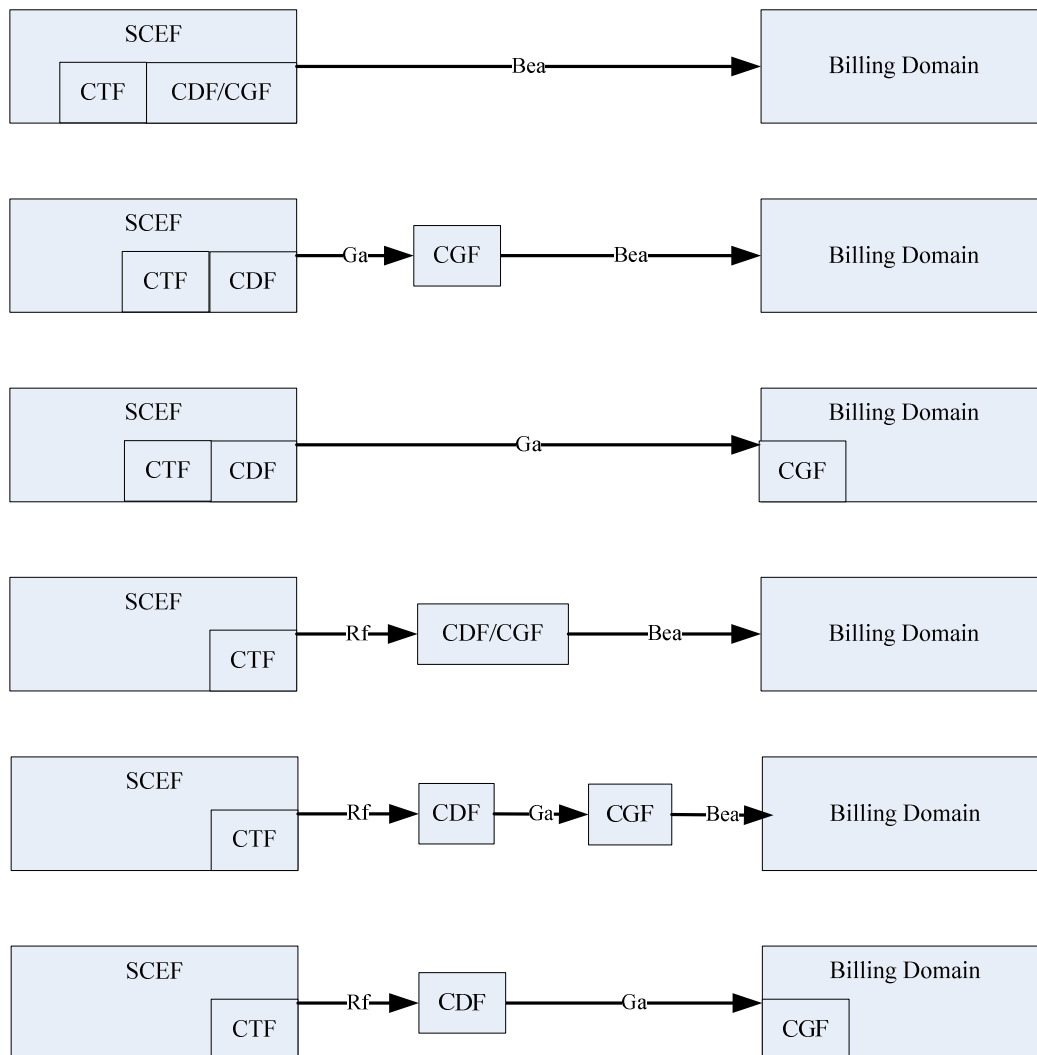

Figure 4.2.1: Northbound API offline charging architecture

It is mandatory to support at least one of the Rf, Ga or Bea interfaces from the SCEF as described in the present document.

4.3 Northbound API online charging architecture

Northbound API online charging is based on SCEF utilizing Ro interface and application towards the OCS as specified in TS 32.299 [50]. The Ro reference point covers all online charging functionality required for SCEF.

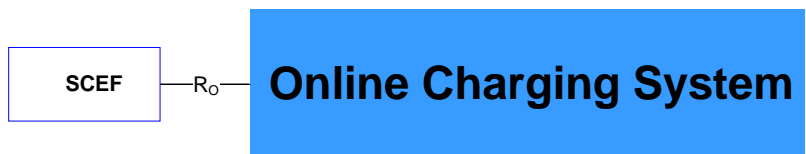

Figure 4.3.1: Northbound API online charging architecture

Details on the interfaces and functions can be found in TS 32.240 [1] for the general architecture components, TS 32.296 [53] for the OCS, and TS 32.299 [50] for the Ro application.

4.4 Northbound API converged charging architecture

The architectural options for Northbound API (including CAPIF) converged charging are depicted in figure 4.4.1 in service-based representation:

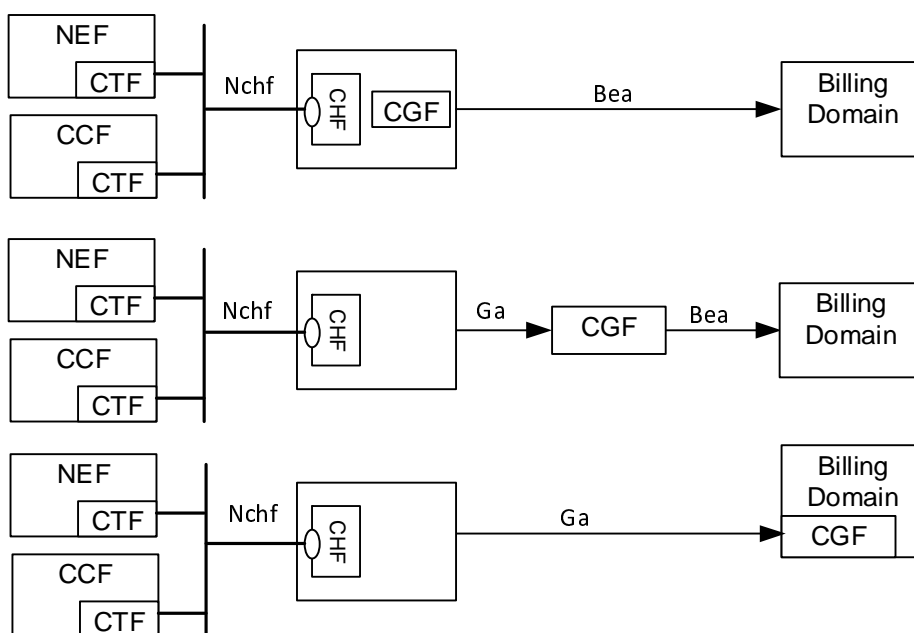

Figure 4.4.1: Northbound API converged charging architecture

Architectural options of figure 4.4.1 apply to any Northbound API converged charging architecture of this clause.

Details on the interfaces and functions can be found in TS 32.240 [1] for the general architecture components, Ga is described in clause 5.2.4 and Bea in clause 5.2.5 of this document, and Nchf is described in TS 32.290 [57].

Figure 4.4.2 depicts the Northbound API converged charging architecture for non-roaming in reference point representation:

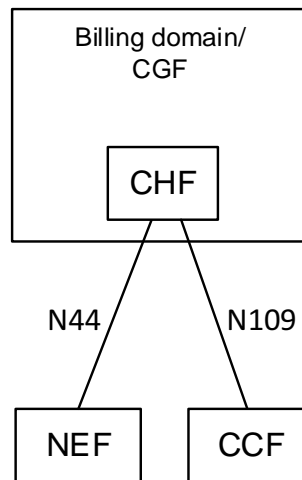

Figure 4.4.2: Northbound API converged charging architecture non-roaming reference point representation

5 Northbound API charging principles and scenarios

5.1 Northbound API charging principles

5.1.0 General

The following are high level charging requirements for northbound API for Exposure Function which are specified in TS 23.682 [243], TS 23.501 [200], and TS23 23.222 [202]:

For northbound API invocation/notification, the SCEF, NEF, or CCF shall collect the following charging information:

- invocations/notifications count of the northbound APIs.
- identification of the SCS/AS or AF and the associated northbound API invocation/notification.
- timestamp of the northbound API invocation/notification.
- northbound API related information, e.g. location.

5.1.1 Northbound API procedures

All procedures that operate across the T8 reference point, as specified in 3GPP TS 23.682 [243] and TS 29.122 [230], are covered, which are the following:

- Monitoring
- Resource management of Background Data Transfer
- Changing the chargeable party at session set up or during the session
- Non-IP Data Delivery
- Device Triggering
- Group Message Delivery
- Reporting of Network Status
- Communication Pattern Parameters Provisioning

- PFD Management
- Enhanced Coverage Restriction Control
- Network Parameter Configuration
- Setting up an AS session with required QoS
- MSISDN-less Mobile Originated SMS

The following clauses 5.2 and 5.3 describe the trigger conditions and simplified message flows for Event Based Charging (IEC/ECUR), with interfaces specified in 3GPP TS 32.299 [50].

The Northbound APIs supported by the NEF via the set of exposed services defined in 3GPP TS 23.502 [201] are covered for converged charging, with the trigger conditions and message flows defined in clause 5.4. All procedures are specified in TS 29.522 [231], which includes the following examples:

- Time synchronization exposure service
- IMS event exposure service
- Monitoring

The Northbound APIs supported by the CAPIF via the set of exposed service APIs defined in 3GPP TS 23.222 [202] are covered, which are the following:

- Service activation: Onboarding the API invoker to the CAPIF, as specified in TS 23.222 [202], clause 8.1;
- Service in-activation: Offboarding the API invoker from the CAPIF, as specified in TS 23.222 [202], clause 8.2.
- Service API publish, as specified in the TS 23.222 [202] clause 8.3
- Service API unpublish, as specified in the TS 23.222 [202] clause 8.4
- Service API retrieve, as specified in the TS 23.222 [202] clause 8.5
- Service API update, as specified in the TS 23.222 [202] clause 8.6
- Discover service APIs, as specified in TS 23.222 [202] Clause 8.7.
- Subscription, un-subscription and notifications for the CAPIF events (e.g. API notification for the Monitoring service API invocation) as specified in the TS 23.222 [202] clause 8.8.
- Revoking subscription of the CAPIF events, as specified in the TS 23.222 [202] clause 8.9.
- Auditing Service API, as specified in TS 23.222 [202] Clause 8.22.
- API Provider domain functions registration, as specified in TS 23.222 [202] Clause 8.28.
- API Provider domain functions deregistration, as specified in TS 23.222 [202] Clause 8.30.

The following clause 5.4 describe the NEF or CCF trigger conditions and simplified message flows for Event Based Charging (IEC/PEC/ECUR), with interface specified in 3GPP TS 32.290 [57].

5.1.2 AI/ML support

As per TS 23.501 [200], clause 5.45, at the time or during the AI/ML operation. E.g., Federated Learning, the AF may request the serving NEF to provide QoS for a list of Ues and may subscribe to QoS Monitoring which may include also Consolidated Data Rate monitoring as described in clause 5.45 and in clause 4.15.6.13 of TS 23.502 [201] for those AF requests for QoS that result in a successful resource allocation. Furthermore, the AF which controls the Multi-member AF Session with required QoS may update the list of UEs and/or update the QoS and/or update the QoS monitoring and/or update the Consolidated Data Rate monitoring, as per TS 23.502 [201], clause 4.15.6.13. These procedures might assist the AF e.g. in order to decide which Ues are appropriate for AI/ML operation a.g. Federated Learning operation.

NEF Northbound APIs converged charging encompasses the NEF Northbound APIs specified to support AI/ML-based services:

- Member UE selection assistance functionality for application operation;
- Planned Data Transfer with QoS (PDTQ) requirements;
- Multi-member AF session with required QoS.

For the Multi-member AF session with required QoS, the list of UEs and Consolidated Data Rate are added in order to fulfil AI/ML service requests.

5.2 Northbound API offline charging scenarios

5.2.1 Basic principles

If charging is supported by an SCEF, it shall be able to collect charging information per T8 transaction.

The SCS/AS is identified by the SCS Identifier, which T8 transaction between SCEF and SCS/AS can be determined by a T8 Long Term Transaction Reference ID (TLTRI). The Identifiers are stored on both the SCEF and the SCS/AS for the duration of the transaction.

The following chargeable events are defined for SCEF charging for all Northbound APIs:

- Northbound API invocation/ notification per T8 transaction.
- Expiry of an operator configured time limit per T8 transaction.
- Expiry of an operator configured Northbound API invocation limit per T8 transaction.

Management intervention may also force trigger a chargeable event.

The subscriber is the API invoker (e.g. SCS, AS) of the Northbound APIs.

5.2.2 Rf message flows

5.2.2.1 Triggers for charging events from SCEF

When a charging event is reported to the CDF, it includes the details such as SCEF address, charging information with corresponding charging events to the CDF.

The trigger conditions specified in Table 5.2.2.1.1 are applicable for charging information collection.

Table 5.2.2.1.1: Triggers for Charging Data Request from SCEF

Message	Triggering conditions
Charging Data Request[Event]	T8 transaction creation via HTTP POST
	T8 transaction update via HTTP PATCH message, HTTP PUT message received by SCEF
	T8 transaction termination via HTTP DELETE

5.2.3 CDR generation

5.2.3.1 Introduction

For the exposure functions SCEF, an exposure function API CDR is generated for subsequent transfer to the Charging Gateway Function (CGF).

The following clauses describe the trigger conditions for these exposure function API CDRs creation, update and closure.

5.2.3.2 Triggers for EA-SCE-CDR creation and closure

5.2.3.2.1 Triggers for EA-SCE-CDR generation

A EA-SCE-CDR is used to collect charging information related to API invocation/notification offline charging from the SCEF.

A single EA-SCE-CDR shall be generated for each event when the API invocation or notification is encountered.

5.2.4 Ga record transfer flows

Details of the Ga protocol application are specified in TS 32.295 [54].

5.2.5 Bea CDR file transfer

Details of the Bea protocol application are specified in TS 32.297 [52].

5.3 Northbound API online charging scenarios

5.3.1 Basic principles

5.3.1.1 General

Northbound API online charging is performed by the SCEF using the common Ro based Credit-Control application specified in TS 32.299 [50]. In order to provide the data required for the management activities outlined in TS 32.240 [1], the SCEF shall be able to perform online charging for the following:

- Charging data related to northbound API invocation;
- Charging data related to northbound API notification.

Event based online charging IEC and ECUR are applicable scenarios for the SCEF.

5.3.2 Ro message flows

5.3.2.1 Event Based Charging

This clause contains message flows for the different operation models IEC and ECUR, when the one-time API invocation is per T8 interaction is activated. e.g. Enhanced Coverage Restriction Control API, MSISDN-less Mobile Originated SMS API.

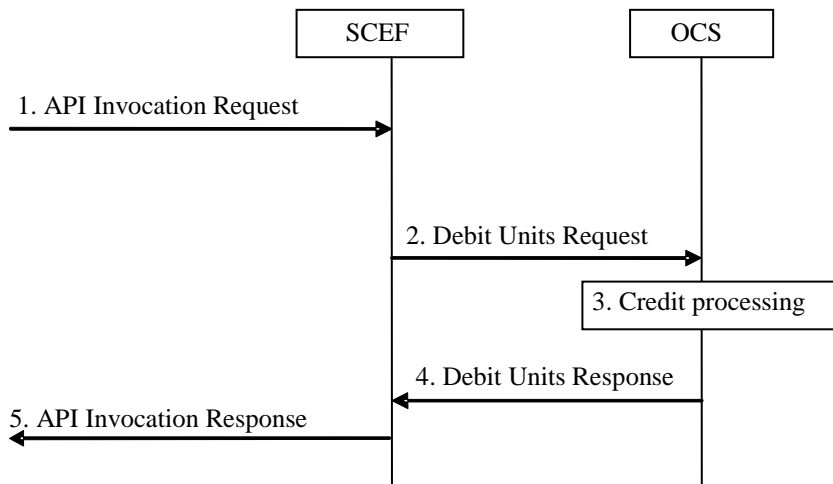

Figure 5.3.2.1.1: Online charging in API Invocation for IEC

- 1) SCEF receives an API invocation Request.
- 2) The SCEF triggers a Debit Units Request message to the OCS.
- 3) The OCS performs the appropriate credit processing based on the received request.
- 4) The OCS responds with a Debit Units Response message to the SCEF.
- 5) If authorized, the SCEF continues the API invocation processing and send out the API Invocation Response.

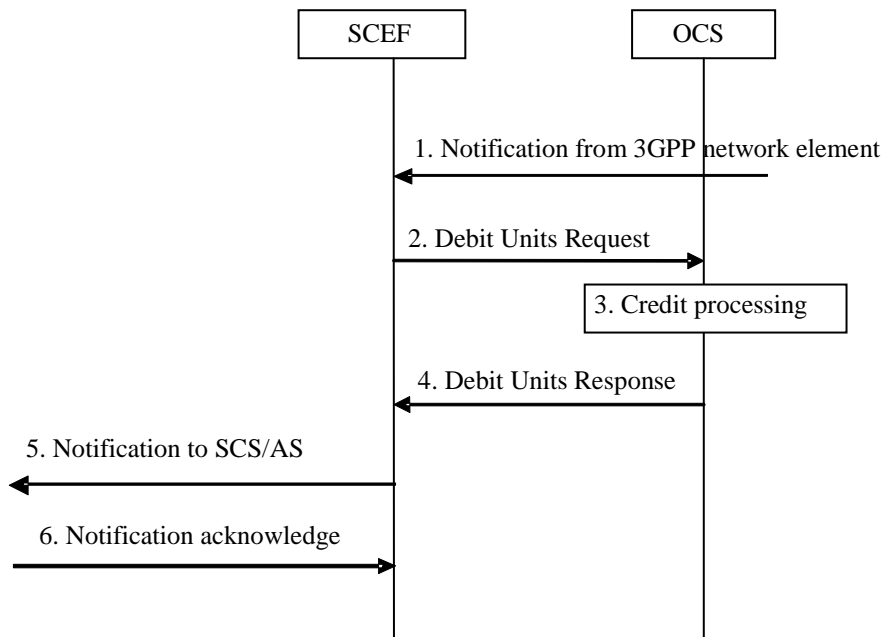

Figure 5.3.2.1.2: Online charging in API Notification for IEC

- 1) SCEF receives a notification from 3GPP network element.
- 2) The SCEF triggers a Debit Units Request message to the OCS.
- 3) The OCS performs the appropriate credit processing based on the received request.
- 4) The OCS responds with a Debit Units Response message to the SCEF.
- 5) SCEF sends the notification to SCS/AS.
- 6) SCEF receives acknowledgement for the notification.

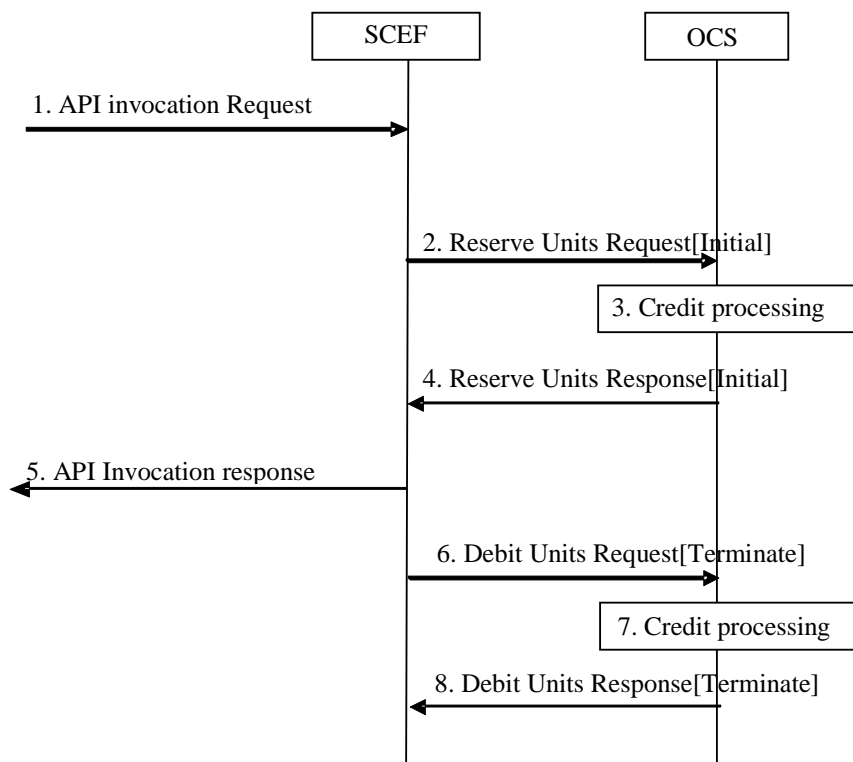

Figure 5.3.2.1.3: Online charging in API Invocation for ECUR

- 1) SCEF receives an API invocation Request.
- 2) The SCEF triggers a Reserve Units Request [Initial] message to the OCS.
- 3) The OCS performs the appropriate credit processing based on the received request.
- 4) The OCS responds with a Reserve Units Response message to the SCEF.
- 5) If authorized, the SCEF continues the API invocation processing and send out the API Invocation Response.
- 6) The SCEF triggers a Debit Units Request [Terminate] message to the OCS reporting the successful event transaction.
- 7) The OCS performs the appropriate credit processing based on the received request.
- 8) The OCS responds with a Debit Units Response message to the SCEF.

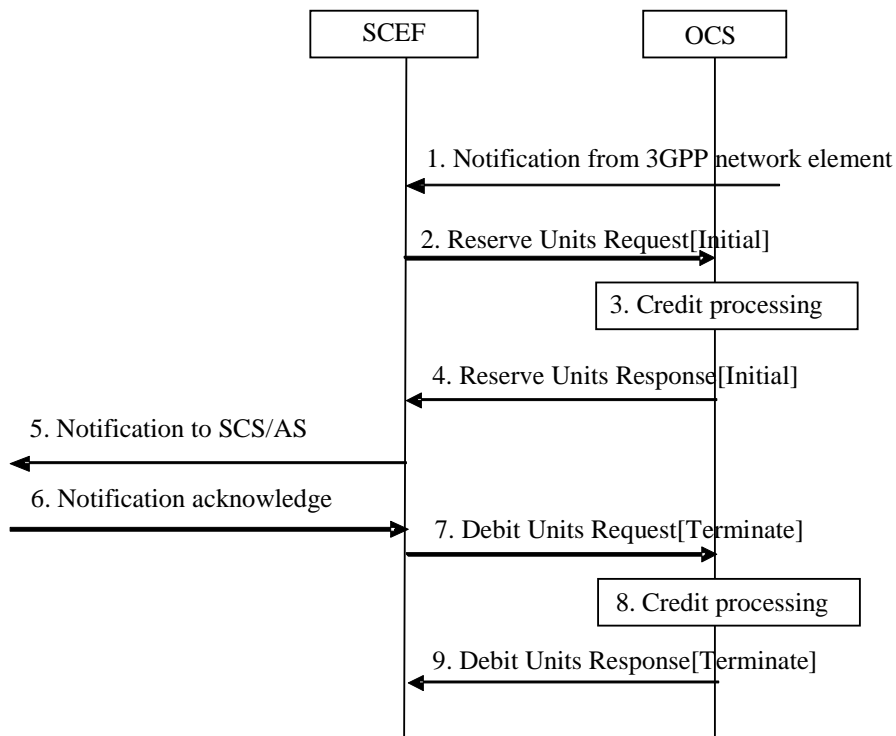

Figure 5.3.2.1.4: Online charging in API Notification for ECUR

- 1) SCEF receives a notification from 3GPP network entities.
- 2) The SCEF triggers a Reserve Units Request [Initial] message to the OCS.
- 3) The OCS performs the appropriate credit processing based on the received request.
- 4) The OCS responds with a Reserve Units Response message to the SCEF.
- 5) SCEF sends the notification to SCS/AS.
- 6) SCEF receives acknowledgement for the notification.
- 7) The SCEF triggers a Debit Units Request [Terminate] message to the OCS reporting the successful event transaction.
- 8) The OCS performs the appropriate credit processing based on the received request.
- 9) The OCS responds with a Debit Units Response message to the SCEF.

5.4 Northbound API converged online and offline charging scenarios

5.4.1 Basic principles

5.4.1.1 General

Converged charging may be performed by the NEF and CCF interacting with CHF using Nchf specified in TS 32.290 [57] and TS 32.291 [58]. In order to provide the data required for the management activities outlined in TS 32.240 [1] (Credit-Control, accounting, billing, statistics etc.), the NEF and CCF shall be able to perform converged charging for the northbound API access of service API operations.

The NEF and CCF shall be able to perform convergent charging by interacting with CHF, for charging data related to Northbound API access. The Charging Data Request and Charging Data Response are exchanged between the NEF and the CHF, and also between CCF and CHF, based on PEC, either IEC or ECUR scenarios specified in TS 32.290 [57]. The Charging Data Request can either be issued by the NEF or the CCF towards the CHF when certain conditions (chargeable events) are met.

Converged charging uses centralized or decentralized unit determination and centralized rating scenarios for event based convergent charging specified in TS 32.290 [57].

The contents and purpose of each charging event that triggers interaction with CHF, as well as the chargeable events that trigger them, are described in the following clauses.

A detailed formal description of the converged charging parameters defined in the present document is to be found in TS 32.291 [58].

A detailed formal description of the CDR parameters defined in the present document is to be found in TS 32.298 [51].

The selection of the CHF can be configured either in the NEF or CCF but may also rely on NRF.

5.4.1.2 Applicable Triggers in the NEF and CCF

5.4.1.2.1 General

When a charging event is issued towards the CHF, it includes details such as Subscriber identifier (e.g. identifier of the AF).

Each trigger condition (i.e. chargeable event) defined either for the NEF or CCF converged charging functionality, is specified with the associated behaviour when they are met.

Table 5.4.1.2.1.1 summarizes the set of default trigger conditions and their category which shall be supported either by the NEF or the CCF when charging is active for the corresponding either NEF or CCF functionality. For "immediate report" category, the table also provides the corresponding Charging Data Request message either sent from NEF or the CCF towards the CHF.

Table 5.4.1.2.1.1: Default Trigger conditions in NEF

Trigger Conditions	Trigger level	Default category	CHF allowed to change category	CHF allowed to enable and disable	Message when "immediate reporting" category
API Invocation	-	Immediate	Not Applicable	Not Applicable	IEC: Charging Data Request [Event] ECUR: Charging Data Request [Initial]
API Invocation Response	-	Immediate	Not Applicable	Not Applicable	PEC: Charging Data Request [Event] ECUR: Charging Data Request [Termination]
API Notification	-	Immediate	Not Applicable	Not Applicable	IEC: Charging Data Request [Event] ECUR: Charging Data Request [Initial]
API Notification to NF	-	Immediate	Not Applicable	Not Applicable	PEC: Charging Data Request [Event]
API Notification acknowledgement	-	Immediate	Not Applicable	Not Applicable	ECUR: Charging Data Request [Termination]

5.4.2 Message flows

5.4.2.1 Introduction

The different scenarios below focus on the different messages from/to the NEF, from/to the CCF and corresponding interaction with the CHF, based on scenarios specified in TS 23.222 [202].

5.4.2.2 API Invocation - IEC

Figure 5.4.2.2.1 describes the scenario where there is an API invocation request at the NEF for IEC mode

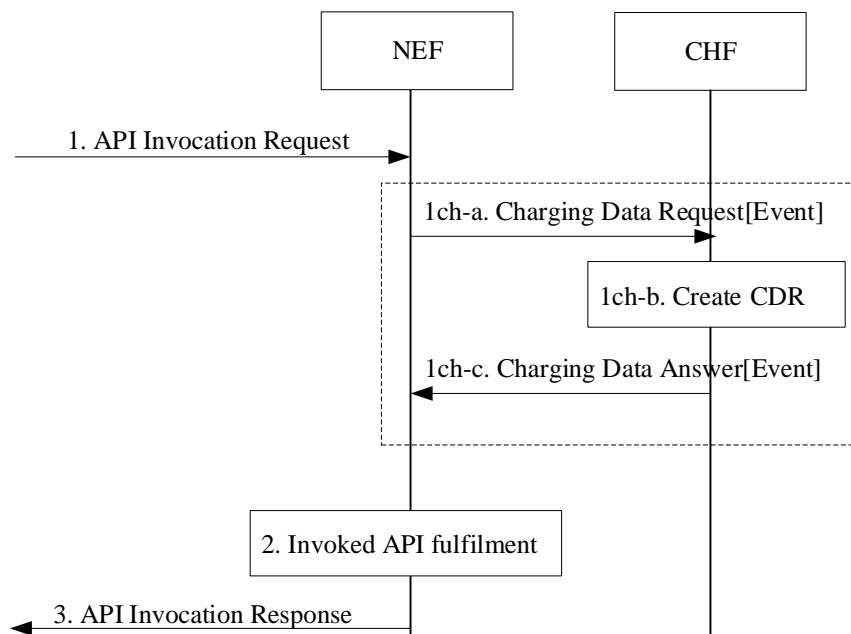

Figure 5.4.2.2.1: API Invocation Request to NEF using IEC

1. NEF receives an API invocation Request from an AF.
- 1ch-a. The NEF sends Charging Data Request [Event] to CHF for the received API Invocation.
- 1ch-b. The CHF creates a CDR for this API Invocation.
- 1ch-c. The CHF acknowledges and grants authorization by sending Charging Data Response [Event] to the NEF.
2. NEF performs the actions needed to fulfil the API invoked.
3. If authorized, the NEF continues the API invocation processing and sends the API Invocation Response.

5.4.2.3 API Invocation - ECUR

Figure 5.4.2.3.1 describes the scenario where there is an API invocation request at the NEF for ECUR mode.

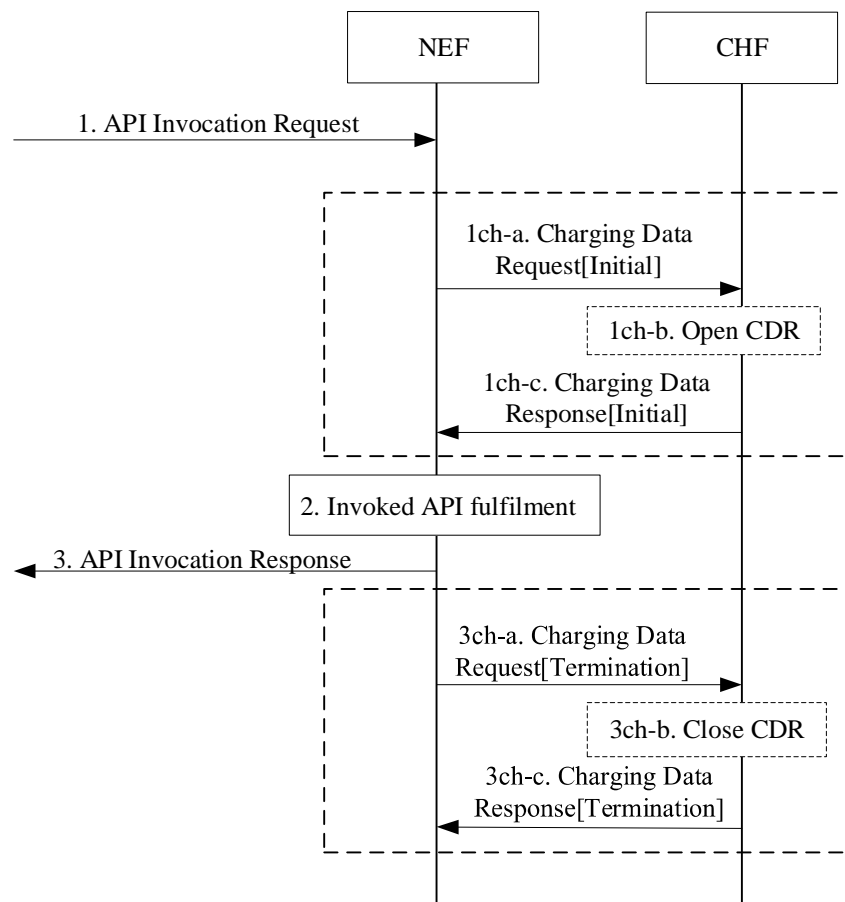

Figure 5.4.2.3.1: API Invocation Request to NEF using ECUR

1. NEF receives an API invocation Request from an AF.
- 1ch-a. The NEF sends Charging Data Request [Initial] to CHF for the received API Invocation.
- 1ch-b. The CHF opens CDR for this API Invocation.
- 1ch-c. The CHF acknowledges by sending Charging Data Response [Initial] to the NEF.
2. NEF performs the actions needed to fulfil the API invoked.
3. If authorized, the NEF continues the API invocation processing and sends the API Invocation Response.
- 3ch-a. The NEF sends Charging Data Request [Termination] to the CHF for terminating the charging associated with the API Invocation.
- 3ch-b. The CHF closes the CDR for this API Invocation.
- 3ch-c. The CHF acknowledges by sending Charging Data Response [Termination] to the NEF.

5.4.2.4 API Notification - IEC

Figure 5.4.2.4.1 describes the scenario where an API Notification is delivered from the NEF for IEC mode

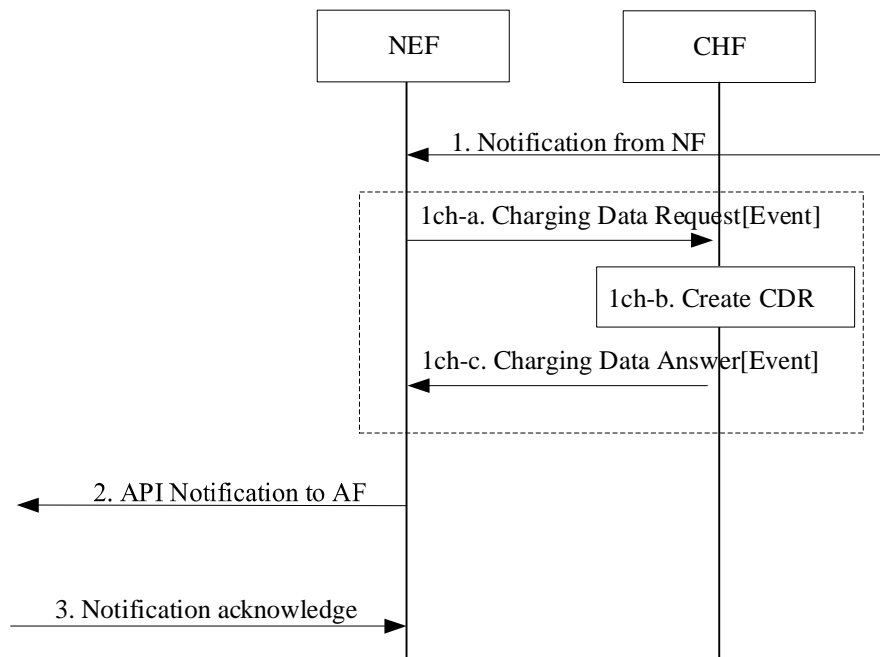

Figure 5.4.2.4.1 API Notification from NEF using IEC

1. The NEF receives a notification from an NF.

1ch-a. The NEF sends Charging Data Request [Event] to CHF for the Notification.

1ch-b. The CHF creates a CDR for this Notification.

1ch-c. The CHF acknowledges and grant authorization by sending Charging Data Response [Event] to the NEF.

2. The NEF sends the notification to AF.

3. The NEF receives acknowledgement for the notification.

5.4.2.5 API event Notification - ECUR

Figure 5.4.2.5.1 describes the scenario where an API event Notification is delivered from the NEF for ECUR mode.

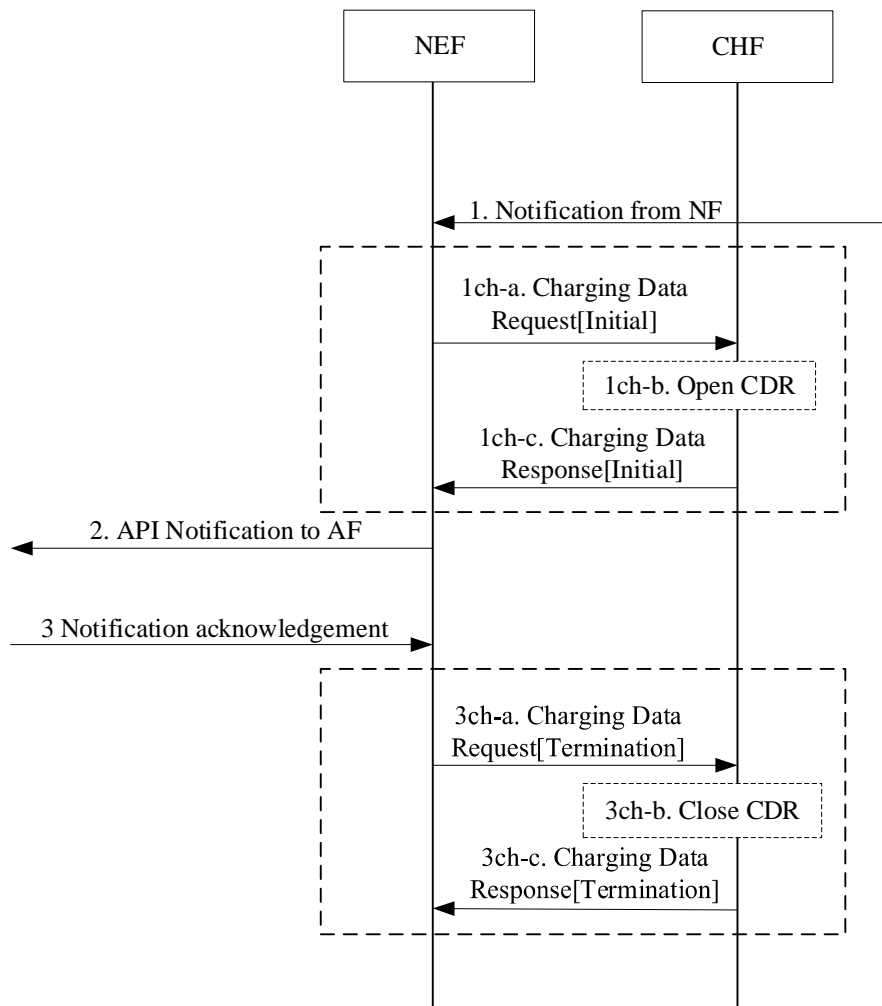

Figure 5.4.2.4.1: API Notification from NEF using ECUR

- 1. The NEF receives a notification from an NF.
- 1ch-a. The NEF sends Charging Data Request [Initial] to CHF for the Notification.
- 1ch-b. The CHF opens CDR for this API Notification.
- 1ch-c. The CHF acknowledges by sending Charging Data Response [Initial] to the NEF.
- 2. The NEF sends the notification to AF.
- 3. The NEF receives acknowledgement for the notification.
- 3ch-a. The NEF sends Charging Data Request [Termination] to the CHF for terminating the charging associated with the API event Notification.
- 3ch-b. The CHF closes the CDR for this API Notification.
- 3ch-c. The CHF acknowledges by sending Charging Data Response [Termination] to the NEF.

5.4.2.6 API Invocation - PEC

Figure 5.4.2.6.1 describes the scenario where there is an API invocation request at the NEF for PEC mode

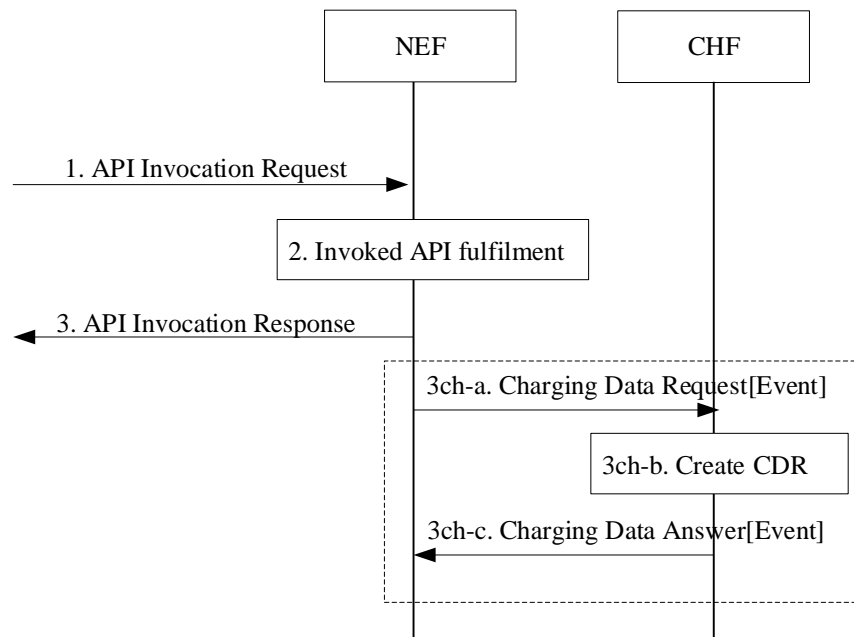

Figure 5.4.2.6.1: API Invocation Request to NEF using PEC

1. NEF receives an API invocation Request from an AF.
2. NEF performs the actions needed to fulfil the API invoked.
3. If authorized, the NEF continues the API invocation processing and sends the API Invocation Response.
- 3ch-a. The NEF sends Charging Data Request [Event] to CHF for the received API Invocation.
- 3ch-b. The CHF creates a CDR for this API Invocation.
- 3ch-c. The CHF acknowledges by sending Charging Data Response [Event] to the NEF.

5.4.2.7 API Notification - PEC

Figure 5.4.2.7.1 describes the scenario where an API Notification is delivered from the NEF for PEC mode

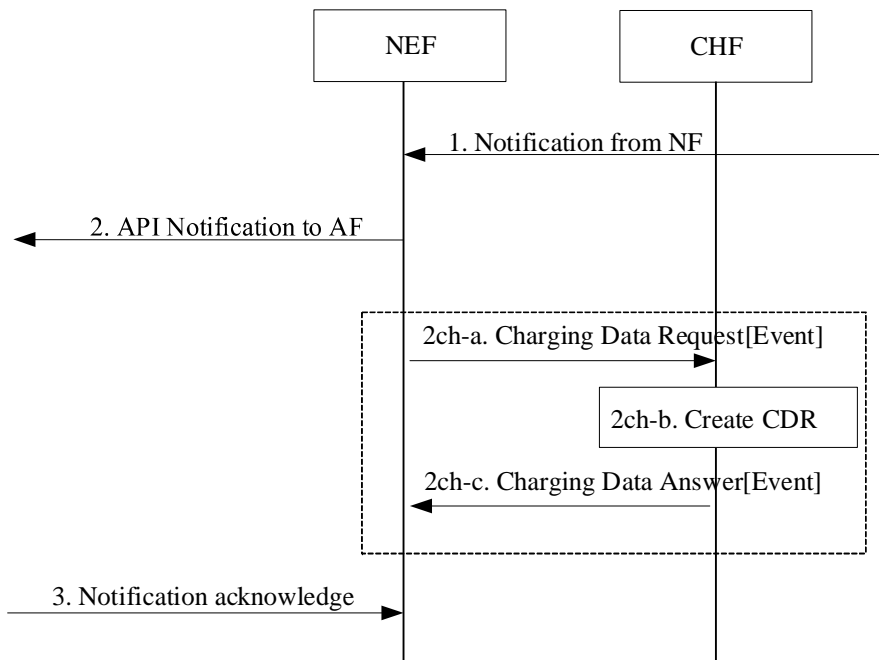

Figure 5.4.2.7.1 API Notification from NEF using PEC

1. The NEF receives a notification from an NF.
2. The NEF sends the notification to AF.
- 2ch-a. The NEF sends Charging Data Request [Event] to CHF for the Notification.
- 2ch-b. The CHF creates a CDR for this Notification.
- 2ch-c. The CHF acknowledges by sending Charging Data Response [Event] to the NEF.
3. The NEF receives acknowledgement for the notification.

5.4.2.8 CAPIF Invoker and Provider Request (PEC)

Figure 5.4.2.8-1 describes the scenario where an API Invoker Management Request is delivered from the CCF for PEC mode.

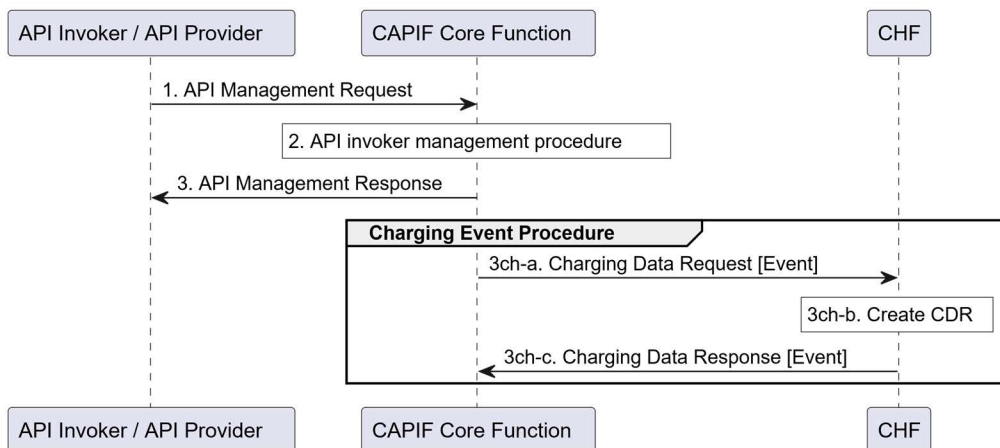

Figure 5.4.2.8-1: CAPIF invoker and Provider request from CCF using PEC

1. The CAPIF supports management of API invoker/API Provider with CAPIF_API_invoker_management API, including onboard/offboard API invoker, as defined in TS 23.222 [2] clause 10.5, and CAPIF_Publish_Service_API, including publish/unpublish/get/update service API, as defined in clause 10.3 in TS 23.222 [2]. The API invoker/API Provider triggers an API invoker/API Provider request to the CAPIF core function.
2. CAPIF core function performs API invoker/API Provider management procedure which can include onboarding approval (enrolment of the API invoker to be a recognized as user of the CAPIF) and cancelling the API invoker enrolment from CAPIF, or service API management procedure which includes storing /removing /retrieving/ updating API information.
3. The CAPIF sends either an onboarding/offboarding API invoker management response, or service API management response.
 - 3ch-a. CAPIF core function generates charging data related to the API invoker/API Provider management and sends the request for the CHF to store related charging data for CDR generation purpose.
 - 3ch-b. CHF stores received information and creates a CDR related to the API invokers/API Providers.
 - 3ch-c. CHF informs the CAPIF core function on the result of the request.

5.4.3 CDR generation

5.4.3.1 Introduction

The CHF CDRs for NEF charging are generated by the CHF to collect charging information that they subsequently transfer to the Charging Gateway Function (CGF).

The following clauses describe in details the conditions for generating, opening and closing the CHF CDR, which shall be supported by the CHF.

5.4.3.2 Triggers for CHF CDR

5.4.3.2.1 General

A Northbound API charging CHF CDR is used to collect charging information related to northbound API invocation and notifications chargeable events for PEC, IEC and ECUR.

5.4.3.2.2 Triggers for CHF CDR generation

A CHF CDR is generated by the CHF for each received Charging Data Request[Event].

5.4.3.2.3 Triggers for CHF CDR opening

A CHF CDR shall be opened when the CHF receives Charging Data Request[Initial].

5.4.3.2.4 Triggers for CHF CDR closure

The CHF CDR shall be closed when the CHF receives Charging Data Request[Termination].

5.4.4 Ga record transfer flows

Details of the Ga protocol application are specified in TS 32.295 [6].

5.4.5 Bea CDR file transfer

Details of the Bea protocol application are specified in TS 32.297 [5].

6. Definition of charging information

6.1 Data description for Northbound API offline charging

6.1.1 Rf message contents

6.1.1.1 General

The Exposure Function API offline charging uses the Charging Data Transfer messages Charging Data Request and Charging Data Response defined in TS 32.299 [50].

The Charging Data Request can be of type event and includes all charging information. The Charging Data Response is an acknowledgement of the Charging Data Request.

Table 6.1.1.1.1 describes the use of these messages for offline charging.

Table 6.1.1.1.1: Offline charging messages reference table

Message	Source	Destination
Charging Data Request	SCEF	CDF
Charging Data Response	CDF	SCEF

The following clauses describe the different fields used in the Charging Data messages and the category in the tables is used according to the charging data configuration defined in clause 5.4 of TS 32.240 [1].

6.1.1.2 Charging data request message

Table 6.1.1.2.1 illustrates the basic structure of a Charging Data Request message from the SCEF as used for Exposure Function API offline charging.

Table 6.1.1.2.1: Charging Data Request message contents

Information Element	Category	Description
Session Identifier	M	Described in TS 32.299 [50]
Originator Host	M	Described in TS 32.299 [50]
Originator Domain	M	Described in TS 32.299 [50]
Destination Domain	M	Described in TS 32.299 [50]
Operation Type	M	Described in TS 32.299 [50]
Operation Number	M	Described in TS 32.299 [50]
Operation Identifier	O _C	Described in TS 32.299 [50]
User Name	O _C	Described in TS 32.299 [50]
Destination Host	O _C	Described in TS 32.299 [50]
Operation Interval	O _C	Described in TS 32.299 [50]
Origination State	O _C	Described in TS 32.299 [50]
Origination Timestamp	O _C	Described in TS 32.299 [50]
Proxy Information	O _C	Described in TS 32.299 [50]
Route Information	O _C	Described in TS 32.299 [50]
Operation Token	O _M	This field identifies the Exposure Function API domain service.
Service Information	O _M	This field holds the Exposure Function API specific information described in clause 6.3.

NOTE: Detailed descriptions of the information elements are provided in TS 32.299 [50].

6.1.1.3 Charging data response message

Table 6.1.1.3.1 illustrates the basic structure of a Charging Data Response message as used for Exposure Function API offline charging.

Table 6.1.1.3.1: Charging Data Response message contents

Information Element	Category	Description
Session Identifier	M	Described in TS 32.299 [50]
Operation Result	M	Described in TS 32.299 [50]
Originator Host	M	Described in TS 32.299 [50]
Originator Domain	M	Described in TS 32.299 [50]
Operation Type	M	Described in TS 32.299 [50]
Operation Number	O _C	Described in TS 32.299 [50]
Operation Identifier	O _C	Described in TS 32.299 [50]
Operation Interval	O _C	Described in TS 32.299 [50]
Error Reporting Host	O _C	Described in TS 32.299 [50]
Origination State	O _C	Described in TS 32.299 [50]
Origination Timestamp	O _C	Described in TS 32.299 [50]
Proxy Information	O _C	Described in TS 32.299 [50]

NOTE: Detailed descriptions of the information elements are provided in TS 32.299 [50].

6.1.2 Ga message contents

Refer to clause 5.2.4 for further information.

6.1.3 CDR description on the Bea interface

6.1.3.1 General

The following standard CDRs content and format are considered:

- EA-SCE-CDR generated for exposure function API from the SCEF.

For each of the CDR types, a parameter table, which gives a short description of the parameters, is provided. The category in the tables is used according to the charging data configuration defined in clause 5.4 of TS 32.240 [1]. Full definitions of the CDR parameters, sorted by the name in alphabetical order, are provided in TS 32.298 [51].

6.1.3.2 Exposure Function API charging data (EA-SCE-CDR)

Exposure function API record shall be produced for each API invocation to the SCEF. The fields in the record are specified in table 6.1.3.2.1.

Table 6.1.3.2.1: Exposure function API from SCEF charging data (EA-SCE-CDR)

Field	Category	Description
Record Type	M	SCEF exposure function API record.
Retransmission	O _c	This parameter, when present, indicates that information from retransmitted Accounting Requests has been used in this CDR.
Service Context Id	O _M	This parameter indicates the CDR is applicable to exposure function API service.
Node Id	O _{M,M}	Name of the recording entity.
SCEF ID	M	This parameter holds the identity of the SCEF used for this API invocation.
SCEF Address	O _c	This parameter holds the IP address of SCEF.
API Identifier	M	This field holds the identity of API for each API invocation.
TLTRI	O _c	This field holds the T8 Long Term Transaction Reference ID.
SCS/AS Address	M	This field holds the IP address of SCS/AS
Event Timestamp	M	This field holds the time stamp of the event reported.
API Invocation Timestamp		This field holds the time stamp when the API invocation request is submitted to the SCEF from SCS/AS.
API Direction	O _c	This field holds the direction to indicate the API invocation or API notification.
API Network Service Node	O _c	This field holds the identifier of the network element (e.g. SGSN, RCAF) that triggers the API notification as defined in TS 23.682 [243].
API Content	O _c	This field holds the API content (e.g. location, Monitoring Type) used in the T8 transaction for the API invocation request, if available.
API Size	O _c	This field holds the size of API payload.
API Result Code	O _c	This field holds the result of API Invocation.
External Identifier	O _c	This field holds the external identifier identifying the served party associated to the IMSI or MSISDN or External Group ID, if available.
Local Record Sequence Number	O _M	Consecutive record number created by this node. The number is allocated sequentially including all CDR types.
Record Extensions	O _c	A set of network operator/manufacture specific extensions to the record. Conditioned upon the existence of an extension.

6.2 Data description for Northbound API online charging

6.2.1 Ro message contents

6.2.1.0 Introduction

The SCEF generates Debit / Reserve Units information that can be transferred from the CTF to the OCF. For this purpose, SCEF online charging utilizes the *Debit Units and Reserve Units* procedure that is specified in the 3GPP Debit / Reserve Units operation in TS 32.299 [50].

6.2.1.1 Summary of message formats

Table 6.2.1.1.1 describes the use of these messages for SCEF online charging.

Table 6.2.1.1.1: SCEF online charging messages contents

Command-Name	Source	Destination
Debit / Reserve Units Request	SCEF	OCF
Debit / Reserve Units Response	OCF	SCEF

This clause describes the different fields used in the Debit / Reserve Units Request and Debit / Reserve Units Responses messages and the category in the tables are used according to the charging data configuration defined in clause 5.4 of TS 32.240 [1].

Detailed descriptions of the fields are provided in TS 32.299 [50].

6.2.1.2 Structure for the Credit-Control message formats

6.2.1.2.1 Debit/Reserve Units Request message

Table 6.2.1.2.1.1 illustrates the basic structure of a *Debit / Reserve Units Request* message from SCEF as used for exposure function API online charging.

Table 6.2.1.2.1.1: Debit / Reserve Units Request message contents for exposure function API

Information Element	Category	Description
Session Identifier	M	Described in TS 32.299 [50]
Originator Host	M	Described in TS 32.299 [50]
Originator Domain	M	Described in TS 32.299 [50]
Destination Domain	M	Described in TS 32.299 [50]
Operation Identifier	M	Described in TS 32.299 [50]
Operation Token	M	Described in TS 32.299 [50]
Operation Type	M	Described in TS 32.299 [50]
Operation Number	M	Described in TS 32.299 [50]
Destination Host	O _C	Described in TS 32.299 [50]
User Name	O _C	Described in TS 32.299 [50]
Origination State	O _C	Described in TS 32.299 [50]
Origination Timestamp	O _C	Described in TS 32.299 [50]
Subscriber Identifier	O _M	This field contains the identification of the subscriber (i.e. SCS/AS Identifier) that uses the requested service.
Termination Cause	O _C	Described in TS 32.299 [50]
Requested-Action	O _C	This field contains the requested action, used for IEC only.
Multiple Operation	O _M	This field indicate the occurrence of multiple operations.
Multiple Unit Operation	O _C	This field contains the parameter for the quota management.
Proxy Information	O _C	This field contains the parameter of the proxy.
Route Information	O _C	This field contains the parameter of the route.
Service Information	O _M	This field holds the SCEF specific parameter and is described in clause 6.3.

6.2.1.2.2 Debit / Reserve Units Response message

Table 6.2.1.2.2.1 illustrates the basic structure of a *Debit / Reserve Units Response* message as used for SCEF charging.

This message is always used by the OCS as specified below, independent of the receiving SCEF and the operation type that is being replied to.

Table 6.2.1.2.2.1: Debit / Reserve Units Response message contents for exposure function API

Information Element	Category	Description
Session Identifier	M	Described in TS 32.299 [50]
Operation Result	M	Described in TS 32.299 [50]
Originator Host	M	Described in TS 32.299 [50]
Originator Domain	M	Described in TS 32.299 [50]
Operation Identifier	M	Described in TS 32.299 [50]
Operation Type	M	Described in TS 32.299 [50]
Operation Number	M	Described in TS 32.299 [50]
Multiple Unit Operation	O _C	Described in TS 32.299 [50]
Operation Failure Action	O _C	Described in TS 32.299 [50]
Operation Event Failure Action	O _C	Described in TS 32.299 [50]
Redirection Host	O _C	Described in TS 32.299 [50]
Redirection Host Usage	O _C	Described in TS 32.299 [50]
Route Information	O _C	Described in TS 32.299 [50]
Failed parameter	O _C	Described in TS 32.299 [50]
Service Information	O _C	Described in TS 32.299 [50]

6.2a Data description for NEF converged charging

6.2a.1 Message contents

6.2a.1.1 General

The Charging Data Request and Charging Data Response are specified in TS 32.290 [57] and include charging information. The Charging Data Request can be of type [Event, Initial, Termination].

Table 6.2a.1.1.1 describes the use of these messages for converged charging.

Table 6.2a.1.1.1: Converged charging messages reference table

Message	Source	Destination
Charging Data Request	NEF	CHF
Charging Data Response	CHF	NEF

The following clauses describe the different fields used in the Charging Data messages and the category in the tables is used according to the charging data configuration defined in clause 5.4 of TS 32.240 [2].

6.2a.1.2 Structure for the converged charging message formats

6.2a.1.2.1 Charging Data Request message

Table 6.2a.1.2.1.1 illustrates the basic structure of a Charging Data Request message as used for NEF and CCF converged charging.

Table 6.2a.1.2.1.1: Charging Data Request message contents

Information Element	Category	Description
Session Identifier	O _C	Described in TS 32.290 [57]
Subscriber Identifier	O _M	Described in TS 32.290 [57] and may hold the identifier of the AF as an alternative to tenant identifier.
Tenant Identifier	O _C	Described in TS 32.290 [57] and may hold the identifier of the AF, API Invoker, or API Provider.
NF Consumer Identification	M	Described in TS 32.290 [57]
NF Functionality	M	Described in TS 32.290 [57].
NF Name	O _C	Described in TS 32.290 [57].
NF Address	O _C	Described in TS 32.290 [57].
NF PLMN ID	O _C	Described in TS 32.290 [57].
Charging Identifier	O _M	Described in TS 32.290 [57]
Invocation Timestamp	M	Described in TS 32.290 [57]
Invocation Sequence Number	M	Described in TS 32.290 [57]
One-time Event	O _C	Described in TS 32.290 [57].
One-time Event Type	O _C	Described in TS 32.290 [57].
Supported Features	O _C	Described in TS 32.290 [57]
Service Specification Information	O _C	Described in TS 32.290 [57]
Multiple Unit Usage	O _C	This field contains the parameters for the quota management request and/or usage reporting.
Rating Group	M	Described in TS 32.290 [57]
Requested Unit	O _C	Described in TS 32.290 [57]
Used Unit Container	O _C	Described in TS 32.290 [57]
NEF API Charging Information	O _M	This field holds the NEF API specific information described in clause 6.3.1.4

6.2a.1.2.2 Charging Data Response message

Table 6.2a.1.2.2.1 illustrates the basic structure of a Charging Data Response message as used for NEF and CCF converged charging.

Table 6.2a.1.2.2.1: Charging Data Response message content

Information Element	Category	Description
Session Identifier	O _C	Described in TS 32.290 [57]
Invocation Timestamp	M	Described in TS 32.290 [57]
Invocation Result	O _C	Described in TS 32.290 [57]
Invocation Result Code	O _C	Described in TS 32.290 [57]
Failed parameter	O _C	Described in TS 32.290 [57]
Failure Handling	O _C	Described in TS 32.290 [57]
Invocation Sequence Number	M	Described in TS 32.290 [57]
Session Failover	O _C	Described in TS 32.290 [57]
Supported Features	O _C	Described in TS 32.290 [57]
Multiple Unit Information	O _C	This field holds the parameters for the quota management information.
Result Code	O _C	Described in TS 32.290 [57]
Rating Group	O _M	Described in TS 32.290 [57]
Granted Unit	O _C	Described in TS 32.290 [57]
Validity Time	O _C	Described in TS 32.290 [57]

6.2a.2 G_a message contents

Refer to clause 5.4.4.

6.2a.3 CDR description on the B_{ea} interface

6.2a.3.1 General

This clause describes the CDR content and format generated for NEF converged charging.

The following tables provide a brief description of each CDR parameter. The category in the tables is used according to the charging data configuration defined in clause 5.4 of TS 32.240 [2]. Full definitions of the CDR parameters, sorted by the name in alphabetical order, are provided in TS 32.298 [3].

6.2a.3.2 NEF charging CHF CDR data

If enabled, CHF CDRs for NEF charging shall be produced for NEF chargeable events.

The fields of NEF charging CHF CDR are specified in table 6.2a.3.2.1.

Table 6.2a.3.2.1: NEF charging CHF record data

Field	Category	Description
Record Type	M	Described in TS 32.298 [3]
Recording Network Function ID	O _M	Described in TS 32.298 [3]
Subscriber Identifier	O _M	This field contains the identification of the API user (e.g. SCS Identifier), or the identifier of the AF as an alternative to tenant identifier
Tenant Identifier	O _C	This field contains the identification of the Tenant, and may hold the Application Identifier
NF Consumer Information	O _M	This field holds the information of the NEF that used the charging service
List of Multiple Unit Usage	O _M	Described in TS 32.298 [3]
Record Opening Time	O _C	Described in TS 32.298 [3]
Duration	M	Described in TS 32.298 [3]
Record Sequence Number	O _C	Described in TS 32.298 [3]
Cause for Record Closing	M	Described in TS 32.298 [3]
Local Record Sequence Number	O _M	Described in TS 32.298 [3]
Record Extensions	O _C	Described in TS 32.298 [3]
NEF API Charging Information	O _M	This field holds the NEF specific information defined in clause 6.3.1.4

6.3 Northbound API charging specific parameters

6.3.1 Definition of Northbound API charging information

6.3.1.1 Exposure Function API charging information assignment for Service Information

The components in the Service Information that are used for Exposure Function API charging can be found in table 6.3.1.1.1.

Table 6.3.1.1.1: Service Information used for Exposure Function API charging

Information Element	Category	Description
Service Information	O _M	This is a structured field and holds the 3GPP specific parameter as defined in TS 32.299 [50].
Subscriber Identifier	O _M	This field contains the identification of the user (i.e. SCS Identifier).
IMS Information	O _M	This is a structured field and holds IMS specific parameters. The complete structure is defined in TS 32.260 [20].
Node Functionality	O _c	This IE Identifies the type of record.
Exposure Function API Information	O _M	This is a structured field and holds the Exposure Function API specific parameters. The details are defined in clause 6.3.1.2.

6.3.1.2 Definition of the Exposure Function API Information

Exposure Function API specific charging information is provided within the Exposure Function API Information. The fields of the Exposure Function API Information are indicated with the SCEF from which the information is sent.

The detailed structure of the Exposure Function API Information can be found in table 6.3.1.2.1.

Table 6.3.1.2.1: Structure of the Exposure Function API Information

Information Element	Category	Description
Supported Features	O _c	This field holds the list of features supported by the SCEF, CDF or OCF as defined in clause 6.3.1.3.
External Identifier	O _c	This parameter holds the external Identifier identifying the served party associated to the IMSI or MSISDN or External Group ID, if available
SCEF ID	O _c	This parameter holds the Diameter identity of the SCEF used for API invocation.
SCEF Address	O _c	This parameter holds the IP address of SCEF.
API Identifier	O _M	This parameter holds the identity of API
SCS/AS Address	O _M	This parameter holds the IP address of SCS/AS which invoke the API via T8 interface
TLTRI	O _c	This parameter holds T8 Long Term Transaction Reference ID is which refers to long term transaction (e.g. NIDD Configuration, Group Message Request, Monitoring Event configuration) between the SCEF and the SCS/AS when using T8 interface.
Event Timestamp	M	This field holds the time stamp of the event reported.
API Invocation Timestamp	O _c	This parameter holds the time stamp when API Invocation request was submitted to the SCEF from SCS/AS.
API Direction	O _c	This field holds the direction to indicate the API invocation or API notification.
API Network Service Node	O _c	This field holds the identifier the network element (e.g. SGSN, RCAF) that triggers the API notification, as defined in 23.682 [243].
API Content	O _c	This parameter holds the API content (e.g. Location, Monitoring Type) used in the T8 transaction for the API invocation request, if available.
API Size	O _c	This parameter holds size of API payload.
API Result Code	O _c	This parameter holds the result of API Invocation.

6.3.1.3 Supported features

The Supported features information that is used for Exposure Function API charging is based on the information defined for the supported features mechanism specified in clause 6.5.10 of TS 32.299 [50].

The following table defines the features applicable for the feature lists with a Feature-List-ID of 1.

Table 6.3.1.3.1: Features of Feature-List-ID 1 used in Exposure Function API charging

Feature bit	Feature	Description	Online/Offline
0	NAPS-CH	This feature indicates the support Exposure Function API charging.	Both
Feature bit: The order number of the bit within the Feature-List AVP where the least significant bit is assigned number "0". Feature: A short name that can be used to refer to the bit and to the feature, e.g., "EPS". Feature in this table is always mandatory since it relates to the charging functionality of a network feature. Description: A clear textual description of the feature.			

6.3.1.4 Definition of the NEF API Information

6.3.1.4.1 Definition of the NEF API Charging Information

Network Exposure Function API specific charging information is provided within the NEF API Charging Information. The detailed structure of the NEF API Charging Information can be found in table 6.3.1.4.1.

Table 6.3.1.4.1: Structure of the NEF API Charging Information

Information Element	Category	Description
External Individual Identifier	O _c	This parameter holds the external Identifier of the individual UE, e.g., the GPSI.
External Individual Id List	O _c	This parameter holds a list of external identifiers, used instead of External Individual Identifier if there is more than one.
Internal Individual Identifier	O _c	This parameter holds the internal Identifier of the individual UE e.g., the SUPI.
Internal Individual Id List	O _c	This parameter holds a list of internal identifiers, used instead of Internal Individual Identifier if there is more than one.
External Group Identifier	O _c	This parameter holds the external identifier for a group of individual UE(s).
Internal Group Identifier	O _c	The internal Identifier identifying a group of individual UE(s).
API Direction	O _c	This field holds the direction to indicate if it is : - an API invocation from AF to NEF - a notification from NEF to AF - an API invocation from API Invoker/API Provider to CCF - a notification from CCF to API Invoker/API Provider
API Target Network Function	O _c	This field holds the identifier of the network function that either is the destination of the API invocation or triggers the notification: e.g. PCF, UDM, AMF, SMF, UPF., IMS Node, AIOTF.
API Result Code	O _c	This parameter holds the result of API Invocation.
API Name	M	This field holds the name of the API invoked.
API Operation	O _c	This field holds the operation of the API invoked, together with detailed description.
API Reference	O _c	This field holds the reference to the definition of the format of the API invocation, this can be a URI or refence to the standard where it's specified
API Content	O _c	This field holds the actual content of the API invocation, in the format described by the API Reference

6.3.2 Detailed message format for offline charging

The following clause specifies per Operation Type the charging data that are sent by SCEF for Exposure Function API offline charging.

The Operation Types are listed in the following order: S (Start)/I (Interim)/S (Stop)/E (Event). Therefore, when all Operation Types are possible it is marked as SISE. If only some Operation Types are allowed for a node, only the appropriate letters are used (i.e. SIS or E) as indicated in the table heading. The omission of an Operation Type for a particular field is marked with "-" (i.e. SI-E). Also, when an entire field is not allowed in a node the entire cell is marked as "-".

Table 6.3.2.1 illustrates the basic structure of the supported fields in the *Charging Data Request* message for Exposure Function API offline charging.

Table 6.3.2.1: Supported fields in *Charging Data Request* message

Information Element	Node Type	SCEF
	Supported Operation Types	S/I/S/E
Session Identifier		---E
Originator Host		---E
Originator Domain		---E
Destination Domain		---E
Operation Type		---E
Operation Number		---E
Operation Identifier		---E
User Name		---E
Destination Host		---E
Operation Interval		---E
Origination State		---E
Origination Timestamp		---E
Proxy Information		---E
Route Information		---E
Operation Token		---E
Subscriber Identifier		---E
Service Information with IMS Information and Exposure Function API Information		
Supported Features		---E
Node Functionality		---E
External Identifier		---E
SCEF ID		---E
SCEF Address		---E
TLTRI		---E
API Identifier		---E
SCS/AS Address		---E
Event Timestamp		---E
API Invocation Timestamp		---E
API Direction		---E
API Network Service Node		---E
API Content		---E
API Size		---E
API Result Code		---E

Table 6.3.2.2 illustrates the basic structure of the supported fields in the *Charging Data* Response message for Exposure function API offline charging.

Table 6.3.2.2: Supported fields in *Charging Data* Response message

Information Element	Node Type	SCEF
	Supported Operation Types	S/I/S/E
Session Identifier		---E
Operation Result		---E
Originator Host		---E
Originator Domain		---E
Operation Type		---E
Operation Number		---E
Operation Identifier		---E
Operation Interval		---E
Error Reporting Host		---E
Origination State		---E
Origination Timestamp		---E
Proxy Information		---E
Session Identifier		---E
Service Information with Exposure Function API Information		
Supported Features		---E

6.3.3 Detailed message format for online charging

The Operation types are listed in the following order: I [initial] /U [update]/ T [terminate]/E [event]. Therefore, when all Operation types are possible it is marked as IUTE. If only some Operation types are allowed for a node, only the appropriate letters are used (i.e. IT or E) as indicated in the table heading. The omission of an Operation type for a particular field is marked with "-" (i.e. I-E). Also, when an entire field is not allowed in a node the entire cell is marked as "-".

Table 6.3.3.1 illustrates the basic structure of the supported fields in the Debit / Reserve Units Request for exposure function API online charging.

Table 6.3.3.1: Supported fields in Debit / Reserve Units Request message

Information Element	Service Type	SCEF
	Supported Operation Types	I/U/T/E
Session Identifier		---E
Originator Host		---E
Originator Domain		---E
Destination Domain		---E
Operation Identifier		---E
Operation Token		---E
Operation Type		---E
Operation Number		---E
Destination Host		---E
User Name		---E
Origination State		---E
Origination Timestamp		---E
Subscriber Identifier		---E
Termination Cause		---E
Requested Action		---E
Multiple Operation		---E
Multiple Unit Operation		---E
Proxy Information		---E
Route Information		---E
Service Information		---E
Service Information with IMS and Exposure Function API Information		
Supported Features		---E
Node Functionality		---E
SCEF Node		---E
SCEF Address		---E
SCS/AS Address		---E
API Identifier		---E
TLTRI		---E
Event Timestamp		---E
API Invocation Timestamp		---E
API Direction		---E
API Network Service Node		---E
API Content		---E
API Size		---E
API Result Code		---E
External Identifier		---E

Table 6.3.3.2 illustrates the basic structure of the supported fields in the Debit / Reserve Units Response for exposure function API online charging.

Table 6.3.3.2: Supported fields in Debit / Reserve Units Response Message

Information Element	Node Type	SCEF
	Supported Operation Types	I/U/T/E
Session Identifier		---E
Operation Result		---E
Originator Host		---E
Originator Domain		---E
Operation Identifier		---E
Operation Type		---E
Operation Number		---E
Operation Failover		---E
Multiple Unit Operation		---E
Operation Failure Action		---E
Redirection Host		---E
Redirection Host Usage		---E
Redirection Cache Time		---E
Route Information		---E
Failed parameter		---E
Service Information		---E
Service Information with Exposure Function API Information		
Supported Features		I---

6.3.4 Detailed message format for converged charging

The operation types are listed in the following order: I (Initial) / U (Update)/T (Termination)/E (Event). Therefore, when all Operation types are possible it is marked as IUTE. If only some operation types are allowed for a node, only the appropriate letters are used (e.g., IUT or E) as indicated in the table heading. The omission of an operation type for a particular field is marked with "-" (e.g., I-E). Also, when an entire field is not allowed in a node the entire cell is marked as "-".

Table 6.3.4.1 illustrates the basic structure of the supported fields in the Charging Data Request for exposure function API online charging.

Table 6.3.4.1: Supported fields in Charging Data Request message

Information Element	Node Type	NEF
	Supported Operation Types	I/UTE
Session Identifier		T
Subscriber Identifier		I-TE
Tenant Identifier		I-TE
NF Consumer Identification		I-TE
Charging Identifier		I-TE
Invocation Timestamp		I-TE
Invocation Sequence Number		I-TE
One-time Event		---E
One-time Event Type		---E
Notify URI		I---
Supported Features		I--E
Triggers		I-TE
Multiple Unit Usage		I-TE
Rating Group		I--E
Requested Unit		I--E
Used Unit Container		--TE
NEF API Charging Information		
External Individual Identifier		I-TE
External Individual Id List		I-TE
Internal Individual Identifier		I-TE
Internal Individual Id List		I-TE
External Group Identifier		I-TE
Internal Group Identifier		I-TE
API Direction		I-TE
API Target Network Function		I-TE
API Result Code		I-TE
API Name		I-TE
API Operation		I-TE
API Reference		I-TE
API Content		I-TE

Table 6.3.4.2 illustrates the basic structure of the supported fields in the Charging Data Response for exposure function API converged charging.

Table 6.3.4.2: Supported fields in Charging Data Response Message

Information Element	Node Type	NEF
	Supported Operation Types	I/UTE
Session Identifier		I-TE
Invocation Timestamp		I-TE
Invocation Result		I-TE
Invocation Sequence Number		I-TE
Session Failover		I-TE
Supported Features		I--E
Multiple Unit Information		I--E
Result Code		I--E
Rating Group		I--E
Granted Unit		I--E
Validity Time		I--E

6.4 Bindings for Northbound API offline charging

This clause aims to describe the mapping between the Service Information fields, AVPs, Ies and CDR parameters for exposure function API online and offline charging.

Table 6.4.1 describes the mapping of the Diameter Accounting AVP, Ies and CDR to the CDR parameters of EA-SCE-CDR.

Table 6.4.1: Bindings of CDR Parameters, Information Elements and AVPs

CDR Parameter	Information Element	AVP
Service Context Id	Service Context Id	Service-Context-Id
	Service Information	Service-Information
	IMS Information	IMS-Information
Record Type	Node Functionality	Node-Functionality
	API invocation Information	API-invocation-Information
-	Supported Features	Supported-Features
External Identifier	External Identifier	External-Identifier
SCEF ID	SCEF ID	SCEF-ID
SCEF Address	SCEF Address	SCEF-Address
SCS/AS Address	SCS/AS Address	SCS/AS- Address
API Identifier	APIIdentifier	API-Identifier
TLTRI	TLTRI	TLTRI
Event Timestamp	Event Timestamp	Event-Timestamp
API Invocation Timestamp	API Invocation Timestamp	API-Invocation-Timestamp
API Direction	API Direction	API-Direction
API Network Service Node	API Network Service Node	API-Network-Service-Node
API Content	API Content	API -Content
API Size	API Size	API-Size
API Result Code	API Result Code	API-Result-Code

6.5 Bindings for NEF Northbound API converged charging

This mapping between the Information Elements, resource attributes and CHF CDR parameters for NEF Northbound API converged charging is described in clause 7 of TS 32.291 [58].

6.6 Data description for CAPIF Core Function converged charging

6.6.1 Message contents

6.6.1.1 General

The Charging Data Request and Charging Data Response are specified in TS 32.290 [57] and include charging information. The Charging Data Request can be of type [Event, Initial, Termination].

Table 6.6.1.1.1 describes the use of these messages for converged charging.

Table 6.6.1.1.1: Converged charging messages reference table

Message	Source	Destination
Charging Data Request	CCF	CHF
Charging Data Response	CHF	CCF

The following clauses describe the different fields used in the Charging Data messages and the category in the tables is used according to the charging data configuration defined in clause 5.4 of TS 32.240 [2].

The basic structure of a Charging Data Request/Response message from/to the CCF as used for CAPIF charging, can reuse the structure and information elements for NEF converged charging.

- The common information elements (e.g, tenant identifier holds the API invoker id) refers to the TS 32.290 [57].
- The CAPIF API charging information which hold the CAPIF Core Function specific information can mapped to the NEF API Charging information (e.g, including the API name, API contents) specified in clause 6.3.1.4.

6.6.1.2 Structure for the converged charging message formats

6.6.1.2.1 Charging Data Request message

The basic structure of a Charging Data Request message as used for CCF converged charging is illustrated in Table 6.2a.1.2.1.1.

6.6.1.2.2 Charging Data Response message

The basic structure of a Charging Data Response message as used for CCF converged charging is illustrated in Table 6.2a.1.2.2.1.

6.6.2 G_a message contents

Refer to clause 5.4.4.

6.6.3 CDR description on the B_{ea} interface

6.6.3.1 General

The CDR content and format generated for CCF converged charging can reuse the NEF converged charging specified in the clause 6.2a.3.

The fields of CAPIF charging CHF CDR includes:

- The common information elements (e.g, record type for CAPIF Charging) refers to the TS 32.298 [3].
- The CAPIF API charging information which hold the CAPIF Core Function specific information can mapped to the NEF API Charging information specified in clause 6.3.1.4.

Annex A (normative): Charging characteristics

A.1 General

A subscriber (The API Invoker) may have Charging Characteristics assigned to his subscription. Default charging characteristics may be pre-provisioned on the SCEF. The charging information content is configured for each API, including charging method (online and offline charging), Event based charging, whether report the message content or not.

The Charging Characteristics parameter format is specified TS 32.298 [51]. Each bit of the string of 16 bits corresponds to a specific charging behaviour which is defined on a per operator basis, configured within the SCEF and pointed when bit is set to "1" value.

One way to define a charging behaviour could be to associate it to a specific usage, which may consist of a set of trigger profiles associated to CDR types e.g.:

- **EA-SCE-CDR:** activate/deactivate CDRs, time limit, data volume limit, maximum number of API invocation.

In addition to these trigger sets, a CDF/CGF address may also be included.

Annex B (normative): Support 5G VN group management charging

B.1 General

This Annex describes the CEF (with UDM) support the 5G VN group management charging which specified in clause 6.2 TS 32.240 [1].

The CEF based 5G VN group management charging is an alternative to the NEF based, and may be used instead of the NEF based for the 5G VN group management charging.

B.2 Charging Architecture for 5G VN group management charging

B.2.1 General

The 5G VN group management converged charging architecture including CEF based charging specified in the following clause B.2.1.1.

B.2.1.1 Logical Charging architecture - CEF based charging

The logical ubiquitous charging architecture and the reference points for 5G VN group management with the CEF architecture is shown in figure B.2.1-1.

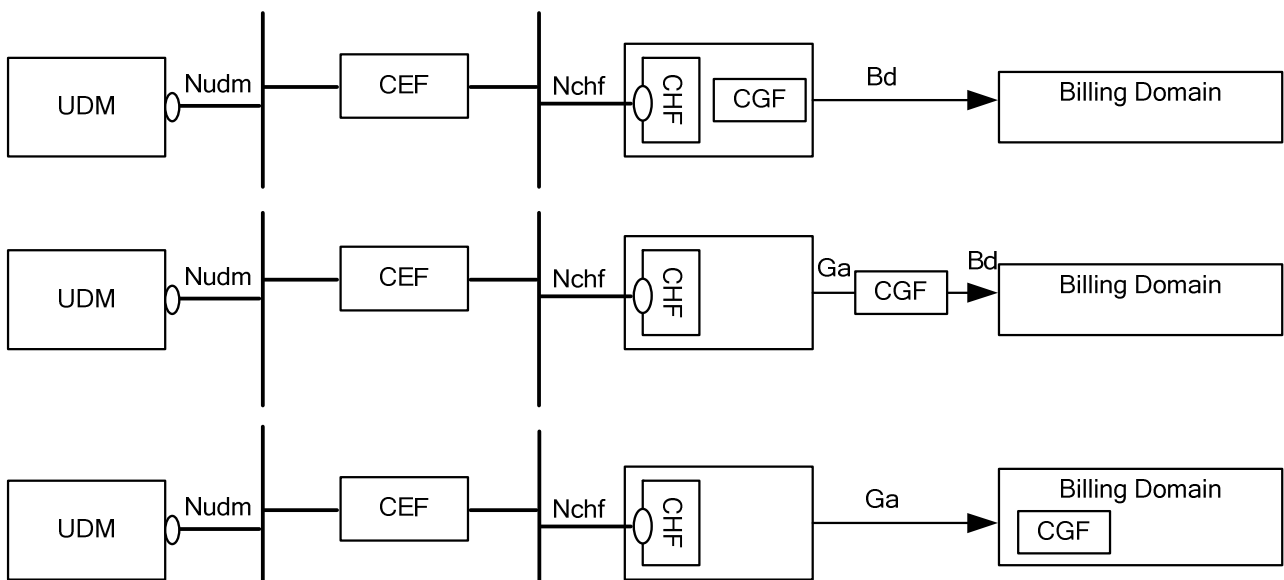

Figure B.2.1.1-1: Logical ubiquitous charging architecture for 5G VN group management with the CEF architecture

B.2.2 Void

B.2.3 Charging principles and scenarios

B.2.3.1 Basic principles

5G VN group management charging is performed by the NEF or CEF interacting with CHF using Nchf specified in TS 32.290 [57] and TS 32.291 [58]. In order to provide the data required for the charging management activities, the converged charging can be performed for each of the following:

- The CEF are able to get the 5G VN group information (e.g. GroupIdentifiers) from UDM via Nudm_SubscriberDataManagement service, specified in the TS 23.502 [214] and TS 29.503[236]. The Charging Data Request and Charging Data Response are exchanged between the CEF and the CHF, based on PEC scenarios as specified in TS 32.290 [57]. The Charging Data Request is issued by the CEF towards the CHF when certain conditions (chargeable events) are met.

The CEF only uses the GET operation of Nudm_SubscriberDataManagement service to obtain the 5G VN group information.

- The NEF are able to report the 5G VN group information (e.g. add/delete 5G VN Group members) to CHF based on the API invocation (i.e. 5GLANParameterProvision API) chargeable events.

In order to avoid the duplicate charging, the NEF based and CEF based 5G VN group management charging will not be invoked at the same time, which depend on the implementation based on the operator policy.

The 5G VN group management charging information is collected per VN group. The message contents and purpose of each charging event that triggers interaction with CHF, as well as the chargeable events that trigger them, are described in following clauses.

A detailed formal description of the converged charging parameters to CHF defined in the present document can be found in TS 32.291 [58].

A detailed formal description of the CDR parameters defined in the present document can be found in TS 32.298 [51].

B.2.3.2 Applicable triggers in 5G VN group management charging

B.2.3.2.1 5G VN group management charging via UDM

A set of trigger conditions are defined for the CEF to invoke a Charging Data Request [Event] towards the CHF.

Table B.2.3.2.1-1 summarizes the set of default trigger conditions and their category which shall be supported by the CEF.

Table B.2.3.2.1-1: Default Trigger conditions in CEF

Trigger Conditions	Trigger level	Default category	CHF allowed to change category	CHF allowed to enable and disable	Message when "immediate reporting" category
Receive the 5G VN group information from UDM	-	Immediate	Not Applicable	Not Applicable	Charging Data Request [Event]

B.2.3.3 Message flows

B.2.3.3.1 5G VN group management charging via UDM

The following message flow specifies the interaction between the CEF and the CHF for 5G VN group management charging. This interaction is based on Charging Data Request /Response specified in TS 32.290 [57].

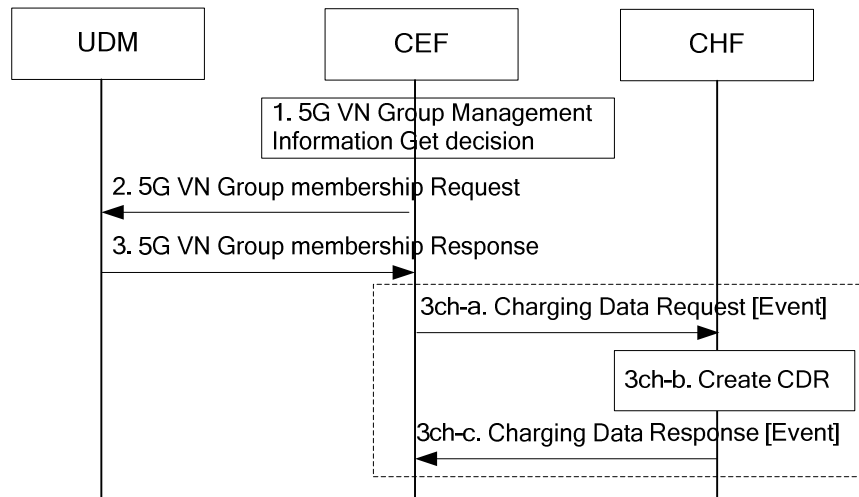

Figure B.2.3.3.1-1: Message flow for CEF interaction for 5G VN group charging---PEC

1. The CEF decides to get the 5G VN group management information based on the charging requirement.
2. The CEF sends the 5G VN group management information Request to the UDM via Nudm_SubscriberDataManagement service.
3. The UDM sends the 5G VN group management information successful Response to the CEF, including current VN group information, e.g. the Internal Group ID, External Group ID, and UE Id List.
- 3ch-a. The CEF sends Charging Data Request [Event] to CHF for 5G VN group management information.
- 3ch-b. The CHF creates a CDR.
- 3ch-c. The CHF acknowledges by sending Charging Data Response [Event] to the CEF.

B.2.3.4 CDR generation

The CHF CDRs for 5G VN group management charging are generated by the CHF to collect charging information that they subsequently transfer to the Charging Gateway Function (CGF).

A 5G VN group management CHF CDR is used to capture charging information related to 5G VN group management chargeable events and is generated by the CHF for each received Charging Data Request [Event].

B.2.4 Charging Information

B.2.4.1 Data description for 5G VN group management charging

The Charging Data Request and Charging Data Response are specified in subclause 5.1.2.2.1 of TS 32.290 [57].

Table B.2.4.1-1 describes the use of these messages for 5G VN group management charging.

Table B.2.4.1-1: 5G LAN VN group management messages reference table

Message	Source	Destination
Charging Data Request	CEF/NEF	CHF
Charging Data Response	CHF	CEF/NEF

Table B.2.4.1-2 illustrates the basic structure of a Charging Data Request message from the CEF as used for 5G VN group management charging.

Table B.2.4.1-2: Charging Data Request message contents

Information Element	Category for converged charging	Description
Session Identifier	O _C	Described in TS 32.290 [57]
Tenant Identifier		Described in TS 32.290 [57]
NF Consumer Identification	O _C	Described in TS 32.290 [57]
NF Functionality	M	Described in TS 32.290 [57]
NF Name	O _C	Described in TS 32.290 [57]
NF Address	O _C	Described in TS 32.290 [57]
NF PLMN ID	O _C	Described in TS 32.290 [57]
Invocation Timestamp	M	Described in TS 32.290 [57]
Invocation Sequence Number	M	Described in TS 32.290 [57]
One-time Event	O _C	Described in TS 32.290 [57]
One-time Event Type	O _C	Described in TS 32.290 [57]
Retransmission Indicator	O _C	Described in TS 32.290 [57]
Supported Features	O _C	Described in TS 32.290 [57]
Service Specification Information	O _C	Described in TS 32.290 [57]
5G VNGM Charging Information	O _M	This field is mapped to the NEF API Charging information defined in clause 6.3 for 5G VN group management charging

Table B.2.4.1-3 illustrates the basic structure of a Charging Data Response message from the CHF to CEF as used for 5G VN group management charging.

Table B.2.4.1-3: Charging Data Response message contents

Information Element	Category for converged charging	Description
Session Identifier	O _C	Described in TS 32.290 [57]
Invocation Timestamp	M	Described in TS 32.290 [57]
Invocation Result	O _C	Described in TS 32.290 [57]
Invocation Result	O _C	Described in TS 32.290 [57]
Failed parameter	O _C	Described in TS 32.290 [57]
Failure Handling	O _C	Described in TS 32.290 [57]
Invocation Sequence Number	M	Described in TS 32.290 [57]
Supported Features	O _C	Described in TS 32.290 [57]

Details of the Ga message contents are specified in TS 32.295 [54].

The following table B.2.4.1-4 provide a brief description of each CDR parameter. The category in the tables is used according to the charging data configuration defined in clause 5.4. Full definitions of the CDR parameters, sorted by the name in alphabetical order, are provided in TS 32.298 [51].

Table B.2.4.1-4 5G VN group management charging CHF record data

Field	Category	Description
Record Type	M	CHF record.
Recording Network Function ID	O _M	This field holds the name of the recording entity, i.e. the CEF id.
Tenant Identifier	O _C	Described in TS 32.298 [57].
NF Consumer Information	M	This field holds the information of the entity that used the charging service (i.e. NF consumer (CTF), CEF).
NF Functionality	M	This field contains the function of the entity: Service Producer (CTF) or CEF
NF Name	O _C	This field holds the name of the entity.
NF Address	O _C	This field holds the IP Address of the entity
NF PLMN ID	O _C	This field holds the PLMN identifier (MCC MNC) of the entity.
Record Opening Time	M	Described in TS 32.298 [57]
Duration	M	Described in TS 32.298 [57]
Record Sequence Number	C	Described in TS 32.298 [57]
Cause for Record Closing	M	Described in TS 32.298 [57]
Diagnostics	O _M	Described in TS 32.298 [57]
Local Record Sequence Number	O _M	Described in TS 32.298 [57]
Record Extensions	O _C	Described in TS 32.298 [57]
5G VNGM Charging Information	O _M	This field is mapped to the NEF API Charging information defined in clause 6.3 for 5G VN group management charging.

B.2.4.2 Definition of 5G VN group management charging information

The 5G VN Group Management Charging information is mapped to in the "NEF API Charging Information" in the table B.2.4.2-1.

Table B.2.4.2-1: Structure of NEF API Charging Information for 5G VNGM Charging Information

5G VNGM Charging Information (Mapped to NEF API Charging Information)	Category	Description
External Group Identifier	O _C	This field contains the External Group ID associated to the provided Internal Group ID
Internal Group Identifier	O _C	This field contain the Internal Group ID associated to the provided External Group ID.
External Individual Id List	O _C	The list of the UE identifiers in the 5G VN group.
Internal Individual Id List	O _C	This field holds the list of internal Identifier of the individual UEs e.g., a list of SUPIs.
API Content	O _C	The API content includes the 5G VN group data, including the Single Nssai DNN and PDU Session Types.

B.2.4.3 Detailed message format for converged charging

The following clause specifies per Operation Type the charging data that are sent by CEF for 5G VN group management converged charging.

The Operation Types are listed in the following order: I (Initial)/T (Termination)/E (Event). Therefore, when all Operation Types are possible it is marked as ITE. If only some Operation Types are allowed for a node, only the appropriate letters are used (i.e. IT or E) as indicated in the table heading. The omission of an Operation Type for a particular field is marked with "-" (i.e. I-E). Also, when an entire field is not allowed in a node the entire cell is marked as "-".

Table B.2.4.3-1 defines the basic structure of the supported fields in the *Charging Data Request* message for CEF converged charging.

Table B.2.4.3-1: Supported fields in *Charging Data Request* message

Information Element	Analytics and Performance	CEF
	Supported Operation Types	E
Session Identifier		E
Tenant Identifier		E
NF Consumer Identification		E
NF Functionality		E
NF Name		E
NF Address		E
NF PLMN ID		E
Invocation Timestamp		E
Invocation Sequence Number		E
One-time Event		E
One-time Event Type		E
Retransmission Indicator		E
Supported Features		E
Service Specification Information		E
5G VNGM Charging Information		E

Table B.2.4.3-2 defines the basic structure of the supported fields in the *Charging Data Response* message for CEF converged charging.

Table B.2.4.3-2: Supported fields in *Charging Data Response* message

Information Element	Analytics and Performance	CEF
	Supported Operation Types	E
Session Identifier		E
Invocation Timestamp		E
Invocation Result		E
Invocation Result		E
Failed parameter		E
Failure Handling		E
Invocation Sequence Number		E
Supported Features		E

B.2.5 Bindings for 5G VN group management converged charging

This mapping between the Information Elements, resource attributes and CHF CDR parameters for 5G VN group management and communication converged charging is described in clause 7 of TS 32.291 [51].

Annex C (informative): PlantUML source code

C.1 Procedures for Northbound API converged online and offline charging scenarios

C.1.1 CAPIF Invoker and Provider Request (PEC)

```
@startuml
participant "API Invoker / API Provider" as API
participant "CAPIF Core Function" as CAPIF
participant "CHF" as CHF

API -> CAPIF : 1. API Management Request

rnote over CAPIF #white
    2. API invoker management procedure
endrnote
CAPIF -> API : 3. API Management Response

group Charging Event Procedure
    CAPIF -> CHF : 3ch-a. Charging Data Request [Event]

    rnote over CHF #white
        3ch-b. Create CDR
    endrnote
    CHF -> CAPIF : 3ch-c. Charging Data Response [Event]
end
@enduml
```

Annex D (informative): Change history

Change history							
Date	Meeting	Tdoc	CR	Rev	Cat	Subject/Comment	New version
2018-06	SA#80					Upgrade to change control version	15.0.0
2018-12	SA#82	SP-181041	0001	1	F	Correction on the TTRL and TLTRL	15.1.0
2019-03	SA#83	SP-190114	0002	1	B	Add convergent charging architecture	16.0.0
2019-03	SA#83	SP-190114	0003	1	B	Add basic principles for convergent charging	16.0.0
2019-03	SA#83	SP-190114	0004	1	B	Add message flows for convergent charging	16.0.0
2019-03	SA#83	SP-190114	0005	1	B	Adding CDR generation and handling for convergent charging	16.0.0
2019-06	SA#84	SP-190380	0006	1	B	Addition of NEF charging data for Converged Charging	16.1.0
2019-06	SA#84	SP-190380	0007	1	B	Adding NEF API Information for charging	16.1.0
2019-09	SA#85	SP-190756	0009	1	B	Update of NEF API Charging Information	16.2.0
2019-09	SA#85	SP-190756	0010	1	B	Addition of detailed message format for convergent charging	16.2.0
2020-07	SA#88-E	SP-200484	0011	1	F	Add the Retransmission Indicator	16.3.0
2020-07	SA#88-E	SP-200484	0012	1	F	Correct the message content for NEF charging	16.3.0
2021-03	SA#91e	SP-210159	0013	-	F	Correction on applicable scenarios and flows	16.4.0
2021-03	SA#91e	SP-210159	0014	1	F	Correction on different identities	16.4.0
2021-03	SA#91e	SP-210159	0015	1	F	Correction on Multiple Unit Usage	16.4.0
2021-03	SA#91e	SP-210159	0016	-	F	Correction on binding description	16.4.0
2021-06	SA#92e	SP-210407	0017	1	C	Correction on Reference Points	17.0.0
2022-06	SA#96	SP-220518	0018	1	B	Addition of the 5G VN group management Charging Architecture	17.1.0
2022-06	SA#96	SP-220518	0019	1	B	Addition of the 5G VN group management Charging Principles	17.1.0
2022-06	SA#96	SP-220518	0020	1	B	Addition of the 5G VN group management Charging	17.1.0
2022-06	SA#96	SP-220565	0022	1	A	Correction on the NEF API Charging information	17.1.0
2022-06	SA#97e	SP-220867	0024	-	F	Correction on the 5G LAN VN management converged charging	17.2.0
2022-06	SA#98e	SP-221192	0026	1	A	Correction on the Triggers for the NEF	17.3.0
2022-06	SA#98e	SP-221192	0028	1	A	Correction on the notifyURI for NEF Charging	17.3.0
2023-03	SA#99	SP-230201	0023	5	F	Missing operation and identifier in NEF charging information	18.0.0
2023-03	SA#99	SP-230201	0029	1	F	Correcting supported feature and charging identifier	18.0.0
2023-09	SA#101	SP-230945	0031	1	A	Correction on API Target Network Function information	18.1.0
2023-12	SA#102	SP-231462	0034	1	B	Rel-18 CR TS 32254 AI/ML support for NEF based charging	18.2.0
2023-12	SA#102	SP-231488	0038	1	A	Rel-18 CR 32.254 Correcting identifiers as a list	18.2.0
2023-12	SA#102	SP-231491	0042	1	A	Rel-18 CR 32.254 Correct the 5G VNGM Charging Information	18.2.0
2023-12	SA#102	SP-231497	0043	1	B	Rel-18 CR 32.254 Add charging support for TSN service	18.2.0
2024-06	SA#104	SP-240810	0047	3	F	Rel-18 CR TS 32.254 Application Charging Enhancement	18.3.0
2024-06	SA#104	SP-240810	0048	1	F	Rel-18 CR 32.254 Correction on trigger for NEF message content	18.3.0
2024-06	SA#104	SP-240810	0049	1	F	Rel-18 CR 32.254 Add tenant identifier and correct charging information for 5G VN group management charging	18.3.0
2024-06	SA#104	SP-240810	0050	1	F	Rel-18 CR 32.254 Correction on session identifier	18.3.0
2024-06	SA#104	SP-240810	0051	1	F	Rel-18 CR 32.254 Correction of charging information applicability	18.3.0
2024-12	SA#106	SP-241643	0054	1	F	Rel-18 CR 32.254 Correction on Attributes	18.4.0
2024-12	SA#106	SP-241643	0053	2	F	Add charging support for Ranging and Sidelink Positioning service	19.0.0
2025-06	SA#108	SP-250524	0060	1	B	Rel-19 CR 32.254 Addition of the CAPIF Charging Message Content	19.1.0
2025-06	SA#108	SP-250542	0061	1	B	Rel-19 CR 32.254 Add charging principle for IMS network capabilities exposure	19.1.0
2025-06	SA#108	SP-250524	0062	1	B	Rel-19 CR 32.254 Addition of charging architecture for CAPIF	19.1.0
2025-06	SA#108	SP-250524	0063	1	B	Rel-19 CR 32.254 Addition of charging principles for CAPIF	19.1.0
2025-06	SA#108	SP-250524	0064	1	B	Rel-19 CR 32.254 CAPIF API Invoker Charging Flow	19.1.0
2025-06	SA#108	SP-250524	0065	1	B	Rel-19 CR 32.254 CAPIF Triggers	19.1.0
2025-06	SA#108	SP-250524	0068		B	Rel-19 CR 32.254 CAPIF Message Flows Introduction	19.1.0
2025-06	SA#108	SP-250524	0069	1	B	Rel-19 CR 32.254 Addition of the CAPIF Charging Principle	19.1.0
2025-06	SA#108	SP-250522	0071	1	D	Rel-19 CR 32.254 Add charging support to AIoT service	19.1.0
2025-06	SA#108	SP-250524	0072	1	B	Rel-19 CR 32.254 Addition of CAPIF specific charging information	19.1.0
2025-09	SA#109	SP-251110	0075	1	B	Rel-19 CR 32.254 CAPIF API Invoker Charging Flow (ECUR)	19.2.0
2025-09	SA#109	SP-251171	0076	2	B	Rel-19 CR 32.254 CAPIF API Events	19.2.0
2025-09	SA#109	SP-251117	0077	1	F	Rel-19 CR 32.254 Correction of Ranging and Sidelink Positioning service in Northbound API procedures	19.2.0
2025-09	SA#109	SP-251114	0078	1	F	Rel-19 CR 32.254 Addition of AIoT service in Northbound API procedures	19.2.0
2025-11	SA#109	-	-	-	-	Correction of change history annex order to Annex D	19.2.1

History

Document history		
V19.2.0	October 2025	Publication (withdrawn)
V19.2.1	December 2025	Publication