

ETSI TS 132 256 V19.4.0 (2026-02)



TECHNICAL SPECIFICATION

**5G;
Charging management;
5G connection and mobility domain charging;
Stage 2
(3GPP TS 32.256 version 19.4.0 Release 19)**



Reference

RTS/TSGS-0532256vj40

Keywords

5G

ETSI

650 Route des Lucioles
F-06921 Sophia Antipolis Cedex - FRANCE

Tel.: +33 4 92 94 42 00 Fax: +33 4 93 65 47 16

Siret N° 348 623 562 00017 - APE 7112B
Association à but non lucratif enregistrée à la
Sous-Préfecture de Grasse (06) N° w061004871

Important notice

The present document can be downloaded from the
[ETSI Search & Browse Standards](#) application.

The present document may be made available in electronic versions and/or in print. The content of any electronic and/or print versions of the present document shall not be modified without the prior written authorization of ETSI. In case of any existing or perceived difference in contents between such versions and/or in print, the prevailing version of an ETSI deliverable is the one made publicly available in PDF format on [ETSI deliver](#) repository.

Users should be aware that the present document may be revised or have its status changed,
this information is available in the [Milestones listing](#).

If you find errors in the present document, please send your comments to
the relevant service listed under [Committee Support Staff](#).

If you find a security vulnerability in the present document, please report it through our
[Coordinated Vulnerability Disclosure \(CVD\)](#) program.

Notice of disclaimer & limitation of liability

The information provided in the present deliverable is directed solely to professionals who have the appropriate degree of experience to understand and interpret its content in accordance with generally accepted engineering or other professional standard and applicable regulations.

No recommendation as to products and services or vendors is made or should be implied.

No representation or warranty is made that this deliverable is technically accurate or sufficient or conforms to any law and/or governmental rule and/or regulation and further, no representation or warranty is made of merchantability or fitness for any particular purpose or against infringement of intellectual property rights.

In no event shall ETSI be held liable for loss of profits or any other incidental or consequential damages.

Any software contained in this deliverable is provided "AS IS" with no warranties, express or implied, including but not limited to, the warranties of merchantability, fitness for a particular purpose and non-infringement of intellectual property rights and ETSI shall not be held liable in any event for any damages whatsoever (including, without limitation, damages for loss of profits, business interruption, loss of information, or any other pecuniary loss) arising out of or related to the use of or inability to use the software.

Copyright Notification

No part may be reproduced or utilized in any form or by any means, electronic or mechanical, including photocopying and microfilm except as authorized by written permission of ETSI.

The content of the PDF version shall not be modified without the written authorization of ETSI.

The copyright and the foregoing restriction extend to reproduction in all media.

© ETSI 2026.
All rights reserved.

Intellectual Property Rights

Essential patents

IPRs essential or potentially essential to normative deliverables may have been declared to ETSI. The declarations pertaining to these essential IPRs, if any, are publicly available for **ETSI members and non-members**, and can be found in ETSI SR 000 314: "*Intellectual Property Rights (IPRs); Essential, or potentially Essential, IPRs notified to ETSI in respect of ETSI standards*", which is available from the ETSI Secretariat. Latest updates are available on the [ETSI IPR online database](#).

Pursuant to the ETSI Directives including the ETSI IPR Policy, no investigation regarding the essentiality of IPRs, including IPR searches, has been carried out by ETSI. No guarantee can be given as to the existence of other IPRs not referenced in ETSI SR 000 314 (or the updates on the ETSI Web server) which are, or may be, or may become, essential to the present document.

Trademarks

The present document may include trademarks and/or tradenames which are asserted and/or registered by their owners. ETSI claims no ownership of these except for any which are indicated as being the property of ETSI, and conveys no right to use or reproduce any trademark and/or tradename. Mention of those trademarks in the present document does not constitute an endorsement by ETSI of products, services or organizations associated with those trademarks.

DECT™, **PLUGTESTS™**, **UMTS™** and the ETSI logo are trademarks of ETSI registered for the benefit of its Members. **3GPP™**, **LTE™** and **5G™** logo are trademarks of ETSI registered for the benefit of its Members and of the 3GPP Organizational Partners. **oneM2M™** logo is a trademark of ETSI registered for the benefit of its Members and of the oneM2M Partners. **GSM®** and the GSM logo are trademarks registered and owned by the GSM Association.

Legal Notice

This Technical Specification (TS) has been produced by ETSI 3rd Generation Partnership Project (3GPP).

The present document may refer to technical specifications or reports using their 3GPP identities. These shall be interpreted as being references to the corresponding ETSI deliverables.

The cross reference between 3GPP and ETSI identities can be found at [3GPP to ETSI numbering cross-referencing](#).

Modal verbs terminology

In the present document "**shall**", "**shall not**", "**should**", "**should not**", "**may**", "**need not**", "**will**", "**will not**", "**can**" and "**cannot**" are to be interpreted as described in clause 3.2 of the [ETSI Drafting Rules](#) (Verbal forms for the expression of provisions).

"**must**" and "**must not**" are **NOT** allowed in ETSI deliverables except when used in direct citation.

Contents

Intellectual Property Rights	2
Legal Notice	2
Modal verbs terminology.....	2
Foreword.....	6
1 Scope	8
2 References	8
3 Definitions of terms, symbols and abbreviations	9
3.1 Terms.....	9
3.2 Symbols.....	10
3.3 Abbreviations	10
4 Architecture considerations	10
4.1 High-level 5G System architecture	10
4.1.1 Non-roaming reference architecture	10
4.1.2 Roaming reference architecture	11
4.1.3 Architecture reference for network sharing support	12
4.1.3.1 Indirect Network Sharing	12
4.2 5G connection and mobility domain converged charging architecture	13
4.2.1 Non-roaming.....	13
4.2.2 Roaming.....	14
4.3 5G connection and mobility converged charging Consumer CHF to Business CHF architecture	15
5 5G connection and mobility charging principles and scenarios	16
5.1 5G connection and mobility charging principles.....	16
5.1.1 General.....	16
5.1.2 Requirements	16
5.1.3 CHF selection	17
5.1.4 UE Presence in Presence Reporting Area (PRA).....	17
5.1.5 Roaming.....	17
5.1.5.1 General	17
5.1.5.2 CHF selection.....	17
5.2 5G connection and mobility converged online and offline charging scenarios	18
5.2.1 Basic principles.....	18
5.2.1.1 General	18
5.2.1.2 Applicable Triggers in the AMF	18
5.2.1.2.1 General	18
5.2.1.2.2 AMF Charging profile	19
5.2.1.2.3 Independent triggers activation/deactivation	20
5.2.1.3 UE Presence in Presence Reporting Area (PRA).....	20
5.2.1.4 NR REDCAP Charging.....	21
5.2.1.5 PNI-NPN Charging	21
5.2.1.6 SNPN Charging.....	21
5.2.1.7 Support for satellite access charging	21
5.2.1.8 UAS Charging.....	21
5.2.2 Message flows	22
5.2.2.1 General	22
5.2.2.2 Registration management charging from AMF.....	22
5.2.2.2.1 General	22
5.2.2.2.2 General Registration – PEC charging.....	22
5.2.2.2.3 General Registration – IEC.....	24
5.2.2.2.4 General Registration – ECUR	25
5.2.2.2.5 Registration with AMF re-allocation – PEC charging.....	26
5.2.2.2.6 Registration with AMF re-allocation – IEC	26
5.2.2.2.7 Registration with AMF re-allocation – ECUR	26
5.2.2.2.8 Deregistration – PEC charging	26

5.2.2.2.9	Registration – Untrusted non-3GPP access - PEC charging.....	28
5.2.2.2.10	Registration – Untrusted non-3GPP access - IEC	29
5.2.2.2.11	Registration – Untrusted non-3GPP access - ECUR	30
5.2.2.2.12	Registration for SMS over NAS – PEC charging.....	31
5.2.2.2.13	Registration for SMS over NAS – IEC.....	32
5.2.2.2.14	Registration for SMS over NAS – ECUR	33
5.2.2.2.15	Deregistration for SMS over NAS – PEC charging.....	34
5.2.2.3	Connection management charging from AMF.....	34
5.2.2.3.1	General	34
5.2.2.3.2	UE Triggered Service Request	35
5.2.2.3.3	Network Triggered Service Request.....	35
5.2.2.3.4	AN release	35
5.2.2.4	Location reporting charging.....	36
5.2.2.4.1	General	36
5.2.2.4.2	Location reporting	36
5.2.2.5	Roaming - Registration management charging from AMF.....	38
5.2.2.5.1	General	38
5.2.2.5.2	Registration - PEC to HPLMN and AMF to H-CHF and V-CHF	38
5.2.2.5.3	Registration – IEC to HPLMN and AMF to H-CHF and V-CHF	40
5.2.2.5.4	Registration – ECUR to HPLMN and AMF to H-CHF and V-CHF	41
5.2.2.5.5	Deregistration – PEC to HPLMN and AMF to H-CHF and V-CHF	43
5.2.2.5.6	Registration - PEC to HPLMN and AMF to V-CHF.....	44
5.2.2.5.7	Registration – IEC to HPLMN and AMF to V-CHF.....	45
5.2.2.5.8	Registration – ECUR to HPLMN and AMF to V-CHF.....	47
5.2.2.5.9	Deregistration – PEC to HPLMN and AMF to V-CHF.....	49
5.2.2.6	UE registration charging based on Business converged charging.....	50
5.2.2.6.1	General	50
5.2.2.6.2	Registration - ECUR.....	51
5.2.3	CDR generation	52
5.2.3.1	Introduction.....	52
5.2.3.2	Triggers for CHF CDR.....	52
5.2.3.2.1	General	52
5.2.3.2.2	Triggers for CHF CDR generation	52
5.2.3.2.3	Triggers for CHF CDR opening	52
5.2.3.2.4	Triggers for CHF CDR closure	52
5.2.4	Ga record transfer flows	52
5.2.5	Bam CDR file transfer	52
6.	Definition of charging information	52
6.1	Data description for 5G connection and mobility charging.....	52
6.1.1	Message contents	52
6.1.1.1	General	52
6.1.1.2	Charging Data Request message	53
6.1.1.3	Charging data response message.....	54
6.1.2	Ga message contents	54
6.1.3	CDR description on the B _{am} interface.....	54
6.1.3.1	General	54
6.1.3.2	Registration charging CHF CDR data.....	54
6.1.3.3	N2 connection charging Information CHF CDR data.....	55
6.1.3.4	Location reporting charging CHF CDR data.....	56
6.2	5G connection and mobility charging specific parameters.....	57
6.2.1	Definition of 5G connection and mobility charging information.....	57
6.2.1.1	General	57
6.2.1.2	Definition of registration charging information	58
6.2.1.3	Definition of N2 Connection charging information	59
6.2.1.4	Definition of Location Reporting charging information	60
6.2.1.5	Definition of inter-CHF information.....	60
6.2.2	Formal 5G connection and mobility charging parameter description.....	60
6.2.2.1	5G connection and mobility CHF CDR parameters.....	60
6.2.2.2	5G connection and mobility resources attributes	60
6.2.3	Detailed message format for converged charging.....	61
6.3	Bindings for 5G connection and mobility converged charging.....	64

Annex A (normative): Charging Characteristics65
A.1 General65
Annex B (informative): Change history66
History67

Foreword

This Technical Specification has been produced by the 3rd Generation Partnership Project (3GPP).

The contents of the present document are subject to continuing work within the TSG and may change following formal TSG approval. Should the TSG modify the contents of the present document, it will be re-released by the TSG with an identifying change of release date and an increase in version number as follows:

Version x.y.z

where:

- x the first digit:
 - 1 presented to TSG for information;
 - 2 presented to TSG for approval;
 - 3 or greater indicates TSG approved document under change control.
- y the second digit is incremented for all changes of substance, i.e. technical enhancements, corrections, updates, etc.
- z the third digit is incremented when editorial only changes have been incorporated in the document.

In the present document, certain modal verbs have the following meanings:

- shall** indicates a mandatory requirement to do something
- shall not** indicates an interdiction (prohibition) to do something

The constructions "shall" and "shall not" are confined to the context of normative provisions, and do not appear in Technical Reports.

The constructions "must" and "must not" are not used as substitutes for "shall" and "shall not". Their use is avoided insofar as possible, and they are not used in a normative context except in a direct citation from an external, referenced, non-3GPP document, or so as to maintain continuity of style when extending or modifying the provisions of such a referenced document.

- should** indicates a recommendation to do something
- should not** indicates a recommendation not to do something
- may** indicates permission to do something
- need not** indicates permission not to do something

The construction "may not" is ambiguous and is not used in normative elements. The unambiguous constructions "might not" or "shall not" are used instead, depending upon the meaning intended.

- can** indicates that something is possible
- cannot** indicates that something is impossible

The constructions "can" and "cannot" shall not to be used as substitutes for "may" and "need not".

- will** indicates that something is certain or expected to happen as a result of action taken by an agency the behaviour of which is outside the scope of the present document
- will not** indicates that something is certain or expected not to happen as a result of action taken by an agency the behaviour of which is outside the scope of the present document
- might** indicates a likelihood that something will happen as a result of action taken by some agency the behaviour of which is outside the scope of the present document

might not indicates a likelihood that something will not happen as a result of action taken by some agency the behaviour of which is outside the scope of the present document

In addition:

is (or any other verb in the indicative mood) indicates a statement of fact

is not (or any other negative verb in the indicative mood) indicates a statement of fact

The constructions "is" and "is not" do not indicate requirements.

1 Scope

The present document is part of a series of documents that specify charging functionality and charging management in 3GPP networks. The 3GPP core network charging architecture and principles are specified in TS 32.240 [1], which provides an umbrella for other charging management TSs that specify:

- the content of the CDRs per domain / subsystem / service (offline and converged charging);
- the content of real-time charging messages per domain / subsystem / service (online and converged charging);
- the functionality of online, offline and converged charging for those domains / subsystems / services;
- the interfaces that are used in the charging framework to transfer the charging information (i.e. CDRs or charging events).

The complete document structure for these TSs is defined in TS 32.240 [1].

The present document specifies the converged offline and online charging description for the 5G connection and mobility domain based on the functional stage 2 description in TS 23.501 [200], TS 23.502 [201] and TS 23.503 [202].

This charging description includes the converged offline and online charging architecture and scenarios specific to the 5G connection and mobility domain, as well as the mapping of the common 3GPP charging architecture specified in TS 32.240 [1] onto the 5G connection and mobility domain.

It further specifies the structure and content of the CDRs for offline charging, and the charging events for converged online and offline charging. The present document is related to other 3GPP charging TSs as follows:

- The common 3GPP charging architecture is specified in TS 32.240 [1].
- The parameters, abstract syntax and encoding rules for the CDRs are specified in TS 32.298 [51].
- A transaction based mechanism for the transfer of CDRs within the network is specified in TS 32.295 [54].
- The file based mechanism used to transfer the CDRs from the network to the operator's billing domain (e.g. the billing system or a mediation device) is specified in TS 32.297 [52].
- The services, operations and procedures of charging, using Service Based Interface are specified in TS 32.290 [57].
- The charging service of 5G system is specified in TS 32.291 [58].

All references, abbreviations, terms, descriptions, principles and requirements, used in the present document, that are common across 3GPP TSs, are defined in TR 21.905 [100]. Those that are common across charging management in 3GPP networks/domains, services or subsystems are provided in the umbrella TS 32.240 [1] and are copied into clause 3 of the present document for ease of reading. Finally, those items that are specific to the present document are defined exclusively in the present document.

2 References

The following documents contain provisions which, through reference in this text, constitute provisions of the present document.

- References are either specific (identified by date of publication, edition number, version number, etc.) or non-specific.
- For a specific reference, subsequent revisions do not apply.
- For a non-specific reference, the latest version applies. In the case of a reference to a 3GPP document (including a GSM document), a non-specific reference implicitly refers to the latest version of that document *in the same Release as the present document*.

[1] 3GPP TS 32.240: "Telecommunication management; Charging management; Charging architecture and principles".

[2] - [50]	Void.
[51]	3GPP TS 32.298: "Telecommunication management; Charging management; Charging Data Record (CDR) parameter description".
[52]	3GPP TS 32.297: "Telecommunication management; Charging management; Charging Data Record (CDR) file format and transfer".
[53]	Void.
[54]	3GPP TS 32.295: "Telecommunication management; Charging management; Charging Data Record (CDR) transfer".
[55-56]	Void.
[57]	3GPP TS 32.290: "Telecommunication management; Charging management; 5G system; Services, operations and procedures of charging using Service Based Interface (SBI)".
[58]	3GPP TS 32.291: "Telecommunication management; Charging management; 5G system; Charging service, stage 3".
[59] - [99]	Void.
[100]	3GPP TR 21.905: "Vocabulary for 3GPP Specifications".
[101] - [199]	Void
[200]	3GPP TS 23.501: "System Architecture for the 5G System (5GS)".
[201]	3GPP TS 23.502: "Procedures for the 5G System (5GS)".
[202]	3GPP TS 23.503: "Policy and Charging Control Framework for the 5G System; Stage 2".
[203]	3GPP TS 38.413: "NG-RAN; NG Application Protocol (NGAP)".
[204]	3GPP TS 29.413: "Application of the NG Application Protocol (NGAP) to non-3GPP access".
[205]	3GPP TS 23.256: "Support of Uncrewed Aerial Systems (UAS) connectivity, identification and tracking; Stage 2".
[206]	3GPP TS 24.501: "Non-Access-Stratum (NAS) protocol for 5G System (5GS); Stage 3".
[207] - [299]	Void
[300] - [399]	Void.
[400] - [499]	Void.
[500] - [599]	Void.

3 Definitions of terms, symbols and abbreviations

3.1 Terms

For the purposes of the present document, the terms given in 3GPP TR 21.905 [100] and the following apply. A term defined in the present document takes precedence over the definition of the same term, if any, in 3GPP TR 21.905 [100].

3.2 Symbols

For the purposes of the present document, the following symbols apply:

Bam	Reference point for the CDR file transfer from the 5G connection and mobility CGF to the BD.
Ga	Reference point for CDR transfer between a CDF and the CGF.
Nchf	Service based interface exhibited by CHF.
N41	Reference point between AMF and the -CHF in different PLMNs.
N42	Reference point between AMF and the CHF in the same PLMN.

3.3 Abbreviations

For the purposes of the present document, the abbreviations given in 3GPP TR 21.905 [100] and the following apply. An abbreviation defined in the present document takes precedence over the definition of the same abbreviation, if any, in 3GPP TR 21.905 [100].

5GC	5G Core Network
5GS	5G System
5G-AN	5G Access Network
AMF	Access and Mobility Management Function
B-CHF	Business CHF
BD	Billing Domain
C-CHF	Consumer CHF
CCS	Converged Charging System
CDF	Charging Data Function
CGF	Charging Gateway Function
CHF	Charging Function
CTF	Charging Trigger Function
DNN	Data Network Name
ECUR	Event Charging with Unit Reservation
GPSI	Generic Public Subscription Identifier
H-CHF	A CHF in HPLMN
IEC	Immediate Event Charging
GUAMI	Globally Unique AMF Identifier
MICO	Mobile Initiated Connection Only
N3IWF	Non-3GPP InterWorking Function
NF	Network Function
NRF	Network Repository Function
PEC	Post Event Charging
PEI	Permanent Equipment Identifier
SUPI	Subscription Permanent Identifier
UAS	Uncrewed Aerial System
UAV	Uncrewed Aerial Vehicle
UDM	Unified Data Management
UDR	Unified Data Repository
V-CHF	A CHF in VPLMN

4 Architecture considerations

4.1 High-level 5G System architecture

4.1.1 Non-roaming reference architecture

Figure 4.1.1.1 shows the 5G System high level architecture in the service-based representation, as defined in TS 23.501 [200], with AMF encompassing 5G registration, connection and mobility management functionalities:

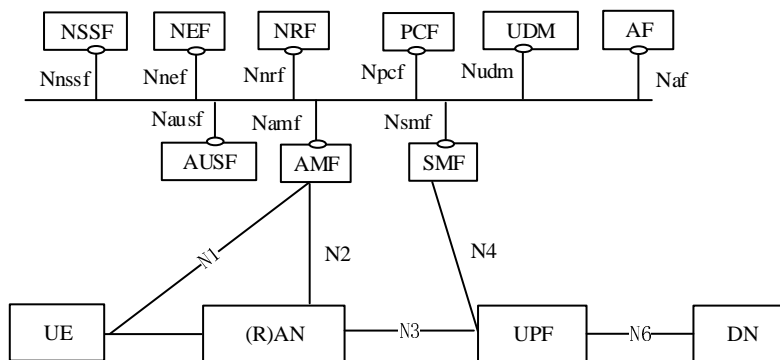

Figure 4.1.1.1: 5G System architecture

4.1.2 Roaming reference architecture

Figure 4.1.2.1 shows the 5G System roaming architecture with local breakout in the service-based representation, as defined in TS 23.501 [200], with AMF encompassing 5G registration, connection and mobility management functionalities:

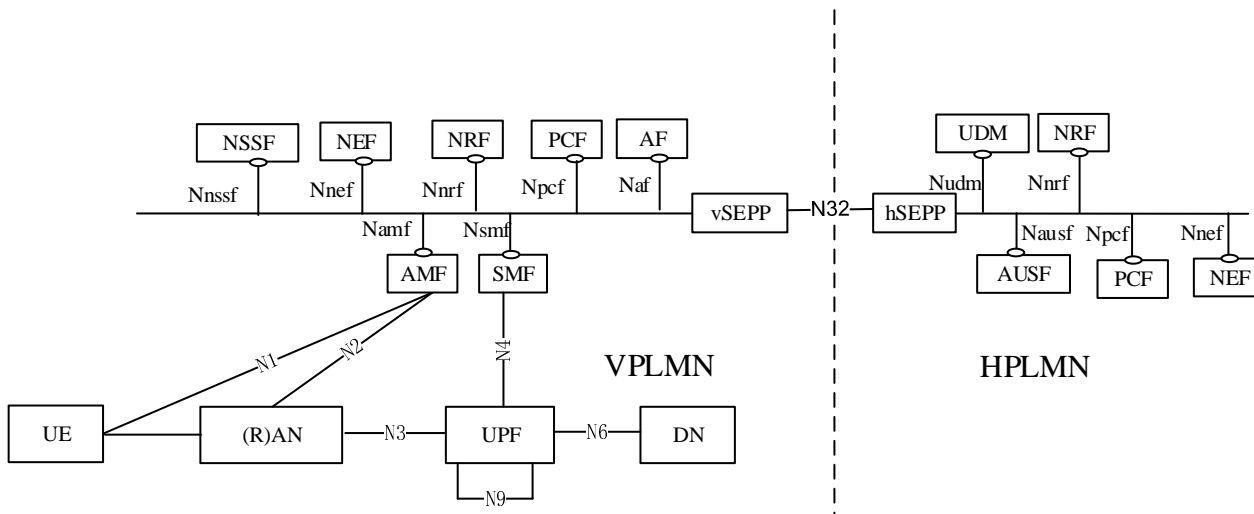

Figure 4.1.2.1: Roaming 5G System architecture- local breakout scenario in service-based interface representation

Figure 4.1.2.2 shows the 5G System roaming architecture in the case of home routed scenario the service-based representation, as defined in TS 23.501 [200], with AMF encompassing 5G registration, connection and mobility management functionalities:

4.2 5G connection and mobility domain converged charging architecture

4.2.1 Non-roaming

Architectural options for 5G connection and mobility converged charging achieved by AMF embedding the CTF, are depicted in figure 4.2.1.1.

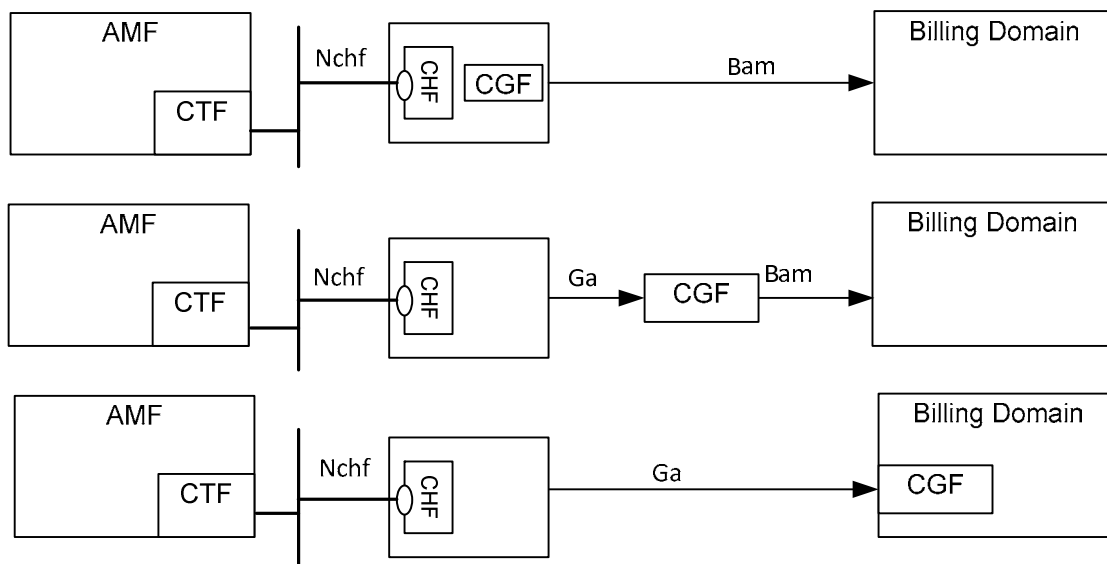

Figure 4.2.1.1: 5G connection and mobility converged charging architecture

Details on the interfaces and functions can be found in TS 32.240 [1] for the general architecture components. Ga is described in clause 5.2.4 and Bam in clause 5.2.5 of the present document, and Nchf is described in TS 32.290 [57].

Figure 4.2.1.2 shows the 5G connection and mobility converged charging architecture in reference point representation for non-roaming:

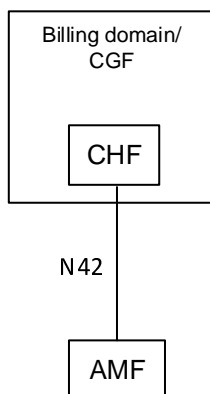

Figure 4.2.1.2: 5G connection and mobility converged charging architecture non-roaming reference point representation

The N42 reference point is defined for the interactions between AMF and CHF.

4.2.2 Roaming

Figure 4.2.2.1 shows the 5G connection and mobility converged charging architecture in roaming service based representation:

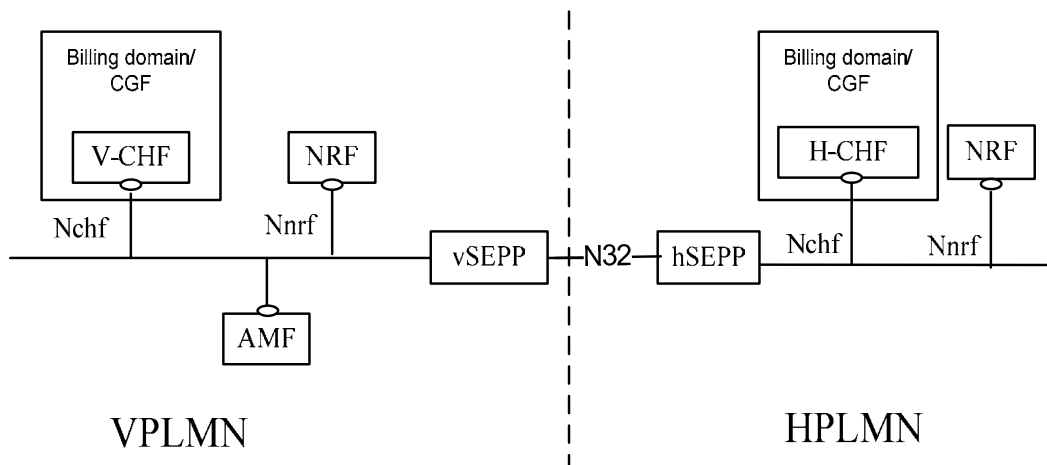

Figure 4.2.2.1: 5G connection and mobility converged charging architecture in roaming

The architectural options of figure 4.2.1.1 apply with AMF located in VPLMN, V-CHF and corresponding Billing domain/CGF located in VPLMN.

The architectural options of figure 4.2.1.1 apply with AMF located in VPLMN, H-CHF and corresponding Billing domain/CGF located HPLMN. The Security Edge Protection Proxy (SEPP) specified in TS 23.501 [200] is used for inter-PLMN Nchf.

Figure 4.2.2.2 shows the 5G connection and mobility converged charging architecture in roaming with AMF to V-CHF and AMF to H-CHF, reference point representation:

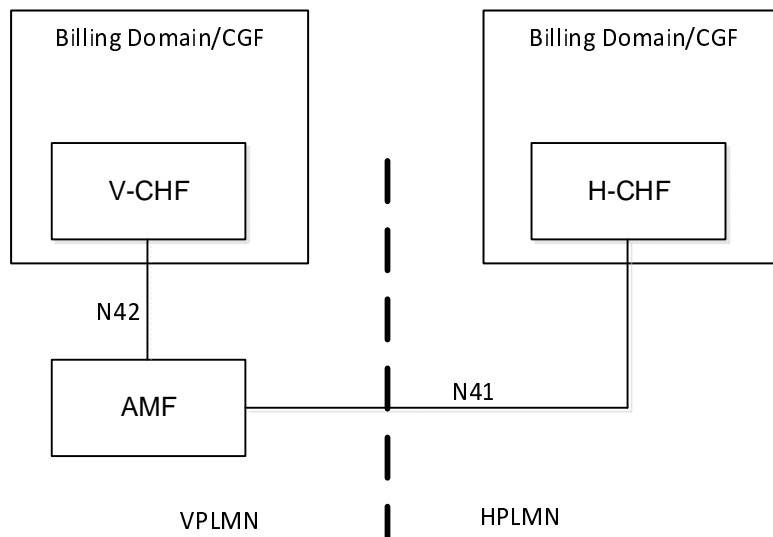

Figure 4.2.2.2: 5G connection and mobility converged charging architecture in roaming with AMF to H-CHF - reference point representation

NOTE: In some scenarios only N42 may be a deployment option based on agreement between HPLMN and VPLMN, in this case the interactions with HPLMN or MVNO is outside the scope of this specification.

The N41 reference point is defined for the interactions between AMF and H-CHF and the N42 reference point is defined for the interactions between AMF and V-CHF.

Figure 4.2.2.3, an alternative to Figure 4.2.2.2, shows the 5G connection and mobility converged charging architecture in roaming, reference point representation:

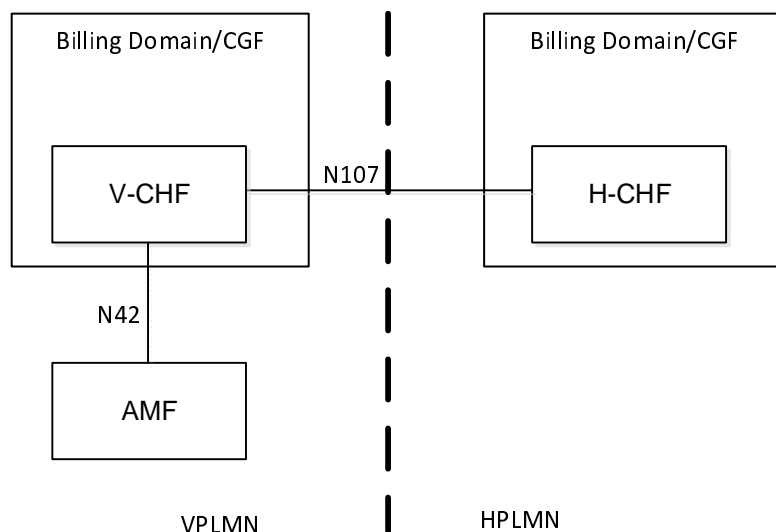

Figure 4.2.2.3: 5G connection and mobility converged charging architecture in roaming with V-CHF to H-CHF - reference point representation

The N42 reference point is defined for the interactions between AMF and V-CHF and the N107 reference point is defined for the interactions between V-CHF and H-CHF.

One or both of the architectures in Figure 4.2.2.2 and Figure 4.2.2.3 may be supported for local breakout roaming.

In case both architectures in Figure 4.2.2.2 and Figure 4.2.2.3 are supported for roaming, AMF and V-CHF determines which architecture should be selected for a roaming UE based on operator agreement.

4.3 5G connection and mobility converged charging Consumer CHF to Business CHF architecture

Figure 4.3-1 depicts the 5G connection and mobility converged charging Consumer CHF to Business CHF architecture in reference point representation:

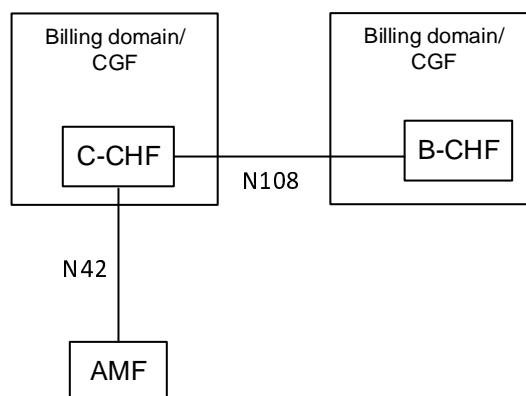

Figure 4.3-1: 5G connection and mobility converged charging architecture Consumer CHF to Business CHF architecture in reference point representation

The N42 reference point is as per Figure 4.2.1.2 of this document.

The N108 reference point is defined for the interactions between C-CHF and B-CHF.

This architecture is used for Network slice converged charging based on 5G connection and mobility: the B-CHF handles the Tenant the Network Slice is assigned to.

5 5G connection and mobility charging principles and scenarios

5.1 5G connection and mobility charging principles

5.1.1 General

The charging functions specified for the 5G connection and mobility charging, are based on functionalities supported by AMF specified in TS 23.501 [200]:

- Registration Management;
- Connection Management;
- Location Reporting.

Location Reporting is applicable to NG-RAN only.

5.1.2 Requirements

The following are high-level charging requirements specific to the 5G connection and mobility charging:

- The AMF shall support converged online and offline charging using service based interface.
- The AMF shall collect charging information per UE registration to the 5GS.
- The AMF shall collect charging information per UE N2 connection between the 5G-AN and the AMF.
- The AMF shall collect charging information per UE location reporting.
- The AMF may collect charging information including CAG Identifier(s) per UE registration to the 5GS.

- The AMF may collect charging information including Network Identifier per UE registration to the 5GS.
- In roaming scenario, the AMF shall collect charging information per in-bound roamer UE registration in 5GS, for both V-PLMN and Home PLMN.

5.1.3 CHF selection

The CHF Address(es) selection by the AMF is done during the Registration process, this selection may be based on the following options and with priority order depending on Operator's policies:

- CHF Address(es) used for UE context transferred from old AMF.
- CHF address(es) provided by the PCF as part of Access and mobility policy control information.
- UDM provided charging characteristics.
- NRF based discovery (Applicable for CHF selection by another CHF as well)
- Locally provisioned charging characteristics (Applicable for CHF selection by another CHF as well)

The UDM provided charging characteristics (see annex A) may be used to indicate CHF instance ID(s), CHF set ID(s), CHF Group .

The CHF instance ID(s), CHF set ID(s), CHF Group ID can be used for the and that NRF based CHF discovery, ID see TS 32.290 [57] clause 6.1.

Once selected, these CHF Address(es) shall be used as long as the UE is registered in the AMF.

5.1.4 UE Presence in Presence Reporting Area (PRA)

At UE initial registration, the CHF may subscribe to a list of Presence Reporting Area(s), to be reported with "Change of UE presence in Presence Reporting Area(s)" from AMF.

A Presence Reporting Area, as specified in TS 23.501 [200] clause 5.6.11, may represent:

- A Core Network pre-configured Presence Reporting Area identified by a PRA Identifier;
- A UE-dedicated Presence Reporting Area defined by CHF and identified by a PRA Identifier with its elements (i.e. list of TAs and/or NG-RAN nodes and/or cells identifiers).

The CHF remains subscribed to the list of Presence Reporting Area(s) as long as the UE is registered in the AMF until the list is updated or unsubscribed-to by subsequent exchanges between the AMF and the CHF.

This functionality is detailed in clause 5.2.1.3.

5.1.5 Roaming

5.1.5.1 General

Based on roaming agreements between the VPLMN and the HPLMN, for each UE determined as in-bound roamer, the AMF in VPLMN shall be able to collect charging information per UE registration, and interact with a V-CHF for CDR generation in VPLMN.

In addition, for this registration, the AMF in VPLMN may be able to interact with a H-CHF for CDR generation in HPLMN.

In the case of disaster roaming with minimization of service interruption service in this case there will be no connection to the H-CHF in HPLMN and only a connection with V-CHF in VPLMN.

5.1.5.2 CHF selection

H-CHF selection by the AMF, during the Registration process when UE determined as in-bound roamer, priority is operator dependent:

- UDM provided charging characteristics.
- NRF based discovery.
- AMF locally provisioned.

V-CHF selection by the AMF with roaming architecture according to figure 4.2.2.2, during the Registration process when UE determined as in-bound roamer, priority is operator dependent:

- NRF based discovery.
- AMF locally provisioned.

H-CHF selection by the V-CHF with roaming architecture according to figure 4.2.2.3, during the Registration process when UE determined as in-bound roamer, priority is operator dependent:

- NRF based discovery.
- CHF locally provisioned.

5.2 5G connection and mobility converged online and offline charging scenarios

5.2.1 Basic principles

5.2.1.1 General

5G connection and mobility converged charging, when activated, may be performed by the AMF interacting with CHF using Nchf specified in TS 32.290 [57] and TS 32.291 [58]. In order to provide the data required for the management activities outlined in TS 32.240 [1] (Credit-Control, accounting, billing, statistics, etc.), the AMF shall be able to perform converged charging for each of the following:

- Charging data related to registration.
- Charging data related to N2 connection between the AN and the AMF.
- Charging data related to user location.

The AMF shall use the AMF charging profile defined in clause 5.2.1.2. The default AMF charging profile is provided by Charging Characteristics applicable to AMF are described in Annex A.

The AMF shall be able to perform converged charging by interacting with CHF, for charging data related to registration, connection and location management. The Charging Data Request and Charging Data Response are exchanged between the AMF and the CHF, based on IEC, PEC or ECUR scenarios as specified in TS 32.290 [57]. The Charging Data Request is issued by the AMF towards the CHF when certain conditions (chargeable events) are met.

The contents and purpose of each charging event that triggers interaction with CHF, as well as the chargeable events that trigger them, are described in the following clauses.

A detailed formal description of the converged charging parameters defined in the present document is to be found in TS 32.291 [58].

A detailed formal description of the CDR parameters defined in the present document is to be found in TS 32.298 [51].

5.2.1.2 Applicable Triggers in the AMF

5.2.1.2.1 General

When a charging event is issued towards the CHF, it includes details such as Subscriber identifier (e.g. SUPI).

Each trigger condition (i.e. chargeable event) defined for the 5G connection and mobility converged charging functionality, is specified with the associated behaviour when they are met.

Table 5.2.1.2.1.1 summarizes the set of default trigger conditions and their category which shall be supported by the AMF when charging is active for the corresponding AMF functionality. For "immediate report" category, the table also provides the corresponding Charging Data Request message sent from AMF towards the CHF.

Table 5.2.1.2.1.1: Default Trigger conditions in AMF

Trigger Conditions	Trigger level	Default category	CHF allowed to change category	CHF allowed to enable and disable	Message when "immediate reporting" category
Registration					
Registration checked	-	Immediate	Not Applicable	Not Applicable Yes	IEC: Charging Data Request [Event] ECUR: Charging Data Request [Initial]
Registration completed	-	Immediate	Not Applicable	Not Applicable Yes	PEC: Charging Data Request [Event] ECUR: Charging Data Request [Termination]
Deregistration	-	Immediate	Not Applicable	Not Applicable	PEC: Charging Data Request [Event]
N2 connection					
Start of N2 connection	-	Immediate	Not Applicable	Not Applicable Yes	PEC: Charging Data Request [Event]
End of N2 connection	-	Immediate	Not Applicable	Not Applicable Yes	PEC: Charging Data Request [Event]
Location reporting					
User Location change	-	Immediate	Not Applicable	Not Applicable Yes	PEC: Charging Data Request [Event]
Change of UE presence in Presence Reporting Area(s)	-	Immediate	Not Applicable	Not Applicable Yes	PEC: Charging Data Request [Event]

AMF functionality charging activation/deactivation is performed by CHF via AMF charging profile update as defined in clause 5.2.1.2.3.

The AMF charging profile is defined in clause 5.2.1.2.2 and shall be used by the AMF to determine whether converged charging is active or not, and which scenario is applicable when active.

During UE initial registration in the AMF, if registration charging is active in the Charging Characteristics, a Charging Data Request [Event, Registration] or Charging Data Request [Initial, Registration] shall be sent to CHF in the corresponding charging scenario (i.e. IEC, PEC or ECUR) when applicable triggers are met. At N2 connection, if N2 connection charging is active in the AMF charging profile, a Charging Data Request [Event, N2 connection] shall be sent to CHF in PEC scenario when applicable triggers are met.

At N2 connection, if location reporting charging is active in the AMF charging profile, the AMF shall start the location reporting control procedure towards NG-RAN specified in clause 4.10 of TS 23.502 [202] for a continuous reporting whenever the UE location changes. A Charging Data Request [Event, location reporting] shall be sent by AMF upon receiving the location report from NG-RAN with current UE location.

If the AMF receives in a Charging Data Response [Event/Initial] from CHF, an updated AMF charging profile deactivating location reporting charging, and the AMF has a N2 connection, the AMF shall cancel the location reporting control procedure towards NG-RAN.

5.2.1.2.2 AMF Charging profile

An AMF charging profile is defined to allow AMF determination of applicable trigger conditions for each functionality (i.e Registration, N2 connection, Location Reporting), and includes:

- charging active or inactive;

- IEC, ECUR or PEC scenario.

For location reporting charging it includes in addition, the level for location change to be reported (i.e. TAI change and/or Cell Change), or UE presence in Presence Reporting Area(s) to be reported. The UE Presence in Presence Reporting Area (PRA) functionality is detailed in clause 5.2.1.3.

IEC and ECUR scenarios are applicable for registration only.

The AMF charging profile is per UE and per AMF.

The default AMF charging profile is provided by the Charging Characteristics which is described in Annex A.

5.2.1.2.3 Independent triggers activation/deactivation

During the UE registration lifetime in the AMF, the CHF may activate/deactivate charging for any AMF functionality (i.e. Registration, N2 connection, Location Reporting) each time the CHF is invoked for a given AMF functionality. The set of triggers enabled/disabled via charging activation/deactivation by CHF are independent from the invoked AMF functionality. The triggers activation/deactivation take effect at the next AMF functionality invoking the CHF.

Table 5.2.1.2.3.1 describes the applicable messages for CHF to activate/deactivate triggers via update of AMF Charging profile:

Table 5.2.1.2.3.1: AMF charging profile update by CHF

Functionality	AMF Charging Profile field which can be updated	Message from CHF to AMF
Registration	- charging "active or inactive"	Charging Data Response [Event/Initial/Termination]
N2 connection	- charging "active or inactive"	Charging Data Response [Event/Initial/Termination]
Location Reporting	- charging "active or inactive" - level for location - list of Presence Reporting Area(s)	Charging Data Response [Event/Initial/Termination]

In ECUR scenario, any update of AMF Charging Profile received in Charging Data Response [Initial] will take effect after the corresponding Charging Data Response [Termination].

5.2.1.3 UE Presence in Presence Reporting Area (PRA)

At UE initial registration in the AMF, the CHF may subscribe to changes of UE presence status(es) in PRA(s) in the Charging Data Response [Event, Registration] or Charging Data Response [Initial, Registration] respective IEC or ECUR scenarios. This subscription is performed, by activation of location reporting charging in the AMF charging profile with a list of PRAs supplied in addition.

The PRAs list may be composed of:

- Core Network pre-configured Presence Reporting Area(s) identified by PRA Identifier(s);
- UE-dedicated Presence Reporting Area(s) defined by a PRA Identifier(s) each provided with its elements.

Once location reporting charging is activated, the registration is completed, the AMF starts the location reporting procedure towards to NG-RAN specified in clause 4.10 of TS 23.502 [202] with parameters associated to the PRA(s), as described in clause 5.2.2.4.2.

When a Change of UE presence in Presence Reporting Area(s) is detected for PRA(s) subscribed-to by the CHF, the AMF sends Charging Data Request [Event, location reporting] to CHF with the PRA Identifier(s) and indication(s) whether the UE is inside or outside the Presence Reporting Area(s).

The CHF may update the list of Presence Reporting Area(s) subscription or remove the list of Presence Reporting Area(s), in any Charging Data Response [Event/Initial] as per table 5.2.1.2.3.1.

5.2.1.4 NR REDCAP Charging

The AMF provides for NR RedCap UE using NR the RAT Type NR_REDCAP, according to clause 5.41 of TS 23.501 [200].

5.2.1.5 PNI-NPN Charging

A Public Network Integrated NPN (PNI-NPN), i.e. a non-public network deployed with the support of a PLMN, is specified in clause 5.30.3 of TS 23.501 [200]. End user charging for PNI-NPN network usage of access is based on registration management charging in AMF.

The AMF can collect charging information including CAG Identifier(s) per UE registration to the 5GS, if available, and sends it to CHF. The CAG information of the UE is included in the subscription as part of the Mobility Restrictions as defined in clause 5.30.3 of TS 23.501 [200]:

- an Allowed CAG list i.e. a list of CAG Identifiers the UE is allowed to access; and
- optionally, a CAG-only indication whether the UE is only allowed to access 5GS via CAG cells.

The charging information collected by AMF can also be S-NSSAI or dedicated DNNs, or dedicated DNN and S-NSSAI combination.

5.2.1.6 SNPN Charging

A Stand-alone Non-Public Network (SNPN), i.e. operated by an NPN operator and not relying on network functions provided by a PLMN, is specified in clause 5.30.2 of TS 23.501 [200].

End user charging for SNPN network usage of access is based on registration management charging in AMF. The AMF collects charging information including SNPN ID (PLMN ID and NID identifying an SNPN) per UE registration to the 5GS.

5.2.1.7 Support for satellite access charging

The AMF determines and reports the RAT type for NR satellite access (i.e. NR(LEO), NR(MEO), NR(GEO) and NR(OTHERSAT)) and the user location including NR NTN TAI information.

The AMF may initiate Network-initiated Deregistration if it detects that the UE's registered PLMN is not allowed to operate in the present UE location.

If N2 Context Release Request cause indicates the release is requested due to a UE using satellite access moved out of PLMN serving area, the AMF may deregister the UE, described in clause 5.2.2.2.8 Network-initiated Deregistration before continuing with the AN Release procedure in Figure 5.2.2.3.4.1.

For 5G non-roaming Mobile Virtual Network Operators (MVNOs) which consume satellite access service, the charging information including the RAT type for NR satellite access may be reported to host operator CHF.

5.2.1.8 UAS Charging

The 5GS support of Uncrewed Aerial Systems (UAS) connectivity, identification and tracking is specified in TS 23.256 [205]. The Uncrewed Aerial Vehicle (UAV) is a 3GPP UE supporting the UE functionality and is configured for UAS services provisioned with a single CAA (Civil Aviation Administration)-Level UAV Identity.

According to clause 5.2 of TS 23.256 [205], AMF can receive the Uncrewed Aerial Vehicle (UAV) information (e.g. CAA-Level UAV ID) during the UAV Authentication and Authorization procedure and can identify the specific type of the UAV. The charging information collected by AMF may include the UAV information per UE registration to the 5GS.

5.2.2 Message flows

5.2.2.1 General

The flows in the present document specify the interaction between the AMF and the CHF for 5G connection and mobility converged charging functionality, in different scenarios, based on TS 23.501 [200] and TS 23.502 [201] procedures and flows.

This interaction is based on Charging Data Request /Response specified in TS 32.290 [57], exchanged between the AMF embedding the CTF and the CHF.

As a general principle, the steps in the figures for the message flows below correspond to the steps of figures in TS 23.502 [202], which is the reference. The present document specifies the charging specific extension part.

5.2.2.2 Registration management charging from AMF

5.2.2.2.1 General

The subclause below describes registration management charging.

For registration procedures, the following scenarios specified in TS 32.290 [57] are supported:

- PEC;
- IEC;
- ECUR.

For deregistration procedures, only PEC scenario is supported.

5.2.2.2.2 General Registration – PEC charging

The following figure 5.2.2.2.2.1 describes a Registration charging message flow in PEC charging, based on figure 4.2.2.2.2-1 of TS 23.502 [202] description and, applicable to:

- Initial Registration in 5GS;
- Mobility Registration Update; or
- Periodic Registration Update; or
- Emergency Registration.

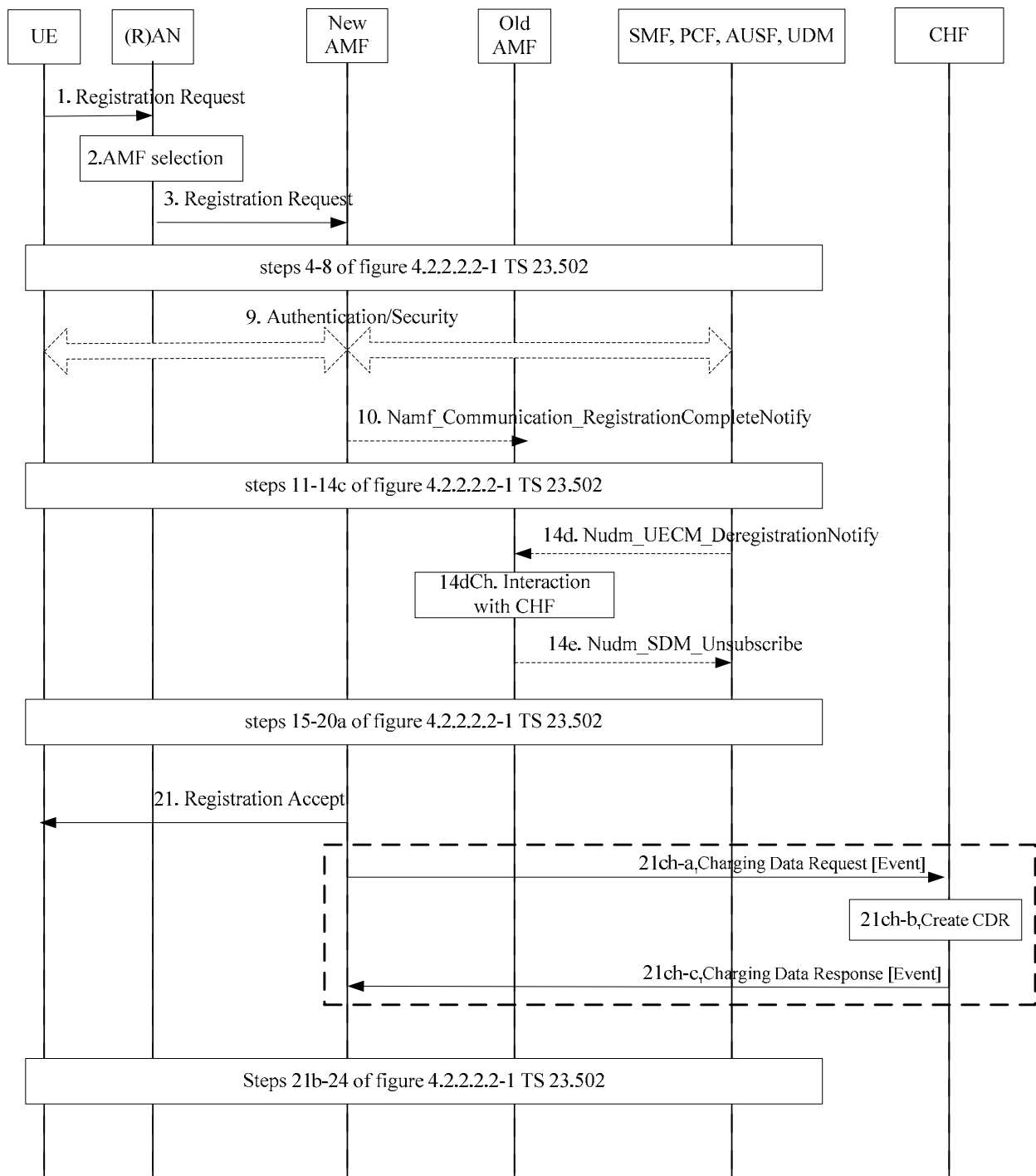

Figure 5.2.2.2.1: Registration – PEC charging

1-14c. Registration procedure initiated by UE.

10: The new AMF notifies the old AMF that the registration of the UE in the new AMF is completed.

14d: If necessary, the old AMF is requested by UDM to delete Registration Management contexts and PDU Sessions.

14dCh: The old AMF interacts with the CHF as per deregistration procedure described in figure 5.2.2.2.8.1.

21. Upon successful procedure, Registration Accept sent to the UE.

21ch-a. The AMF sends Charging Data Request [Event] to CHF for the UE successful registration.

21ch-b. The CHF creates the CDR for this registration.

21ch-c. The CHF acknowledges by sending Charging Data Response [Event] to the AMF.

5.2.2.2.3 General Registration – IEC

The following figure 5.2.2.2.3.1 describes a Registration charging message flows in IEC, based on the clause 5.2.2.2.2 Registration description:

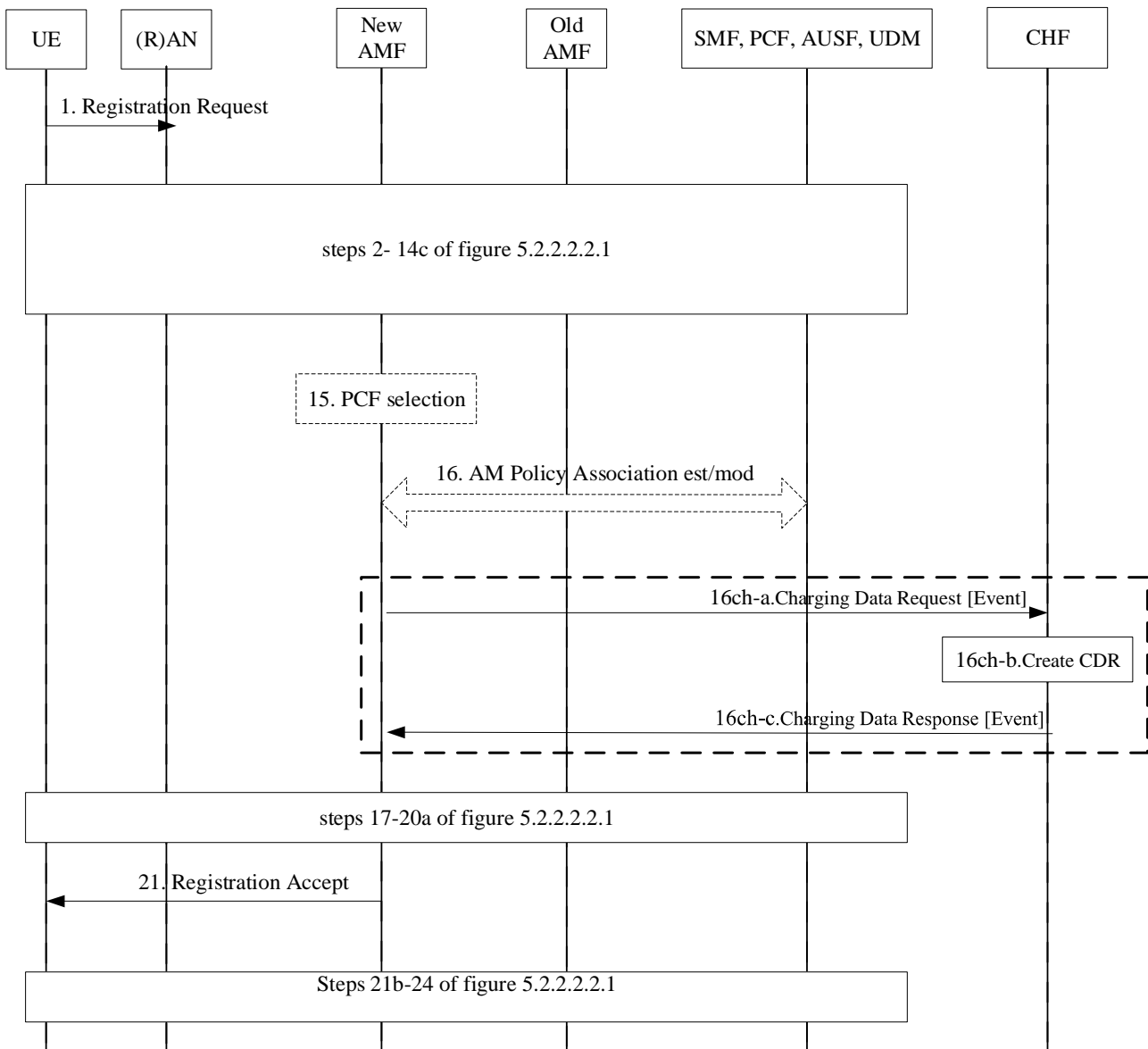

Figure 5.2.2.2.3.1: Registration – IEC

1-14c. Registration procedure initiated by UE.

15-16: AM policy association procedure.

16ch-a. The AMF sends Charging Data Request [Event] to CHF for the UE registration to be granted authorization, rated and accounted.

16ch-b. Account and Rating control by the CHF for the registration and CDR creation.

16ch-c. The CHF acknowledges by sending Charging Data Response [Event] and the AMF, granting authorization to the registration.

17 to 24. Same steps as in Figure 5.2.2.2.2.1.

5.2.2.2.4 General Registration – ECUR

The following figure 5.2.2.2.4.1 describes a Registration charging message flows in ECUR, based on the clause 5.2.2.2.2 Registration description:

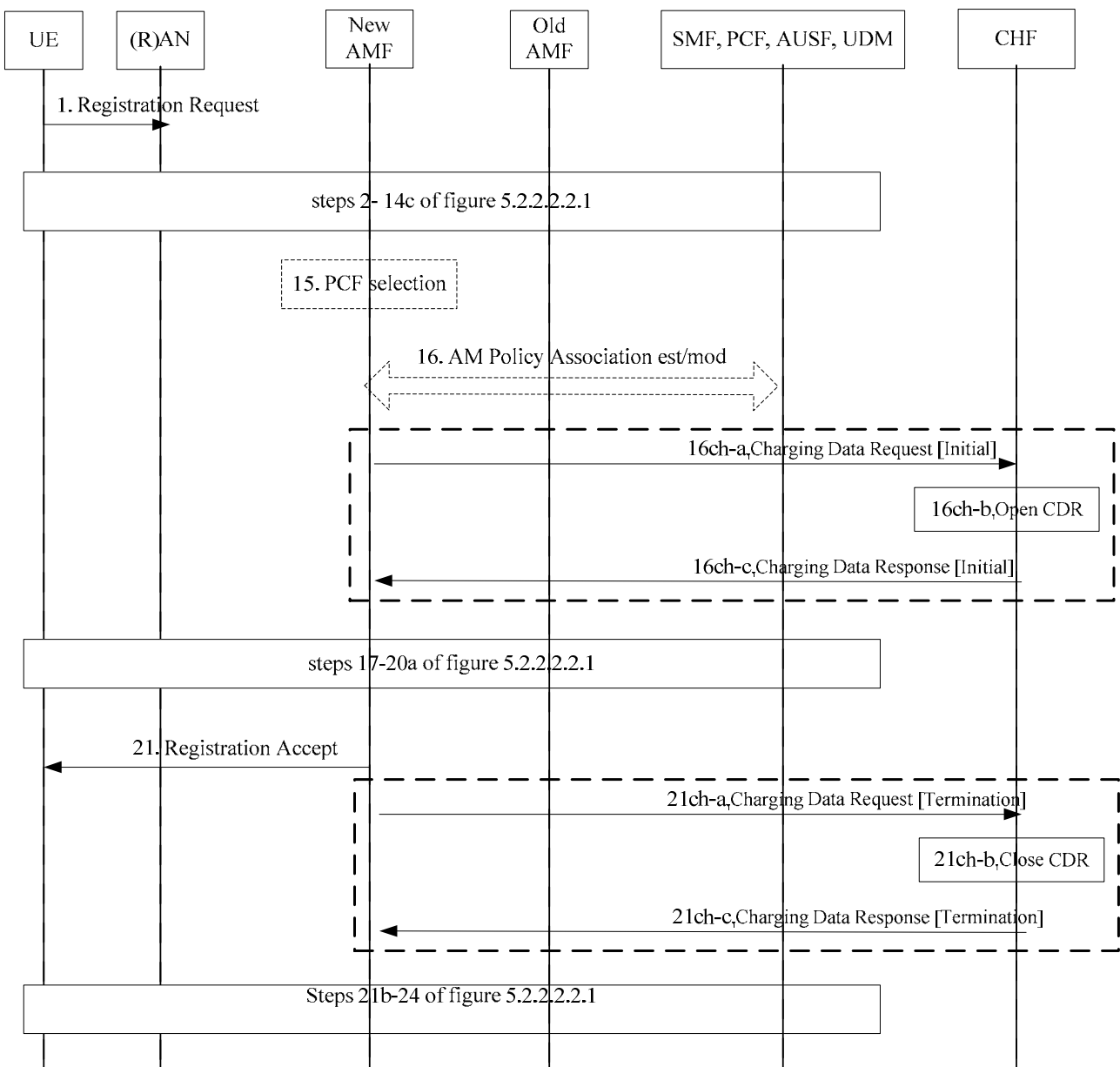

Figure 5.2.2.2.4.1: Registration – ECUR

1-14c. Registration procedure initiated by UE.

15-16: AM policy association procedure.

16ch-a. The AMF sends Charging Data Request [Initial] to CHF for the UE registration to be granted authorization.

16ch-b. Account and Rating control by the CHF for the registration and open a CDR.

16ch-c. The CHF acknowledges by sending Charging Data Response [Initial] and the AMF, granting authorization to the registration.

17 to 21. Same steps as in Figure 5.2.2.2.1.

21ch-a. The AMF sends Charging Data Request [Termination] to CHF for the UE successful registration.

21ch-b. The CHF closes the CDR for this registration.

21ch-c. The CHF acknowledges by sending Charging Data Response [Termination] to the AMF.

5.2.2.2.5 Registration with AMF re-allocation – PEC charging

The following figure 5.2.2.2.5.1 describes a registration with AMF re-allocation PEC charging, based on figure 4.2.2.2.3-1 TS 23.502 [202] description:

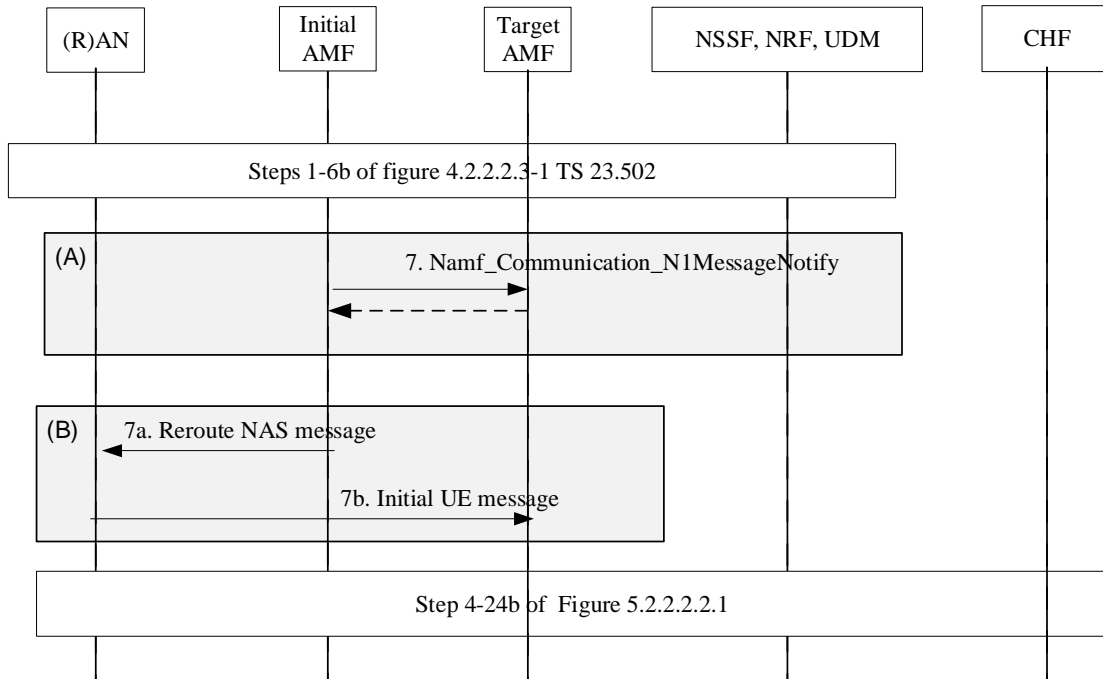

Figure 5.2.2.2.5.1: Registration with AMF re-allocation– PEC charging

1-7b. Registration with AMF re-allocation procedure.

21ch-a to 21ch-c: same steps as per Figure 5.2.2.2.1.

4-24b. Registration procedure in PEC charging in clause 5.2.2.2.2.

5.2.2.2.6 Registration with AMF re-allocation – IEC

AMF re-allocation IEC charging is described by the figure 5.2.2.2.5.1 with the Registration procedure in steps 4-24b. referring to IEC charging in clause 5.2.2.2.3.

5.2.2.2.7 Registration with AMF re-allocation – ECUR

AMF re-allocation IEC charging is described by the figure 5.2.2.2.5.1 with the Registration procedure in steps 4-24b. referring to ECUR charging in clause 5.2.2.2.4.

5.2.2.2.8 Deregistration – PEC charging

The Deregistration message flows are applicable to:

- UE-initiated deregistration
- Network-initiated Deregistration.

The following figure 5.2.2.2.8.1 describes a UE-initiated deregistration in PEC charging, based on figure 4.2.2.3.2-1 of TS 23.502 [202] description:

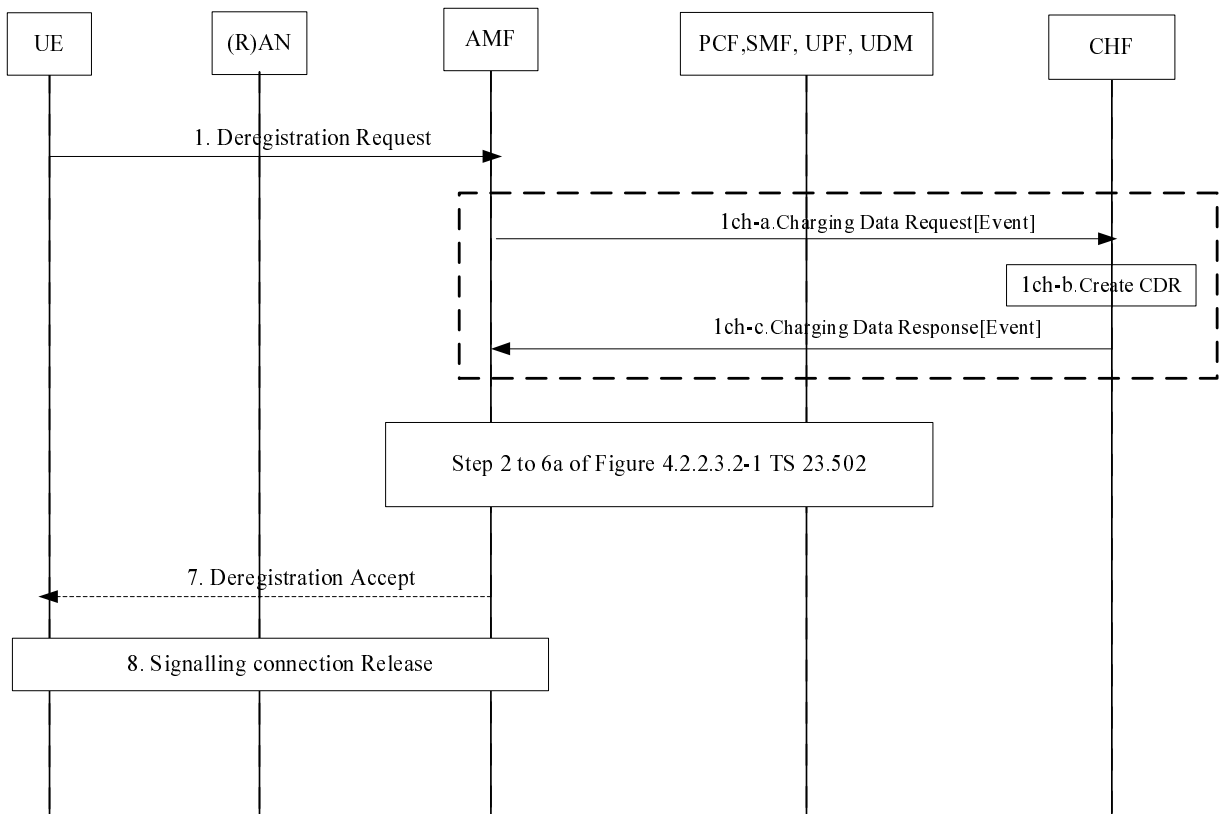

Figure 5.2.2.8.1: UE-initiated Deregistration – PEC charging

1. Deregistration procedure initiated by UE.

1ch-a. The AMF sends Charging Data Request [Event] to CHF for the UE deregistration.

1ch-b. The CHF creates the CDR for this deregistration.

1ch-c. The CHF acknowledges by sending Charging Data Response [Event] to the AMF.

7: The AMF sends NAS message Deregistration Accept to UE. In case of Deregistration type is switch-off, the Deregistration Accept message is not sent.

The following figure 5.2.2.8.2 describes a Network-initiated Deregistration in PEC charging, based on figure 4.2.2.3.3-1 of TS 23.502 [202] description:

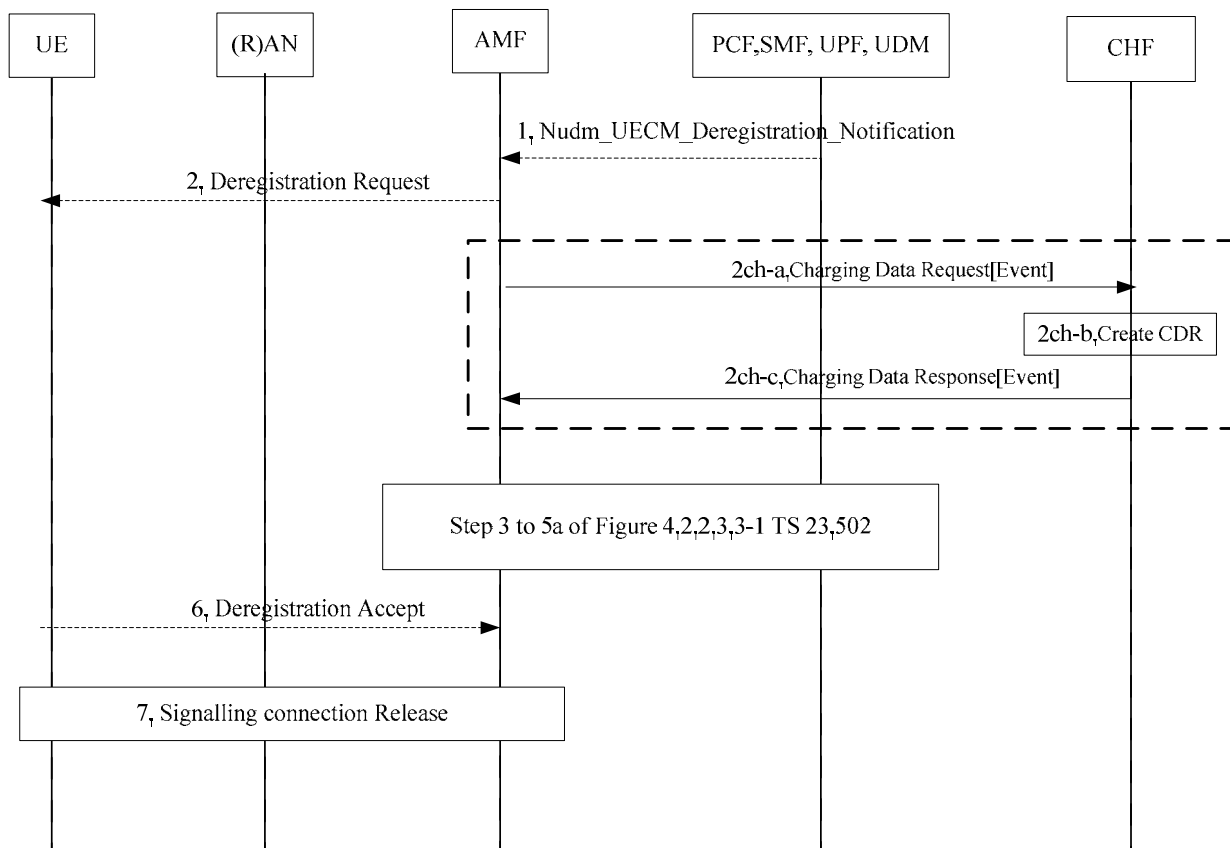

Figure 5.2.2.8.2: Network-initiated Deregistration – PEC charging

- 1. AMF receives Nudm_UECM_DeregistrationNotification from UDM.
- 2. Deregistration Request sent towards the UE. In case of Implicit Deregistration, the Deregistration Request message is not sent.
- 2ch-a. The AMF sends Charging Data Request [Event] to CHF for the UE successful deregistration.
- 2ch-b. The CHF creates the CDR for this deregistration.
- 2ch-c. The CHF acknowledges by sending Charging Data Response [Event] to the AMF.
- [3-8]. Deregistration procedure steps.

5.2.2.2.9 Registration – Untrusted non-3GPP access - PEC charging

The following figure 5.2.2.2.9.1 describes UE Registration via Untrusted non-3GPP Access, in PEC charging, based on figure 4.12.2.2-1 of TS 23.502 [202] description.

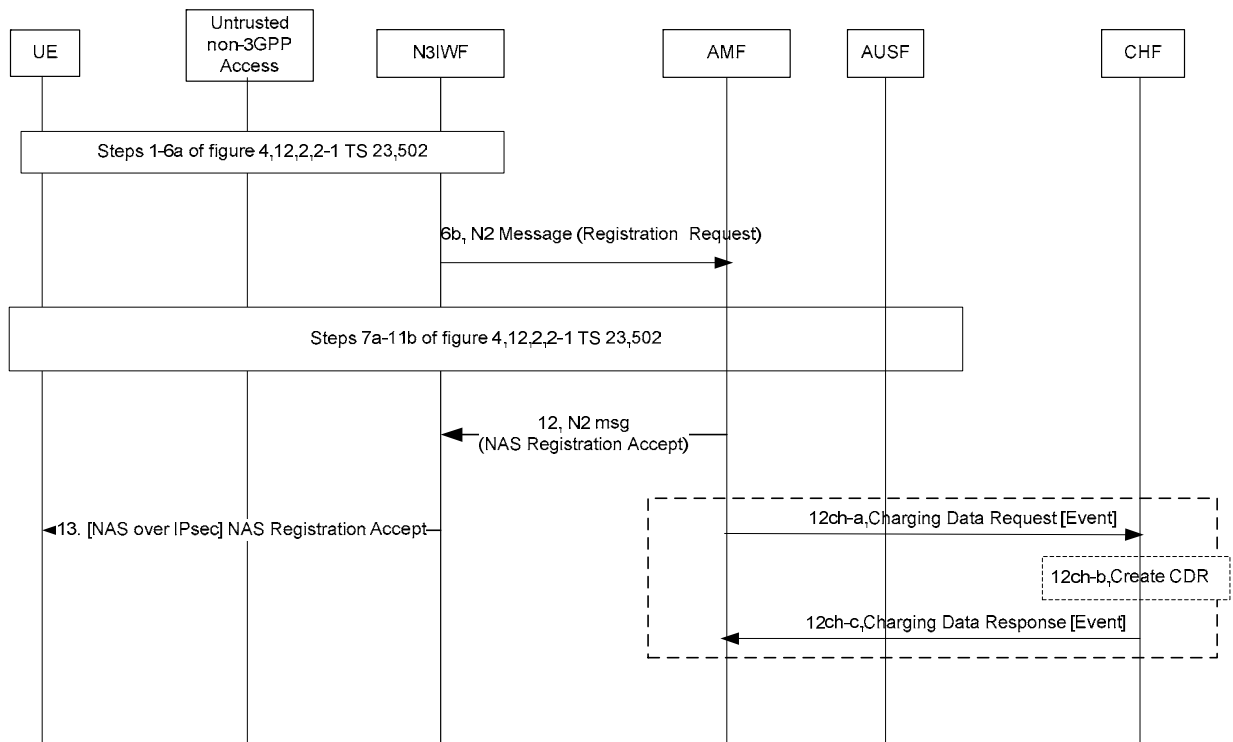

Figure 5.2.2.2.9.1: Registration via Untrusted non-3GPP Access – PEC

1-11b. UE registration procedure via N3IWF.

12. Upon successful procedure, NAS Registration Accept sent to N3IWF by AMF.

12ch-a. The AMF sends Charging Data Request [Event] to CHF for the UE successful registration.

12ch-b. The CHF creates the CDR for this registration.

12ch-c. The CHF acknowledges by sending Charging Data Response [Event] to the AMF.

5.2.2.2.10 Registration – Untrusted non-3GPP access - IEC

The following figure 5.2.2.2.10.1 describes UE Registration via Untrusted non-3GPP Access in IEC, based on figure 4.12.2.2-1 of TS 23.502 [202] description.

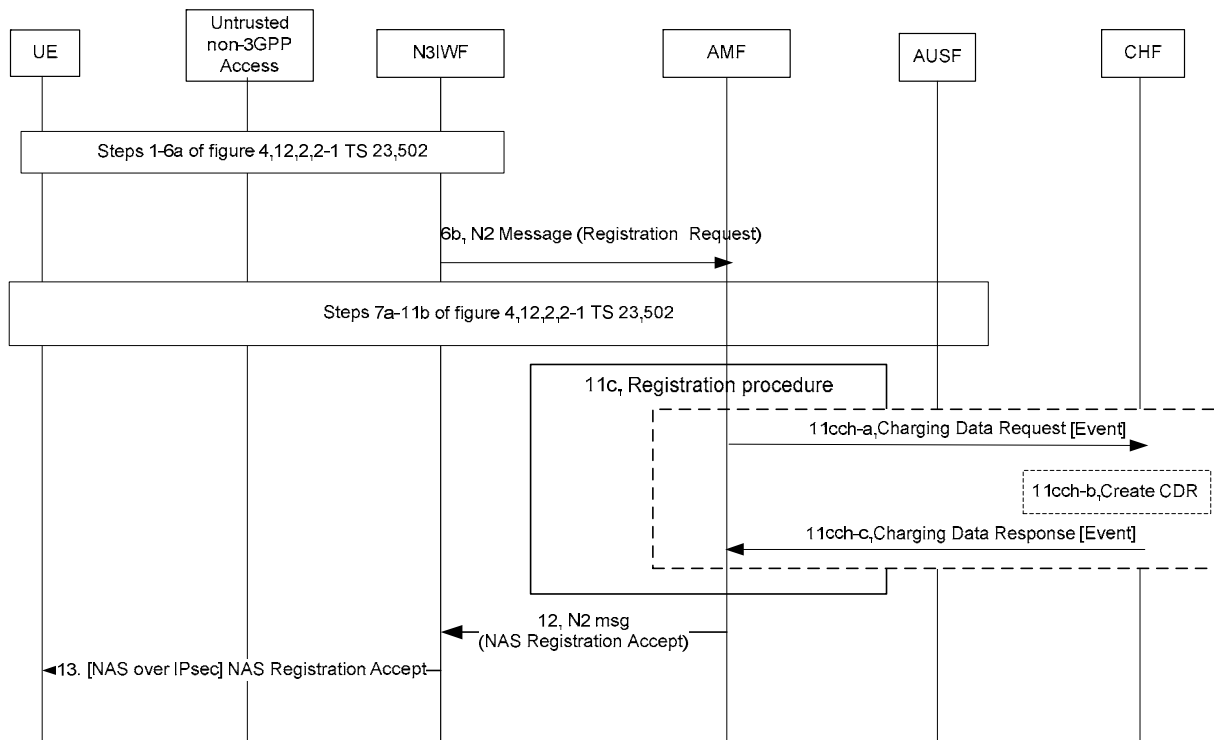

Figure 5.2.2.2.10.1: Registration via Untrusted non-3GPP Access – IEC

1-11b. UE registration procedure via N3IWF.

11c. Registration procedure in IEC with AMF interactions with PCF, UDM, as specified in clause 5.2.2.2.3.

11cch-a. to 11cch-c. Same steps as 16ch-a to 16ch-c of Figure 5.2.2.2.3.1.

5.2.2.2.11 Registration – Untrusted non-3GPP access - ECUR

The following figure 5.2.2.2.11.1 describes UE Registration via Untrusted non-3GPP Access in ECUR, based on figure 4.12.2.2-1 of TS 23.502 [202] description.

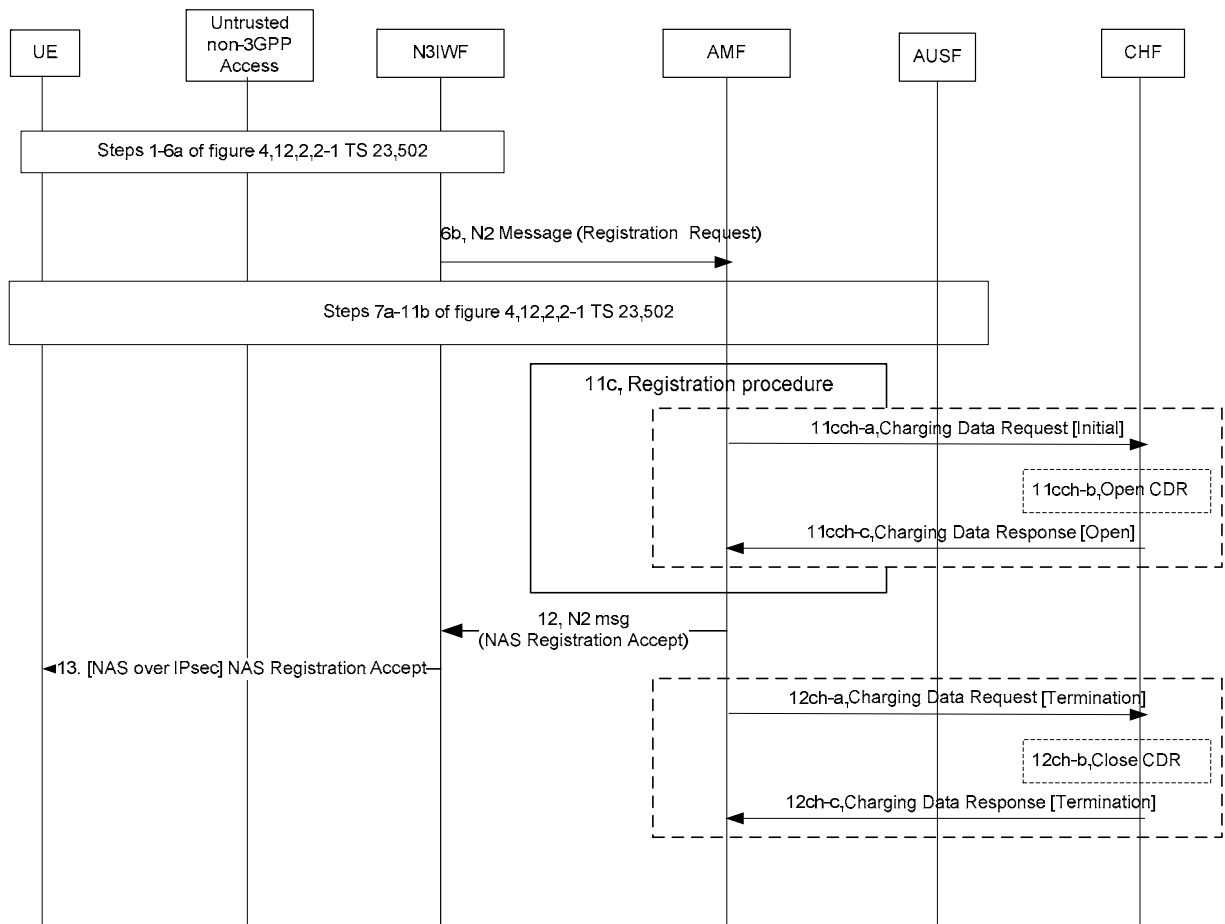

Figure 5.2.2.2.11.1: Registration via Untrusted non-3GPP Access – ECUR

1-11b. UE registration procedure via N3IWF.

11c. Registration procedure with AMF interactions with PCF, UDM, as specified in clause 5.2.2.2.3.

11ch-a. to 11ch-c. Same steps as 16ch-a to 16ch-c of Figure 5.2.2.2.4.1.

12ch-a. to 12ch-c. Same steps as 21ch-a to 21ch-c of Figure 5.2.2.2.4.1.

5.2.2.2.12 Registration for SMS over NAS – PEC charging

The following figure 5.2.2.2.12.1 describes a registration in 5GS for SMS over NAS in PEC charging, based on figure 4.13.3.1-1 TS 23.502 [202], where the "SMS supported" indication is included in Registration Request from the UE.

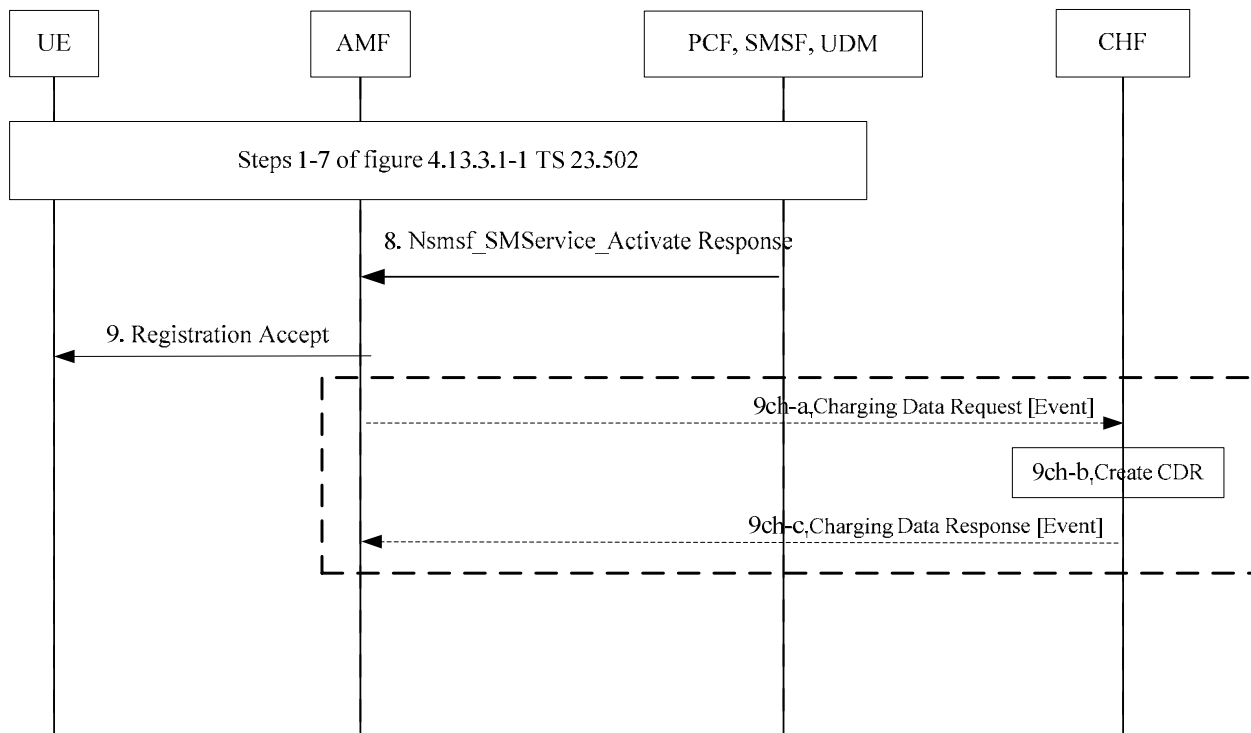

Figure 5.2.2.2.12.1: Registration for SMS over NAS – PEC charging

Steps 1-7: SMS service activation in the SMSF

Step 8: SMSF answers to the AMF with Nsmsf_SMSservice_Activate service

9ch-a to 9ch-c: Same steps as 21ch-a to 21ch-c of Figure 5.2.2.2.1. The "SMS allowed" indication is included in addition.

5.2.2.2.13 Registration for SMS over NAS – IEC

The following figure 5.2.2.2.13.1 describes a registration in 5GS for SMS over NAS in IEC, based on clause 5.2.2.2.12.

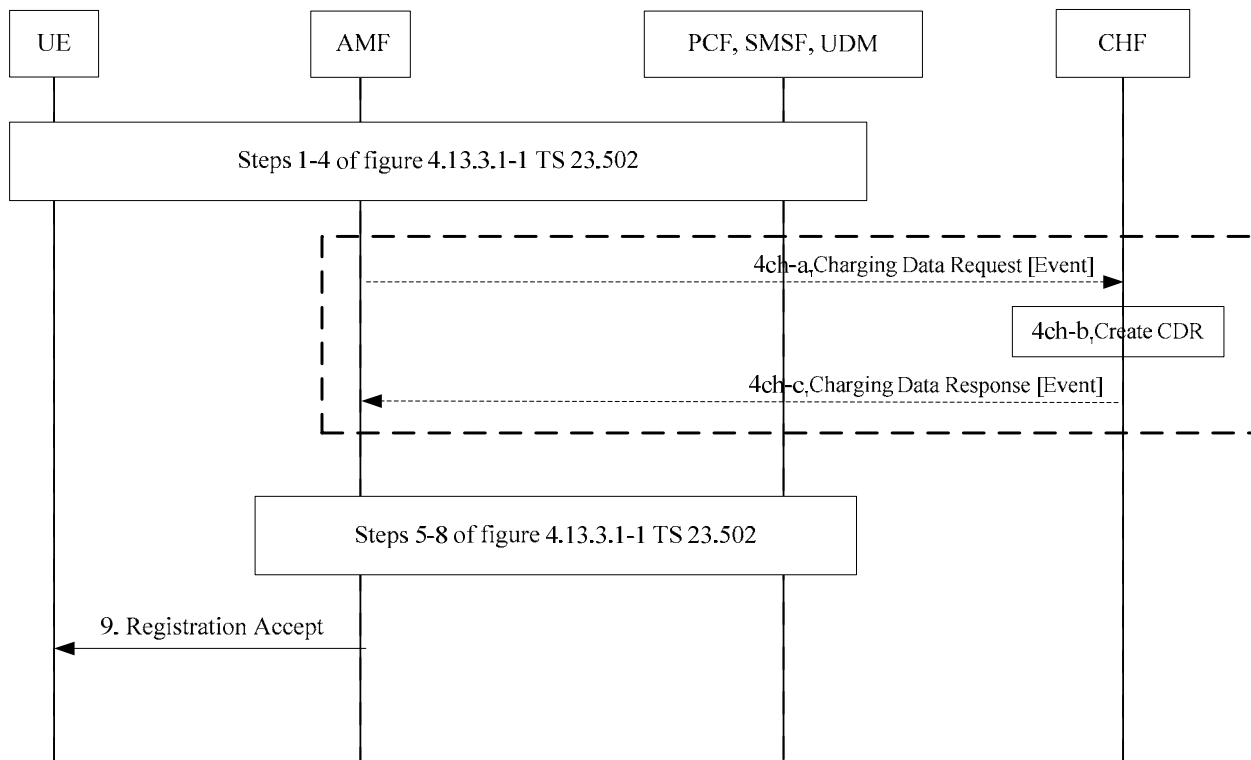

Figure 5.2.2.2.13.1: Registration for SMS over NAS – IEC

Steps 1-4: UE Registration for SMS.

4ch-a to 4ch-c: Same steps as 16ch-a to 16ch-c of Figure 5.2.2.2.1. The "SMS allowed" indication is included.

Step 5-9: Registration for SMS procedure

5.2.2.2.14 Registration for SMS over NAS – ECUR

The following figure 5.2.2.2.14.1 describes a registration in 5GS for SMS over NAS in ECUR, based on clause 5.2.2.2.12.

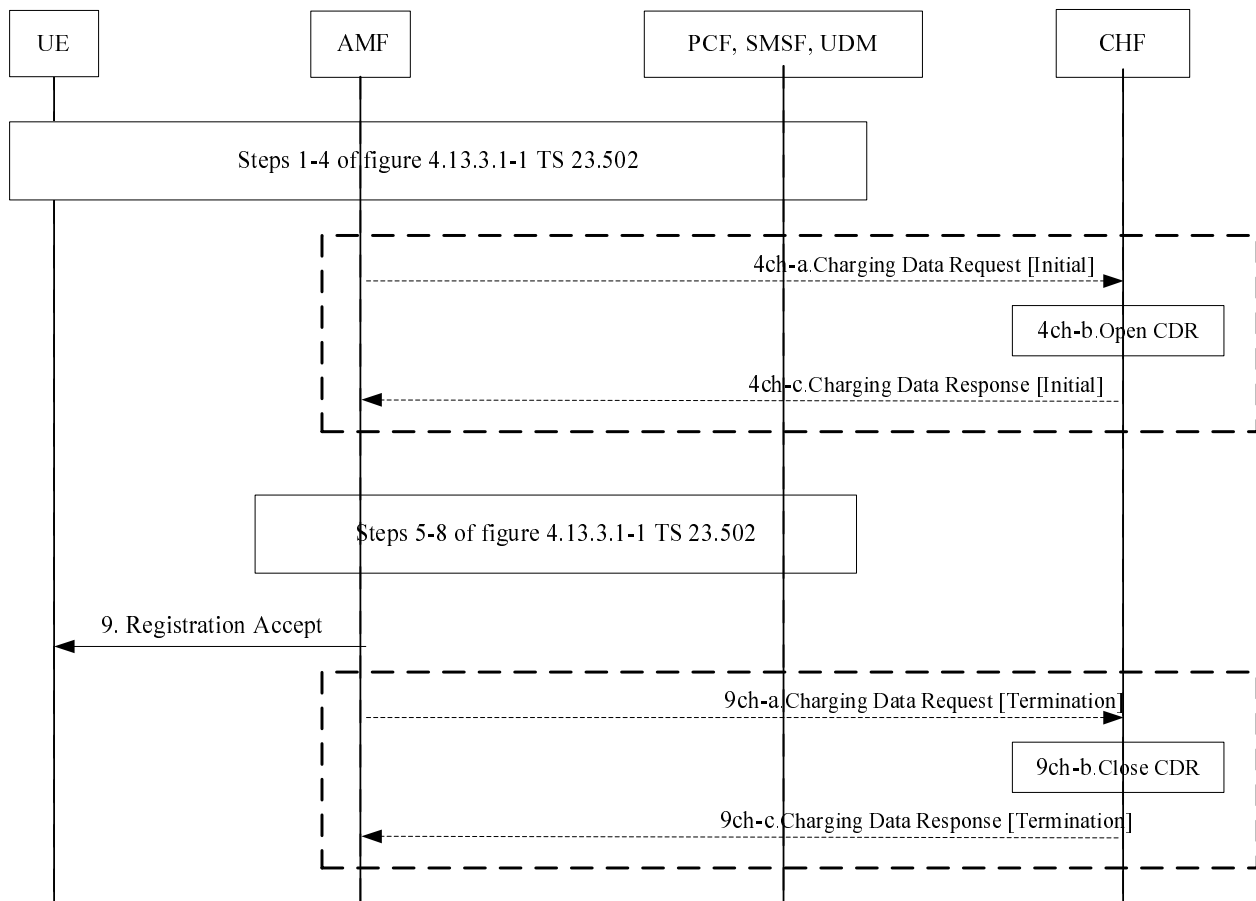

Figure 5.2.2.2.14.1: Registration for SMS over NAS – ECUR

Steps 1-4: UE Registration for SMS.

4ch-a to 4ch-c: Same steps as 16ch-a to 16ch-c of Figure 5.2.2.2.4.1. The "SMS allowed" indication is included.

Step 5-9: Registration for SMS procedure

9ch-a to 9ch-c: Same steps as 21ch-a to 21ch-c of Figure 5.2.2.2.4.1.

5.2.2.2.15 Deregistration for SMS over NAS – PEC charging

Deregistration procedures for SMS over NAS are specified in TS 23.502 [202] clause 4.13.3.2:

- When based on subsequent Registration Request message from the UE, the registration charging scenario in clause 5.2.2.2.2 or 5.2.2.2.3 applies.
- When based on procedures in which UE is determined as deregistered by the AMF, the Network-initiated deregistration charging scenario in clause 5.2.2.2.8 applies.

5.2.2.3 Connection management charging from AMF

5.2.2.3.1 General

The clause below describes connection management charging, which includes:

- N2 connection for this UE between the AN and the AMF for 3GPP access and untrusted non-3GPP access.

The TS 23.502 [201] service request procedures and flows are used to describe one of the N2 connection establishment cases. The procedures for N2 connection establishment are specified in TS 38.413 [203] for 3GPP access and

exceptions in TS 29.413 [204] for untrusted non-3GPP, under the establishment of UE-associated logical NG-connection.

5.2.2.3.2 UE Triggered Service Request

The following figure 5.2.2.3.2.1 describes UE N2 connection during UE Triggered Service Request, in event based offline charging, based on figure 4.2.3.2-1 of TS 23.502 [202] description.

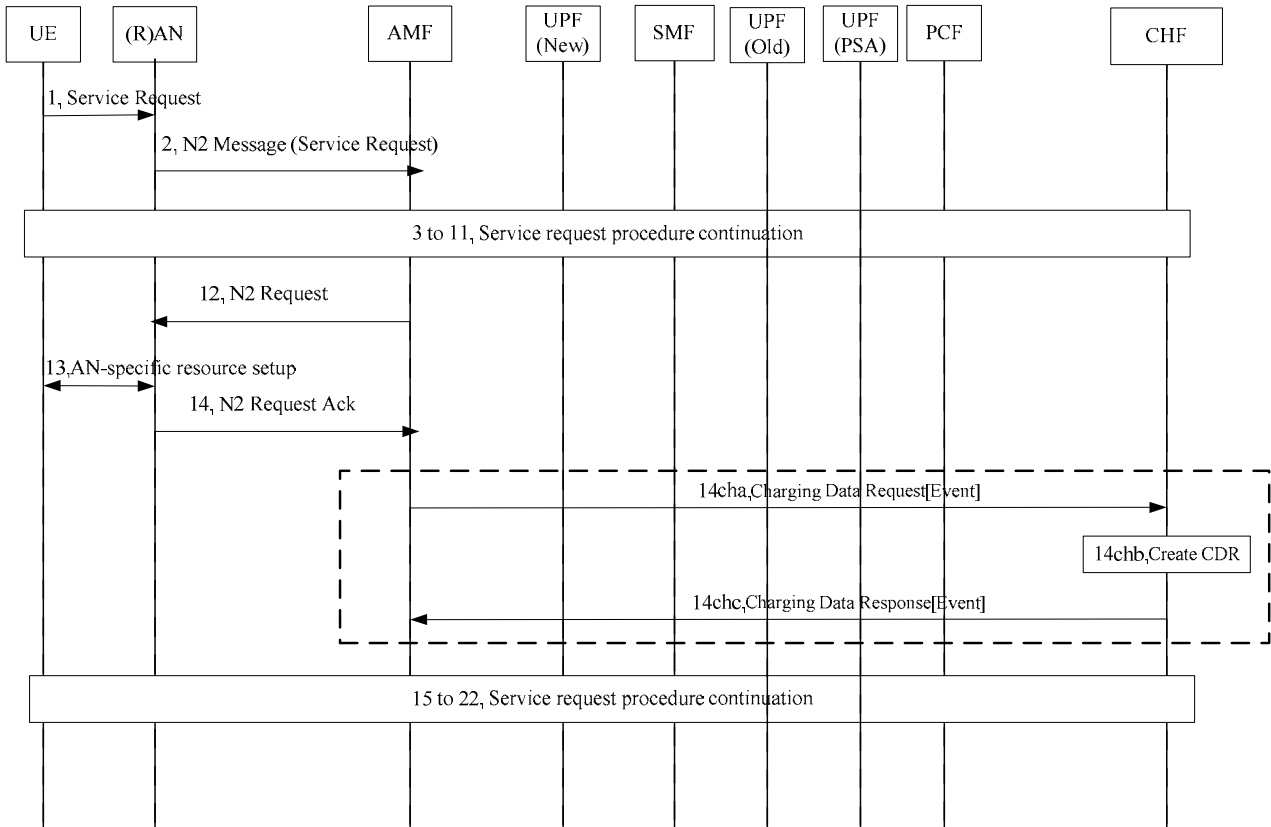

Figure 5.2.2.3.2.1: UE Triggered Service Request –PEC charging

1-13. Service request procedure initiated by UE.

14. The (R)AN sends N2 Request ACK to AMF.

14ch-a. The AMF sends Charging Data Request [Event] to CHF for the N2 connection established for the UE.

14ch-b. The CHF creates the CDR for this N2 connection establishment.

14ch-c. The CHF acknowledges by sending Charging Data Response [Event] to the AMF.

15-22. Service request procedure continuation.

In case of untrusted non-3GPP, the (R)AN corresponds to an N3IWF, and the figure 4.2.3.2-1 of TS 23.502 [202] description applies with the exceptions specified in clause 4.12.4.1 of TS 23.502 [202].

5.2.2.3.3 Network Triggered Service Request

Based on figure 4.2.3.3-1 of TS 23.502 [202] description, a Service Request procedure from the UE is triggered from the Network, and corresponding N2 connection event offline charging in clause 5.2.2.3.2 applies.

5.2.2.3.4 AN release

The following figure 5.2.2.3.4.1 describes UE N2 connection release in event based offline charging, based on figure 4.2.6-1 of TS 23.502 [202] description.

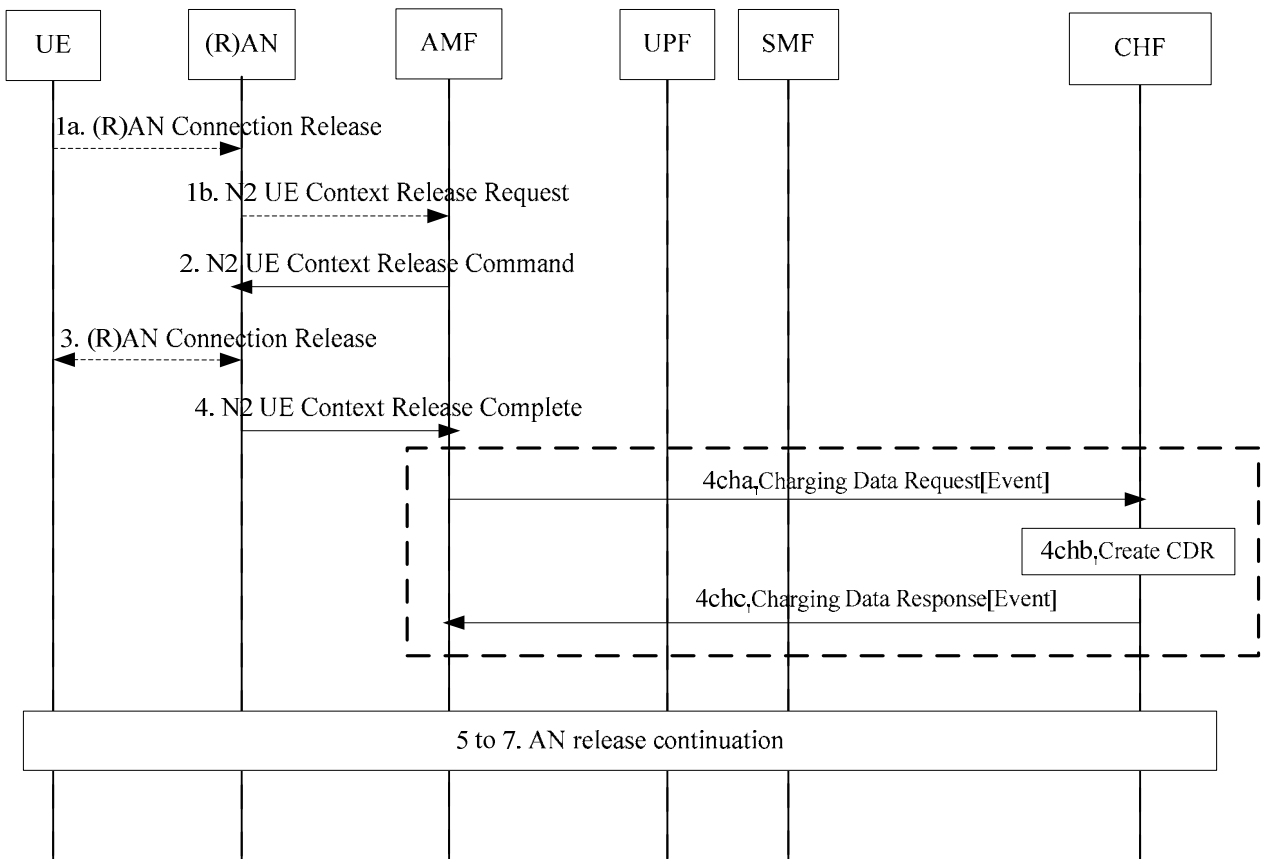

Figure 5.2.2.3.4.1: AN release –PEC charging

1a-3. Release initiated by the (R)AN.

4. The AMF receives an N2 UE Context Release Complete.

4ch-a. The AMF sends Charging Data Request [Event] to CHF for the UE N2 connection release.

4ch-b. The CHF creates the CDR for this N2 connection release.

4ch-c. The CHF acknowledges by sending Charging Data Response [Event] to the AMF.

5-7. AN release procedure continuation.

In case of untrusted non-3GPP, the procedure is specified in figure 4.12.4.2-1 of TS 23.502 [202], and the figure 5.2.2.3.4.1 applies with following differences:

- (R)AN corresponds to an N3IWF.
- step 1a is replaced by conditions in figure 4.12.4.2-1 of TS 23.502 [202]

5.2.2.4 Location reporting charging

5.2.2.4.1 General

The clause below describes location reporting charging.

5.2.2.4.2 Location reporting

The following figure 5.2.2.4.2.1 describes Location reporting charging, in Post Event Charging.

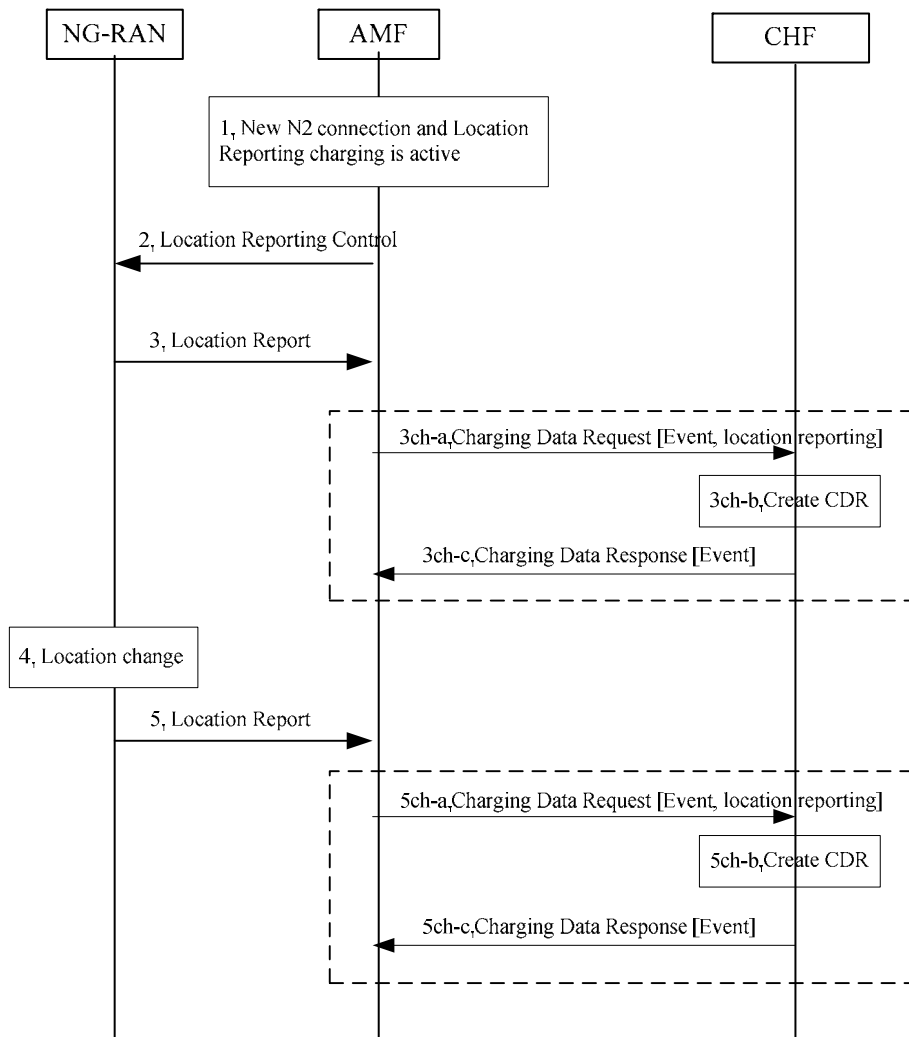

Figure 5.2.2.4.2.1: Location reporting – Post Event Charging

1. A New N2 connection is established between NG-RAN and AMF and Location Reporting charging is activated in the AMF charging profile, potentially with a list of Presence Reporting Area(s).
2. The AMF starts the procedure based on figure 4.10-1 of TS 23.502 [202] description and sends "Location Reporting Control" to NG-RAN indicating UE changes of location or presence in Presence Reporting Area(s) need to be reported.
3. Location Report received by AMF includes the UE current location, and potentially presence in Presence Reporting Area(s).
- 3ch-a. The AMF sends Charging Data Request [Event, location reporting] to CHF with the current user location, and initial status(es) of presence in subscribed PRA(s) if requested in step 1.
- 3ch-b. The CHF creates the CDR for this location reporting.
- 3ch-c. The CHF acknowledges by sending Charging Data Response [Event, location reporting] to the AMF.
4. Change in UE Location or presence in Presence Reporting Area(s) occur per AMF criteria provided in step 2.
5. Location Report is received by AMF.
- 5ch-a. The AMF sends Charging Data Request [Event, location reporting] to CHF with the new user location, and PRA Identifier(s) and indication(s) whether the UE is inside or outside the Presence Reporting Area(s) if any.
- 5ch-b. The CHF creates the CDR for this location reporting.
- 5ch-c. The CHF acknowledges by sending Charging Data Response [Event, location reporting] to the AMF.

5.2.2.5 Roaming - Registration management charging from AMF

5.2.2.5.1 General

In roaming, for registration management charging, the AMF in VPLMN:

- shall support PEC scenario with V-CHF.
- may support IEC or ECUR scenario with V-CHF.
- may support PEC, IEC or ECUR scenario with H-CHF.

In roaming, for registration management charging, the V-CHF:

- may support PEC, IEC or ECUR scenario with H-CHF.

The architecture in figure 4.2.2.2 is applicable for flows in figures 5.2.2.5.2.1, 5.2.2.5.3.1, and 5.2.2.5.4.1, and architecture in figure 4.2.2.3 is applicable for flows in figures 5.2.2.5.6.1, 5.2.2.5.7.1, 5.2.2.5.8.1, and 5.2.2.5.9.1

5.2.2.5.2 Registration - PEC to HPLMN and AMF to H-CHF and V-CHF

The following figure 5.2.2.5.2.1 describes a Registration charging message flow in PEC to HPLMN scenario for roaming, based on figure 4.2.2.2.2-1 of TS 23.502 [201], where the AMF interacts with H-CHF and V-CHF.

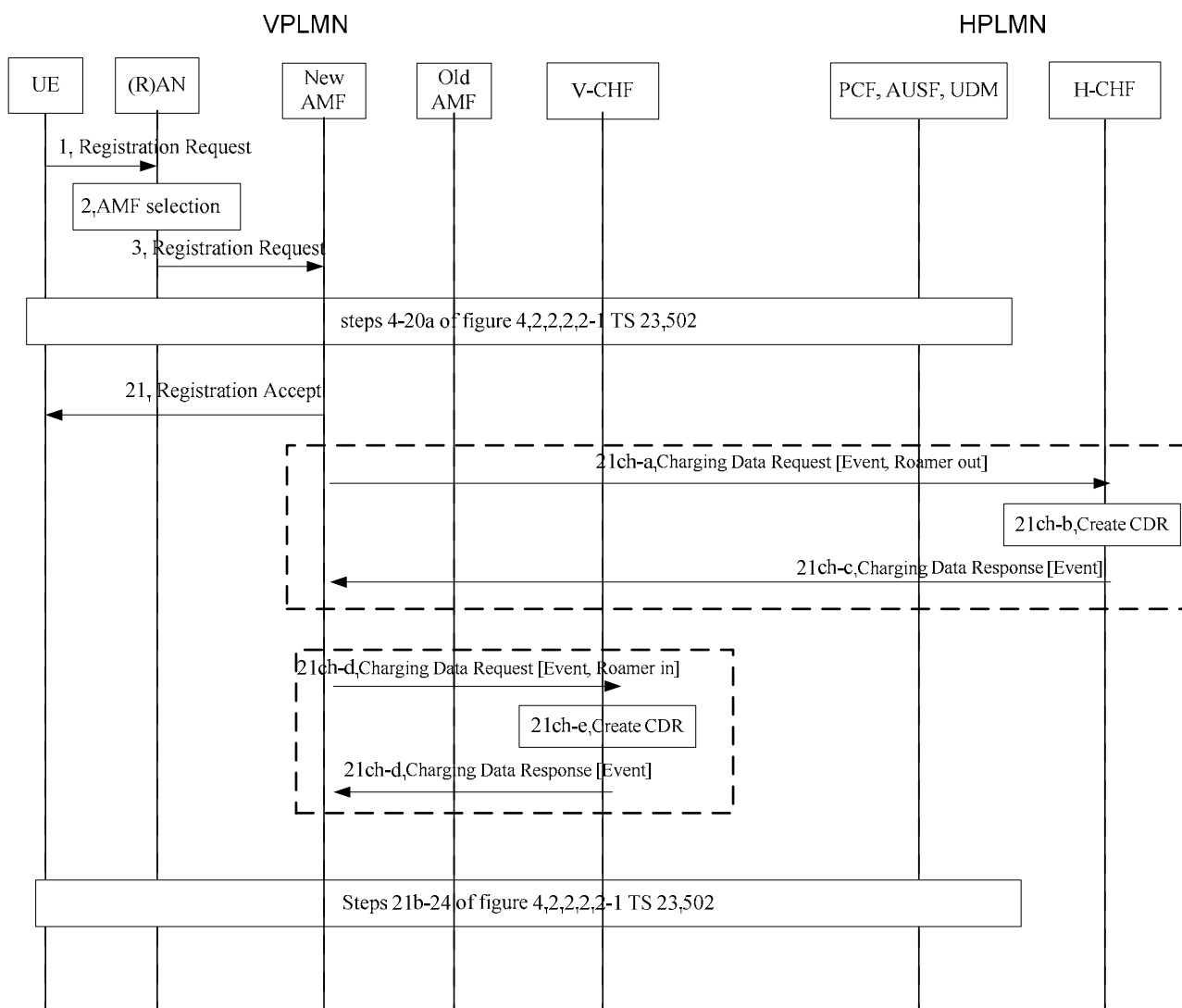

Figure 5.2.2.5.2.1: Roaming Registration – PEC to HPLMN and AMF to H-CHF and V-CHF

1-20a. Registration procedure initiated by UE per steps 1 to 20a of figure 4.2.2.2.2-1 of TS 23.502 [201], with PCF, AUSF and UDM in HPLMN.

21. Upon successful procedure, Registration Accept sent to the UE.

21ch-a. Upon Registration completed trigger, the AMF in VPLMN may send Charging Data Request [Event] to H-CHF for the UE successful registration, indicating "roamer out".

21ch-b. The H-CHF creates the CDR for this registration.

21ch-c. The H-CHF acknowledges by sending Charging Data Response [Event] to the AMF in VPLMN.

21ch-d. The AMF in VPLMN sends Charging Data Request [Event] to the V-CHF for the UE successful registration, indicating "roamer in".

21ch-e. The V-CHF creates the CDR for this registration.

21ch-f. The V-CHF acknowledges by sending Charging Data Response [Event] to the AMF in VPLMN.

21b-24. Registration procedure continues as per steps 21b to 24 of figure 4.2.2.2.2-1 of TS 23.502 [201].

5.2.2.5.3 Registration – IEC to HPLMN and AMF to H-CHF and V-CHF

The following figure 5.2.2.5.3.1 describes a Registration charging message flows in IEC to HPLMN scenario for roaming, based on the clause 5.2.2.2.2, where the AMF interacts with H-CHF and V-CHF.

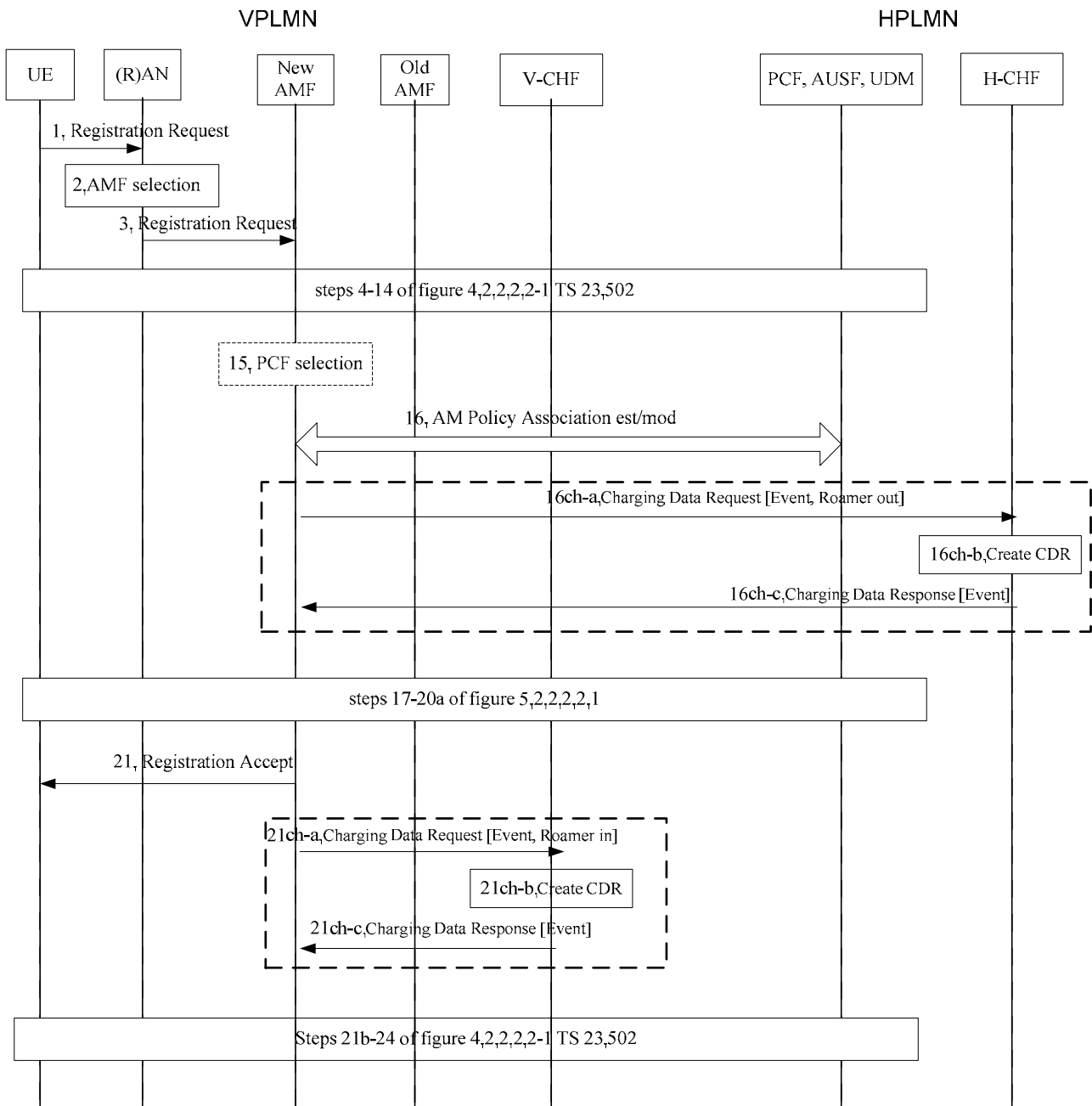

Figure 5.2.2.5.3.1: Roaming Registration – IEC to HPLMN and AMF to H-CHF and V-CHF

1-16. Registration procedure initiated by UE per steps 1 to 16 of figure 4.2.2.2-1 of TS 23.502 [201], with PCF, AUSF and UDM in HPLMN.

16ch-a. Upon Registration checked trigger, the AMF in VPLMN sends Charging Data Request [Event] to H-CHF for the UE registration to be granted authorization, rated and accounted, indicating "roamer out".

16ch-b. Accounting and Rating control by the H-CHF for the registration and CDR creation.

16ch-c. The H-CHF acknowledges by sending Charging Data Response [Event] to the AMF in VPLMN, granting authorization to the registration.

21ch-a. Upon Registration completed trigger, the AMF in VPLMN sends Charging Data Request [Event] to V-CHF for the UE successful registration, indicating "roamer in".

21ch-b. The V-CHF creates the CDR for this registration.

21ch-c. The V-CHF acknowledges by sending Charging Data Response [Event] to the AMF in VPLMN.

17 to 24. Same steps as in Figure 5.2.2.2.1.

5.2.2.5.4 Registration – ECUR to HPLMN and AMF to H-CHF and V-CHF

The following figure 5.2.2.5.4.1 describes a Registration charging message flows in ECUR to HPLMN scenario for roaming, based on the clause 5.2.2.2.2, where the AMF interacts with H-CHF and V-CHF.

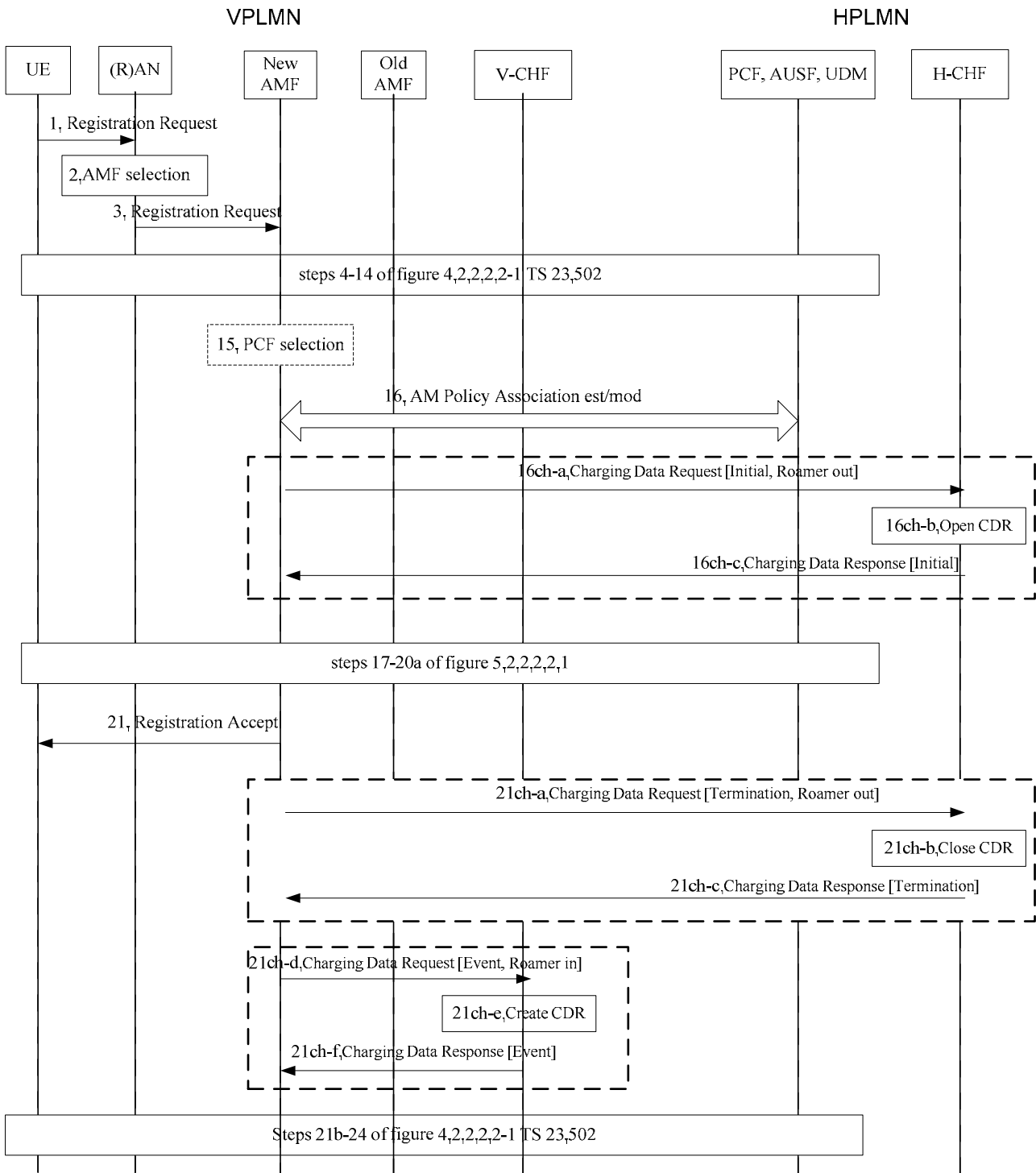

Figure 5.2.2.5.4.1: Roaming Registration – ECUR to HPLMN and AMF to H-CHF and V-CHF

1-16. Registration procedure initiated by UE per steps 1 to 16 of figure 4.2.2.2-1 of TS 23.502 [201], with PCF, AUSF and UDM in HPLMN.

16ch-a. Upon Registration checked trigger, the AMF sends Charging Data Request [Initial] to H-CHF for the UE registration to be granted authorization, indicating "roamer out".

16ch-b. Account and Rating control by the H-CHF for the registration and open a CDR.

16ch-c. The H-CHF acknowledges by sending Charging Data Response [Initial] to the AMF in VPLMN, granting authorization to the registration.

17 to 21. Same steps as in Figure 5.2.2.2.1.

21ch-a. The AMF in VPLMN sends Charging Data Request [Termination] to H-CHF for the UE successful registration.

21ch-b. The H-CHF closes the CDR for this registration.

21ch-c. The H-CHF acknowledges by sending Charging Data Response [Termination] to the AMF in VPLMN.

21ch-d. The AMF in VPLMN sends Charging Data Request [Event] to V-CHF for the UE successful registration, indicating "roamer in".

21ch-e. The V-CHF creates the CDR for this registration.

21ch-f. The V-CHF acknowledges by sending Charging Data Response [Event] to the AMF in VPLMN.

21b to 24. Same steps as in Figure 5.2.2.2.1.

5.2.2.5.5 Deregistration – PEC to HPLMN and AMF to H-CHF and V-CHF

The following figure 5.2.2.5.5.1 describes a deregistration UE-initiated or Network-initiated in PEC to HPLMN for roaming, based on figure 4.2.2.3.2-1 and figure 4.2.2.3.3-1 of TS 23.502 [201], where the AMF interacts with H-CHF and V-CHF.

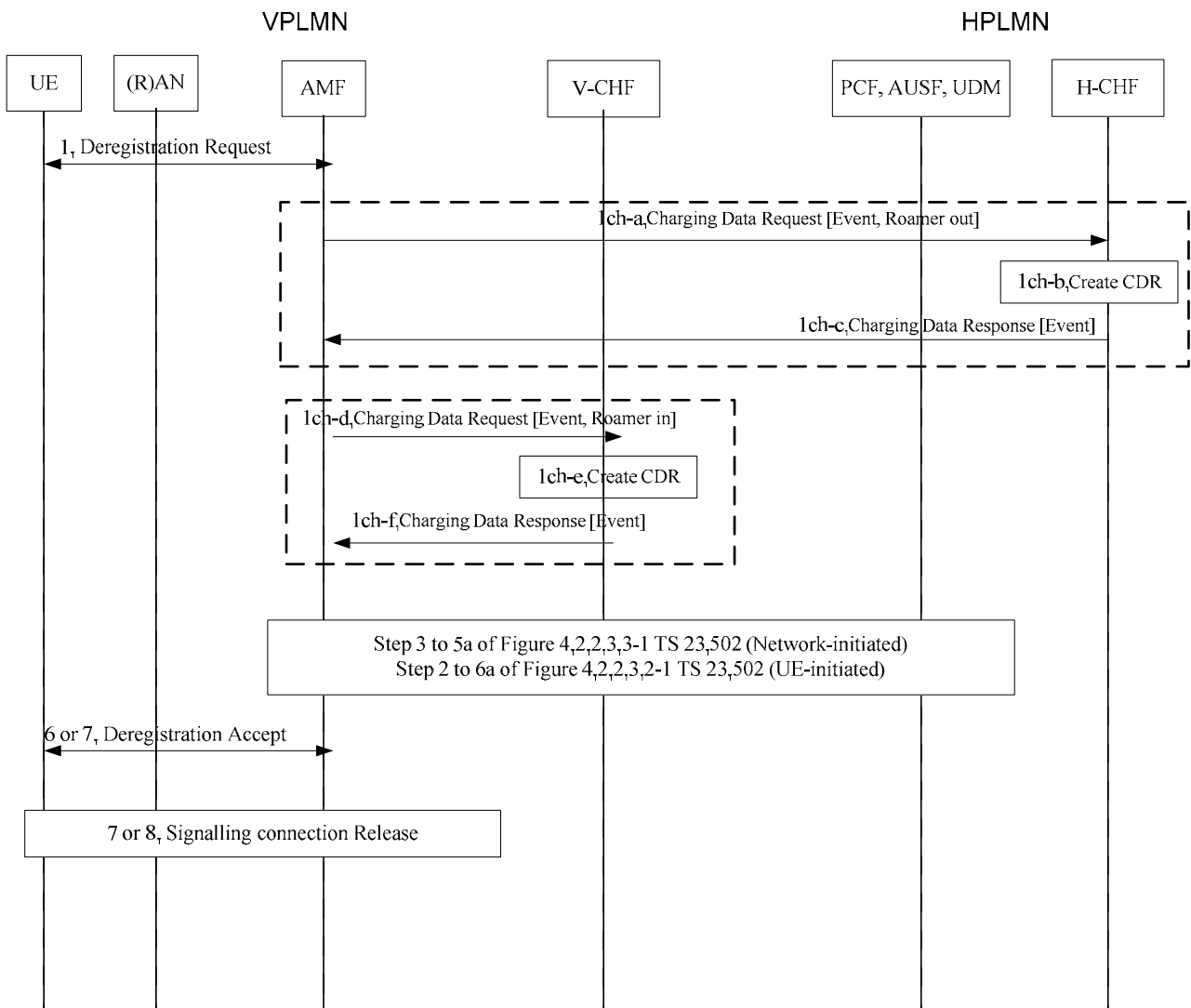

Figure 5.2.2.5.5.1: Roaming Deregistration – PEC to HPLMN and AMF to H-CHF and V-CHF

1. Deregistration Request from the UE or towards the UE.

1ch-a. Upon Deregistration trigger, the AMF in VPLMN sends Charging Data Request [Event] to H-CHF for the UE successful deregistration, indicating "roamer out".

1ch-b. The H-CHF creates the CDR for this deregistration.

1ch-c. The H-CHF acknowledges by sending Charging Data Response [Event] to the AMF in VPLMN.

1ch-d. The AMF in VPLMN sends Charging Data Request [Event] to V-CHF for the UE successful deregistration, indicating "roamer in".

1ch-e. The V-CHF creates the CDR for this deregistration.

1ch-f. The V-CHF acknowledges by sending Charging Data Response [Event] to the AMF in VPLMN

2-8 Deregistration procedure steps.

5.2.2.5.6 Registration - PEC to HPLMN and AMF to V-CHF

The following figure 5.2.2.5.6.1 describes a Registration charging message flow in PEC to HPLMN scenario for roaming, based on figure 4.2.2.2.2-1 of TS 23.502 [201], where the AMF interacts with V-CHF and V-CHF interacts with H-CHF.

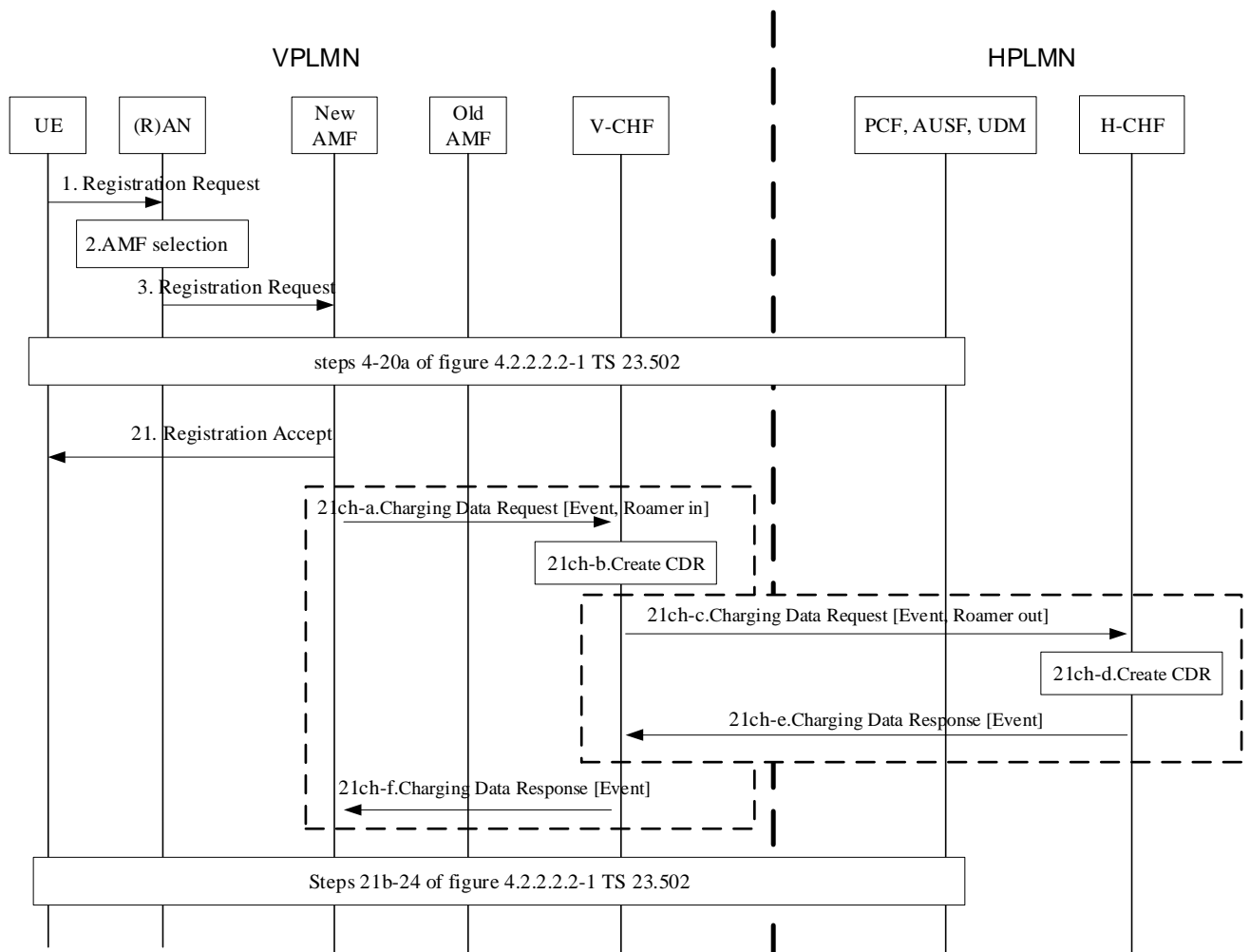

Figure 5.2.2.5.6.1: Roaming Registration – PEC to HPLMN and AMF to H-CHF

1-20a. Registration procedure initiated by UE per steps 1 to 20a of figure 4.2.2.2.2-1 of TS 23.502 [201], with PCF, AUSF and UDM in HPLMN.

21. Upon successful procedure, Registration Accept sent to the UE.

- 21ch-a. The AMF in VPLMN sends Charging Data Request [Event] to the V-CHF for the UE successful registration, indicating "roamer in".
- 21ch-b. The V-CHF creates the CDR for this registration.
- 21ch-c. Upon reception of Charging Data Request [Event] for a Registration completed trigger, indicating "roamer in", the V-CHF may send Charging Data Request [Event] to H-CHF for the UE successful registration, indicating "roamer out".
- 21ch-d. The H-CHF creates the CDR for this registration.
- 21ch-e. The H-CHF acknowledges by sending Charging Data Response [Event] to the V-CHF.
- 21ch-f. The V-CHF acknowledges by sending Charging Data Response [Event] to the AMF in VPLMN. Depending on operator policies this step may be performed before 21ch-c.
- 21b-24. Registration procedure continues as per steps 21b to 24 of figure 4.2.2.2.2-1 of TS 23.502 [201].

5.2.2.5.7 Registration – IEC to HPLMN and AMF to V-CHF

The following figure 5.2.2.5.7.1 describes a Registration charging message flows in IEC to HPLMN scenario for roaming, based on the clause 5.2.2.2.2, where the AMF interacts with V-CHF and V-CHF interacts with H-CHF.

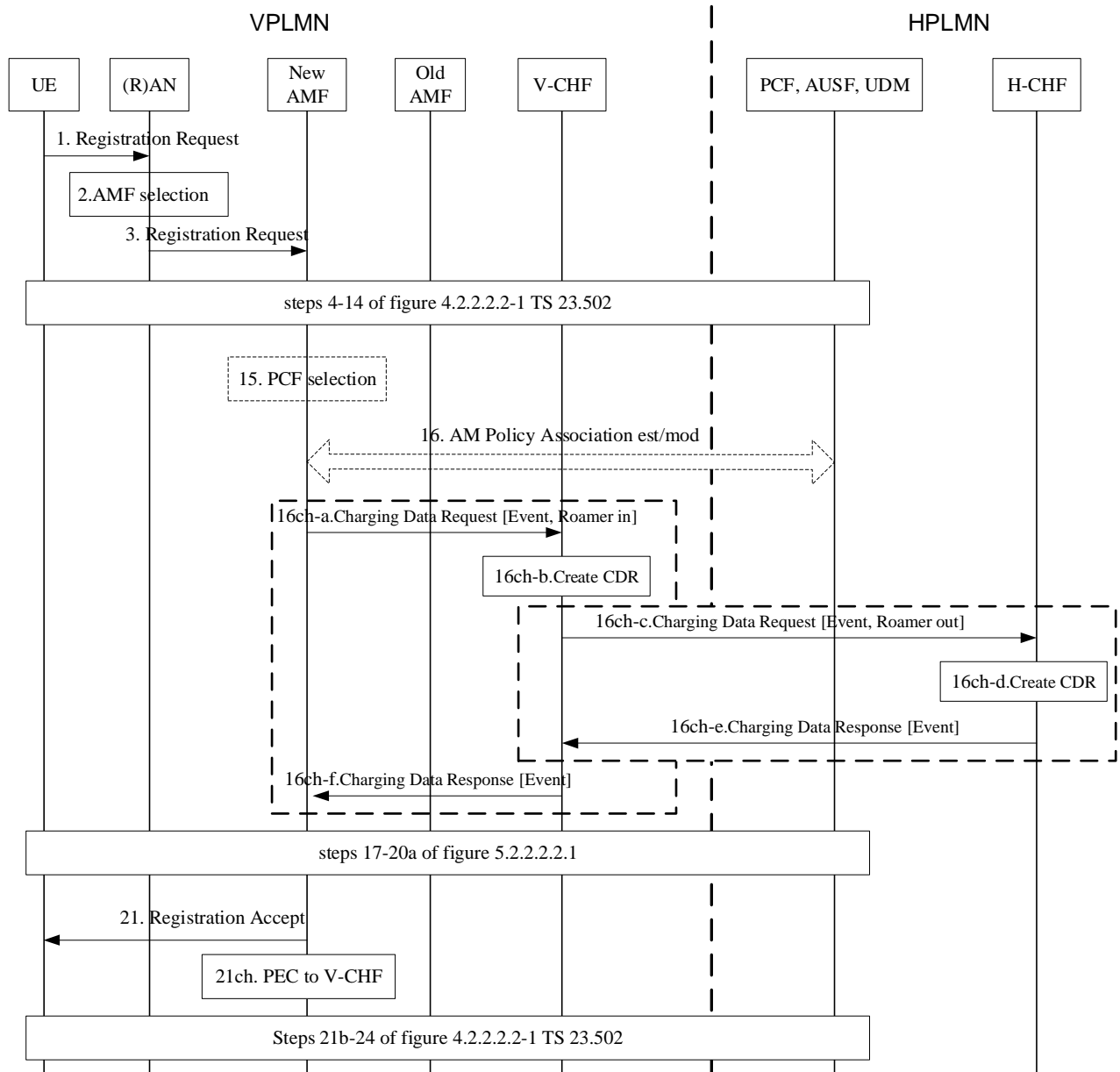

Figure 5.2.2.5.7.1: Roaming Registration – IEC to HPLMN and AMF to V-CHF

- 1-16. Registration procedure initiated by UE per steps 1 to 16 of figure 4.2.2.2.2-1 of TS 23.502 [201], with PCF, AUSF and UDM in HPLMN.
- 16ch-a. Upon Registration checked trigger, the AMF in VPLMN sends Charging Data Request [Event] to V-CHF for the UE registration to be granted authorization, rated and accounted, indicating "roamer in".
- 16ch-b. The V-CHF creates the CDR for this registration.
- 16ch-c. Upon reception of Charging Data Request [Event] for a Registration completed trigger, indicating "roamer in", the V-CHF may send Charging Data Request [Event] to H-CHF for the UE successful registration, indicating "roamer out".
- 16ch-d. Accounting and Rating control by the H-CHF for the registration and CDR creation.
- 16ch-e. The H-CHF acknowledges by sending Charging Data Response [Event] to the V-CHF, granting authorization to the registration.

16ch-f. The V-CHF forwards the acknowledges from the H-CHF by sending Charging Data Response [Event] to the AMF in VPLMN, granting authorization to the registration.

17 to 21. Same steps as in figure 5.2.2.2.2.1.

21ch. The AMF and V-CHF may perform a PEC following clause 5.2.2.5.2 steps 21ch-d to 21-ch-f.

21b to 24. Same steps as in figure 5.2.2.2.2.1.

5.2.2.5.8 Registration – ECUR to HPLMN and AMF to V-CHF

The following figure 5.2.2.5.8.1 describes a Registration charging message flows in ECUR to HPLMN scenario for roaming, based on the clause 5.2.2.2.2, where the AMF interacts with V-CHF and V-CHF interacts with H-CHF.

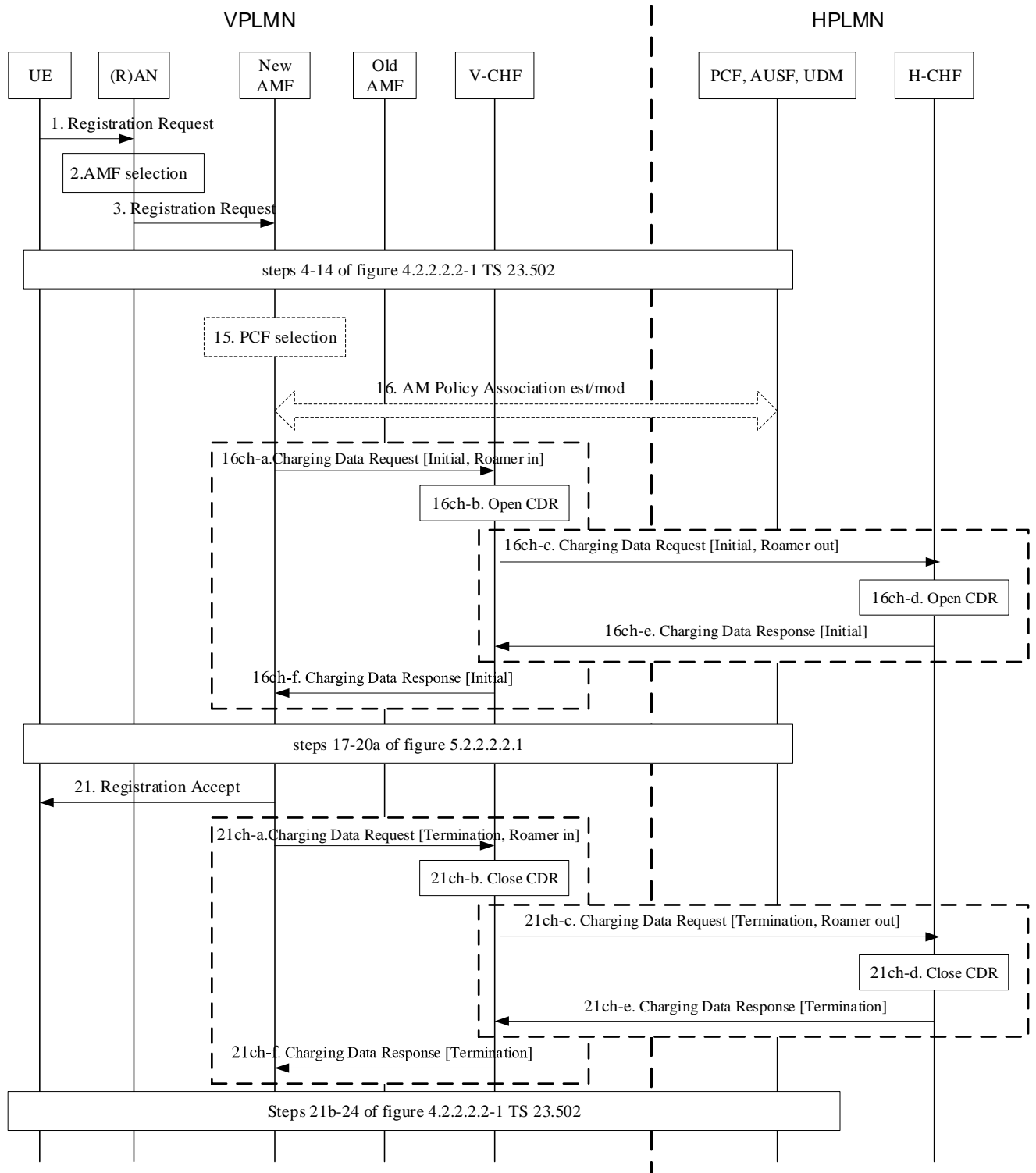

Figure 5.2.2.5.8.1: Roaming Registration – ECUR to HPLMN and AMF to V-CHF

1-16. Registration procedure initiated by UE per steps 1 to 16 of figure 4.2.2.2-1 of TS 23.502 [201], with PCF, AUSF and UDM in HPLMN.

16ch-a. Upon Registration checked trigger, the AMF in VPLMN sends Charging Data Request [Initial] to V-CHF for the UE registration to be granted authorization, rated, and accounted, indicating "roamer in".

16ch-b. The V-CHF opens the CDR for this registration.

- 16ch-c. Upon reception of Charging Data Request [Initial] for a Registration completed trigger, indicating "roamer in", the V-CHF may send Charging Data Request [Initial] to H-CHF for the UE successful registration, indicating "roamer out".
- 16ch-d. Accounting and Rating control by the H-CHF for the registration and opens the CDR.
- 16ch-e. The H-CHF acknowledges by sending Charging Data Response [Initial] to the V-CHF, granting authorization to the registration.
- 16ch-f. The V-CHF forwards the acknowledges from the H-CHF by sending Charging Data Response [Initial] to the AMF in VPLMN, granting authorization to the registration.
- 17 to 21. Same steps as in figure 5.2.2.2.1.
- 21ch-a. The AMF in VPLMN sends Charging Data Request [Termination] to H-CHF for the UE successful registration.
- 21ch-b. The V-CHF closes the CDR for this registration.
- 21ch-c. Upon reception of Charging Data Request [Termination] for the UE successful registration, the V-CHF may send Charging Data Request [Termination] to H-CHF for the UE successful registration.
- 21ch-d. The H-CHF closes the CDR for this registration.
- 21ch-e. The H-CHF acknowledges by sending Charging Data Response [Termination] to the V-CHF.
- 21ch-f. The V-CHF forwards the acknowledgement from the H-CHF by sending Charging Data Response [Termination] to the AMF in VPLMN.
- 21b to 24. Same steps as in figure 5.2.2.2.1.

5.2.2.5.9 Deregistration – PEC to HPLMN and AMF to V-CHF

The following figure 5.2.2.5.9.1 describes a deregistration UE-initiated or Network-initiated in PEC to HPLMN for roaming, based on figure 4.2.2.3.2-1 and figure 4.2.2.3.3-1 of TS 23.502 [201], where the AMF interacts with V-CHF and V-CHF interacts with H-CHF.]

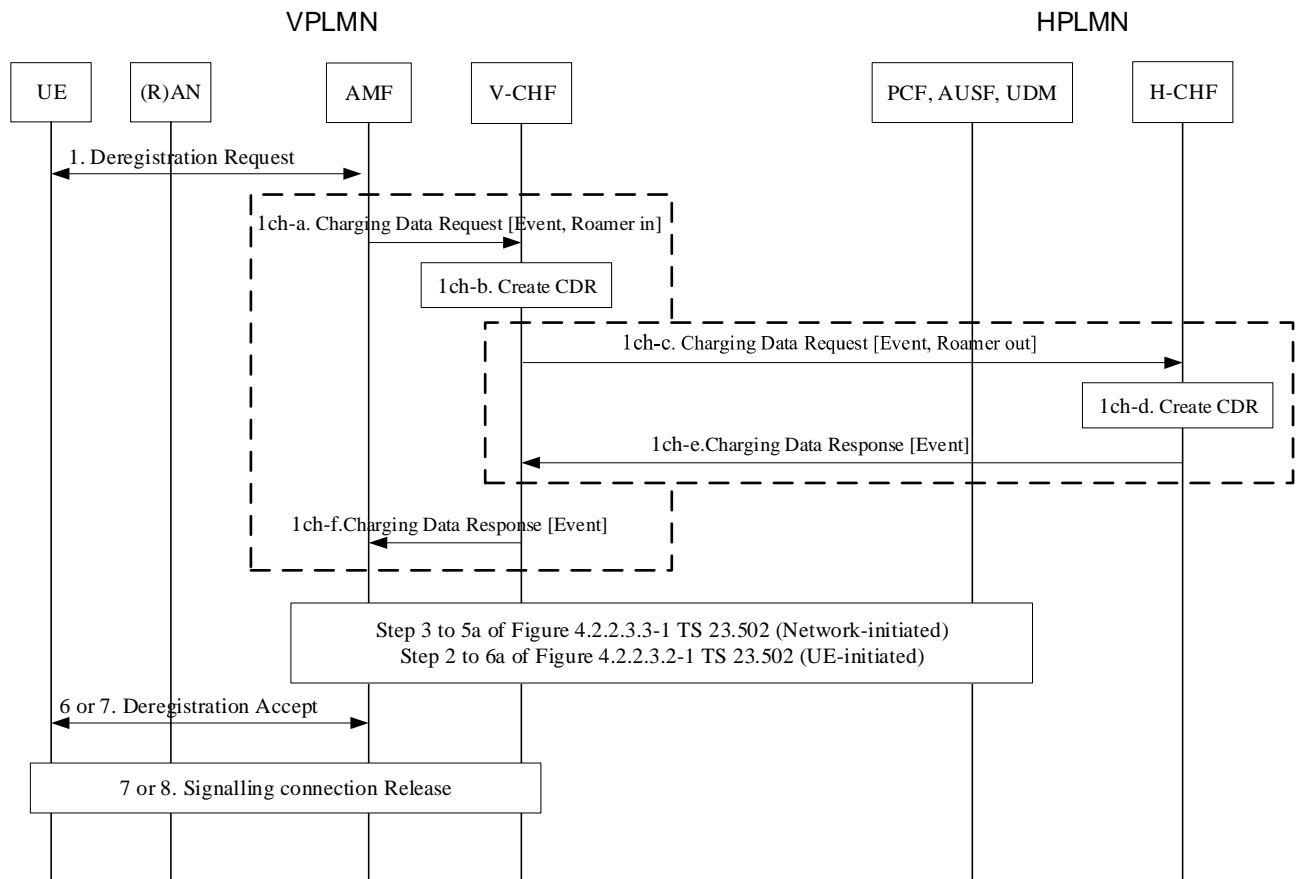

Figure 5.2.2.5.9.1: Roaming Deregistration – PEC to HPLMN and AMF to V-CHF

- 1. Deregistration Request from the UE or towards the UE.
- 1ch-a. Upon Deregistration trigger, the AMF in VPLMN sends Charging Data Request [Event] to V-CHF for the UE successful deregistration, indicating "roamer out".
- 1ch-b. The V-CHF creates the CDR for this deregistration.
- 1ch-c. Upon reception of Charging Data Request [Event] for the UE successful deregistration trigger, indicating "roamer in", the V-CHF may send Charging Data Request [Event] to H-CHF for the UE successful registration, indicating "roamer out".
- 1ch-d. The H-CHF creates the CDR for this deregistration.
- 1ch-e. The H-CHF acknowledges by sending Charging Data Response [Event] to the V-CHF.
- 1ch-f. The V-CHF acknowledges by sending Charging Data Response [Event] to the AMF in VPLMN. Depending on operator policies this step may be performed before 1ch-c.
- 2-8. Deregistration procedure steps, following figure 4.2.2.3.2-1 and figure 4.2.2.3.3-1 of TS 23.502 [201]

5.2.2.6 UE registration charging based on Business converged charging

5.2.2.6.1 General

The clause below describes UE registration converged charging influenced by business converged charging based the C-CHF and B-CHF architecture defined in clause 4.3.

The flows are applicable for Network slice converged charging based on UE registration where the B-CHF handles the Tenant the Network Slice is assigned to.

5.2.2.6.2 Registration - ECUR

The following figure 5.2.2.6.2-1 describes a UE registration converged charging influenced by business converged charging:

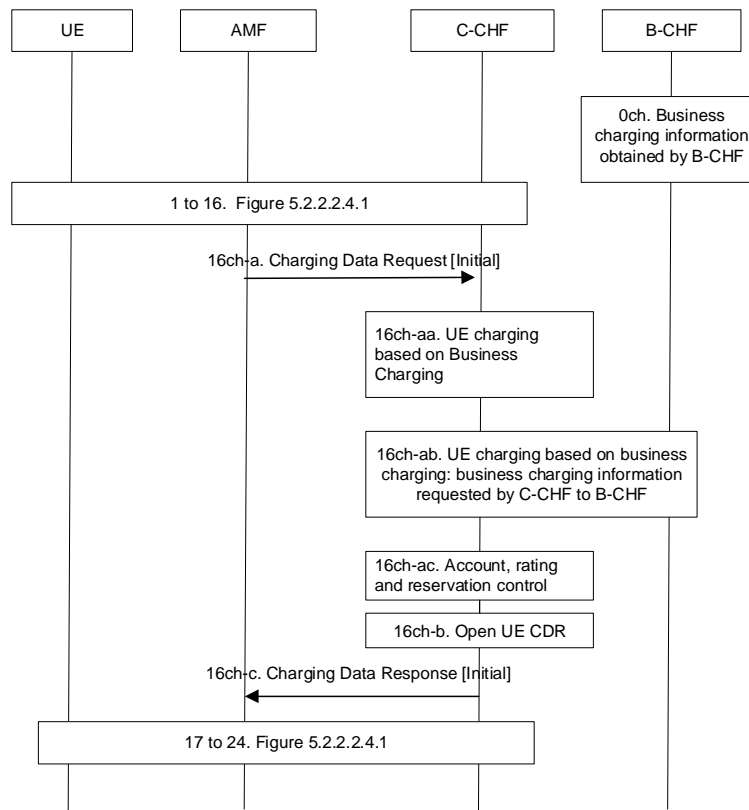

Figure 5.2.2.6.2-1: UE registration converged charging influenced by business charging

0ch. Business charging information obtained by B-CHF (e.g. from NWDAF, MnS Producer, NSACF, etc) which could be e.g:

- S-NSSAI service profile: e.g. "Max nb of PDU sessions", "Max nb of UEs", "Duration of the slice"...

1 to 16ch-a. UE registration for individual UE – ECUR per Figure 5.2.2.4.1.

16ch-aa. UE PDU session charging needs input from business charging

16ch-ab. C-CHF sends a request to B-CHF, and receives charging information from B-CHF.

When Business charging is Network slice charging, the step 16ch-ab occurs for each S-NSSAI of the "Allowed NSSAI" received in step 16ch-a.

The messages exchange between C-CHF and B-CHF for this scenario is not specified in this release of the specification.

16ch-ac. Account, Rating and reservation control for individual UE based on charging information received from B-CHF(s).

16ch-c. C-CHF provides appropriate Charging Data Response [Initial] for the individual UE.

17 to 24. UE registration charging for individual UE per Figure 5.2.2.4.1.

5.2.3 CDR generation

5.2.3.1 Introduction

The CHF CDRs for 5G connection and mobility charging are generated by the CHF to collect charging information that they subsequently transfer to the Charging Gateway Function (CGF).

The following clauses describe in detail the conditions for generating the CHF CDR, which shall be supported by the CHF.

5.2.3.2 Triggers for CHF CDR

5.2.3.2.1 General

A 5G connection and mobility charging CHF CDR is used to collect charging information related to 5G connection and mobility chargeable events for PEC, IEC and ECUR.

5.2.3.2.2 Triggers for CHF CDR generation

A CHF CDR shall be generated by the CHF for each received Charging Data Request [Event].

5.2.3.2.3 Triggers for CHF CDR opening

A CHF CDR shall be opened when the CHF receives Charging Data Request [Initial].

5.2.3.2.4 Triggers for CHF CDR closure

The CHF CDR shall be closed when the CHF receives Charging Data Request [Termination].

5.2.4 Ga record transfer flows

Details of the Ga protocol application are specified in TS 32.295 [54].

5.2.5 Bam CDR file transfer

Details of the Bam protocol application are specified in TS 32.297 [52].

6. Definition of charging information

6.1 Data description for 5G connection and mobility charging

6.1.1 Message contents

6.1.1.1 General

The Charging Data Request and Charging Data Response are specified in TS 32.290 [57] and include charging information. The Charging Data Request can be of type [Event].

Table 6.1.1.1.1 describes the use of these messages for converged charging.

Table 6.1.1.1.1: Converged charging messages reference table

Message	Source	Destination
Charging Data Request	AMF	CHF
Charging Data Response	CHF	AMF

The following clauses describe the different fields used in the Charging Data messages and the category in the tables is used according to the charging data configuration defined in clause 5.4 of TS 32.240 [1].

6.1.1.2 Charging Data Request message

Table 6.1.1.2.1 illustrates the basic structure of a Charging Data Request message from the AMF as used for 5G connection and mobility converged charging.

Table 6.1.1.2.1: Charging Data Request message contents

Information Element	Category for converged charging	Description
Session Identifier	O _C	Described in TS 32.290 [57]
Subscriber Identifier	O _M	Described in TS 32.290 [57] In case Subscriber Identifier (i.e. SUPI) is not present (for emergency service), the User Equipment Info in table 6.2.1.2.1 shall be present for identifying the user.
Tenant Identifier	O _C	Described in TS 32.290 [57]. This field may be used in the business context.
NF Consumer Identification	M	Described in TS 32.290 [57]
NF Functionality	M	Described in TS 32.290 [57]
NF Name	O _C	Described in TS 32.290 [57]
NF Address	O _C	Described in TS 32.290 [57]
NF PLMN ID	O _C	Described in TS 32.290 [57]
Invocation Timestamp	M	Described in TS 32.290 [57]
Invocation Sequence Number	M	Described in TS 32.290 [57]
One-time Event	O _C	Described in TS 32.290 [57]
One-time Event Type	O _C	Described in TS 32.290 [57]
Supported Features	O _C	Described in TS 32.290 [57]
Service Specification Information	O _C	Described in TS 32.290 [57]
Multiple Unit Usage	O _C	Described in TS 32.290 [57].
Rating Group	M	Described in TS 32.290 [57]
Requested Unit	O _C	Described in TS 32.290 [57]
AMF Identifier	O _C	This field holds the AMF identifier.
AMF Charging Profile	O _C	This field holds the applicable AMF Charging Profile
Registration Charging Information	O _M	This field holds the registration specific information described in clause 6.2.1.2
N2 connection Charging Information	O _M	This field holds the N2 connection specific information described in clause 6.2.1.3
Location Reporting Charging information	O _M	This field holds the Location Reporting specific information described in clause 6.2.1.4
Inter-CHF Information	O _C	This field holds inter-CHF specific information described in clause 6.2.1.5

6.1.1.3 Charging data response message

Table 6.1.1.3.1 illustrates the basic structure of a Charging Data Response message from the CHF as used for 5G connection and mobility converged charging.

Table 6.1.1.3.1: Charging Data Response message contents

Information Element	Category for converged charging	Description
Session Identifier	O _c	Described in TS 32.290 [57]
Invocation Timestamp	M	Described in TS 32.290 [57]
Invocation Result	O _c	Described in TS 32.290 [57]
Invocation Result Code	O _c	Described in TS 32.290 [57]
Failed parameter	O _c	Described in TS 32.290 [57]
Failure Handling	O _c	Described in TS 32.290 [57]
Invocation Sequence Number	M	Described in TS 32.290 [57]
Session Failover	O _c	This field is not applicable.
Supported Features	O _c	Described in TS 32.290 [57]
Multiple Unit Information	O _c	This field is applicable for ECUR.
Result Code	O _c	Described in TS 32.290 [57]
Rating Group	O _M	Described in TS 32.290 [57]
Validity Time	O _c	Described in TS 32.290 [57]
AMF Charging Profile	O _c	This field holds the AMF Charging Profile to be applied
Location Reporting Charging information	O _c	This field holds the Location Reporting specific information described in clause 6.2.1.4
Inter-CHF Information	O _c	This field holds Inter-CHF specific information described in clause 6.2.1.5

6.1.2 Ga message contents

See clause 5.2.4.

6.1.3 CDR description on the B_{am} interface

6.1.3.1 General

This clause describes the CDR content and format generated for 5G connection and mobility charging

The following tables provide a brief description of each CDR parameter. The category in the tables is used according to the charging data configuration defined in clause 5.4 of TS 32.240 [1]. Full definitions of the CDR parameters, sorted by the name in alphabetical order, are provided in TS 32.298 [51].

6.1.3.2 Registration charging CHF CDR data

If enabled, CHF CDRs for Registration charging shall be produced for each registration and deregistration

The fields of Registration charging CHF CDR are specified in table 6.1.3.2.1.

Table 6.1.3.2.1: Registration charging CHF record data

Field	Category	Description
Record Type	M	CHF record.
Recording Network Function ID	O _M	This field holds the name of the recording entity, i.e. the CHF id.
Subscriber Identifier	O _M	This field holds the 5G Subscription Permanent Identifier (SUPI) of the served party. This fields should be present except for emergency session.
Tenant Identifier	O _C	Described in TS 32.298 [51]. It may be used in the business context.
NF Consumer Information	M	This field holds the information of the AMF that used the charging service.
NF Functionality	M	This field contains the function of the node (i.e. AMF)
NF Name	O _C	This field holds the name of the AMF used.
NF Address	O _C	This field holds the IP Address of the AMF used.
NF PLMN ID	O _C	This field holds the PLMN identifier (MCC MNC) of the AMF.
Record Opening Time	M	Described in TS 32.298 [51]
Duration	M	Described in TS 32.298 [51]
Record Sequence Number	C	Described in TS 32.298 [51]
Cause for Record Closing	M	Described in TS 32.298 [51]
Diagnostics	O _M	Described in TS 32.298 [51]
Local Record Sequence Number	O _M	Described in TS 32.298 [51]
Record Extensions	O _C	Described in TS 32.298 [51]
AMF Identifier	O _C	This field holds the AMF identifier.
Registration Charging Information	O _M	This field holds the 5G registration specific information defined in clause 6.2.1.2.
Inter-CHF Information	O _C	This field holds inter-CHF specific information described in clause 6.2.1.5

6.1.3.3 N2 connection charging Information CHF CDR data

If enabled, CHF CDRs for N2 connection charging shall be produced for each N2 connection establishment and release.

The fields of N2 connection charging CHF CDR are specified in table 6.1.3.3.1.

Table 6.1.3.3.1: N2 connection charging CHF record data

Field	Category	Description
Record Type	M	CHF record.
Recording Network Function ID	O _M	This field holds the name of the recording entity, i.e. the CHF id.
Subscriber Identifier	O _M	This field holds the 5G Subscription Permanent Identifier (SUPI) of the served party. This fields should be present except for emergency session.
NF Consumer Information	M	This field holds the information of the AMF that used the charging service.
NF Functionality	M	This field contains the function of the node (i.e. AMF)
NF Name	O _C	This field holds the name of the AMF used.
NF Address	O _C	This field holds the IP Address of the AMF used.
NF PLMN ID	O _C	This field holds the PLMN identifier (MCC MNC) of the AMF.
Record Opening Time	O _C	Described in TS 32.298 [51]
Duration	M	Described in TS 32.298 [51]
Record Sequence Number	C	Described in TS 32.298 [51]
Cause for Record Closing	M	Described in TS 32.298 [51]
Local Record Sequence Number	O _M	Described in TS 32.298 [51]
Record Extensions	O _C	Described in TS 32.298 [51]
AMF Identifier	O _C	This field holds the AMF identifier.
N2 connection charging Information	O _M	This field holds the N2 connection specific information defined in clause 6.2.1.3
Inter-CHF Information	O _C	This field holds inter-CHF specific information described in clause 6.2.1.5

6.1.3.4 Location reporting charging CHF CDR data

If enabled, CHF CDRs for Location reporting charging shall be produced for each Location reporting.

The fields of Location reporting charging CHF CDR are specified in table 6.1.3.4.1.

Table 6.1.3.4.1: Location reporting charging CHF record data

Field	Category	Description
Record Type	M	CHF record.
Recording Network Function ID	O _M	This field holds the name of the recording entity, i.e. the CHF id.
Subscriber Identifier	O _M	This field holds the 5G Subscription Permanent Identifier (SUPI) of the served party. This fields should be present except for emergency session.
NF Consumer Information	M	This field holds the information of the AMF that used the charging service.
NF Functionality	M	This field contains the function of the node (i.e. AMF)
NF Name	O _C	This field holds the name of the AMF used.
NF Address	O _C	This field holds the IP Address of the AMF used.
NF PLMN ID	O _C	This field holds the PLMN identifier (MCC MNC) of the AMF.
Record Opening Time	M	Described in TS 32.298 [51]
Duration	M	Described in TS 32.298 [51]
Record Sequence Number	C	Described in TS 32.298 [51]
Cause for Record Closing	M	Described in TS 32.298 [51]
Local Record Sequence Number	O _M	Described in TS 32.298 [51]
Record Extensions	O _C	Described in TS 32.298 [51]
AMF Identifier	O _C	This field holds the AMF identifier.
Location reporting charging Information	O _M	This field holds the Location reporting specific information defined in clause 6.2.1.4.
Inter-CHF Information	O _C	This field holds inter-CHF specific information described in clause 6.2.1.5

6.2 5G connection and mobility charging specific parameters

6.2.1 Definition of 5G connection and mobility charging information

6.2.1.1 General

The Charging Information parameter used for 5G connection and mobility charging is provided in the following clauses.

6.2.1.2 Definition of registration charging information

Specific charging information used for 5G registration charging is provided within the Registration Charging Information.

The detailed structure of the Registration Charging Information can be found in table 6.2.1.2.1.

Table 6.2.1.2.1: Structure of Registration Charging Information

Information Element	Category	Description
Registration message type	M	This field holds the message type received by the AMF associated to registration: registration (initial, mobility, periodic, emergency), deregistration.
User Information	O _M	Group of user information.
User Identifier	O _C	This field contains the identification of the user (i.e. GPSI).
User Equipment Info	O _C	This field holds the identification of the terminal (i.e. PEI, MAC Address) It may be used for identifying the user and shall be present in case Subscriber Identifier is not present.
unauthenticatedFlag	O _C	This field indicates the served SUPI is not authenticated.
Roamer In Out	O _C	This field holds an indication if the roamer is in-bound or out-bound. This field is present only if UE is identified as a roamer.
Disaster Roaming Indicator	O _C	This field may be set when the UE is registered for Disaster Roaming service specified in clause 5.40 of TS 23.501 [200].
UE 5GMM Core Network Capability	O _C	This field holds the UE 5GMM Core Network Capability included in UE MM Core network capabilities, as specified in clause 5.4.4a TS 23.501 [200]
MICO Mode Indication	O _C	This field indicates whether the MICO Mode is applicable or not.
SMS Supported Indication	O _C	This field indicates whether SMS is supported or not.
RAT Type	O _C	This field holds the Radio Access Technology (RAT) currently serving the UE.
TAI List	O _C	This field holds a set of tracking areas composing the Registration Area.
User Location Info	O _C	This field indicates details of where the UE is currently located (access-specific user location information).
PSCell Information	O _C	This field holds the PSCell: Primary SCG (Secondary Cell Group) Cell
UE Time Zone	O _C	This field holds the Time Zone of where the UE is located, if available where the UE currently resides.
Mobility Restrictions	O _C	This field holds the Mobility Restrictions applicable to the UE: RAT restriction, Forbidden area, Service area restrictions and Core Network type restriction.
Requested NSSAI	O _C	This field holds the requested NSSAI.
Allowed NSSAI	O _C	This field holds the allowed NSSAI consisting of one or more S-NSSAIs for serving PLMN in the present Registration Area.
Rejected NSSAI	O _C	This field holds the rejected NSSAI.
NSSAI mapping list	O _C	This field holds the mapping of VPLMN S-NSSAIs to HPLMN S-NSSAIs. This field is applicable only in VPLMN for roaming scenarios.
Alternative NSSAI Map	O _C	This field holds the list of mapping between the S-NSSAI to be replaced and the alternative S-NSSAI
AMF UE NGAP ID	O _M	This fields holds the UE association over the N2 interface within the AMF.
RAN UE NGAP ID	O _M	This fields holds the RAN UE NGAP ID over N2 interface.
RAN Node Id	O _M	This fields holds the Global RAN Node ID.
SNPN ID	O _C	This field holds PLMN ID and the NID which identifies the SNPN. The PLMN ID is the same as PLMN ID of the SUPI.
CAG ID List	O _C	This field holds the Closed Access Group Identifier List.
Satellite Access Indicator	O _C	This field holds the use of Satellite Access.
Service-level-AA	O _C	This field holds the upper layer information for authentication and authorization. It indicates that the UE supporting UAS services requests a registration for UAS services referring to clause 8.2.6.35 of TS 24.501 [206].

6.2.1.3 Definition of N2 Connection charging information

Specific charging information used for 5G N2 Connection charging is provided within the N2 connection charging Information.

The detailed structure of the N2 connection Charging Information can be found in table 6.2.1.3.1.

Table 6.2.1.3.1: Structure of N2 Connection Charging Information

Information Element	Category	Description
N2 Connection message type	M	This field holds the N2 message type received by the AMF.
User Information	O _M	Group of user information.
User Identifier	O _C	This field contains the identification of the user (i.e. GPSI).
User Equipment Info	O _C	This field holds the identification of the terminal (i.e. PEI, MAC Address) It is used for identifying the user in case SUPI is not present during emergency service.
unauthenticatedFlag	O _C	This field indicates the served SUPI is not authenticated.
User Location Info	O _C	This field indicates details of where the UE is currently located (access-specific user location information).
PSCell Information	O _C	This field holds the PSCell: Primary SCG (Secondary Cell Group) Cell
UE Time Zone	O _C	This field holds the Time Zone of where the UE is located, if available where the UE currently resides.
RAT Type	O _C	This field holds the Radio Access Technology (RAT).
AMF UE NGAP ID	O _M	This fields holds the UE association over the N2 interface within the AMF.
RAN UE NGAP ID	O _M	This fields holds the RAN UE NGAP ID over N2 interface.
RAN Node Id	O _M	This fields holds the Global RAN Node ID.
Mobility Restrictions	O _C	This field holds the Mobility Restrictions applicable to the UE: RAT restriction, Forbidden area, Service area restrictions and Core Network type restriction.
Allowed NSSAI	O _C	This field holds the allowed NSSAI consisting of one or more S-NSSAIs for serving PLMN in the present Registration Area.
NSSAI mapping list	O _C	This field holds the mapping of VPLMN S-NSSAIs to HPLMN S-NSSAIs. This field is applicable only in VPLMN for roaming scenarios.
RRC Establishment Cause	O _C	This fields holds the reason for RRC Connection Establishment as received from the UE.
Satellite Access Indicator	O _C	This field holds the use of Satellite Access.

6.2.1.4 Definition of Location Reporting charging information

Specific charging information used for 5G Location Reporting charging is provided within the Location reporting charging Information.

The detailed structure of the Location reporting charging Information can be found in table 6.2.1.4.1.

Table 6.2.1.4.1: Structure of Location Reporting Charging Information

Information Element	Category	Description
Location reporting message type	M	This field holds the location reporting message type received by the AMF.
User Information	O _M	Group of user information.
User Identifier	O _C	This field contains the identification of the user (i.e. GPSI).
User Equipment Info	O _C	This field holds the identification of the terminal (i.e. PEI, MAC Address) It is used for identifying the user in case SUPI is not present during emergency service.
unauthenticatedFlag	O _C	This field indicates the served SUPI is not authenticated.
User Location Info	O _M	This field indicates details of where the UE is currently located under the access type.
PSCell Information	O _C	This field holds the PSCell: Primary SCG (Secondary Cell Group) Cell
UE Time Zone	O _C	This field holds the Time Zone of where the UE is located, if available where the UE currently resides.
Presence Reporting Area Information	O _C	This field contains the Presence Reporting Area Information of UE as defined in TS 23.501 [200], comprising the Presence Reporting Area identifier(s) and an indication on whether the UE is inside or outside the Presence Reporting Area, if available.
RAT Type	O _C	This field holds the Radio Access Technology (RAT).
Satellite Access Indicator	O _C	This field holds the use of Satellite Access.

6.2.1.5 Definition of inter-CHF information

Specific charging information used for information when the V-CHF have a connection to the H-CHF.

The detailed structure of the inter-CHF Information can be found in table 6.2.1.5.1.

Table 6.2.1.5.1: Structure of Inter-CHF Information

Information Element	Category	Description
Remote CHF resource	O _C	This field holds the reference to the Charging Data resource in the CHF not directly connected to the NF (i.e., H-CHF) (NOTE 1)
Original NF Consumer Id	O _C	This field holds information on the NF triggering the request i.e., AMF (NOTE 2)
NOTE 1: The Remote CHF resource is included in the response to the original NF if inter-CHF communication has been used.		
NOTE 2: The Original NF Consumer Id is included in the request from the original NF if inter-CHF is expected to be used.		

6.2.2 Formal 5G connection and mobility charging parameter description

6.2.2.1 5G connection and mobility CHF CDR parameters

The detailed definitions, abstract syntax and encoding of 5G connection and mobility CHF CDRs parameters are specified in TS 32.298 [51].

6.2.2.2 5G connection and mobility resources attributes

The detailed definitions of resources attributes used for 5G connection and mobility charging are specified in TS 32.291 [58].

6.2.3 Detailed message format for converged charging

The following clause specifies per Operation Type the charging data that are sent by AMF for 5G connection and mobility converged charging.

The Operation Types are listed in the following order: I (Initial)/T (Termination)/E (Event). Therefore, when all Operation Types are possible it is marked as ITE. If only some Operation Types are allowed for a node, only the appropriate letters are used (i.e. IT or E) as indicated in the table heading. The omission of an Operation Type for a particular field is marked with “-“ (i.e. I-E). Also, when an entire field is not allowed in a node the entire cell is marked as “-“.

Table 6.2.3.1 defines the basic structure of the supported fields in the *Charging Data Request* message for AMF converged charging.

Table 6.2.3.1: Supported fields in Charging Data Request message

Information Element	Functionality of AMF	Reg.	N2 cnt	Loc. Report.
	Supported Operation Types	I/T/E	E	E
Session Identifier		ITE	E	E
Subscriber Identifier		ITE	E	E
Tenant Identifier		ITE	-	-
NF Consumer Identification		ITE	E	E
NF Functionality		ITE	E	E
NF Name		ITE	E	E
NF Address		ITE	E	E
NF PLMN ID		ITE	E	E
Invocation Timestamp		ITE	E	E
Invocation Sequence Number		ITE	E	E
One-time Event		--E	E	E
One-time Event Type		--E	E	E
Supported Features		I-E	E	E
Service Specification Information		ITE	E	E
Multiple Unit Usage		ITE	-	-
Rating Group		IT-	-	-
Requested Unit		IT-	-	-
AMF Identifier		ITE	E	E
AMF Charging Profile		IT-E	E	E
Registration Charging Information				
Registration Message type		ITE	-	-
User Information		ITE	-	-
UE 5GMM Core Network Capability		ITE	-	-
MICO Mode Indication		ITE	-	-
SMS Supported Indication		ITE	-	-
Access Type		ITE	-	-
RAT Type		ITE	-	-
TAI List		ITE	-	-
User Location Info		ITE	-	-
PSCell Information		ITE	-	-
UE Time Zone		ITE	-	-
Mobility Restrictions		ITE	-	-
Requested NSSAI		ITE	-	-
Allowed NSSAI		ITE	-	-
Rejected NSSAI		ITE	-	-
NSSAI mapping list		ITE	-	-
Alternative NSSAI Map		ITE	-	-
AMF UE NGAP ID		ITE	-	-
RAN UE NGAP ID		ITE	-	-
RAN Node Id		ITE	-	-
SNPN ID		ITE	-	-
CAG ID List		ITE	-	-
Satellite Access Indicator		ITE	-	-
Service-level-AA		ITE	-	-
N2 Connection Charging Information				
N2 Connection Message type		-	E	-
User Information		-	E	-
User Location Info		-	E	-
PSCell Information		-	E	-
UE Time Zone		-	E	-
RAT Type		-	E	-
AMF UE NGAP ID		-	E	-
RAN UE NGAP ID		-	E	-
RAN Node Id		-	E	-
Mobility Restrictions		-	E	-
Allowed NSSAI		-	E	-
NSSAI mapping list		-	E	-
RRC Establishment Cause		-	E	-
Satellite Access Indicator		-	E	-
Location Reporting Charging information				
Location reporting Message type		-	-	E

Information Element	Functionality of AMF	Reg.	N2 cnt	Loc. Report.
	Supported Operation Types	I/T/E	E	E
User Information		-	-	E
User Location Info		-	-	E
PSCell Information		-	-	E
UE Time Zone		-	-	E
Presence Reporting Area Information		-	-	E
RAT Type		-	-	E
Satellite Access Indicator		-	-	E
Inter-CHF Information				
Remote CHF resource		-T-	-	-
Original NF Consumer Id		ITE	E	E

Table 6.2.3.2 defines the basic structure of the supported fields in the *Charging Data Response* message for AMF converged charging.

Table 6.2.3.2: Supported fields in Charging Data Response message

Information Element	Functionality of AMF	Reg.	N2 cnt	Loc. Report.
	Supported Operation Types	ITE	E	E
Session Identifier		ITE	E	E
Invocation Timestamp		ITE	E	E
Invocation Result		ITE	E	E
Invocation Sequence Number		ITE	E	E
Session Failover		I--	-	-
Supported Features		I-E	E	E
Multiple Unit information		IT-	-	-
Result Code		IT-	-	-
Rating Group		IT-	-	-
AMF Charging Profile		ITE	E	E
Location Reporting Charging information				
Presence Reporting Area Information		-	-	E
Inter-CHF Information				
Remote CHF resource		IT-	-	-

6.3 Bindings for 5G connection and mobility converged charging

This mapping between the Information Elements, resource attributes and CHF CDR parameters for 5G connection and mobility converged charging is described in clause 7 of TS 32.291 [58].

Annex A (normative): Charging Characteristics

A.1 General

A subscriber may have Charging Characteristics assigned to his subscription. Default Charging Characteristics may also be pre-provisioned on the AMF.

During UE Registration, the subscribed Charging Characteristics, if any, shall override the AMF pre-provisioned Charging Characteristics. The subscribed Charging Characteristics may be transferred from old AMF during UE context transfer or retrieved from UDM.

The Charging Characteristics parameter consists of a string of 16 bits designated as behaviours , freely defined by Operators. These behaviours may be things like:

- CHF addresses: to be used by the AMF, optionally with associated CHF instance ID(s), CHF set ID(s), CHF Group ID
- CHF selection method: this indicates how the AMF is to select the CHF instance e.g., local configuration, NRF (see clauses 5.1.3 and 5.1.5.2)
- Charging scenario: indicates the charging scenario to be used i.e., ECUR, IEC, or PEC
- Level: the default trigger levels for the Location reporting charging e.g., TAI, or Cell

One usage may be as a behaviour index associated to Registration, N2 connections and Location reporting in converged charging as described in the example in Table A.1.1:

Table A.1.1: Example of Charging Characteristics behaviours for AMF

Behaviour Index	CHF address	CHF selection method	Registration charging	N2 connections charging	Location reporting charging	
			Charging scenario	Charging scenario	Charging scenario	Level
0	CHF Set ID 1	NRF	ECUR	-	-	
1	Primary & secondary CHF addr. 1 & 2	Local config.	IEC	PEC	PEC	TAI, Cell
2	CHF Group ID 1	NRF	PEC	-	PEC	Cell
3	Primary & secondary CHF addr. 3 & 4	Local config.	-	PEC	PEC	TAI
...

Annex B (informative): Change history

Change history							
Date	Meeting	TDoc	CR	Rev	Cat	Subject/Comment	New version
2019-12	SA#86	SP-191183				Presented for approval	2.0.0
2019-12	SA#86					Change control version	16.0.0
2020-07	SA#88-e	SP-200509	0001	1	F	Add the Retransmission Indicator	16.1.0
2020-07	SA#88-e	SP-200509	0002	1	F	Correct the Event offline charging scenarios	16.1.0
2021-03	SA#91e	SP-210163	0003	-	F	Correction on Registration flows and message content	16.2.0
2021-03	SA#91e	SP-210163	0004	-	F	Correction on UE MM Core Network Capability	16.2.0
2022-03	-	-	-	-	-	Update to Rel-17 version (MCC)	17.0.0
2022-06	SA#96	SP-220521	0003	1	B	Add charging requirement for AMF to support NR RedCap	17.1.0
2022-12	SA#98e	SP-221171	0009	-	A	Correction on the Triggers for AMF	17.2.0
2022-12	SA#100	SP-230665	0010	1	B	Add Identifier of SNPN for 5G connection and mobility charging	18.0.0
2022-12	SA#100	SP-230664	0011	1	B	Slice-aware charging for Roaming partners	18.0.0
2023-09	SA#101	SP-230945	0013	-	A	Correction on AMF identifier	18.1.0
2023-09	SA#101	SP-230957	0014	1	B	Add identifier for PNI-NPN charging	18.1.1
2023-12	SA#102	SP-231470	0015	1	B	Rel-18 CR 32.256 Addition of end user charging for PNI-NPN network usage of access	18.2.0
2023-12	SA#102	SP-231470	0016	1	B	Rel-18 CR 32.256 Addition of end user charging for SNPN network usage of access	18.2.0
2023-12	SA#102	SP-231491	0020	1	A	Correction on triggers for AMF charging	18.2.0
2023-12	SA#102	SP-231454	0021	1	B	Add charging support for 5G connection via satellite access	18.2.0
2023-12	SA#102	SP-231461	0022	1	B	Rel-18 CR 32.256 Addition of CHF as consumer in LBO architecture	18.2.0
2023-12	SA#102	SP-231461	0023	1	B	Rel-18 CR 32.256 Addition of CHF selection by H-CHF	18.2.0
2023-12	SA#102	SP-231461	0024	1	B	Rel-18 CR 32.256 Addition of CHF to CHF flow	18.2.0
2023-12	SA#102	SP-231461	0025	1	B	Rel-18 CR 32.256 Addition of CHF information	18.2.0
2023-12	SA#102	SP-231495	0026	1	F	Rel-18 CR 32.256 Update on Triggers for AMF charging	18.2.0
2023-12	SA#102	SP-231461	0027	1	B	Rel-18 CR 32.256 Clarify the selection of two LBO roaming architectures	18.2.0
2024-03	SA#103	SP-240159	0028	1	B	Introduction of Alternative NSSAI	18.3.0
2024-03	SA#103	SP-240147	0029	1	B	Add the charging information for the satellite access charging	18.3.0
2024-03	SA#103	SP-240147	0030	1	B	Extend the user location for the satellite access charging	18.3.0
2024-03	SA#103	SP-240157	0031	1	B	Rel-18 CR 32.256 Addition of CHF information	18.3.0
2024-03	SA#103	SP-240157	0032	-	B	Rel-18 CR 32.256 Addition of inter-CHF CDR information	18.3.0
2024-06	SA#104	SP-240811	0033	1	F	Rel-18 CR 32.256 Correct charging information for 5G connection charging	18.4.0
2024-06	SA#104	SP-240829	0034	1	F	Rel-18 CR 32.256 Correction roaming architecture decision	18.4.0
2024-06	SA#104	SP-240811	0035	1	F	Rel-18 CR TS 32.256 non-roaming converged charging architecture in ref point	18.4.0
2024-06	SA#104	SP-240826	0036	1	F	Rel-18 CR TS 32.256 Introduce UE registration converged Charging influenced by NS charging architecture	18.4.0
2024-06	SA#104	SP-240826	0037	1	F	Rel-18 CR TS 32.256 Introduce scenario UE registration converged Charging influenced by NS charging	18.4.0
2024-07	SA#104					Correct indentation in Tables 6.1.1.3.1, 6.2.3.1, 6.2.3.2. Add missing addition (CR0033r1) in table 6.1.3.2.1.	18.4.1
2024-09	SA#105	SP-241174	0040	1	F	Rel-18 CR 32.256 Correction on roaming architecture	18.5.0
2024-09	SA#105	SP-241192	0042	1	F	Rel-18 CR 32.256 Correction Inter-CHF Information handling	18.5.0
2024-09	SA#105	SP-241189	0039	1	B	Rel-19 CR 32.256 Addition of NRF discovery reference	19.0.0
2024-12	SA#106	SP-241652	0044	1	A	Rel-19 CR 32.256 Correction on N107 and N108 for MVNO Charging	19.1.0
2024-12	SA#106	SP-241652	0046	1	A	Rel-18 CR 32.256 CHF Selection for Inter-CHF	19.1.0
2024-12	SA#106	SP-241661	0047	1	B	Rel-19 CR 32.256 Adding use of charging characteristics for CHF Group	19.1.0
2025-06	SA#108	SP-250540	0048	1	F	Rel-19 CR 32.256 Addition of architecture for network sharing	19.2.0
2025-06	SA#108	SP-250526	0049	1	B	Rel-19 CR 32.256 Clarify the CHF selection method	19.2.0
2025-06	SA#108	SP-250561	0050	1	B	Add UAS charging requirements	19.2.0
2025-06	SA#108	SP-250518	0052	1	B	Rel-19 CR 32.256 Add MVNO charging which provides satellite access service	19.2.0
2025-09	SA#109	SP-251077	0053		D	Rel-19 CR TS 32.256 Correction on references to internal clauses	19.3.0
2025-09	SA#109	SP-251092	0055	1	B	Rel-19 CR 32.256 Addition of disaster roaming indication charging	19.3.0
2025-09	SA#109	SP-251095	0056	1	B	Add Service-level-AA for support of UAS charging	19.3.0
2025-12	SA#110	SP-251397	0059	1	F	Rel-19 CR 32.256 Correction of Charging Characteristics use in AMF	19.4.0

History

Version	Date	Status
V19.3.0	October 2025	Publication
V19.4.0	February 2026	Publication