

ETSI TS 132 270 V18.2.0 (2024-05)



**Digital cellular telecommunications system (Phase 2+) (GSM);
Universal Mobile Telecommunications System (UMTS);
LTE;
5G;
Telecommunication management;
Charging management;
Multimedia Messaging Service (MMS) charging
(3GPP TS 32.270 version 18.2.0 Release 18)**



Reference

RTS/TSGS-0532270vi20

Keywords

5G,GSM,LTE,UMTS

ETSI

650 Route des Lucioles
F-06921 Sophia Antipolis Cedex - FRANCE

Tel.: +33 4 92 94 42 00 Fax: +33 4 93 65 47 16

Siret N° 348 623 562 00017 - APE 7112B
Association à but non lucratif enregistrée à la
Sous-Préfecture de Grasse (06) N° w061004871

Important notice

The present document can be downloaded from:

<https://www.etsi.org/standards-search>

The present document may be made available in electronic versions and/or in print. The content of any electronic and/or print versions of the present document shall not be modified without the prior written authorization of ETSI. In case of any existing or perceived difference in contents between such versions and/or in print, the prevailing version of an ETSI deliverable is the one made publicly available in PDF format at www.etsi.org/deliver.

Users of the present document should be aware that the document may be subject to revision or change of status.

Information on the current status of this and other ETSI documents is available at

<https://portal.etsi.org/TB/ETSIDeliverableStatus.aspx>

If you find errors in the present document, please send your comment to one of the following services:

<https://portal.etsi.org/People/CommitteeSupportStaff.aspx>

If you find a security vulnerability in the present document, please report it through our
Coordinated Vulnerability Disclosure Program:

<https://www.etsi.org/standards/coordinated-vulnerability-disclosure>

Notice of disclaimer & limitation of liability

The information provided in the present deliverable is directed solely to professionals who have the appropriate degree of experience to understand and interpret its content in accordance with generally accepted engineering or other professional standard and applicable regulations.

No recommendation as to products and services or vendors is made or should be implied.

No representation or warranty is made that this deliverable is technically accurate or sufficient or conforms to any law and/or governmental rule and/or regulation and further, no representation or warranty is made of merchantability or fitness for any particular purpose or against infringement of intellectual property rights.

In no event shall ETSI be held liable for loss of profits or any other incidental or consequential damages.

Any software contained in this deliverable is provided "AS IS" with no warranties, express or implied, including but not limited to, the warranties of merchantability, fitness for a particular purpose and non-infringement of intellectual property rights and ETSI shall not be held liable in any event for any damages whatsoever (including, without limitation, damages for loss of profits, business interruption, loss of information, or any other pecuniary loss) arising out of or related to the use of or inability to use the software.

Copyright Notification

No part may be reproduced or utilized in any form or by any means, electronic or mechanical, including photocopying and microfilm except as authorized by written permission of ETSI.

The content of the PDF version shall not be modified without the written authorization of ETSI.

The copyright and the foregoing restriction extend to reproduction in all media.

© ETSI 2024.

All rights reserved.

Intellectual Property Rights

Essential patents

IPRs essential or potentially essential to normative deliverables may have been declared to ETSI. The declarations pertaining to these essential IPRs, if any, are publicly available for **ETSI members and non-members**, and can be found in ETSI SR 000 314: "*Intellectual Property Rights (IPRs); Essential, or potentially Essential, IPRs notified to ETSI in respect of ETSI standards*", which is available from the ETSI Secretariat. Latest updates are available on the ETSI Web server (<https://ipr.etsi.org/>).

Pursuant to the ETSI Directives including the ETSI IPR Policy, no investigation regarding the essentiality of IPRs, including IPR searches, has been carried out by ETSI. No guarantee can be given as to the existence of other IPRs not referenced in ETSI SR 000 314 (or the updates on the ETSI Web server) which are, or may be, or may become, essential to the present document.

Trademarks

The present document may include trademarks and/or tradenames which are asserted and/or registered by their owners. ETSI claims no ownership of these except for any which are indicated as being the property of ETSI, and conveys no right to use or reproduce any trademark and/or tradename. Mention of those trademarks in the present document does not constitute an endorsement by ETSI of products, services or organizations associated with those trademarks.

DECT™, **PLUGTESTS™**, **UMTS™** and the ETSI logo are trademarks of ETSI registered for the benefit of its Members. **3GPP™** and **LTE™** are trademarks of ETSI registered for the benefit of its Members and of the 3GPP Organizational Partners. **oneM2M™** logo is a trademark of ETSI registered for the benefit of its Members and of the oneM2M Partners. **GSM®** and the GSM logo are trademarks registered and owned by the GSM Association.

Legal Notice

This Technical Specification (TS) has been produced by ETSI 3rd Generation Partnership Project (3GPP).

The present document may refer to technical specifications or reports using their 3GPP identities. These shall be interpreted as being references to the corresponding ETSI deliverables.

The cross reference between 3GPP and ETSI identities can be found under <https://webapp.etsi.org/key/queryform.asp>.

Modal verbs terminology

In the present document "**shall**", "**shall not**", "**should**", "**should not**", "**may**", "**need not**", "**will**", "**will not**", "**can**" and "**cannot**" are to be interpreted as described in clause 3.2 of the [ETSI Drafting Rules](#) (Verbal forms for the expression of provisions).

"**must**" and "**must not**" are **NOT** allowed in ETSI deliverables except when used in direct citation.

Contents

Intellectual Property Rights	2
Legal Notice	2
Modal verbs terminology.....	2
Foreword.....	6
1 Scope	7
2 References	8
3 Definitions, symbols and abbreviations	9
3.1 Definitions	9
3.2 Symbols.....	11
3.3 Abbreviations	11
4 Architecture considerations	13
4.1 High-level MMS architecture.....	13
4.2 MMS offline charging architecture	14
4.3 MMS online charging architecture.....	14
4.4 MMS converged charging architecture	15
5 MMS charging principles and scenarios	16
5.1 MMS charging principles	16
5.1.0 Introduction.....	16
5.1.1 Combined OOriginator and Recipient MMS R/S	17
5.1.2 Distributed Originator and Recipient MMS R/S.....	19
5.1.3 MMBox management	20
5.1.4 VASP transactions	21
5.2 MMS offline charging scenarios	23
5.2.1 Basic principles.....	23
5.2.2 Rf message flows	23
5.2.3 CDR generation	23
5.2.3.1 Combined Originator and Recipient MMS R/S case	24
5.2.3.2 Distributed Originator and Recipient MMS R/S case	24
5.2.3.3 MMBox related CDRs	24
5.2.3.4 CDRs related to VASP transactions.....	25
5.2.4 Ga record transfer flows	25
5.2.5 Bm CDR file transfer.....	25
5.3 MMS online charging scenarios	25
5.3.1 Basic principles.....	25
5.3.2 Ro message flows	25
5.3.2.0 General	25
5.3.2.1 MM submission.....	26
5.3.2.2 MM retrieval	27
5.3.2.3 MMS reports	28
5.3.2.3.1 Delivery report.....	28
5.3.2.3.2 Read report	28
5.4 MMS converged online and offline charging scenarios	28
5.4.1 Basic principles.....	28
5.4.1.1 General	28
5.4.1.2 Applicable Triggers in the MMS Node.....	29
5.4.1.2.1 General	29
5.4.1.3 CHF selection.....	30
5.4.2 Message flows	30
5.4.2.1 Introduction	30
5.4.2.2 MM submission.....	30
5.4.2.3 MM retrieval	31
5.4.3 CDR generation	34
5.4.3.1 Introduction.....	34

5.4.3.2	Triggers for CHF CDR.....	35
5.4.3.2.1	General	35
5.4.3.2.2	Triggers for CHF CDR generation	35
5.4.3.2.3	Triggers for CHF CDR opening	35
5.4.3.2.4	Triggers for CHF CDR closure	35
5.4.4	Ga record transfer flows	35
5.4.5	Bm CDR file transfer.....	35
6	Definition of charging information	36
6.0	General	36
6.1	Data description for MMS offline charging	36
6.1.0	Introduction.....	36
6.1.1	MMS records for Originator MMS R/S.....	37
6.1.1.0	General	37
6.1.1.1	Originator MM1 Submission record (O1S-CDR)	37
6.1.1.2	Originator MM4 Forward Request record (O4FRq-CDR).....	40
6.1.1.3	Originator MM4 Forward Response record (O4FRs-CDR).....	42
6.1.1.4	Originator MM4 Delivery Report record (O4D-CDR)	42
6.1.1.5	Originator MM1 Delivery Report record (O1D-CDR)	43
6.1.1.6	Originator MM4 Read Reply Report record (O4R-CDR).....	44
6.1.1.7	Originator MM1 Read Reply Originator record (O1R-CDR).....	45
6.1.1.8	Originator MM Deletion record (OMD-CDR).....	46
6.1.2	MMS records for Recipient MMS R/S	46
6.1.2.0	General	46
6.1.2.1	Recipient MM4 Forward record (R4F-CDR).....	47
6.1.2.2	Recipient MM1 Notification Request record (R1NRq-CDR).....	48
6.1.2.3	Recipient MM1 Notification Response record (R1NRs-CDR).....	49
6.1.2.4	Recipient MM1 Retrieve record (R1Rt-CDR)	50
6.1.2.5	Recipient MM1 Acknowledgement record (R1A-CDR).....	51
6.1.2.6	Recipient MM4 Delivery Report Request record (R4DRq-CDR)	51
6.1.2.7	Recipient MM4 Delivery Report Response record (R4DRs-CDR)	52
6.1.2.8	Recipient MM1 Read Reply Recipient record (R1RR-CDR)	52
6.1.2.9	Recipient MM4 Read Reply Report Request record (R4RRq-CDR).....	53
6.1.2.10	Recipient MM4 Read Reply Report Response record (R4RRs-CDR).....	53
6.1.2.11	Recipient MM1 Cancellation record (R1C-CDR).....	54
6.1.2.12	Recipient MM Deletion record (RMD-CDR)	54
6.1.3	MMS records for Forwarding MMS R/S	55
6.1.3.1	Forwarding record (F-CDR).....	55
6.1.4	Service records for MMS R/S supporting MMBoxes	56
6.1.4.1	MMBox MM1 Store record (Bx1S-CDR)	56
6.1.4.2	MMBox MM1 View record (Bx1V-CDR)	57
6.1.4.3	MMBox MM1 Upload record (Bx1U-CDR)	58
6.1.4.4	MMBox MM1 Delete record (Bx1D-CDR).....	58
6.1.5	MMS records for MMS VAS applications	59
6.1.5.0	General	59
6.1.5.1	MM7 Submission record (MM7S-CDR)	59
6.1.5.2	MM7 Deliver Request record (MM7DRq-CDR).....	61
6.1.5.3	MM7 Deliver Response record (MM7DRs-CDR)	61
6.1.5.4	MM7 Cancel record (MM7C-CDR)	62
6.1.5.5	MM7 Replace record (MM7R-CDR).....	62
6.1.5.6	MM7 Delivery Report Request record (MM7DRRq-CDR).....	63
6.1.5.7	MM7 Delivery Report Response record (MM7DRRs-CDR).....	63
6.1.5.8	MM7 Read Reply Report Request record (MM7RRq-CDR).....	64
6.1.5.9	MM7 Read Reply Report Response record (MM7RRs-CDR).....	64
6.1.5.10	MM7 Extended Cancel record (MM7EC-CDR)	65
6.1.5.11	MM7 Extended Replace record (MM7ER-CDR)	65
6.2	Data description for MMS online charging	66
6.2.1	Ro message contents	66
6.2.1.0	General	66
6.2.1.1	Debit / Reserve Units Request message	66
6.2.1.2	Debit / Reserve Units Response message.....	67
6.2a	Data description for MMS converged charging	67

6.2a.1	Message contents	67
6.2a.1.1	General	67
6.2a.1.2	Structure for the converged charging message formats.....	68
6.2a.1.2.1	Charging Data Request message	68
6.2a.1.2.2	Charging Data Response message	69
6.3	MMS charging specific parameters	70
6.3.0	General.....	70
6.3.1	MMS charging information assignment for Service Information.....	70
6.3.2	Definition of the MMS Information	71
6.3.3	Detailed message format for online charging	72
6.3.4	Formal MMS charging parameter description	72
6.3.4.1	MMS charging information for CDRs	72
6.3.4.2	MMS charging information for charging events	72
6.4	Definition of the MMS converged charging information	72
6.4.1	General.....	72
6.4.2	Definition of MMS charging information.....	73
6.4.3	Detailed message format for converged charging	74
6.4.4	Formal MMS converged charging parameter description.....	76
6.4.4.1	MMS charging CHF CDR parameters	76
6.4.4.2	MMS charging resources attributes.....	76
6.5	Bindings for MMS converged charging	76
Annex A (informative): Bibliography		77
Annex B (informative): Change history		78
History		79

Foreword

This Technical Specification has been produced by the 3rd Generation Partnership Project (3GPP).

The contents of the present document are subject to continuing work within the TSG and may change following formal TSG approval. Should the TSG modify the contents of the present document, it will be re-released by the TSG with an identifying change of release date and an increase in version number as follows:

Version x.y.z

where:

- x the first digit:
 - 1 presented to TSG for information;
 - 2 presented to TSG for approval;
 - 3 or greater indicates TSG approved document under change control.
- y the second digit is incremented for all changes of substance, i.e. technical enhancements, corrections, updates, etc.
- z the third digit is incremented when editorial only changes have been incorporated in the document.

1 Scope

The present document is part of a series of Technical Specifications (TSs) that specify charging functionality and charging management in GSM/UMTS networks. The GSM/UMTS core network charging architecture and principles are specified in document TS 32.240 [1], which provides an umbrella for other charging management documents that specify:

- the content of the CDRs per domain and subsystem (offline charging);
- the content of real-time charging messages per domain / subsystem (online charging);
- the functionality of online and offline charging for those domains and subsystems;
- the interfaces that are used in the charging framework to transfer the charging information (i.e. CDRs or charging events).

The complete document structure for these TSs is defined in TS 32.240 [1].

The present document specifies the offline and online charging description for MMS charging, based on the functional stage 2 descriptions of the MMS in TS 23.140 [201]. This charging description includes the offline and online charging architecture and scenarios specific to the MMS, as well as the mapping of the common 3GPP charging architecture specified in TS 32.240 [1] onto MMS. It further specifies the structure and content of the CDRs for offline charging, and the charging events for online charging. The present document is related to other 3GPP charging TSs as follows:

- The common 3GPP charging architecture is specified in TS 32.240 [1];
- The parameters, abstract syntax and encoding rules for these CDR types are specified in TS 32.298 [51].
- A transaction based mechanism for the transfer of CDRs within the network is specified in TS 32.295 [54].
- The file based mechanism used to transfer the CDRs from the network to the operator's billing domain (e.g. the billing system or a mediation device) is specified in TS 32.297 [52].
- The 3GPP Diameter application that is used for MMS online charging is specified in TS 32.299 [50].

All terms, definitions and abbreviations used in the present document, that are common across 3GPP TSs, are defined in the 3GPP Vocabulary, TR 21.905 [100]. Those that are common across charging management in GSM/UMTS domains, services or subsystems are provided in the umbrella document TS 32.240 [1] and are copied into clause 3 of the present document for ease of reading. Finally, those items that are specific to the present document are defined exclusively in the present document.

Furthermore, requirements that govern the charging work are specified in TS 22.115 [101].

2 References

The following documents contain provisions, which through reference in this text, constitute provisions of the present document.

- References are either specific (identified by date of publication, edition number, version number, etc.) or non-specific.
- For a specific reference, subsequent revisions do not apply.
- For a non-specific reference, the latest version applies. In the case of a reference to a 3GPP document (including a GSM document), a non-specific reference implicitly refers to the latest version of that document *in the same Release as the present document*.

- [1] 3GPP TS 32.240: "Telecommunication management; Charging management; Charging Architecture and Principles".
- [2] 3GPP TS 32.290: "Telecommunication management; Charging management; 5G system; Services, operations and procedures of charging using Service Based Interface (SBI)". [3] - [9]Void.
- [10] 3GPP TS 32.250: "Telecommunication management; Charging management; Circuit Switched (CS) domain charging".
- [11] 3GPP TS 32.251: "Telecommunication management; Charging management; Packet Switched (PS) domain charging".
- [12] - [33] Void.
- [34] 3GPP TS 32.274: "Telecommunication management; Charging management; Short Message Service (SMS) charging".
- [35] - [49] Void.
- [50] 3GPP TS 32.299: "Telecommunication management; Charging management; Diameter charging application".
- [51] 3GPP TS 32.298: "Telecommunication management; Charging management; Charging Data Record (CDR) parameter description".
- [52] 3GPP TS 32.297: "Telecommunication management; Charging management; Charging Data Records (CDR) file format and transfer".
- [53] 3GPP TS 32.296: "Telecommunication management; Charging management; Online Charging System (OCS) applications and interfaces".
- [54] 3GPP TS 32.295: "Telecommunication management; Charging management; Charging Data Record (CDR) transfer".
- [55] - [99] Void.
- [100] 3GPP TR 21.905: "Vocabulary for 3GPP Specifications".
- [101] 3GPP TS 22.115: "Service aspects; Charging and billing".
- [102] - [199] Void.
- [200] 3GPP TS 22.140: "Multimedia Messaging Service (MMS); Stage 1".
- [201] 3GPP TS 23.140: "Multimedia Messaging Service (MMS); Functional description; Stage 2".
- [202] 3GPP TS 24.002: "GSM - UMTS Public Land Mobile Network (PLMN) Access Reference Configuration".
- [203] - [399] Void.
- [400] Void.

- [401] OMA SpecWorks: "OMA Multimedia Messaging Service - MMS"
<https://omaspecworks.org/>
- [402] IETF RFC 4006 (2005): "Diameter Credit-Control Application".

3 Definitions, symbols and abbreviations

3.1 Definitions

For the purposes of the present document, the following terms and definitions given in TR 21.905 [50], TS 32.240 [1] and TS 22.140 [200] and the following apply:

accounting: process of apportioning charges between the Home Environment, Serving Network and subscriber.

application data: Information / data specific to an application other than the MMS User Agent / VASP which is intended to be transported without alteration by using MMS. Application Data may be of any content type and format.

billing: function whereby CDRs generated by the charging function(s) are transformed into bills requiring payment.

Billing Domain: part of the operator network, which is outside the telecommunications network, that receives and processes CDR files from the network charging functions. It includes functions that can provide billing mediation and billing or other (e.g. statistical) end applications. It is only applicable to offline charging (see "Online Charging System" for equivalent functionality in online charging).

chargeable event: activity utilizing telecommunications network resources and related services for:

- user to user communication (e.g. a single call, a data communication session or a short message); or
- user to network communication (e.g. service profile administration); or
- inter-network communication (e.g. transferring calls, signalling, or short messages); or
- mobility (e.g. roaming or inter-system handover); and
- that the network operator may want to charge for.

As a minimum, a chargeable event characterises the resource / service usage and indicates the identity of the involved end user(s).

charged party: user involved in a chargeable event who has to pay parts or the whole charges of the chargeable event, or a third party paying the charges caused by one or all users involved in the chargeable event, or a network operator.

charging: a function within the telecommunications network and the associated OCS/BD components whereby information related to a chargeable event is collected, formatted, transferred and evaluated in order to make it possible to determine usage for which the charged party may be billed.

Charging Data Record (CDR): a formatted collection of information about a chargeable event (e.g. time of call set-up, duration of the call, amount of data transferred, etc) for use in billing and accounting. For each party to be charged for parts of or all charges of a chargeable event a separate CDR shall be generated, i.e. more than one CDR may be generated for a single chargeable event, e.g. because of its long duration, or because more than one charged party is to be charged.

charging event: a set of charging information forwarded by the CTF towards the CDF (offline charging) or towards the OCS (online charging). Each charging event matches exactly one chargeable event.

charging function: entity inside the network domain, subsystem or service that is involved in charging for that domain, subsystem or service.

circuit switched domain: domain within GSM / UMTS in which information is transferred in circuit switched mode.

Credit-Control: mechanism which directly interacts in real-time with an account and controls or monitors the charges, related to the service usage. Credit-Control is a process of: checking if credit is available, credit reservation, deduction of credit from the end user account when service is completed and refunding of reserved credit not used.

delivery report: feedback information provided to an originator MMS User Agent by an MMS Relay/Server about the status of the delivery of an MM.

domain: part of a communication network that provides network resources using a certain bearer technology.

forwarded MM: MM originally sent from a sender to an intended recipient which is then forwarded to other recipient(s) and to which a delivery report and/or read-reply report may refer and which may be subject to further forwarding.

forwarding MMS User Agent: MMS User Agent that is the intended recipient of an MM and that requests forwarding of the MM for delivery to other recipient(s) without having to first download the MM.

Fully Qualified Partial CDR (FQPC): partial CDR that contains a complete set of the fields specified in the present document. This includes all the mandatory and conditional fields as well as those fields that the PLMN operator has provisioned to be included in the CDR. The first Partial CDR shall be a Fully qualified Partial CDR.

message ID: unique identifier for an MM.

middle tier TS: used for the 3GPP charging TSs that specify the domain / subsystem / service specific, online and offline, charging functionality. These are all the TSs in the numbering range from TS 32.250 [10] to TS 32.27x [3x], e.g. TS 32.250 [10] for the CS domain, or TS 32.270 [30] for the MMS service. Currently, there is only one "tier 1" TS in 3GPP, which is TS 32.240 [1] that specifies the charging architecture and principles. Finally, there are a number of top tier TSs in the 32.29x numbering range ([50] ff) that specify common charging aspects such as parameter definitions, encoding rules, the common Billing Domain interface or common charging applications.

MMSE: collection of MMS-specific elements under the control of a single administration.

MMS Relay/Server (MMS R/S): MMS-specific network entity/application that is under the control of an MMS service provider.

An MMS relay/server transfers messages, provides operations of the MMS that are specific to or required by the mobile environment and provides (temporary and/or persistent) storage services to the MMS.

MMS User Agent: application residing on a user equipment, a mobile station or an external device that performs MMS-specific operations on a user's behalf and/or on another application's behalf. An MMS User Agent is not considered part of an MMSE.

near real-time: near real-time charging and billing information is to be generated, processed, and transported to a desired conclusion in less than one (1) minute.

offline charging: charging mechanism where charging information **does not** affect, in real-time, the service rendered.

online charging: charging mechanism where charging information can affect, in real-time, the service rendered and therefore a direct interaction of the charging mechanism with bearer/session/service control is required.

Online Charging System: the entity that performs real-time Credit-Control. Its functionality includes transaction handling, rating, online correlation and management of subscriber accounts/balances.

original MM: (initial) MM sent from a sender to a recipient and to which a delivery report and/or a read-reply report and/or a reply-MM may refer and/or which may be subject to being forwarded.

originator MMS User Agent: an MMS User Agent associated with the sender of an MM.

packet switched domain: domain within GSM / UMTS in which data is transferred in packet switched mode. Corresponds to the term "GPRS".

partial CDR: CDR that provides information on part of a subscriber session. A long session may be covered by several partial CDRs. Two formats are considered for Partial CDRs. One that contains all of the specified fields (FQPC); the second has a reduced format (RPC).

read-reply report: feedback information to an originator MMS User Agent by a Recipient MMS User Agent about the status of handling/rendering of an original MM in a Recipient MMS User Agent.

real-time: real-time charging and billing information is to be generated, processed, and transported to a desired conclusion in less than one (1) second.

Recipient MMS User Agent: MMS User Agent associated with the recipient of an MM.

reply-MM: in case of reply-charging the first reply accepted by the Recipient MMS Relay/Server (after checking the reply charging limitations, such as the latest time of submission) is called a reply-MM.

settlement: payment of amounts resulting from the accounting process.

subscriber: a subscriber is an entity (associated with one or more users) that is engaged in a subscription with a service provider. The subscriber is allowed to subscribe and unsubscribe services, to register a user or a list of users authorized to enjoy these services, and also to set the limits relative to the use that associated users make of these services.

user: an entity, not part of the 3GPP System, that uses network resources by means of a subscription. The user may or may not be identical to the subscriber holding that subscription.

User Equipment (UE): a device allowing a user access to network services. For the purpose of 3GPP specifications the interface between the UE and the network is the radio interface. A User Equipment can be subdivided into a number of domains, the domains being separated by reference points. Currently defined domains are the USIM and ME Domains. The ME Domain can further be subdivided into several components showing the connectivity between multiple functional groups. These groups can be implemented in one or more hardware devices. An example of such a connectivity is the TE – MT interface. Further, an occurrence of a User Equipment is an MS for GSM as defined in TS 24.002 [202].

3.2 Symbols

For the purposes of the present document, the following symbols apply:

Ci	Charging Trigger in combined MMS Relay/Server.
Bm	Reference point for the CDR file transfer from the MMS CGF to the BD.
Mi	Charging Trigger in MMS Relay/Server for MMBBox Management.
MM1	The reference point between the MMS User Agent and the MMS Relay/Server.
MM2	The reference point between the MMS Relay and the MMS Server.
MM3	The reference point between the MMS Relay/Server and external (legacy) messaging systems.
MM4	The reference point between the MMS Relay/Server and another MMS Relay/Server that is within another MMSE.
MM5	The reference point between the MMS Relay/Server and the Home Location Register (HLR).
MM6	The reference point between the MMS Relay/Server and the MMS User Databases.
MM7	The reference point between the MMS Relay/Server and MMS VAS Applications.
MM8	The reference point between the MMS Relay/Server and the post-processing system.
MM9	The reference point between the MMS Relay/Server and the online charging system.
MM10	The reference point between the MMS Relay/Server and a Messaging Service Control Function (MSCF).
Oi	Charging Trigger in Originator MMS Relay/Server.
Ri	Charging Trigger in Recipient MMS Relay/Server.

3.3 Abbreviations

For the purposes of the present document, the abbreviations defined in TR 21.905 [50], TS 23.140 [201], TS 32.240 [1] and the following apply:

3G	3 rd Generation
3GPP	3 rd Generation Partnership Project
AVP	Attribute Value Pair
BD	Billing Domain
CCA	Credit Control Answer
CCR	Credit Control Request
CDF	Charging Data Function
CDR	Charging Data Record
CGF	Charging Gateway Function
CS	Circuit Switched
CTF	Charging Trigger Function
DCCA	Diameter Credit Control Application
EBCF	Event Based Charging Function
ECUR	Event Charging with Unit Reservation
FTAM	File Transfer, Access and Management

GPRS	General Packet Radio Service
GSM	Global System for Mobile communication
HLR	Home Location Register
IE	Information Element
IEC	Immediate Event Charging
IETF	Internet Engineering Task Force
IMS	IP Multimedia Subsystem
IMSI	International Mobile Subscriber Identity
IP	Internet Protocol
ITU-T	International Telecommunication Union - Telecommunications standardization sector
LCS	LoCation Service
MCC	Mobile Country Code (part of IMSI)
ME	Mobile Equipment
MIME	Multipurpose Internet Mail Extensions
MM	Multimedia Message
MMS	Multimedia Messaging Service
MMSE	Multimedia Messaging Service Element
MMSNA	Multimedia Messaging Service Network Architecture
MMSO	Multimedia Messaging Service Originator
MMSR	Multimedia Messaging Service Recipient
MMS R/S	Multimedia Messaging Relay/Server
MNC	Mobile Network Code (part of IMSI)
MO	Mobile Originated
MS	Mobile Station
MSCF	Messaging Service Control Function
MT	Mobile Terminated
NE	Network Element
OCS	Online Charging System
PLMN	Public Land Mobile Network
PS	Packet-Switched
RPC	Reduced Partial CDR
SCCP	Signalling Connection Control Part
TR	Technical Report
TS	Technical Specification
UA	User Agent
UE	User Equipment
UMTS	Universal Mobile Telecommunications System
USIM	User Service Identity Module
VAS	Value Added Service
VASP	Value Added Service Provider

4 Architecture considerations

4.1 High-level MMS architecture

Figure 4.1.1 depicts the MMS reference architecture, as described in TS 23.140 [201].

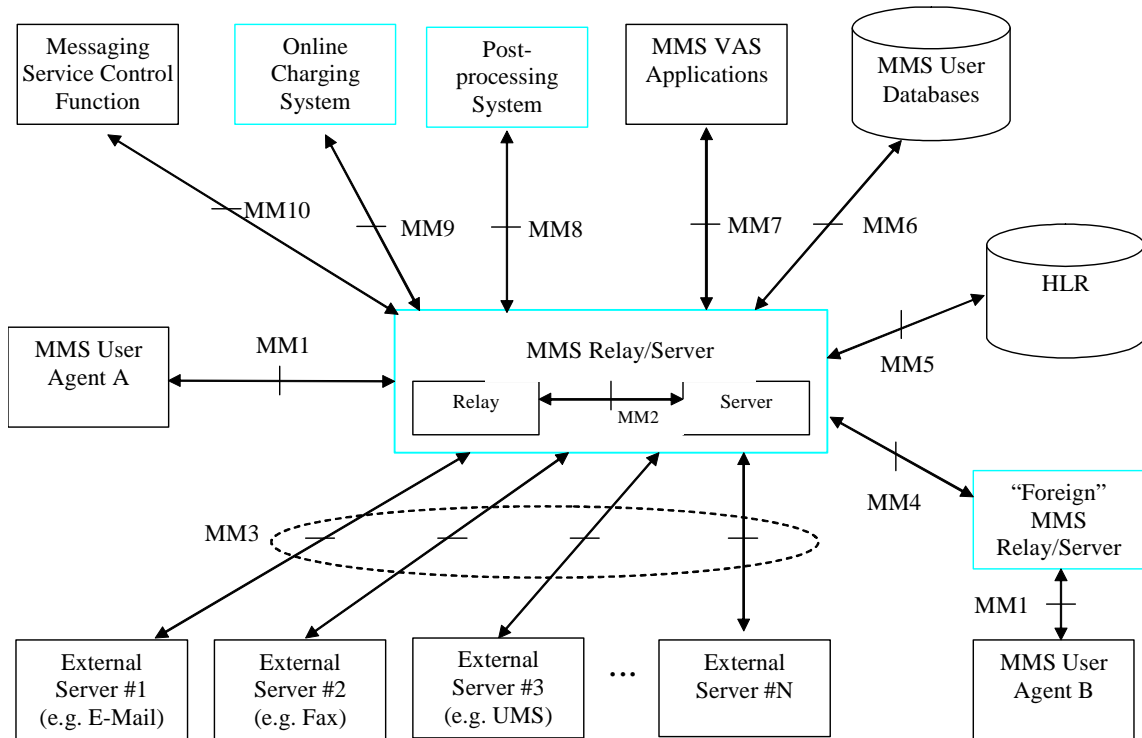

Figure 4.1.1: MMS reference architecture

As can be seen in figure 4.1.1, the following MMS elements are relevant for charging:

- MMS Relay/Server (MMS R/S),
- "Foreign" MMS Relay/Server (MMS R/S).

4.2 MMS offline charging architecture

As described in TS 32.240 [1], the CTF (an integrated component in each charging relevant NE) generates charging events and forwards them to the CDF. The CDF, in turn, generates CDRs which are then transferred to the CGF. Finally, the CGF creates CDR files and forwards them to the Billing Domain (BD).

In MMS, all charging functions (CTF, CDF and CGF) reside within the MMS R/S. I.e. the MMS R/S is connected directly to the BD via the Bm interface. Bm is the MMS specific variant of the common Bx interface and is functionally equivalent to MM8. This architecture implies that there exists no separate CDF and CGF for MMS, i.e. no corresponding open interfaces between any such functions, within the 3GPP standards.

Figure 4.2.1 depicts the mapping of the 3GPP common charging architecture, as laid down in TS 32.240 [1], onto the MMS.

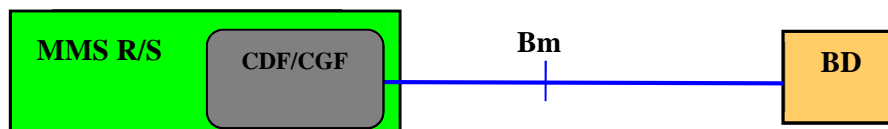

Figure 4.2.1: MMS offline charging architecture

In addition to the standard approach depicted in figure 4.2.1, vendors may choose to implement separate CDF and CGF for MMS. In that case, the interfaces between these functions should comply with the definition of the Rf and Ga interfaces (TS 32.299 [50] and TS 32.295 [54], respectively) as much as possible.

4.3 MMS online charging architecture

MMS online charging is based on MMS R/S functionality that is further specified in the present document. For online charging, the MMS R/S utilizes the Ro interface and application towards the OCS as specified in TS 32.299 [50]. The Ro reference point covers all online charging functionality required for MMS, i.e. it is functionally equivalent to the MM9 reference point.

The MMS online charging architecture is depicted in figure 4.3.1.

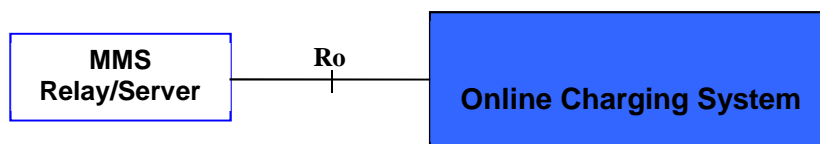

Figure 4.3.1: MMS online charging architecture

Details on the interfaces and functions can be found in TS 32.240 [1] for the general architecture components, TS 32.296 [53] for the OCS, and 32.299 [50] for the Ro application.

4.4 MMS converged charging architecture

The architectural options for MMS converged charging are depicted in figure 4.4.1 in service-based representation for CHF:

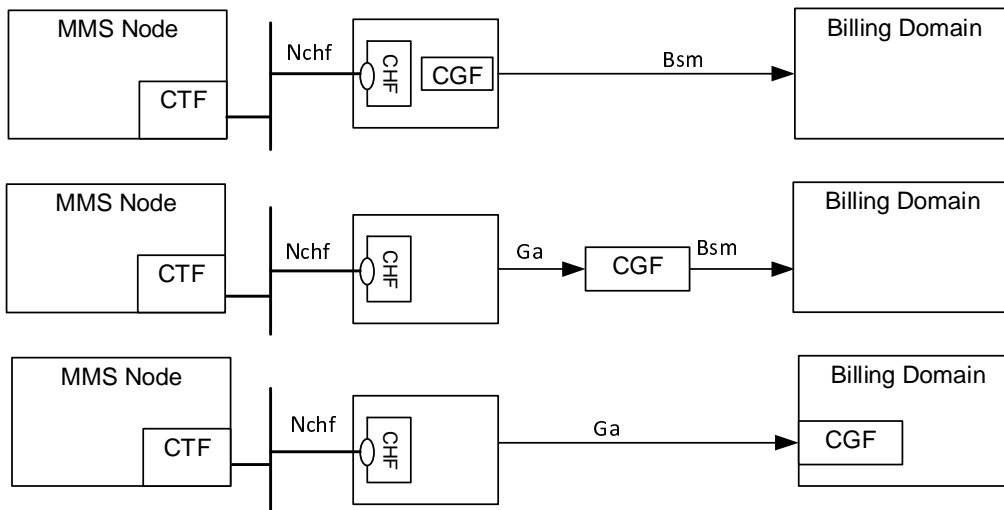

Figure 4.4.1: MMS converged charging architecture

Architectural options of figure 4.4.1 apply to any MMS converged charging architecture of this clause. The MMS Node correspond to MMS relay/server as defined in TS 23.140 [201].

The general architecture components can be found in TS 32.240 [1].

Bm in clause 5.2.5 of this document, and Nchf is described in TS 32.290 [2].

Figure 4.4.2 depicts the MMS converged charging architecture for non-roaming in reference point representation:

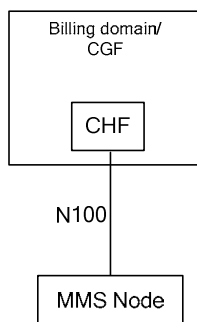

Figure 4.4.2: MMS converged charging architecture non-roaming reference point representation

5 MMS charging principles and scenarios

5.1 MMS charging principles

5.1.0 Introduction

The MMS R/S collects charging information for each MM transaction that crosses the relevant reference points defined in TS 22.140 [200]. The chargeable events that trigger the collection of charging information on the applicable reference points are identical for MMS offline and online charging and are specified below. The use of the events to generate CDRs (offline charging) or Credit-Ccontrol requests (online charging) are described in clause 5.2 for offline charging and in clause 5.3 for online charging, respectively.

In line with the requirements laid down in TS 22.140 [200] and TS 23.140 [201] the MMS R/S collects charging information such as:

- the destination and source addresses applied for an MM;
- identification of the MMS R/S(s) involved in the MM transaction;
- the amount and type of user data transmitted in MO and MT directions for the transfer of MM; i.e. the size of the MM and its components;
- storage duration; i.e. the time interval when a MM is saved on a non-volatile memory media;
- identification of the bearer resources used for the transport of the MM; i.e. the identity of the network and the network nodes;
- in scenarios involving a VASP, the charging information describes the identification of the VASP and the amount of user data sent and received between the MMS R/S and the VASP.
- in scenarios involving the MSCF, additional information supplied by the MSCF.

The information listed above is captured for use cases in relation to:

- MM submission;
- MM retrieval;
- MM forwarding;
- transactions involving the MMbox;
- transactions involving a VASP.

Refer to TS 23.140 [201] for further details on the above MM transactions.

The following scenarios can be distinguished in MMS charging:

- Combined Originator and Recipient MMS R/S. This scenario covers the case where the Originator MMS R/S and the Recipient MMS R/S are identical, which implies that that particular MMS R/S handles both MM submission and MM retrieval.
- Distributed Originator and Recipient MMS R/S. This scenario covers the case of the Originator MMS R/S and the Recipient MMS R/S being two different entities, where the Originator MMS R/S handles MM submission and the Recipient MMS R/S handles MM retrieval.
- MMBox management. MMBox is a logical entity of the MMS R/S that allow to support the persistent network-based storage of the MMs. This feature is an extension of the MM1 interface that enables a MMS User Agent to store, retrieve and delete incoming and submitted MMs.
- VASP transactions. MMS VAS Application offers value added services to the MMS Users. The MMS VASP are able to interact with the MMS R/S via the MM7 interface using transactions similar to those of the MM1 interface i.e. submission, reception, delivery-report, read-reply report, etc.

These scenarios all pertain to atomic actions related to MMs, e.g. submission, retrieval, storage, deletion, etc., implying that MMS only uses event based charging, as specified in TS 32.240 [1] (i.e. session based charging is not applicable for MMS). The following subclauses further describe the above scenarios and illustrate the conditions for the various types of chargeable events based on MMs crossing the reference points identified in TS 23.140 [201] (MM1, MM4 and MM7). The labels in the message flows identify the chargeable events in relation to the particular reference point.

5.1.1 Combined OOriginator and Recipient MMS R/S

This scenario, as depicted in figure 5.1.1.1, covers the case where the Originator MMS R/S and the Recipient MMS R/S are identical, which implies that that particular MMS R/S handles both MM submission and MM retrieval.

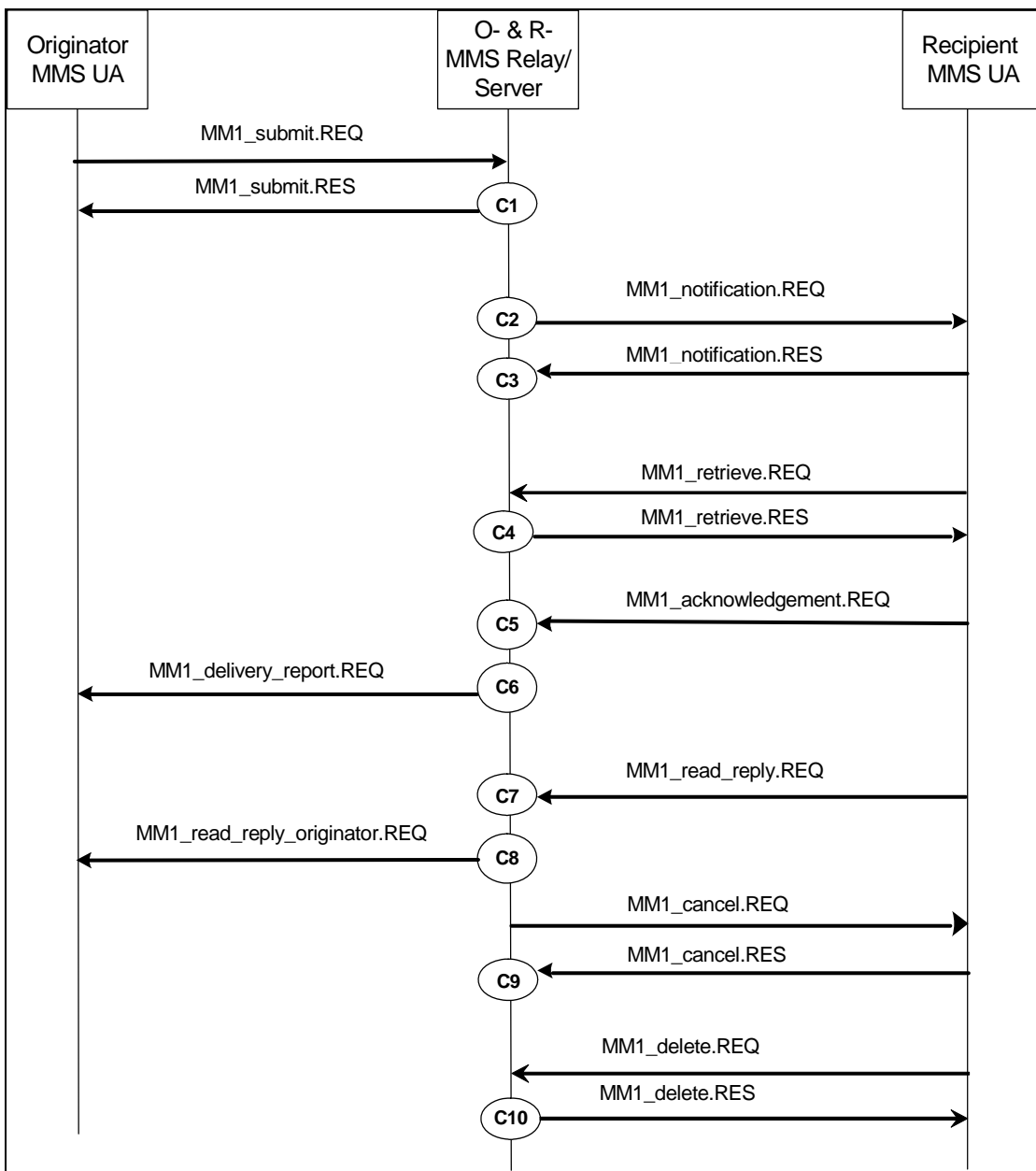

Figure 5.1.1.1: Chargeable event overview for combined case

Table 5.1.1.2: Trigger point overview for combined MMS R/S

Trigger point	Trigger name
C1	Originator MM1 Submission
C2	Recipient MM1 Notification Request
C3	Recipient MM1 Notification Response
C4	Recipient MM1 Retrieval
C5	Recipient MM1 Acknowledgement
C6	Originator MM1 Delivery Report
C7	Recipient MM1 Read Reply Recipient
C8	Originator MM4 Read Reply Originator
C9	Recipient MM1 Cancellation (see note 2)
C10	Recipient MM1 Deletion
Any time between C1 to C8	Originator MM Deletion
NOTE 1:	Chargeable events for MM submission, retrieval and cancellation are triggered by the MMS R/S responding to MM1_submit.REQ and MM1_retrieve.REQ, rather than upon receiving those requests and receiving a response to MM1_Cancel.RES rather than upon submitting this request
NOTE 2:	MM1 Cancellation is triggered by receiving an MM7_extended_cancel.REQ.

5.1.2 Distributed Originator and Recipient MMS R/S

This scenario, as depicted in figure 5.1.2.1, covers the case of the Originator MMS R/S and the Recipient MMS R/S being two different entities, where the Originator MMS R/S handles MM submission and the Recipient MMS R/S handles MM retrieval.

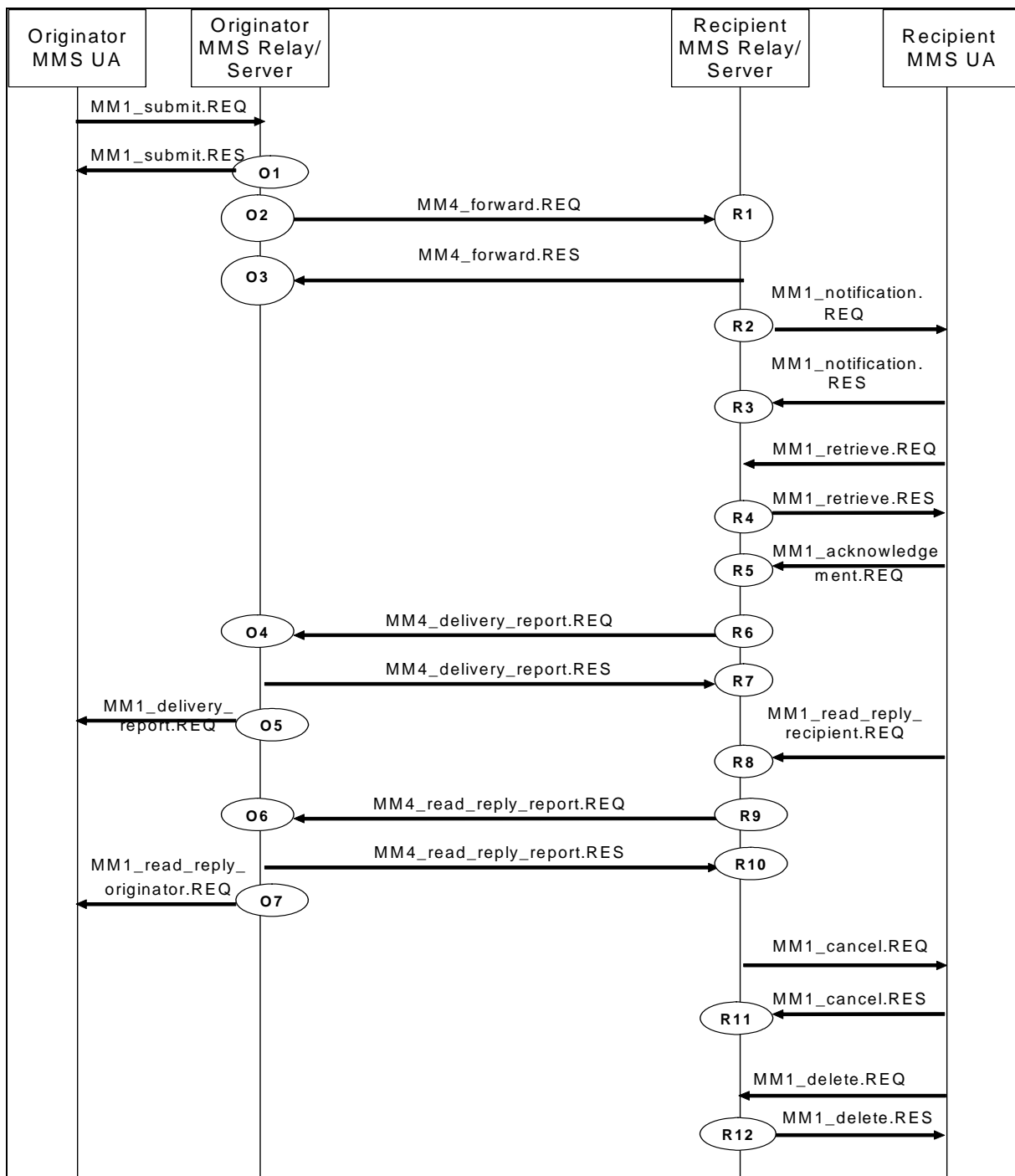

Figure 5.1.2.1: Chargeable event overview for distributed case

Table 5.1.2.2 : Trigger type overview for the Originator MMS R/S

Trigger point	Trigger name
O1	Originator MM1 Submission
O2	Originator MM4 Forward Request
O3	Originator MM4 Forward Response
O4	Originator MM4 Delivery Report
O5	Originator MM1 Delivery Report
O6	Originator MM4 Read Reply Report
O7	Originator MM1 Read Reply Originator
Any time between O1... O7	Originator MM Deletion
NOTE:	Chargeable events for MM submission are triggered by the MMS R/S responding to MM1_submit.REQ, rather than upon receiving those requests.

Table 5.1.2.3: Trigger type overview for the Recipient MMS R/S

Trigger point	Trigger name
R1	Recipient MM4 Forward
R2	Recipient MM1 Notification Request
R3	Recipient MM1 Notification Response
R4	Recipient MM1 Retrieval
R5	Recipient MM1 Acknowledgement
R6	Recipient MM4 Delivery Report Request
R7	Recipient MM4 Delivery Report Response
R8	Recipient MM1 Read Reply Recipient
R9	Recipient MM4 Read Reply Report Request
R10	Recipient MM4 Read Reply Report Response
R11	Recipient MM1 Cancellation (see note 2)
R12	Recipient MM1 Deletion
Anytime after R2	Recipient MM Deletion
NOTE 1:	Chargeable events for MM retrieval and cancellation are triggered by the MMS R/S responding to MM1_retrieve.REQ, rather than upon receiving those requests and receiving a response to MM1_Cancel.RES rather than upon submitting this request
NOTE 2:	MM1 Cancellation is triggered by receiving an MM7_extended_cancel.REQ.

5.1.3 MMBox management

MMBox is a logical entity of the MMS R/S that allows to support the persistent network-based storage of the MMs. This feature is an extension of the MM1 interface that enables the MMS User Agent to store, retrieve and delete

incoming and submitted MMs. For further detailed description of "Persistent Network-Based Storage" see TS 23.140 [201].

This scenario, as depicted in figure 5.1.3.1, covers the MM transactions related to MMBox usage and the associated chargeable events in the affected MMS R/S.

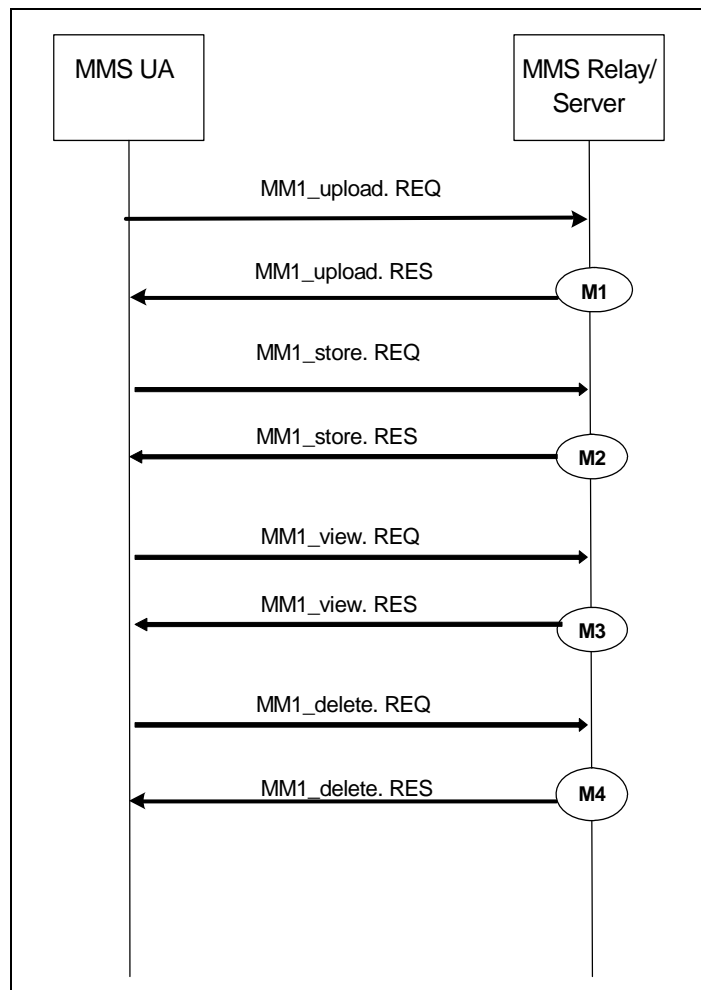

Figure 5.1.3.1: Chargeable event overview for MMBox management

Table 5.1.3.2: Trigger type overview for MMBox management

Trigger point	Trigger name
M1	MMBox MM1 Upload
M2	MMBox MM1 Store
M3	MMBox MM1 View
M4	MMBox MM1 Delete
NOTE: Chargeable events for MM Upload, Store, View and Delete are triggered by the MMS R/S responding to these requests, rather than upon receiving them.	

5.1.4 VASP transactions

MMS VAS Application offers value added services to the MMS Users. The MMS VASP are able to interact with the MMS R/S via the MM7 reference point using transactions similar to those of the MM1 interface i.e. submission, reception, delivery-report, read-reply report, etc.

The VASP may provide service codes that contain billing information which may be transferred to the MMS R/S and passed directly to the billing system without intervention. In addition, the VASP may provide an indication to the MMS

R/S which party is expected to be charged for an MM submitted by the VASP, e.g. the sending, receiving, both parties or neither.

This scenario, as depicted in figure 5.1.4.1, covers the VASP related MM transactions and the associated chargeable events in the affected MMS R/S.

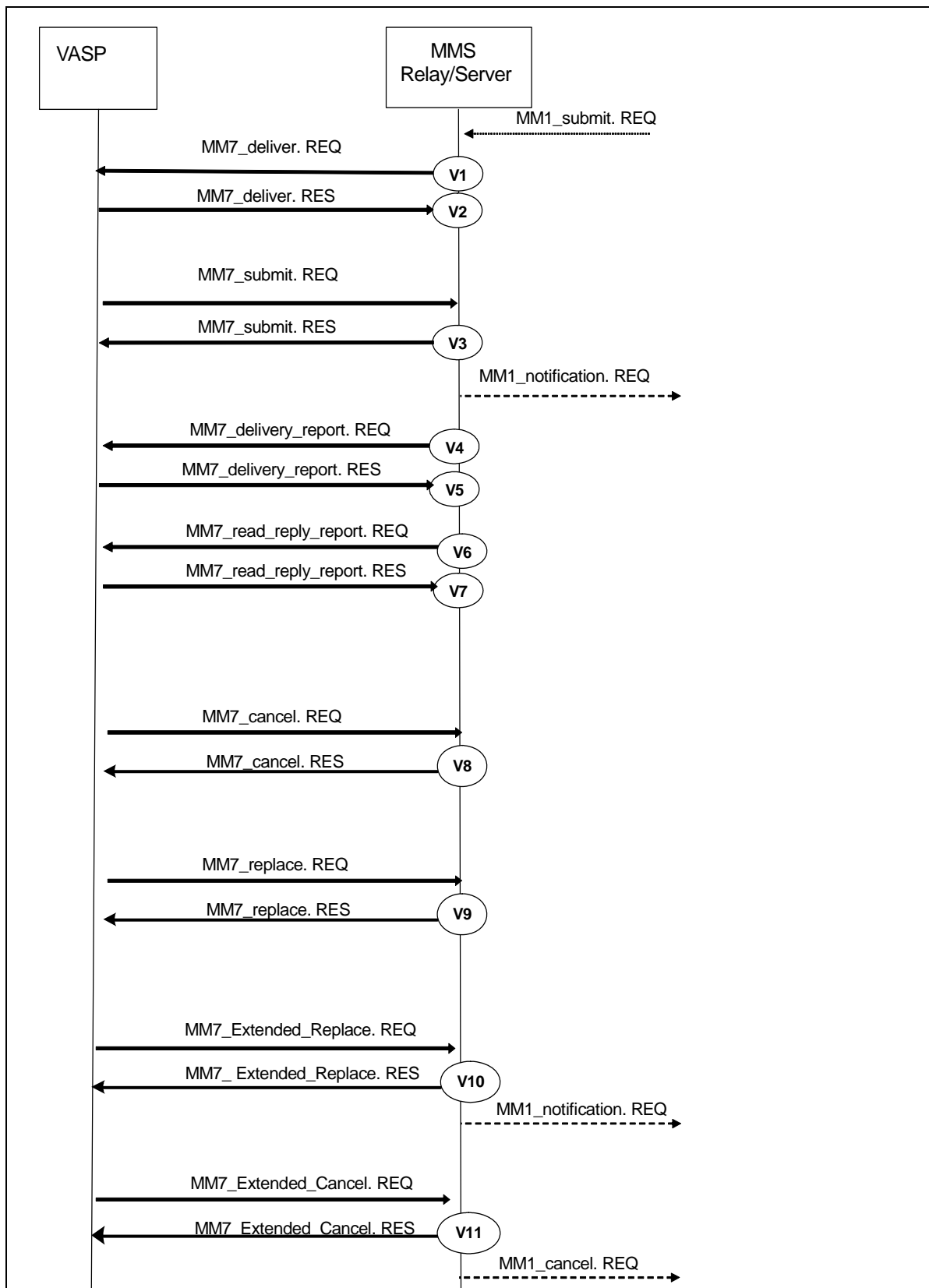

Figure 5.1.4.1: Chargeable event overview for VASP transactions

Table 5.1.4.2: Trigger type overview for VASP transactions

Trigger point	Trigger name
V1	MM7 Deliver Request
V2	MM7 Deliver Response
V3	MM7 Submission
V4	MM7 Delivery Report Request
V5	MM7 Delivery Report Response
V6	MM7 Read Reply Report Request
V7	MM7 Read Reply Report Response
V8	MM7 Replacement
V9	MM7 Cancellation
V10	MM7 Extended Replacement
V11	MM7 Extended Cancellation
NOTE:	Chargeable events for MM7 submission, replacement and cancellation are triggered by the MMS R/S responding to these requests, rather than upon receiving them.

5.2 MMS offline charging scenarios

5.2.1 Basic principles

MMS offline charging implies the generation of CDRs of various types by the involved MMS R/S(s). As explained in clause 5.1, only event based charging applies to MMS, i.e. there is no use of session based charging in the MMS R/S. In line with the principles for event based charging laid down in TS 32.240 [1], the relationship between chargeable events and charging events is 1:1, and the relationship between charging events and CDRs is also 1:1.

The chargeable event triggers are defined in clause 5.1.1 to 5.1.4 above and are identified by the labels within the figures 5.1 to 5.4 (message flows) in relation to the particular MMS reference point. As can be seen from these figures, the chargeable events relate to transactions at the MM1, MM4 and MM7 reference points.

An open Rf or Ga interface is not specified for MMS in the 3GPP standards, hence no charging events (Rf message flows) are specified in clause 5.2.2.

In clause 5.2.3, CDR generation is described in relation to the chargeable event triggers specified in clause 5.1, given that there is a 1:1 relation all the way from chargeable event to CDR type as explained in the first paragraph above. However, due to the absence of a standard Ga interface for MMS, from the 3GPP specifications perspective these CDRs are only visible in CDR files crossing the Bm interface.

5.2.2 Rf message flows

Not applicable, as the separation of the CTF and CDF is not in the scope of the MMS charging standards. Refer to clause 4.2 for further information.

NOTE: Vendors may nevertheless implement a separate CTF and CDF for MMS charging. In this case, it is recommended that the approach chosen conforms to the principles and protocol applications specified in TS 32.299 [50].

5.2.3 CDR generation

For MMS, the Ga interface is not applicable, as the separation of the CDF and CGF is not in the scope of the MMS charging specifications. I.e. the following CDR types are visible only in the CDR files transferred from the MMS R/S embedded CGF to the BD via the Bm interface.

NOTE: If vendors choose to implement the Ga interface for MMS, then it is recommended that the approach chosen conforms with the CDRs specified in this section and the Ga protocol conventions laid down in TS 32.295 [54].

5.2.3.1 Combined Originator and Recipient MMS R/S case

The chargeable events for the case of a combined Originator and Recipient MMS R/S are depicted in figure 5.1.1.1 and further listed in table 5.1.1.1. Due to the fact that only event based charging applies to MMS (see clause 5.2.1), these chargeable events translate 1:1 into the CDR types listed in table 5.2.3.1.1 below.

The first row in table 5.2.3.1.1 refers to the trigger labels in figure/table 5.1.1.1.

The second row identifies the associated CDR type. The content of these CDR types is specified in clause 6.

Table 5.2.3.1.1: Record type overview for combined MMS R/S

Record trigger	C1	C2	C3	C4	C5	C6	C7	C8	C9	C10	Any time between C1 .. C8
Record type	O1S	R1NRq	R1NRs	R1Rt	R1A	O1D	R1RR	O1R	R1C	RMD	OMD

5.2.3.2 Distributed Originator and Recipient MMSR/S case

The chargeable events for the case of distributed Originator and Recipient MMS R/Ss are depicted in figures 5.1.2.2/3 and further listed in table 5.1.2.1. Due to the fact that only event based charging applies to MMS (see clause 5.2.1), these chargeable events translate 1:1 into the CDR types listed in tables 5.2.3.2.1/2 below.

The first row in the tables refers to the trigger labels in figure/table 5.1.2. The second row identifies the associated CDR type. The content of these CDR types is specified in clause 6.

Table 5.2.3.2.1: Record type overview for the Originator MMS R/S

Record trigger	O1	O2	O3	O4	O5	O6	O7	Any time between O1.. O7
Record type	O1S	O4FRq	O4FRs	O4D	O1D	O4R	O1R	OMD

Table 5.2.3.2.2: Record type overview for the Recipient MMS R/S

Record trigger	R1	R2	R3	R4	R5	R6	R7	R8	R9	R10	R11	R12	Anytime after R2
Record type	R4F	R1NRq	R1NRs	R1Rt	R1A	R4DRq	R4DRs	R1RR	R4RRq	R4RRs	R1C	RMD	RMD

5.2.3.3 MMBox related CDRs

The chargeable events for the MMBox management are depicted in figure 5.1.3.1 and further listed in table 5.1.3.2. Due to the fact that only event based charging applies to MMS (see clause 5.2.1), these chargeable events translate 1:1 into the CDR types listed in table 5.2.3.3.1 below.

The first row in table 5.2.3.3.1 refers to the trigger labels in figure/table 5.1.3.1.

The second row identifies the associated CDR type. The content of these CDR types is specified in clause 6.

Table 5.2.3.3.1 : Trigger type overview for MMBox management

Record trigger	M1	M2	M3	M4
Record type	Bx1U	Bx1S	Bx1V	Bx1D

5.2.3.4 CDRs related to VASP transactions

The chargeable events for the VASP transactions are depicted in figure 5.1.4.1 and further listed in table 5.1.4.2. Due to the fact that only event based charging applies to MMS (see clause 5.2.1), these chargeable events translate 1:1 into the CDR types listed in table 5.2.3.4.1 below.

The first row in table 5.2.3.4.1 refers to the trigger labels in figure/table 5.1.4.1.

The second row identifies the associated CDR type. The content of these CDR types is specified in clause 6.

Table 5.2.3.4.1: Record type overview for VASP transactions

Record trigger	V1	V2	V3	V4	V5	V6	V7	V8	V9	V10	V11
Record type	MM7S	MM7DRq	MM7DRs	MM7C	MM7R	MM7DRRq	MM7DRRs	MM7RRq	MM7RRs	MM7ER	MM7EC

5.2.4 Ga record transfer flows

Not applicable, as the separation of the CDF and CGF is not in the scope of the MMS charging standards. Refer to clause 4.2 for further information.

NOTE: Vendors may nevertheless implement a separate CDF and CGF for MMS charging. In this case, it is recommended that the approach chosen conforms to the principles and protocol applications specified in TS 32.295 [54].

5.2.5 Bm CDR file transfer

The integrated CGF of the MMS R/S transfers the CDR files to the BD as described in TS 32.297 [52].

In MMS, both fully qualified partial CDRs (FQPC) and reduced partial CDRs (RPC), as specified in TS 32.240 [1] may be supported on the Bm interface. In line with TS 32.240 [1], the support of FQPCs is mandatory, the support of RPCs is optional. For further details on the Bm protocol application refer to TS 32.297 [52].

5.3 MMS online charging scenarios

MMS online charging uses the Credit Control (CC) application as specified in TS 32.299 [50].

5.3.1 Basic principles

MMS charging may use the Immediate Event Charging (IEC) principle or the Event Charging with Unit Reservation (ECUR) principle as specified in TS 32.299 [50]. The chargeable events for subscriber charging are associated with MM submission and MM retrieval.

An implementation shall use only one principle for all chargeable events throughout a given instance of providing MMS service to the user, i.e. either IEC or ECUR.

The units used for quota shall be service specific and based on an MM.

5.3.2 Ro message flows

5.3.2.0 General

The message flows described in the present document specify the charging communications between MMS R/S and the Online Charging System (OCS) for different charging scenarios. The MMS messages associated with these charging

scenarios are shown primarily for general information and to illustrate the charging triggers that are also used for MMS offline charging.

5.3.2.1 MM submission

Figure 5.3.2.1.1 shows the Credit-Control transactions that are required between MMS R/S and OCS during the MM submission. In this scenario the originator MMS User Agent is the party to charge for the MM submission.

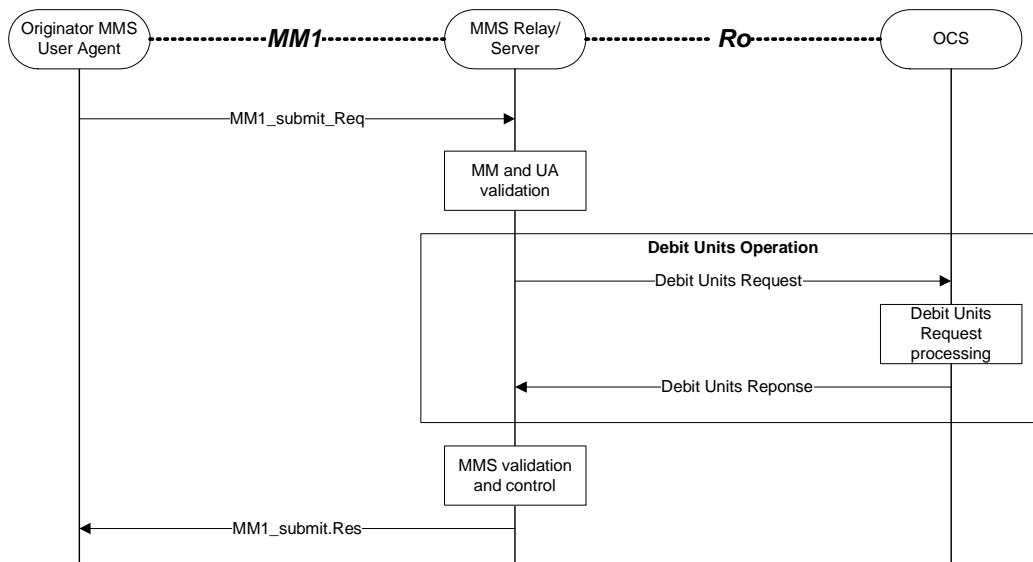
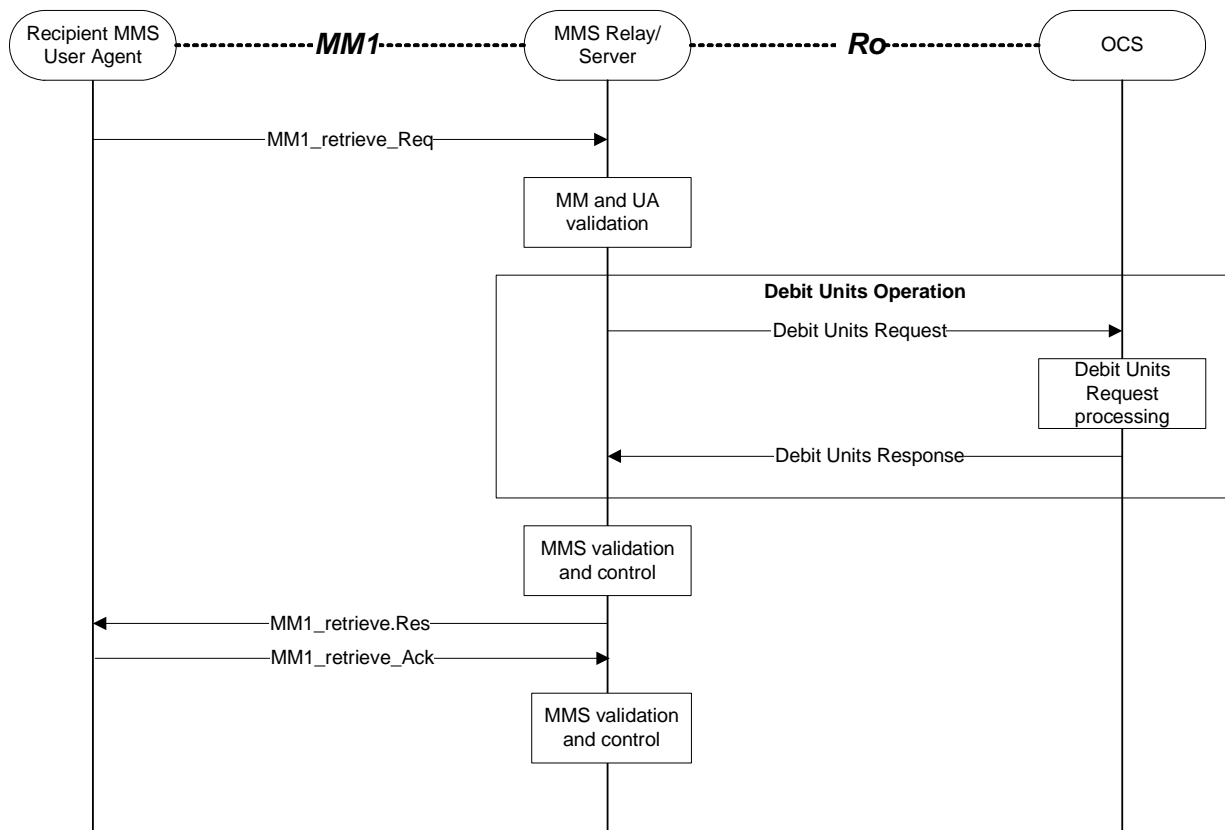

Figure 5.3.2.1.1: MMS online charging scenario for MM submission

5.3.2.2 MM retrieval

Figures 5.3.2.2.1 and 5.3.2.2.2 show the Credit-Control transactions that are required between MMS R/S and OCS during the MM retrieval. In this scenario the Recipient MMS User Agent is the party to charge for the reception.



NOTE: For IEC, if the retrieval process is not successful for any reason (e.g. MM1_retrieve_Ack is not received) and another MM1_retrieve_req is received for the same message (identified by the Message ID), it is OCS logic to determine whether the subsequent requests are charged.

Figure 5.3.2.2.1 : MMS online charging for MM retrieval using IEC

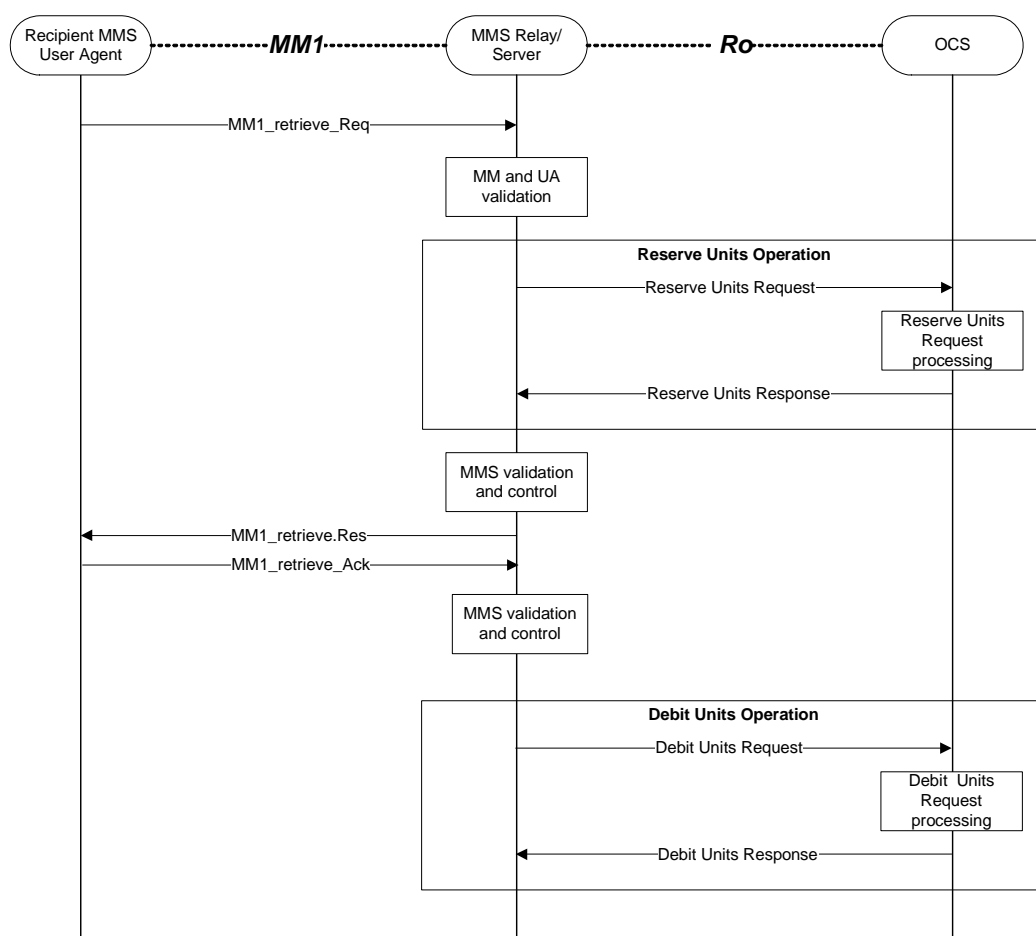

Figure 5.3.2.2.2: MMS online charging scenario for MM retrieval using ECUR

5.3.2.3 MMS reports

5.3.2.3.1 Delivery report

Editor's note: The completion of this clause is ffs.

5.3.2.3.2 Read report

Editor's note: The completion of this clause is ffs.

5.4 MMS converged online and offline charging scenarios

5.4.1 Basic principles

5.4.1.1 General

Converged charging may be performed by the MMS Node interacting with CHF using Nchf specified in TS 32.290 [2] and TS 32.291 [3]. In order to provide the data required for the management activities outlined in TS 32.240 [1] (Credit-

Control, accounting, billing, statistics etc.), the MMS Node shall be able to perform converged charging for each of the MMS transactions.

The MMS Node shall be able to perform convergent charging by interacting with CHF, for charging data related to MMS. The Charging Data Request and Charging Data Response are exchanged between the MMS Node and the CHF, based on PEC, IEC or ECUR scenarios specified in TS 32.290 [2]. The Charging Data Request is issued by the MMS Node towards the CHF when certain conditions (chargeable events) are met.

The contents and purpose of each charging event that triggers interaction with CHF, as well as the chargeable events that trigger them, are described in the following sub-clauses.

A detailed formal description of the converged charging parameters defined in the present document is to be found in TS 32.291 [3].

A detailed formal description of the CDR parameters defined in the present document is to be found in TS 32.298 [51].

The chargeable events or messages exchanged between the MMS Node and the other nodes are described with generic names (i.e., MMS submit, MMS retrieve), to reflect MMS sending or retrieval by/from the MMS Node, independently from the protocol conveying the MMS.

5.4.1.2 Applicable Triggers in the MMS Node

5.4.1.2.1 General

When a charging event is issued towards the CHF, it includes details such as Subscriber identifier (e.g., SUPI).

Each trigger condition (i.e., chargeable event) defined for the MMS converged charging functionality, is specified with the associated behaviour when they are met.

When an MMS IS sent or retrieved, and the converged charging is activated, the MMS Node a Charging Data Request [Initial] towards the CHF to get authorization to start in ECUR mode. In IEC mode, the Charging Data Request [Event] is sent towards the CHF.

Table 5.4.1.2.1 summarizes the set of default trigger conditions and their category which shall be supported by the MMS Node. For "immediate report" category, the table also provides the corresponding Charging Data Request [Initial, Event, Termination] message sent from MMS Node towards the CHF.

Table 5.4.1.2.1: Default Trigger conditions in MMS Node

Trigger Conditions	Trigger level	Default category	CHF allowed to change category	CHF allowed to enable and disable	Message when "immediate reporting" category
MMS Submit request	-	Immediate	Not Applicable	Not Applicable	IEC: Charging Data Request [Event]
MMS Retrieve request	-	Immediate	Not Applicable	Not Applicable	IEC: Charging Data Request [Event] ECUR: Charging Data Request [Initial]
MMS Retrieve acknowledge	-	Immediate	Not Applicable	Not Applicable	PEC: Charging Data Request [Event] ECUR: Charging Data Request [Termination]

For converged charging, the following details of chargeable events and corresponding actions in the MMS Node are defined in Table 5.4.1.2.2:

Table 5.4.1.2.2: Chargeable events and their related actions in MMS Node

Chargeable event	Conditions	MMS Node action
MMS Submit request		IEC: Charging Data Request [Event]
MMS Retrieve request		IEC: Charging Data Request [Event] ECUR: Charging Data Request [Initial] with a possible request quota for later use
MMS Retrieve acknowledge		PEC: Charging Data Request [Event] ECUR: Charging Data Request [Termination], indicating that charging session is terminated

The CDR generation mechanism processed by the CHF upon receiving Charging Data Request [Event, Initial, Termination] issued by the MMS Node for these chargeable events, is specified in clause 5.4.3.

5.4.1.3 CHF selection

The CHF to be used by the MMS Node can be:

- Discovered via NRF.
- Locally provisioned.

The option depends on Operator's policies.

When CHF selection by MMS Node is performed via NRF based discovery, the CHF can be discovered based on the UE identifier.

5.4.2 Message flows

5.4.2.1 Introduction

The different scenarios below focus on the different messages from/to the MMS Node and corresponding interaction with the CHF, based on scenarios specified in clause 5.3.2.

5.4.2.2 MM submission

Figure 5.4.2.2.1 describes the scenario where an MMS is submitted to the MMS Node for IEC mode

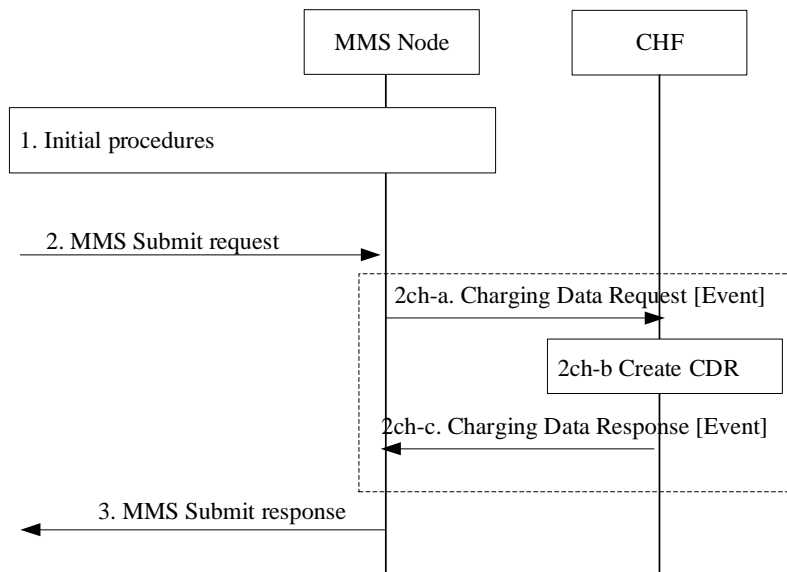

Figure 5.4.2.2.1: MMS submission to MMS Node for IEC

- 1. Initial procedures: see applicable flows.
- 2. The MMS Node receives "MMS Submit request" message from an originator MMS user agent.
- 2ch-a. The MMS Node sends Charging Data Request [Event] to CHF for the MMS submission.
- 2ch-b. The CHF creates a CDR for this MMS submission.
- 2ch-c. The CHF acknowledges by sending Charging Data Response [Event] to the MMS Node.
- 3. The MMS Node returns "MMS Submit response" with appropriate result.

The table 5.4.2.2.1 describes the correspondence between the message in this scenario, and the message in the different Network scenario for which it is applicable.

Table 5.4.2.2.1: Messages mapping

Message	Message in Network scenario	Reference
2. MMS Submit request	MM1_submit_Req	MMS [401]
3. MMS Submit response	MM1_submit_Res	MMS [401]

5.4.2.3 MM retrieval

Figure 5.4.2.3.1 describes the scenario where an MMS is retrieved from the MMS Node for IEC mode

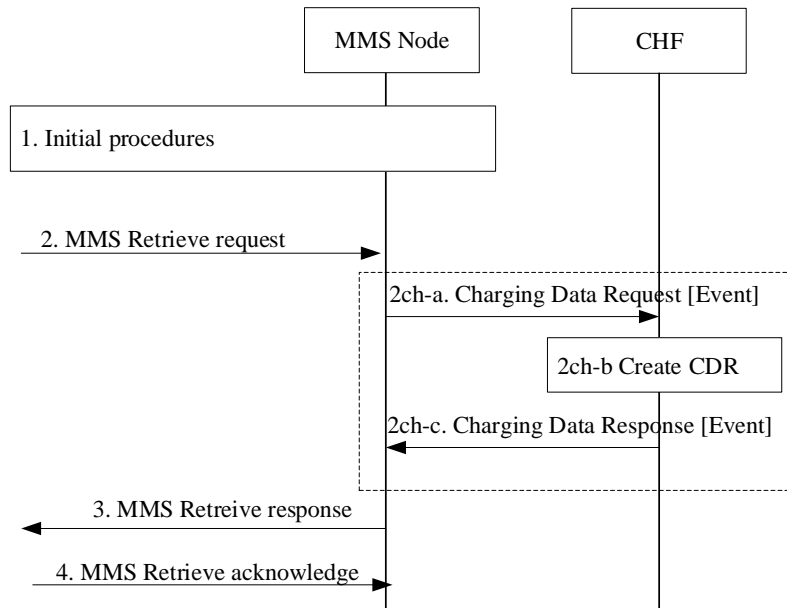

Figure 5.4.2.3.1 MMS retrieval from MMS Node for IEC

1. Initial procedures: see applicable flows.
2. The MMS Node receives "MMS Retrieve request" message from a recipient MMS user agent
- 2ch-a. The MMS Node sends Charging Data Request [Event] to CHF for the MMS submission.
- 2ch-b. The CHF creates a CDR for this MMS retrieval.
- 2ch-c. The CHF acknowledges by sending Charging Data Response [Event] to the MMS Node.
3. The MMS Node returns "MMS Retrieve response" with appropriate result.
4. The MMS Node receives "MMS Retrieve acknowledge" with the result.

Figure 5.4.2.3.2 describes the scenario where an MMS is retrieved from the MMS Node for ECUR mode.

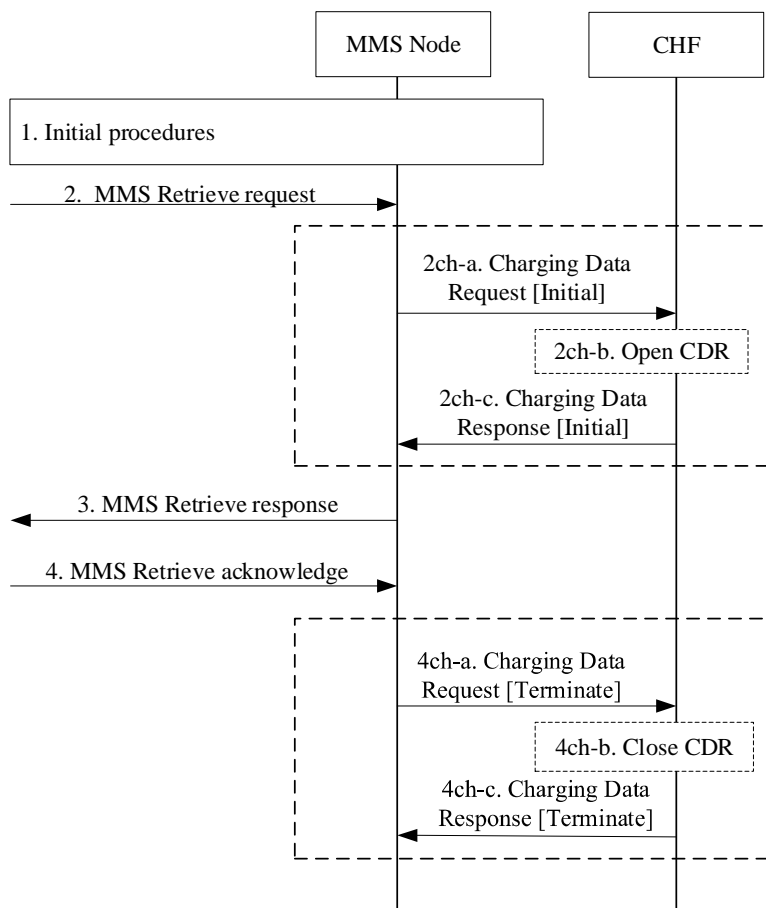

Figure 5.4.2.3.2: MMS retrieval from MMS Node for ECUR

1. Initial procedures: see applicable flows.
2. The MMS Node receives "MMS Retrieve request" message from a recipient MMS user agent.
 - 2ch-a. The MMS Node sends Charging Data Request [Initial] to CHF for authorization.
 - 2ch-b. The CHF opens CDR for this MMS retrieval.
 - 2ch-c. The CHF acknowledges by sending Charging Data Response [Initial] to the MMS Node
3. The MMS Node returns "MMS Retrieve response" with appropriate result.
4. The MMS Node receives "MMS Retrieve acknowledge" with the result.
 - 4ch-a. The MMS Node sends Charging Data Request [Termination] to the CHF for terminating the charging associated with MMS retrieval.
 - 4ch-b. The CHF closes the CDR for this MMS retrieval.
 - 4ch-c. The CHF acknowledges by sending Charging Data Response [Termination] to the MMS Node.

Figure 5.4.2.3.3 describes the scenario where an MMS is retrieved from the MMS Node for PEC mode7

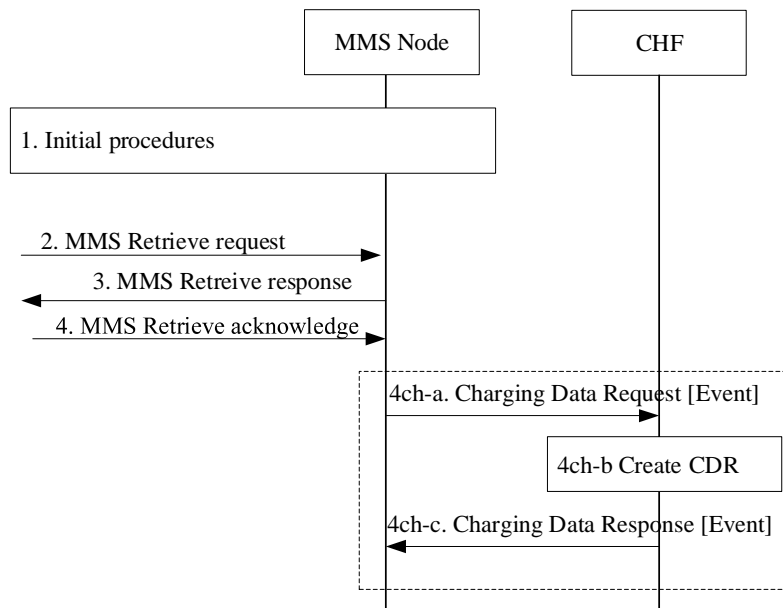

Figure 5.4.2.3.3 MMS retrieval from MMS Node for PEC

1. Initial procedures: see applicable flows.
2. The MMS Node receives "MMS Retrieve request" message from a recipient MMS user agent
3. The MMS Node returns "MMS Retrieve response" with appropriate result.
4. The MMS Node receives "MMS Retrieve acknowledge" with the result.
- 4ch-a. The MMS Node sends Charging Data Request [Event] to CHF for the MMS submission.
- 4ch-b. The CHF creates a CDR for this MMS retrieval.
- 4ch-c. The CHF acknowledges by sending Charging Data Response [Event] to the MMS Node.

The table 5.4.2.3.1 describes the correspondence between the message in all scenarios, and the message in the different Network scenario for which it is applicable.

Table 5.4.2.3.1: Messages mapping

Message	Message in Network scenario	Reference
2. MMS Retrieve request	MM1_retrieve_Req	MMS [401]
3. MMS Retrieve response	MM1_retrieve_Res	MMS [401]
4. MMS Retrieve acknowledge	MM1_retrieve_Ack	MMS [401]

5.4.3 CDR generation

5.4.3.1 Introduction

The CHF CDRs for MMS charging are generated by the CHF to collect charging information.

The following clauses describe in detail the conditions for generating, opening and closing the CHF CDR, which shall be supported by the CHF.

5.4.3.2 Triggers for CHF CDR

5.4.3.2.1 General

A MMS charging CHF CDR is used to collect charging information related to MMS chargeable events for PEC, IEC and ECUR.

5.4.3.2.2 Triggers for CHF CDR generation

A CHF CDR is generated by the CHF for each received Charging Data Request [Event].

5.4.3.2.3 Triggers for CHF CDR opening

A CHF CDR shall be opened when the CHF receives Charging Data Request [Initial].

5.4.3.2.4 Triggers for CHF CDR closure

The CHF CDR shall be closed when the CHF receives Charging Data Request [Termination].

5.4.4 Ga record transfer flows

Details of the Ga protocol application are specified in TS 32.295 [54].

5.4.5 Bm CDR file transfer

Details of the Bm protocol application are specified in TS 32.297 [52].

6 Definition of charging information

6.0 General

This clause provides the Stage 3 specifications of the CDR type and content for MMS, in line with the CDR type definitions provided in clause 5.2.3.

6.1 Data description for MMS offline charging

6.1.0 Introduction

Dedicated types of CDRs can be generated for MMS by the MMS R/Ss. The content of each CDR type is defined in one of the tables that are part of this clause. For each CDR type the parameter definition includes the parameter name, description and category.

The MMS R/S CGF shall be able to provide the CDRs at the Billing System (BS) interface in the format and encoding described in the present document. In MMS, both fully qualified partial CDRs (FQPC) and reduced partial CDRs (RPC), as specified in TS 32.240 [1] may be supported on the Bm interface. In line with TS 32.240 [1], the support of FQPCs is mandatory, the support of RPCs is optional.

The following tables provide a brief description of each CDR parameter and the category in the tables are used according to the charging data configuration defined in clause 5.4 of TS 32.240 [1]. Full definitions of the parameters, sorted by the parameter name in alphabetical order, are provided in TS 32.298 [51].

6.1.1 MMS records for Originator MMS R/S

6.1.1.0 General

The following subclauses specify CDRs created in the OOriginator MMS R/S based on messages flowing over the MM1 and MM4 reference points. The CDRs referring to MM4 messages (Originator MM4 *** CDR) are created only if the Originator and Recipient MMS R/Ss communicate over the MM4 interface (i.e. the OOriginator MMS R/S is not also the Recipient MMS R/S). The CDRs referring to MM1 messages (Originator MM1 *** CDR) are created regardless of whether the OriginatorOriginator MMS R/S is also the Recipient MMS R/S or not. Unless otherwise specified, the CDR parameters are copied from the corresponding MM1 or MM4 message parameters as applicable.

6.1.1.1 Originator MM1 Submission record (O1S-CDR)

If enabled, an Originator MM1 Submission O1S-CDR shall be produced in the Originator MMS R/S for each MM submitted in an MM1_submit.REQ by an originator MMS User Agent to the Originator MMS R/S if and when the Originator MMS R/S responds with an MM1_submit.RES. The operator can configure whether this CDR, if enabled, shall only be created for MM1_submit.RES indicating acceptance of the submitted MM, or also for the unsuccessful submissions.

NOTE 1: This includes the case where the MM is a reply-MM to an original MM. In this case the MMS User Agent sending the reply-MM is called the originator MMS User Agent of this reply-MM and the MMS R/S receiving the reply-MM in an MM1_submit.REQ is called the OriginatorOriginator MMS R/S for this reply-MM.

NOTE 2: The case of an MMS R/S receiving an MM1_forward.REQ is treated in clause 6.1.3.

Table 6.1.1.1.1: Originator MM1 Submission record (O1S-CDR)

Field	Category	Description
Record Type	M	Originator MM1 Submission record
Originator MMS Relay/Server Address	M	.IP address or domain name of OriginatorOriginator MMS R/S
Message ID	M	The MM identification provided by the OriginatorOriginator MMS R/S
Reply-Charging ID	C	This field is present in the CDR only if the MM is a reply-MM to an original MM. The Reply-Charging ID is the Message ID of the original MM
Originator address	M	The address of the originator MMS User Agent (i.e., of the MMS User Agent that has sent the MM1_submit.REQ)
Recipients address list	M	The address(es) of the Recipient MMS User Agent(s) of the MM. Multiple addresses are possible if the MM is not a reply MM
Access Correlation	Om	A unique identifier delivered by the used access network domain of the originator MMS User Agent
Content type	M	The content type of the MM content
Content Class	Oc	This field classifies the content of the MM to the smallest content class to which the MM belongs, if specified in the MM1_submit_REQ
DRM Content	Oc	This field indicates if the MM contains DRM-protected content, if specified in the MM1_submit_REQ
Adaptations	Oc	This field indicates if the originator allows adaptation of the content (default True), if specified in the MM1_submit_REQ
MM component list	Om	The list of media components with volume size
Message size	M	The total size of the MM content
Message class	Oc	The class selection such as personal, advertisement, information service if specified in the MM1_submit_REQ
Charge Information	Om	The charged party indication and charge type
Submission Time	Oc	The time at which the MM was submitted from the originator MMS User Agent if specified in the MM1_submit_REQ
Time of Expiry	Oc	The desired date of expiry or duration of time prior to expiry for the MM if specified by the originator MMS User Agent
Earliest Time Of Delivery	C	This field contains either the earliest time to deliver the MM or the number of seconds to wait before delivering the MM as specified by the originator MMS User Agent
Duration Of Transmission	Om	The time used for transmission of the MM between the User Agent and the MMS R/S
Request Status Code	Om	The status code of the MM as received in the MM1_submit_REQ
Delivery Report Requested	Om	This field indicates whether a delivery report has been requested by the originator MMS User Agent or not
Reply Charging	Oc	A request for reply-charging if specified by the originator MMS User Agent
Reply Deadline	Oc	In case of reply-charging the latest time of submission of replies granted to the recipient(s) as specified by the originator MMS User Agent
Reply Charging Size	Oc	In case of reply-charging the maximum size for reply-MM(s) granted to the recipient(s) as specified by the originator MMS User Agent
Priority	Oc	The priority (importance) of the message if specified by the originator MMS User Agent
Sender visibility	Om	A request to show or hide the sender's identity when the message is delivered to the recipient as specified by the originator MMS User Agent
Read reply requested	Om	A request for read-reply report as specified in the MM1_submit.REQ
Status Text	Oc	This field includes a more detailed technical status of the message at the point in time when the CDR is generated. This field is only present if the MM submission is rejected
Applic-ID	Oc	If present, this field holds the identification of the destination application that the underlying MMS abstract message was addressed to.
Reply-Applic-ID	Oc	If present, this parameter indicates a "reply path", i.e. the identifier of the application to which delivery reports, read-reply reports and reply-MMs are addressed.
Aux-Applic-Info	Oc	If present, this parameter indicates additional application/implementation specific control information.
Record Time Stamp	Om	Time of generation of the CDR
Local Record Sequence Number	Om	Consecutive record number created by this node. The number is allocated sequentially including all CDR types
MMBox Storage Information	Oc	A set of parameters related to the MMBox management. This parameter is only present if the MMBox feature is supported by the MMS R/S and storage of the MM was requested by originator MMS User Agent (i.e., of the MMS User Agent that has sent the MM1_submit.REQ)
MSCF Information	Oc	A set of parameters provided by the MSCF when interacting with the MMS R/S via the MM10 interface prior to the MM1_submit.RES

Field	Category	Description
Serving network identity	Oc	If present this parameter holds the SGSN PLMN Identifier (MCC and MNC) used during this record
RAT Type	Oc	The radio access technology used during this record.
MS Time Zone	Oc	This field contains the MS Time Zone the MMS User Agent is currently located, if available.
Record extensions	Oc	A set of network/manufacture specific extensions to the record. Conditioned upon the existence of an extension

6.1.1.2 Originator MM4 Forward Request record (O4FRq-CDR)

If enabled, an Originator MM4 Forward Request O4FRq-CDR shall be produced in the Originator MMS R/S if and when the Originator MMS R/S has sent an MM4_forward.REQ to the Recipient MMS R/S, regardless of whether or not an MM4_forward.RES is received from the recipient. That is, the CDR is created upon completion of transmission of the MM4_forward.REQ.

The MM4_forward.REQ may be generated as a reaction to an incoming MM1_forward.REQ. In this case, the *Originator address* field specifies the address of the originator MMS User Agent of the original MM, whereas the address of the forwarding MMS User Agent is contained in the *Forwarding address* field.

Table 6.1.1.2.1: Originator MM4 Forward Request record (O4FRq-CDR)

Field	Category	Description
Record Type	M	Originator MM4 Forward Request record
Originator MMS Relay/Server Address	M	IP address or domain name of the Originator MMS R/S
Recipient MMS Relay/Server Address	M	IP address or domain name of the Recipient MMS R/S
Message ID	M	The MM identification provided by the Originator MMS R/S
3GPP MMS Version	O _M	The MMS version of the Originator MMS R/S
Originator address	M	The address of the originator MMS User Agent of the MM. (If the MM4_forward.REQ is generated as a reaction to an incoming MM1_forward.REQ, this is the address of the originator MMS User Agent of the original MM)
Recipients address list	M	The address(es) of the Recipient MMS User Agent(s) of the MM as specified in the MM4_forward.REQ that triggered the CDR
Recipient address for routing	M	The address(es) of the Recipient MMS User Agent(s) of the MM for that routing is requested as specified in the MM4_forward.REQ that triggered the CDR
Content type	M	The content type of the MM content
Content Class	O _c	This field classifies the content of the MM to the smallest content class to which the MM belongs, if specified in the MM4_forward_REQ
DRM Content	O _c	This field indicates if the MM contains DRM-protected content, if specified in the MM4_forward_REQ
Adaptations	O _c	This field indicates if the originator allows adaptation of the content (default True), if specified in the MM4_forward_REQ
MM component list	O _M	The list of media components with volume size
Message size	M	The total size of the MM content
Message class	C	The class of the MM (e.g., personal, advertisement, information service) if specified by the Originator MMS User Agent
Submission Time	M	The time at which the MM was submitted or forwarded as specified in the corresponding MM1_submit.REQ or MM1_forwarding.REQ
Time of Expiry	C	The desired date of expiry or duration of time prior to expiry for the MM if specified by the originatorOriginator MMS User Agent
Delivery Report Requested	M	This field indicates whether a delivery report has been requested by the originator MMS User Agent or not
Priority	C	The priority (importance) of the message if specified by the originator MMS User Agent
Sender visibility	M	A request to show or hide the sender's identity when the message is delivered to the MM recipient if the Originator MMS User Agent has requested her address to be hidden from the recipient
Read reply requested	M	A request for read-reply report if the originator MMS User Agent has requested a read-reply report for the MM
Acknowledgement Request	M	Request for MM4_forward.RES
Forward counter	C	A counter indicating the number of times the particular MM was forwarded
Forwarding address	C	The address(es) of the forwarding MMS User Agent(s). Multiple addresses are possible. In the multiple address case this is a sequential list of the address(es) of the forwarding MMS User Agents who forwarded the same MM
Applic-ID	O _c	If present, this field holds the identification of the destination application that the underlying MMS abstract message was addressed to.
Reply-Applic-ID	O _c	If present, this parameter indicates a "reply path", i.e. the identifier of the application to which delivery reports, read-reply reports and reply-MMs are addressed.
Aux-Applic-Info	O _c	If present, this parameter indicates additional application/implementation specific control information.
Record Time Stamp	M	Time of generation of the CDR
Local Record Sequence Number	O _M	Consecutive record number created by this node. The number is allocated sequentially including all CDR types
Serving network identity	O _M	SGSN PLMN Identifier (MCC and MNC) used during this record
Record extensions	O _c	A set of network/manufacture specific extensions to the record. Conditioned upon the existence of an extension

6.1.1.3 Originator MM4 Forward Response record (O4FRs-CDR)

If enabled, an Originator MM4 Forward Response O4FRs-CDR shall be produced in the Originator MMS R/S if and when, after an MM has been forwarded with an MM4_forward.REQ to the Recipient MMS R/S, the Originator MMS R/S receives a corresponding MM4_forward.RES from the Recipient MMS R/S.

Table 6.1.1.3.1: Originator MM4 Forward Response record (O4FRs-CDR)

Field	Category	Description
Record Type	M	Originator MM4 Forward Response record
Originator MMS Relay/Server Address	O _M	IP address or domain name of the Originator MMS R/S
Recipient MMS Relay/Server Address	M	IP address or domain name of the Recipient MMS R/S
Message ID	M	The MM identification provided by the Originator MMS R/S
3GPP MMS Version	O _M	The MMS version of the Recipient MMS R/S
Request Status Code	O _M	The status code of the request to route forward the MM as received in the MM4_forward.RES
Status Text	O _C	This field includes the status text as received in the MM4_forward.RES corresponding to the Request Status Code. Present only if provided in the MM4_forward.RES
Record Time Stamp	O _M	Time of generation of the CDR
Local Record Sequence Number	O _M	Consecutive record number created by this node. The number is allocated sequentially including all CDR types
Record extensions	O _C	A set of network/manufacture specific extensions to the record. Conditioned upon the existence of an extension

6.1.1.4 Originator MM4 Delivery Report record (O4D-CDR)

If enabled, an Originator MM4 Delivery Report O4D-CDR shall be produced in the Originator MMS R/S if and when the Originator MMS R/S receives an MM4_delivery_report.REQ from the Recipient MMS R/S.

Table 6.1.1.4.1: Originator MM4 Delivery Report record (O4D-CDR)

Field	Category	Description
Record Type	M	Originator MM4 Delivery report record
Recipient MMS Relay/Server Address	O _M	IP address or domain name of the Recipient MMS R/S
Originator MMS Relay/Server Address	O _M	IP address or domain name of the Originator MMS R/S
Message ID	M	The MM identification provided by the Originator MMS R/S
3GPP MMS Version	O _M	The MMS version of the Recipient MMS R/S
Originator address	O _M	The address of the originator MMS User Agent of the MM
Recipient address	M	The address of the MM recipient of the MM
MM Date and time	M	Date and time the MM was handled (retrieved, expired, rejected, etc.) as specified in the MM4_delivery_report
Acknowledgement Request	M	Request for MM4_delivery_report.RES
MM Status Code	M	The status code of the delivered MM as received in the MM4_delivery_report.REQ
Status Text	O _C	This field includes the status text as received in the MM4_delivery_report.REQ corresponding to the MM Status Code. Present only if provided in the MM4_delivery_report.REQ
Applic-ID	O _C	If present, this field holds the identification of the destination application that the underlying MMS abstract message was addressed to.
Reply-Applic-ID	O _C	If present, this parameter indicates a "reply path", i.e. the identifier of the application to which delivery reports, read-reply reports and reply-MMSs are addressed.
Aux-Applic-Info	O _C	If present, this parameter indicates additional application/implementation specific control information.
Record Time Stamp	O _M	Time of generation of the CDR
Local Record Sequence Number	O _M	Consecutive record number created by this node. The number is allocated sequentially including all CDR types
Record extensions	O _C	A set of network/manufacture specific extensions to the record. Conditioned upon the existence of an extension

6.1.1.5 Originator MM1 Delivery Report record (O1D-CDR)

If enabled, an Originator MM1 Delivery Report O1D-CDR shall be produced in the Originator MMS R/S if and when the Originator MMS R/S sends an MM1_delivery_report.REQ to the originator MMS User Agent.

Table 6.1.1.5.1: Originator MM1 Delivery Report record (O1D-CDR)

Field	Category	Description
Record Type	M	Originator MM1 Delivery report record
Recipient MMS Relay/Server Address	O _M	IP address or domain name of the Recipient MMS R/S
Originator MMS Relay/Server Address	O _M	IP address or domain name of the Originator MMS R/S
Access Correlation	O _M	A unique identifier delivered by the used access network domain of the originator MMS User Agent
Message ID	M	The MM identification provided by the Originator MMS R/S
3GPP MMS Version	O _M	The MMS version of the Originator MMS R/S
Originator address	O _M	The address of the originator MMS User Agent of the MM
Recipient address	M	The address of the MM recipient of the MM
MM Status Code	O _M	The status code of the MM as sent in the MM Status information element in the MM1_delivery_report.REQ
Applic-ID	O _C	If present, this field holds the identification of the destination application that the underlying MMS abstract message was addressed to.
Reply-Applic-ID	O _C	If present, this parameter indicates a "reply path", i.e. the identifier of the application to which delivery reports, read-reply reports and reply-MMs are addressed.
Aux-Applic-Info	O _C	If present, this parameter indicates additional application/implementation specific control information.
Record Time Stamp	O _M	Time of generation of the CDR
Local Record Sequence Number	O _M	Consecutive record number created by this node. The number is allocated sequentially including all CDR types
Serving network identity	O _C	If present this parameter holds the SGSN PLMN Identifier (MCC and MNC) used during this record
RAT Type	O _C	The radio access technology used during this record.
MS Time Zone	O _C	This field contains the MS Time Zone the MMS User Agent is currently located, if available.
Record extensions	O _C	A set of network/manufacture specific extensions to the record. Conditioned upon the existence of an extension

6.1.1.6 Originator MM4 Read Reply Report record (O4R-CDR)

If enabled, an Originator MM4 Read Reply Report O4R-CDR shall be produced in the Originator MMS R/S if and when the Originator MMS R/S receives an MM4_read_reply_report.REQ from the Recipient MMS R/S.

Table 6.1.1.6.1: Originator MM4 Read Reply Report record (O4R-CDR)

Field	Category	Description
Record Type	M	Originator MM4 Read reply report record
Recipient MMS Relay/Server Address	O _M	IP address or domain name of the Recipient MMS R/S
Originator MMS Relay/Server Address	O _M	IP address or domain name of the Originator MMS R/S
Message ID	M	The MM identification provided by the Originator MMS R/S
3GPP MMS Version	O _M	The MMS version of the Recipient MMS R/S
Originator address	O _M	The address of the originator MMS User Agent of the MM
Recipient address	O _M	The address of the MM recipient of the MM
MM Date and time	O _M	Date and time the MM was handled (retrieved, expired, rejected, etc.)
Acknowledgement Request	M	Request for MM4_read_reply_report.RES
Read Status	O _M	The status of the MM as received in the MM4_read_reply_report.REQ
Status Text	O _C	This field includes the status text if received in the MM4_read_reply_report.REQ corresponding to the Read Status. Present only if provided in the MM4_read_reply_report.REQ
Applic-ID	O _C	If present, this field holds the identification of the destination application that the underlying MMS abstract message was addressed to.
Reply-Applic-ID	O _C	If present, this parameter indicates a "reply path", i.e. the identifier of the application to which delivery reports, read-reply reports and reply-MMs are addressed.
Aux-Applic-Info	O _C	If present, this parameter indicates additional application/implementation specific control information.
Record Time Stamp	O _M	Time of generation of the CDR
Local Record Sequence Number	O _M	Consecutive record number created by this node. The number is allocated sequentially including all CDR types
Record extensions	O _C	A set of network/manufacture specific extensions to the record. Conditioned upon the existence of an extension

6.1.1.7 Originator MM1 Read Reply Originator record (O1R-CDR)

If enabled, an Originator MM1 ReadReply Originator O1R-CDR shall be produced in the Originator MMS R/S if and when the Originator MMS R/S sends an MM1_read_reply_Originator.REQ to the originator MMS User Agent.

Table 6.1.1.7.1: Originator MM1 Read Reply Originator record (O1R-CDR)

Field	Category	Description
Record Type	M	Originator MM1 Read reply Originator record
Recipient MMS Relay/Server Address	O _M	IP address or domain name of the Recipient MMS R/S
Originator MMS Relay/Server Address	O _M	IP address or domain name of the Originator MMS R/S
Access Correlation	O _M	A unique identifier delivered by the used access network domain of the originator MMS User Agent.
Message ID	M	The MM identification provided by the Originator MMS R/S
3GPP MMS Version	O _M	The MMS version of the Originator MMS R/S
Originator address	O _M	The address of the originator MMS User Agent of the MM
Recipient address	O _M	The address of the MM recipient of the MM
Read Status	O _M	The status of the MM as sent in the MM1_read_reply Originator.REQ
Applic-ID	O _C	If present, this field holds the identification of the destination application that the underlying MMS abstract message was addressed to.
Reply-Applic-ID	O _C	If present, this parameter indicates a "reply path", i.e. the identifier of the application to which delivery reports, read-reply reports and reply-MMs are addressed.
Aux-Applic-Info	O _C	If present, this parameter indicates additional application/implementation specific control information.
Record Time Stamp	O _M	Time of generation of the CDR
Local Record Sequence Number	O _M	Consecutive record number created by this node. The number is allocated sequentially including all CDR types
Serving network identity	O _C	If present this parameter holds the SGSN PLMN Identifier (MCC and MNC) used during this record
RAT Type	O _C	The radio access technology used during this record.
MS Time Zone	O _C	This field contains the MS Time Zone the MMS User Agent is currently located, if available.
Record extensions	O _C	A set of network/manufacture specific extensions to the record. Conditioned upon the existence of an extension

6.1.1.8 Originator MM Deletion record (OMD-CDR)

If enabled, an Originator MM Deletion OMD-CDR shall be produced in the Originator MMS R/S, after sending an MM1_submit.RES to the originator MMS User Agent, if and when:

- a) the Originator MMS R/S decides to abandon processing of the MM at any point after receiving the corresponding MM1_submit.REQ; or
- b) the Originator MMS R/S decides to delete the MM because of expiry of storage time, which may either be indicated in the submit request or governed by operator procedure (e.g. after successful MM delivery).

Abandoning the processing of the MM, or deleting the MM, implies that there remains no knowledge of the MM in the Originator MMS R/S.

The status code indicates the precise reason for abandoning or deleting the MM with respect to the MMS transactions specified in TS 23.140 [201].

This CDR is created regardless of whether the Originator MMS R/S is also the Recipient MMS R/S or not.

Table 6.1.1.8.1: Originator MM Deletion record (OMD-CDR)

Field	Category	Description
Record Type	M	Originator MM Deletion record
Originator MMS R/S Address	O _M	IP address or domain name of the Originator MMS R/S
Recipient MMS R/S Address	C	IP address or domain name of the Recipient MMS R/S. This field is present, if such an address is known
Message ID	M	The MM identification provided by the Originator MMS R/S
Message size	O _M	The total size of the MM content
MM Status Code	O _M	The status code of the MM at the time when the CDR is generated
Status Text	O _M	This field includes a more detailed technical status of the message at the point in time when the CDR is generated
Record Time Stamp	O _M	Time of generation of the CDR
Local Record Sequence Number	O _M	Consecutive record number created by this node. The number is allocated sequentially including all CDR types
Record extensions	O _M	A set of network/manufacturer specific extensions to the record. Conditioned upon the existence of an extension

6.1.2 MMS records for Recipient MMS R/S

6.1.2.0 General

The following subclauses specify CDRs created in the Recipient MMS R/S based on messages flowing over the MM1 and MM4 interfaces. The CDRs referring to MM4 messages (Recipient MM4 *** CDR) are created only if the Originator and Recipient MMS R/Ss communicate over the MM4 interface (i.e. the Recipient MMS R/S is not also the Originator MMS R/S). The CDRs referring to MM1 messages (Recipient MM1 *** CDR) are created regardless of

whether the Recipient MMS R/S is also the Originator MMS R/S or not. Unless otherwise specified the CDR parameters are copied from the corresponding MM1 or MM4 message parameters as applicable.

6.1.2.1 Recipient MM4 Forward record (R4F-CDR)

If enabled, a Recipient MM4 Forward R4F-CDR shall be produced in the Recipient MMS R/S if and when the Recipient MMS R/S receives an MM4_forward.REQ from the Originator MMS R/S.

Table 6.1.2.1.1 : Recipient MM4 Forward record (R4F-CDR)

Field	Category	Description
Record Type	M	Recipient MM4 Forward record
Recipient MMS Relay/Server Address	M	IP address or domain name of the Recipient MMS R/S
Originator MMS Relay/Server Address	M	IP address or domain name of the Originator MMS R/S
Message ID	M	The MM identification provided by the Originator MMS R/S
3GPP MMS Version	O _M	The MMS version of the Originator MMS R/S
Originator address	M	The address of the originator MMS User Agent of the MM
Recipients address list	M	The address(es) of the recipient MMS User Agent(s) of the -MM
Content type	M	The content type of the MM content
MM component list	O _M	The list of media components with volume size
Message size	M	The total size of the MM content
Message class	C	The class selection such as personal, advertisement, information service
Submission Time	M	The time at which the MM was submitted or forwarded as specified in the MM4_forward.REQ
Time of Expiry	C	The desired date of expiry or duration of time prior to expiry for the MM if specified by the originator MMS User Agent
Delivery Report Requested	M	This field indicates whether a delivery report has been requested by the originator MMS User Agent or not
Priority	C	The priority (importance) of the message if specified by the originator MMS User Agent
Sender visibility	M	A request to show or hide the sender's identity when the message is delivered to the MM recipient if the originator MMS User Agent has requested her address to be hidden from the recipient
Read reply Requested	M	A request for read-reply report if the originator MMS User Agent has requested a read-reply report for the MM
Request status code	M	The status of the request to route forward the MM. If the MM4_forward.REQ is responded by an MM4_forward.RES, this shall be the same information as specified in the Request Status Code information element in the MM4_forward.RES
Status Text	C	This field includes a more detailed technical status of the message at the point in time when the CDR is generated. If the MM4_forward.REQ is responded by an MM4_forward.RES, this shall be the same information as specified in the Status Text information element in the MM4_forward.RES corresponding to the Request Status Code
Acknowledgement Request	M	Request for MM4_forward.RES
Forward_counter	C	A counter indicating the number of times the particular MM was forwarded
Forwarding address	C	The address(es) of the forwarding MMS User Agent(s). Multiple addresses are possible. In the multiple address case this is a Sequential list of the address(es) of the forwarding MMS User Agents who forwarded the same MM
Record Time stamp	M	Time of generation of the CDR
Local Record Sequence Number	O _M	Consecutive record number created by this node. The number is allocated sequentially including all CDR types
Record extensions	O _C	A set of network/manufacturer specific extensions to the record. Conditioned upon the existence of an extension

6.1.2.2 Recipient MM1 Notification Request record (R1NRq-CDR)

If enabled, a Recipient MM1 Notification Request R1NRq-CDR shall be produced in the Recipient MMS R/S if and when the Recipient MMS R/S sends an MM1_notification.REQ to the Recipient MMS User Agent.

Table 6.1.2.2.1: Recipient MM1 Notification Request record (R1NRq -CDR)

Field	Category	Description
Record Type	M	Recipient MM1 Notification Request record
Recipient MMS R/S Address	M	IP address or domain name of the Recipient MMS R/S
Message ID	M	The MM identification provided by the Originator MMS R/S
Reply Charging ID	C	This field is present in the CDR only if the MM is a reply-MM to an original MM. The Reply-Charging ID is the Message ID of the original MM
Sender address	M	The address of the MMS User Agent as used in the MM1_notification.REQ. This parameter is present in the CDR regardless of address hiding
Recipient address	M	The address of the MM recipient of the MM
Access Correlation	O _M	A unique identifier delivered by the used access network domain of the Recipient MMS User Agent
Message class	M	The class selection such as personal, advertisement, information service; default = personal
MM component list	O _M	The list of media components with volume size
Message size	O _M	The total size of the MM content
Time of Expiry	O _M	The date of expiry or duration of time prior to expiry for the MM
Message Reference	M	A reference, e.g., URI, for the MM
Delivery Report Requested	O _M	This field indicates whether a delivery report is requested or not as specified in the MM1_notification.REQ
Reply Charging	O _C	Information that a reply to this particular original MM is free of charge as specified in the MM1_notification.REQ
Reply Deadline	O _C	In case of reply-charging the latest time of submission of a reply granted to the recipient as specified in the MM1_notification.REQ
Reply Charging-Size	O _C	In case of reply-charging the maximum size of a reply-MM granted to the recipient as specified in the MM1_notification.REQ
MM Status Code	O _M	The status code of the MM at the time when the CDR is generated
Status Text	O _M	This field includes a more detailed technical status of the message at the point in time when the CDR is generated.
MSCF Information	O _C	A set of parameters provided by the MSCF when interacting with the MMS R/S via the MM10 interface prior to the MM1_notification.REQ
Applic-ID	O _C	If present, this field holds the identification of the destination application that the underlying MMS abstract message was addressed to.
Reply-Applic-ID	O _C	If present, this parameter indicates a "reply path", i.e. the identifier of the application to which delivery reports, read-reply reports and reply-MMs are addressed.
Aux-Applic-Info	O _C	If present, this parameter indicates additional application/implementation specific control information.
Replace-ID	O _C	If present, this parameter holds the Identifier of the previous MM that is replaced by the current MM, if requested by a VASP
Record Time Stamp	O _M	Time of generation of the CDR
Local Record Sequence Number	O _M	Consecutive record number created by this node. The number is allocated sequentially including all CDR types
Serving network identity	O _C	If present this parameter holds the SGSN PLMN Identifier (MCC and MNC) used during this record
RAT Type	O _C	The radio access technology used during this record.
MS Time Zone	O _C	This field contains the MS Time Zone the MMS User Agent is currently located, if available.
VAS-Id	O _C	This field indicates the VAS that originated the MM. Only present in MM1 Retrieval and if the MM was received over an MM7 interface.
VASP-Id	O _C	This field indicates the VASP that originated the MM. Only present in MM1 Retrieval and if the MM was received over an MM7 interface.
Record extensions	O _C	A set of network/manufacture specific extensions to the record. Conditioned upon the existence of an extension

6.1.2.3 Recipient MM1 Notification Response record (R1NRs-CDR)

If enabled, a Recipient MM1 Notification Response R1NRs-CDR shall be produced in the Recipient MMS R/S if and when the Recipient MMS R/S receives an MM1_notification.RES from the Recipient MMS User Agent.

Table 6.1.2.3.1: Recipient MM1 Notification Response record (R1NRs-CDR)

Field	Category	Description
Record Type	M	Recipient MM1 Notification Response record
Recipient MMS Relay/Server Address	M	IP address or domain name of the Recipient MMS R/S
Message ID	M	The MM identification provided by the Originator MMS R/S
Recipient address	M	The address of the MM recipient of the MM
Access Correlation	O _M	A unique identifier delivered by the used access network domain of the Recipient MMS User Agent
Report allowed	C	Request to allow or disallow the sending of a delivery report to the MM Originator if specified in the MM1_notification_RES
MM Status Code	O _M	The status code of the MM at the time when the CDR is generated
Status Text	O _M	This field includes a more detailed technical status of the message at the point in time when the CDR is generated
Record Time Stamp	O _M	Time of generation of the CDR
Local Record Sequence Number	O _M	Consecutive record number created by this node. The number is allocated sequentially including all CDR types
Serving network identity	O _C	If present this parameter holds the SGSN PLMN Identifier (MCC and MNC) used during this record
RAT Type	O _C	The radio access technology used during this record.
MS Time Zone	O _C	This field contains the MS Time Zone the MMS User Agent is currently located, if available.
Record extensions	O _C	A set of network/manufacture specific extensions to the record. Conditioned upon the existence of an extension

6.1.2.4 Recipient MM1 Retrieve record (R1Rt-CDR)

If enabled, a Recipient MM1 Retrieve R1Rt-CDR shall be produced in the Recipient MMS R/S if and when the Recipient MMS R/S has sent an MM1_retrieve.RES to the Recipient MMS User Agent. That is, the CDR is created upon completion of transmission of the MM1_retrieve.RES.

Table 6.1.2.4.1: Recipient MM1 Retrieve record (R1Rt-CDR)

Field	Category	Description
Record Type	M	Recipient MM1 Retrieve record
Recipient MMS R/S Address	M	IP address or domain name of the Recipient MMS R/S.
Message ID	M	The MM identification provided by the Originator MMS R/S.
Reply Charging ID	C	This field is present in the CDR only if the MM is a reply-MM to an original MM. The Reply-Charging ID is the Message ID of the original MM.
Sender address	C	The address of the MMS User Agent as used in the MM1_retrieve.RES, or the address of VASP as used in the MM7_submit.REQ. This parameter is present in the CDR regardless of address hiding.
Recipient address	M	The address of the Recipient MM User Agent of the MM.
Access Correlation	O _M	A unique identifier delivered by the used access network domain of the originator MMS User Agent.
Message Reference	M	Location of the content of the MM to be retrieved as specified in the MM1_retrieve.REQ.
Original MM Content	M	This parameter contains a set of information elements related to the original MM.
Content type	M	The content type of the MM content.
Message size	O _M	The total size of the original MM content.
MM component list	O _M	The list of media components with volume size.
Adapted MM Content	C	If the MM content is adapted prior to its retrieval, this parameter is present and contains the resulting set of information elements related to the adapted MM.
Content type	C	The content type of the adapted MM content.
Message size	O _C	The total size of the adapted MM content.
MM component list	O _C	The list of media components with volume size of the adapted MM.
Message class	O _C	The class of the message (e.g., personal, advertisement, information service) if specified in the MM1_retrieve.RES
Submission Time	M	The time at which the MM was submitted or forwarded as specified in the MM1_retrieve.RES
Delivery report Requested	O _M	A request for delivery report as specified in the Delivery Report information element in the MM1_retrieve.RES
Priority	O _C	The priority (importance) of the message if specified in the MM1_retrieve.RES
Read reply Requested	O _C	A request for read-reply report if specified in the Read Reply information element in the MM1_retrieve.RES
MM Status Code	O _M	The status code of the MM at the time when the CDR is generated
Status Text	O _M	This field includes a more detailed technical status of the message at the point in time when the CDR is generated
Applic-ID	O _C	If present, this field holds the identification of the destination application that the underlying MMS abstract message was addressed to.
Reply-Applic-ID	O _C	If present, this parameter indicates a "reply path", i.e. the identifier of the application to which delivery reports, read-reply reports and reply-MMs are addressed.
Aux-Applic-Info	O _C	If present, this parameter indicates additional application/implementation specific control information.
Replace-ID	O _C	If present, this parameter holds the Identifier of the previous MM that is replaced by the current MM, if requested by a VASP
Reply Deadline	O _C	In case of reply-charging the latest time of submission of a reply granted to the recipient as specified in the MM1_retrieve.RES
Reply Charging-Size	O _C	In case of reply-charging the maximum size of a reply-MM granted to the recipient as specified in the MM1_retrieve.RES
Duration Of Transmission	O _M	The time used for transmission of the MM between the User Agent and the MMS R/S
Record Time Stamp	O _M	Time of generation of the CDR
Local Record Sequence Number	O _M	Consecutive record number created by this node. The number is allocated sequentially including all CDR types
Serving network identity	O _C	If present this parameter holds the SGSN PLMN Identifier (MCC and MNC) used during this record
RAT Type	O _C	The radio access technology used during this record.
MS Time Zone	O _C	This field contains the MS Time Zone the MMS User Agent is currently located, if available.
VAS-Id	O _C	This field indicates the VAS that originated the MM. Only present in MM1 Retrieval and if the MM was received over an MM7 interface.
VASP-Id	O _C	This field indicates the VASP that originated the MM. Only present in MM1 Retrieval and if the MM was received over an MM7 interface.

Field	Category	Description
Record extensions	O _C	A set of network/matrix manufacturer specific extensions to the record. Conditioned upon the existence of an extension

6.1.2.5 Recipient MM1 Acknowledgement record (R1A-CDR)

If enabled, a Recipient MM1 Acknowledgement R1A-CDR shall be produced in the Recipient MMS R/S if and when the Recipient MMS R/S receives an MM1_acknowledgement.REQ from the Recipient MMS User Agent.

Table 6.1.2.5.1: Recipient MM1 Acknowledgement record (R1A-CDR)

Field	Category	Description
Record Type	M	Recipient MM1 Acknowledgement record
Recipient MMS Relay/Server Address	M	IP address or domain name of the Recipient MMS R/S
Message ID	M	The MM identification provided by the Originator MMS R/S
Recipient address	M	The address of the Recipient MM User Agent of the MM
Access Correlation	O _M	A unique identifier delivered by the used access network domain of the originator MMS User Agent.
Report allowed	C	Request to allow or disallow the sending of a delivery report to the MM Originator if specified in the MM1_acknowledgement.RES
MM Status Code	O _M	The status code of the MM at the time when the CDR is generated
Status Text	O _M	This field includes a more detailed technical status of the message at the point in time when the CDR is generated
Record Time Stamp	O _M	Time of generation of the CDR
Local Record Sequence Number	O _M	Consecutive record number created by this node. The number is allocated sequentially including all CDR types
Serving network identity	O _C	If present this parameter holds the SGSN PLMN Identifier (MCC and MNC) used during this record
RAT Type	O _C	The radio access technology used during this record.
MS Time Zone	O _C	This field contains the MS Time Zone the MMS User Agent is currently located, if available.
Record extensions	O _C	A set of network/matrix manufacturer specific extensions to the record. Conditioned upon the existence of an extension

6.1.2.6 Recipient MM4 Delivery Report Request record (R4DRq-CDR)

If enabled, a Recipient MM4 Delivery Report Request R4DRq-CDR shall be produced in the Recipient MMS R/S if and when the Recipient MMS R/S sends an MM4_delivery_report.REQ to the Originator MMS R/S.

Table 6.1.2.6.1: Recipient MM4 Delivery Report Request record (R4DRq-CDR)

Field	Category	Description
Record Type	M	Recipient MM4 Delivery report Request record
Recipient MMS Relay/Server Address	M	IP address or domain name of the Recipient MMS R/S
Originator MMS Relay/Server Address	M	IP address or domain name of the Originator MMS R/S
Message ID	M	The MM identification provided by the Originator MMS R/S
3GPP MMS Version	O _M	The MMS version of the Recipient MMS R/S
Originator address	M	The address of the originator MMS User Agent of the MM
Recipient address	M	The address of the MM recipient of the MM
MM Date and time	O _M	Date and time the MM was handled (retrieved, expired, rejected, etc.)
Acknowledgement Request	M	Request for MM4_delivery_report.RES
MM Status Code	O _M	The status code of the MM as sent in the MM4_delivery_report.REQ
Status Text	O _C	This field includes the status text as sent in the MM4_delivery_report.REQ corresponding to the MM Status Code
Record Time Stamp	O _M	Time of generation of the CDR
Local Record Sequence Number	O _M	Consecutive record number created by this node. The number is allocated sequentially including all CDR types
Record extensions	O _M	A set of network/matrix manufacturer specific extensions to the record. Conditioned upon the existence of an extension

6.1.2.7 Recipient MM4 Delivery Report Response record (R4DRs-CDR)

If enabled, a Recipient MM4 Delivery Report Response R4DRs-CDR shall be produced in the Recipient MMS R/S if and when the Recipient MMS R/S receives an MM4_delivery_report.RES from the Originator MMS R/S.

Table 6.1.2.7.1: Recipient MM4 Delivery Report Response record (R4DRs-CDR)

Field	Category	Description
Record Type	M	Recipient MM4 Delivery report Response record
Recipient MMS Relay/Server Address	M	IP address or domain name of the Recipient MMS R/S
Originator MMS Relay/Server Address	M	IP address or domain name of the Originator MMS R/S
Message ID	M	The MM identification provided by the Originator MMS R/S
3GPP MMS Version	O _M	The MMS version of the Originator MMS R/S
Request Status Code	O _M	The status code of the MM as received in the MM4_delivery_report.RES
Status Text	O _C	This field includes the status text as received in the MM4_delivery_report.RES corresponding to the Request Status Code
Record Time Stamp	O _M	Time of generation of the CDR
Local Record Sequence Number	O _M	Consecutive record number created by this node. The number is allocated sequentially including all CDR types
Record extensions	O _C	A set of network/manufacture specific extensions to the record. Conditioned upon the existence of an extension

6.1.2.8 Recipient MM1 Read Reply Recipient record (R1RR-CDR)

If enabled, a Recipient MM1 Read Reply Recipient R1RR-CDR shall be produced in the Recipient MMS R/S if and when the Recipient MMS R/S receives an MM1_read_reply_recipient.REQ from the Recipient MMS User Agent.

Table 6.1.2.8.1: Recipient MM1 Read Reply Recipient record (R1RR-CDR)

Field	Category	Description
Record Type	M	Recipient MM1 Read reply Recipient record
Recipient MMS Relay/Server Address	M	IP address or domain name of the Recipient MMS R/S
Message ID	M	The MM identification provided by the Originator MMS R/S
Recipient address	M	The address of the Recipient MM User Agent of the MM
Originator address	M	The address of the MM Originator of the original MM, i.e., the recipient of the read-reply report
Access Correlation	O _M	A unique identifier delivered by the used access network domain of the originator MMS User Agent
MM Status Code	O _M	The status code of the MM at the time when the CDR is generated
Status Text	O _M	This field includes a more detailed technical status of the message at the point in time when the CDR is generated
Applic-ID	O _C	If present, this field holds the identification of the destination application that the underlying MMS abstract message was addressed to.
Reply-Applic-ID	O _C	If present, this parameter indicates a "reply path", i.e. the identifier of the application to which delivery reports, read-reply reports and reply-MMs are addressed.
Aux-Applic-Info	O _C	If present, this parameter indicates additional application/implementation specific control information.
Record Time Stamp	O _M	Time of generation of the CDR
Local Record Sequence Number	O _M	Consecutive record number created by this node. The number is allocated sequentially including all CDR types
Serving network identity	O _C	If present this parameter holds the SGSN PLMN Identifier (MCC and MNC) used during this record
RAT Type	O _C	The radio access technology used during this record.
MS Time Zone	O _C	This field contains the MS Time Zone the MMS User Agent is currently located, if available.
Record extensions	O _C	A set of network/manufacture specific extensions to the record. Conditioned upon the existence of an extension

6.1.2.9 Recipient MM4 Read Reply Report Request record (R4RRq-CDR)

If enabled, a Recipient MM4 Read Reply Report Request R4RRq-CDR shall be produced in the Recipient MMS R/S if and when the Recipient MMS R/S sends an MM4_read_reply_report.REQ to the Originator MMS R/S.

Table 6.1.2.9.1: Recipient MM4 Read Reply Report Request record (R4RRq-CDR)

Field	Category	Description
Record Type	M	Recipient MM4 read reply report Request record
Recipient MMS Relay/Server Address	M	IP address or domain name of the Recipient MMS R/S
Originator MMS Relay/Server Address	M	IP address or domain name of the Originator MMS R/S
Message ID	M	The MM identification provided by the Originator MMS R/S
3GPP MMS Version	O _M	The MMS version of the Recipient MMS R/S
Originator address	M	The address of the originator MMS User Agent of the MM
Recipient address	M	The address of the MM recipient of the MM
MM Date and time	O _M	Date and time the MM was handled (retrieved, expired, rejected, etc.)
Acknowledgement Request	M	Request for MM4_read_reply_report.RES
MM Status Code	O _M	The status code of the MM at the time when the CDR is generated
Status Text	O _M	This field includes a more detailed technical status of the message at the point in time when the CDR is generated
Record Time Stamp	O _M	Time of generation of the CDR
Local Record Sequence Number	O _M	Consecutive record number created by this node. The number is allocated sequentially including all CDR types
Record extensions	O _C	A set of network/manufacturer specific extensions to the record. Conditioned upon the existence of an extension

6.1.2.10 Recipient MM4 Read Reply Report Response record (R4RRs-CDR)

If enabled, a Recipient MM4 Read Reply Report Response R4RRs-CDR shall be produced in the Recipient MMS R/S if and when the Recipient MMS R/S receives an MM4_read_reply_report.RES from the Originator MMS R/S.

Table 6.1.2.10.1: Recipient MM4 DeliveryRead Reply Report Response record (R4DRRs-CDR)

Field	Category	Description
Record Type	M	Recipient MM4 Read reply report Response record
Recipient MMS Relay/Server Address	M	IP address or domain name of the Recipient MMS R/S
Originator MMS Relay/Server Address	M	IP address or domain name of the Originator MMS R/S
Message ID	M	The MM identification provided by the Originator MMS R/S
3GPP MMS Version	O _M	The MMS version of the Originator MMS R/S
Request Status Code	O _M	The status code of the MM as received in the MM4_read_reply_report.RES
Status Text	O _C	This field includes a more detailed technical status if received in the MM4_read_reply_report.RES corresponding to the Request Status Code
Record Time Stamp	O _M	Time of generation of the CDR
Local Record Sequence Number	O _M	Consecutive record number created by this node. The number is allocated sequentially including all CDR types
Record extensions	O _C	A set of network/manufacturer specific extensions to the record. Conditioned upon the existence of an extension

6.1.2.11 Recipient MM1 Cancellation record (R1C-CDR)

If enabled, a Recipient MM1 Cancellation R1C-CDR shall be produced in the Recipient MMS R/S if and when the Recipient MMS R/S receives an MM1_Cancel.RES from the Recipient MMS User Agent.

Table 6.1.2.11.1: Recipient MM1 Cancellation record (R1C-CDR)

Field	Category	Description
Record Type	M	Recipient MM1 Cancellation record
Recipient MMS Relay/Server Address	M	IP address or domain name of the Recipient MMS R/S
Originator MMS Relay/Server Address	M	IP address or domain name of the Originator MMS R/S
Cancel ID	M	The identification of the cancelled MM
3GPP MMS Version	O _M	The MMS version of the Originator MMS R/S
Request Status Code	O _M	The status code of the cancellation as received in the MM1_Cancel.RES
Record Time Stamp	O _M	Time of generation of the CDR
Local Record Sequence Number	O _M	Consecutive record number created by this node. The number is allocated sequentially including all CDR types
Record extensions	O _C	A set of network/manufacture specific extensions to the record. Conditioned upon the existence of an extension

6.1.2.12 Recipient MM Deletion record (RMD-CDR)

If enabled, a Recipient MM Deletion RMD-CDR shall be produced in the Recipient MMS R/S if and when:

- 1) the Recipient MMS R/S decides to abandon processing of the MM at any point after receiving the corresponding MM4_forward.REQ; or
- 2) the Recipient MMS R/S decides to delete the MM because of expiry of storage time, which may either be indicated in the submit request or governed by operator procedure(e.g. after successful MM delivery); or
- 3) The Recipient MMS R/S decides to delete the MM prior to the expiry of storage time because it received a request to delete a deferred MM (i.e. MM for that retrieval has been deferred) from the recipient MMS User Agent in the corresponding MM1_delete.REQ and before an MM1_cancel.REQ, if any, is sent to the recipient MMS User Agent.

Abandoning the processing of the MM implies that there remains no knowledge of the MM in the Recipient MMS R/S.

The status code indicates the precise reason for abandoning or deleting the MM with respect to the MMS transactions specified in TS 23.140 [201].

A special case is where the Recipient MMS R/S is also the Forwarding MMS R/S. In this case only the Originator MM Deletion CDR specified in clause 6.1.1.8 is required.

Table 6.1.2.12.1: Recipient MM Deletion record (RMD-CDR)

Field	Category	Description
Record Type	M	Recipient MM Deletion record
Originator MMS Relay/Server Address	M	IP address or domain name of the Originator MMS R/S
Recipient MMS Relay/Server Address	O _M	IP address or domain name of the Recipient MMS R/S
Message ID	M	The MM identification provided by the Originator MMS R/S
Message size	O _M	The total size of the MM content
MM Status Code	O _M	The status code of the MM at the time when the CDR is generated
Status Text	O _M	This field includes a more detailed technical status of delivering the message
Record Time Stamp	O _M	Time of generation of the CDR
Local Record Sequence Number	O _M	Consecutive record number created by this node. The number is allocated sequentially including all CDR types
Record extensions	O _C	A set of network/manufacture specific extensions to the record. Conditioned upon the existence of an extension

6.1.3 MMS records for Forwarding MMS R/S

6.1.3.1 Forwarding record (F-CDR)

If enabled, a Forwarding F-CDR shall be produced in the Forwarding MMS R/S on receipt of an MM1_forward.REQ if and when the Forwarding MMS R/S responds with an MM1_forward.RES indicating acceptance.

Table 6.1.3.1 : MM Forwarding record (F-CDR)

Field	Category	Description
Record Type	M	MM Forwarding record
Forwarding MMS Relay/Server Address	M	IP address or domain name of the Forwarding MMS R/S
Message ID	M	The MM identification provided by the Originator MMS R/S
Forwarding address	M	One or more addresses of the forwarding MMS User Agent (i.e., of the MMS User Agent that has sent the MM1_forward.REQ)
Recipients address list	M	The address(es) of the Recipient MMS User Agent(s) of the forwarded MM. Multiple addresses are possible
Charge Information	O _M	The charged party indication and charge type
Time of Expiry	O _C	The desired date of expiry or duration of time prior to expiry for the MM if specified by the forwarding MMS User Agent
Earliest Time Of Delivery	O _C	This field contains either the earliest time to deliver the MM or the number of seconds to wait before delivering the MM
Delivery Report Requested	O _M	This field indicates whether a delivery report has been requested by the forwarding MMS User Agent or not
Read reply requested	O _M	A request for read-reply report as specified in the MM1_forward.REQ
Message reference	M	A reference, e.g., URI, for the MM as specified in the MM1_forward.REQ
MM Status Code	O _M	The status code of the MM at the time when the CDR is generated
Status Text	O _M	This field includes a more detailed technical status of the message at the point in time when the CDR is generated
Record Time Stamp	O _M	Time of generation of the CDR
Local Record Sequence Number	O _M	Consecutive record number created by this node. The number is allocated sequentially including all CDR types
MMBox Storage Information	O _C	A set of parameters related to the MMBox management. This parameter is only present if the MMBox feature is supported by the MMS R/S and storage of the MM was requested by the forwarding MMS User Agent (i.e., of the MMS User Agent that has sent the MM1_forward.REQ)
Reply Charging	O _C	A request for reply-charging if specified by the forwarding MMS User Agent
Reply Deadline	O _C	In case of reply-charging the latest time of submission of replies granted to the recipient(s) as specified by the forwarding MMS User Agent
Reply Charging Size	O _C	In case of reply-charging the maximum size for reply-MM(s) granted to the recipient(s) as specified by the forwarding MMS User Agent
Serving network identity	O _M	SGSN PLMN Identifier (MCC and MNC) used during this record
Record extensions	O _C	A set of network/manufacture specific extensions to the record. Conditioned upon the existence of an extension

6.1.4 Service records for MMS R/S supporting MMBoxes

6.1.4.1 MMBox MM1 Store record (Bx1S-CDR)

If enabled, an MMBox MM1 Store Bx1S-CDR shall be produced in the MMS R/S if and when the MMS R/S responds with an MM1_mmbox_store.RES to the MMS User Agent.

Table 6.1.4.1.1: MMBox MM1 Store record (Bx1S-CDR)

Field	Category	Description
Record Type	M	MMBox MM1 Store record
MMS Relay/Server Address	M	An address of the MMS R/S
Managing address	M	The address of the managing MMS User Agent (i.e., of the MMS User Agent that has sent the MM1_mmbox_store.REQ)
Access Correlation	O _M	A unique identifier delivered by the used access network domain of the originator MMS User Agent
Content type	O _M	The content type of the MM content
Message size	O _M	The size of the MM
Message Reference	O _M	A reference to the newly stored or updated MM, suitable for subsequent usage (e.g.: with MM1_retrieve.REQ and MM1_mmbox_delete.REQ)
MM State	O _M	The state of the MM. If not present when the Message Reference is from a notification request, defaults to New. No value is assumed when the Message Reference refers to an already stored MM
MM Flags	O _C	If available, the keyword flags of the MM. There are no defaults
Store status	O _C	The status code of the request to store the MM as received in the MM1_store.RES
Store Status Text	O _C	This field includes a more detailed technical description of the store status at the point in time when the CDR is generated. This field is only present if the store status is present
Sequence Number	O _M	Record number
Time Stamp	O _M	Time of generation of the CDR
Serving network identity	O _C	If present this parameter holds the SGSN PLMN Identifier (MCC and MNC) used during this record
RAT Type	O _C	The radio access technology used during this record.
MS Time Zone	O _C	This field contains the MS Time Zone the MMS User Agent is currently located, if available.
Record extensions	O _C	A set of network/manufacture specific extensions to the record

6.1.4.2 MMBox MM1 View record (Bx1V-CDR)

If enabled, an MMBox MM1 View Bx1V-CDR shall be produced in the MMS R/S if and when the MMS R/S has sent an MM1_mmbox_view.RES to the MMS User Agent.

Table 6.1.4.2.1: MMBox MM1 View record (Bx1V-CDR)

Field	Category	Description
Record Type	M	MMBox MM1 View record
MMS Relay/Server Address	M	An address of the MMS R/S.
Managing address	M	The address of the managing MMS User Agent (i.e., of the MMS User Agent that has sent the MM1_mmbox_view.REQ).
Access Correlation	O _M	A unique identifier delivered by the used access network domain of the originator MMS User Agent.
Attributes list	O _M	A list of information elements that are to be returned as a group for each MM to be listed in the MM1_mmbox_view.RES. If absent, the default list (i.e. Message ID, Date and time, Sender address, Subject, Message size, MM State, and MM Flags) shall apply.
Message Selection	O _M	A list of MM State or MM Flags keywords (e.g. new or draft) or a list of Message Reference by which MMs within the MMBox can be selected. If both are absent, a listing of all MMs currently stored within the MMBox shall be selected.
Start	O _M	A number, indicating the index of the first MM of those selected to have information elements returned in the response. If this is absent, the first item selected is returned.
Limit	O _M	A number indicating the maximum number of selected MMs to their information elements returned in the response. If this is absent, information elements from all remaining MMs are returned.
Totals requested	O _M	This field indicates whether the current total number of messages and/or size contained by the MMBox has been requested by the managing MMS User Agent.
Quotas requested	O _M	This field indicates whether the current message and/or size quotas (i.e. the maximum number of messages allowed and/or the maximum size allowed) has been requested by the managing MMS User Agent.
MM listing	O _M	The requested listing of the selected MMs, which shall be one or more groups of information elements, one for each MM listed. Each MM group shall include: a Message Reference, and may include additional information elements as well. If absent, no MMs were found or selected.
Request Status Code	O _M	The status code of the request to view the MM as received in the MM1_view.RES.
Status Text	O _C	This field includes the status text as received in the MM1_view.RES corresponding to the Request Status Code. Present only if provided in the MM1_view.RES.
Totals	O _C	The total number of messages and/or octets for the MMBox, identified with Messages or Octets, respectively, depending upon the presence of Totals in the request.
Quotas	O _C	The quotas of the MMBox in messages and/or octets identified with Messages or Octets, respectively, depending upon the presence of Quotas in the request.
Sequence Number	O _M	Record number.
Time Stamp	O _M	Time of generation of the CDR.
Serving network identity	O _C	If present this parameter holds the SGSN PLMN Identifier (MCC and MNC) used during this record.
RAT Type	O _C	The radio access technology used during this record.
MS Time Zone	O _C	This field contains the MS Time Zone the MMS User Agent is currently located, if available.
Record extensions	O _C	A set of network/manufacture specific extensions to the record.

6.1.4.3 MMBox MM1 Upload record (Bx1U-CDR)

If enabled, an MMBox MM1 Upload Bx1U-CDR shall be produced in the MMS R/S if and when the MMS R/S has sent an MM1_mmbox_upload.RES to the MMS User Agent.

Table 6.1.4.3.1: MMBox MM1 Upload record (Bx1U-CDR)

Field	Category	Description
Record Type	M	MMBox MM1 Upload record
MMS Relay/Server Address	M	An address of the MMS R/S.
Managing address	M	The address of the managing MMS User Agent (i.e., of the MMS User Agent that sends the MM1_mmbox_upload.REQ).
Access Correlation	O _M	A unique identifier delivered by the used access network domain of the originator MMS User Agent.
Message class	O _C	The class of the MM (e.g., personal, advertisement, information service) if provided by the MMS User Agent.
Upload Time	O _M	The time and date at which the MM was uploaded (time stamp).
Time of Expiry	O _C	The desired date of expiry or duration of time prior to expiry for the MM if specified by the originator MMS User Agent
Earliest Time Of Delivery	O _C	This field contains either the earliest time to deliver the MM or the number of seconds to wait before delivering the MM if specified by the originator MMS User Agent
Priority	O _C	This field indicates the priority (importance) of the message if specified by the MMS User Agent,
MM State	O _M	The state of the MM. Will default to the Draft state if absent
MM Flags	O _C	If available, the keyword flags of the MM. There are no defaults.
Content type	O _M	The content type of the MM content.
Message size	O _M	The size of the MM.
Message Reference	O _M	A reference to the newly stored MM, suitable for subsequent usage (e.g.: with MM1_retrieve.REQ, MM1_mmbox_delete.REQ, etc.).
Request Status Code	O _M	The status code of the request to view the MM as received in the MM1_upload.RES.
Status Text	O _C	This field includes the status text as received in the MM1_upload.RES corresponding to the Request Status Code. Present only if provided in the MM1_upload.RES.
Sequence Number	O _M	Record number.
Time Stamp	O _M	Time of generation of the CDR.
Serving network identity	O _C	If present this parameter holds the SGSN PLMN Identifier (MCC and MNC) used during this record.
RAT Type	O _C	The radio access technology used during this record..
MS Time Zone	O _C	This field contains the MS Time Zone the MMS User Agent is currently located, if available.
Record extensions	O _C	A set of network/manufacturer specific extensions to the record.

6.1.4.4 MMBox MM1 Delete record (Bx1D-CDR)

If enabled, an MMBox MM1 Delete Bx1D-CDR shall be produced in the MMS R/S if and when the MMS R/S has sent an MM1_mmbox_delete.RES to the MMS User Agent.

Table 6.1.4.4.1: MMBox MM1 Delete record (Bx1D-CDR)

Field	Category	Description
Record Type	M	MMBox MM1 Delete record
MMS Relay/Server Address	M	An address of the MMS R/S.
Managing address	M	The address of the managing MMS User Agent (i.e., of the MMS User Agent that sends the MM1_mmbox_upload.REQ).
Access Correlation	O _M	A unique identifier delivered by the used access network domain of the originator MMS User Agent.
Message Reference	O _C	A reference to the message in error, if any, to which the following information elements apply
Request Status Code	O _M	The status code of the request to view the MM as received in the MM1_delete.RES.
Status Text	O _C	This field includes the status text as received in the MM1_delete.RES corresponding to the Request Status Code. Present only if provided in the MM1_delete.RES.
Sequence Number	O _M	Record number.
Time Stamp	O _M	Time of generation of the CDR.
Serving network identity	O _C	If present this parameter holds the SGSN PLMN Identifier (MCC and MNC) used during this record.
RAT Type	O _C	The radio access technology used during this record.
MS Time Zone	O _C	This field contains the MS Time Zone the MMS User Agent is currently located, if available.
Record extensions	O _C	A set of network/manufacturer specific extensions to the record.

6.1.5 MMS records for MMS VAS applications

6.1.5.0 General

The following subclauses specify CDRs created in the Originator MMS R/S based on messages flowing over the MM7 reference point. Unless otherwise specified, the CDR parameters are copied from the corresponding MM7 message parameters as applicable.

6.1.5.1 MM7 Submission record (MM7S-CDR)

If enabled, an MM7 Submission MM7S-CDR shall be produced in the MMS R/S for each MM submitted in an MM7_submit.REQ by a VASP to the MMS R/S if and when the MMS R/S responds with an MM7_submit.RES. The operator can configure whether this CDR, if enabled, shall only be created for MM7_submit.RES indicating acceptance of the submitted MM, or also for the unsuccessful submissions.

Table 6.1.5.1.1: MM7 Submission record (MM7S-CDR)

Field	Category	Description
Record Type	M	MM7 Submission record.
Originator MMS Relay/Server Address	M	.IP address or domain name of Originator MMS R/S.
Linked ID	C	This field is present in the CDR only if the MM defines a correspondence to a previous message that was delivered by the MMS R/S. The MM identification provided by the Originator MMS R/S.
VASP ID	M	Identifier of the VASP for this MMS R/S
VAS ID	M	Identifier of the originating application.
Message ID	M	The MM identification provided by the Originator MMS R/S.
Originator Address	M	The address of the MM Originator.
Recipients address list	M	The address(es) of the Recipient MMS User Agent(s) of the MM. Multiple addresses are possible if the MM is not a reply MM.
Service code	O _C	Charging related information that is used directly for billing purposes
Content type	M	The content type of the MM content.
Content Class	O _C	This field classifies the content of the MM to the smallest content class to which the MM belongs, if specified in the MM7_submit_REQ
DRM Content	O _C	This field indicates if the MM contains DRM-protected content, if specified in the MM7_submit_REQ
Adaptations	O _C	This field indicates if the Originator allows adaptation of the content (default True), if specified in the MM7_submit_REQ
MM component list	O _M	The list of media components with volume size.
Message size	M	The total size of the MM content.
Message class	O _C	The class selection such as personal, advertisement, information service if specified in the MM7_submit_REQ.
Charge Information	O _M	The charged party indication and charge type e.g. the sending, receiving, both parties, third party or neither.
Submission Time	O _C	The time at which the MM was submitted from the VASP if specified in the MM7_submit_REQ.
Time of Expiry	O _C	The desired date of expiry or duration of time prior to expiry for the MM if specified by the VASP
Earliest Time Of Delivery	C	This field contains either the earliest time to deliver the MM or the number of seconds to wait before delivering the MM if specified by the VASP
Delivery Report Requested	O _M	This field indicates whether a delivery report has been requested by the VASP or not.
Reply Charging	O _C	A request for reply-charging if specified by the VASP
Read reply requested	O _M	A request for read-reply report as specified in the MM7_submit.REQ.
Reply Deadline	O _C	In case of reply-charging the latest time of submission of replies granted to the recipient(s) as specified by the VASP
Reply Charging Size	O _C	In case of reply-charging the maximum size for reply-MM(s) granted to the recipient(s) as specified by the VASP
Priority	O _C	The priority (importance) of the message if specified by the VASP
Charged Party ID	O _C	The address of the third party which is expected to pay for the MM.
Message Distribution Indicator	O _C	This field is present if specified in the MM7_submit.REQ If set to "false" the VASP has indicated that content of the MM is not intended for redistribution. If set to "true" the VASP has indicated that content of the MM can be redistributed.
Request Status Code	O _M	The status code of the associated MM7_submit_REQ
Status Text	O _C	This field includes a more detailed technical status of the message at the point in time when the CDR is generated. This field is only present if the MM submission is rejected.
MSCF Information	O _C	A set of parameters provided by the MSCF when interacting with the MMS R/S via the MM10 interface prior to the MM7_submit.RES
Applic-ID	O _C	If present, this field holds the identification of the destination application that the underlying MMS abstract message was addressed to.
Reply-Applic-ID	O _C	If present, this parameter indicates a "reply path", i.e. the identifier of the application to which delivery reports, read-reply reports and reply-MMs are addressed.
Aux-Applic-Info	O _C	If present, this parameter indicates additional application/implementation specific control information.
Record Time Stamp	O _M	Time of generation of the CDR.
Local Record Sequence Number	O _M	Consecutive record number created by this node. The number is allocated sequentially including all CDR types.
Record extensions	O _C	A set of network/manufacturer specific extensions to the record. Conditioned upon the existence of an extension.

6.1.5.2 MM7 Deliver Request record (MM7DRq-CDR)

If enabled, a MM7 Deliver Request MM7DRq-CDR shall be produced in the MMS R/S if and when the MMS R/S sends an MM7_deliver.REQ to the Recipient MMS VASP.

Table 6.1.5.2.1: MM7 Deliver Request record (MM7DRq -CDR)

Field	Category	Description
Record Type	M	MM7 Deliver Request record.
Recipient MMS Relay/Server Address	M	IP address or domain name of the Recipient MMS R/S.
Linked ID	C	This field is present in the CDR only if the MM defines a correspondence to a previous message that was delivered by the MMS R/S. The MM identification provided by the Originator MMS R/S.
Reply Charging ID	C	This field is present in the CDR only if the MM is a reply-MM to an original MM. The Reply-Charging ID is the Message ID of the original MM.
Originator address	M	The address of the MMS User Agent as used in the MM7_deliver_REQ.
Recipient address	M	The address of the MM recipient of the MM.
MM component list	O _M	The list of media components with volume size.
Message size	O _M	The total size of the MM content.
Content type	M	The content type of the MM content.
MMS User Agent Capabilities	O _C	Information about the capabilities of the MMS User Agent that originated the MM. Present only if provided in the MM7_deliver.REQ.
Priority	O _C	The priority (importance) of the message if specified by the VASP
Applic-ID	O _C	If present, this field holds the identification of the destination application that the underlying MMS abstract message was addressed to.
Reply-Applic-ID	O _C	If present, this parameter indicates a "reply path", i.e. the identifier of the application to which delivery reports, read-reply reports and reply-MMs are addressed.
Aux-Applic-Info	O _C	If present, this parameter indicates additional application/implementation specific control information.
Record Time Stamp	O _M	Time of generation of the CDR
Local Record Sequence Number	O _M	Consecutive record number created by this node. The number is allocated sequentially including all CDR types.
Record extensions	O _C	A set of network/manufacture specific extensions to the record. Conditioned upon the existence of an extension.

6.1.5.3 MM7 Deliver Response record (MM7DRs-CDR)

If enabled, a MM7 Deliver Response MM7DRs-CDR shall be produced in the MMS R/S if and when the MMS R/S receives an MM7_deliver.RES from the Recipient MMS VASP.

Table 6.1.5.3.1: MM7 Deliver Response record (MM7DRs-CDR)

Field	Category	Description
Record Type	M	MM7 Deliver Response record.
Recipient MMS Relay/Server Address	M	IP address or domain name of the Recipient MMS R/S.
Message ID	M	The MM identification provided by the Originator MMS R/S.
Recipient address	M	The address of the MM recipient of the MM.
Service code	O _C	Charging related information that is used directly for billing purposes
Request Status Code	O _M	The status code of the associated MM7_deliver_REQ
Status Text	O _M	This field includes a more detailed technical status of the message at the point in time when the CDR is generated.
Record Time Stamp	O _M	Time of generation of the CDR
Local Record Sequence Number	O _M	Consecutive record number created by this node. The number is allocated sequentially including all CDR types.
Record extensions	O _C	A set of network/manufacture specific extensions to the record. Conditioned upon the existence of an extension.

6.1.5.4 MM7 Cancel record (MM7C-CDR)

If enabled, an MM7 Cancel MM7C-CDR shall be produced in the MMS R/S if and when the MMS R/S has sent an MM7_cancel.RES to the MMS VASP.

Table 6.1.5.4.1: MM7 Cancel record (MM7C-CDR)

Field	Category	Description
Record Type	M	MM7 Cancel record
Recipient MMS Relay/Server Address	M	IP address or domain name of Recipient MMS R/S.
VASP ID	M	Identifier of the VASP for this MMS R/S
VAS ID	M	Identifier of the originating application.
Message ID	M	The MM identification provided by the Originator MMS R/S.
Originator Address	M	The address of the MM Originator.
Content Class	O _C	This field classifies the content of the MM to the smallest content class to which the MM belongs, if specified in the MM7_cancel_REQ
DRM Content	O _C	This field indicates if the MM contains DRM-protected content, if specified in the MM7_cancel_REQ
Adaptations	O _C	This field indicates if the Originator allows adaptation of the content (default True), if specified in the MM7_cancel_REQ
Request Status Code	O _M	The status code of the associated MM7_cancel.REQ.
Status Text	O _C	This field includes the status text as received in the MM7_cancel.RES corresponding to the Request Status Code. Present only if provided in the MM7_cancel.RES.
Applic-ID	O _C	If present, this field holds the identification of the destination application that the underlying MMS abstract message was addressed to.
Reply-Applic-ID	O _C	If present, this parameter indicates a "reply path", i.e. the identifier of the application to which delivery reports, read-reply reports and reply-MMSs are addressed.
Aux-Applic-Info	O _C	If present, this parameter indicates additional application/implementation specific control information.
Sequence Number	O _M	Record number.
Time Stamp	O _M	Time of generation of the CDR.
Record extensions	O _C	A set of network/manufacture specific extensions to the record.

6.1.5.5 MM7 Replace record (MM7R-CDR)

If enabled, an MM7 Replace MM7R-CDR shall be produced in the MMS R/S if and when the MMS R/S has sent an MM7_replace.RES to the MMS VASP.

Table 6.1.5.5.1: MM7 Replace record (MM7R-CDR)

Field	Category	Description
Record Type	M	MM7 Replace record
Recipient MMS Relay/Server Address	M	IP address or domain name of Recipient MMS R/S.
VASP ID	M	Identifier of the VASP for this MMS R/S
VAS ID	M	Identifier of the originating application.
Message ID	M	The MM identification provided by the Originator MMS R/S.
Originator Address	M	The address of the MM Originator.
Service code	O _C	Charging related information that is used directly for billing purposes
Content type	M	The content type of the MM content.
Submission time	O _C	The time at which the MM was submitted from the VASP if specified in the MM7_replace_REQ.
Time of Expiry	O _C	The desired date of expiry or duration of time prior to expiry for the MM if specified by the VASP
Earliest Time Of Delivery	O _C	This field contains either the earliest time to deliver the MM or the number of seconds to wait before delivering the MM if specified by the VASP
Request Status Code	O _M	The status code of associated MM7_replace.REQ.
Status Text	O _C	This field includes the status text as received in the MM7_replace.RES corresponding to the Request Status Code. Present only if provided in the MM7_replace.RES.
Applic-ID	O _C	If present, this field holds the identification of the destination application that the underlying MMS abstract message was addressed to.
Reply-Applic-ID	O _C	If present, this parameter indicates a "reply path", i.e. the identifier of the application to which delivery reports, read-reply reports and reply-MMSs are addressed.
Aux-Applic-Info	O _C	If present, this parameter indicates additional application/implementation specific control information.
Sequence Number	O _M	Record number
Time Stamp	O _M	Time of generation of the CDR.
Record extensions	O _C	A set of network/manufacture specific extensions to the record.

6.1.5.6 MM7 Delivery Report Request record (MM7DRRq-CDR)

If enabled, a MM7 Delivery Report Request MM7DRRq-CDR shall be produced in the MMS R/S if and when the MMS R/S sends an MM7_delivery_report.REQ to the MMS VASP.

Table 6.1.5.6.1: MM7 Delivery Report Request record (MM7DRRq-CDR)

Field	Category	Description
Record Type	M	MM7 Delivery Report Request record.
Recipient MMS Relay/Server Address	O _M	IP address or domain name of the Recipient MMS R/S.
Message ID	M	The MM identification provided by the Originator MMS R/S.
Originator address	O _M	The address of the VAS that submitted the original MM.
Recipient address	M	The address of the MM recipient of the MM.
MM Date and time	M	Date and time the MM was handled (retrieved, expired, rejected, etc.) as specified in the MM7_delivery_report.REQ.
MM Status Code	M	The status code of the delivered MM as received in the MM7_delivery_report.RES.
MM Status Text	O _C	This field includes the status text as received in the MM7_delivery_report.RES corresponding to the MM Status Code. Present only if provided in the MM7_delivery_report.RES.
MMS User Agent Capabilities	O _C	Information about the capabilities of the MMS User Agent that originated the MM. Present only if provided in the MM7_delivery_report.REQ.
Applic-ID	O _C	If present, this field holds the identification of the destination application that the underlying MMS abstract message was addressed to.
Reply-Applic-ID	O _C	If present, this parameter indicates a "reply path", i.e. the identifier of the application to which delivery reports, read-reply reports and reply-MMs are addressed.
Aux-Applic-Info	O _C	If present, this parameter indicates additional application/implementation specific control information.
Record Time Stamp	O _M	Time of generation of the CDR
Local Record Sequence Number	O _M	Consecutive record number created by this node. The number is allocated sequentially including all CDR types.
Record extensions	O _C	A set of network/manufacture specific extensions to the record. Conditioned upon the existence of an extension.

6.1.5.7 MM7 Delivery Report Response record (MM7DRRs-CDR)

If enabled, an MM7 Delivery Report Response MM7DRRs-CDR shall be produced in the MMS R/S if and when the MMS R/S receives an MM7_delivery_report.RES from the MMS VASP.

Table 6.1.5.7.1: MM7 Delivery Report Response record (MM7DRRs-CDR)

Field	Category	Description
Record Type	M	MM7 Delivery Report Response record.
Recipient MMS Relay/Server Address	O _M	IP address or domain name of the Recipient MMS R/S.
Message ID	M	The MM identification provided by the Originator MMS R/S.
Originator address	O _M	The address of the VAS that submitted the original MM.
Recipient address	M	The address of the MM recipient of the MM.
Request Status Code	O _M	The status code of the associated MM7_delivery_report.REQ.
Status Text	O _C	This field includes the status text as received in the MM7_delivery_report.RES corresponding to the Request Status Code. Present only if provided in the MM7_delivery_report.RES.
Record Time Stamp	O _M	Time of generation of the CDR
Local Record Sequence Number	O _M	Consecutive record number created by this node. The number is allocated sequentially including all CDR types.
Record extensions	O _C	A set of network/manufacture specific extensions to the record. Conditioned upon the existence of an extension.

6.1.5.8 MM7 Read Reply Report Request record (MM7RRq-CDR)

If enabled, a MM7 Read Reply Report Request MM7RRq-CDR shall be produced in the MMS R/S if and when the Recipient MMS R/S sends an MM7_read_reply_report.REQ to the MMS VASP.

Table 6.1.5.8.1: MM7 Read Reply Report Request record (MM7RRq-CDR)

Field	Category	Description
Record Type	M	MM7 Read reply report Requestrecord.
Recipient MMS Relay/Server Address	O _M	IP address or domain name of the Recipient MMS R/S.
Message ID	M	The MM identification provided by the Originator MMS R/S.
Originator address	O _M	The address of the VAS that submitted the original MM.
Recipient address	M	The address of the MM recipient of the MM.
MM Date and time	M	Date and time the MM was handled (retrieved, expired, rejected, etc.) as specified in the MM7_Read_reply_report.REQ.
Read Status	M	The status of the MM (e.g. Read, deleted without being read, etc.) as sent in the MM7_read_reply_report.REQ.
MM Status Text	O _C	This field includes the status text as received in the MM7_read_reply_report.RES corresponding to the Read Status. Present only if provided in the MM7_read_reply_report.REQ.
Applic-ID	O _C	If present, this field holds the identification of the destination application that the underlying MMS abstract message was addressed to.
Reply-Applic-ID	O _C	If present, this parameter indicates a "reply path", i.e. the identifier of the application to which delivery reports, read-reply reports and reply-MMs are addressed.
Aux-Applic-Info	O _C	If present, this parameter indicates additional application/implementation specific control information.
Record Time Stamp	O _M	Time of generation of the CDR
Local Record Sequence Number	O _M	Consecutive record number created by this node. The number is allocated sequentially including all CDR types.
Record extensions	O _C	A set of network/manufacture specific extensions to the record. Conditioned upon the existence of an extension.

6.1.5.9 MM7 Read Reply Report Response record (MM7RRs-CDR)

If enabled, an MM7 Read Reply Report Response MM7RRs-CDR shall be produced in the MMS R/S if and when the MMS R/S receives an MM7_Read_reply_report.RES from the Originator MMS VASP.

Table 6.1.5.9.1: MM7 Read Reply Report Response record (MM7RRs-CDR)

Field	Category	Description
Record Type	M	MM7 Read reply report Response record.
Recipient MMS Relay/Server Address	O _M	IP address or domain name of the Recipient MMS R/S.
Message ID	M	The MM identification provided by the Originator MMS R/S.
Originator address	O _M	The address of the VAS that submitted the original MM.
Recipient address	M	The address of the MM recipient of the MM.
Request Status Code	O _M	The status code of the associated MM7_read_reply_report.REQ.
Status Text	O _C	This field includes the status text as received in the MM7_read_reply_report.RES corresponding to the Request Status Code. Present only if provided in the MM7_read_reply_report.RES.
Record Time Stamp	O _M	Time of generation of the CDR
Local Record Sequence Number	O _M	Consecutive record number created by this node. The number is allocated sequentially including all CDR types.
Record extensions	O _C	A set of network/manufacture specific extensions to the record. Conditioned upon the existence of an extension.

6.1.5.10 MM7 Extended Cancel record (MM7EC-CDR)

If enabled, an MM7 Extended Cancel MM7EC-CDR shall be produced in the MMS R/S if and when the MMS R/S has sent an MM7_extended_cancel.RES to the MMS VASP.

Table 6.1.5.10.1: MM7 Extended Cancel record (MM7EC-CDR)

Field	Category	Description
Record Type	M	MM7 Extended Cancel record
Recipient MMS Relay/Server Address	M	IP address or domain name of Recipient MMS R/S.
VASP ID	M	Identifier of the VASP for this MMS R/S
VAS ID	M	Identifier of the originating application.
Cancel ID	M	The identification of the cancelled MM
Request Status Code	O _M	The status code of the associated MM7_cancel.REQ.
Sequence Number	O _M	Record number.
Time Stamp	O _M	Time of generation of the CDR.
Record extensions	O _C	A set of network/manufacture specific extensions to the record.

6.1.5.11 MM7 Extended Replace record (MM7ER-CDR)

If enabled, an MM7 Extended Replace MM7ER-CDR shall be produced in the MMS R/S if and when the MMS R/S has sent an MM7_extended_replace.RES to the MMS VASP.

Table 6.1.5.11.1: MM7 Extended Replace record (MM7ER-CDR)

Field	Category	Description
Record Type	M	MM7 Extended Replace record
Recipient MMS Relay/Server Address	M	IP address or domain name of Recipient MMS R/S.
VASP ID	M	Identifier of the VASP for this MMS R/S
VAS ID	M	Identifier of the originating application.
Message ID	M	The MM identification provided by the Originator MMS R/S.
Service code	O _C	Charging related information that is used directly for billing purposes
Content type	M	The content type of the MM content.
Submission time	O _C	The time at which the MM was submitted from the VASP if specified in the MM7_replace_REQ.
Earliest Time Of Delivery	O _C	This field contains either the earliest time to deliver the MM or the number of seconds to wait before delivering the MM if specified by the VASP
Request Status Code	O _M	The status code of associated MM7_extended_replace.REQ.
Sequence Number	O _M	Record number
Time Stamp	O _M	Time of generation of the CDR.
Record extensions	O _C	A set of network/manufacture specific extensions to the record.

6.2 Data description for MMS online charging

6.2.1 Ro message contents

6.2.1.0 General

The MMS R/S generate Debit / Reserve Units information that can be transferred from the CTF to the OCF. For this purpose, MMS online charging utilises the *Debit Units and Reserve Units* procedure that is specified in the 3GPP Debit / Reserve Units operation in TS 32.299 [50].

The *Debit / Reserve Units* procedure employs the *Debit / Reserve Units Request* and *Debit / Reserve Units Response* messages.

Table 6.2.1.1 describes the use of these messages for MMS online charging.

Table 6.2.1.1: MMS online charging messages contents

Message	Source	Destination
Debit / Reserve Units Request	MMS R/S	OCS
Debit / Reserve Units Response	OCS	MMS R/S

This clause describes the different Information Elements (IE) used in the Debit / Reserve Units messages and the charging data configuration defined in clause 5.4 of TS 32.240 [1].

Note that not for all structured IEs the individual parameters are listed in the table. Detailed descriptions of the IEs are provided in TS 32.299 [50].

6.2.1.1 Debit / Reserve Units Request message

Table 6.2.1.1.1 illustrates the basic structure of a *Debit / Reserve Units Request* message from MMS R/S as used for MMS online charging.

Table 6.2.1.1.1: *Debit / Reserve Units Request* message contents for MMS

Information Element	Category	Description
Session Identifier	M	This field identifies the operation session.
Originator Host	M	This field contains the identification of the source point of the operation.
Originator Domain	M	This field contains the realm of the operation Originator.
Destination Domain	M	This field contains the realm of the operation destination.
Operation Identifier	M	This field is a unique operation identifier.
Operation Token	M	This field contains the service identifier.
Operation Type	M	This field defines the transfer type: event for event based charging and start, interim, stop for session based charging.
Operation Number	M	This field contains the sequence number of the transferred messages.
Destination Host	O _c	This field contains the identification of the destination point of the operation.
User Name	O _c	This field contains the identification of the user.
Origination State	-	Not used for MMS in 3GPP.
OriginationTimestamp	O _c	This field contains the time when the operation is requested.
Subscriber Identifier	O _M	This field contains the identification of the mobile subscriber (i.e. MSISDN) that uses the requested service.
Termination Cause	-	Not used for MMS in 3GPP.
Requested Action	O _c	This field contains the requested action.
Multiple Operation	O _M	This field indicate the occurrence of multiple operations.
Multiple Unit Operation	O _c	This field contains the parameter for the quota management.
Subscriber Equipment Number	-	Not used for MMS in 3GPP.
Proxy Information	O _c	This field contains the parameter of the proxy.
Route Information	O _c	This field contains the parameter of the route.
Service Information	O _M	This field holds the MMS specific parameter and is described in clause 6.3.

6.2.1.2 Debit / Reserve Units Response message

Table 6.2.1.2.1 illustrates the basic structure of a Debit / Reserve Units Response message as used for MMS charging. This message is always used by the OCS as specified below, independent of the receiving MMS R/S and the operation type that is being replied to.

Table 6.2.1.2.1: Debit / Reserve Units Response message contents for MMS

Information Element	Category	Description
Session Identifier	M	This field identifies the operation session.
Operation Result	M	This field identifies the result of the operation.
Originator Host	M	This field contains the identification of the source point of the operation.
Originator Domain	M	This field contains the realm of the operation Originator.
Operation Identifier	M	This field is a unique operation identifier.
Operation Type	M	This field defines the transfer type: event for event based charging and start, interim, stop for session based charging.
Operation Number	M	This field contains the sequence number of the transferred messages.
Operation Failover	-	Not used for MMS in 3GPP.
Multiple Unit Operation	O _c	This field contains the parameter for the quota management.
Operation Failure Action	O _c	This field defines the operation if a failure has occurred at the OCS for ECUR.
Operation Event Failure Action	O _c	This field defines the operation if a failure has occurred at the OCS for IEC.
Redirection Host	-	Not used for MMS in 3GPP.
Redirection Host Usage	-	Not used for MMS in 3GPP.
Redirection Cache Time	-	Not used for MMS in 3GPP.
Proxy Information	O _c	This field contains the parameter of the proxy.
Route Information	O _c	This field contains the parameter of the route.
Failed parameter	O _c	This field contains missing and/or unsupported parameter that caused the failure.
Service Information	-	Not used for MMS in 3GPP.

6.2a Data description for MMS converged charging

6.2a.1 Message contents

6.2a.1.1 General

The Charging Data Request and Charging Data Response are specified in TS 32.290 [2] and include charging information. The Charging Data Request can be of type [Event, Initial, Termination].

Table 6.2a.1.1.1 describes the use of these messages for converged charging.

Table 6.2a.1.1.1: Converged charging messages reference table

Message	Source	Destination
Charging Data Request	MMS Node	CHF
Charging Data Response	CHF	MMS Node

The following clauses describe the different fields used in the Charging Data messages and the category in the tables is used according to the charging data configuration defined in clause 5.4 of TS 32.240 [1].

6.2a.1.2 Structure for the converged charging message formats

6.2a.1.2.1 Charging Data Request message

Table 6.2a.1.2.1.1 illustrates the basic structure of a Charging Data Request message as used for MMS converged charging.

Table 6.2a.1.2.1.1: Charging Data Request message contents

Information Element	Category	Description
Session Identifier	O _C	Described in TS 32.290 [2]
Subscriber Identifier	O _M	Described in TS 32.290 [2]
NF Consumer Identification	M	Described in TS 32.290 [2]
Charging Identifier	O _M	Described in TS 32.290 [2]
Invocation Timestamp	M	Described in TS 32.290 [2]
Invocation Sequence Number	M	Described in TS 32.290 [2]
Retransmission Indicator	-	This field is not applicable.
One-time Event	O _C	Described in TS 32.290 [2]
One-time Event Type	O _C	Described in TS 32.290 [2]
Notify URI	-	This field is not applicable.
Supported Features	O _C	Described in TS 32.290 [2]
Service Specification Information	O _C	Described in TS 32.290 [2]
Triggers	-	This field is not applicable.
Multiple Unit Usage	O _C	This field is present when the number of units is beyond one (i.e., more than one MMS)
Rating Group	M	Described in TS 32.290 [2]
Requested Unit	O _C	Described in TS 32.290 [2]
Time	-	This field is not applicable.
Total Volume	-	This field is not applicable.
Uplink Volume	-	This field is not applicable.
Downlink Volume	-	This field is not applicable.
Service Specific Units	O _C	This field is present when the number of units is beyond one (i.e., more than one MMS)
Used Unit Container	O _C	This field holds MMS charging information when more than one MMS. It may have multiple occurrences.
Service Identifier	O _C	Described in TS 32.290 [2]
Quota management Indicator	O _C	Described in TS 32.290 [2]
Triggers	-	This field is not applicable.
Trigger Timestamp	-	This field is not applicable.
Time	-	This field is not applicable.
Total Volume	O _C	Described in TS 32.290 [2]
Uplink Volume	-	This field is not applicable.
Downlink Volume	-	This field is not applicable.
Service Specific Unit	O _C	Described in TS 32.290 [2]
Event Time Stamps	O _C	Described in TS 32.290 [2]
Local Sequence Number	O _M	Described in TS 32.290 [2]
MMS Charging Information	O _M	This field holds the MMS specific information described in clause 6.4.2

6.2a.1.2.2 Charging Data Response message

Table 6.2a.1.2.2.1 illustrates the basic structure of a Charging Data Response message as used for MMS converged charging.

Table 6.2a.1.2.2.1: Charging Data Response Message Contents

Information Element	Category	Description
Session Identifier	O _C	Described in TS 32.290 [2]
Invocation Timestamp	M	Described in TS 32.290 [2]
Invocation Result	O _C	Described in TS 32.290 [2]
Invocation Sequence Number	M	Described in TS 32.290 [2]
Session Failover	O _C	Described in TS 32.290 [2]
Supported Features	O _C	Described in TS 32.290 [2]
Triggers	-	This field is not applicable.
Multiple Unit information	O _C	This field is applicable for ECUR.
Result Code	O _C	Described in TS 32.290 [2]
Rating Group	O _M	Described in TS 32.290 [2]
Granted Unit	O _C	Described in TS 32.290 [2]
Tariff Time Change	-	This field is not applicable.
Time	-	This field is not applicable.
Total Volume	-	This field is not applicable.
Uplink Volume	-	This field is not applicable.
Downlink Volume	-	This field is not applicable.
Service Specific Units	O _C	This field is present when the number of units is beyond one (i.e., more than one MMS)
Validity Time	O _C	Described in TS 32.290 [2]
Final Unit Indication	-	This field is not applicable.
Time Quota Threshold	-	This field is not applicable.
Volume Quota Threshold	-	This field is not applicable.
Unit Quota Threshold	-	This field is not applicable.
Quota Holding Time	-	This field is not applicable.
Triggers	-	This field is not applicable.

6.3 MMS charging specific parameters

6.3.0 General

The MMS Information parameter used for MMS charging is provided in the Service Information parameter.

6.3.1 MMS charging information assignment for Service Information

The components in the Service Information that are use for MMS charging can be found in table 6.3.1.1.

Table 6.3.1.1: Service Information used for MMS charging

Information Element	Category	Description
Service Information	O _M	This is a structured field and holds the 3GPP specific parameter as defined in TS 32.299 [50]. For MMS Charging the MMS-Information and PS-Information are used.
MMS Information	O _M	This is a structured field and holds the MMS specific parameters. The details are defined in table 6.3.2.
SMS Information	O _C	This is a structured field and holds PS specific parameters relevant to MMS. The complete structure is defined in TS 32.274 [34].
Originator SCCP Address	O _C	This field holds the SCCP calling address used to receive the MMS.
Recipient Info	O _C	This field holds recipient information for the MMS. It occurs at most one time in the MMS delivery case.
PS Information	O _C	This is a structured field and holds PS specific parameters relevant to MMS. The complete structure is defined in TS 32.251 [11].
3GPP User Location Info	O _C	This field holds the information about the location of the subscriber during the MMS transaction. Only applicable to online charging.
3GPP RAT Type	O _C	This field holds information about the radio access technology used for the MMS transaction.
PDP Address	O _C	This field holds the IP address used by the subscriber for the MMS transaction.
MS Time Zone	O _C	This field indicates the offset between universal time and local time in steps of 15 minutes of where the MS currently resides.

6.3.2 Definition of the MMS Information

MMS specific charging information is provided within the MMS Information. The detailed structure of the MMS Information parameter can be found in table 6.3.2.1.

Table 6.3.2.1: Structure of the MMS Information

Information Element	Category	Description
Originator Address	O _C	This field holds the address (Public User ID: SIP URL, E.164, etc.) of the party generating the MMS.
Recipient Address	O _C	This field holds the address (Public User ID: SIP URL, E.164, etc.) of the party to whom the MMS is sent.
Correlation Information	O _M	Bearer correlation information
Submission Time	O _C	The time at which the MM was submitted or forwarded as specified in the corresponding MM1 message.
MM Content Type	O _C	The content type of the MM content.
Priority	O _C	The priority (importance) of the message if specified by the originator MMS User Agent.
Message ID	O _C	This field holds the MM identification provided by the Originator MMS R/S.
Message Type	O _C	This field holds the type of the message according to the MMS transactions e.g. submission, delivery.
Message Size	O _C	This field holds the total size of the MMS.
Message Class	O _C	The class of the MM (e.g., personal, advertisement, information service) if specified by the originator MMS User Agent.
Delivery Report Requested	O _C	This field indicates whether a delivery report has been requested by the originator MMS User Agent or not.
Read Reply Report Requested	O _C	A request for read-reply report as specified in the MM1 message.
MMBox Storage Requested	O _C	This parameter is only present if the MMBox feature is supported by the MMS R/S and storage of the MM was requested by originator MMS User Agent (i.e., of the MMS User Agent that has sent the MM1_submit.REQ).
Applic ID	O _C	This field holds the identification of the destination application that the underlying MMS abstract message was addressed to.
Reply Applic ID	O _C	This field holds the identifier of a "reply path", i.e. the identifier of the application to which delivery reports, read-reply reports and reply-MMs are addressed.
Aux Applic Info	O _C	This field holds additional application/implementation specific control information.
Content Class	O _C	This field classifies the content of the MM to the smallest content class to which the MM belongs
DRM Content	O _C	This field indicates if the MM contains DRM-protected content.
Adaptations	O _C	This field indicates if the Originator allows adaptation of the content (default True).
VAS Identifier	O _C	This field indicates the VAS that originated the MM. Only present in MM1 Retrieval and if the MM was received over an MM7 interface.
VASP Identifier	O _C	This field indicates the VASP that originated the MM. Only present in MM1 Retrieval and if the MM was received over an MM7 interface.

6.3.3 Detailed message format for online charging

Editor's note: TBD.

6.3.4 Formal MMS charging parameter description

6.3.4.1 MMS charging information for CDRs

The detailed definitions, abstract syntax and encoding of the MMS CDR parameters are specified in TS 32.298 [51].

6.3.4.2 MMS charging information for charging events

The detailed charging event parameter definitions are specified in TS 32.299 [50].

6.4 Definition of the MMS converged charging information

6.4.1 General

The Charging Information parameter used for MMS converged charging is provided in the following clauses.

6.4.2 Definition of MMS charging information

MMS specific charging information used for MMS converged charging is provided within the MMS charging Information.

Table 6.4.2.1: Structure of MMS Charging information

Information Element	Category	Description
Originator Info	O _M	This field is a grouped field and holds information on originator of the MMS
Originator SUPI	O _M	This field holds the SUPI of the originator of the MMS. This field is present if different from subscriber identifier field.
Originator GPSI	O _C	This field holds the GPSI of the originator of the MMS.
Originator Other Address	O _M	This field holds the address of the originator of the MMS, when different from SUPI and GPSI e.g., email, short code. This field may have multiple occurrences.
Recipient Info	O _C	This field holds recipient information for the MMS. It occurs at most one time in the MMS delivery case.
Recipient SUPI	O _M	This field holds the SUPI of the recipient of the MMS. This field is present if different from subscriber identifier field.
Recipient GPSI	O _C	This field holds the GPSI of the recipient of the MMS.
Recipient Other Address	O _C	This field holds the address of the recipient of the MMS, when different from SUPI and GPSI, if available e.g., email, short code. This field may have multiple occurrences
User Location Info	O _C	This field holds the information about the location of the subscriber during the MMS transaction.
UE Time Zone	O _C	This field indicates the offset between universal time and local time in steps of 15 minutes of where the UE currently resides.
RAT Type	O _C	This field holds information about the radio access technology used for the MMS transaction.
Submission Time	O _C	The time at which the MM was submitted or forwarded as specified in the corresponding MM1 message.
MM Content Type	O _C	The content type of the MM content.
Priority	O _C	The priority (importance) of the message if specified by the originator MMS User Agent.
Message ID	O _C	This field holds the MM identification provided by the Originator MMS Node.
Message Type	O _C	This field holds the type of the message according to the MMS transactions e.g., submission, delivery.
Message Size	O _C	This field holds the total size of the MMS.
Message Class	O _C	The class of the MM (e.g., personal, advertisement, information service) if specified by the originator MMS User Agent.
Delivery Report Requested	O _C	This field indicates whether a delivery report has been requested by the originator MMS User Agent or not.
Read Reply Report Requested	O _C	A request for read-reply report as specified in the MM1 message.
Applic ID	O _C	This field holds the identification of the destination application that the underlying MMS abstract message was addressed to.
Reply Applic ID	O _C	This field holds the identifier of a "reply path" i.e., the identifier of the application to which delivery reports, read-reply reports and reply-MMs are addressed.
Aux Applic Info	O _C	This field holds additional application/implementation specific control information.
Content Class	O _C	This field classifies the content of the MM to the smallest content class to which the MM belongs
DRM Content	O _C	This field indicates if the MM contains DRM-protected content.
Adaptations	O _C	This field indicates if the Originator allows adaptation of the content (default True).
VAS Identifier	O _C	This field indicates the VAS that originated the MM. Only present in MM1 Retrieval and if the MM was received over an MM7 interface.
VASP Identifier	O _C	This field indicates the VASP that originated the MM. Only present in MM1 Retrieval and if the MM was received over an MM7 interface.

6.4.3 Detailed message format for converged charging

The following clause specifies per Operation Type the charging data that are sent by MMS Node for MMS converged charging.

The Operation Types are listed in the following order: I (Initial)/T (Termination)/E (Event). Therefore, when all Operation Types are possible it is marked as ITE. If only some Operation Types are allowed for a node, only the appropriate letters are used (i.e., IT or E) as indicated in the table heading. The omission of an Operation Type for a particular field is marked with "-" (i.e., I-E). Also, when an entire field is not allowed in a node the entire cell is marked as "-".

Table 6.4.3.1 defines the basic structure of the supported fields in the *Charging Data Request* message for MMS converged charging.

Table 6.4.3.1: Supported fields in *Charging Data Request* message

Information Element	Node Type	MMS Node
	Supported Operation Types	ITE
Session Identifier		ITE
Subscriber Identifier		ITE
NF Consumer Identification		ITE
Charging Identifier		ITE
Invocation Timestamp		ITE
Invocation Sequence Number		ITE
Retransmission Indicator		-
One-time Event		--E
One-time Event Type		--E
Notify URI		-
Supported Features		I-E
Service Specification Information		ITE
Triggers		-
Multiple Unit Usage		ITE
MMS Charging Information		
Originator Info		ITE
Recipient Info		ITE
User Location Info		ITE
UE Time Zone		ITE
RAT Type		ITE
Submission Time		ITE
MM Content Type		ITE
Priority		ITE
Message ID		ITE
Message Type		ITE
Message Size		ITE
Message Class		ITE
Delivery Report Requested		ITE
Read Reply Report Requested		ITE
Applic ID		ITE
Reply Applic ID		ITE
Aux Applic Info		ITE
Content Class		ITE
DRM Content		ITE
Adaptations		ITE
VAS Identifier		ITE
VASP Identifier		ITE

Table 6.4.3.2 defines the basic structure of the supported fields in the *Charging Data Response* message for MMS converged charging.

Table 6.4.3.2: Supported fields in *Charging Data Response* message

Information Element	Node Type	MMS Node
	Supported Operation Types	ITE
Session Identifier		ITE
Invocation Timestamp		ITE
Invocation Result		ITE
Invocation Sequence Number		ITE
Session Failover		I--
Triggers		-
Multiple Unit information		I-E
Result Code		I--
Rating Group		I--
Granted Unit		I--
Validity Time		I--
Final Unit Indication		-
Time Quota Threshold		-
Volume Quota Threshold		-
Unit Quota Threshold		-
Quota Holding Time		-
Triggers		-

6.4.4 Formal MMS converged charging parameter description

6.4.4.1 MMS charging CHF CDR parameters

The detailed definitions, abstract syntax and encoding of the MMS charging CHF CDR parameters are specified in TS 32.298 [51].

6.4.4.2 MMS charging resources attributes

The detailed definitions of resources attributes used for MMS charging are specified in TS 32.291 [3].

6.5 Bindings for MMS converged charging

This mapping between the Information Elements, resource attributes and CHF CDR parameters for MMS converged charging is described in clause 7 of TS 32.291 [3].

Annex A (informative): Bibliography

This Annex is a placeholder for documents which are not explicitly cited in the present document.

Annex B (informative): Change history

Change history								
Date	TSG #	TSG Doc.	CR	Rev	Subject/Comment	Cat	Old	New
Sep 2003	SA_21	SP-030412	--	--	Submitted to TSG SA#21 for Information	--	1.0.0	
Sep 2004	SA_25	SP-040555	--	--	Submitted to TSG SA#25 for Approval	--	2.0.0	6.0.0
Dec 2004	SA_26	SP-040780	0001	--	Introduce Application Data in MMS Charging – Align with T2's TS 23.140 (MMS6)	F	6.0.0	6.1.0
Dec 2004	SA_26	SP-040780	0002	--	Introduce Content Adaptation in MMS Charging – Align with T2's 23.140 (MMS6)	F	6.0.0	6.1.0
Dec 2004	SA_26	SP-040780	0003	--	Correction on VASP MMS CDR triggers	F	6.0.0	6.1.0
Mar 2005	SA_27	SP-050031	0004	--	Align MM10 charging functionality with T2's TS 23.140	F	6.1.0	6.2.0
Mar 2005	SA_27	SP-050031	0005	--	Charge MMS VASP for getting Terminal Capabilities information - Align with T2's TS 23.140	F	6.1.0	6.2.0
Mar 2005	SA_27	SP-050031	0006	--	Correct condition for generating a MM Deletion CDR - Align with T2's TS 23.140	F	6.1.0	6.2.0
Mar 2005	SA_27	SP-050031	0007	--	Extension of the charging functionality for MM cancellation and replacement Align with T2's TS 23.140	F	6.1.0	6.2.0
Jun 2005	SA_28	SP-050277	0008	--	Correction to scope	F	6.2.0	6.3.0
Jun 2005	SA_28	SP-050277	0009	--	Correction to references	F	6.2.0	6.3.0
Jun 2005	SA_28	SP-050277	0010	--	Corrections and alignments	F	6.2.0	6.3.0
Sep 2005	SA_29	SP-050440	0011	--	Correct use of Content Type information	F	6.3.0	6.4.0
Sep 2005	SA_29	SP-050440	0012	--	Correct MMS triggers for offline charging	F	6.3.0	6.4.0
Sep 2005	SA_29	SP-050440	0013	--	Correct VASP MMS Recipient Charging – Align with TS 22.140	F	6.3.0	6.4.0
Dec 2005	SA_30	SP-050701	0014	--	Align with 32.299: remove CC-Subsession-Id, CC-Correlation-Id, User-Name and Acct-Multi-Session-Id from the relevant parts of the CCR and CCA messages	F	6.4.0	6.5.0
Dec 2005	SA_30	SP-050701	0016	--	Use of User location information and RAT type in MMS charging - Align with 22.140 requirements	F	6.4.0	6.5.0
Mar 2006	SA_31	SP-060085	0017	--	Correct the use of Immediate Event Charging (IEC) as an online charging principle for MMS - Align with 32.299	F	6.5.0	6.6.0
Jun 2007	SA_36	SP-070273	0018	--	Correction to failure handling procedures for online charging	F	6.6.0	7.0.0
Sep 2007	SA_37	SP-070605	0020	--	Correction on MMBox charging - Align with 32.299	A	7.0.0	7.1.0
Dec 2008	SA_42	SP-080841	0021	--	Correction on Multiple Unit Operation category	F	7.1.0	7.2.0
Dec 2008	SA_42	--	--	--	Upgrade to Release 8	--	7.0.0	8.0.0
Dec 2009	-	-	-	-	Update to Rel-9 version (MCC)	-	8.0.0	9.0.0
Oct 2010	SA_49	SP-100497	0022	--	Correction on MMS Online Charging principles	D	9.0.0	9.1.0
Mar 2011	SA_51	SP-110109	0023	1	Add E.164 harmonized address format to the current E.212 in MMS Charging	F	9.1.0	10.0.0
Sep 2011	--	--	--	--	Correction of CR history (9.2.0 instead of 10.0.0)	--	10.0.0	10.0.1
Sep 2012	SA_57	SP-120575	0024	1	Addition of MS Timezone for NetLo	B	10.0.1	11.0.0
2014-07	-	-	-	-	Rapporteur/MCC: General editorial changes and clean-up.	-	11.0.0	11.0.1
2014-09	SA_65	SP-140564	0027	1	Corrections for alignment between charging specifications	F	11.0.1	12.0.0
2014-12	SA_66	SP-140804	0028	-	Additional corrections for removal of I-WLAN solution	F	12.0.0	12.1.0
		SP-140805	0029	-	Corrections on definition for parameter category	F		
2016-01					Upgrade to Rel-13 (MCC)		12.1.0	13.0.0

Change history							
Date	Meeting	TDoc	CR	Rev	Cat	Subject/Comment	New version
2017-03	SA#75	SP-170138	0031	1	C	Remove reference to RFC 3588	14.0.0
2018-06	-	-	-	-	-	Update to Rel-15 version (MCC)	15.0.0
2020-07	-	-	-	-	-	Update to Rel-16 version (MCC)	16.0.0
2022-03	-	-	-	-	-	Update to Rel-17 version (MCC)	17.0.0
2022-09	SA#97e	SP-220866	0032	1	B	Addition of converged charging architecture	18.0.0
2022-09	SA#97e	SP-220866	0033	1	B	Addition of converged charging scenarios	18.0.0
2022-09	SA#97e	SP-220866	0034	1	B	Addition of converged charging information	18.0.0
2023-09	SA#101	SP-230969	0035	1	B	Add reference point between MMS node and CHF	18.1.0
2024-03	SA#103	SP-240173	0036	-	F	Rel-18 CR 32.270 Correction of MMS reference and cleanup	18.2.0

History

Document history		
V18.2.0	May 2024	Publication