

ETSI TS 132 280 V18.0.0 (2024-05)



**Universal Mobile Telecommunications System (UMTS);
LTE;
Telecommunication management;
Charging management;
Advice of Charge (AoC) service
(3GPP TS 32.280 version 18.0.0 Release 18)**



Reference

RTS/TSGS-0532280vi00

Keywords

LTE,UMTS

ETSI

650 Route des Lucioles
F-06921 Sophia Antipolis Cedex - FRANCE

Tel.: +33 4 92 94 42 00 Fax: +33 4 93 65 47 16

Siret N° 348 623 562 00017 - APE 7112B
Association à but non lucratif enregistrée à la
Sous-Préfecture de Grasse (06) N° w061004871

Important notice

The present document can be downloaded from:

<https://www.etsi.org/standards-search>

The present document may be made available in electronic versions and/or in print. The content of any electronic and/or print versions of the present document shall not be modified without the prior written authorization of ETSI. In case of any existing or perceived difference in contents between such versions and/or in print, the prevailing version of an ETSI deliverable is the one made publicly available in PDF format at www.etsi.org/deliver.

Users of the present document should be aware that the document may be subject to revision or change of status.

Information on the current status of this and other ETSI documents is available at

<https://portal.etsi.org/TB/ETSIDeliverableStatus.aspx>

If you find errors in the present document, please send your comment to one of the following services:

<https://portal.etsi.org/People/CommitteeSupportStaff.aspx>

If you find a security vulnerability in the present document, please report it through our
Coordinated Vulnerability Disclosure Program:

<https://www.etsi.org/standards/coordinated-vulnerability-disclosure>

Notice of disclaimer & limitation of liability

The information provided in the present deliverable is directed solely to professionals who have the appropriate degree of experience to understand and interpret its content in accordance with generally accepted engineering or other professional standard and applicable regulations.

No recommendation as to products and services or vendors is made or should be implied.

No representation or warranty is made that this deliverable is technically accurate or sufficient or conforms to any law and/or governmental rule and/or regulation and further, no representation or warranty is made of merchantability or fitness for any particular purpose or against infringement of intellectual property rights.

In no event shall ETSI be held liable for loss of profits or any other incidental or consequential damages.

Any software contained in this deliverable is provided "AS IS" with no warranties, express or implied, including but not limited to, the warranties of merchantability, fitness for a particular purpose and non-infringement of intellectual property rights and ETSI shall not be held liable in any event for any damages whatsoever (including, without limitation, damages for loss of profits, business interruption, loss of information, or any other pecuniary loss) arising out of or related to the use of or inability to use the software.

Copyright Notification

No part may be reproduced or utilized in any form or by any means, electronic or mechanical, including photocopying and microfilm except as authorized by written permission of ETSI.

The content of the PDF version shall not be modified without the written authorization of ETSI.

The copyright and the foregoing restriction extend to reproduction in all media.

© ETSI 2024.
All rights reserved.

Intellectual Property Rights

Essential patents

IPRs essential or potentially essential to normative deliverables may have been declared to ETSI. The declarations pertaining to these essential IPRs, if any, are publicly available for **ETSI members and non-members**, and can be found in ETSI SR 000 314: "*Intellectual Property Rights (IPRs); Essential, or potentially Essential, IPRs notified to ETSI in respect of ETSI standards*", which is available from the ETSI Secretariat. Latest updates are available on the ETSI Web server (<https://ipr.etsi.org/>).

Pursuant to the ETSI Directives including the ETSI IPR Policy, no investigation regarding the essentiality of IPRs, including IPR searches, has been carried out by ETSI. No guarantee can be given as to the existence of other IPRs not referenced in ETSI SR 000 314 (or the updates on the ETSI Web server) which are, or may be, or may become, essential to the present document.

Trademarks

The present document may include trademarks and/or tradenames which are asserted and/or registered by their owners. ETSI claims no ownership of these except for any which are indicated as being the property of ETSI, and conveys no right to use or reproduce any trademark and/or tradename. Mention of those trademarks in the present document does not constitute an endorsement by ETSI of products, services or organizations associated with those trademarks.

DECT™, **PLUGTESTS™**, **UMTS™** and the ETSI logo are trademarks of ETSI registered for the benefit of its Members. **3GPP™** and **LTE™** are trademarks of ETSI registered for the benefit of its Members and of the 3GPP Organizational Partners. **oneM2M™** logo is a trademark of ETSI registered for the benefit of its Members and of the oneM2M Partners. **GSM®** and the GSM logo are trademarks registered and owned by the GSM Association.

Legal Notice

This Technical Specification (TS) has been produced by ETSI 3rd Generation Partnership Project (3GPP).

The present document may refer to technical specifications or reports using their 3GPP identities. These shall be interpreted as being references to the corresponding ETSI deliverables.

The cross reference between 3GPP and ETSI identities can be found under <https://webapp.etsi.org/key/queryform.asp>.

Modal verbs terminology

In the present document "**shall**", "**shall not**", "**should**", "**should not**", "**may**", "**need not**", "**will**", "**will not**", "**can**" and "**cannot**" are to be interpreted as described in clause 3.2 of the [ETSI Drafting Rules](#) (Verbal forms for the expression of provisions).

"**must**" and "**must not**" are **NOT** allowed in ETSI deliverables except when used in direct citation.

Contents

Intellectual Property Rights	2
Legal Notice	2
Modal verbs terminology.....	2
Foreword.....	5
1 Scope	6
2 References	7
3 Definitions, symbols and abbreviations	8
3.1 Definitions	8
3.2 Symbols.....	9
3.3 Abbreviations	9
4 Architecture considerations	10
4.1 High level AoC aspects	10
4.2 AoC in GSM network architecture	10
4.3 AoC in IP Multimedia Subsystem (IMS) architecture	11
4.3.0 Introduction.....	11
4.3.1 AoC functional entities	12
4.3.1.1 AoC Function	12
4.3.2 AoC interfaces	13
4.3.3 AoC interworking with other features	14
4.3.3.1 AoC and offline charging	14
4.3.3.1.1 Interworking for AoC service execution	14
4.3.3.1.2 AoC invocation recording	14
4.3.3.2 AoC and online charging	14
4.3.3.3 AoC and RTTI	14
5 AoC principles and flows	15
5.1 Common charge advice principles	15
5.2 AoC in GSM networks (CAI description).....	15
5.3 AoC in IMS	15
5.3.1 Basic principles and definitions	15
5.3.2 Message flows and types for offline charging	15
5.3.2.0 Introduction.....	15
5.3.2.1 Successful session establishment: AoC-S with AoC Information in reliable 1xx response (originating side)	16
5.3.2.2 Mid-session procedure: AoC-S with AoC Information in an SIP INFO request	18
5.3.2.3 Session release: AoC-E – originating party clears	19
5.3.2.4 Session release: AoC-E – terminating party clears	21
5.3.2.5 AoC Function co-located with same AS providing the service.....	23
5.3.2.5.0 Introduction	23
5.3.2.5.1 Successful session establishment: AoC-S (originating side)	23
5.3.2.5.2 AOC-D for serving party in SIP INFO request	26
5.3.2.5.3 Session release: AoC-E – serving party clears	27
5.4 AoC in Inter-connected	29
5.4.1 Principles	29
5.4.2 Scenarios.....	29
5.4.3 Message flows	29
5.5 AoC support for PSTN/ISDN Emulation	29
6 Definition of AoC Information.....	30
6.0 General	30
6.1 AoC Information model principles.....	30
6.2 AoC Information model	30
6.3 AoC data definition	32
6.3.1 Ro message contents	32

6.3.1.1	Summary of AoC message formats.....	32
6.3.1.2	Structure for the Debit / Reserve Units message formats.....	32
6.3.1.2.0	General	32
6.3.1.2.1	Debit / Reserve Units Request message	32
6.3.1.2.2	Debit / Reserve Units Response message.....	33
6.3.1.3	Rf message content related to AoC service.....	33
6.3.1.3.0	Introduction	33
6.3.1.3.1	Charging Data Request message	34
6.3.1.3.2	Charging Data Response message	34
6.3.2	Definition of Service Information.....	34
6.3.3	Definition of AoC Information	35
6.3.3.0	General	35
6.3.3.1	AoC Information assignment for Service Information.....	35
6.3.3.2	Definition of the Tariff Information.....	35
6.3.3.3	Definition of AoC Cost Information	36
6.4	AoC subscription and formatting parameters	37
Annex A (informative): AoC use cases		38
A.0	General	38
A.1	Call scenarios with AoC Information provided at the beginning and/or during and/or at the end of the call	38
A.1.1	Outgoing call with Tariff provided by the charging domain at the start of the call.....	38
A.1.2	Outgoing call with Tariff provided by a remote network (PSTN or IMS) or a 3 rd party service provider (AS) at the start of the call.....	38
A.1.3	Outgoing call with Tariff provided by the charging domain in addition to an add-on charge received from the remote network (PSTN or IMS) or from a 3 rd party service provider (AS)	39
A.1.4	Outgoing call with Tariff change provided by the charging domain during an on-going call.....	39
A.1.5	Outgoing call with regular Cost updates provided by the charging domain during an on-going call.....	40
A.1.6	Outgoing call with Cost summary provided at the end of the call.....	40
A.1.7	Incoming call with Tariff provided by the charging domain at the start of the call	40
Annex B (informative): Message flow for basic IMS session establishment and interaction with online charging		41
Annex C (informative): AoC Information mapping.....		44
C.0	General	44
C.1	AoC Information mapping to CAI element.....	44
C.2	AoC Information mapping to charging Information Elements	45
C.3	AoC Information mapping to NNI charging information	46
Annex D (informative): Bibliography		47
Annex E (informative): Change history		49
History		50

Foreword

This Technical Specification has been produced by the 3rd Generation Partnership Project (3GPP).

The contents of the present document are subject to continuing work within the TSG and may change following formal TSG approval. Should the TSG modify the contents of the present document, it will be re-released by the TSG with an identifying change of release date and an increase in version number as follows:

Version x.y.z

where:

- x the first digit:
 - 1 presented to TSG for information;
 - 2 presented to TSG for approval;
 - 3 or greater indicates TSG approved document under change control.
- y the second digit is incremented for all changes of substance, i.e. technical enhancements, corrections, updates, etc.
- z the third digit is incremented when editorial only changes have been incorporated in the document.

1 Scope

The present document specifies the Advice of Charge (AoC) framework for relevant events, sessions, and services. The 3GPP umbrella charging architecture and principles are defined in TS 32.240 [1].

The AoC framework detailed herein provides for both offline and online charging models. It specifies the following:

- The AoC architecture.
- The common principles that govern AoC.
- The AoC function that enables the IMS AoC framework.
- Exemplary message flows.
- AoC interface data description.

All terms, definitions and abbreviations used in the present document, that are common across 3GPP TSs, are defined in the 3GPP Vocabulary, TR 21.905 [100]. Those that are common across charging management in 3GPP network, services or subsystems are provided in the umbrella document TS 32.240 [1] and may be copied into clause 3 of the present document for ease of reading. Finally, those items that are specific to the present document are defined exclusively in the present document.

Requirements that govern the AoC work are specified in TS 22.115 [101].

2 References

The following documents contain provisions which, through reference in this text, constitute provisions of the present document.

- References are either specific (identified by date of publication, edition number, version number, etc.) or non-specific.
- For a specific reference, subsequent revisions do not apply.
- For a non-specific reference, the latest version applies. In the case of a reference to a 3GPP document (including a GSM document), a non-specific reference implicitly refers to the latest version of that document *in the same Release as the present document*.

- [1] 3GPP TS 32.240: "Telecommunication management; Charging management; Charging Architecture and Principles".
- [2] – [19] Void
- [20] 3GPP TS 32.260: "Telecommunication management; Charging management; IP Multimedia Subsystem (IMS) charging".
- [21] – [49] Void
- [50] 3GPP TS 32.299: "Telecommunication management; Charging management; Diameter charging application".
- [51] - [99] Void
- [100] 3GPP TR 21.905: "Vocabulary for 3GPP Specifications".
- [101] 3GPP TS 22.115: "Service aspects; Charging and billing".
- [102] - [201] Void.
- [202] 3GPP TS 22.173: "IP Multimedia Core Network Subsystem (IMS) Multimedia Telephony Service and supplementary services; Stage 1".
- [203] 3GPP TS 22.024: "Description of Charge Advice Information (CAI)".
- [204] 3GPP TS 22.086: "Advice of Charge (AoC) supplementary services; Stage 1".
- [205] 3GPP TS 23.086: "Advice of Charge (AoC) supplementary services; Stage 2".
- [206] 3GPP TS 24.086: "Advice of Charge (AoC) supplementary services; Stage 3".
- [207] 3GPP TS 23.078: "Customised Applications for Mobile network Enhanced Logic (CAMEL) Phase 4; Stage 2".
- [208] 3GPP TS 24.647: "Advice Of Charge (AOC) using IP Multimedia (IM) Core; Network (CN) subsystem".
- [209] 3GPP TS 29.658: "SIP Transfer of IP Multimedia Service Tariff Information; Protocol specification".
- [210] 3GPP TS 24.229: "IP multimedia call control protocol based on Session Initiation Protocol (SIP) and Session Description Protocol (SDP); Stage 3".
- [211] 3GPP TS 29.364: "IP Multimedia Subsystem (IMS) Application Server (AS) service data descriptions for AS interoperability".
- [212] ETSI TS 182 012 (V2.1.4): "Telecommunications and Internet converged Services and Protocols for Advanced Networking (TISPAN); IMS-based PSTN/ISDN Emulation Sub-system (PES); Functional architecture".

- [213] ETSI TS 183 043 (V2.3.1): "Telecommunications and Internet converged Services and Protocols for Advanced Networking (TISPAN); IMS-based PSTN/ISDN Emulation; Stage 3 specification".
- [214] ETSI ES 201 296 (V1.3.1): "Integrated Services Digital Network (ISDN); Signalling System No.7 (SS7); ISDN User Part (ISUP); Signalling aspects of charging".
- [215] 3GPP TS 22.078: "Customised Applications for Mobile network Enhanced Logic (CAMEL); Service description; Stage 1".
- [215] - [299] Void.
- [300] - [399] Void.
- [400] IETF RFC 2486 (1999): "The Network Access Identifier".

3 Definitions, symbols and abbreviations

3.1 Definitions

For the purposes of the present document, the terms and definitions given in TR 21.905 [100] and the following apply. A term defined in the present document takes precedence over the definition of the same term, if any, in TR 21.905 [100].

Add-on charge: additional charge on top of the current tariff. An add-on charge can either be metered in non-monetary units (e.g. meter pulse) or in monetary-units (e.g. currency).

Advice of Charge (AoC): The Advice of Charge (AoC) supplementary service provides AoC Information to the served user for information (AoCI) or for charging (AoCC) related to a corresponding event, session or usage of a service. The AoC service may be delivered prior to, during or after the service delivery.

AoC for Information (AoCI): An AoC supplementary service where the provided information is non-binding. I.e. the provided information is an estimation of the service cost and/or tariff. The provided information and the actual charges may differ.

AoC for Charging (AoCC): An AoC supplementary service where the provided information is binding. I.e. the provided information shall correspond to the actual charges.

AoC at communication set-up time (AOC-S): An AoC supplementary service provided at communication establishment and/or at tariff switch time. The provided information includes Tariff Information for the requested service.

AoC during the communication (AOC-D): An AoC supplementary service provided during the communication at predefined triggering conditions. The provided information includes accumulated Cost for the ongoing usage.

AoC at the end of communication (AOC-E): An AoC supplementary service provided when the communication is released. The provided information includes the total accumulated Cost.

Auxiliary Advice of Charge Function (AACF): An AACF provides Tariff and/or Cost information for the requested service. The AACF resides outside of the local AoC function and the charging domain.

NOTE: In this release, the AACF is considered as CDP for AoCI purpose. CDP is defined in TS 29.658 [209]. The terms AACF and CDP may change in the future as a result of possible addition of charging capabilities.

Charge Advice information (CAI): CAI elements as described in TS 22.024 [203].

Charge Determination Point (CDP): Defined in ETSI ES 201.296 [214].

IMS-based PSTN/ISDN Emulation Sub-system (PES): Defined in ETSI TS 182 012 [212].

Tariff: set of parameters defining the applied charges for the use of a particular bearer / session / service.

3.2 Symbols

For the purposes of the present document, the following symbols apply:

Symbol format

Bi	Reference point for the CDR file transfer from the IMS CGF to the BD.
ISC	ISC interface between the S-CSCF and the IMS-GWF
Rf	Offline Charging Reference Point between an IMS Network Entity or an AS and the CDF
Ro	Online Charging Reference Point between an AS, MRFC or the IMS-GWF and the OCS
<24.647>	Reference point between UE and P-CSCF as defined in TS 24.647 [208]
<29.658>	Reference point between IBCF/MGCF and the external network as defined in TS 29.658 [209]

3.3 Abbreviations

For the purposes of the present document, the abbreviations given in TR 21.905 [100] and the following apply.

An abbreviation defined in the present document takes precedence over the definition of the same abbreviation, if any, in TR 21.905 [100].

AACF	Auxiliary AoC Function
ACF	AoC Function
AGCF	Access Gateway Control Function
AoC	Advice of Charge
AoC-S	AoC at communication Set-up time
AoC-D	AoC During the communication
AoC-E	AoC at the End of the communication
AoCI	AoC for Information
AoCC	AoC for Charging
CAI	Charge Advice Information
CAMEL	Customised Applications for Mobile network Enhanced Logic
CCA	Credit-Control-Answer
CCF	Charging Collection Function
CCR	Credit-Control-Request
CDF	Charging Data Function
CDP	Charging Determination Point
CGF	Charging Gateway Function
CPC	Calling Party Category
CSCF	Call Session Control Function (I-Interrogating; P-Proxy; and S-Serving)
ECUR	Event Charging with Unit Reservation
HSS	Home Subscriber Server
IBCF	Interconnection Border Control Function
IEC	Immediate Event Charging
IMS-GWF	IMS Gateway Function
ISC	IMS Service Control
MGCF	Media Gateway Control Function
OCS	Online Charging System
OFCS	Offline Charging System
PES	IMS-based PSTN/ISDN Emulation Sub-system
RTTI	Realtime Transfer of Tariff Information
SCUR	Session Charging with Unit Reservation
SIP	Session Initiation Protocol
UE	User Equipment
UNI	User to Network Interface
VGW	Voice over IP Gateway

4 Architecture considerations

4.1 High level AoC aspects

Advice of Charge (AoC) is a user-specific supplementary service which provides AoC Information to the UE in real-time. It contains Cost and/or Tariff for the requested service, which may be provided either in monetary format (e.g. 0,10 €) or non-monetary format (e.g. 10 charging units).

Depending on the AoC service obligatory type (AoCI or AoCC), the provided information is either non-binding or binding. AoCI provides an estimation of the service Cost and/or Tariff which may deviate from the actual charges. In contrast to AoCI, AoCC is binding and shall correspond to the actual charges (e.g. corresponding bill position or amount which is deducted from the prepaid account).

The AoC service type depends on the following triggering events: AoC-S occurs at communication establishment and/or at tariff switch time. AoC-D is sent to the user during the communication, depending on predefined triggering conditions (e.g. to provide accumulated Cost for the ongoing usage every 5 seconds). AoC-E provides the total accumulated Cost of the service when the communication is released.

Any combination of the AoC service obligatory type and the service type may co-exist.

Online charging and offline charging and AoC services are mutually independent from the end user perspective.

The AoC Information may be based on Tariff Information from a local charging system, e.g. from an Online Charging System (OCS). Additionally, Tariff or Cost Information may be received from an external network or service provider in real time according to the Realtime Transfer of Tariff Information (RTTI) protocol defined in TS 29.658 [209]. This situation can occur in case of interconnection scenarios or 3rd party services like Service 0900. Depending on the local charging system indication, it may be decided whether external Tariff Information is either rejected or processed to create the AoC Information.

The selection of tariffs can be conditioned on any parameter defined in the charging information requirements mentioned in TS 22.115 [101]. The selection of tariffs may also be dependent upon and not limited to the Calling Party Category (CPC) defined in TS 24.229 [210], the user balances, consumed resource prior or within the session, discounts, benefits or any other commercial agreement that the user is engaged with the service provider.

AoC-related subscription status and user profiles are stored in the HSS. The AoC-related user profiles contain the following information:

- AoC service obligatory type (AoCI or AoCC);
- AoC service type (any combination of AoC-S, AoC-D, and AoC-E);
- AoC configuration and preferences.

Details are described in clause 6.4.

4.2 AoC in GSM network architecture

The CAMEL feature (Customised Applications for Mobile network Enhanced Logic) is described in TS 22.078 [215].

The Charge Advice Information (CAI) is described in TS 22.024 [203], TS 22.086 [204], TS 23.086 [205] and TS 24.086 [206].

4.3 AoC in IP Multimedia Subsystem (IMS) architecture

4.3.0 Introduction

The IMS Charging Architecture is described in TS 32.260 [20].

Figure 4.3.0.1 shows the specific part of the IMS charging architecture that handles AoC.

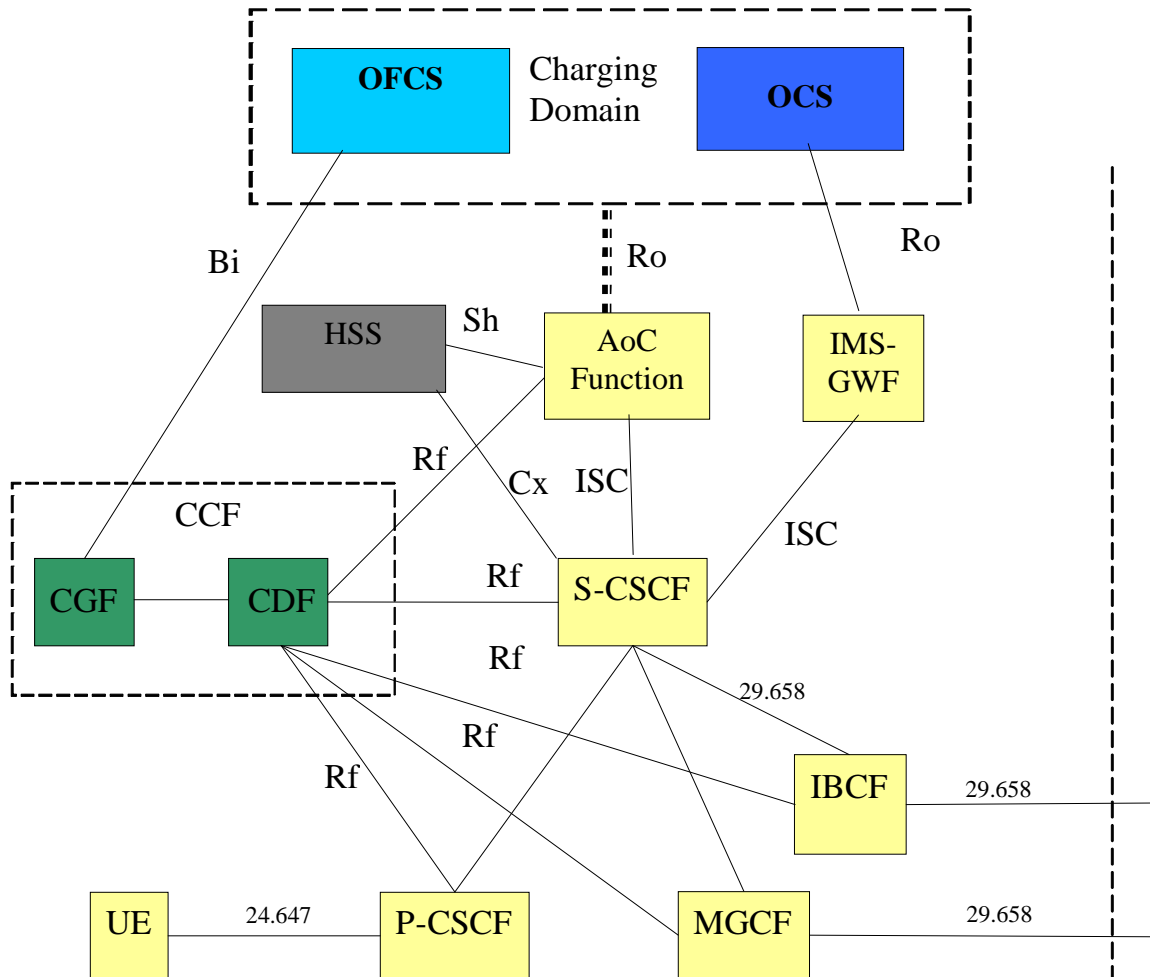

Figure 4.3.0.1: IMS AoC architecture

Figure 4.3.0.1 shows functional entities that are not directly involved in AoC, but completes the picture with affected interfaces.

TS 24.647 [208] specifies the AoC Information transferred to the UE via involved IMS functional entities.

TS 29.658 [209] specifies the procedures for the real-time transfer of charging information in interconnection scenarios.

AoC Function may reside in the same AS hosting the service for which the AoC Service is to be provided, or in a separate AS (not shown in figure 4.3.0.1).

The AoC Function (ACF) requests the AoC-related subscription and formatting parameters from the HSS via Sh. Additionally, filter criteria for ACF triggering may also be retrieved from the HSS by a CSCF via Cx.

The AoC Function obtains tariff information from the charging domain via Ro or the AoC function may have local Tariff information available (see clause 4.3.1.1). See the AoC interfaces for details.

NOTE: The AoC function may be unified with the IMS-GW function in online charging.

4.3.1 AoC functional entities

4.3.1.1 AoC Function

The AoC Function is a logical functional entity that provides AoC Information. It includes the following functions:

- Receive and or obtain Cost / Tariff data from various sources:
 - Charging domain
 - External tariff received from an AACF in real time (TS 29.658 [209])
 - Locally configured data (valid only for AoCI service)
- AoC data determination – reworks and arbitrates how to combine the incoming Tariff / Cost sources.

This shall be done through consultation with the charging domain in the AoCC service and can be done locally at the ACF for AoCI service

- Transform the AoC data into the corresponding output message format for presentation.

NOTE 1: In this release, the ACF is considered as CGP for AoCI purpose. The CGP is defined in TS 29.658 [209]. The terms ACF and CGP may change in the future as a result of possible addition of charging capabilities.

NOTE 2: External tariff received in real time (according to TS 29.658 [209]) is not supported for AoCC service in this release.

4.3.2 AoC interfaces

AoC has the following interfaces:

- Sh – for obtaining AoC-related subscription and formatting parameters from the HSS.
- ISC – for receiving RTTI from Auxiliary AoC Function (AACF) and for providing the AoC Information to the UE.
- Ro / Re – for obtaining Tariff and Cost Information; Ro shall be used for providing AoCC service and may be used for AoCI services.

AACF can be embodied in external nodes such as:

- Application Server
- Charging Determination Point (CDP) in a PSTN network
- SIP node in another IMS domain

Figure 4.3.2.1 shows possible locations of AACF nodes interacting with IMS ACF.

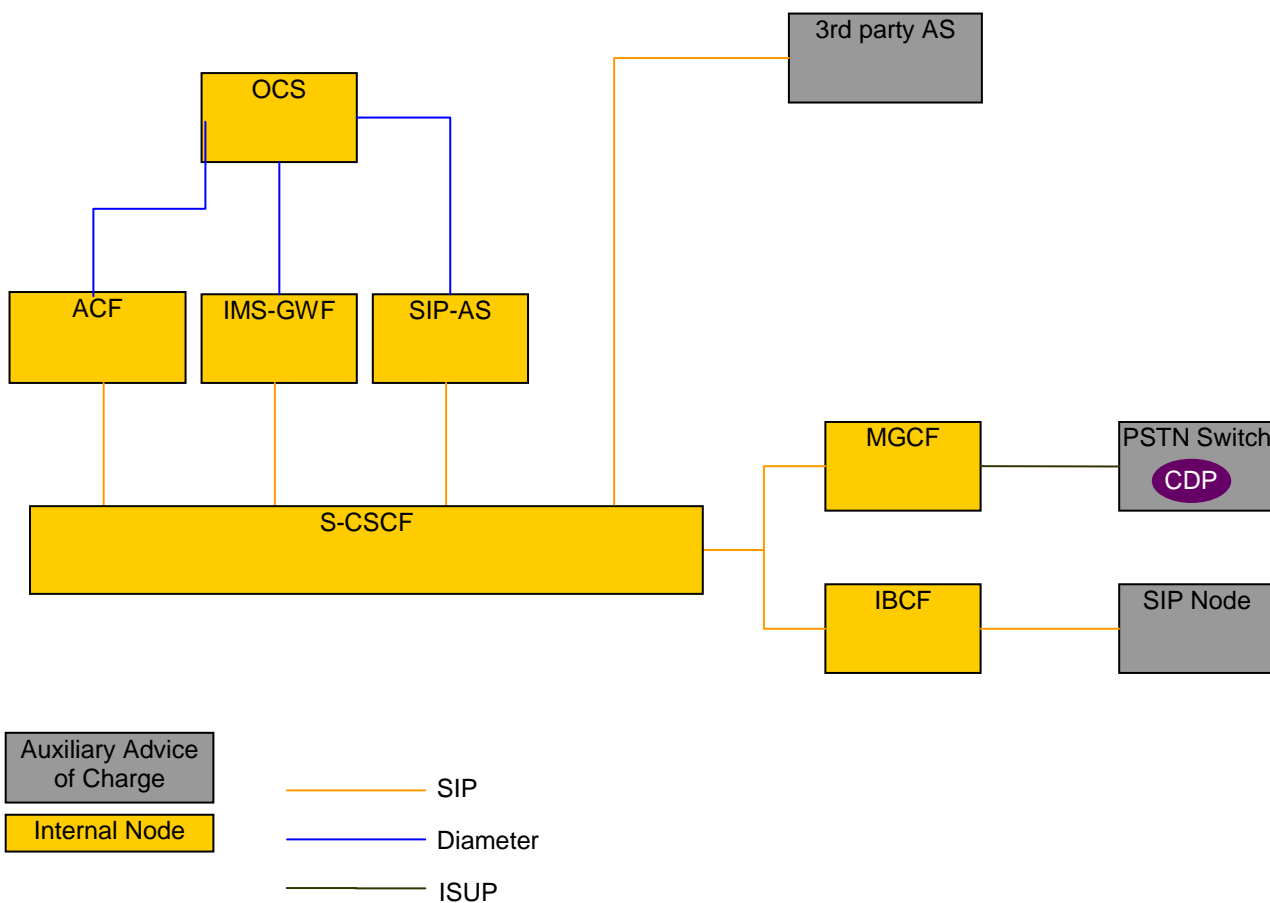

Figure 4.3.2.1: Logical AoC architecture with AACF

4.3.3 AoC interworking with other features

4.3.3.1 AoC and offline charging

4.3.3.1.1 Interworking for AoC service execution

For scenarios where the ACF is interworking with the offline charging feature and the service obligatory type is AoCI estimating Cost and/or Tariff Information may be performed using any of the following methods:

- Local determination using offline synchronization of tariff information - The ACF may synchronize out of band the tariff information from the charging domain. In this case, the ACF needs to have an independent rating function.
- Interactively via the CDF through Ro - ACF may obtain the tariff information interactively from the CDF.
- Interactively via the OCS through Ro - Offline subscribers can be perceived as online subscribers with unlimited balance (or very high balance that practically implies that). This approach enables the ACF to have unified flow of messages for offline and online subscribers in providing AoC Information.

For scenarios where the ACF is interworking with the offline charging feature and the service obligatory type is AoCC determining Cost and/or Tariff Information shall be via the OCS through Ro.

4.3.3.1.2 AoC invocation recording

When ACF is triggered on behalf of a service and results in the AoC Information delivered to the UE, this ACF may also generate AoC related Rf messages as described in clause 6.3.1.3.

4.3.3.2 AoC and online charging

For scenarios where the ACF is interworking with the online charging feature and the service obligatory type is AoCI estimating Cost and/or Tariff Information may be performed using any of the following methods:

- Local determination using offline synchronization of tariff information - The ACF may synchronize out of band the tariff information from the charging domain. In this case, the ACF needs to have an independent rating function.
- Interactively via the OCS through Ro.

For scenarios where the ACF is interworking with the online charging feature and the service obligatory type is AoCC, determining Cost and/or Tariff Information shall be via the OCS through Ro.

NOTE 1: The OCS has a rating function, performs correlations and calculates the costs. The OCS is responsible to determine the final cost of the service. Hence the OCS results shall be used for AoCC service (obtained through Ro).

For calculating the actual Cost when the tariff / charge is determined by 3rd party, the OCS needs to obtain the 3rd party tariff / add-on charge in real time. The ACF is responsible for obtaining the tariff / charge information and translating it into the appropriate Debit Units Request in the Ro. The OCS may take further considerations as of the actual Cost (e.g. add on charges, discounts).

NOTE 2: Therefore it is highly recommended that the ACF and the IMS-GW functions is unified at least for the online subscriptions.

4.3.3.3 AoC and RTTI

The AoC service shall receive the Tariff or Cost provided in real time by the external network or service provider (e.g. interconnection scenarios or 3rd party services), according to TS 29.658 [209]. The AoC Information, provided to the UE, may take the provided information into consideration.

NOTE: This feature is valid only for AoCI service in this release.

5 AoC principles and flows

5.1 Common charge advice principles

AoC is a supplementary service which provides AoC Information to the UE in real-time. It may contain Cost and/or Tariff Information for the requested service and may be provided at the beginning, during or at the end of service execution.

5.2 AoC in GSM networks (CAI description)

The Charge Advice Information (CAI) is described in TS 22.024 [203], TS 22.086 [204], TS 23.086 [205] and TS 24.086 [206].

5.3 AoC in IMS

5.3.1 Basic principles and definitions

AoC uses the Debit / Reserve Units operation that is specified in TS 32.299 [50].

AoC Information can be provided in two cases:

- AoC Enquiry – An independent request with no Credit-Control implications;
- Debit Unit Request - In conjunction with the Debit / Reserve Units Requests IEC, ECUR, SCUR.

In the ECUR & SCUR, the Advise of charge is supported as part of the Debit Units Request[Initial, Update, Terminate].

Both stage 2 and stage 3 mechanisms for the three cases for online charging are detailed in TS 32.299 [50].

5.3.2 Message flows and types for offline charging

5.3.2.0 Introduction

The message flows in this clause are based on the signalling flows specified in TS 24.647 [208].

The basic IMS session establishment for a user registered to AoC service(s) is depicted in the annex B. This basic call-flow helps describing in the future the message flows for AoC-S, AoC-D, AoC-E and also including cases where information are received from RTTI messages.

Editor's Note: The detailed AoC call-flows are FFS.

5.3.2.1 Successful session establishment: AoC-S with AoC Information in reliable 1xx response (originating side)

Figure 5.3.2.1.1 shows the transactions for the successful delivery of the AoC Information in 1xx response to the originating subscriber during session establishment originated by a UE.

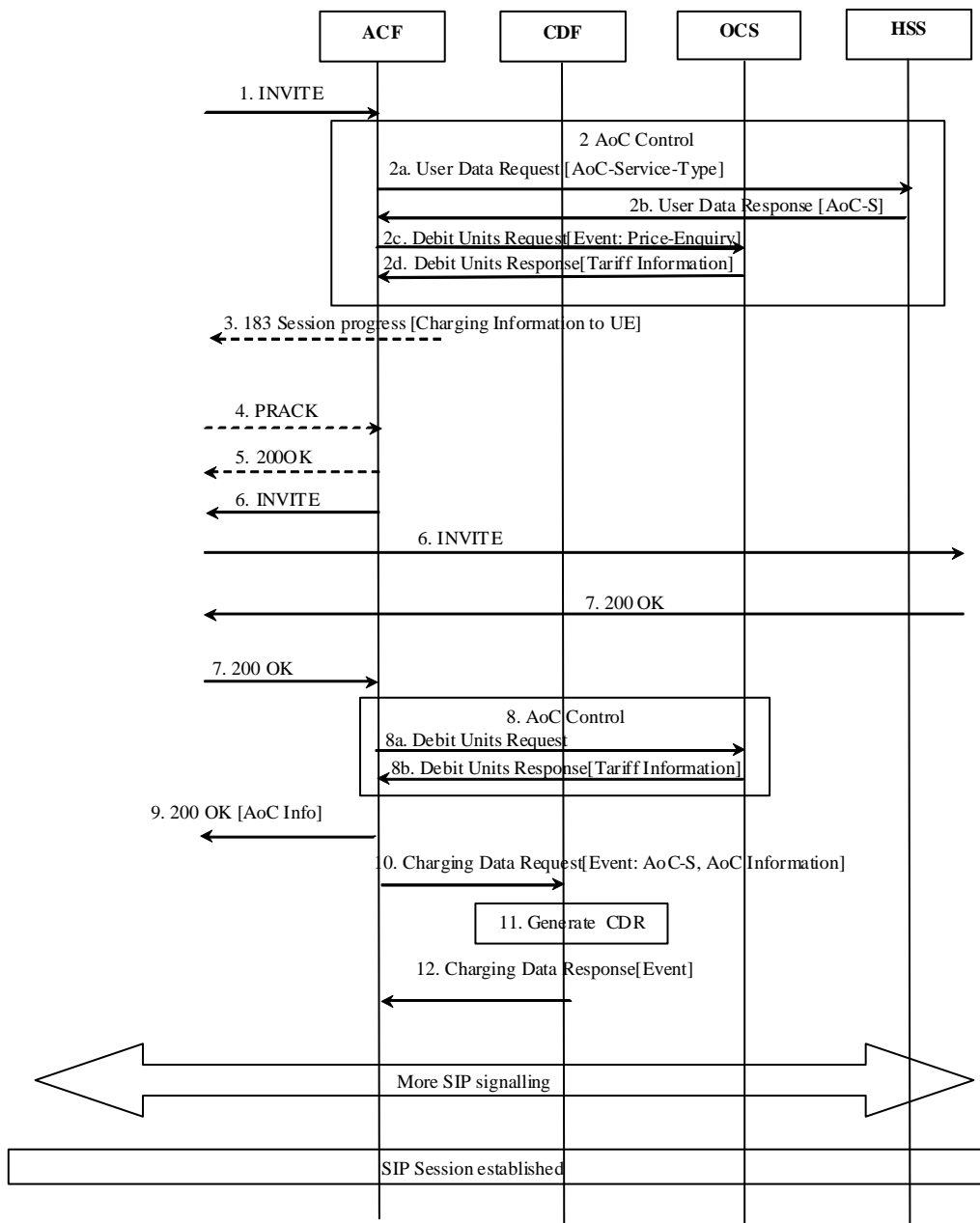

Figure 5.3.2.1.1: Message sequence chart for session establishment (1xx Response) with AoC-S

- Step 1: An initial SIP INVITE request is received in the S-CSCF. This request is forwarded to the ACF.
- Step 2: The ACF received the AoC Type = [AoC-S] and queries the OCS for Tariff Information.
- Step 3: The AoC-S information is included in SIP 183 response.
- Step 4: The UE acknowledges the SIP 183 with PRACK.
- Step 5: AoC Function responses with SIP 200 OK.

- Step 6: The SIP INVITE request is received in the S-CSCF and forwards this request.
- Step 7: The S-CSCF receives the SIP 200 OK response and forwards this response.
- Step 8: The ACF queries the OCS and maps the Tariff Information into the AoC Information for further proceeding.
- Step 9: The ACF inserts the AoC-S and resulting "AoC information XML body" as defined in TS 24.647 [208], in the SIP 200 OK response, and the S-CSCF forwards it towards UE
- Step 10: The ACF sends a Charging Data Request with AoC service type and AoC Information indicating EVENT_RECORD to the CDF.
- Step 11: The CDF generates the ACF-CDR to record the AoC service type and AoC Information.
- Step 12: The CDF acknowledges the reception of the Charging Data Response.

5.3.2.2 Mid-session procedure: AoC-S with AoC Information in a SIP INFO request

Figure 5.3.2.2.1 shows the transactions for the successful delivery of the AoC Information to the originating subscriber when a tariff change is detected by AoC Function.

NOTE: This case is relevant when AoC-S is activated.

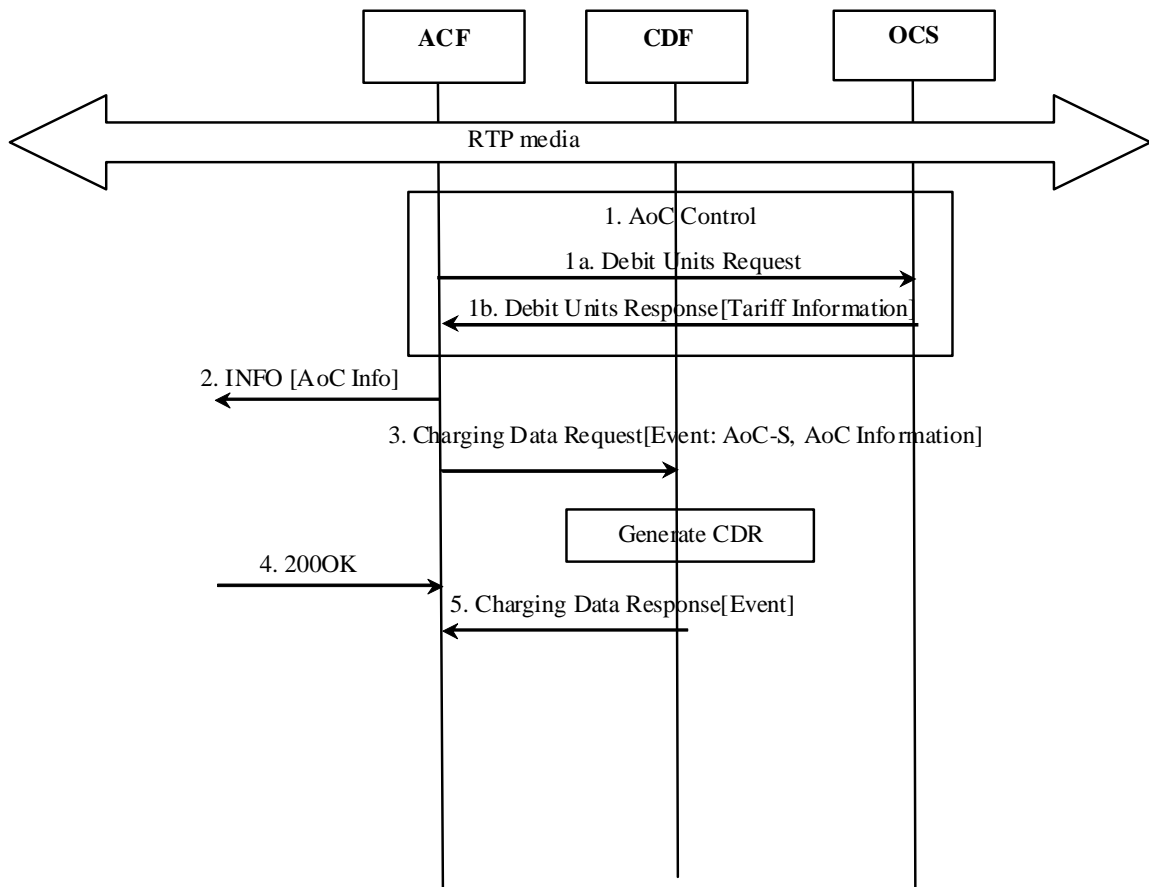

Figure 5.3.2.2.1: Message sequence chart for mid-session procedure with AoC-S

- Step 1: The ACF detects that tariff is changed and queries the OCS for Tariff Information.
- Step 2: SIP INFO request is send with AoC-S and resulting "AoC information XML body" as defined in TS 24.647 [208].
- Step 3: The ACF sends a Charging Data Request with AoC service type and AoC Information indicating EVENT_RECORD to the CDF.
- Step 4: SIP 200 OK is received.
- Step 5: The CDF acknowledges the reception of the Charging Data Response and generates the ACF-CDR.

5.3.2.3 Session release: AoC-E – originating party clears

Figure 5.3.2.3.1 shows the transactions for the successful delivery of the AoC Information to the originating subscriber when session is released by originating party.

NOTE: This case is relevant also when AoC-D is activated.

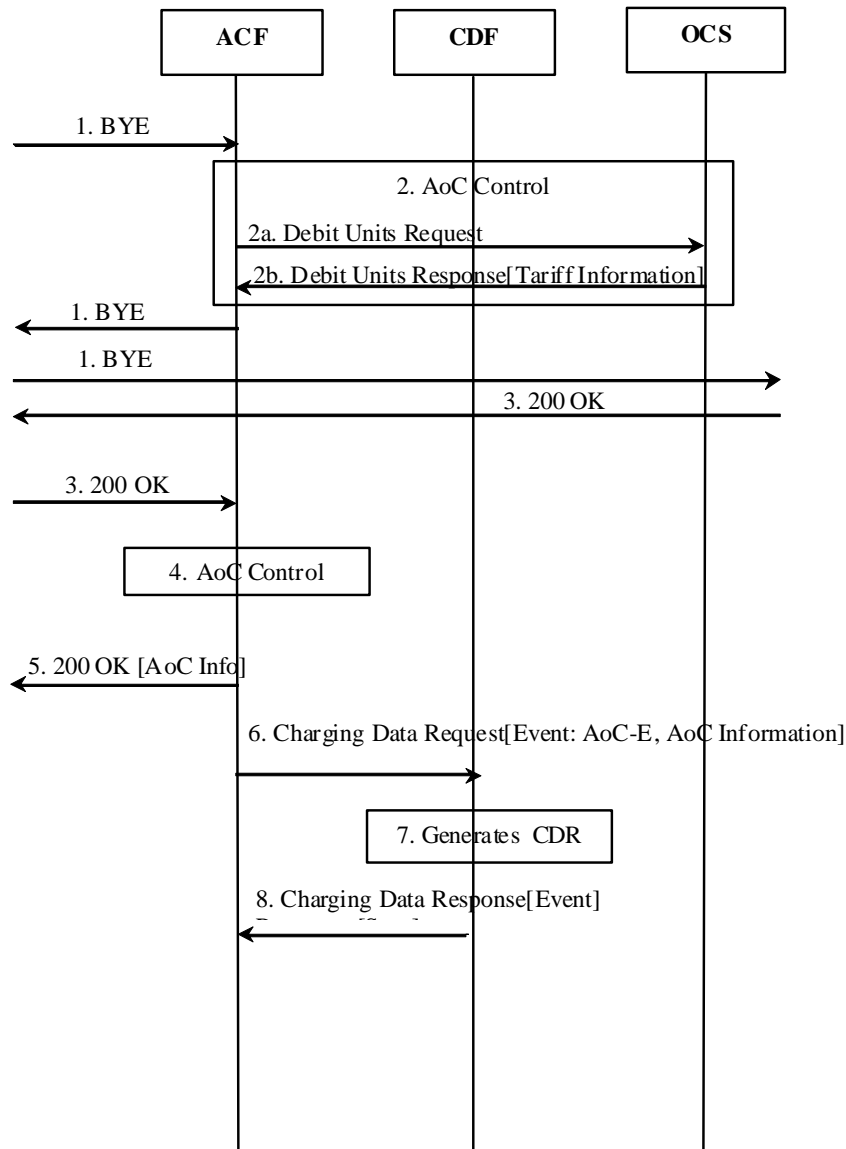

Figure 5.3.2.3.1: Message sequence chart for session release originating party clears

- Step 1: A SIP session is released by sending a SIP BYE message. The S-CSCF forwards this message to the ACF and forwards this request.
- Step 2: The ACF received the AoC Type = [AoC-E] and queries the OCS for Tariff Information.
- Step 3: The S-CSCF receives the SIP 200 OK response and forwards this response.
- Step 4: The ACF maps the Tariff Information into the AoC Information for further proceeding.
- Step 5: The ACF inserts the AoC-S and resulting "AoC information XML body" as defined in TS 24.647 [208], in the SIP 200 OK response, and the S-CSCF forwards it towards UE

- Step 6: The ACF sends a Charging Data Request with AoC service type and AoC Information indicating EVENT_RECORD to the CDF.
- Step 7: The CDF generates the ACF-CDR to record the AoC service type and AoC Information.
- Step 8: The CDF acknowledges the reception of the Charging Data Response.

5.3.2.4 Session release: AoC-E – terminating party clears

Figure 5.3.2.4.1 shows the transactions for the successful delivery of the AoC Information to the originating subscriber when session is released by terminating party.

NOTE: This case is relevant also when AoC-D is activated.

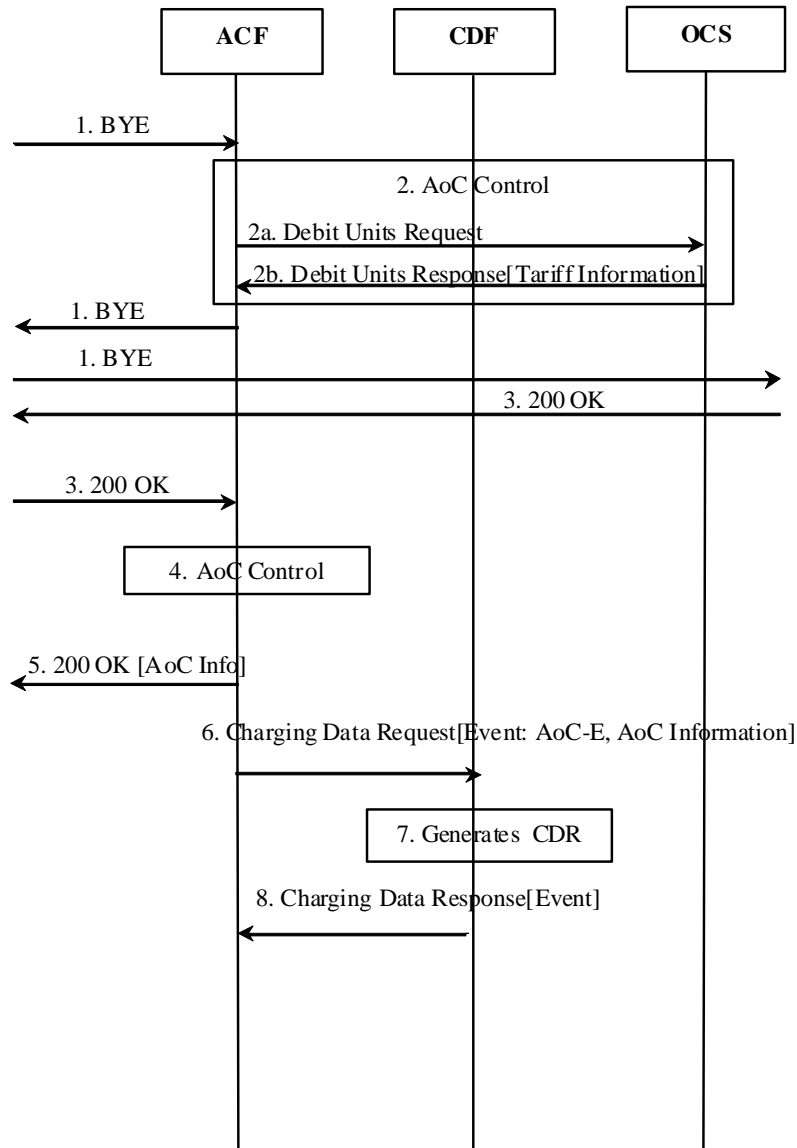

Figure 5.3.2.4.1: Message Sequence Chart for Session Release Terminating Party Clears

- Step 1: A SIP session is released by sending a SIP BYE message. The S-CSCF forwards this message to the AoC Function and forwards this request.
- Step 2: The AoC Function queries the OCS and converts the Tariff Information to AoC Information for AoC-E.
- Step 3: The S-CSCF receives the SIP 200 OK response and forwards this response.
- Step 4: The AoC Function maps the Tariff Information into the AoC Information for further proceeding
- Step 5: The ACF inserts the AoC-E and resulting "AoC information XML body" as defined in TS 24.647[208], in the SIP 200 OK response, and the S-CSCF forwards it towards UE.
- Step 6: The ACF sends a Charging Data Request with AoC service type and AoC Information indicating EVENT_RECORD to the CDF.

- Step 7: The CDF generates the ACF-CDR to record the AoC service type and AoC Information.
- Step 8: The CDF acknowledges the reception of the Charging Data Response.

5.3.2.5 AoC Function co-located with same AS providing the service

5.3.2.5.0 Introduction

The following flows show the transactions between an MMTel AS embedding the AoC Function for providing AoC as a MMTel supplementary service as defined in TS 22.173 [201].

5.3.2.5.1 Successful session establishment: AoC-S (originating side)

Figure 5.3.2.5.1.1 shows the transactions for the successful delivery of the AoC Information to the originating subscriber during session establishment for MMTel service originated by a UE.

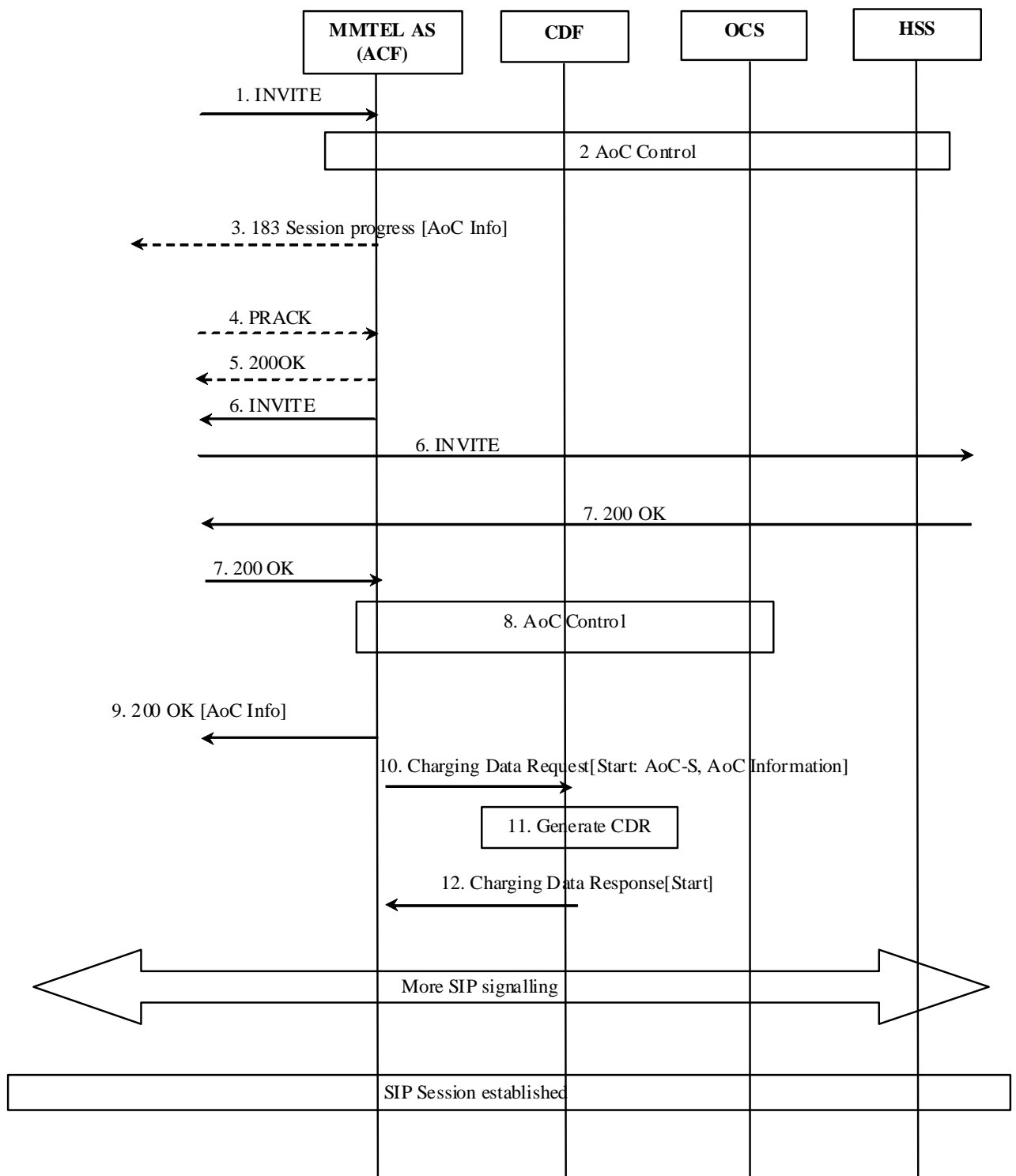

Figure 5.3.2.5.1.1: Message sequence chart for session establishment with AoC-S for MMTel service.

- Step 1: An initial SIP Invite Request is received in the S-CSCF. This request is forwarded to the MMTel AS embedding also ACF.
- Step 2: The ACF received the AoC Type = [AoC-S] and queries the OCS for Tariff Information for MMTel service.
- Step 3: The AoC-S "AoC information XML body" as defined in TS 24.647[208], is included in SIP 183 response.
- Step 4: The UE acknowledges the SIP 183 with PRACK.

- Step 5: AoC Function responds with SIP 200OK.
- Step 6: The SIP Invite Request is received in the S-CSCF and forwards this request.
- Step 7: The S-CSCF receives the SIP 200 OK response and forwards this response.
- Step 8: The AoC Function queries the OCS for the Tariff Information for MMTel service
- Step 9: The ACF inserts the AoC-S and resulting "AoC information XML body" as defined in TS 24.647 [208], in the SIP 200 OK response, and the S-CSCF forwards it towards UE
- Step 10: The MMTel AS sends a Charging Data Request indicating START to the CDF, for the start of MMTel service, and includes AoC-S and AoC Information supplementary service.
- Step 11: The CDF generates the MMTel-CDR recording also the AoC-S and AoC Information.
- Step 12: The CDF acknowledges the reception of the Charging Data Response.

5.3.2.5.2 AOC-D for serving party in SIP INFO request

The following figure 5.3.2.5.2.1 shows the transactions for AoC-D delivery to the serving subscriber, when a tariff change is detected by ACF during MMTel service.

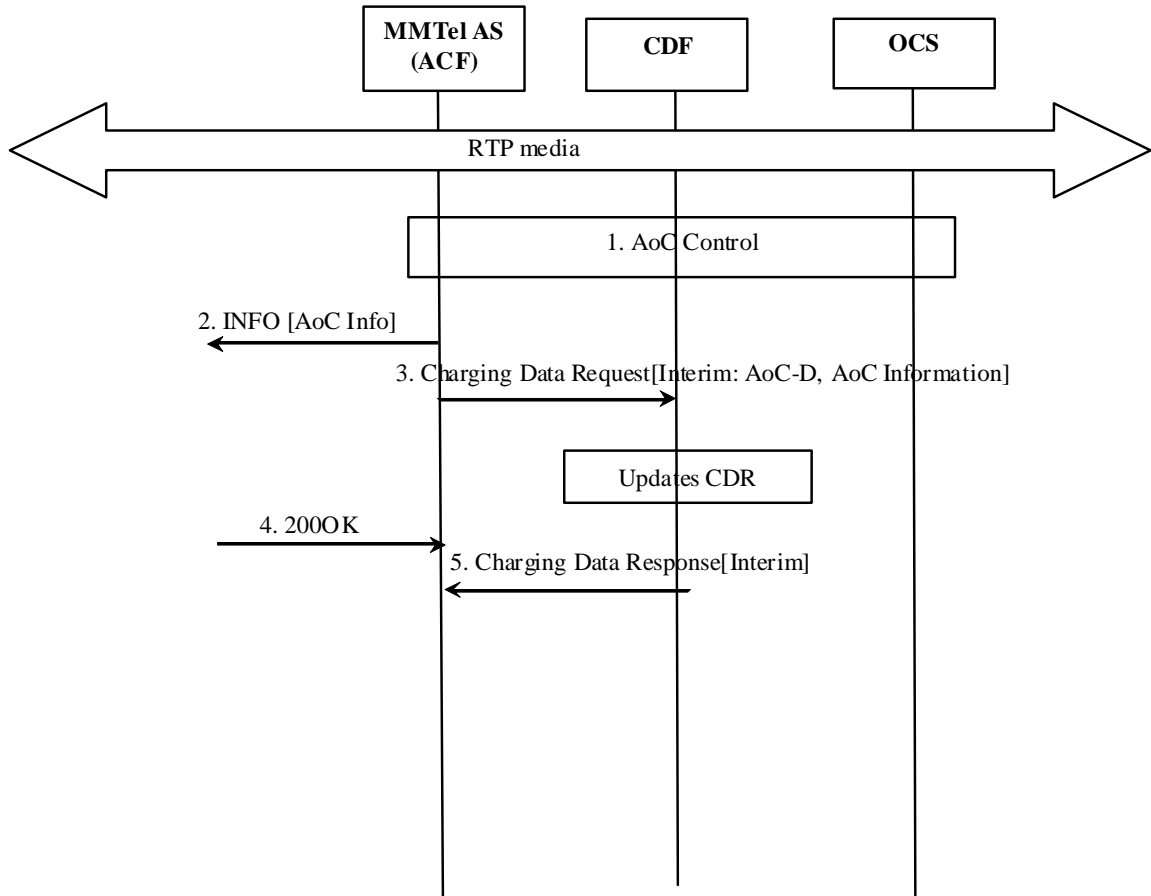

Figure 5.3.2.5.2.1: Message sequence chart for AoC-D to serving party

- Step 1: The ACF detects that tariff is changed for MMTel service and queries the OCS for Tariff Information.
- Step 2: SIP INFO request is sent with AoC-S and resulting "AoC information XML body" as defined in TS 24.647 [208].
- Step 3: The MMTel AS sends a Charging Data Request indicating INTERIM_RECORD to the CDF and includes AoC-D and AoC Information as supplementary service.
- Step 4: SIP 200OK is received.
- Step 5: The CDF acknowledges the reception of the Charging Data Response and updates the MMTel-CDR with AoC-D and AoC Information.

5.3.2.5.3 Session release: AoC-E – serving party clears

Figure 5.3.2.5.3.1 shows the transactions for delivery of the AoC-E to the serving subscriber when it releases MMTel service.

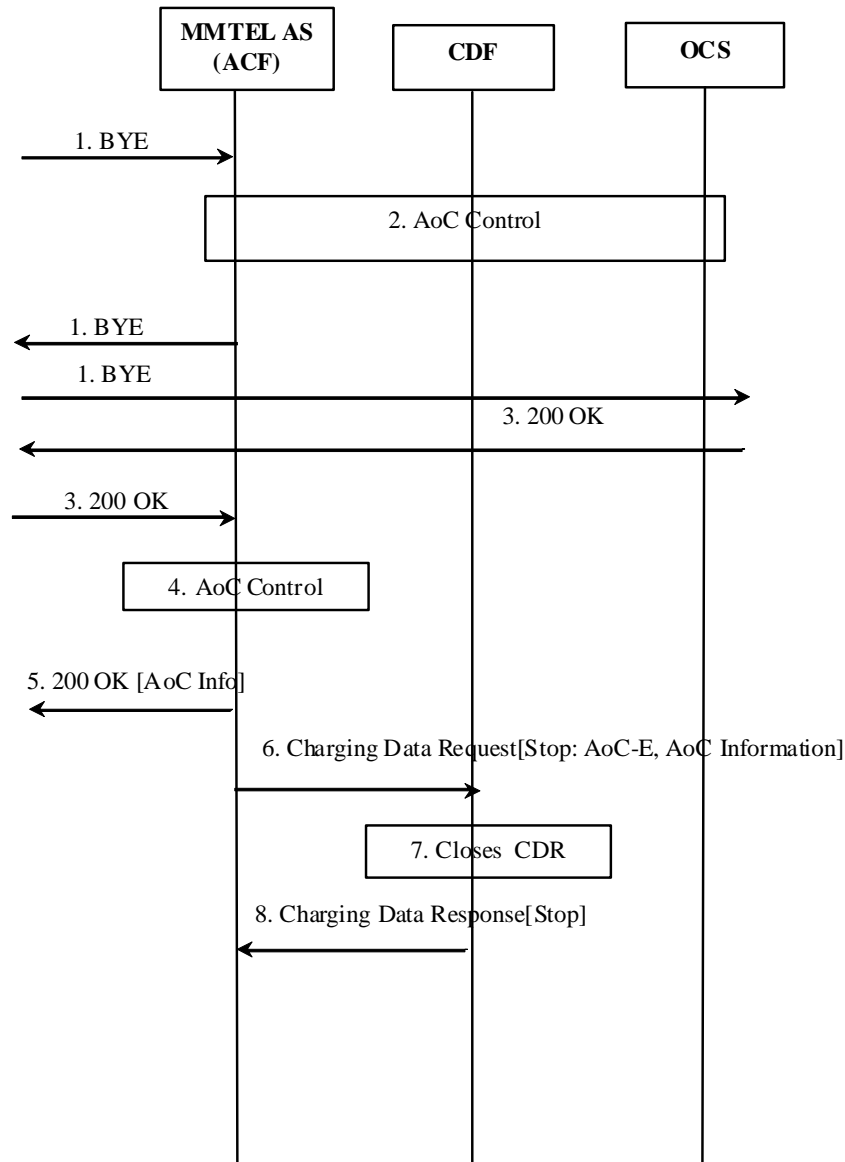

Figure 5.3.2.5.3.1: Message sequence chart for AoC-E when serving party clears

- Step 1: A SIP session is released by sending a SIP BYE message. The S-CSCF forwards this message to the MMTel AS and forwards this request.
- Step 2: The ACF queries the OCS for Tariff Information in order to perform AoC-E for MMTel service.
- Step 3: The S-CSCF receives the 200 OK response and forwards this response.
- Step 4: The AoC Function maps the Tariff Information into the AoC Information for further proceeding.
- Step 5: The ACF inserts the AoC-S and resulting "AoC information XML body" as defined in TS 24.647 [208], in the SIP 200 OK response, and the S-CSCF forwards it towards UE
- Step 6: The MMTel AS sends a Charging Data Request indicating STOP_RECORD to the CDF and includes AoC-E and AoC Information as supplementary service.

- Step 7: The CDF closes the MMTel-CDR with AoC-E and AoC Information included.
- Step 8: The CDF acknowledges the reception of the Charging Data Response.

5.4 AoC in Inter-connected

5.4.1 Principles

In case of interconnection scenarios or 3rd Party Services, the AoC service may be based on RTTI provided by the external network or service provider, as described in clause 4.3.3.3.

5.4.2 Scenarios

AoC Use cases based on RTTI are described in Annex A.1.2 and A.1.3.

5.4.3 Message flows

RTTI related signalling flows are described in TS 29.658 [209].

5.5 AoC support for PSTN/ISDN Emulation

The IMS based PSTN/ISDN Emulation Sub-system (PES) as defined in ETSI TS 182 012 [212] supports the emulation of PSTN/ISDN services for analogue/ISDN terminals connected to the NGN through residential gateways or access gateways. The Voice over IP Gateway (VGW) is a SIP-based gateway device that connects legacy equipment to the NGN. It plays the role of an IMS UE with regards to the P-CSCF. The Access Gateway Control Function (AGCF) is a SIP-based media gateway controller, which plays the combined role of an IMS UE and a P-CSCF with regards to the S-CSCF.

NOTE: This paragraph provides background information for AoC support for PES.
The normative definitions of PES are provided by ETSI TS 183 043 [213].

In order to support the emulation of AoC service for analogue terminals, the AoC Information is transferred to a VGW or an AGCF according to the AoC Extended XML schema defined in ETSI TS 183 043 [213].

The AoC Extended XML schema contains the following additional AoC Information elements: 'pes_aoc-s_phase_duration' and 'pes transitioning behaviour'.

The decision which "AOC information XML body" is applicable depends on signalling information. Further details, as well as general rules how to populate the AoC Extended XML parameters are defined in ETSI TS 183 043 [213].

For ISDN terminals, the AoC emulation is based on TS 24.647 [208].

6 Definition of AoC Information

6.0 General

The following clauses describe an overall AoC Information model that enables the modelling of the various data flowing to and from the AoC Function (ACF). The model is followed by a data structure to be used in the Ro and the Rf reference points. Suggested data mapping to the model is provided in the informative Annex B.

6.1 AoC Information model principles

The AoC Information model is a logical representation of the AoC data internal to the AoC Function (ACF).

The AoC Information model has to adhere to the following principles:

- CAI element mapping ability – The model shall allow the mapping of CAI elements into AoC tariff (according to TS 22.024 [203]).
- UE AoC data mapping ability - The AoC Information model shall allow the mapping of AoC into UE format (according to TS 24.647 [208]) respectively ETSI TS 183 043 [213] according to Annex C2)
- NNI data mapping ability – Be able to map incoming RTTI (according to TS 29.658 [209]) into the AoC Information model
- Protocol data mapping ability – The ability to map Debit / Reserve Units Request and Response (in TS 32.299 [50]) to the AoC Information model. i.e.:
 - Input: Service ID - The model shall allow the charging domain selecting tariffs based on the Service ID for offline and online charging.
 - Input: Service Units – The model shall allow representing tariffs based on all different unit types (monetary and non-monetary) of Requested Requested-Service-Units for online charging.
 - Output: Cost Information – The model shall allow representing determined charges by the charging Domain in Cost Information for offline and online charging.
 - Output: Ro data mapping ability – Be able to map information by the charging domain into the AoC Information model.
- Inter Operator Tariff schemes support – The AoC Information model shall support inter operators tariffs (based on TS 22.115 [101]); i.e. absolute add on charges and relative add on charges.
- AoC types – accommodate all AoC service types and AoC service obligatory type data.

6.2 AoC Information model

The AoC Information heading denotes the AoC obligatory type.

AoC Information comprises of two parts:

- the Cost Information e.g. AoC related accumulated and/or incremental cost;
- the Tariff Information for the requested service to be applied onward. A tariff switch time can occur. The tariff in effect after the switch time can be added to the model.

Figure 6.2.1 depicts the AoC Information model.

The Tariff Information contains the current Tariff and may optionally denote the anticipated Tariff after a Tariff Switch Time.

The Tariff Information may be related to a tariff given by a 3rd party provider. The Tariff may add additional tariff, change currency or place a mark-up (or discount) on top of the 3rd party provider Tariff. Thus Tariff Information can be chained numerous of times, based on the business value chain.

Each Tariff defines a Currency Code for monetary tariffs or none when the tariff is metered in non monetary units.

A Tariff may be defined by using multi dimensional rating elements. Each dimension is identified through the Unit Type. Any combination of rating elements can be provided. If a tariff is a mark-up on top of a 3rd party provider tariff no rating elements are provided in the tariff information model.

Each rating element is comprized of the Unit Type that describes the units to be measured, the number of units (Unit Value), what is the Cost (Cost Value) associated of consuming this number of units and for how many units this rate is applicable (Unit Threshold). Chaining rating elements of the same dimension is possible, as long as a Unit Threshold is provided. The last rating element in the chain may be provided without a Unit Threshold. A rating element without a Unit Threshold denotes that the rate is applicable as long as the Tariff is in effect.

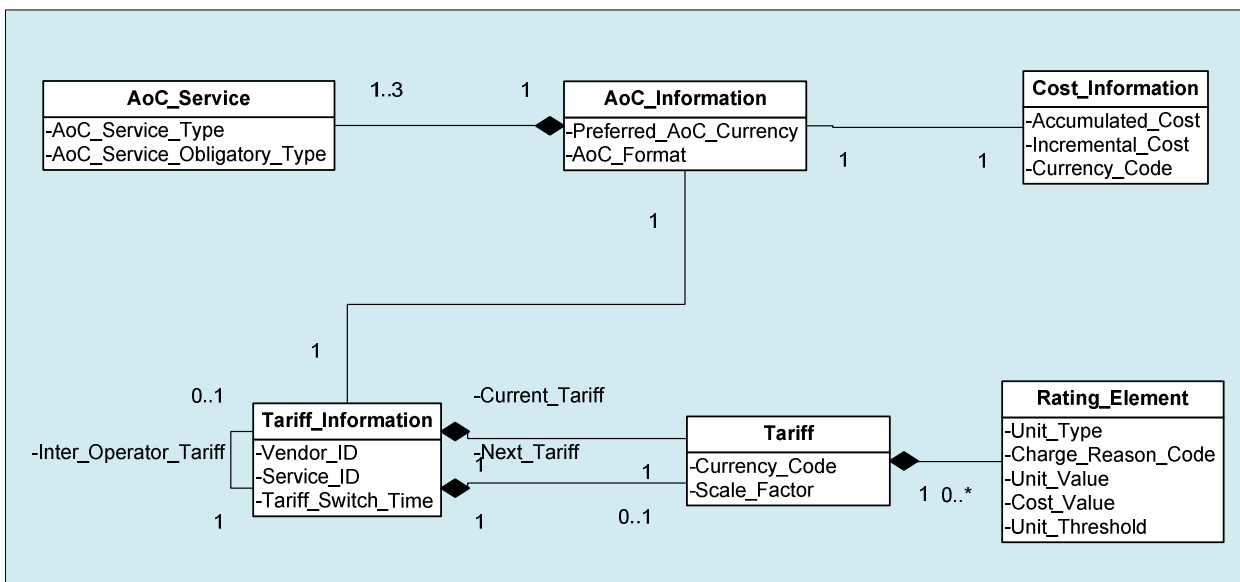

Figure 6.2.1: AoC Information model

6.3 AoC data definition

6.3.1 Ro message contents

6.3.1.1 Summary of AoC message formats

The AoC Service uses the Debit / Reserve Units Request and Debit / Reserve Units Response messages defined in TS 32.299 [50]. AoC service can be used in a request type price enquiry or complementary to regular Debit Units Request as described in clause 5.3.1.

Table 6.3.1.1.1 describes the use of these messages for AoC.

Table 6.3.1.1.1: AoC messages reference table

Message	Source	Destination
Debit / Reserve Units Request	ACF	OCS
Debit / Reserve Units Response	OCS	ACF

6.3.1.2 Structure for the Debit / Reserve Units message formats

6.3.1.2.0 General

This clause describes the information elements used in the Debit / Reserve Units operation messages and the category in the tables are used according to the charging data configuration defined in clause 5.4 of TS 32.240 [1].

6.3.1.2.1 Debit / Reserve Units Request message

Table 6.3.1.2.1.1 illustrates the basic structure of a Debit / Reserve Units Request message from the ACF as used for AoC service.

Table 6.3.1.2.1.1: Debit / Reserve Units Request message content

Information Element	Category	Description
Session Identifier	M	Described in TS 32.299 [50]
Originator Host	M	Described in TS 32.299 [50]
Originator Domain	M	Described in TS 32.299 [50]
Destination Domain	M	Described in TS 32.299 [50]
Operation Identifier	M	Described in TS 32.299 [50]
Operation Token	M	Described in TS 32.299 [50]
Operation Type	M	Described in TS 32.299 [50].
Operation Number	M	Described in TS 32.299 [50]
Destination Host	O _C	Described in TS 32.299 [50]
User Name	O _M	The field contains the Private User Identity described in IETF RFC 2486 [400]
Origination State	O _C	Described in TS 32.299 [50]
Origination Timestamp	O _C	Described in TS 32.299 [50]
Subscriber Identifier	O _M	This field contains the identification of the subscriber (i.e. MSISDN or SIP-URI) that uses the requested service.
Termination Cause	O _C	Described in TS 32.299 [50]
Requested Action	O _C	Described in TS 32.299 [50]
AoC Request Type	O _M	This field denotes if AoC Information is requested and what type of information is needed.
Multiple Operation	O _M	Described in TS 32.299 [50], only used if AoC services is used together with an online charging session.
Multiple Unit Operation	O _C	Described in TS 32.299 [50], only used if AoC services is used together with an online charging session.
Subscriber Equipment Number	O _C	Described in TS 32.299 [50]
Route Information	O _C	Described in TS 32.299 [50]
Service Information	O _M	Described in clause 6.3.2

6.3.1.2.2 Debit / Reserve Units Response message

Table 6.3.1.2.2.1 illustrates the basic structure of a DCCA message as used for the ACF. This message is always used by the OCS as specified below, independent of the receiving ACF and the Debit / Reserve Units Request request type that is being replied to. Service Information is used to send back the AoC Information.

Table 6.3.1.2.2.1: Debit / Reserve Units Response message content

Information Element	Category	Description
Session Identifier	M	Described in TS 32.299 [50]
Operation Result	M	Described in TS 32.299 [50]
Originator Host	M	Described in TS 32.299 [50]
Originator Domain	M	Described in TS 32.299 [50]
Operation Identifier	M	Described in TS 32.299 [50]
Operation Type	M	Described in TS 32.299 [50]
Operation Number	M	Described in TS 32.299 [50]
Operation Failover	O _c	Described in TS 32.299 [50]
Multiple Unit Operation	O _c	Described in TS 32.299 [50]
Operation Failure Action	O _c	Described in TS 32.299 [50]
Redirection Host	O _c	Described in TS 32.299 [50]
Redirection Host Usage	O _c	Described in TS 32.299 [50]
Redirection Cache Time	O _c	Described in TS 32.299 [50]
Route Information	O _c	Described in TS 32.299 [50]
Failed parameter	O _c	Described in TS 32.299 [50]
Service Information	O _c	Described in TS 32.299 [50]

6.3.1.3 Rf message content related to AoC service

6.3.1.3.0 Introduction

The ACF generates charging data transferred to the CDF using the Charging Data transfer operation, as described in the TS 32.299 [50] and the category in the tables are used according to the charging data configuration defined in clause 5.4 of TS 32.240 [1].

The *Charging Data Request* and *Charging Data Response* are used for this ACF Charging data transfer.

6.3.1.3.1 Charging Data Request message

Table 6.3.1.3.1.1 illustrates the basic structure of a *Charging Data Request* message as used for ACF Charging data transfer.

Table 6.3.1.3.1.1: Charging Data Request message content

Information Element	Category	Description
Session Identifier	M	Described in 32.299 [50]
Originator Host	M	Described in 32.299 [50]
Originator Domain	M	Described in 32.299 [50]
Destination Domain	M	Described in 32.299 [50]
Operation Type	M	Described in 32.299 [50]
Operation Number	M	Described in 32.299 [50]
Operation Identifier	O _M	Described in 32.299 [50]
User Name	O _C	Described in 32.299 [50]
Destination Host	O _C	Described in 32.299 [50]
Operation Interval	O _C	Described in 32.299 [50]
Origination State	O _C	Described in 32.299 [50]
Origination Timestamp	O _C	This field contains the time when the operation is requested.
Proxy Information	O _C	Described in 32.299 [50]
Route Information	O _C	Described in 32.299 [50]
Operation Token	O _M	Described in 32.299 [50]
Service Information	O _M	This field holds the 3GPP specific AoC Information and is described in clause 6.3.2

6.3.1.3.2 Charging Data Response message

Table 6.3.1.3.2.1 illustrates the basic structure of a *Charging Data Response* message as used for ACF Charging data transfer.

Table 6.3.1.3.2.1: Charging Data Response message content

Information Element	Category	Description
Session Identifier	M	Described in 32.299 [50]
Operation Result	M	Described in 32.299 [50]
Originator Host	M	Described in 32.299 [50]
Originator Domain	M	Described in 32.299 [50]
Operation Type	M	Described in 32.299 [50]
Operation Number	M	Described in 32.299 [50]
Operation Identifier	O _M	Described in 32.299 [50]
User Name	O _C	Described in 32.299 [50]
Operation Interval	O _C	Described in 32.299 [50]
Origination State	O _C	Described in 32.299 [50]
Origination Timestamp	O _C	Described in 32.299 [50]
Proxy Information	O _C	Described in 32.299 [50]

6.3.2 Definition of Service Information

Table 6.3.2.1.1: Service Information structure

Information Element	Category	Description
Service Information	O _C	This is a structured field and holds the 3GPP specific parameter for AoC service.
IMS Information	O _C	Described in TS 32.260 [20]
Inter Operator Identifier	O _C	Described in TS 32.260 [20]
Originating IOI	O _C	Described in TS 32.260 [20]
Service ID	O _C	Used to identify the third party service
AoC Information	O _C	Described in clause 6.3.3

6.3.3 Definition of AoC Information

6.3.3.0 General

The AoC Information parameter used for AoC is provided in the Service Information parameter.

6.3.3.1 AoC Information assignment for Service Information

The components in the Service Information that are use for AoC can be found in table 6.3.2.1.1.

Table 6.3.3.1.1: AoC Information structure

Information Element	Category	Description
AoC Information	O _C	This is a structured field and holds the 3GPP specific parameter for AoC service.
Tariff Information	O _C	This is a structured field and holds the Tariff specific parameters. The details are defined in clause 6.3.2.2. It can chain inter operator tariff.
AoC Cost Information	O _C	This is a structured field and holds the AoC cost specific parameters. The details are defined in clause 6.3.2.3.
AoC Subscription Information	O _C	Used by the AoC functions to inform the OCS about the AoC Subscription and Formatting parameters received from the HSS. When used by ACF for Charging data transfer as described in clause 6.3.1.3, only "AoC service" is present.

6.3.3.2 Definition of the Tariff Information

Tariff information is provided within the AoC Information.

The detailed structure of the Tariff Information can be found in the table 6.3.3.2.1.

Table 6.3.3.2.1: Tariff Information structure

Information Element	Category	Description
Tariff Information	O _C	This is a grouped field with one of many tariffs
Current Tariff	M	Tariff as defined in table 6.3.2.2-2 for the current time period.
Tariff Time Change	O _C	The tariffs switch time.
Next Tariff	O _C	Tariff as defined in table 6.3.2.2-2 for the next time period.

The detailed structure of a Tariff can be found in the table 6.3.3.2-2.

Table 6.3.3.2.2: Tariff structure

Information Element	Category	Description
Tariff	O _C	This is a grouped field with one of many tariffs
Currency_Code	O _C	Omitted if non-monetary units is used
Scale_Factor	O _C	A scaling factor on the whole calculation. Could be used for example between HPLMN and VPLMN.
Value_Digits	O _M	
Exponent	O _C	
Rate_Element	O _C	Group of Cost per unit values of unit type.
Charge Reason Code	O _C	Indicates a specific charge type e.g. Usage, AddOn Charge, Set-Up-Charge or Communication-Attempt-Charge
Unit_Type	O _M	The measuring unit; e.g. time, uplink volume, special service units
Unit_Value	O _M	The number of consumed units that incur the charge.
Value_Digits	O _M	
Exponent	O _C	
Unit_Cost	O _M	The associated Cost (in currency code) to be charged per Unit_value
Value Digits	O _M	
Exponent	O _C	
Unit_Quota_Threshold	O _C	An upper limit for consumed units where the rate is still valid

For example:

1. A rate of 20c for each Megabyte (total volume) up to 10 Megabyte is depicted as Unit type - TOTAL-OCTETS, Unit Value - 1,048,576, Cost – 20 and Unit threshold - 10,485,760.
2. A rate of 30c per 60s : Cost_Value = 30, Unit_Value =60 assuming appropriate settings for currency and unit_type.

6.3.3.3 Definition of AoC Cost Information

Cost information is provided within the AoC Cost Information.

The AoC Cost Information is only used in CCA and Charging Data Request.

The detailed structure of the AoC Cost Information can be found in the table 6.3.3.3.1.

Table 6.3.3.3.1: Structure of AoC Cost Information

Information Element	Category	Description
Accumulated_Cost	Oc	The amount charged since the beginning of the session
Value_Digits	O _M	
Exponent	Oc	
Incremental_Cost	Oc	The amount charged since the last report.
Value_Digits	O _M	
Exponent	Oc	
Currency_Code	Oc	Ommited if the ammount is in non-monetary units units

6.4 AoC subscription and formatting parameters

AoC-related subscription and formatting parameters are stored in the HSS and retrieved via Sh (see TS 29.364 [211]).

There are two sets of parameters retrieved from the HSS:

- Subscription based – general parameters pertaining the service registered per subscriber
- Formatting based – UE presentation preferences parameters

The subscription parameters are listed in table 6.4.1. The formatting parameters are listed in table 6.4.2.

Table 6.4.1: AoC subscription parameters

Information Element	Description	Values
AoC Service	A paired list of AoC Service type and AoC Service obligatory type	
AoC service type	Defines the type of AoC information to be provided to the subscriber.	AoC-S AoC-D AoC-E None
AoC service obligatory type	Defines whether AoC information is binding or non binding.	AoC for Information (AoCI) AoC for Charging (AoCC)
Preferred AoC currency	Defines the currency preferred by the subscriber	Currency

Table 6.4.2: AoC format parameter

Information Element	Description	Values
AoC format	Defines the format of the AoC information sent to the UE.	Monetary charging Information Element Non-monetary charging Information Element Charge Advice Information (CAI)

The following additional rules are applicable for AoC:

- Any combination of AoC service obligatory types and the AoC service types may co-exist.

Annex A (informative): AoC use cases

A.0 General

The following use cases detail a set of call scenarios that employ AoC services. The AoC services used are of type AoC-S, AoC-D and AoC-E. The use cases cover the AoC-S, AoC-D and AoC-E AoC service types and are applicable to either AoCI or AoCC service obligatory types.

A.1 Call scenarios with AoC Information provided at the beginning and/or during and/or at the end of the call

A.1.1 Outgoing call with Tariff provided by the charging domain at the start of the call

Actors:	Alan and Brendan are telecoms subscribers. Alan is an IMS subscriber with AoC service(s).
Description:	Tariff information is provided to Alan at the start of the call.
Preconditions:	AoC-related subscription status and user profile for Alan are stored in the HSS.
Post conditions:	Alan is ready to proceed with his call after receiving the tariff information applicable to the call.
Normal Flow:	<ul style="list-style-type: none"> Alan initiates an IMS session to call Brendan The tariff for the call is sent to Alan at the beginning of the call Alan receives the AoC Information on his UE
Alternative Flows:	
Assumptions:	The charging domain (online or offline) has the tariff for this call.
Notes and Issues:	

A.1.2 Outgoing call with Tariff provided by a remote network (PSTN or IMS) or a 3rd party service provider (AS) at the start of the call

Actors:	Alan and Brendan are telecoms subscribers. Alan is an IMS subscriber with AoC service(s).
Description:	Tariff information is provided to Alan at the start of the call.
Preconditions:	AoC-related subscription status and user profile for Alan are stored in the HSS.
Post conditions:	Alan is ready to proceed with his call after receiving the tariff information applicable (from the remote network or 3 rd party service provider) to the call.
Normal Flow:	<ul style="list-style-type: none"> Alan initiates an IMS session to call Brendan The tariff for the call is sent to Alan at the beginning of the call Alan receives the AoC Information on his UE
Alternative Flows:	
Assumptions:	The tariff for this call is not available in the charging domain (online or offline). Tariff information can be transferred in real-time from the remote network or 3 rd party service provider.
Notes and Issues:	

A.1.3 Outgoing call with Tariff provided by the charging domain in addition to an add-on charge received from the remote network (PSTN or IMS) or from a 3rd party service provider (AS)

Actors:	Alan and Brendan are telecoms subscribers. Alan is an IMS subscriber with AoC service(s).
Description:	Tariff information incorporating an add-on charge from an external source is provided to Alan at the start/during of the call.
Preconditions:	AoC-related subscription status and user profile for Alan are stored in the HSS.
Post conditions:	Alan is ready to proceed/continue with his call after receiving the tariff information applicable to the call.
Normal Flow:	<ul style="list-style-type: none"> Alan initiates an IMS session to call Brendan The tariff for the call is sent to Alan at the beginning of the call Alan receives the AoC Information on his UE including the add-on charge from the remote network (PSTN or IMS) or from a 3rd party service provider.
Alternative Flows:	<ul style="list-style-type: none"> An IMS session between Alan and Brendan is proceeding The tariff for the call is sent to Alan during the call Alan receives the AoC Information on his UE including the add-on charge from the remote network (PSTN or IMS) or from a 3rd party service provider.
Assumptions:	The charging domain (online or offline) has the tariff for this call. Add-on charges can be transferred in real-time for the remote network or 3 rd party service provider.
Notes and Issues:	

A.1.4 Outgoing call with Tariff change provided by the charging domain during an on-going call

Actors:	Alan and Brendan are telecoms subscribers. Alan is an IMS subscriber with AoC service(s).
Description:	Tariff information is provided to Alan when there is a tariff switch during a call.
Preconditions:	AoC-related subscription status and user profile for Alan are stored in the HSS. There is an on-going call between Alan and Brendan.
Post conditions:	Alan is ready to continue his call with Brendan after receiving the updated tariff information that is now applicable to the call.
Normal Flow:	<ul style="list-style-type: none"> Alan initiates an IMS session to call Brendan. A tariff switch relevant to this call occurs. The new tariff for the call is sent to Alan. Alan receives the updated tariff information on his UE.
Alternative Flows:	
Assumptions:	The charging domain (online or offline) has the tariff for this call.
Notes and Issues:	

A.1.5 Outgoing call with regular Cost updates provided by the charging domain during an on-going call

Actors:	Alan and Brendan are telecoms subscribers. Alan is an IMS subscriber with AoC service(s).
Description:	Cost information is provided to Alan at regulated periods during a call.
Preconditions:	AoC-related subscription status and user profile for Alan are stored in the HSS. There is an on-going call between Alan and Brendan.
Post conditions:	Alan is ready to continue his call with Brendan after receiving the accumulated cost information that is now applicable to the on-going call.
Normal Flow:	<ul style="list-style-type: none"> Alan initiates an IMS session to call Brendan. The duration of the call exceeds a predefined marker. The accumulated cost for the call to date is sent to Alan. Alan receives the updated cost information on his UE.
Alternative Flows:	
Assumptions:	The charging domain can determine the accumulated costs for this call in real-time.
Notes and Issues:	

A.1.6 Outgoing call with Cost summary provided at the end of the call

Actors:	Alan and Brendan are telecoms subscribers. Alan is an IMS subscriber with AoC service(s).
Description:	Cost information is provided to Alan at the end of a call.
Preconditions:	AoC-related subscription status and user profile for Alan are stored in the HSS. There is an on-going call between Alan and Brendan.
Post conditions:	Alan has completed his call with Brendan and receives the accumulated cost information that is now applicable to the preceding call.
Normal Flow:	<ul style="list-style-type: none"> Alan terminates an IMS session for a call to Brendan. The accumulated costs for the call are sent to Alan. Alan receives the cost information on his UE.
Alternative Flows:	
Assumptions:	The charging domain can determine the accumulated costs for this call in real-time.
Notes and Issues:	

A.1.7 Incoming call with Tariff provided by the charging domain at the start of the call

Actors:	Alan and Brendan are telecoms subscribers. Brendan is an IMS subscriber with AoC service(s).
Description:	Tariff information is provided to Brendan at the start of the call.
Preconditions:	AoC-related subscription status and user profile for Brendan are stored in the HSS.
Post conditions:	Brendan is ready to proceed with his call from Alan after receiving the tariff information applicable to the call.
Normal Flow:	<ul style="list-style-type: none"> Alan initiates an IMS session to call Brendan The tariff for the call is sent to Brendan at the beginning of the call Brendan receives the AoC Information on his UE
Alternative Flows:	
Assumptions:	The charging domain (online or offline) has the tariff for this call. There are business rules that determine that Brendan is the charged party for this call.
Notes and Issues:	

Annex B (informative): Message flow for basic IMS session establishment and interaction with online charging

This annex describes the basic IMS session establishment for a user registered for AoC service(s) and the interaction with online charging when an AS or the IMS GWF handles Debit Units operation.

Figure B.1 shows a basic IMS session establishment when an AS or the IMS GWF controls online charging.

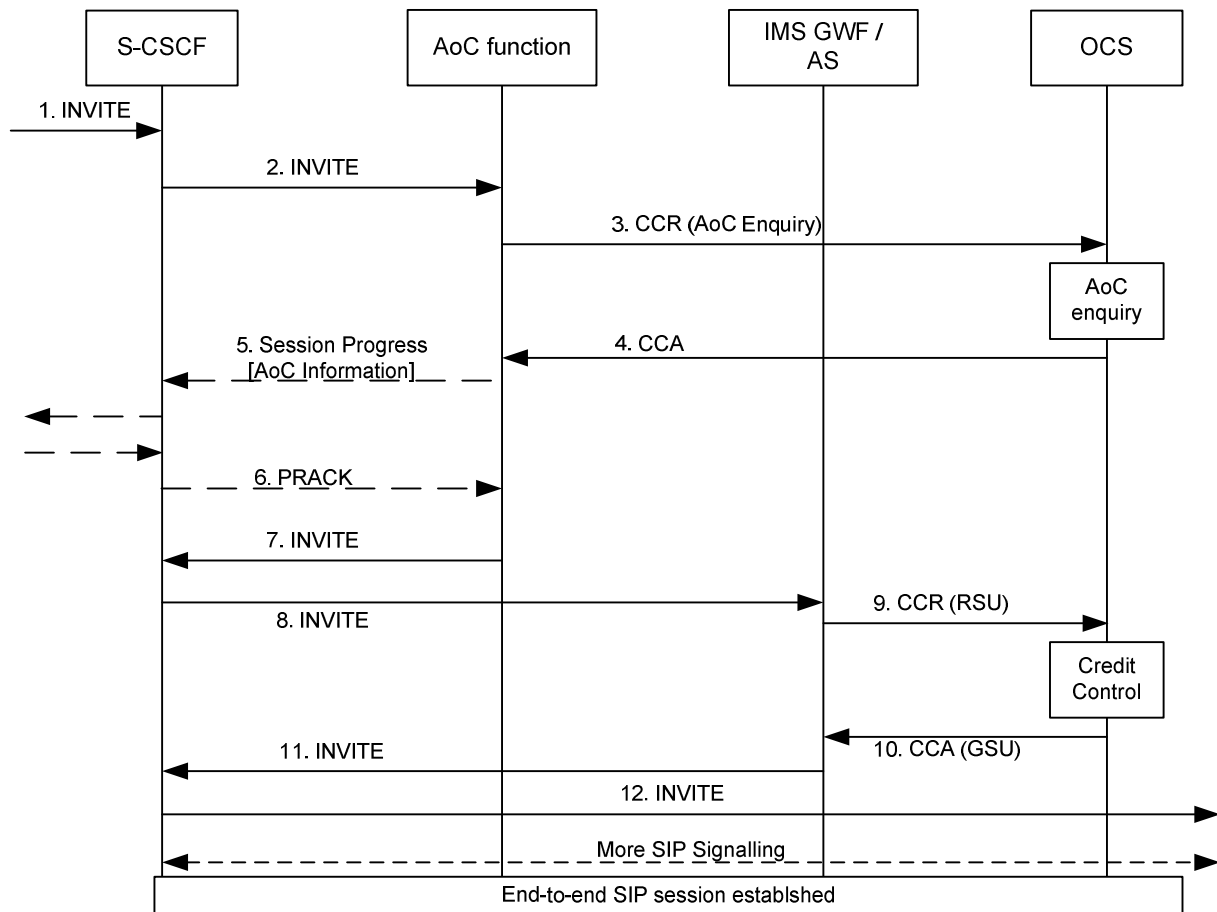

Figure B.1: Basic IMS session establishment for a user registered to AoC service(s) (online case controlled by AS / IMS GWF)

- Step 1: An initial SIP INVITE message is received in the S-CSCF.
- Step 2: The S-CSCF forwards this request to the AoC function.
- Step 3: The AoC function needs to request the tariff and or cost for this session. An AoC Enquiry is sent to the OCS in a Debit Units Request message.
- Step 4: The OCS sends back to the AoC function the information requested (tariff/cost).
- Step 5: The AoC Information is included by the ACF in a SIP 183 response.
- Step 6: UE acknowledgement of the 183 response is received at the ACF.
- Step 7: The SIP INVITE is forwarded to the S-CSCF.
- Step 8: The S-CSCF forwards the SIP INVITE message to the IMS GWF/AS to perform the online charging.

- Step 9: The IMS GWF/AS reserves a credit for the session. A Debit Units Request message is sent to the OCS. This Debit Units Request message is composed of a unit reservation request.
- Step 10: The OCS sends back to the IMS-GWF/AS a credit for the session.
- Step 11: The INVITE message is forwarded by the IMS GWF/AS to the S-CSCF.
- Step 12: The S-CSCF forwards the SIP INVITE message to the terminating party.

The service logic (AS/IMS GWF) and the AoC function may be unified. Thus, instead of sending two Debit Units Request messages (Debit Units Request [RSU] and Debit Units Request[AoC Enquiry] messages) towards the OCS, a grouped Debit Units Request message may be sent for performance reasons.

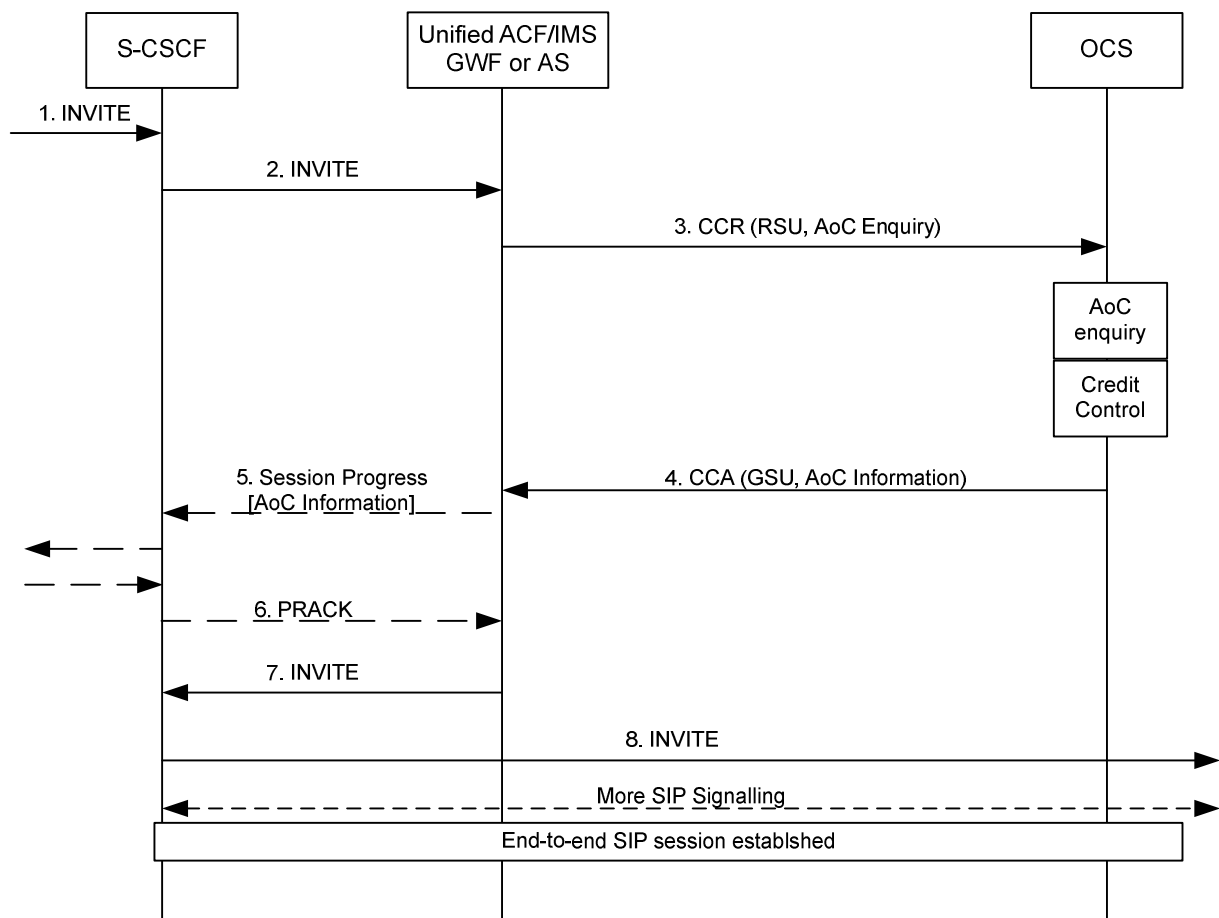

Figure B.2: Basic IMS session establishment for a user registered to AoC service(s) (online case controlled by unified (IMS GWF/AS) and ACF)

- Step 1: An initial SIP INVITE message is received in the S-CSCF.
- Step 2: The S-CSCF forwards this request to the AoC function.
- Step 3: The unified (IMS GWF or AS) and ACF generates a Debit Units Request message containing both a credit request and an AoC enquiry.
- Step 4: The OCS sends back to the unified (IMS GWF or AS) and ACF a response to the credit authorization and AoC enquiry.
- Step 5: The AoC Information is included by the unified (IMS GWF or AS) and ACF in a SIP 183 response.
- Step 6: UE acknowledgement of the 183 response is received at the unified (IMS GWF or AS) and ACF.
- Step 7: The SIP INVITE is forwarded to the S-CSCF.

- Step 8: The S-CSCF forwards the SIP INVITE message to the terminating party.

Annex C (informative): AoC Information mapping

C.0 General

This annex provides informative mapping concepts between the AoC Information to surrounding protocol formats.

C.1 AoC Information mapping to CAI element

Herby is a conceptual mapping of the CAI Element to the AoC Information.

The mapping is done by using 3 Rate Elements:

Rate Element 1 – Depicts the initial cost in the AoC

Rate Element 2 – Depicts the time related AoC

Rate Element 3 – Depicts the volume related AoC

Table C.1.1:

CAI parameter	Mapping guidance
e1 - Units per interval	Cost_Value in a Rate Element(2) with Unit-Type = TIME;
e2 - Seconds/time interval	Unit_Value in Rate Element(2)
e3 - Scaling Factor	Scale_Factor
e4 - Unit increment	Cost_Value in a Rate Element(1) with Unit-Type = TIME
e5 - Units per data interval	Cost_Value in a Rate Element(3) with Unit-Type = TOTAL-OCTETS;
e6 - Segments/data interval	Unit_Value in Rate Element(3)
e7 - Initial secs/t interval	Unit_Threshold in Rate Element(1)

When a service is known to be provided by CAMEL, the AoC function shall use a mapable construct of the AoC Information.

C.2 AoC Information mapping to charging Information Elements

Herby is a conceptual mapping advising how to populate the charging Information Element provided to the UE (as described in TS 24.647 [208] and ETSI TS 183 043 [213] as explicitly mentioned in the table C.2.1 below) out of the AoC Information.

Table C.2.1: AoC Information mapping

Information Element	Mapping guidance
Expressing Charging Rates	
- Price per time unit	When only one Rate Element with Unit Type = TIME exists
- Free of charge	When only one Rate Element with Unit Type = MONEY and Unit Value = 0 exists
- Flat rate	When only one Rate Element with Unit Type = MONEY and Unit Value > 0 exists
- Not available	No Rate Elements provided
Charged Items	
- Basic communication	When the Rate Element contains Charge Reason Code = Usage or no Charge Reason Code is available. NOTE: If no other Charged Items are applicable, Basic Communication shall be used as default value
- Communication attempt	This parameter may be populated when the Rate Element contains Charge Reason Code = Communication Attempt Charge NOTE: Alternatively, this information may be mapped into "Operation of service" (see below).
- Communication setup	This parameter may be populated when the Rate Element contains Charge Reason Code= Set Up Charge NOTE: Alternatively, this information may be mapped into "Operation of service" (see below).
- Operation of service	This parameter may be populated depending on Service specific Information or when the Rate Element contains Charge Reason Code <> Usage. NOTE: If this parameter is populated depending on the Charge Reason Code, Communication Attempt and Communication setup shall not be used.
- pes_aoc-s_phase_duration	The value of Unit_Quota_Threshold is mapped into pes_aoc-s_phase_duration when the AoC Extended XML schema is needed (see ETSI TS 183 043 [213])
Recorded Charges	Accumulated cost in AoC Cost Information
NOTE 1: Other legacy Charging Information Elements (e.g. Special charging code, Special charging arrangement and Billing Identification) are not supported in IMS.	
NOTE 2: In the case when the UNI interface can't transfer the incremental cost, then the user part can calculate it by deducting the previous accumulated cost information from the current accumulated cost information.	

'Additionally, the parameters in table C.2.2 are not supported by the Ro interface but locally configurable by operators.

Table C.2.2: AoC Information mapping – not supported

Type of Charging	This parameter is part of the AoC UNI XML information described in TS 24.647 [208].
Granularity	This parameter is part of the AoC UNI XML information described in TS 24.647 [208].
Pes-transitioning behaviour	This parameter is part of the AoC Extended XML schema described in ETSI TS 183 043 [213].

C.3 AoC Information mapping to NNI charging information

Herby is a conceptual mapping advising how to populate the incoming real time tariff information (as described in TS 29.658 [209]) to the AoC Information model.

Mapping concepts:

- Pulse based tariffs – Pulse based tariffs are translated to AoC Tariff with no Currency Code (i.e. non-monetary format).
- Sub Tariff – Each sub tariff is mapped as a new Rate Element
- Delay Until Start – The ACF shall buffer the message and wait for the 'start' signal.

NOTE: The Delay Until Start parameter in TS 29.658 [209] is not supported in this release.

- An Add-on charge provides single additional Cost Information which does not change the current tariff. When an Add-on charge is received via RTTI, the add-on charge shall be considered in the resulting Cost Information

Table C3.1: Data fields mapping

Information Element	Mapping guidance
Currency	Currency_Code
Call attempt charge	Rate-Element with Unit_Type = MONEY, This parameter may be populated when Charge Reason Code = CONNECTION_ATTEMPT_CHARGE.
Call setup charge	Rate-Element with Unit_Type = MONEY, This parameter may be populated when Charge Reason Code = CONNECTION_SETUP_CHARGE.
Add On charge	Rate-Element with Charge Reason Code = ADDON_CHARGE.
Communication charge	Rate-Element with Unit_Type = TIME.
Currency factor scale	Cost_Value in a Rate-Element with Unit_Type = TIME.
Currency factor	- Value Digits
Currency scale	- Exponent
Charge unit time interval	Unit-Value in a Rate-Element with Unit_Type = TIME. NOTE 1: this field is only used for non-monetary format. NOTE 2: A 50ms step support may not be supported in this release.
Tariff duration	Unit_Threshold in the Rate-Element as above
Sub tariff control	Periodic charge is mapped to Rate-Element with no Unit_Threshold or Unit_Threshold > Unit_Value. One time charge is mapped to Rate-element with Unit_Value = Unit_Threshold
Tariff switchover time	Tariff_Switch_Time

Annex D (informative): Bibliography

a) The 3GPP charging specifications

- 3GPP TS 32.250: "Telecommunication management; Charging management; Circuit Switched (CS) domain charging".
- 3GPP TS 32.251: "Telecommunication management; Charging management; Packet Switched (PS) domain charging".
- 3GPP TS 32.270: "Telecommunication management; Charging management; Multimedia Messaging Service (MMS) charging".
- 3GPP TS 32.271: "Telecommunication management; Charging management; Location Services (LCS) charging".
- 3GPP TS 32.272: "Telecommunication management; Charging management; Push-to-talk over Cellular (PoC) charging".
- 3GPP TS 32.273: "Telecommunication management; Charging management; Multimedia Broadcast and Multicast Service (MBMS) charging".
- 3GPP TS 32.274: "Telecommunication management; Charging management; Short Message Service (SMS) charging".
- 3GPP TS 32.275: "Telecommunication management; Charging management; MultiMedia Telephony (MMTel) charging".
- 3GPP TS 32.276: "Telecommunication management; Charging management; Voice Call Service Charging".
- 3GPP TS 32.298: "Telecommunication management; Charging management; Charging Data Record (CDR) parameter description".
- 3GPP TS 32.297: "Telecommunication management; Charging management; Charging Data Record (CDR) file format and transfer".
- 3GPP TS 32.296: "Telecommunication management; Charging management; Online Charging System (OCS) applications and interfaces".
- 3GPP TS 32.295: "Telecommunication management; Charging management; Charging Data Record (CDR) transfer".
- 3GPP TS 32.293: "Telecommunication management; Charging management; Proxy Function".

b) Common 3GPP specifications

- 3GPP TS 22.101: "Service aspects; Service Principles".
- 3GPP TS 22.115: "Service aspects; Charging and Billing".
- 3GPP TS 23.003: "Numbering, addressing and identification".
- 3GPP TS 27.001: "General on Terminal Adaptation Functions (TAF) for Mobile Stations (MS)".

c) other Domain and Service specific 3GPP / ETSI specifications-

d) Relevant ITU Recommendations

- ITU-T Recommendation D.93: "Charging and accounting in the international land mobile telephone service (provided via cellular radio systems)".
- ITU-T Recommendation E.164: "The international public telecommunication numbering plan".

- ITU-T Recommendation Q.767: "Application of the ISDN user part of CCITT signalling System No.7 for international ISDN interconnections".
- ITU-T Recommendation X.25: "Interface between Data Terminal Equipment (DTE) and Data Circuit-terminating Equipment (DCE) for terminals operating in the packet mode and connected to public data networks by dedicated circuit".
- ITU-T Recommendation X.121: "International numbering plan for public data networks".

e) Relevant IETF RFCs

- IETF RFC 959 (1985): "File Transfer Protocol".

Annex E (informative): Change history

Change history							
Date	TSG #	TSG Doc.	CR	Rev	Subject/Comment	Old	New
2008-01	S5-57	S5-080184	--	--	Fist draft submitted to SA5#57	-	0.0.1
2009-03	SP-43	SP-090059	--	--	Presentation to SA for approval	1.1.0	8.0.0
2009-06	SP-44	SP-090293	001	--	Correction of AoC Message Flows	8.0.0	8.1.0
2009-09	SP-45	SP-090536	002	--	Correction and alignment with TS 32.299	8.1.0	8.2.0
2009-09	SP-45	SP-090537	003	--	Aligning AoC- Information AVP with RTTI Information	8.2.0	9.0.0
2009-12	SP-46	SP-090721	004	--	Aligning Diameter commands and AVPs with TS 32.299	9.0.0	9.1.0
2010-06	SP-48	SP-100268	005	--	Correction of AoC UNI Protocol Mapping	9.1.0	10.0.0
2010-10	SP-49	SP-100501	008	--	Correction of Annex C2	10.0.0	10.1.0
2010-10	SP-49	SP-100501	008	--	Add Support of AoC Extended XML to AoC service	10.0.0	10.1.0
2010-12	SP-50	SP-100758	015	1	Correction of Reason-Code in the AoC Tariff Information – Align with 32.299	10.1.0	10.2.0
2010-12	SP-50	SP-100758	012	1	Correction of AoC Cost Information	10.1.0	10.2.0
2011-03	SP-51	SP-110108	017	2	Add missing AoC User to Network Interface (UNI) parameters: Type of Charging, Granularity and Pes-transitioning	10.2.0	10.3.0
2011-03	SP-51	SP-110112	018	2	Introduce AoC and offline charging Rf description to allow AoC offline charging	10.2.0	10.3.0
2011-03	SP-51	SP-110112	019	1	Provide offline AoC charging when the AoC Function is provided by MMTel AS - Align with 22.173	10.2.0	10.3.0
2011-03	SP-51	SP-110112	020	2	Clarify how 'AoC information' is presented to the UE	10.2.0	10.3.0
2011-03	SP-51	SP-110112	021	1	Clarification on AoC in interconnect	10.2.0	10.3.0
2011-03	SP-51	SP-110112	022	1	Correction on Incremental Cost information over UNI in AoC-D	10.2.0	10.3.0
2011-06	--	--	--	--	Minor editorial corrections	10.3.0	10.3.1
2012-09	SP-57	SP-120646	0025	1	Correction on AoC service support	10.3.1	10.4.0
2012-09	-	-	-	-	Update to Rel-11 version (MCC)	10.4.0	11.0.0
2013-12	SP-62	SP-130616	0027	-	Correction for use of Destination-Host AVP in ACR	11.0.0	11.1.0
2014-07	-	-	-	-	Rapporteur/MCC: General editorial changes and clean-up.	11.1.0	11.1.1
2014-09	SP-65	SP-140564	0028	1	Corrections for alignment between charging specifications	11.1.1	12.0.0
2014-12	SP-66	SP-140804	0029	-	Additional corrections for removal of I-WLAN solution	12.0.0	12.1.0
		SP-140805	0030	-	Corrections on definition for parameter category		
2016-01					Update to Rel-13 (MCC)	12.1.0	13.0.0

Change history							
Date	Meeting	TDoc	CR	Rev	Cat	Subject/Comment	New version
2017-03	SA#75					Promotion to Release 14 without technical change	14.0.0
2018-06	-	-	-	-	-	Update to Rel-15 version (MCC)	15.0.0
2020-07	-	-	-	-	-	Update to Rel-16 version (MCC)	16.0.0
2022-03	-	-	-	-	-	Update to Rel-17 version (MCC)	17.0.0
2024-04	-	-	-	-	-	Update to Rel-18 version (MCC)	18.0.0

History

Document history		
V18.0.0	May 2024	Publication