

# ETSI TS 136 410 V19.0.0 (2026-01)



TECHNICAL SPECIFICATION

**LTE;  
Evolved Universal Terrestrial  
Radio Access Network (E-UTRAN);  
S1 general aspects and principles  
(3GPP TS 36.410 version 19.0.0 Release 19)**



A GLOBAL INITIATIVE

---

**Reference**

RTS/TSGR-0336410vj00

---

**Keywords**

LTE

**ETSI**

---

650 Route des Lucioles  
F-06921 Sophia Antipolis Cedex - FRANCE

Tel.: +33 4 92 94 42 00 Fax: +33 4 93 65 47 16

Siret N° 348 623 562 00017 - APE 7112B  
Association à but non lucratif enregistrée à la  
Sous-Préfecture de Grasse (06) N° w061004871

---

**Important notice**

The present document can be downloaded from the  
[ETSI Search & Browse Standards application](#).

The present document may be made available in electronic versions and/or in print. The content of any electronic and/or print versions of the present document shall not be modified without the prior written authorization of ETSI. In case of any existing or perceived difference in contents between such versions and/or in print, the prevailing version of an ETSI deliverable is the one made publicly available in PDF format on [ETSI deliver repository](#).

Users should be aware that the present document may be revised or have its status changed, this information is available in the [Milestones listing](#).

If you find errors in the present document, please send your comments to the relevant service listed under [Committee Support Staff](#).

If you find a security vulnerability in the present document, please report it through our [Coordinated Vulnerability Disclosure \(CVD\)](#) program.

---

**Notice of disclaimer & limitation of liability**

The information provided in the present deliverable is directed solely to professionals who have the appropriate degree of experience to understand and interpret its content in accordance with generally accepted engineering or other professional standard and applicable regulations.

No recommendation as to products and services or vendors is made or should be implied.

No representation or warranty is made that this deliverable is technically accurate or sufficient or conforms to any law and/or governmental rule and/or regulation and further, no representation or warranty is made of merchantability or fitness for any particular purpose or against infringement of intellectual property rights.

In no event shall ETSI be held liable for loss of profits or any other incidental or consequential damages.

Any software contained in this deliverable is provided "AS IS" with no warranties, express or implied, including but not limited to, the warranties of merchantability, fitness for a particular purpose and non-infringement of intellectual property rights and ETSI shall not be held liable in any event for any damages whatsoever (including, without limitation, damages for loss of profits, business interruption, loss of information, or any other pecuniary loss) arising out of or related to the use of or inability to use the software.

---

**Copyright Notification**

No part may be reproduced or utilized in any form or by any means, electronic or mechanical, including photocopying and microfilm except as authorized by written permission of ETSI.

The content of the PDF version shall not be modified without the written authorization of ETSI.

The copyright and the foregoing restriction extend to reproduction in all media.

© ETSI 2026.  
All rights reserved.

---

# Intellectual Property Rights

## Essential patents

IPRs essential or potentially essential to normative deliverables may have been declared to ETSI. The declarations pertaining to these essential IPRs, if any, are publicly available for **ETSI members and non-members**, and can be found in ETSI SR 000 314: "*Intellectual Property Rights (IPRs); Essential, or potentially Essential, IPRs notified to ETSI in respect of ETSI standards*", which is available from the ETSI Secretariat. Latest updates are available on the [ETSI IPR online database](#).

Pursuant to the ETSI Directives including the ETSI IPR Policy, no investigation regarding the essentiality of IPRs, including IPR searches, has been carried out by ETSI. No guarantee can be given as to the existence of other IPRs not referenced in ETSI SR 000 314 (or the updates on the ETSI Web server) which are, or may be, or may become, essential to the present document.

## Trademarks

The present document may include trademarks and/or tradenames which are asserted and/or registered by their owners. ETSI claims no ownership of these except for any which are indicated as being the property of ETSI, and conveys no right to use or reproduce any trademark and/or tradename. Mention of those trademarks in the present document does not constitute an endorsement by ETSI of products, services or organizations associated with those trademarks.

**DECT™**, **PLUGTESTS™**, **UMTS™** and the ETSI logo are trademarks of ETSI registered for the benefit of its Members. **3GPP™**, **LTE™** and **5G™** logo are trademarks of ETSI registered for the benefit of its Members and of the 3GPP Organizational Partners. **oneM2M™** logo is a trademark of ETSI registered for the benefit of its Members and of the oneM2M Partners. **GSM®** and the GSM logo are trademarks registered and owned by the GSM Association.

---

# Legal Notice

This Technical Specification (TS) has been produced by ETSI 3rd Generation Partnership Project (3GPP).

The present document may refer to technical specifications or reports using their 3GPP identities. These shall be interpreted as being references to the corresponding ETSI deliverables.

The cross reference between 3GPP and ETSI identities can be found at [3GPP to ETSI numbering cross-referencing](#).

---

# Modal verbs terminology

In the present document "**shall**", "**shall not**", "**should**", "**should not**", "**may**", "**need not**", "**will**", "**will not**", "**can**" and "**cannot**" are to be interpreted as described in clause 3.2 of the [ETSI Drafting Rules](#) (Verbal forms for the expression of provisions).

"**must**" and "**must not**" are **NOT** allowed in ETSI deliverables except when used in direct citation.

# Contents

|   |    |
|---|----|
| Intellectual Property Rights .....  | 2  |
| Legal Notice .....  | 2  |
| Modal verbs terminology.....  | 2  |
| Foreword.....   | 5  |
| 1 Scope .....   | 6  |
| 2 References .....  | 6  |
| 3 Definitions and abbreviations.....  | 6  |
| 3.1 Definitions .....   | 6  |
| 3.2 Abbreviations .....   | 7  |
| 3.3 Specification notations .....   | 7  |
| 4 General aspects.....  | 7  |
| 4.1 E-UTRAN architecture.....   | 8  |
| 4.2 S1 interface general principles .....                                   | 8  |
| 4.3 S1 interface specification objectives .....                             | 9  |
| 4.4 S1 interface capabilities.....  | 9  |
| 4.5 S1 interface characteristics .....                                      | 9  |
| 4.5.1 Use of the Stream Control Transmission Protocol (SCTP).....           | 9  |
| 5 Functions of the S1 interface protocols and functional split .....        | 9  |
| 5.1 General .....   | 9  |
| 5.2 S1 UE context management function .....                                 | 9  |
| 5.3 E-RAB management functions.....   | 10 |
| 5.4 S1 link management function.....  | 10 |
| 5.4.1 GTP-U tunnels management function.....                                | 10 |
| 5.4.2 S1 signalling link management function.....                           | 10 |
| 5.5 Mobility functions for UEs in LTE_Active.....                           | 10 |
| 5.5.1 Intra-LTE handover .....  | 10 |
| 5.5.2 Inter-3GPP RAT handover .....   | 10 |
| 5.5.3 Mobility to CDMA2000 system .....                                     | 10 |
| 5.6 Paging function .....   | 10 |
| 5.7 Void.....   | 10 |
| 5.7a Roaming and access restriction support functions.....                  | 10 |
| 5.8 S1 interface management function .....                                  | 11 |
| 5.9 Coordination functions .....  | 11 |
| 5.9.1 Network sharing function .....  | 11 |
| 5.9.2 NAS node selection function .....                                     | 11 |
| 5.9.3 MME overload control function .....                                   | 11 |
| 5.10 Security function .....  | 11 |
| 5.10.1 Data confidentiality.....  | 11 |
| 5.10.1.1 Radio interface ciphering function.....                            | 11 |
| 5.10.1.2 Ciphering key management function .....                            | 11 |
| 5.10.2 Data integrity .....   | 12 |
| 5.10.2.1 Integrity checking .....   | 12 |
| 5.10.2.2 Integrity key management.....                                      | 12 |
| 5.11 Service and network access function.....                               | 12 |
| 5.11.1 Core network signalling data transfer function.....                  | 12 |
| 5.11.2 UE tracing.....  | 12 |
| 5.11.3 Location reporting function .....                                    | 12 |
| 5.11.4 LTE Positioning Protocol A (LPPa) signalling transfer function ..... | 12 |
| 5.11.5 Delivery of warning messages .....                                   | 12 |
| 5.12 RAN Information Management (RIM) function .....                        | 12 |
| 5.13 Configuration Transfer function.....                                   | 12 |
| 6 S1 interface protocol structure .....                                     | 13 |

|  |   |           |
|--|---|-----------|
| 6.1  | General .....   | 13        |
| 6.2  | S1-MME.....   | 13        |
| 6.3  | S1-U .....  | 14        |
| 7  | Other S1 interface specifications.....  | 14        |
| 7.1  | E-UTRAN S1 interface: layer 1 (3GPP TS 36.411).....                                 | 14        |
| 7.2  | E-UTRAN S1 interface: signalling transport (3GPP TS 36.412).....                    | 14        |
| 7.3  | E-UTRAN S1 interface: S1AP specification (3GPP TS 36.413).....                      | 14        |
| 7.4  | E-UTRAN S1 interface: data transport and transport signalling (3GPP TS 36.414)..... | 14        |
| <b>Annex A (informative): Change history .....</b> |   | <b>15</b> |
| History .....                                      |   | 16        |

---

# Foreword

This Technical Specification has been produced by the 3<sup>rd</sup> Generation Partnership Project (3GPP).

The contents of the present document are subject to continuing work within the TSG and may change following formal TSG approval. Should the TSG modify the contents of the present document, it will be re-released by the TSG with an identifying change of release date and an increase in version number as follows:

Version x.y.z

where:

- x the first digit:
  - 1 presented to TSG for information;
  - 2 presented to TSG for approval;
  - 3 or greater indicates TSG approved document under change control.
- y the second digit is incremented for all changes of substance, i.e. technical enhancements, corrections, updates, etc.
- z the third digit is incremented when editorial only changes have been incorporated in the document.

---

# 1 Scope

The present document is an introduction to the 3GPP TS 36.41x series of technical specifications that define the S1 interface for the interconnection of the evolved NodeB (eNB) component of the Evolved Universal Terrestrial Radio Access Network (E-UTRAN) to the Core Network (CN) of the Evolved Packet System (EPS).

---

## 2 References

The following documents contain provisions which, through reference in this text, constitute provisions of the present document.

- References are either specific (identified by date of publication, edition number, version number, etc.) or non-specific.
- For a specific reference, subsequent revisions do not apply.
- For a non-specific reference, the latest version applies. In the case of a reference to a 3GPP document (including a GSM document), a non-specific reference implicitly refers to the latest version of that document *in the same Release as the present document*.

- [1] 3GPP TR 21.905: "Vocabulary for 3GPP Specifications".
- [2] 3GPP TS 36.401: "Evolved Universal Terrestrial Radio Access Network (E-UTRAN); Architecture description".
- [3] 3GPP TS 36.411: "Evolved Universal Terrestrial Radio Access Network (E-UTRAN); S1 layer 1".
- [4] 3GPP TS 36.412: "Evolved Universal Terrestrial Radio Access Network (E-UTRAN); S1 signalling transport".
- [5] 3GPP TS 36.413: "Evolved Universal Terrestrial Access (E-UTRA); S1 Application Protocol (S1 AP)".
- [6] 3GPP TS 36.414: "Evolved Universal Terrestrial Radio Access Network (E-UTRAN); S1 data transport".
- [7] IETF RFC 4960 (2007-09): "Stream Control Transmission Protocol".
- [8] 3GPP TS 29.281: "General Packet Radio Service (GPRS); GPRS Tunnelling Protocol User Plane (GTPv1-U)".
- [9] 3GPP TS 23.401: "General Packet Radio Service (GPRS) enhancements for Evolved Universal Terrestrial Radio Access Network (E-UTRAN) access".
- [10] 3GPP TS 36.455: "Evolved Universal Terrestrial Access (E-UTRA); LTE Positioning Protocol A (LPPa)".
- [11] 3GPP TS 36.300: "Evolved Universal Terrestrial Radio Access (E-UTRA), Evolved Universal Terrestrial Radio Access Network (E-UTRAN); Overall description; Stage 2".
- [12] 3GPP TS 33.401: "3GPP System Architecture Evolution (SAE); Security architecture".

---

## 3 Definitions and abbreviations

### 3.1 Definitions

For the purposes of the present document, the terms and definitions given in TR 21.905 [1] and the following apply. A term defined in the present document takes precedence over the definition of the same term, if any, in TR 21.905 [1].

**Dual Connectivity:** mode of operation of a UE in RRC\_CONNECTED, configured with a Master Cell Group and a Secondary Cell Group as defined in TS 36.300 [11].

**E-RAB:** as defined in 3GPP TS 36.401 [2].

## 3.2 Abbreviations

For the purposes of the present document, the abbreviations given in TR 21.905 [1] and the following apply. An abbreviation defined in the present document takes precedence over the definition of the same abbreviation, if any, in TR 21.905 [1].

|        |                                       |
|--------|---------------------------------------|
| AS     | Access Stratum                        |
| CMAS   | Commercial Mobile Alert Service       |
| DC     | Dual Connectivity                     |
| E-RAB  | E-UTRAN Radio Access Bearer           |
| eNB    | E-UTRAN Node B                        |
| EPC    | Evolved Packet Core                   |
| EPS    | Evolved Packet System                 |
| ETWS   | Earthquake and Tsunami Warning System |
| GTP-U  | GPRS Tunnelling Protocol              |
| IP     | Internet Protocol                     |
| LTE    | Long Term Evolution                   |
| MeNB   | Master eNB                            |
| MME    | Mobility Management Entity            |
| O&M    | Operation and Maintenance             |
| PWS    | Public Warning System                 |
| QoS    | Quality of Service                    |
| RAT    | Radio Access Technology               |
| RIM    | RAN Information Management            |
| RNL    | Radio Network Layer                   |
| S1-U   | S1 User plane interface               |
| S1-MME | S1 control plane interface            |
| S-GW   | Serving Gateway                       |
| S1AP   | S1 Application Protocol               |
| SAP    | Service Access Point                  |
| SCG    | Secondary Cell Group                  |
| SeNB   | Secondary eNB                         |
| SCTP   | Stream Control Transmission Protocol  |
| TNL    | Transport Network Layer               |

## 3.3 Specification notations

For the purposes of the present document, the following notations apply:

|           |  |
|-----------|--|
| Procedure | When referring to a procedure in the specification the Procedure Name is written with the first letters in each word in upper case characters followed by the word "procedure", e.g. Radio Network Layer (RNL) procedures. |
| Message   | When referring to a message in the specification the MESSAGE NAME is written with all letters in upper case characters followed by the word "message", e.g. RADIO LINK SETUP REQUEST message.                              |

---

## 4 General aspects

This clause captures the S1 interface principles and characteristics.

## 4.1 E-UTRAN architecture

The E-UTRAN is layered into a Radio Network Layer (RNL) and a Transport Network Layer (TNL). The E-UTRAN architecture, i.e. the E-UTRAN logical nodes and interfaces between them, are defined as part of the RNL.

The E-UTRAN architecture consists of a set of eNBs connected to the EPC through the S1 interface. The overall LTE architecture and E-UTRAN architecture are described in 3GPP TS 36.401 [2]. This subclause specifies only the architecture of the S1 interface, and shall not constrain the network architecture of either core or radio access networks.

The S1 interface is specified at the boundary between the EPC and the E-UTRAN. Figure 4.1 depicts the logical division of the S1 interface. From the S1 perspective, the E-UTRAN access point is an eNB, and the EPC access point is either the control plane MME logical node or the user plane S-GW logical node. Two types of S1 interfaces are thus defined at the boundary depending on the EPC access point: S1-MME towards an MME and S1-U towards an S-GW.

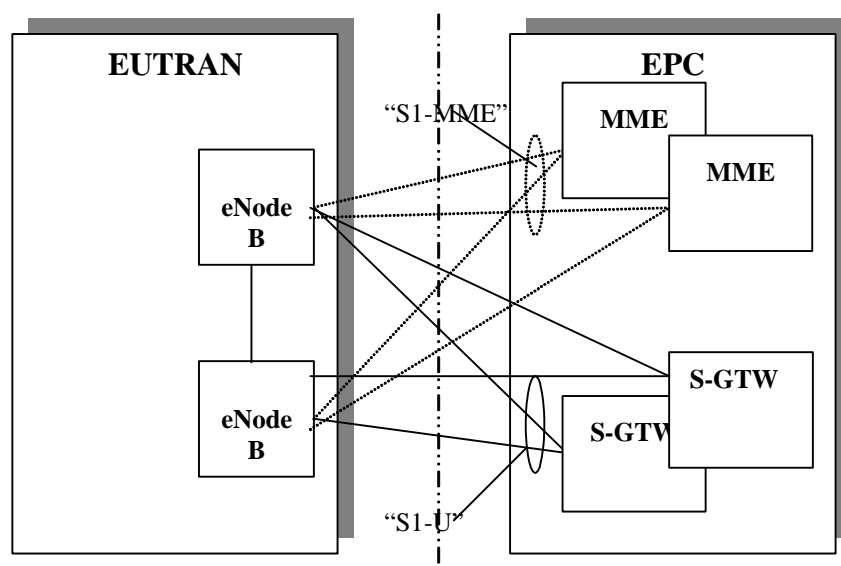

**Figure 4.1: S1 interface architecture**

The E-UTRAN may thus have several S1 access points towards the EPC. As a minimum, each S1 access point (in E-UTRAN or EPC) shall independently fulfil the requirements of the relevant S1 specifications (3GPP 36.41x series - see clause 7).

S1 is a logical interface.

There may be multiple S1-MME logical interfaces towards the EPC from any one eNB. The selection of the S1-MME interface is then determined by the NAS Node Selection function as described in clause 5.

There may be multiple S1-U logical interfaces towards the EPC from any one eNB. The selection of the S1-U interface is done within the EPC and signalled to the eNB by the MME.

## 4.2 S1 interface general principles

The general principles for the specification of the S1 interface are as follows:

- the S1 interface should be open;
- the S1 interface shall support the exchange of signalling information between the eNB and EPC;
- from a logical standpoint, the S1 is a point-to-point interface between an eNB within the E-UTRAN and an MME in the EPC. A point-to-point logical interface should be feasible even in the absence of a physical direct connection between the eNB and MME.

## 4.3 S1 interface specification objectives

The S1 interface specification shall facilitate the following:

- inter-connection of eNBs with MMEs supplied by different manufacturers;
- separation of S1 interface Radio Network functionality and Transport Network functionality to facilitate introduction of future technology.

## 4.4 S1 interface capabilities

The S1 interface supports:

- procedures to establish, maintain and release E-UTRAN Radio Access Bearers;
- procedures to perform intra-LTE handover and inter-RAT handover;
- the separation of each UE on the protocol level for user specific signalling management;
- the transfer of NAS signalling messages between UE and EPC;
- location services by transferring requests from the EPC to E-UTRAN, and location information from E-UTRAN to EPC;
- mechanisms for resource reservation for packet data streams.

## 4.5 S1 interface characteristics

### 4.5.1 Use of the Stream Control Transmission Protocol (SCTP)

The SCTP protocol (IETF RFC 4960 [7]) is used to support the exchange of S1 Application Protocol (S1AP) signalling messages between an eNB and an MME.

---

# 5 Functions of the S1 interface protocols and functional split

## 5.1 General

The following clauses describe the functions supported over S1-MME and S1-U to fulfil the S1 interface capabilities.

## 5.2 S1 UE context management function

In order to support UEs in the LTE\_ACTIVE state, UE contexts need to be managed, i.e. established and released in the eNB and in the EPC to support user individual signalling on S1. This includes security context management.

The S1 UE context management function supports the establishment of the necessary overall initial UE context including E-RAB context, security context, roaming and access restrictions, UE S1 signalling connection ID(s), etc. in the eNB to enable fast idle-to-active transition.

The establishment of the overall initial UE context is initiated by the MME.

The S1 UE context management function also supports the release of the context previously established in the eNB to enable the active-to-idle transition. The release of the context is triggered by the MME either directly or following a request received from the eNB.

## 5.3 E-RAB management functions

The E-RAB service management function is responsible for establishing, modifying and releasing E-UTRAN resources for user data transport once a UE context is available in the eNB. The establishment and modification of E-UTRAN resources is triggered by the MME and requires respective QoS information to be provided to the eNB. For Dual Connectivity when SCG bearer option is applied, the modification of the E-RAB is triggered by the MeNB towards the MME for the modification of the transport information. The release of E-UTRAN resources is triggered by the MME either directly or following a request received from the eNB (optional).

## 5.4 S1 link management function

### 5.4.1 GTP-U tunnels management function

This function is used to establish and release GTP-U (3GPP TS 29.281 [8]) tunnels between the EPC and the E-UTRAN upon an E-RAB service request. This involves assigning a tunnel identifier for each direction.

### 5.4.2 S1 signalling link management function

The S1 signalling link management function provides a reliable transfer of the radio network signalling between E-UTRAN and EPC.

## 5.5 Mobility functions for UEs in LTE\_Active

### 5.5.1 Intra-LTE handover

The Intra-LTE handover function supports mobility for UEs in LTE\_ACTIVE and comprises the preparation, execution and completion of handover via the X2 and S1 interfaces.

### 5.5.2 Inter-3GPP RAT handover

The Inter-3GPP-RAT handover function supports mobility to and from other 3GPP-RATs for UEs in LTE\_ACTIVE and comprises the preparation, execution and completion of handover via the S1 interface.

### 5.5.3 Mobility to CDMA2000 system

The mobility to non-3GPP radio system function supports mobility to and from other non-3GPP radio technologies for UEs in LTE\_ACTIVE, namely to and from CDMA2000 systems. This comprises signalling for pre-registration of UE with CDMA2000 HRPD network and signalling for handover preparation for handover from E-UTRAN to CDMA2000 HRPD/1xRTT.

## 5.6 Paging function

The paging function supports the sending of paging requests to the eNBs having one or more cells which correspond to one of the TAs in which the UE is registered.

## 5.7 Void

### 5.7a Roaming and access restriction support functions

The S1 interface supports the transfer of roaming and access restriction information from the EPC to the eNB for the UE in the network.

## 5.8 S1 interface management function

The error indication function is used by the eNB (respectively the MME) to indicate to the MME (respectively the eNB) that a logical error has occurred.

The reset function is used to initialize the peer entity after node setup and after a failure event occurred. This procedure can be used by both the eNB and MME.

The S1 setup (respectively the eNB and MME configuration update) function allows to exchange (respectively update) application level data needed for the eNB and MME to interoperate correctly on the S1 interface.

The S1 removal function allows to remove the interface between eNB and MME in a controlled manner.

## 5.9 Coordination functions

### 5.9.1 Network sharing function

The S1 interface supports the transfer of the UE's serving PLMN and of equivalent PLMNs to the serving PLMN.

### 5.9.2 NAS node selection function

The interconnection of eNBs to multiple MME / S-GWs is supported by the LTE/EPS architecture (see 3GPP TS 23.401 [9] and 3GPP TS 36.300 [11]). Therefore a NAS node selection function is located in the eNB to determine the MME association of the UE.

This functionality is located in the eNB to determine and establish an association between a given UE and one of the MME nodes that comprise the pool area the eNB belongs to.

It then enables proper routing via the S1-MME interface.

On S1, no specific procedure corresponds to the NAS node selection function.

The S1 interface supports the indication by the MME of its relative capacity to the eNB, in order to achieve load-balanced MMEs within the pool area.

When the eNB is configured to ensure that the selected MME serves the country where the UE is located, as described in TS 23.401 [9], the eNB takes into account UE location information, if available, when determining the MME.

### 5.9.3 MME overload control function

The S1 interface supports the indication by the MME of its overload situations to the eNB.

## 5.10 Security function

### 5.10.1 Data confidentiality

#### 5.10.1.1 Radio interface ciphering function

The radio interface may be ciphered. Both, signalling and user data, may be subject to ciphering. The ciphering shall be done within the E-UTRAN.

#### 5.10.1.2 Ciphering key management function

The MME provides the eNB with the key  $K_{eNB}$ , which is used for the derivation of the ciphering keys used for ciphering of the radio interface as defined in TS 36.300 [11] and TS 33.401 [12].

## 5.10.2 Data integrity

### 5.10.2.1 Integrity checking

The purpose of the integrity check is to ensure the integrity of the signalling messages over the air interface to make sure that the signalling continues between the same elements, i.e., the UE and the eNB that first established the secure connection. The integrity check shall be done within the E-UTRAN.

### 5.10.2.2 Integrity key management

The MME provides the eNB with the key  $K_{eNB}$ , which is used for the derivation of the integrity key used for the integrity protection of the radio interface control plane as defined in TS 36.300 [11] and TS 33.401 [12].

## 5.11 Service and network access function

### 5.11.1 Core network signalling data transfer function

The NAS EPC signalling data shall be transparently conveyed between the EPC and the UE. Over the S1 interface, the same S1 interface channel that is used for the E-UTRAN–EPC signalling shall be used.

### 5.11.2 UE tracing

This function allows tracing of various events related to the UE and its activities. This is an O&M functionality.

### 5.11.3 Location reporting function

The positioning function performs the determination of the geographical position of the UE.

This function allows the MME to request the eNB for a given UE either to report directly the current serving cell or to report upon change of serving cell.

If dual connectivity is configured for a specific UE, the location reported refers to the cell served by the MeNB.

### 5.11.4 LTE Positioning Protocol A (LPPa) signalling transfer function

The LPPa (3GPP TS 36.455 [10]) signalling data is transparently conveyed between the E-SMLC and the eNB.

### 5.11.5 Delivery of warning messages

This function provides the capability to start or stop the delivery of warning notification messages related to alerts (earthquake, tsunami, etc.). The messages belong to one of the independent warning services: ETWS, CMAS or the other services which use the same Access Stratum (AS) mechanisms as CMAS as described in 3GPP TS 36.300 [11].

In ETWS, the messages to be delivered can either be primary notifications which have stringent delivery delay or secondary notifications.

## 5.12 RAN Information Management (RIM) function

The RAN Information Management (RIM) function is a generic mechanism that allows the request and transfer of information (e.g. GERAN/UTRAN system information) between two RAN nodes via the Core Network (CN).

## 5.13 Configuration Transfer function

The Configuration Transfer function allows the request and transfer of RAN configuration information (e.g., SON information) between two RAN nodes via the Core Network (CN).

## 6 S1 interface protocol structure

The protocol structure is following the structure defined in 3GPP TS 36.401 [2].

### 6.1 General

The radio network signalling over S1 consists of the S1 Application Part (S1AP). The S1AP protocol consists of mechanisms to handle all procedures between the EPC and E-UTRAN. It is also capable of conveying messages transparently between the EPC and the UE without interpretation or processing by the E-UTRAN.

Over the S1 interface the S1AP protocol is, e.g., used to:

- Facilitate a set of general E-UTRAN procedures from the EPC such as paging-notification as defined by the notification Service Access Point (SAP).
- Separate each User Equipment (UE) on the protocol level for mobile specific signalling management as defined by the dedicated SAP.
- Transfer of transparent non-access signalling as defined in the dedicated SAP.
- Request of various types of E-RABs through the dedicated SAP.
- Perform the mobility function.

The E-RABs are provided by the Access Stratum (AS).

### 6.2 S1-MME

Figure 6.2-1 shows the protocol structure for S1-MME, following the structure described in 3GPP TS 36.401 [2].

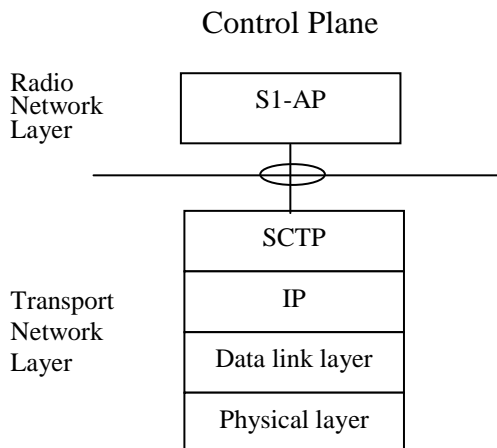
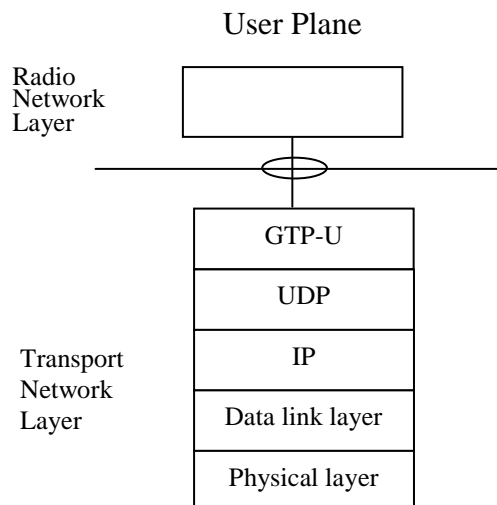

**Figure 6.2-1: Interface protocol structure for S1-MME**

The Transport Network Layer (TNL) is based on IP transport, comprising the Stream Control Transmission Protocol (SCTP) on top of IP.

## 6.3 S1-U

Figure 6.3-1 shows the protocol structure for S1-U, following the structure described in 3GPP TS 36.401 [2].



**Figure 6.3-1: Interface protocol structure for S1-U**

---

## 7 Other S1 interface specifications

This clause contains the description of the other related 3GPP specifications.

### 7.1 E-UTRAN S1 interface: layer 1 (3GPP TS 36.411)

3GPP TS 36.411 [3] specifies the physical layer technologies that may be used to support the S1 interface.

### 7.2 E-UTRAN S1 interface: signalling transport (3GPP TS 36.412)

3GPP TS 36.412 [4] specifies the signalling bearers for the S1AP for the S1-MME interface.

### 7.3 E-UTRAN S1 interface: S1AP specification (3GPP TS 36.413)

3GPP TS 36.413 [5] specifies the S1AP protocol for radio network control plane signalling over the S1 interface.

### 7.4 E-UTRAN S1 interface: data transport and transport signalling (3GPP TS 36.414)

3GPP TS 36.414 [6] specifies the transport bearers for the user plane of the S1-U interface.

## Annex A (informative): Change history

| TSG #   | TSG Doc.  | CR   | Rev | Subject/Comment  | New    |
|---------|-----------|------|-----|--|--------|
| RP-38   |           |      |     | Specification approved at TSG-RAN 38 and placed under change control   | 8.0.0  |
| RP-42   | RP-080845 | 0001 |     | Correction of SAE Bearers  | 8.1.0  |
| RP-42   | RP-080844 | 0002 | 1   | Rapporteurs update of TS36.410   | 8.1.0  |
| RP-42   | RP-080844 | 0003 | 1   | RIM support in E-UTRAN   | 8.1.0  |
| RP-43   | RP-090090 | 0004 | 2   | Paging function clarification in E-UTRAN CR36.410                      | 8.2.0  |
| RP-46   | RP-091189 | 0007 | 1   | CR for Transportation support for LPPa                                 | 9.0.0  |
| RP-48   | RP-100599 | 0010 | 2   | Handling of CMAS and ETWS  | 9.1.0  |
| RP-48   | RP-100592 | 0011 | 1   | Clean-up of TS36.410   | 9.1.0  |
| 12/2010 |           |      |     | Created Rel-10 version based on v 9.1.0                                | 10.0.0 |
| SP-49   | SP-100629 |      |     | Clarification on the use of References (TS 21.801 CR#0030)             | 10.0.1 |
| RP-52   | RP-110688 | 0014 | 3   | Clarification on roaming and area restriction function                 | 10.1.0 |
| RP-52   | RP-110684 | 0015 |     | Correction of References   | 10.1.0 |
| RP-53   | RP-111196 | 0017 | 1   | Miscellaneous updates  | 10.2.0 |
| RP-56   | RP-120744 | 0019 | 1   | Introduction of KPAS delivery function                                 | 10.3.0 |
| 09/2012 |           |      |     | Update to Rel-11 version (MCC)   | 11.0.0 |
| RP-61   | RP-131183 | 0022 | 1   | Correction of terminology concerning the mobility restriction function | 11.1.0 |
| 09/2013 |           |      |     | MCC cleanup  | 11.1.0 |
| 09/2014 |           |      |     | Update to Rel-12 version (MCC)   | 12.0.0 |
| RP-66   | RP-142089 | 0023 | 2   | Introduction of Dual Connectivity                                      | 12.1.0 |
| RP-66   | RP-142093 | 0024 | 3   | Correction on security functions                                       | 12.1.0 |
| 12/2015 |           |      |     | Update to Rel-13 version (MCC)   | 13.0.0 |

| Change history |          |           |      |     |     |   |             |
|----------------|----------|-----------|------|-----|-----|---|-------------|
| Date           | Meeting  | TDoc      | CR   | Rev | Cat | Subject/Comment   | New version |
| 2017-03        | SA#75    |           |      |     |     | Promotion to Release 14 without technical change          | 14.0.0      |
| 2018-06        | SA#80    | -         | -    | -   | -   | Promotion to Release 15 without technical change          | 15.0.0      |
| 2020-07        | SA#88-e  | -         | -    | -   | -   | Update to Rel-16 version (MCC)                            | 16.0.0      |
| 2022-03        | RAN#95-e | RP-220216 | 0028 | 3   | C   | NNSF for IoT NTN providing access over multiple countries | 17.0.0      |
| 2024-03        | SA#103-  | -         | -    | -   | -   | Update to Rel-18 version (MCC)                            | 18.0.0      |
| 2025-09        | RAN#109  | RP-252688 | 0031 | 3   | B   | Support of Full eNB as Regenerative payload               | 19.0.0      |

---

# History

| <b>Document history</b> |              |             |
|-------------------------|--------------|-------------|
| V19.0.0                 | January 2026 | Publication |
|                         |              |             |
|                         |              |             |
|                         |              |             |
|                         |              |             |