

# ETSI TS 137 105 V17.12.0 (2025-10)



**Universal Mobile Telecommunications System (UMTS);  
LTE;  
5G;  
Active Antenna System (AAS) Base Station (BS)  
transmission and reception  
(3GPP TS 37.105 version 17.12.0 Release 17)**



---

**Reference**RTS/TSGR-0437105vhc0

---

**Keywords**5G,LTE,UMTS

---

**ETSI**

650 Route des Lucioles  
F-06921 Sophia Antipolis Cedex - FRANCE

---

Tel.: +33 4 92 94 42 00 Fax: +33 4 93 65 47 16

Siret N° 348 623 562 00017 - APE 7112B  
Association à but non lucratif enregistrée à la  
Sous-Préfecture de Grasse (06) N° w061004871

---

**Important notice**

---

The present document can be downloaded from the  
[ETSI Search & Browse Standards application](#).

The present document may be made available in electronic versions and/or in print. The content of any electronic and/or print versions of the present document shall not be modified without the prior written authorization of ETSI. In case of any existing or perceived difference in contents between such versions and/or in print, the prevailing version of an ETSI deliverable is the one made publicly available in PDF format on [ETSI deliver repository](#).

Users should be aware that the present document may be revised or have its status changed, this information is available in the [Milestones listing](#).

If you find errors in the present document, please send your comments to the relevant service listed under [Committee Support Staff](#).

If you find a security vulnerability in the present document, please report it through our [Coordinated Vulnerability Disclosure \(CVD\)](#) program.

---

**Notice of disclaimer & limitation of liability**

---

The information provided in the present deliverable is directed solely to professionals who have the appropriate degree of experience to understand and interpret its content in accordance with generally accepted engineering or other professional standard and applicable regulations.

No recommendation as to products and services or vendors is made or should be implied.

No representation or warranty is made that this deliverable is technically accurate or sufficient or conforms to any law and/or governmental rule and/or regulation and further, no representation or warranty is made of merchantability or fitness for any particular purpose or against infringement of intellectual property rights.

In no event shall ETSI be held liable for loss of profits or any other incidental or consequential damages.

Any software contained in this deliverable is provided "AS IS" with no warranties, express or implied, including but not limited to, the warranties of merchantability, fitness for a particular purpose and non-infringement of intellectual property rights and ETSI shall not be held liable in any event for any damages whatsoever (including, without limitation, damages for loss of profits, business interruption, loss of information, or any other pecuniary loss) arising out of or related to the use of or inability to use the software.

---

**Copyright Notification**

---

No part may be reproduced or utilized in any form or by any means, electronic or mechanical, including photocopying and microfilm except as authorized by written permission of ETSI.

The content of the PDF version shall not be modified without the written authorization of ETSI.

The copyright and the foregoing restriction extend to reproduction in all media.

© ETSI 2025.  
All rights reserved.

---

# Intellectual Property Rights

## Essential patents

IPRs essential or potentially essential to normative deliverables may have been declared to ETSI. The declarations pertaining to these essential IPRs, if any, are publicly available for **ETSI members and non-members**, and can be found in ETSI SR 000 314: "*Intellectual Property Rights (IPRs); Essential, or potentially Essential, IPRs notified to ETSI in respect of ETSI standards*", which is available from the ETSI Secretariat. Latest updates are available on the [ETSI IPR online database](#).

Pursuant to the ETSI Directives including the ETSI IPR Policy, no investigation regarding the essentiality of IPRs, including IPR searches, has been carried out by ETSI. No guarantee can be given as to the existence of other IPRs not referenced in ETSI SR 000 314 (or the updates on the ETSI Web server) which are, or may be, or may become, essential to the present document.

## Trademarks

The present document may include trademarks and/or tradenames which are asserted and/or registered by their owners. ETSI claims no ownership of these except for any which are indicated as being the property of ETSI, and conveys no right to use or reproduce any trademark and/or tradename. Mention of those trademarks in the present document does not constitute an endorsement by ETSI of products, services or organizations associated with those trademarks.

**DECT™**, **PLUGTESTS™**, **UMTS™** and the ETSI logo are trademarks of ETSI registered for the benefit of its Members. **3GPP™**, **LTE™** and **5G™** logo are trademarks of ETSI registered for the benefit of its Members and of the 3GPP Organizational Partners. **oneM2M™** logo is a trademark of ETSI registered for the benefit of its Members and of the oneM2M Partners. **GSM®** and the GSM logo are trademarks registered and owned by the GSM Association.

---

# Legal Notice

This Technical Specification (TS) has been produced by ETSI 3rd Generation Partnership Project (3GPP).

The present document may refer to technical specifications or reports using their 3GPP identities. These shall be interpreted as being references to the corresponding ETSI deliverables.

The cross reference between 3GPP and ETSI identities can be found at [3GPP to ETSI numbering cross-referencing](#).

---

# Modal verbs terminology

In the present document "**shall**", "**shall not**", "**should**", "**should not**", "**may**", "**need not**", "**will**", "**will not**", "**can**" and "**cannot**" are to be interpreted as described in clause 3.2 of the [ETSI Drafting Rules](#) (Verbal forms for the expression of provisions).

"**must**" and "**must not**" are **NOT** allowed in ETSI deliverables except when used in direct citation.

# Contents

Intellectual Property Rights .....	2
Legal Notice .....	2
Modal verbs terminology.....	2
Foreword.....	12
1 Scope .....	14
2 References .....	14
3 Definitions, symbols and abbreviations .....	16
3.1 Definitions .....	16
3.2 Symbols.....	20
3.3 Abbreviations .....	21
4 General .....	22
4.1 Relationship between the AAS BS specification and non-AAS BS single RAT & MSR specifications .....	22
4.2 Relationship between minimum requirements and test requirements .....	23
4.3 Conducted and radiated requirement reference points .....	23
4.4 Base station classes for AAS BS .....	24
4.5 Regional requirements.....	25
4.6 Operating Bands and Band Categories .....	27
4.7 Channel arrangements .....	27
4.8 Requirements for contiguous and non-contiguous spectrum.....	27
4.9 Requirements for AAS BS capable of operation in multiple operating bands .....	27
4.10 OTA Co-location with other base stations .....	28
5 Applicability of Requirements .....	29
5.1 General .....	29
5.2 Band category 1 (BC1) and band category 2 (BC2).....	30
5.3 Band category 3 (BC3).....	33
6 Conducted transmitter characteristics .....	35
6.1 General .....	35
6.2 Base station output power .....	36
6.2.1 General.....	36
6.2.2 Maximum output power.....	36
6.2.2.1 General .....	36
6.2.2.2 Minimum requirement for MSR operation .....	37
6.2.2.2.1 General .....	37
6.2.2.2.2 Additional requirements (regional).....	37
6.2.2.3 Minimum requirement for single RAT UTRA operation.....	37
6.2.2.4 Minimum requirement for single RAT E-UTRA operation.....	37
6.2.2.4.1 General .....	37
6.2.2.4.2 Additional requirements (regional).....	37
6.2.3 UTRA FDD primary CPICH power .....	37
6.2.3.1 General .....	37
6.2.3.2 Minimum requirement for MSR operation .....	37
6.2.3.3 Minimum requirement for single RAT UTRA operation.....	37
6.2.3.4 Minimum requirement for single RAT E-UTRA operation.....	38
6.2.4 UTRA TDD primary CCPCH power.....	38
6.2.4.1 General .....	38
6.2.4.2 Minimum requirement for MSR operation .....	38
6.2.4.3 Minimum requirement for single RAT UTRA operation.....	38
6.2.4.4 Minimum requirement for single RAT E-UTRA operation.....	39
6.2.5 UTRA FDD additional CPICH power for MIMO mode .....	39
6.2.5.1 General .....	39
6.2.5.2 Minimum requirement for MSR operation .....	39
6.2.5.3 Minimum requirement for single RAT UTRA operation.....	39

6.2.5.4	Minimum requirement for single RAT E-UTRA operation.....	40
6.2.6	E-UTRA DL RS power.....	40
6.2.6.1	General.....	40
6.2.6.2	Minimum requirement for MSR operation.....	41
6.2.6.3	Minimum requirement for single RAT UTRA operation.....	41
6.2.6.4	Minimum requirement for single RAT E-UTRA operation.....	41
6.3	Output power dynamics.....	41
6.3.1	General.....	41
6.3.2	UTRA Inner loop power control in the downlink.....	41
6.3.2.1	General.....	41
6.3.2.2	Minimum requirement for MSR operation.....	41
6.3.2.3	Minimum requirement for single RAT UTRA operation.....	41
6.3.2.4	Minimum requirement for single RAT E-UTRA operation.....	42
6.3.3	Power control dynamic range.....	42
6.3.3.1	General.....	42
6.3.3.2	Minimum requirement for MSR operation.....	42
6.3.3.3	Minimum requirement for single RAT UTRA operation.....	42
6.3.3.4	Minimum requirement for single RAT E-UTRA operation.....	43
6.3.4	Total power dynamic range.....	43
6.3.4.1	General.....	43
6.3.4.2	Minimum requirement for MSR operation.....	43
6.3.4.3	Minimum requirement for single RAT UTRA operation.....	43
6.3.4.4	Minimum requirement for single RAT E-UTRA operation.....	43
6.3.5	IPDL time mask.....	43
6.3.5.1	General.....	43
6.3.5.2	Minimum requirement for MSR operation.....	44
6.3.5.3	Minimum requirement for single RAT UTRA operation.....	44
6.3.5.4	Minimum requirement for single RAT E-UTRA operation.....	44
6.3.6	RE Power control dynamic range.....	44
6.3.6.1	General.....	44
6.3.6.2	Minimum requirement for MSR operation.....	44
6.3.6.3	Minimum requirement for single RAT UTRA operation.....	44
6.3.6.4	Minimum requirement for single RAT E-UTRA operation.....	44
6.4	Transmit ON/OFF power.....	44
6.4.1	General.....	44
6.4.2	Transmitter OFF power.....	45
6.4.2.1	General.....	45
6.4.2.2	Minimum requirement for MSR operation.....	45
6.4.2.3	Minimum requirement for single RAT UTRA operation.....	45
6.4.2.4	Minimum requirement for single RAT E-UTRA operation.....	45
6.4.3	Transmitter transient period.....	45
6.4.3.1	General.....	45
6.4.3.2	Minimum requirement for MSR operation.....	46
6.4.3.3	Minimum requirement for single RAT UTRA operation.....	46
6.4.3.4	Minimum requirement for single RAT E-UTRA operation.....	46
6.5	Transmitted signal quality.....	46
6.5.1	General.....	46
6.5.2	Frequency Error.....	46
6.5.2.1	General.....	46
6.5.2.2	Minimum requirement for MSR operation.....	46
6.5.2.3	Minimum requirement for single RAT UTRA operation.....	47
6.5.2.4	Minimum requirement for single RAT E-UTRA operation.....	47
6.5.3	Time alignment error.....	47
6.5.3.1	General.....	47
6.5.3.2	Minimum requirement for MSR operation.....	47
6.5.3.3	Minimum requirement for single RAT UTRA operation.....	48
6.5.3.4	Minimum requirement for single RAT E-UTRA operation.....	48
6.5.4	Modulation quality.....	48
6.5.4.1	General.....	48
6.5.4.2	Minimum requirement for MSR operation.....	48
6.5.4.3	Minimum requirement for single RAT UTRA operation.....	48
6.5.4.4	Minimum requirement for single RAT E-UTRA operation.....	49

6.5.5	Transmit pulse shape filter.....	49
6.5.5.1	General.....	49
6.5.5.2	Void.....	49
6.5.5.3	Void.....	49
6.5.5.4	Void.....	49
6.6	Unwanted Emissions.....	49
6.6.1	General.....	49
6.6.2	Occupied bandwidth.....	50
6.6.2.1	General.....	50
6.6.2.2	Minimum requirement for MSR operation.....	50
6.6.2.3	Minimum requirement for single RAT UTRA operation.....	50
6.6.2.4	Minimum requirement for single RAT E-UTRA operation.....	50
6.6.3	Adjacent Channel Leakage power Ratio.....	51
6.6.3.1	General.....	51
6.6.3.2	Minimum requirement for MSR operation.....	51
6.6.3.3	Minimum requirement for single RAT UTRA operation.....	52
6.6.3.4	Minimum requirement for single RAT E-UTRA operation.....	52
6.6.4	Spectrum emission mask.....	52
6.6.4.1	General.....	52
6.6.4.2	Minimum requirement for MSR operation.....	52
6.6.4.3	Minimum requirement for single RAT UTRA operation.....	52
6.6.4.3.1	General.....	52
6.6.4.3.2	Basic limits for single RAT UTRA FDD operation.....	52
6.6.4.3.3	Basic limits for single RAT UTRA TDD 1,28Mcps operation.....	58
6.6.4.4	Minimum requirement for single RAT E-UTRA operation.....	60
6.6.5	Operating band unwanted emission.....	60
6.6.5.1	General.....	60
6.6.5.2	Minimum requirement for MSR operation.....	60
6.6.5.2.1	General.....	60
6.6.5.2.2	<i>Basic limits</i> for Band Categories 1 and 3.....	61
6.6.5.2.3	<i>Basic limit</i> for Band Category 2.....	66
6.6.5.2.4	Additional requirements.....	74
6.6.5.3	Minimum requirement for single RAT UTRA operation.....	74
6.6.5.4	Minimum requirement for single RAT E-UTRA operation.....	74
6.6.5.4.1	General.....	74
6.6.5.4.2	Basic limits for Wide Area BS (Category A).....	76
6.6.5.4.3	Basic limits for Wide Area BS (Category B).....	78
6.6.5.4.3.1	General.....	78
6.6.5.4.3.2	Category B requirements (Option 1).....	78
6.6.5.4.3.3	Category B (Option 2).....	81
6.6.5.4.4	Basic limits for Local Area BS (Category A and B).....	83
6.6.5.4.5	Basic limits for Medium Range BS (Category A and B).....	84
6.6.5.4.7	Additional requirements.....	86
6.6.6	Spurious emission.....	86
6.6.6.1	General.....	86
6.6.6.2	Minimum requirement for MSR operation.....	87
6.6.6.3	Minimum requirement for single RAT UTRA operation.....	87
6.6.6.4	Minimum requirement for single RAT E-UTRA operation.....	88
6.7	Transmitter intermodulation.....	88
6.7.1	General.....	88
6.7.2	Minimum requirement for MSR operation.....	88
6.7.2.1	General co-location minimum requirement.....	88
6.7.2.2	Additional co-location minimum requirement (BC1 and BC2).....	89
6.7.2.3	Additional co-location minimum requirement (BC3).....	90
6.7.2.4	Additional co-location minimum requirements.....	90
6.7.2.5	Intra-system minimum requirement.....	90
6.7.3	Minimum requirement for single RAT UTRA operation.....	91
6.7.3.1	General co-location minimum requirement for FDD UTRA.....	91
6.7.3.2	General co-location minimum requirement for 1,28 Mcps TDD UTRA.....	91
6.7.3.3	Intra-system minimum requirement.....	92
6.7.4	Minimum requirement for single RAT E-UTRA operation.....	92
6.7.4.1	General co-location minimum requirement.....	92

6.7.4.2	Void.....	93
6.7.4.3	Intra-system minimum requirement .....	93
7	Conducted receiver characteristics .....	94
7.1	General .....	94
7.2	Reference sensitivity level.....	95
7.2.1	General.....	95
7.2.2	Minimum requirement for MSR operation .....	95
7.2.3	Minimum requirement for single RAT UTRA operation .....	95
7.2.4	Minimum requirement for single RAT E-UTRA operation.....	95
7.3	Dynamic range .....	95
7.3.1	General.....	95
7.3.2	Minimum requirement for MSR operation .....	96
7.3.3	Minimum requirement for single RAT UTRA operation .....	96
7.3.4	Minimum requirement for single RAT E-UTRA operation.....	96
7.4	Adjacent channel selectivity, general blocking, and narrowband blocking.....	96
7.4.1	General.....	96
7.4.2	Minimum requirement for MSR operation .....	97
7.4.2.1	General minimum requirement .....	97
7.4.2.2	General narrowband blocking minimum requirement .....	98
7.4.2.3	Additional BC3 blocking minimum requirement.....	99
7.4.3	Minimum requirement for single RAT UTRA operation .....	100
7.4.4	Minimum requirement for single RAT E-UTRA operation.....	100
7.5	Blocking .....	100
7.5.1	General.....	100
7.5.2	Minimum requirement for MSR operation .....	100
7.5.2.1	General minimum requirement .....	100
7.5.2.2	Co-location minimum requirement .....	101
7.5.3	Minimum requirement for single RAT UTRA operation .....	106
7.5.3.1	General minimum requirement .....	106
7.5.3.2	Co-location minimum requirement .....	106
7.5.4	Minimum requirement for single RAT E-UTRA operation.....	107
7.5.4.1	General minimum requirement .....	107
7.5.4.2	Co-location minimum requirement .....	111
7.6	Receiver spurious emissions.....	111
7.6.1	General.....	111
7.6.2	Minimum requirement for MSR operation .....	112
7.6.2.1	General minimum requirement .....	112
7.6.3	Minimum requirement for single RAT UTRA operation .....	112
7.6.4	Minimum requirement for single RAT E-UTRA operation.....	113
7.7	Receiver intermodulation .....	113
7.7.1	General.....	113
7.7.2	Minimum requirement for MSR operation .....	113
7.7.2.1	General intermodulation minimum requirement.....	113
7.7.2.2	General narrowband intermodulation minimum requirement.....	115
7.7.3	Minimum requirement for single RAT UTRA operation .....	119
7.7.4	Minimum requirement for single RAT E- UTRA operation.....	119
7.8	In-channel selectivity .....	119
7.8.1	General.....	119
7.8.2	Minimum requirement for MSR operation .....	119
7.8.3	Minimum requirement for single RAT UTRA operation .....	119
7.8.4	Minimum requirement for single RAT E-UTRA operation.....	120
8	Performance requirements.....	120
8.1	General .....	120
8.1.1	UTRA operation .....	120
8.1.2	E-UTRA operation.....	121
8.2	Minimum requirements for MSR operation .....	122
8.3	Minimum requirements for UTRA operation.....	122
8.4	Minimum requirements for E-UTRA operation .....	122
9	Radiated transmitter characteristics.....	122
9.1	General .....	122

9.2	Radiated transmit power.....	123
9.2.1	General.....	123
9.2.2	Minimum requirement for MSR operation.....	123
9.2.3	Minimum requirement for single RAT UTRA operation.....	123
9.2.4	Minimum requirement for single RAT E-UTRA operation.....	123
9.3	OTA Base Station output power.....	124
9.3.1	General.....	124
9.3.2	OTA Maximum output power.....	124
9.3.2.1	General.....	124
9.3.2.2	Minimum requirement for MSR operation.....	124
9.3.2.2.1	General.....	124
9.3.2.2.2	Additional requirements (regional).....	124
9.3.2.3	Minimum requirement for single RAT UTRA operation.....	124
9.3.2.4	Minimum requirement for single RAT E-UTRA operation.....	124
9.3.2.4.1	General.....	124
9.3.2.4.2	Additional requirements (regional).....	125
9.3.3	OTA E-UTRA DL RS power.....	125
9.3.3.1	General.....	125
9.3.3.2	Minimum requirement for MSR operation.....	125
9.3.3.3	Minimum requirement for single RAT UTRA operation.....	125
9.3.3.4	Minimum requirement for single RAT E-UTRA operation.....	125
9.4	OTA Output power dynamics.....	125
9.4.1	General.....	125
9.4.2	OTA UTRA Inner loop power control in the downlink.....	125
9.4.2.1	General.....	125
9.4.2.2	Minimum requirement for MSR operation.....	125
9.4.2.3	Minimum requirement for single RAT UTRA operation.....	126
9.4.2.4	Minimum requirement for single RAT E-UTRA operation.....	126
9.4.3	OTA Power control dynamic range.....	126
9.4.3.1	General.....	126
9.4.3.2	Minimum requirement for MSR operation.....	126
9.4.3.3	Minimum requirement for single RAT UTRA operation.....	126
9.4.3.4	Minimum requirement for single RAT E-UTRA operation.....	127
9.4.4	OTA Total power dynamic range.....	127
9.4.4.1	General.....	127
9.4.4.2	Minimum requirement for MSR operation.....	127
9.4.4.3	Minimum requirement for single RAT UTRA operation.....	127
9.4.4.4	Minimum requirement for single RAT E-UTRA operation.....	127
9.4.5	OTA IPDL time mask.....	128
9.4.5.1	General.....	128
9.4.5.2	Minimum requirement for MSR operation.....	128
9.4.5.3	Minimum requirement for single RAT UTRA operation.....	128
9.4.5.4	Minimum requirement for single RAT E-UTRA operation.....	128
9.4.6	OTA RE Power control dynamic range.....	128
9.4.6.1	General.....	128
9.4.6.2	Minimum requirement for MSR operation.....	129
9.4.6.3	Minimum requirement for single RAT UTRA operation.....	129
9.4.6.4	Minimum requirement for single RAT E-UTRA operation.....	129
9.5	OTA Transmit ON/OFF power.....	129
9.5.1	General.....	129
9.5.2	OTA Transmitter OFF power.....	129
9.5.2.1	General.....	129
9.5.2.2	Minimum requirement for MSR operation.....	130
9.5.2.3	Minimum requirement for single RAT UTRA operation.....	130
9.5.2.4	Minimum requirement for single RAT E-UTRA operation.....	130
9.5.3	OTA Transmitter transient period.....	130
9.5.3.1	General.....	130
9.5.3.2	Minimum requirement for MSR operation.....	130
9.5.3.3	Minimum requirement for single RAT UTRA operation.....	131
9.5.3.4	Minimum requirement for single RAT E-UTRA operation.....	131
9.6	OTA Transmitted signal quality.....	131
9.6.1	General.....	131

9.6.2	OTA Frequency Error.....	131
9.6.2.1	General.....	131
9.6.2.2	Minimum requirement for MSR operation.....	131
9.6.2.3	Minimum requirement for single RAT UTRA operation.....	131
9.6.2.4	Minimum requirement for single RAT E-UTRA operation.....	131
9.6.3	OTA Time alignment error.....	132
9.6.3.1	General.....	132
9.6.3.2	Minimum requirement for MSR operation.....	132
9.6.3.3	Minimum requirement for single RAT UTRA operation.....	132
9.6.3.4	Minimum requirement for single RAT E-UTRA operation.....	132
9.6.4	OTA Modulation quality.....	133
9.6.4.1	General.....	133
9.6.4.2	Minimum requirement for MSR operation.....	133
9.6.4.3	Minimum requirement for single RAT UTRA operation.....	133
9.6.4.4	Minimum requirement for single RAT E-UTRA operation.....	133
9.6.5	OTA Transmit pulse shape filter.....	133
9.6.5.1	General.....	133
9.7	OTA Unwanted Emissions.....	134
9.7.1	General.....	134
9.7.2	OTA occupied bandwidth.....	134
9.7.2.1	General.....	134
9.7.2.2	Minimum requirement for MSR operation.....	135
9.7.2.3	Minimum requirement for single RAT UTRA operation.....	135
9.7.2.4	Minimum requirement for single RAT E-UTRA operation.....	135
9.7.3	OTA Adjacent Channel Leakage power Ratio.....	135
9.7.3.1	General.....	135
9.7.3.2	Minimum requirement for MSR operation.....	135
9.7.3.3	Minimum requirement for single RAT UTRA operation.....	136
9.7.3.4	Minimum requirement for single RAT E-UTRA operation.....	136
9.7.4	OTA Spectrum emission mask.....	137
9.7.4.1	General.....	137
9.7.4.2	Minimum requirement for MSR operation.....	137
9.7.4.3	Minimum requirement for single RAT UTRA operation.....	137
9.7.4.3.1	General.....	137
9.7.4.3.2	Minimum requirements for single RAT UTRA FDD operation.....	137
9.7.4.4	Minimum requirement for single RAT E-UTRA operation.....	143
9.7.5	OTA Operating band unwanted emission.....	143
9.7.5.1	General.....	143
9.7.5.2	Minimum requirement for MSR operation.....	144
9.7.5.2.1	General.....	144
9.7.5.2.2	Minimum requirements for Band Categories 1 and 3.....	144
9.7.5.2.3	<i>Minimum requirement</i> for Band Category 2.....	149
9.7.5.2.4	Additional requirements.....	155
9.7.5.2.4.1	Limits in FCC Title 47.....	155
9.7.5.2.4.2	Unsynchronized operation for BC3.....	155
9.7.5.2.4.3	Protection of DTT.....	156
9.7.5.2.4.4	Void.....	156
9.7.5.2.4.5	Co-existence with RNSS/GPS services in North America.....	156
9.7.5.2.4.6	Void.....	157
9.7.5.2.4.7	Additional band 32, 50, 51, 74, 75 and 76 unwanted emissions.....	157
9.7.5.2.4.8	Additional requirements for band 45.....	158
9.7.5.2.4.9	Additional requirements for band 48.....	158
9.7.5.2.4.10	Additional requirements for band 53.....	159
9.7.5.3	Minimum requirement for single RAT UTRA operation.....	159
9.7.5.4	Minimum requirement for single RAT E-UTRA operation.....	159
9.7.5.4.1	General.....	159
9.7.5.4.2	Minimum requirements for Wide Area BS (Category A).....	160
9.7.5.4.3	Minimum requirements for Wide Area BS (Category B).....	162
9.7.5.4.3.1	General.....	162
9.7.5.4.3.2	Category B requirements (Option 1).....	162
9.7.5.4.3.3	Category B requirements (Option 2).....	165
9.7.5.4.4	Minimum requirements for Local Area BS (Category A and B).....	167

9.7.5.4.5	Minimum requirements for Medium Range BS (Category A and B).....	168
9.7.5.4.6	Additional requirements .....	171
9.7.5.4.6.1	Additional operating band unwanted emission limits for E-UTRA bands .....	171
9.7.5.4.6.2	Protection of DTT.....	172
9.7.5.4.6.3	Co-existence with RNSS/GPS services in North America .....	172
9.7.5.4.6.4	Void .....	173
9.7.5.4.6.5	Additional band 32, 50, 51, 74, 75 and 76 unwanted emissions .....	173
9.7.5.4.6.6	Additional requirements for band 45 .....	174
9.7.5.4.6.7	Additional requirements for band 48 .....	175
9.7.6	OTA Spurious emission.....	175
9.7.6.1	General .....	175
9.7.6.2	MSR operation .....	176
9.7.6.2.1	Minimum requirement for MSR operation.....	176
9.7.6.2.1.1	Minimum requirement (Category A) .....	176
9.7.6.2.1.2	Minimum requirement (Category B) .....	176
9.7.6.2.1.3	(void).....	176
9.7.6.2.2	Protection of the BS receiver of own or different BS .....	176
9.7.6.2.3	Additional spurious emissions requirements .....	177
9.7.6.2.4	Co-location with other base stations.....	177
9.7.6.3	Minimum requirement for single RAT UTRA operation.....	177
9.7.6.3.1	Mandatory Requirements .....	177
9.7.6.3.1.1	Minimum requirement (Category A) .....	177
9.7.6.3.1.2	Minimum requirement (Category B) .....	177
9.7.6.3.2	Protection of the BS receiver of own or different BS .....	178
9.7.6.3.3	Additional spurious emissions requirements .....	179
9.7.6.3.4	Co-location with other base stations.....	186
9.7.6.3.4.1	General.....	186
9.7.6.3.4.2	Minimum Requirement.....	187
9.7.6.4	Minimum requirement for single RAT E-UTRA operation.....	193
9.7.6.4.1	Mandatory Requirements .....	193
9.7.6.4.1.1	Minimum requirement (Category A) .....	193
9.7.6.4.1.2	Minimum Requirement (Category B).....	194
9.7.6.4.2	Protection of the BS receiver of own or different BS .....	194
9.7.6.4.3	Additional spurious emissions requirements .....	194
9.7.6.4.3.1	General.....	194
9.7.6.4.3.2	Minimum Requirement.....	195
9.7.6.4.4	Co-location with other base stations.....	206
9.7.6.4.4.1	General.....	206
9.7.6.4.4.2	Minimum Requirement.....	206
9.8	OTA Transmitter intermodulation.....	213
9.8.1	General.....	213
9.8.2	Minimum requirement for MSR operation .....	213
9.8.2.1	General minimum requirement .....	213
9.8.2.2	Additional minimum requirement (BC1 and BC2).....	214
9.8.2.3	Additional minimum requirement (BC3).....	215
9.8.2.4	Additional minimum requirements .....	215
9.8.3	Minimum requirement for single RAT UTRA operation .....	215
9.8.3.1	General minimum requirement for FDD UTRA .....	215
9.8.4	Minimum requirement for single RAT E-UTRA operation.....	216
9.8.4.1	General minimum requirement .....	216
9.8.4.2	Void.....	217
10	Radiated receiver characteristics .....	217
10.1	General .....	217
10.2	OTA sensitivity .....	218
10.2.1	General.....	218
10.2.2	Minimum requirement for MSR operation .....	218
10.2.3	Minimum requirement for single RAT UTRA operation .....	218
10.2.4	Minimum requirement for single RAT E-UTRA operation.....	219
10.3	OTA Reference sensitivity level .....	219
10.3.1	General.....	219
10.3.2	Minimum requirement for MSR operation .....	219

10.3.3	Minimum requirement for single RAT UTRA operation .....	220
10.3.4	Minimum requirement for single RAT E-UTRA operation.....	220
10.4	OTA Dynamic range .....	221
10.4.1	General .....	221
10.4.2	Minimum requirement for MSR operation .....	221
10.4.3	Minimum requirement for single RAT UTRA operation.....	221
10.4.4	Minimum requirement for single RAT E-UTRA operation.....	222
10.5	OTA Adjacent channel selectivity, general blocking, and narrowband blocking.....	224
10.5.1	General.....	224
10.5.2	Minimum requirement for MSR operation .....	225
10.5.2.1	General minimum requirement .....	225
10.5.2.2	General narrowband blocking minimum requirement .....	226
10.5.2.3	Additional BC3 blocking minimum requirement.....	227
10.5.3	Minimum requirement for single RAT UTRA operation .....	228
10.5.3.1	General.....	228
10.5.3.2	Minimum requirement .....	228
10.5.3.3	Minimum requirement - Co-location with UTRA-TDD.....	228
10.5.4	Minimum requirement for single RAT E-UTRA operation.....	229
10.5.4.1	General.....	229
10.5.4.2	Minimum requirement .....	229
10.6	OTA Blocking .....	231
10.6.1	General.....	231
10.6.2	Minimum requirement for MSR operation .....	232
10.6.2.1	General minimum requirement .....	232
10.6.2.2	Co-location minimum requirement .....	232
10.6.3	Minimum requirement for single RAT UTRA operation .....	237
10.6.3.1	General minimum requirement .....	237
10.6.3.2	Co-location minimum requirement .....	238
10.6.4	Minimum requirement for single RAT E-UTRA operation.....	243
10.6.4.1	General minimum requirement .....	243
10.6.4.2	Co-location minimum requirement .....	244
10.7	OTA Receiver spurious emissions .....	249
10.7.1	General.....	249
10.7.2	Minimum requirement for MSR operation .....	249
10.7.2.1	General minimum requirement.....	249
10.7.3	Minimum requirement for single RAT UTRA operation .....	249
10.7.4	Minimum requirement for single RAT E-UTRA operation.....	249
10.8	OTA Receiver intermodulation .....	250
10.8.1	General.....	250
10.8.2	Minimum requirement for MSR operation .....	250
10.8.2.1	General intermodulation minimum requirement.....	250
10.8.2.2	General narrowband intermodulation minimum requirement.....	252
10.8.3	Minimum requirement for single RAT UTRA operation .....	256
10.8.4	Minimum requirement for single RAT E- UTRA operation.....	257
10.9	OTA In-channel selectivity .....	261
10.9.1	General.....	261
10.9.2	Minimum requirement for MSR operation .....	261
10.9.3	Minimum requirement for single RAT UTRA operation .....	262
10.9.4	Minimum requirement for single RAT E- UTRA operation.....	262
11	Radiated performance requirements.....	263
11.1	General .....	263
11.1.1	OTA demodulation branches .....	263
11.1.2	UTRA operation .....	263
11.1.3	E-UTRA operation.....	264
11.2	Minimum requirements for MSR operation .....	265
11.3	Minimum requirements for UTRA operation.....	265
11.4	Minimum requirements for E-UTRA operation.....	265

**Annex A (normative): Environmental requirements for the BS equipment.....266**

**Annex B (Informative): Calculation of EIRP based on fixed assumption of passive antenna gain .....267**

B.1 Calculation of EIRP based on fixed assumption of passive antenna gain .....267

**Annex C (informative): Change history .....268**

History .....273

---

# Foreword

This Technical Specification has been produced by the 3rd Generation Partnership Project (3GPP).

The contents of the present document are subject to continuing work within the TSG and may change following formal TSG approval. Should the TSG modify the contents of the present document, it will be re-released by the TSG with an identifying change of release date and an increase in version number as follows:

Version x.y.z

where:

- x the first digit:
  - 1 presented to TSG for information;
  - 2 presented to TSG for approval;
  - 3 or greater indicates TSG approved document under change control.
- y the second digit is incremented for all changes of substance, i.e. technical enhancements, corrections, updates, etc.
- z the third digit is incremented when editorial only changes have been incorporated in the document.

In the present document, modal verbs have the following meanings:

- shall** indicates a mandatory requirement to do something
- shall not** indicates an interdiction (prohibition) to do something

The constructions "shall" and "shall not" are confined to the context of normative provisions, and do not appear in Technical Reports.

The constructions "must" and "must not" are not used as substitutes for "shall" and "shall not". Their use is avoided insofar as possible, and they are not used in a normative context except in a direct citation from an external, referenced, non-3GPP document, or so as to maintain continuity of style when extending or modifying the provisions of such a referenced document.

- should** indicates a recommendation to do something
- should not** indicates a recommendation not to do something
- may** indicates permission to do something
- need not** indicates permission not to do something

The construction "may not" is ambiguous and is not used in normative elements. The unambiguous constructions "might not" or "shall not" are used instead, depending upon the meaning intended.

- can** indicates that something is possible
- cannot** indicates that something is impossible

The constructions "can" and "cannot" are not substitutes for "may" and "need not".

- will** indicates that something is certain or expected to happen as a result of action taken by an agency the behaviour of which is outside the scope of the present document
- will not** indicates that something is certain or expected not to happen as a result of action taken by an agency the behaviour of which is outside the scope of the present document
- might** indicates a likelihood that something will happen as a result of action taken by some agency the behaviour of which is outside the scope of the present document

**might not** indicates a likelihood that something will not happen as a result of action taken by some agency the behaviour of which is outside the scope of the present document

In addition:

**is** (or any other verb in the indicative mood) indicates a statement of fact

**is not** (or any other negative verb in the indicative mood) indicates a statement of fact

The constructions "is" and "is not" do not indicate requirements.

---

# 1 Scope

The present document establishes 2 sets of minimum requirements and minimum performance requirements; *hybrid requirements set* which specify requirements for a *hybrid AAS BS* with both a conducted and a radiated interface and *OTA requirements set* which specify requirements for an *OTA AAS BS* which has a radiated interface only.

The *hybrid AAS BS* requirements are specified for E-UTRA AAS Base Station (BS), the FDD mode of UTRA AAS Base Station (BS), the 1,28 Mcps TDD mode of UTRA AAS Base Station (BS) in single RAT and any MSR AAS Base Station (BS) implementation of these RATs (including NR BS type 1-H MSR configurations).

The *OTA AAS BS* requirements are specified for E-UTRA AAS Base Station (BS), the FDD mode of UTRA AAS Base Station (BS), in single RAT and any MSR AAS Base Station (BS) implementation of these RATs (including NR BS type 1-O MSR configurations).

NOTE 1: The present document does not establish minimum RF characteristics or minimum performance requirements for Narrow-Band Internet of Things (NB-IoT) in band, NB-IoT guard band, or standalone NB-IoT operation, for AAS BS in *single RAT E-UTRA operation* or in *MSR operation* using E-UTRA.

NOTE 2: The present document does not establish minimum RF characteristics for MBMS for AAS BS in *single RAT E-UTRA operation*.

---

# 2 References

The following documents contain provisions which, through reference in this text, constitute provisions of the present document.

- References are either specific (identified by date of publication, edition number, version number, etc.) or non-specific.
- For a specific reference, subsequent revisions do not apply.
- For a non-specific reference, the latest version applies. In the case of a reference to a 3GPP document (including a GSM document), a non-specific reference implicitly refers to the latest version of that document *in the same Release as the present document*.

- [1] 3GPP TR 21.905: "Vocabulary for 3GPP Specifications".
- [2] 3GPP TS 25.104: "Base Station (BS) radio transmission and reception (FDD)".
- [3] 3GPP TS 25.105: "Base Station (BS) radio transmission and reception (TDD)".
- [4] 3GPP TS 36.104: "Evolved Universal Terrestrial Radio Access (E-UTRA); Base Station (BS) radio transmission and reception".
- [5] 3GPP TS 37.104: "NR, E-UTRA, UTRA and GSM/EDGE Multi-Standard Radio (MSR) Base Station (BS) radio transmission and reception".
- [6] 3GPP TS 25.104 (V16.0.0): "Base Station (BS) radio transmission and reception (FDD) (Release 16)".
- [7] 3GPP TS 25.105 (V16.0.0): "Base Station (BS) radio transmission and reception (TDD) (Release 16)".
- [8] 3GPP TS 36.104 (V16.7.0): "Evolved Universal Terrestrial Radio Access (E-UTRA); Base Station (BS) radio transmission and reception (Release 16)".
- [9] 3GPP TS 37.104 (V16.8.0): "E-UTRA, UTRA and GSM/EDGE Multi-Standard Radio (MSR) Base Station (BS) radio transmission and reception (Release 16)".
- [10] 3GPP TS 25.142 (V16.0.0): "Base Station (BS) conformance testing (TDD) (Release 16)".
- [11] Recommendation ITU-R M.1545: "Measurement uncertainty as it applies to test limits for the terrestrial component of International Mobile Telecommunications-2000".

- [12] 3GPP TS 25.942: "Radio Frequency (RF) system scenarios".
- [13] Void
- [14] Recommendation ITU-R SM.329-10: "Unwanted emissions in the spurious domain".
- [15] "Title 47 of the Code of Federal Regulations (CFR)", Federal Communications Commission.
- [16] 3GPP TS 25.331 (V14.3.0): "Radio Resource Control (RRC); Protocol specification (Release 14)".
- [17] Recommendation ITU-R SM.328-11: "Spectra and bandwidth of emissions".
- [18] FCC publication number 662911: "Emissions Testing of Transmitters with Multiple Outputs in the Same Band".
- [19] 3GPP TS 37.141: "NR, E-UTRA, UTRA and GSM/EDGE; Multi-Standard Radio (MSR) Base Station (BS) conformance testing".
- [20] 3GPP TS 36.141: "Evolved Universal Terrestrial Radio Access (E-UTRA); Base Station (BS) conformance testing".
- [21] IEC 60721-3-3: "Classification of environmental conditions - Part 3-3: Classification of groups of environmental parameters and their severities - Stationary use at weather protected locations".
- [22] IEC 60721-3-4: "Classification of environmental conditions - Part 3: Classification of groups of environmental parameters and their severities - Section 4: Stationary use at non-weather protected locations".
- [23] ETSI EN 300 019-1-3: "Environmental Engineering (EE); Environmental conditions and environmental tests for telecommunications equipment; Part 1-3: Classification of environmental conditions; Stationary use at weather protected locations".
- [24] ETSI EN 300 019-1-4: "Environmental Engineering (EE); Environmental conditions and environmental tests for telecommunications equipment; Part 1-4: Classification of environmental conditions; Stationary use at non-weather protected locations".
- [25] CEPT ECC Decision (13)03, "The harmonised use of the frequency band 1452-1492 MHz for Mobile/Fixed Communications Networks Supplemental Downlink (MFCN SDL)".
- [26] 3GPP TS 45.004: "Digital cellular telecommunications system (Phase 2+); Modulation".
- [27] 3GPP TS 38.104: "NR; Base Station (BS) radio transmission and reception"
- [28] 3GPP TS 38.104 (V15.1.0): "NR; Base Station (BS) radio transmission and reception (Release 15)"
- [29] 3GPP TS 37.145-1: "Active Antenna System (AAS) Base Station (BS) conformance testing; Part 1: Conducted conformance testing"
- [30] 3GPP TS 37.145-2: "Active Antenna System (AAS) Base Station (BS) conformance testing; Part 2: radiated conformance testing"
- [31] 3GPP TS 36.211: "Evolved Universal Terrestrial Radio Access (E-UTRA); Physical channels and modulation"

## 3 Definitions, symbols and abbreviations

### 3.1 Definitions

For the purposes of the present document, the terms and definitions given in 3GPP TR 21.905 [1] and the following apply. A term defined in the present document takes precedence over the definition of the same term, if any, in 3GPP TR 21.905 [1].

NOTE: Multi-word definitions are treated as linguistic expressions and printed in italic font throughout this requirement specification. Linguistic expressions may not be split and are to be printed in their entirety.

**AAS BS receiver:** composite receiver function of an AAS BS receiving in an *uplink operating band*

**active antenna system base station:** base station system which combines an antenna array with a transceiver unit array and a *radio distribution network*

**active transmitter unit:** transmitter unit which is ON, and has the ability to send modulated data streams that are parallel and distinct to those sent from other transmitter units to one or more *TAB connectors* at the *transceiver array boundary*

**band category:** group of *operating bands* for which the same MSR scenarios apply

**Base Station RF Bandwidth:** bandwidth in which a base station transmits and/or receives single or multiple carrier(s) and/or RATs simultaneously within a supported *operating band*

NOTE: In single carrier operation, the *Base Station RF Bandwidth* is equal to the *channel bandwidth*.

**Base Station RF Bandwidth edge:** frequency of one of the edges of the *Base Station RF Bandwidth*

**basic limit:** emissions limit taken from the *non-AAS BS* specifications that is converted into a per *TAB connector TX min cell group* AAS BS emissions limit, or into a per *TAB connector RX min cell group* AAS BS emissions limit by scaling, depending on the context

**beam:** main lobe of a radiation pattern from an AAS BS

NOTE: For certain AAS BS antenna array, there may be more than one beam.

**beam centre direction:** direction equal to the geometric centre of the half-power EIRP contour of the beam

**beam direction pair:** data set consisting of the *beam centre direction* and the related *beam peak direction*

**beam peak direction:** direction where the maximum EIRP is supposed to be found

**beamwidth:** angles describing the major and minor axes of an ellipsoid closest fit to an essentially elliptic half-power EIRP contour of the beam

**carrier:** modulated waveform conveying the E-UTRA or UTRA physical channels

**carrier aggregation:** aggregation of two or more NR or E-UTRA component carriers in order to support wider *transmission bandwidths*

**channel bandwidth:** RF bandwidth supporting a single RF carrier with the *transmission bandwidth* configured in the uplink or downlink of a cell

NOTE 1: The *channel bandwidth* is measured in MHz and is used as a reference for transmitter and receiver RF requirements.

NOTE 2: For UTRA FDD, the *channel bandwidth* is the nominal channel spacing specified in 3GPP TS 25.104 [2], For UTRA TDD 1,28 Mcps, the *channel bandwidth* is the nominal channel spacing specified in 3GPP TS 25.105 [3].

NOTE 3: For E-UTRA, the *channel bandwidths* are specified in 3GPP TS 36.104 [4]. Standalone NB-IoT *channel bandwidths* specified in 3GPP TS 36.104 [4] are not applicable to AAS BS.

NOTE 4: In TS 38.104 [28] for NR, *channel bandwidths* are referred to as BS channel bandwidths, since for NR BS and UE channel bandwidths may differ.

**code domain power:** part of the mean power which correlates with a particular (OVSF) code channel in a UTRA signal

NOTE: The sum of all powers in the code domain equals the mean power in a bandwidth of  $(1+\alpha)$  times the chip rate of the radio access mode.

**co-location reference antenna:** a passive antenna used as reference for base station to base station co-location requirements.

**demodulation branch:** single input of the AAS BS receiver to the demodulation algorithms.

NOTE 1: For UTRA *non-AAS BS* a *demodulation branch* is referred to as a receive diversity branch or an UL MIMO branch. For E-UTRA *non-AAS BS* a *demodulation branch* is referred to as an RX antenna in the performance requirement tables.

NOTE 2: The term "RX antenna" in chapter 8 (i.e. Performance requirements) of the E-UTRA specification 3GPP TS 36.104 [4] does not refer to physical receiver antennas.

**downlink operating band:** part of the (FDD) *operating band* designated for downlink transmission

**enhanced performance requirements type A:** This defines performance requirements assuming baseline receiver as demodulation reference signal based linear minimum mean square error interference rejection combining

**enhanced performance requirements type B:** This defines performance requirements assuming baseline receiver as code word level interference cancellation for intra-cell inter-user interference plus demodulation reference signal based linear minimum mean square error interference rejection combining for inter-cell interference

**equivalent isotropic radiated power:** equivalent power radiated from an isotropic directivity device producing the same field intensity at a point of observation as the field intensity radiated in the direction of the same point of observation by the discussed device

NOTE: Isotropic directivity is equal in all directions (i.e. 0 dBi).

**equivalent isotropic sensitivity:** sensitivity for an isotropic directivity device equivalent to the sensitivity of the discussed device exposed to an incoming wave from a defined AoA

NOTE 1: The sensitivity is the minimum received power level at which a RAT specific requirement is met.

NOTE 2: Isotropic directivity is equal in all directions (i.e. 0 dBi).

**hybrid AAS BS:** AAS BS which has both a conducted RF interface and a radiated RF interface in the far field and conforms to a *hybrid requirements set*

**hybrid requirements set:** complete set of requirements applied to a *hybrid AAS BS* with both conducted and radiated requirements

**inter-band gap:** frequency gap between two supported consecutive operating bands

**Inter RF Bandwidth gap:** frequency gap between two consecutive *Base Station RF Bandwidths* that are placed within two supported *operating bands*

**maximum carrier output power per TAB connector:** mean power level measured on a particular carrier at the *TAB connector(s)*, during the *transmitter ON period* in a specified reference condition

**maximum throughput:** maximum achievable throughput for a reference measurement channel

**minSENS RoAoA:** the *reference RoAoA* associated with the OSDD with the lowest declared EIS value.

**MSR operation:** operation of AAS BS declared to be MSR in particular *operating band(s)* (including any of UTRA, E-UTRA and/or NR operation as SR or multi-RAT based on 37.104)

**multi-band requirements:** requirements applying per one single *operating band* with exclusion bands or other multi-band provisions as defined for each requirement

**multi-band RIB:** operating band specific RIB associated with a transmitter or receiver that is characterized by the ability to process two or more carriers in common active RF components simultaneously, where at least one carrier is configured at a different operating band than the other carrier(s) and where this different operating band is not a sub-band or superseding-band of another supported operating band in which the same RAT is operated.

**multi-band TAB connector:** *TAB connector* associated with a transmitter or receiver that is characterized by the ability to process two or more carriers in common active RF components simultaneously, where at least one carrier is configured at a different operating band than the other carrier(s) and where this different operating band is not a sub-band or superseding-band of another supported operating band in which the same RAT is operated.

**non-AAS BS:** BS conforming to one of the specifications in 3GPP TS 25.104 [2], 3GPP TS 25.105 [3], 3GPP TS 36.104 [4] or 3GPP TS 37.104 [5]

NOTE: For AAS BS in *single RAT E-UTRA operation* or in *MSR operation* using E-UTRA, the NB-IoT operation (including in-band, guard band and standalone operation) is excluded from the consideration in the performance comparison among AAS BS and *non-AAS BS* in this specification.

**non-contiguous spectrum:** spectrum consisting of two or more *sub-blocks* separated by *sub-block gap(s)*

**OTA AAS BS:** AAS BS which has  $\geq 8$  *transceiver units* for E-UTRA or MSR and  $\geq 4$  *transceiver units* for UTRA per cell and has a radiated RF interface only and conforms to the *OTA requirements set*.

**OTA coverage range:** a common range of directions within which TX OTA requirements that are neither specified in the *OTA peak directions sets* nor as TRP requirement are intended to be met

**OTA peak directions set:** set(s) of *beam peak directions* within which certain TX OTA requirements are intended to be met, where all *OTA peak directions set(s)* are subsets of the *OTA coverage range*

NOTE 1: The *beam peak directions* are related to a corresponding contiguous range or discrete list of *beam centre directions* by the *beam direction pairs* included in the set.

NOTE 2: *OTA peak directions set* definition (applicable to multiple *directional requirements*) is replacing the Rel-13/14 *EIRP accuracy directions set* definition (which was applicable to EIRP requirement only).

**OTA REFSENS RoAoA:** Is the RoAoA determined by the contour defined by the points at which the achieved EIS is 3dB higher than the achieved EIS in the reference direction assuming that for any AoA, the receiver gain is optimized for that AoA.

NOTE: This contour will be related to the average element/sub-array radiation pattern 3dB beam width.

**OTA requirements set:** complete set of OTA requirements applied to an *OTA AAS BS*.

**OTA sensitivity directions declaration:** set of manufacturer declarations comprising at least one set of declared minimum EIS values (with related RAT and *channel bandwidth*), and related directions over which the EIS applies

NOTE: All the directions apply to all the EIS values in an OSDD.

**output power at a TAB connector:** mean power delivered to a load with resistance equal to the nominal load impedance of the *TAB connector*

**polarization match:** condition that exists when a plane wave, incident upon an antenna from a given direction, has a polarization that is the same as the receiving polarization of the antenna in that direction

**radiated interface boundary:** operating band specific radiated requirements reference where the radiated requirements apply.

NOTE: For requirements based on EIRP/EIS, the *radiated interface boundary* is associated to the far-field region.

**Radio Bandwidth:** frequency difference between the upper edge of the highest used carrier and the lower edge of the lowest used carrier

**radio distribution network:** linear passive network which distributes the RF power generated by the transceiver unit array to the antenna array, and/or distributes the radio signals collected by the antenna array to the transceiver unit array

NOTE: In the case when the active transceiver units are physically integrated with the array elements of the antenna array, the *radio distribution network* is a one-to-one mapping.

**rated beam EIRP:** EIRP that is declared as being achieved in the *beam peak direction* associated with a particular *beam direction pair*

**rated carrier output power per TAB connector:** mean power level associated with a particular carrier the manufacturer has declared to be available at the *TAB connector*, during the *transmitter ON period* in a specified reference condition

**rated total output power per TAB connector:** mean power level associated with a particular *operating band* the manufacturer has declared to be available at the *TAB connector*, during the *transmitter ON period* in a specified reference condition

**receive period:** time during which the AAS BS is receiving data sub-frames (or UpPTS in case of E-UTRA frame Type2) on a (TDD) carrier

**receiver target:** AoA in which reception is performed by AAS BS

**receiver target redirection range:** union of all the *sensitivity RoAoA* achievable through redirecting the *receiver target* related to particular OSDD

**receiver target reference direction:** direction inside the *OTA sensitivity directions declaration* declared by the manufacturer for conformance testing. For an OSDD without *receiver target redirection range*, this is a direction inside the *sensitivity RoAoA*

**reference beam direction pair:** declared *beam direction pair*, including reference *beam centre direction* and reference *beam peak direction* where the reference *beam peak direction* is the direction for the intended maximum EIRP within the *OTA peak directions set*

**reference RoAoA:** the *sensitivity RoAoA* associated with the *receiver target reference direction* for each OSDD.

**sensitivity RoAoA:** RoAoA within the *OTA sensitivity directions declaration*, within which the declared EIS(s) of an OSDD is intended to be achieved at any instance of time for a specific AAS BS direction setting

**single band requirements:** requirements applying per one single *operating band* without exclusion bands or other multi-band provisions

**single band RIB:** operating band specific RIB supporting operation either in a single *operating band* only, or in multiple *operating bands* but does not meet the conditions for a *multi-band connector*.

**single band TAB connector:** *TAB connector* supporting operation either in a single *operating band* only, or in multiple *operating bands* but does not meet the conditions for a *multi-band RIB*.

**single direction requirement:** AAS BS requirement which is applied in a specific direction within the *OTA coverage range* for the Tx and when the AoA of the incident wave of a received signal is within the OTA REFSENS RoAoA or the minSENS RoAoA as appropriate for the receiver.

**single RAT E-UTRA operation:** operation of AAS BS declared to be single RAT E-UTRA in the *operating band*

NOTE: *Single RAT E-UTRA operation* does not cover in-band NB-IoT, nor guardband NB-IoT operation.

**single RAT UTRA operation:** operation of AAS BS declared to be single RAT UTRA in the *operating band*

**sTTI:** A transmission time interval (TTI) of either one slot or one subslot as defined in TS 36.211 [31] on either uplink or downlink.

**sub-block:** one contiguous allocated block of spectrum for use by the same Base Station

NOTE: There may be multiple instances of *sub-blocks* within a *Base Station RF Bandwidth*.

**sub-block gap:** frequency gap between two consecutive *sub-blocks* within a *Base Station RF Bandwidth*, where the RF requirements in the gap are based on co-existence for un-coordinated operation

**Synchronized operation:** Operation of TDD in two different systems, where no simultaneous uplink and downlink occur.

**TAB connector:** *transceiver array boundary* connector

**TAB connector RX min cell group:** *operating band* specific declared group of *TAB connectors* to which RX requirements are applied.

NOTE: Within this definition, the group corresponds to the group of *TAB connectors* which are responsible for receiving a cell when the AAS BS setting corresponding to the declared minimum number of cells with transmission on all *TAB connectors* supporting an *operating band*, but its existence is not limited to that condition.

**TAB connector TX min cell group:** *operating band* specific declared group of *TAB connectors* to which TX requirements are applied.

NOTE: Within this definition, the group corresponds to the group of *TAB connectors* which are responsible for transmitting a cell when the AAS BS setting corresponding to the declared minimum number of cells with transmission on all *TAB connectors* supporting an *operating band*, but its existence is not limited to that condition.

**throughput:** number of payload bits successfully received per second for a reference measurement channel in a specified reference condition

**total radiated power:** is the total power radiated by the antenna.

NOTE 1: The *total radiated power* is the power radiating in all direction for two orthogonal polarizations.

NOTE 2: *total radiated power* is defined in both the near-field region and the far-field region.

**transceiver array boundary:** conducted interface between the transceiver unit array and the composite antenna

**transmission bandwidth:** RF bandwidth of an instantaneous E-UTRA transmission from a UE or BS, measured in resource Block units

**transmitter OFF period:** time period during which the transmitter is scheduled not to transmit

NOTE: For AAS BS, this definition applies per *TAB connector* and *operating band*.

**transmitter ON period:** time period during which the transmitter is transmitting data and/or reference symbols

NOTE: For AAS BS, this definition applies per *TAB connector* and *operating band*.

**transmitter transient period:** time period during which the transmitter unit belonging to the transceiver unit array is changing from the OFF period to the ON period or vice versa

NOTE: For AAS BS, this definition applies per *TAB connector* and *operating band*.

**Unsynchronized operation:** Operation of TDD in two different systems, where the conditions for synchronized operation are not met.

**uplink operating band:** part of the (FDD) *operating band* designated for uplink transmission

## 3.2 Symbols

For the purposes of the present document, the following symbols apply:

$BeW_{\theta, \text{REFSENS}}$	The beamwidth equivalent to the OTA REFSENS RoAoA in the $\theta$ -axis in degrees.
$BeW_{\phi, \text{REFSENS}}$	The beamwidth equivalent to the OTA REFSENS RoAoA in the $\phi$ -axis in degrees.
$\Delta f_{\text{OBUE}}$	Maximum offset of the <i>operating band</i> unwanted emissions mask from the downlink <i>operating band</i> edge
$\Delta f_{\text{OOB}}$	Maximum offset of the out-of-band boundary from the uplink <i>operating band</i> edge
$\Delta_{\text{minSENS}}$	Difference between conducted reference sensitivity and $EIS_{\text{minsens}}$
$\Delta_{\text{OTAREFSNS}}$	Difference between conducted reference sensitivity and OTA REFSENS
$EIS_{\text{minsens}}$	The EIS declared for the minSENS RoAoA
$F_{\text{DL\_low}}$	The lowest frequency of the downlink <i>operating band</i>
$F_{\text{DL\_high}}$	The highest frequency of the downlink <i>operating band</i>

$N_{\text{cells}}$	The declared number corresponding to the minimum number of cells that can be transmitted by an AAS BS in a particular band with transmission on all <i>TAB connectors</i> supporting the operating band.
$N_{\text{RXU,active}}$	The number of active receiver units. The same as the number of <i>demodulation branches</i> to which compliance is declared for chapter 8 performance requirements.
$N_{\text{RXU,counted}}$	The number of active receiver units that are taken into account for unwanted emission scaling, as calculated in subclause 7.1.
$N_{\text{RXU,countedpercell}}$	The number of active receiver units that are taken into account for unwanted emissions scaling per cell, as calculated in subclause 7.6. The number is defined in subclause 7.1.
$N_{\text{TXU, active}}$	The number of <i>active transmitter units</i> .
$N_{\text{TXU,counted}}$	The number of <i>active transmitter units</i> , as calculated in subclause 6.1, that are taken into account for conducted TX power limit in subclause 6.2, and for unwanted emissions scaling.
$N_{\text{TXU,countedpercell}}$	The number of <i>active transmitter units</i> that are taken into account for emissions scaling per cell, as calculated in subclause 6.6. The number is defined in subclause 6.1.
$P_{\text{max,c,cell}}$	The <i>maximum carrier output power per TAB connector TX min cell group</i>
$P_{\text{max,c,TABC}}$	The <i>maximum carrier output power per TAB connector</i>
$P_{\text{max,c,TRP}}$	The <i>maximum carrier output power per cell</i>
$P_{\text{max,t,TRP}}$	The <i>maximum total output power per cell</i>
$P_{\text{Rated,c,TABC}}$	The <i>rated carrier output power per TAB connector</i>
$P_{\text{rated,c,TRP}}$	The rated carrier TRP
$P_{\text{Rated,c,sys}}$	The sum of $P_{\text{Rated,c,TABC}}$ for all <i>TAB connectors</i> for a single carrier
$P_{\text{Rated,t,group}}$	The sum of $P_{\text{Rated,t,TABC}}$ for all <i>TAB connectors</i> belonging to a specified group
$P_{\text{Rated,t,TABC}}$	The <i>rated total output power per TAB connector</i>
$P_{\text{rated,t,TRP}}$	Rated transmitter TRP declared per RIB
$P_{\text{REFSENS}}$	Conducted reference Sensitivity power level

### 3.3 Abbreviations

For the purposes of the present document, the abbreviations given in 3GPP TR 21.905 [1] and the following apply. An abbreviation defined in the present document takes precedence over the definition of the same abbreviation, if any, in 3GPP TR 21.905 [1].

AAS BS	Active Antenna System Base Station
ACLR	Adjacent Channel Leakage power Ratio
ACS	Adjacent Channel Selectivity
AoA	Angle of Arrival
BC	Band Category
BER	Bit Error Rate
BLER	Block Error Rate
CACLR	Cumulative ACLR
CW	Continuous Wave (unmodulated signal)
D-CPICH	Demodulation Common Pilot Channel
DIP	Dominant Interferer Proportion
EIRP	Equivalent Isotropic Radiated Power
EIS	Equivalent Isotropic Sensitivity
FCC	Federal Communications Commission
FDD	Frequency Division Duplex
FRC	Fixed Reference Channel
HARQ	Hybrid Automatic Repeat Request
HS-DSCH	High Speed Downlink Shared Channel
ITU	International Telecommunication Union
ITU-R	Radio communication Sector of the ITU
MIMO	Multiple Inputs Multiple Outputs
MSR	Multi-Standard Radio
NB-IoT	Narrowband – Internet of Things
OBUE	Operating Band Unwanted Emission
OSDD	OTA Sensitivity Directions Declaration
OTA	Over The Air
OVSF	Orthogonal variable spreading factor
PCCPCH	Primary Common Control Physical CHannel
RAT	Radio Access Technology

RB	Resource Block (for E-UTRA)
RDN	Radio Distribution Network
RE	Resource Element
RF	Radio Frequency
RIB	Radiated Interface Boundary
RoAoA	Range of Angles of Arrival
sPDCCH	shortened Physical Downlink Control Channel
sPDSCH	shortened Physical Downlink Shared Channel
TAB	Transceiver Array Boundary
TDD	Time Division Duplex
TRP	Total Radiated Power
TTI	Transmission Time Interval

---

## 4 General

### 4.1 Relationship between the AAS BS specification and non-AAS BS single RAT & MSR specifications

An AAS BS is distinguished from a *non-AAS BS* by including a dedicated antenna system in its design.

The transceiver to antenna RF interface of the AAS BS (referred to as the *transceiver array boundary*) comprises one or several *TAB connectors*. There is no general one-to-one relationship between *non-AAS BS* antenna connectors and AAS BS *TAB connectors*, but it can be expected the number of *TAB connectors* in AAS BS will be greater than or equal to the number of *non-AAS BS* antenna connectors for respective base stations with corresponding functionality.

For the conducted requirements, the AAS BS requirements are formulated in such a way that the impact of what they are meant to regulate is expected to be "equivalent" to the corresponding *non-AAS BS* requirements; i.e. the outside world sees the same level of emissions, power levels, or can expect the same demodulation performance at the UE from the AAS BS as it would from a *non-AAS BS* with equivalent functionality. All *non-AAS BS* RF requirements (referenced to the *non-AAS BS* antenna connector) have been adapted to AAS BS conducted requirements. Many requirements are also direct references to the *non-AAS BS* RF specifications 3GPP TS 25.104 [2], 3GPP TS 25.105 [3], 3GPP TS 36.104 [4] and 3GPP TS 37.104 [5].

NOTE 1: Applying *non-AAS BS* antenna connector requirements directly to individual *TAB connectors* renders certain AAS BS requirements excessively strict from a system perspective.

NOTE 2: Both specific references and non-specific references occur.

In addition, some new OTA requirements are introduced. These requirements have no corresponding *non-AAS BS* requirements.

For a *OTA AAS BS* there are no conducted requirements. The radiated requirements have been derived based on the principle that they offer the same level of performance and protection as the *hybrid AAS BS* requirements. The radiated requirements therefore use the same equivalence to the non-AAS requirements. The *non-AAS BS* RF requirements have therefore been further adapted to apply to OTA metrics in the far field. Some requirements are direct references to the *non-AAS BS* RF specifications 3GPP TS 25.104 [2], 3GPP TS 25.105 [3], 3GPP TS 36.104 [4] and 3GPP TS 37.104 [5]. Some co-location requirements which have been developed from assumptions on BS-to-BS coupling do not have direct OTA equivalents. The radiated co-location requirements use the same scenarios used to develop the *non-AAS BS* RF requirements.

In this specification, the term "requirements for *single RAT operation*" refers to requirements that are derived from the 3GPP TS 25.104 [2], 3GPP TS 25.105 [3], or 3GPP TS 36.104 [4] specifications baseline, whilst "requirements for *MSR operation*" refers to requirements derived from the 3GPP TS 37.104 [5] specification baseline (including NR operation as part of MSR).

NB-IoT in-band, NB-IoT guard band, or standalone NB-IoT operation is not supported by AAS BS. When referring to standalone E-UTRA requirements for *single RAT operation* in 3GPP TS 36.104 [4] or to E-UTRA requirements for *MSR operation* in 3GPP TS 37.104 [5], any requirements specified in those specifications for E-UTRA with NB-IoT (in-band or guard band) or for standalone NB-IoT, shall not be considered for the AAS BS. Unless otherwise stated, the

exclusion of the NB-IoT requirements in this specification applies to all operation modes (i.e. *in-band NB-IoT operation*, *guard band NB-IoT operation* and *standalone NB-IoT operation*). NR requirements for *single RAT operation* are not specified in the present document because AAS RF requirements for single RAT NR are fully captured in the NR specification 38.104 [27].

Band 46 operation and Band 49 operation is not supported by AAS BS. When referring to standalone E-UTRA requirements for *single RAT operation* in 3GPP TS 36.104 [4] or to E-UTRA requirements for *MSR operation* in 3GPP TS 37.104 [5], any requirements specified in those specifications for Band 46 or Band 49 operation shall not be considered for the AAS BS with E-UTRA.

## 4.2 Relationship between minimum requirements and test requirements

Conformance to the present specification is demonstrated by fulfilling the test requirements specified in the conformance specifications TS 37.145-1 [29] and TS 37.145-2 [30].

The minimum requirements given in this specification make no allowance for measurement uncertainty. The test specifications TS 37.145-1 [29] and TS 37.145-2 [30] define test tolerances. These test tolerances are individually calculated for each test. The test tolerances are used to relax the minimum requirements in this specification to create test requirements. For some requirements, including regulatory requirements, the test tolerance is set to zero.

The measurement results returned by the test system are compared - without any modification - against the test requirements as defined by the shared risk principle. The shared risk principle is defined in Recommendation ITU-R M.1545 [11].

## 4.3 Conducted and radiated requirement reference points

AAS BS requirements are defined for two points of reference, signified by radiated requirements and conducted requirements.

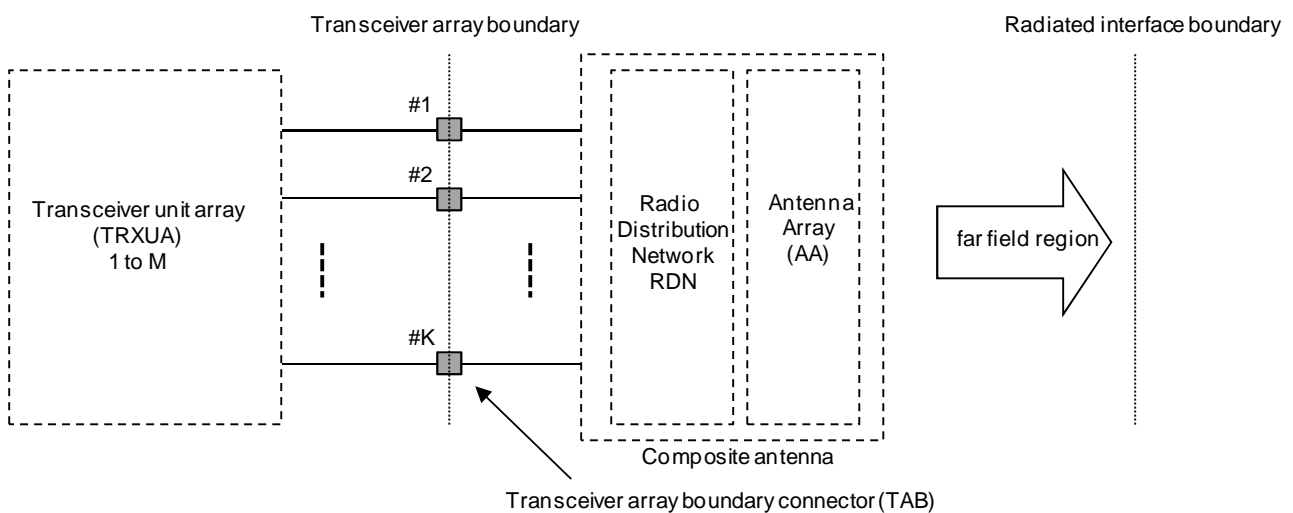
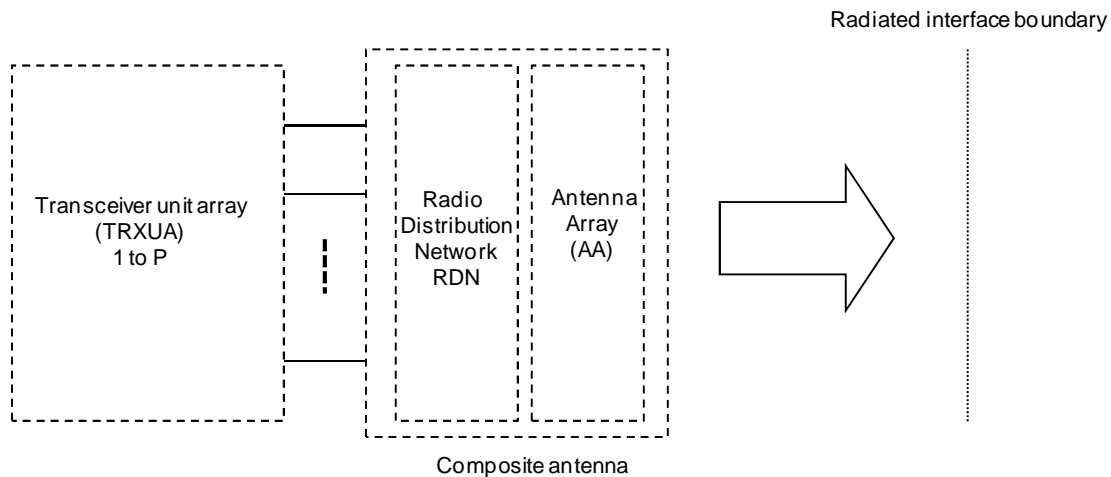

Figure 4.3-1: Radiated and conducted points of reference of hybrid AAS BS



**Figure 4.3-2: Radiated points of reference of OTA AAS BS**

Radiated characteristics are defined over the air (OTA) at the *radiated interface boundary* (RIB). Radiated requirements are also referred to as OTA requirements. The (spatial) directions in which the OTA requirements apply are detailed for each requirement.

Some OTA requirements are specified as co-location requirements where the requirements are specified at the conducted interface of the *co-location reference antenna*, co-location requirements are further defined in subclause 4.10.

Conducted characteristics are defined at individual or groups of *TAB connectors* at the *transceiver array boundary*, which is the conducted interface between the transceiver unit array and the composite antenna.

The transceiver unit array is part of the composite transceiver functionality generating modulated transmit signal structures and performing receiver combining and demodulation.

The transceiver unit array contains an implementation specific number of transmitter units and an implementation specific number of receiver units. Transmitter units and receiver units may be combined into transceiver units. The transmitter/receiver units have the ability to transmit/receive parallel independent modulated symbol streams.

The composite antenna contains a *radio distribution network* (RDN) and an antenna array. The RDN is a linear passive network which distributes the RF power generated by the transceiver unit array to the antenna array, and/or distributes the radio signals collected by the antenna array to the transceiver unit array, in an implementation specific way.

How a conducted requirement is applied to the *transceiver array boundary* is detailed in the respective requirement subclause.

## 4.4 Base station classes for AAS BS

The requirements in the present document apply to AAS BS of Wide Area BS, Medium Range BS and Local Area BS classes unless otherwise stated. The associated deployment scenarios and definitions of BS classes are exactly the same for AAS BS with and without connectors.

BS classes for *OTA AAS BS* are defined as indicated below:

- Wide Area Base Stations are characterised by requirements derived from Macro Cell scenarios with a BS to UE minimum distance along the ground equal to 35 m.
- Medium Range Base Stations are characterised by requirements derived from Micro Cell scenarios with a BS to UE minimum distance along the ground equal to 5 m.
- Local Area Base Stations are characterised by requirements derived from Pico Cell scenarios with a BS to UE minimum distance along the ground equal to 2 m.

BS classes for *hybrid AAS BS* are defined as indicated below:

- Wide Area BS are characterized by requirements derived from Macro Cell scenarios. For *AAS BS* of Wide Area BS class, the minimum coupling loss between any *TAB connector* and the UE is 70 dB.
- Medium Range BS are characterized by requirements derived from Micro Cell scenarios. For *AAS BS* of Medium Range BS class, the minimum coupling loss between any *TAB connector* and the UE is 53 dB.
- Local Area BS are characterized by requirements derived from Pico Cell scenarios. For *AAS BS* of Local Area BS class, the minimum coupling loss between any *TAB connector* and the UE is 45 dB.

NOTE: Whenever WA BS is referred in this specification, the NB-IoT Wide Area BS and related requirements as defined in 3GPP TS 36.104 [4], are not applicable for *OTA AAS BS*, nor for *hybrid AAS BS*.

## 4.5 Regional requirements

Some requirements in the present document may only apply in certain regions either as optional requirements, or as mandatory requirements set by local and regional regulation. It is normally not stated in the 3GPP specifications under what exact circumstances the regional requirements apply, since this is defined by local or regional regulation.

Table 4.5-1 lists all requirements in the present specification that may be applied differently in different regions. *Non-AAS BS* requirements are applicable as defined in the present document. In many cases, such requirements include regional requirements that are implicitly referenced from the present specification, and listed in the specification for the specifications concerned 3GPP TS 25.104 [2], 3GPP TS 25.105 [3], 3GPP TS 36.104 [4] and 3GPP TS 37.104 [5].

Table 4.5-1: List of regional requirements

Clause number	Requirement	Comments
4.6	Operating bands and Band Categories	Some operating bands may be applied regionally.
6.6.2, 9.7.2	Occupied bandwidth and OTA Occupied bandwidth	The requirement may be applied regionally. There may also be regional requirements to declare the Occupied bandwidth according to the definition.
6.6.4, 9.7.4	Spectrum emission mask and OTA Spectrum emission mask	The mask specified may be mandatory in certain regions. In other regions this mask may not be applied. Additional spectrum protection requirements may apply regionally.
6.6.5, 9.7.5	Operating band unwanted emissions and OTA Operating band unwanted emissions	Category A or Category B operating band unwanted emissions limits may be applied regionally.
6.6.5, 9.7.5	Operating band unwanted emissions and OTA Operating band unwanted emissions	The BS may have to comply with the applicable emission limits established by FCC Title 47 [15], when deployed in regions where those limits are applied and under the conditions declared by the manufacturer.
6.6.5, 9.7.5	Operating band unwanted emissions and OTA Operating band unwanted emissions	The requirements for protection of DTT may apply regionally.
6.6.5, 9.7.5	Operating band unwanted emissions and OTA Operating band unwanted emissions	Regional requirement as defined in 3GPP TS 37.104, subclause 6.6.2.4.4 [9] may be applied for the protection of systems operating in frequency bands adjacent to band 1 as defined in 3GPP TS 37.104, subclause 4.5, [9] in geographic areas in which both an adjacent band service and UTRA and/or E-UTRA are deployed.
6.6.5, 9.7.5	Operating band unwanted emissions and OTA Operating band unwanted emissions	Additional requirements defined for Band 24 in 3GPP TS 37.104, subclause 6.6.2.4.5 may apply in regions where FCC regulation applies.
6.6.5, 9.7.5	Operating band unwanted emissions and OTA Operating band unwanted emissions	Additional band 32 unwanted emissions requirements may apply in certain regions
6.6.6, 9.7.6	Spurious emissions and OTA Spurious emissions	Category A limits are mandatory for regions where Category A limits for spurious emissions, as defined in Recommendation ITU-R SM.329 [14] apply. Category B limits are mandatory for regions where Category B limits for spurious emissions, as defined in Recommendation ITU-R SM.329 [14] apply.
6.6.6, 9.7.6	Spurious emissions and OTA Spurious emissions	Additional spurious emissions requirements may be applied for the protection of system operating in frequency ranges other than the AAS BS operating band as described in 3GPP TS 37.104 [9] subclause 6.6.1.3 (NOTE).
6.6.6, 9.7.6	Spurious emissions and OTA Spurious emissions	In addition to 3GPP requirements, the BS may have to comply with the applicable emission limits established by FCC Title 47 [15], when deployed in regions where those limits are applied, and under the conditions declared by the manufacturer.
6.6.6, 9.7.6	Spurious emissions and OTA Spurious emissions	The emission limits specified as the <i>basic limit</i> + X (dB) are applicable, unless stated differently in regional regulation.
6.7, 9.8	Transmitter intermodulation and OTA Transmitter intermodulation	Additional requirements may apply in certain regions.
7.4.2.3, 10.5.2.3	Additional BC3 blocking requirement	This requirement may be applied for the protection of the BS receiver when an MSR BS is operating in the same geographical area as UTRA TDD.
7.5, 10.6	Blocking and OTA Blocking	For the Public Safety LTE BS in Korea from 718 to 728 MHz in Band 28, regional blocking requirement is specified in TS 36.104 [8], subclause 7.6.3.
7.6, 10.7.4	Rx spurious emissions and OTA Rx Spurious emissions	The emission limits specified as the <i>basic limit</i> + X (dB) are applicable, unless stated differently in regional regulation.

## 4.6 Operating Bands and Band Categories

The operating bands and *band categories* for AAS BS are the same as for *non-AAS BS*, as described in 3GPP TS 37.104 [5].

NOTE 1: AAS BS does not support GSM, but BC2 is still applicable for protection of and against GSM operation in BC2 operating bands.

NOTE 2: AAS BS does not support Band 46 (and all its sub-bands defined in 3GPP TS 36.104 [8], subclause 5.5) operation nor Band 49 operation, but Band 46 or Band 49 requirements are still applicable for AAS BS for protection of and against Band 46 or Band 49 operation.

## 4.7 Channel arrangements

The channel arrangements for AAS BS are the same as those for UTRA *non-AAS BS*, E-UTRA *non-AAS BS* and NR *non-AAS BS* as described in 3GPP TS 37.104 [5].

NOTE: Requirements for nominal carrier spacing of 19.8 MHz and 20.1 MHz for carriers in Band 46 as specified in 36.104 [8] subclause 5.7.1, are not applicable for AAS BS.

## 4.8 Requirements for contiguous and non-contiguous spectrum

A spectrum allocation where an AAS BS operates can be either contiguous or non-contiguous. Unless otherwise stated, the requirements in the present specification apply for AAS BS configured for both *contiguous spectrum* operation and *non-contiguous spectrum* operation.

For AAS BS operation in *non-contiguous spectrum*, some requirements apply both at the *Base Station RF Bandwidth edges* and inside the *sub-block gaps*. For each such requirement, it is stated how the limits apply relative to the *Base Station RF Bandwidth edges* and the *sub-block edges* respectively.

## 4.9 Requirements for AAS BS capable of operation in multiple operating bands

For AAS BS capable of operation in multiple operating bands, the RF requirements in clause 6, 7, 9, and 10 apply separately to each supported operating band unless otherwise stated.

A *hybrid AAS BS* may be capable of supporting operation in multiple operating bands with one of the following implementations of *TAB connectors* in the *transceiver array boundary*:

- All *TAB connectors* are *single band TAB connectors*.
- Different sets of *single band TAB connectors* support different operating bands, but each *TAB connector* supports only operation in one single operating band.
- Sets of *single band TAB connectors* support operation in multiple operating bands with some *single band TAB connectors* supporting more than one operating band.
- All *TAB connectors* are *multiband TAB connectors*.
- A combination of single band sets and multi-band sets of *TAB connectors* provides support of the *hybrid AAS BS* capability of operation in multiple operating bands.

Unless otherwise stated all requirements specified for an operating band apply only to the set of *TAB connectors* supporting that operating band.

In certain requirements it is explicitly stated that specific additions or exclusions to the requirement apply at *multi-band TAB connectors* as detailed in the requirement subclause. When referencing the NR specification 3GPP TS 38.104 [27] for a BS type 1-H the multi-band connector term is equivalent to a *multi-band TAB connector* in this specification.

In the case of an operating band being supported only by *single band TAB connectors* in a *TAB connector TX min cell group* or a *TAB connector RX min cell group*, *single band requirements* apply to that set of *TAB connectors*.

NOTE: Each supported operating band needs to be operated separately during conformance testing on *single band TAB connectors*.

For a band supported by a *TAB connector* where the transmitted carriers are not processed in active RF components together with carriers in any other band, *TX single band requirements* shall apply. For a band supported by a *TAB connector* where the received carriers are not processed in active RF components together with carriers in any other band, *RX single band requirements* shall apply.

In the case of an operating band being supported only by *multi-band TAB connectors* supporting the same operating band combination in a *TAB connector TX min cell group* or a *TAB connector RX min cell group*, *multi-band requirements* apply to that set of *TAB connectors*.

The case of an operating band being supported by both *multi-band TAB connectors* and *single band TAB connectors* in a *TAB connector TX min cell group* or a *TAB connector RX min cell group* is not covered by the present release of this specification.

The case of an operating band being supported by *multi-band TAB connectors* which are not all supporting the same operating band combination in a *TAB connector TX min cell group* or a *TAB connector RX min cell group* is not covered by the present release of this specification.

An *OTA AAS BS* may be capable of supporting operation in multiple operating bands with one of the following implementations at the *radiated interface boundary*:

- All RIBs are *single band RIBs*.
- All RIBs are *multiband RIBs*.
- A combination of *single band RIBs* and *multi-band RIBs* provides support of the *OTA AAS BS* capability of operation in multiple operating bands.

In certain requirements it is explicitly stated that specific additions or exclusions to the requirement apply at *multi-band RIBs* as detailed in the requirement subclause.

NOTE: Each supported operating band needs to be operated separately during conformance testing for single RIBs.

For *multi-band TAB connectors* and *multi-band RIBs* supporting the bands for TDD, the RF requirements in the present specification assume no simultaneous uplink and downlink occur between the bands.

The RF requirements for *multi-band TAB connectors* and *multi-band RIBs* supporting bands for both FDD and TDD are not covered by the present release of this specification.

A RIB may operate multi-RAT where the individual RATs are operated in different RAT specific bands that partially or fully overlap;  $\Delta f_{\text{OBUE}}$  and  $\Delta f_{\text{OOb}}$  are according to the combined frequency range occupied by the overlapping bands.

## 4.10 OTA Co-location with other base stations

Co-location requirements are requirements which are based on assuming the AAS BS is co-located with another BS of the same base station class, they ensure that both co-located systems can operate with minimal degradation to each other.

Unwanted emissions and out-of-band blocking co-location requirements are optional requirements based on declaration. TX OFF and TX IMD are mandatory requirements and have the form of a co-location requirement as it represents the worst-case scenario of all the interference cases.

NOTE: Due to the low level of the unwanted emissions for the spurious emissions and TX OFF level, co-location is the most suitable method to show conformance.

The *co-location reference antenna*, shall be a single column passive antenna which has the same vertical radiating dimension (h), frequency range, polarization, as the composite antenna of AAS BS and nominal 65° horizontal half-power beamwidth (suitable for 3-sector deployments) and is placed at a distance *d* from the edge of the AAS BS, as shown in Figure 4.10-1.

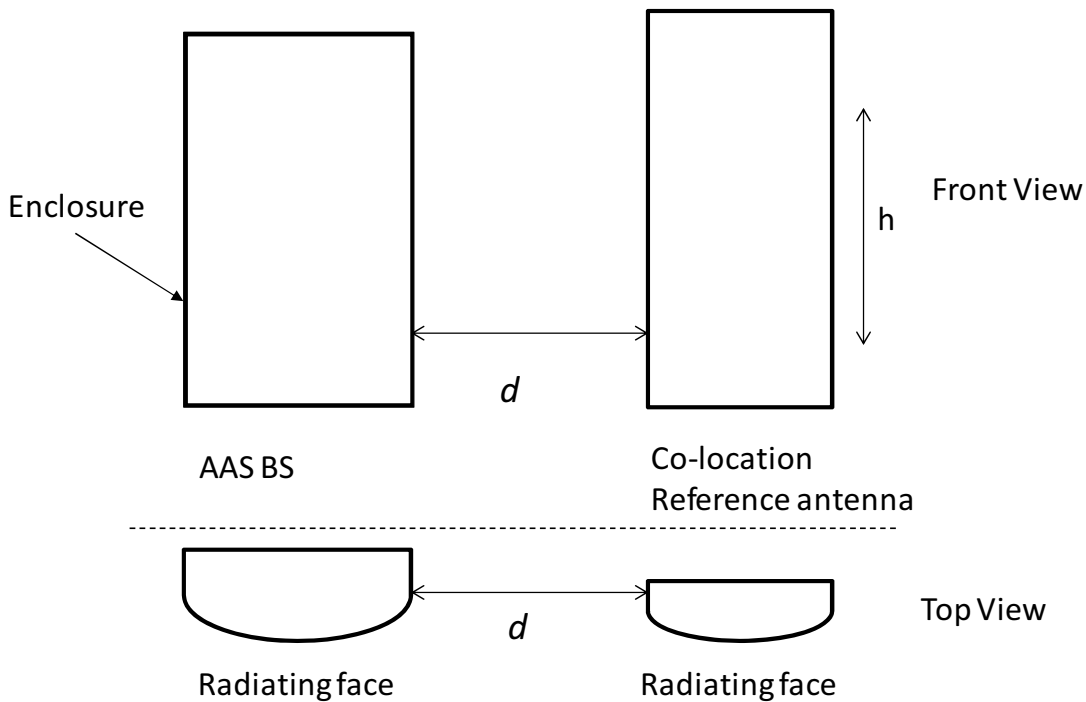

**Figure 4.10-1 Illustration of AAS BS enclosure and *co-location reference antenna***

Edge-to-edge separation  $d$ , between the AAS BS and the *co-location reference antenna* shall be set to 0.1 m.

The AAS BS and the *co-location reference antenna* shall be aligned in a common plane perpendicular to the mechanical bore-sight direction, as shown in figure 4.10-1.

The *co-location reference antenna* and the AAS can have different width.

The vertical radiating regions of the *co-location reference antenna* and the AAS composite antenna shall be aligned.

For co-location requirements where the frequency range of the signal at the *co-location reference antenna* is different from the AAS BS, a *co-location reference antenna* suitable for the frequency stated in the requirement is assumed.

OTA co-location requirements are based on the power at the conducted interface of a *co-location reference antenna*, depending on the requirement this interface is either an input or an output.

For AAS BS with dual polarization the *co-location reference antenna* has two conducted interfaces each representing one polarization.

## 5 Applicability of Requirements

### 5.1 General

The applicability of requirements is related to the band categories described in 3GPP TS 37.104 [5]. This clause captures the requirement clauses' applicability for the respective band categories depending on the operating band specific BS RAT/MSR capability. For each individual band, the manufacturer declares whether the AAS BS conforms to MSR or single RAT requirements.

The applicability of requirements is further related to the declared AAS BS architecture, either a *hybrid AAS BS* or a *OTA AAS BS*. This clause captures the requirement clauses applicability to either the *hybrid AAS BS requirement set* or the *OTA AAS BS requirement set*. The manufacturer declares whether the AAS BS conforms to the *hybrid AAS BS requirement set* or the *OTA AAS BS requirement set*.

In the present specification, requirements for *MSR operation* and for *single RAT operation* are defined. If the AAS BS is declared to be single RAT in an operating band, the respective requirements for *single RAT operation* (derived from 3GPP TS 25.104 [2], 3GPP TS 25.105 [3] or 3GPP TS 36.104 [4]) apply in that operating band. If the AAS BS is

declared to be MSR (operating one or more RATs) in the operating band, the requirements for *MSR operation* (derived from 3GPP TS 35.104 [5]) apply to that operating band. Where requirements for *MSR operation* comprise RAT specific requirements, these apply only when the AAS BS is operating the RAT in the operating band.

NOTE: An AAS BS declared MSR in an operating band and operating only one RAT is differentiated from an AAS BS declared single RAT in the operating band by the fact that requirements are derived from 3GPP TS 37.104 [5] rather than from the single RAT specifications 3GPP TS 25.104 [2], 3GPP TS 25.105 [3] or 3GPP TS 36.104 [4].

## 5.2 Band category 1 (BC1) and band category 2 (BC2)

The RF requirements listed in table 5.2-1 apply to AAS BS for each supported operating band belonging to BC1 and BC2. Requirements apply according to the RAT/MSR capability of the AAS BS in the operating band, as listed in the heading of the table and the declared requirement set (hybrid or OTA). Some requirements listed in the table may not be mandatory or they may apply only regionally. This is further specified in the subclause treating each requirement and in table 4.5-1.

NOTE: Bands in BC1 and BC2 categories are also used for NB-IoT operation. NB-IoT is not applicable for AAS BS.

For operation in multiple operating bands, the applicability of the requirements in table 5.2-1 is determined based on the manufacturer declared AAS BS RAT and single RAT/MSR conformance for each operating band. The applicability of *multi-band requirements* respective *single band requirements* is defined in clause 4.9 and in each referred clause in the table but it cannot be determined by the table itself.

**Table 5.2-1: Applicability of RF requirements for AAS BS operation in BC1 and BC2**

RF requirement	AAS BS is MSR capable in the band		AAS BS is MSR capable and operating UTRA only in the band		AAS BS is MSR capable and operating E-UTRA only in the band		AAS BS is single-RAT UTRA FDD in the band		AAS BS is single-RAT E-UTRA FDD in the band	
	<i>hybrid AAS BS</i>	<i>OTA AAS BS</i>	<i>hybrid AAS BS</i>	<i>OTA AAS BS</i>	<i>hybrid AAS BS</i>	<i>OTA AAS BS</i>	<i>hybrid AAS BS</i>	<i>OTA AAS BS</i>	<i>hybrid AAS BS</i>	<i>OTA AAS BS</i>
Base station output power	6.2.1 6.2.2.1 6.2.2.2 6.2.3.1 6.2.3.2 6.2.5.1 6.2.5.2 6.2.6.1 6.2.6.2	-	6.2.1 6.2.2.1 6.2.2.2 6.2.3.1 6.2.3.2 6.2.5.1 6.2.5.2	-	6.2.1 6.2.2.1 6.2.2.2 6.2.6.1 6.2.6.2	-	6.2.1 6.2.2.1 6.2.2.2 6.2.3.1 6.2.3.3 6.2.5.1 6.2.5.3	-	6.2.1 6.2.2.1 6.2.2.4 6.2.6.1 6.2.6.4	-
Output power dynamics	6.3.1 6.3.2.1 6.3.2.2 6.3.3.1 6.3.3.2 6.3.4.1 6.3.4.2 6.3.5.1 6.3.5.2 6.3.6.1 6.3.6.2	-	6.3.1 6.3.2.1 6.3.2.2 6.3.3.1 6.3.3.2 6.3.4.1 6.3.4.2 6.3.5.1 6.3.5.2	-	6.3.1 6.3.4.1 6.3.4.2 6.3.6.1 6.3.6.2	-	6.3.1 6.3.2.1 6.3.2.3 6.3.3.1 6.3.3.3 6.3.4.1 6.3.4.3 6.3.5.1 6.3.5.3	-	6.3.1 6.3.4.1 6.3.4.4 6.3.6.1 6.3.6.4	-
Transmit ON/OFF power	-	-	-	-	-	-	-	-	-	-
Transmitted signal quality	6.5.1	-	6.5.1	-	6.5.1	-	6.5.1	-	6.5.1	-

Frequency error	6.5.2.1 6.5.2.2	-	6.5.2.1 6.5.2.2	-	6.5.2.1 6.5.2.2	-	6.5.2.1 6.5.2.3	-	6.5.2.1 6.5.2.4	-	
Time alignment error	6.5.3.1 6.5.3.2	-	6.5.3.1 6.5.3.2	-	6.5.3.1 6.5.3.2	-	6.5.3.1 6.5.3.3	-	6.5.3.1 6.5.3.4	-	
Modulation quality	6.5.4.1 6.5.4.2	-	6.5.4.1 6.5.4.2	-	6.5.4.1 6.5.4.2	-	6.5.4.1 6.5.4.3	-	6.5.4.1 6.5.4.4	-	
Transmit pulse shape filter	6.5.5.1 6.5.5.2	-	6.5.5.1 6.5.5.2	-	-	-	6.5.5.1 6.5.5.3	-	-	-	
Unwanted emissions	6.6.1	-	6.6.1	-	6.6.1	-	6.6.1	-	6.6.1	-	
Occupied bandwidth	6.6.2.1 6.6.2.2	-	6.6.2.1 6.6.2.2	-	6.6.2.1 6.6.2.2	-	6.6.2.1 6.6.2.3	-	6.6.2.1 6.6.2.4	-	
ACLR (and Cumulative ACLR)	6.6.3.1 6.6.3.2	-	6.6.3.1 6.6.3.2	-	6.6.3.1 6.6.3.2	-	6.6.3.1 6.6.3.3	-	6.6.3.1 6.6.3.4	-	
Spectrum emission mask	-	-	-	-	-	-	6.6.4.1 6.6.4.3	-	-	-	
Operating band unwanted emissions	6.6.5.1 6.6.5.2	-	6.6.5.1 6.6.5.2	-	6.6.5.1 6.6.5.2	-	-	-	6.6.5.1 6.6.5.4	-	
Transmitter spurious emissions	6.6.6.1 6.6.6.2	-	6.6.6.1 6.6.6.2	-	6.6.6.1 6.6.6.2	-	6.6.6.1 6.6.6.3	-	6.6.6.1 6.6.6.4	-	
Transmitter intermodulation	6.7.1 6.7.2	-	6.7.1 6.7.2	-	6.7.1 6.7.2	-	6.7.1 6.7.3	-	6.7.1 6.7.4	-	
Reference sensitivity level	7.2.1 7.2.2	-	7.2.1 7.2.2	-	7.2.1 7.2.2	-	7.2.1 7.2.3	-	7.2.1 7.2.4	-	
Dynamic range	7.3.1 7.3.2	-	7.3.1 7.3.2	-	7.3.1 7.3.2	-	7.3.1 7.3.3	-	7.3.1 7.3.4	-	
Adjacent channel selectivity and narrowband blocking	7.4.1 7.4.2	-	7.4.1 7.4.2	-	7.4.1 7.4.2	-	7.4.1 7.4.3	-	7.4.1 7.4.4	-	
Blocking	7.5.1 7.5.2	-	7.5.1 7.5.2	-	7.5.1 7.5.2	-	7.5.1 7.5.3	-	7.5.1 7.5.4	-	
Receiver spurious emissions	7.6.1 7.6.2	-	7.6.1 7.6.2	-	7.6.1 7.6.2	-	7.6.1 7.6.3	-	7.6.1 7.6.4	-	
Receiver intermodulation	7.7.1 7.7.2	-	7.7.1 7.7.2	-	7.7.1 7.7.2	-	7.7.1 7.7.3	-	7.7.1 7.7.4	-	
In-channel selectivity	7.8.1 7.8.2	-	-	-	7.8.1 7.8.2	-	-	-	7.8.1 7.8.4	-	
Radiated transmit power	9.2.1 9.2.2		9.2.1 9.2.2		9.2.1 9.2.2		9.2.1 9.2.3		9.2.1 9.2.4		
OTA Base Station output power	-	9.3.1 9.3.2.1 9.3.2.2 9.3.3.1 9.3.3.2 9.3.5.1 9.3.5.2 9.3.6.1 9.3.6.2	-	9.3.1 9.3.2.1 9.3.2.2 9.3.3.1 9.3.3.2 9.3.5.1 9.3.5.2	-	9.3.1 9.3.2.1 9.3.2.2 9.3.6.1 9.3.6.2	-	9.3.1 9.3.2.1 9.3.2.2 9.3.3.1 9.3.3.2 9.3.3.3 9.3.5.1 9.3.5.3	-	9.3.1 9.3.2.1 9.3.2.4 9.3.6.1 9.3.6.4	

OTA Output power dynamics	-	9.4.1 9.4.2.1 9.4.2.2 9.4.3.1 9.4.3.2 9.4.4.1 9.4.4.2 9.4.5.1 9.4.5.2 9.4.6.1 9.4.6.2	-	9.4.1 9.4.2.1 9.4.2.2 9.4.3.1 9.4.3.2 9.4.4.1 9.4.4.2 9.4.5.1 9.4.5.2	-	9.4.1 9.4.4.1 9.4.4.2 9.4.6.1 9.4.6.2	-	9.4.1 9.4.2.1 9.4.2.3 9.4.3.1 9.4.3.3 9.4.4.1 9.4.4.3 9.4.5.1 9.4.5.3	-	9.4.1 9.4.4.1 9.4.4.4 9.4.6.1 9.4.6.4
OTA Transmit ON/OFF power	-	-	-	-	-	-	-	-	-	-
OTA Transmitted signal quality	-	9.6.1	-	9.6.1	-	9.6.1	-	9.6.1	-	9.6.1
OTA Frequency Error	-	9.6.2.1 9.6.2.2	-	9.6.2.1 9.6.2.2	-	9.6.2.1 9.6.2.2	-	9.6.2.1 9.6.2.3	-	9.6.2.1 9.6.2.4
OTA Time alignment error	-	9.6.3.1 9.6.3.2	-	9.6.3.1 9.6.3.2	-	9.6.3.1 9.6.3.2	-	9.6.3.1 9.6.3.3	-	9.6.3.1 9.6.3.4
OTA modulation quality	-	9.6.4.1 9.6.4.2	-	9.6.4.1 9.6.4.2	-	9.6.4.1 9.6.4.2	-	9.6.4.1 9.6.4.3	-	9.6.4.1 9.6.4.4
OTA Transmit pulse shape filter	-	9.6.5.1 9.6.5.2	-	9.6.5.1 9.6.5.2	-	-	-	9.6.5.1 9.6.5.3	-	-
OTA Unwanted Emissions	-	9.7.1	-	9.7.1	-	9.7.1	-	9.7.1	-	9.7.1
OTA Occupied bandwidth	-	9.7.2.1 9.7.2.2	-	9.7.2.1 9.7.2.2	-	9.7.2.1 9.7.2.2	-	9.7.2.1 9.7.2.3	-	9.7.2.1 9.7.2.4
OTA Adjacent Channel Leakage power Ratio	-	9.7.3.1 9.7.3.2	-	9.7.3.1 9.7.3.2	-	9.7.3.1 9.7.3.2	-	9.7.3.1 9.7.3.3	-	9.7.3.1 9.7.3.4
OTA Spectrum emission mask	-	-	-	-	-	-	-	9.7.4.1 9.7.4.3	-	-
OTA Operating band unwanted emission	-	9.7.5.1 9.7.5.2	-	9.7.5.1 9.7.5.2	-	9.7.5.1 9.7.5.2	-	-	-	9.7.5.1 9.7.5.4
OTA Spurious emission	-	9.7.6.1 9.7.6.2	-	9.7.6.1 9.7.6.2	-	9.7.6.1 9.7.6.2	-	9.7.6.1 9.7.6.3	-	9.7.6.1 9.7.6.4
OTA Transmitter intermodulation	-	9.8.1 9.8.2	-	9.8.1 9.8.2	-	9.8.1 9.8.2	-	9.8.1 9.8.3	-	9.8.1 9.8.4
OTA sensitivity		10.2.1 10.2.2		10.2.1 10.2.2		10.2.1 10.2.2		10.2.1 10.2.3		10.2.1 10.2.4
OTA Reference sensitivity level	-	10.3.1 10.3.2	-	10.3.1 10.3.2	-	10.3.1 10.3.2	-	10.3.1 10.3.3	-	10.3.1 10.3.4
OTA Dynamic range	-	10.4.1 10.4.2	-	10.4.1 10.4.2	-	10.4.1 10.4.2	-	10.4.1 10.4.3	-	10.4.1 10.4.4
OTA Adjacent channel selectivity and narrowband blocking	-	10.5.1 10.5.2	-	10.5.1 10.5.2	-	10.5.1 10.5.2	-	10.5.1 10.5.3	-	10.5.1 10.5.4
OTA Blocking	-	10.6.1 10.6.2	-	10.6.1 10.6.2	-	10.6.1 10.6.2	-	10.6.1 10.6.3	-	10.6.1 10.6.4
OTA Receiver spurious emissions	-	10.7.1 10.7.2	-	10.7.1 10.7.2	-	10.7.1 10.7.2	-	10.7.1 10.7.3	-	10.7.1 10.7.4
OTA Receiver intermodulation	-	10.8.1 10.8.2	-	10.8.1 10.8.2	-	10.8.1 10.8.2	-	10.8.1 10.8.3	-	10.8.1 10.8.4
OTA In-channel selectivity	-	10.9.1 10.9.2	-	-	-	10.9.1 10.9.2	-	-	-	10.9.1 10.9.4

NOTE: For some requirements, the requirement is defined by reference to the respective *non-AAS BS*. These requirements cannot be identified from this table.

### 5.3 Band category 3 (BC3)

The RF requirements listed in table 5.3-1 apply to AAS BS for each supported operating band belonging to BC3. Requirements apply according to the RAT/MSR capability of the AAS BS in the operating band, as listed in the heading of the table and the declared requirement set (hybrid or OTA). Some requirements listed in the table may not be mandatory or they may apply only regionally. This is further specified in the clause of each requirement and in table 4.5-1.

For operation in multiple operating bands, the applicability of the requirements in table 5.3-1 is determined based on the manufacturer declared AAS BS RAT and single RAT/MSR conformance for each operating band. The applicability of *multi-band requirements* respective *single band requirements* is defined in clause 4.9 and in each referred clause in the table but it cannot be determined by the table itself.

**Table 5.3-1: Applicability of RF requirements for AAS BS operation in BC3**

RF requirement	AAS BS is MSR capable in the band		AAS BS is MSR capable and operating UTRA only in the band		AAS BS is MSR capable and operating E-UTRA only in the band		AAS BS is single-RAT UTRA TDD in the band		AAS BS is single-RAT E-UTRA TDD in the band	
	<i>hybrid AAS BS</i>	<i>OTA AAS BS</i>	<i>hybrid AAS BS</i>	<i>OTA AAS BS</i>	<i>hybrid AAS BS</i>	<i>OTA AAS BS</i>	<i>hybrid AAS BS</i>	<i>OTA AAS BS</i>	<i>hybrid AAS BS</i>	<i>OTA AAS BS</i>
Base station output power	6.2.1 6.2.2.1 6.2.2.2 6.2.4.1 6.2.4.2 6.2.6.1 6.2.6.2	-	6.2.1 6.2.2.1 6.2.2.2 6.2.4.1 6.2.4.2	-	6.2.1 6.2.2.1 6.2.2.2 6.2.6.1 6.2.6.2	-	6.2.1 6.2.2.1 6.2.2.2 6.2.4.1 6.2.4.3	-	6.2.1 6.2.2.1 6.2.2.2 6.2.6.1 6.2.6.4	-
Output power dynamics	6.3.1 6.3.2.1 6.3.2.2 6.3.3.1 6.3.3.2 6.3.4.1 6.3.4.2 6.3.6.1 6.3.6.2	-	6.3.1 6.3.2.1 6.3.2.2 6.3.3.1 6.3.3.2	-	6.3.1 6.3.4.1 6.3.4.2 6.3.6.1 6.3.6.2	-	6.3.1 6.3.2.1 6.3.2.3 6.3.3.1 6.3.3.3	-	6.3.1 6.3.4.1 6.3.4.4 6.3.6.1 6.3.6.4	-
Transmit ON/OFF power	6.4	-	6.4	-	6.4	-	6.4	-	6.4	-
Transmitted signal quality	6.5.1	-	6.5.1	-	6.5.1	-	6.5.1	-	6.5.1	-
Frequency error	6.5.2.1 6.5.2.2	-	6.5.2.1 6.5.2.2	-	6.5.2.1 6.5.2.2	-	6.5.2.1 6.5.2.3	-	6.5.2.1 6.5.2.4	-
Time alignment error	6.5.3.1 6.5.3.2	-	6.5.3.1 6.5.3.2	-	6.5.3.1 6.5.3.2	-	6.5.3.1 6.5.3.3	-	6.5.3.1 6.5.3.4	-
Modulation quality	6.5.4.1 6.5.4.2	-	6.5.4.1 6.5.4.2	-	6.5.4.1 6.5.4.2	-	6.5.4.1 6.5.4.3	-	6.5.4.1 6.5.4.4	-
Transmit pulse shape filter	6.5.5.1 6.5.5.2	-	6.5.5.1 6.5.5.2	-	-	-	6.5.5.1 6.5.5.3	-	-	-
Unwanted emissions	6.6.1	-	6.6.1	-	6.6.1	-	6.6.1	-	6.6.1	-

Occupied bandwidth	6.6.2.1 6.6.2.2	-	6.6.2.1 6.6.2.2	-	6.6.2.1 6.6.2.2	-	6.6.2.1 6.6.2.3	-	6.6.2.1 6.6.2.4	-
ACLR (and Cumulative ACLR)	6.6.3.1 6.6.3.2	-	6.6.3.1 6.6.3.2	-	6.6.3.1 6.6.3.2	-	6.6.3.1 6.6.3.3	-	6.6.3.1 6.6.3.4	-
Spectrum emission mask	-	-	-	-	-	-	6.6.4.1 6.6.4.3	-	-	-
Operating band unwanted emissions	6.6.5.1 6.6.5.2	-	6.6.5.1 6.6.5.2	-	6.6.5.1 6.6.5.2	-	-	-	6.6.5.1 6.6.5.4	-
Transmitter spurious emissions	6.6.6.1 6.6.6.2	-	6.6.6.1 6.6.6.2	-	6.6.6.1 6.6.6.2	-	6.6.6.1 6.6.6.3	-	6.6.6.1 6.6.6.4	-
Transmitter intermodulation	6.7.1 6.7.2	-	6.7.1 6.7.2	-	6.7.1 6.7.2	-	6.7.1 6.7.3	-	6.7.1 6.7.4	-
Reference sensitivity level	7.2.1 7.2.2	-	7.2.1 7.2.2	-	7.2.1 7.2.2	-	7.2.1 7.2.3	-	7.2.1 7.2.4	-
Dynamic range	7.3.1 7.3.2	-	7.3.1 7.3.2	-	7.3.1 7.3.2	-	7.3.1 7.3.3	-	7.3.1 7.3.4	-
Adjacent channel selectivity and narrowband blocking	7.4.1 7.4.2	-	7.4.1 7.4.2	-	7.4.1 7.4.2	-	7.4.1 7.4.3	-	7.4.1 7.4.4	-
Blocking	7.5.1 7.5.2	-	7.5.1 7.5.2	-	7.5.1 7.5.2	-	7.5.1 7.5.3	-	7.5.1 7.5.4	-
Receiver spurious emissions	7.6.1 7.6.2	-	7.6.1 7.6.2	-	7.6.1 7.6.2	-	7.6.1 7.6.3	-	7.6.1 7.6.4	-
Receiver intermodulation	7.7.1 7.7.2	-	7.7.1 7.7.2	-	7.7.1 7.7.2	-	7.7.1 7.7.3	-	7.7.1 7.7.4	-
In-channel selectivity	7.8.1 7.8.2	-	-	-	7.8.1 7.8.2	-	-	-	7.8.1 7.8.4	-
Radiated transmit power	9.2.1 9.2.2		9.2.1 9.2.2		9.2.1 9.2.2		9.2.1 9.2.3		9.2.1 9.2.4	
OTA Base Station output power	-	9.3.1 9.3.2.1 9.3.2.2 9.3.4.1 9.3.4.2 9.3.6.1 9.3.6.2	-	9.3.1 9.3.2.1 9.3.2.2 9.3.4.1 9.3.4.2	-	9.3.1 9.3.2.1 9.3.2.2 9.3.6.1 9.3.6.2	-	9.3.1 9.3.2.1 9.3.2.3 9.3.4.1 9.3.4.3	-	9.3.1 9.3.2.1 9.3.2.4 9.3.6.1 9.3.6.4
OTA Output power dynamics	-	9.4.1 9.4.2.1 9.4.2.2 9.4.3.1 9.4.3.2 9.4.4.1 9.4.4.2 9.4.6.1 9.4.6.2	-	9.4.1 9.4.2.1 9.4.2.2 9.4.3.1 9.4.3.2	-	9.4.1 9.4.4.1 9.4.4.2 9.4.6.1 9.4.6.2	-	9.4.1 9.4.2.1 9.4.2.3 9.4.3.1 9.4.3.3	-	9.4.1 9.4.4.1 9.4.4.4 9.4.6.1 9.4.6.4
OTA Transmit ON/OFF power	-	9.5	-	9.5	-	9.5	-	9.5	-	9.5
OTA Transmitted signal quality	-	9.6.1	-	9.6.1	-	9.6.1	-	9.6.1	-	9.6.1

OTA Frequency Error	-	9.6.2.1 9.6.2.2	-	9.6.2.1 9.6.2.2	-	9.6.2.1 9.6.2.2	-	9.6.2.1 9.6.2.3	-	9.6.2.1 9.6.2.4
OTA Time alignment error	-	9.6.3.1 9.6.3.2	-	9.6.3.1 9.6.3.2	-	9.6.3.1 9.6.3.2	-	9.6.3.1 9.6.3.3	-	9.6.3.1 9.6.3.4
OTA modulation quality	-	9.6.4.1 9.6.4.2	-	9.6.4.1 9.6.4.2	-	9.6.4.1 9.6.4.2	-	9.6.4.1 9.6.4.3	-	9.6.4.1 9.6.4.4
OTA Transmit pulse shape filter	-	9.6.5.1 9.6.5.2	-	9.6.5.1 9.6.5.2	-	-	-	9.6.5.1 9.6.5.3	-	-
OTA Unwanted Emissions	-	9.7.1	-	9.7.1	-	9.7.1	-	9.7.1	-	9.7.1
OTA Occupied bandwidth	-	9.7.2.1 9.7.2.2	-	9.7.2.1 9.7.2.2	-	9.7.2.1 9.7.2.2	-	9.7.2.1 9.7.2.3	-	9.7.2.1 9.7.2.4
OTA Adjacent Channel Leakage power Ratio	-	9.7.3.1 9.7.3.2	-	9.7.3.1 9.7.3.2	-	9.7.3.1 9.7.3.2	-	9.7.3.1 9.7.3.3	-	9.7.3.1 9.7.3.4
OTA Spectrum emission mask	-	-	-	-	-	-	-	9.7.4.1 9.7.4.3	-	-
OTA Operating band unwanted emission	-	9.7.5.1 9.7.5.2	-	9.7.5.1 9.7.5.2	-	9.7.5.1 9.7.5.2	-	-	-	9.7.5.1 9.7.5.4
OTA Spurious emission	-	9.7.6.1 9.7.6.2	-	9.7.6.1 9.7.6.2	-	9.7.6.1 9.7.6.2	-	9.7.6.1 9.7.6.3	-	9.7.6.1 9.7.6.4
OTA Transmitter intermodulation	-	9.8.1 9.8.2	-	9.8.1 9.8.2	-	9.8.1 9.8.2	-	9.8.1 9.8.3	-	9.8.1 9.8.4
OTA sensitivity		10.2.1 10.2.2		10.2.1 10.2.2		10.2.1 10.2.2		10.2.1 10.2.3		10.2.1 10.2.4
OTA Reference sensitivity level	-	10.3.1 10.3.2	-	10.3.1 10.3.2	-	10.3.1 10.3.2	-	10.3.1 10.3.3	-	10.3.1 10.3.4
OTA Dynamic range	-	10.4.1 10.4.2	-	10.4.1 10.4.2	-	10.4.1 10.4.2	-	10.4.1 10.4.3	-	10.4.1 10.4.4
OTA Adjacent channel selectivity and narrowband blocking	-	10.5.1 10.5.2	-	10.5.1 10.5.2	-	10.5.1 10.5.2	-	10.5.1 10.5.3	-	10.5.1 10.5.4
OTA Blocking	-	10.6.1 10.6.2	-	10.6.1 10.6.2	-	10.6.1 10.6.2	-	10.6.1 10.6.3	-	10.6.1 10.6.4
OTA Receiver spurious emissions	-	10.7.1 10.7.2	-	10.7.1 10.7.2	-	10.7.1 10.7.2	-	10.7.1 10.7.3	-	10.7.1 10.7.4
OTA Receiver intermodulation	-	10.8.1 10.8.2	-	10.8.1 10.8.2	-	10.8.1 10.8.2	-	10.8.1 10.8.3	-	10.8.1 10.8.4
OTA In-channel selectivity	-	10.9.1 10.9.2	-	-	-	10.9.1 10.9.2	-	-	-	10.9.1 10.9.4
NOTE: For some requirements, the requirement is defined by reference to the respective <i>non-AAS BS</i> . These requirements cannot be identified from this table.										

## 6 Conducted transmitter characteristics

### 6.1 General

Unless otherwise stated, the transmitter characteristics are specified with a full complement of transceiver units for the configuration in normal operating conditions.

The manufacturer shall declare the minimum number of supported geographical cells (i.e. geographical areas). The minimum number of supported geographical cells ( $N_{\text{cells}}$ ) relates to the AAS BS setting with the minimum amount of

cell splitting supported with transmission on all *TAB connectors* supporting the operating band. The manufacturer shall also declare *TAB connector TX min cell groups*. Every *TAB connector* supporting transmission in an operating band shall map to one *TAB connector TX min cell group* supporting the same operating band. The mapping of *TAB connectors* to cells is implementation dependent.

The number of *active transmitter units* that are considered when calculating the emissions limit ( $N_{\text{TXU, counted}}$ ) for an AAS BS is calculated as follows:

$$N_{\text{TXU, counted}} = \min(N_{\text{TXU, active}}, 8 \times N_{\text{cells}}) \text{ for AAS BS in single RAT E-UTRA operation and MSR AAS BS (except UTRA only MSR AAS BS)}$$

and

$$N_{\text{TXU, counted}} = \min(N_{\text{TXU, active}}, 4 \times N_{\text{cells}}) \text{ for AAS BS in single RAT UTRA operation and UTRA only MSR AAS BS}$$

Further:

$$N_{\text{TXU, counted per cell}} = N_{\text{TXU, counted}} / N_{\text{cells}}$$

$N_{\text{TXU, counted per cell}}$  is used for scaling the *basic limits* as described in subclause 6.6.

NOTE:  $N_{\text{TXU, active}}$  depends on the actual number of *active transmitter units* and is independent to the declaration of  $N_{\text{cells}}$ .

Any transmitter requirement specified for NB-IoT in-band, NB-IoT guard band, or standalone NB-IoT operation in 3GPP TS 36.104 [4] for E-UTRA with NB-IoT (in-band or guard band) or for standalone NB-IoT, or in 3GPP TS 37.104 [5] for E-UTRA with NB-IoT or standalone NB-IoT in *MSR operation*, and referred in clause 6, is not applicable for AAS BS.

Any transmitter requirement specified for Band 46 operation or for Band 49 operation in 3GPP TS 36.104 [4] for E-UTRA, or in 3GPP TS 37.104 [5] for E-UTRA in *MSR operation*, and referred in clause 6, is not applicable for AAS BS.

## 6.2 Base station output power

### 6.2.1 General

The configured carrier power is the target maximum power for a specific carrier for the operating mode set in the BS within the limits given by the manufacturer's declaration.

### 6.2.2 Maximum output power

#### 6.2.2.1 General

The rated carrier output power of the AAS BS shall be as specified in table 6.2.2.1-1.

**Table 6.2.2.1-1: AAS BS rated output power limits for BS classes**

AAS BS class	$P_{\text{Rated, c, sys}}$	$P_{\text{Rated, c, TABC}}$
Wide Area BS	(NOTE)	(NOTE)
Medium Range BS	$\leq 38 \text{ dBm} + 10\log(N_{\text{TXU, counted}})$	$\leq 38\text{dBm}$
Local Area BS	$\leq 24 \text{ dBm} + 10\log(N_{\text{TXU, counted}})$	$\leq 24\text{dBm}$
NOTE: There is no upper limit for the $P_{\text{Rated, c, sys}}$ or $P_{\text{Rated, c, TABC}}$ of the Wide Area Base Station.		

## 6.2.2.2 Minimum requirement for MSR operation

### 6.2.2.2.1 General

In normal conditions,  $P_{\max,c,TABC}$  shall remain within +2 dB and -2 dB of the configured carrier power for each *TAB connector* as declared by the manufacturer.

In extreme conditions,  $P_{\max,c,TABC}$  shall remain within +2,5 dB and -2,5 dB of the configured carrier power for each *TAB connector* as declared by the manufacturer.

In certain regions, the minimum requirement for normal conditions may apply also for some conditions outside the range of conditions defined as normal.

### 6.2.2.2.2 Additional requirements (regional)

## 6.2.2.3 Minimum requirement for single RAT UTRA operation

The minimum requirement for single RAT UTRA BS is the same as that defined in subclause 6.2.2.2.

## 6.2.2.4 Minimum requirement for single RAT E-UTRA operation

### 6.2.2.4.1 General

The minimum requirement for single RAT E-UTRA BS is the same as that defined in subclause 6.2.2.2.

### 6.2.2.4.2 Additional requirements (regional)

## 6.2.3 UTRA FDD primary CPICH power

### 6.2.3.1 General

This requirement applies to the *TAB connector* group(s) transmitting primary CPICH.

Primary CPICH (P-CPICH) power is the *code domain power* of the Primary Common Pilot Channel summed over the *TAB connectors* transmitting the P-CPICH for a cell. P-CPICH power is indicated on the BCH.

NOTE 1: A *TAB connector* group may comprise all *TAB connectors*.

NOTE 2: A *TAB connector* may be mapped to several groups.

NOTE 3: The manufacturer declares the *TAB connector* mapping to the P-CPICH transmission group(s) as specified in TS 37.145-1 [29] or TS 37.145-2 [30].

### 6.2.3.2 Minimum requirement for MSR operation

The minimum requirement for MSR UTRA FDD operation is the same as that defined in subclause 6.2.3.3. There is no CPICH power requirement for UTRA TDD 1,28 Mcps operation.

There is no CPICH power requirement for E-UTRA operation.

There is no CPICH power requirement for NR operation.

### 6.2.3.3 Minimum requirement for single RAT UTRA operation

The difference between the P-CPICH power and the P-CPICH power indicated on the BCH shall be within  $\pm 2,1$  dB.

Alternatively, the P-CPICH power measured at each *TAB connector* shall be within  $\pm 2,1$  dB of the P-CPICH power level indicated on the BCH multiplied by a *TAB connector* specific beamforming weight. Beamforming weights on P-CPICH are set by the AAS BS to achieve an intended radiated pattern.

There is no P-CPICH power requirement for UTRA TDD 1,28 Mcps operation.

#### 6.2.3.4 Minimum requirement for single RAT E-UTRA operation

There is no CPICH power requirement for E-UTRA AAS BS.

### 6.2.4 UTRA TDD primary CCPCH power

#### 6.2.4.1 General

This requirement applies to the *TAB connector* group(s) transmitting primary CCPCH. It comprises primary CCPCH (PCCPCH) absolute power accuracy, and differential accuracy.

Primary CCPCH power is the *code domain power* of the primary common control physical channel averaged over the transmit timeslot and summed over the *TAB connectors* transmitting the PCCPCH for a cell. Primary CCPCH power is signalled over the BCH.

The differential accuracy of the Primary CCPCH power is the relative transmitted power accuracy of PCCPCH in consecutive frames when the nominal PCCPCH power is not changed.

NOTE 1: A *TAB connector* group may comprise all *TAB connectors*.

NOTE 2: A *TAB connector* may be mapped to several groups.

NOTE 3: The manufacturer declares the *TAB connector* mapping to the PCCPCH transmission group(s).

#### 6.2.4.2 Minimum requirement for MSR operation

The minimum requirement for MSR UTRA TDD 1,28 Mcps operation is the same as that defined in subclause 6.2.4.3.

There is no CCPCH power requirement for UTRA FDD operation.

There is no CCPCH power requirement for E-UTRA operation.

There is no CCPCH power requirement for NR operation.

#### 6.2.4.3 Minimum requirement for single RAT UTRA operation

For UTRA TDD 1,28 Mcps operation, the difference between the BCH-broadcast value of the Primary CCPCH power and the Primary CCPCH power averaged over the timeslot shall not exceed the values in table 6.2.4.3-1. The requirement is a function of the output power from the *TAB connector* group transmitting PCCPCH averaged over the transmit timeslot,  $P_{out}$ , and the manufacturer's rated total power of the group,  $P_{rated,t,group}$ .

**Table 6.2.4.3-1: Difference between Primary CCPCH power and the broadcast value**

Output power in slot (dB)	PCCPCH power tolerance
$P_{rated,t,group} - 3 < P_{out} \leq P_{rated,t,group} + 2$	$\pm 2,5$ dB
$P_{rated,t,group} - 6 < P_{out} \leq P_{rated,t,group} - 3$	$\pm 3,5$ dB
$P_{rated,t,group} - 13 < P_{out} \leq P_{rated,t,group} - 6$	$\pm 5$ dB
NOTE: $P_{rated,t,group}$ is the power sum of $P_{rated,t,TABC}$ of all the <i>TAB connectors</i> in the group transmitting PCCPCH.	

The differential accuracy of PCCPCH power shall be within  $\pm 0,5$  dB.

Alternatively, the PCCPCH power measured at each *TAB connector* and averaged over the timeslot shall be within the tolerance indicated in table 6.2.4.3-1 of the PCCPCH power level indicated on the BCH that is multiplied by a *TAB connector* specific beamforming weight. Beamforming weights on PCCPCH are set by the AAS BS to achieve an intended radiated pattern.

In this case, the differential accuracy of PCCPCH power shall be within  $\pm 0,5$  dB on each *TAB connector* in the *TAB connector* group.

There is no PCCPCH power requirement for UTRA FDD operation.

#### 6.2.4.4 Minimum requirement for single RAT E-UTRA operation

There is no CCPCH power requirement for E-UTRA operation.

### 6.2.5 UTRA FDD additional CPICH power for MIMO mode

#### 6.2.5.1 General

This clause includes requirements on secondary CPICH power level, for two and four *TAB connector* groups, as well as Demodulation CPICH requirements. The requirements apply to all *TAB connector* groups associated with UTRA FDD MIMO transmission as "antenna 2", "antenna 3" or "antenna 4" in the AAS BS.

The concept of "antenna 2", "antenna 3" and "antenna 4" is described in 3GPP TS 25.104 [2]. The group(s) of *TAB connectors* mapped to P-CPICH transmission represents "antenna 1".

NOTE 1: The manufacturer declares the mapping of *TAB connectors* to "antenna 1", "antenna 2", "antenna 3" and "antenna 4" (as defined in 3GPP TS 25.331 [16]) where applicable for AAS BS capable of UTRA FDD operation. The required declarations are specified in TS 37.145-1 [29] and TS 37.145-2 [30].

For UTRA FDD AAS BS operating only "antenna 1" and "antenna 2", the secondary CPICH (S-CPICH) power is the *code domain power* of the Secondary Common Pilot Channel. S-CPICH power is equal to the (dB) sum of the P-CPICH power and the power offset, which are signalled to the UE. The power offset is signalled in the IE "Power Offset for S-CPICH for MIMO", for MIMO mode as defined in clause 10.3.6.41b in 3GPP TS 25.331 [16].

When the UE supports MIMO mode with four BS transmit antennas, the power offset of S-CPICH on antenna 2 is signalled in the IE "Power Offset for S-CPICH for MIMO mode with four transmit antennas on Antenna2" as defined in subclause 10.3.6.143 in 3GPP TS 25.331 [16]. The power offset of S-CPICH on antenna 3 and 4 is signalled in the IE "Common Power Offset for S-CPICH for MIMO mode with four transmit antennas on Antenna3 and 4", as defined in subclause 10.3.6.143 in 3GPP TS 25.331 [16].

Demodulation CPICH (D-CPICH) power is the *code domain power* of the Demodulation Common Pilot Channel. D-CPICH power is equal to the (dB) sum of the P-CPICH power and the power offset, which are signalled to the UE. The power offset of D-CPICH on antenna 3 and 4 is signalled in the IE "Common Power Offset for D-CPICH for MIMO mode with four transmit antennas on Antenna3 and 4", as defined in subclause 10.3.6.143 in 3GPP TS 25.331 [16].

NOTE 2: The accuracy level of the power offset for S-CPICH may affect both MIMO HS-DSCH demodulation and CQI reporting performance.

NOTE 3: The accuracy level of the power offset for D-CPICH transmitted on antennas 3 and 4 may affect both MIMO HS-DSCH demodulation and CQI reporting performance.

NOTE 4: At high geometry level PDSCH performance may be affected if D-CPICH is not scheduled.

NOTE 5: A *TAB connector* group may comprise all *TAB connectors*.

NOTE 6: A *TAB connector* may be mapped to several groups.

#### 6.2.5.2 Minimum requirement for MSR operation

The minimum requirements for MSR UTRA FDD operation are the same as those defined in subclause 6.2.5.3.

There is no CPICH power requirement for UTRA TDD 1,28 Mcps operation.

There is no CPICH power requirement for E-UTRA operation.

There is no CPICH power requirement for NR operation.

#### 6.2.5.3 Minimum requirement for single RAT UTRA operation

When operating MIMO only "antenna 1" and "antenna 2";

The difference between the P-CPICH power transmitted at the group of *TAB connectors* mapped to "antenna 1", and the S-CPICH power transmitted at the corresponding group of *TAB connectors* mapped to "antenna 2" shall be within  $\pm 2$  dB of the IE "Power Offset for S-CPICH for MIMO".

Alternatively, the measured power of the P-CPICH mapped to "antenna 1" and the measured power of the S-CPICH mapped to "antenna 2" at each *TAB connector* shall be within 2 dB of the corresponding IE "Power Offset for S-CPICH for MIMO" that is multiplied by a *TAB connector* specific beamforming weight and the P-CPICH power level indicated on the BCH. The same beamforming weights applied to P-CPICH and S-CPICH are set by the AAS BS to achieve an intended radiated pattern.

When operating MIMO "antenna 1", "antenna 2", "antenna 3", and "antenna 4".

The difference between the P-CPICH power transmitted at the group of *TAB connectors* mapped to "antenna 1", and the S-CPICH power transmitted at the corresponding group of *TAB connectors* mapped to "antenna 2" shall be within  $\pm 2$  dB of the IE "Power Offset for S-CPICH for MIMO mode with four transmit antennas on Antenna2".

The difference between the P-CPICH power transmitted at the group of *TAB connectors* mapped to "antenna 1" and the S-CPICH power transmitted at the corresponding groups of *TAB connectors* mapped to "antenna 3" and "antenna 4" respectively, shall be within  $\pm 2$  dB of the IE "Common Power Offset for S-CPICH for MIMO mode with four transmit antennas on Antenna3 and 4".

Alternatively, the measured power of the P-CPICH mapped to "antenna 1" and the measured power of the S-CPICH mapped to "antenna 2" at each *TAB connector* shall be within  $\pm 2$  dB of the corresponding IE "Power Offset for S-CPICH for MIMO mode with four transmit antennas on Antenna2" that is multiplied by a *TAB connector* specific beamforming weight and the P-CPICH power level indicated on the BCH. The measured power of the P-CPICH mapped to "antenna 1" and the measured power of the S-CPICH mapped to "antenna 3" and "antenna 4", respectively, at each *TAB connector* shall be within  $\pm 2$  dB of the corresponding IE "Power Offset for S-CPICH for MIMO mode with four transmit antennas on Antenna3 and 4" that is multiplied by a *TAB connector* specific beamforming weight and the P-CPICH power level indicated on the BCH. The same beamforming weights applied to P-CPICH and S-CPICH are set by the AAS BS to achieve an intended radiated pattern.

If D-CPICH is scheduled:

The difference between the P-CPICH power transmitted at the group of *TAB connectors* mapped to "antenna 1" and the D-CPICH power transmitted at the corresponding groups of *TAB connectors* mapped to "antenna 3" and "antenna 4" respectively, shall be within  $\pm 2$  dB of the IE "Common Power Offset for D-CPICH for MIMO mode with four transmit antennas on Antenna3 and 4".

Alternatively, the measured power of the P-CPICH mapped to "antenna 1" and the measured power of the D-CPICH mapped to "antenna 3" and "antenna 4", respectively, at each *TAB connector* shall be within  $\pm 2$  dB of the corresponding IE "Common Power Offset for D-CPICH for MIMO mode with four transmit antennas on Antenna3 and 4" that is multiplied by a *TAB connector* specific beamforming weight and the P-CPICH power level indicated on the BCH. The same beamforming weights applied to P-CPICH and D-CPICH are set by the AAS BS to achieve an intended radiated pattern.

There is no CPICH power requirement for UTRA TDD 1,28 Mcps operation.

#### 6.2.5.4 Minimum requirement for single RAT E-UTRA operation

There is no CPICH power requirement for E-UTRA AAS BS.

### 6.2.6 E-UTRA DL RS power

#### 6.2.6.1 General

This requirement applies to the *TAB connector* group(s) transmitting primary DL RS.

The DL RS power is the resource element power of the Downlink Reference Symbol summed over the group of *TAB connectors* transmitting the DL RS for a cell.

The absolute DL RS power is indicated on the DL-SCH. The absolute accuracy is defined as the maximum deviation between the DL RS power indicated on the DL-SCH and the DL RS power of each E-UTRA carrier.

NOTE 1: A *TAB connector* group may comprise all *TAB connectors*.

NOTE 2: A *TAB connector* may be mapped to several groups.

NOTE 3: The manufacturer declares the *TAB connector* mapping to the DL RS transmission group(s).

### 6.2.6.2 Minimum requirement for MSR operation

There is no DL RS power requirement for UTRA operation.

There is no DL RS power requirement for NR operation.

The minimum requirement for MSR E-UTRA operation is the same as that defined in subclause 6.2.6.4.

### 6.2.6.3 Minimum requirement for single RAT UTRA operation

There is no DL RS power requirement for UTRA operation.

### 6.2.6.4 Minimum requirement for single RAT E-UTRA operation

The DL RS power of each E-UTRA carrier shall be within  $\pm 2,1$  dB of the DL RS power indicated on the DL-SCH.

Alternatively, the DL RS power measured at each *TAB connector* shall be within  $\pm 2,1$  dB of the DL RS power level indicated on the DL-SCH multiplied by a *TAB connector* specific beamforming weight. Beamforming weights on P-CPICH are set by the AAS BS to achieve an intended radiated pattern.

## 6.3 Output power dynamics

### 6.3.1 General

The requirements in subclause 6.3 apply during the *transmitter ON period*. Transmit signal quality (as specified in subclause 6.5) shall be maintained for the output power dynamics requirements.

### 6.3.2 UTRA Inner loop power control in the downlink

#### 6.3.2.1 General

Inner loop power control in the downlink is the ability of the AAS BS to adjust the transmitted output power of a code channel in accordance with the corresponding TPC commands received in the uplink.

This requirement applies at each *TAB connector* supporting transmission in the operating band.

#### 6.3.2.2 Minimum requirement for MSR operation

For UTRA FDD operation the minimum requirements for MSR AAS BS inner loop power control in the DL are the same as in subclause 6.3.2.3.

For UTRA TDD 1,28 Mcps operation the minimum requirements for MSR AAS BS inner loop power control in the DL are the same as in 3GPP TS 25.105 [7], subclause 6.4.2.1.

This requirement does not apply to E-UTRA or NR operation.

#### 6.3.2.3 Minimum requirement for single RAT UTRA operation

For UTRA FDD operation, the Single RAT AAS BS shall have the capability of setting the inner loop *code domain power* on each *TAB connector* with a step sizes of 1dB mandatory and 0,5, 1,5, 2,0 dB optional.

- a) The tolerance of the power control step due to inner loop power control shall be within the range shown in table 6.3.2.3-1.

- b) The tolerance of the combined output power change due to inner loop power control shall be within the range shown in table 6.3.2.3-2.

**Table 6.3.2.3-1: UTRA FDD TAB connector power control step tolerance**

Power control commands in the down link	Transmitter power control step tolerance							
	2 dB step size (NOTE)		1,5 dB step size (NOTE)		1 dB step size		0,5 dB step size (NOTE)	
	Lower	Upper	Lower	Upper	Lower	Upper	Lower	Upper
Up (TPC command "1")	+1,0 dB	+3,0 dB	+0,75 dB	+2,25 dB	+0,5 dB	+1,5 dB	+0,25 dB	+0,75 dB
Down (TPC command "0")	-1,0 dB	-3,0 dB	-0,75 dB	-2,25 dB	-0,5 dB	-1,5 dB	-0,25 dB	-0,75 dB
NOTE: These requirements are optional for AAS BS in <i>single RAT UTRA operation</i> , or in <i>MSR operation</i> using UTRA FDD.								

**Table 6.3.2.3-2: UTRA FDD TAB connector aggregated power control step range**

Power control commands in the down link	Transmitter aggregated power control step change after 10 consecutive equal commands (up or down)							
	2 dB step size (NOTE)		1,5 dB step size (NOTE)		1 dB step size		0,5 dB step size (NOTE)	
	Lower	Upper	Lower	Upper	Lower	Upper	Lower	Upper
Up (TPC command "1")	+16 dB	+24 dB	+12 dB	+18 dB	+8 dB	+12 dB	+4 dB	+6 dB
Down (TPC command "0")	-16 dB	-24 dB	-12 dB	-18 dB	-8 dB	-12 dB	-4 dB	-6 dB
NOTE: These requirements are optional for AAS BS in <i>single RAT UTRA operation</i> , or in <i>MSR operation</i> using UTRA FDD.								

For UTRA TDD 1,28 Mcps operation; the minimum requirements for AAS BS in *single RAT UTRA operation* using TDD inner loop power control in the DL are the same as in 3GPP TS 25.105 [7], subclause 6.4.2.1.

#### 6.3.2.4 Minimum requirement for single RAT E-UTRA operation

This requirement does not apply to E-UTRA operation.

### 6.3.3 Power control dynamic range

#### 6.3.3.1 General

The power control dynamic range is the difference between the maximum and the minimum *code domain power* of a code channel for a specified reference condition.

This requirement applies at each *TAB connector* supporting transmission in the operating band.

#### 6.3.3.2 Minimum requirement for MSR operation

For UTRA FDD operation the minimum requirements for MSR AAS BS power control dynamic range are the same as in 3GPP TS 25.104 [6], subclause 6.4.2.1.

For UTRA TDD 1,28 Mcps operation the minimum requirement for MSR AAS BS power control dynamic range is the same as in 3GPP TS 25.105 [7], subclause 6.4.3.1.

This requirement does not apply to E-UTRA or NR operation.

#### 6.3.3.3 Minimum requirement for single RAT UTRA operation

For UTRA FDD operation the minimum requirements for single RAT AAS BS power control dynamic range are the same as in 3GPP TS 25.104 [6], subclause 6.4.2.1.

For UTRA TDD 1,28 Mcps operation the minimum requirement for single RAT AAS BS power control dynamic range is the same as in 3GPP TS 25.105 [7], subclause 6.4.3.1.

#### 6.3.3.4 Minimum requirement for single RAT E-UTRA operation

This requirement does not apply to E-UTRA operation.

### 6.3.4 Total power dynamic range

#### 6.3.4.1 General

The total power dynamic range is the difference between the maximum and the minimum output power for a specified reference condition.

This requirement applies at each *TAB connector* supporting transmission in the operating band.

NOTE 1: The upper limit of the dynamic range is the BS maximum output power ( $P_{\text{Rated,c,TABC}}$ ). The lower limit of the dynamic range is the lowest minimum power from the BS when no traffic channels are activated.

Particularly for E-UTRA and NR, the total power dynamic range is the difference between the maximum and the minimum transmit power of an OFDM symbol for a specified reference condition.

NOTE 2: The upper limit of the dynamic range at a *TAB connector* is the OFDM symbol power when transmitting on all RBs at maximum output power ( $P_{\text{Rated,c,TABC}}$ ). The lower limit of the dynamic range at a *TAB connector* is the OFDM symbol power when one resource block is transmitted. The OFDM symbol carries PDSCH or sPDSCH and not contain RS, PBCH or synchronization signals.

#### 6.3.4.2 Minimum requirement for MSR operation

For UTRA FDD operation; the minimum requirements for MSR AAS BS total power dynamic range are the same as in 3GPP TS 25.104 [6], subclause 6.4.3.1.

This requirement does not apply to UTRA TDD operation.

For E-UTRA operation, the minimum requirements for MSR AAS BS total power dynamic range are the same as in 3GPP TS 36.104 [8], subclause 6.3.2.1.

For NR operation, the minimum requirements for MSR AAS BS total power dynamic range are the same as those for *BS type I-H* in 3GPP TS 38.104 [28], subclause 6.3.3.2.

#### 6.3.4.3 Minimum requirement for single RAT UTRA operation

For UTRA FDD operation; the minimum requirements for single RAT AAS BS total power dynamic range are the same as in 3GPP TS 25.104 [6], subclause 6.4.3.1.

This requirement does not apply to UTRA TDD operation.

#### 6.3.4.4 Minimum requirement for single RAT E-UTRA operation

For E-UTRA operation; the minimum requirements for single RAT AAS BS total power dynamic range are the same as in 3GPP TS 36.104 [8], subclause 6.3.2.1.

### 6.3.5 IPDL time mask

#### 6.3.5.1 General

To support IPDL location method in UTRA FDD operation, the AAS BS shall interrupt all transmitted signals in the downlink (i.e. common and dedicated channels). The IPDL time mask specifies the limits of the *TAB connector* output power during these idle periods.

This requirement applies only to AAS BS supporting IPDL. The requirement applies at each *TAB connector* supporting transmission in the operating band.

### 6.3.5.2 Minimum requirement for MSR operation

For UTRA FDD operation; the minimum requirement for MSR AAS BS IPDL time mask is the same as in 3GPP TS 25.104 [6], subclause 6.4.5.1.

This requirement does not apply to UTRA TDD operation.

This requirement does not apply to E-UTRA operation.

This requirement does not apply to NR operation.

### 6.3.5.3 Minimum requirement for single RAT UTRA operation

For UTRA FDD operation; the minimum requirement for single RAT AAS BS IPDL time mask is the same as in 3GPP TS 25.104 [6], subclause 6.4.5.1.

This requirement does not apply to UTRA TDD operation.

### 6.3.5.4 Minimum requirement for single RAT E-UTRA operation

This requirement does not apply to E-UTRA operation.

## 6.3.6 RE Power control dynamic range

### 6.3.6.1 General

The RE power control dynamic range is the difference between the power of an RE and the average RE power for a BS at maximum output power ( $P_{\text{Rated,c,TABC}}$ ) for a specified reference condition.

This requirement applies at each *TAB connector* supporting transmission in the operating band.

### 6.3.6.2 Minimum requirement for MSR operation

This requirement does not apply to UTRA operation.

For E-UTRA operation; the minimum requirements for MSR AAS BS RE power control dynamic range are the same as in 3GPP TS 36.104 [8], subclause 6.3.1.1.

For NR operation, the minimum requirements for MSR AAS BS RE power control dynamic range are the same as those for *BS type 1-H* in 3GPP TS 38.104 [28], subclause 6.3.2.2.

### 6.3.6.3 Minimum requirement for single RAT UTRA operation

This requirement does not apply to UTRA operation.

### 6.3.6.4 Minimum requirement for single RAT E-UTRA operation

For E-UTRA operation; the minimum requirements for single RAT AAS BS RE power control dynamic range are the same as in 3GPP TS 36.104 [8], subclause 6.3.1.1.

## 6.4 Transmit ON/OFF power

### 6.4.1 General

Transmitter ON/OFF power requirements apply only to TDD operation of UTRA and E-UTRA.

## 6.4.2 Transmitter OFF power

### 6.4.2.1 General

Transmitter OFF power is defined as the mean power measured over  $70/N$   $\mu$ s filtered with a square filter of bandwidth equal to the *Base Station RF Bandwidth* (s) centred on the central frequency of the *Base Station RF Bandwidth* (s) during the *transmitter OFF period*.  $N$  is equal to 1 for UTRA and E\_UTRA SCS/15 for NR, where SCS is Sub Carrier Spacing in kHz.

The requirement applies at each *TAB connector* supporting transmission in the operating band.

For *multi-band TAB connectors* and for *single band TAB connectors* supporting transmission in multiple operating bands, the requirement is only applicable during the *transmitter OFF period* in all supported operating bands.

For AAS BS supporting intra-band contiguous CA, the transmitter OFF power is defined as the mean power measured over  $70/N$   $\mu$ s filtered with a square filter of bandwidth equal to the *Aggregated BS Channel Bandwidth*  $BW_{\text{Channel\_CA}}$  centred on  $(F_{\text{edge,high}} + F_{\text{edge,low}})/2$  during the *transmitter OFF period*.  $N$  is equal to 1 if there are any UTRA or E-UTRA carriers, or for NR  $N = \text{SCS}/15$ , where SCS is the smallest supported Sub Carrier Spacing in kHz in the *Aggregated BS Channel Bandwidth*.

### 6.4.2.2 Minimum requirement for MSR operation

The transmitter OFF power spectral density shall be less than -85 dBm/MHz.

### 6.4.2.3 Minimum requirement for single RAT UTRA operation

The minimum requirement for UTRA operation is the same as that defined in subclause 6.4.2.2.

### 6.4.2.4 Minimum requirement for single RAT E-UTRA operation

The minimum requirement for UTRA operation is the same as that defined in subclause 6.4.2.2.

## 6.4.3 Transmitter transient period

### 6.4.3.1 General

The *transmitter transient period* is the time period during which the transmitter unit is changing from the OFF period to the ON period or vice versa. The *transmitter transient period* is illustrated in figure 6.4.3.1-1.

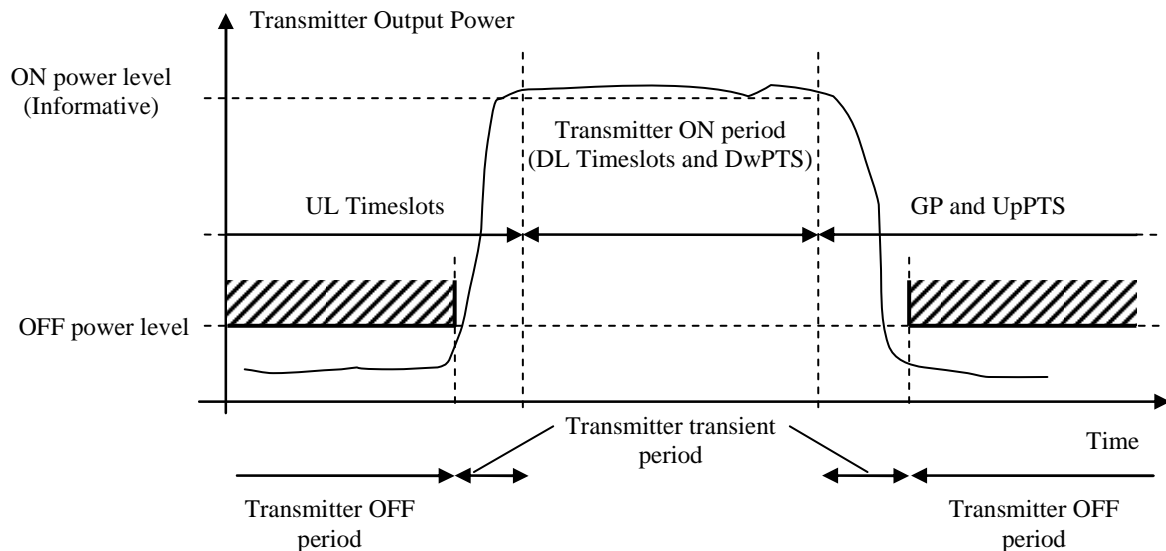

**Figure 6.4.3.1-1: Illustration of the relations of *transmitter ON period*, *transmitter OFF period* and *transmitter transient period***

This requirement applies at each *TAB connector* supporting transmission in the operating band.

#### 6.4.3.2 Minimum requirement for MSR operation

The minimum requirements for MSR AAS BS *transmitter transient period* are the same as in 3GPP TS 37.104 [9], subclause 6.4.2.1.

#### 6.4.3.3 Minimum requirement for single RAT UTRA operation

The minimum requirements for single RAT AAS BS *transmitter transient period* are the same as in 3GPP TS 25.105 [7], subclause 6.5.2.1.2.

#### 6.4.3.4 Minimum requirement for single RAT E-UTRA operation

The minimum requirements for single RAT AAS BS *transmitter transient period* are the same as in 3GPP TS 36.104 [8], subclause 6.4.2.1.

## 6.5 Transmitted signal quality

### 6.5.1 General

Unless otherwise stated, the requirements in clause 6.5 apply during the *transmitter ON period*.

### 6.5.2 Frequency Error

#### 6.5.2.1 General

This requirement applies per *TAB connector*.

Frequency error is the measure of the difference between the actual AAS BS transmit frequency and the assigned frequency. The same source shall be used for RF frequency and data clock generation.

#### 6.5.2.2 Minimum requirement for MSR operation

The minimum requirement for a UTRA frequency error is the same as defined in subclause 6.5.2.3.

The minimum requirement for an E-UTRA frequency error is the same as defined in subclause 6.5.2.4.

The minimum requirement for an NR frequency error is the same as those for *BS type I-H* defined in 3GPP TS 38.104 [28] subclause 6.5.1.2.

### 6.5.2.3 Minimum requirement for single RAT UTRA operation

The single RAT UTRA FDD AAS BS of wide area BS class shall fulfil the frequency error minimum requirements for wide area BS described in 3GPP TS 25.104 [6], subclause 6.3.1.

The single RAT UTRA FDD AAS BS of medium range BS class shall fulfil the frequency error minimum requirements for medium range BS described in 3GPP TS 25.104 [6], subclause 6.3.1.

The single RAT UTRA FDD AAS BS of local area BS class shall fulfil the frequency error minimum requirements for local area BS described in 3GPP TS 25.104 [6], subclause 6.3.1.

The single RAT UTRA TDD 1,28Mcps option AAS BS of wide area BS class shall fulfil the frequency error minimum requirements for wide area BS described in 3GPP TS 25.105 [7], subclause 6.3.1.2.

The single RAT UTRA TDD 1,28Mcps option AAS BS of local area BS class shall fulfil the frequency error minimum requirements for local area BS described in 3GPP TS 25.105 [7], subclause 6.3.1.2.

### 6.5.2.4 Minimum requirement for single RAT E-UTRA operation

The single RAT E-UTRA AAS BS of wide area BS class shall fulfil the frequency error minimum requirements for wide area BS described in 3GPP TS 36.104 [8], subclause 6.5.1.1.

The single RAT E-UTRA AAS BS of medium range BS class shall fulfil the frequency error minimum requirements for medium range BS described in 3GPP TS 36.104 [8], subclause 6.5.1.1.

The single RAT E-UTRA AAS BS of local area BS class shall fulfil the frequency error minimum requirements for local area BS described in 3GPP TS 36.104 [8], subclause 6.5.1.1.

## 6.5.3 Time alignment error

### 6.5.3.1 General

This requirement applies to frame timing in:

- UTRA single/multi-carrier transmissions and their combinations with MIMO or TX diversity.
- E-UTRA single/multi-carrier transmissions and their combinations with MIMO or TX diversity.
- E-UTRA *carrier aggregation*, with or without MIMO or TX diversity.
- NR single/multi-carrier transmissions, and their combinations with MIMO.
- NR Carrier Aggregation, with or without MIMO.

Frames of the WCDMA/LTE/NR signals present at the *TAB connectors* are not perfectly aligned in time. In relation to each other, the RF signals present at the *transceiver array boundary* may experience certain timing differences.

For a specific set of signals/transmitter configuration/transmission mode, the Time Alignment Error (TAE) is defined as the largest timing difference between any two different LTE signals or any two different WCDMA signals or any two different NR signals belonging to different *TAB Connectors* belonging to different transmitter groups at the *transceiver array boundary*, where transmitter groups are associated with the *TAB connectors* in the transceiver unit array corresponding to TX diversity (except NR), MIMO transmission, *carrier aggregation*, etc.

### 6.5.3.2 Minimum requirement for MSR operation

The minimum requirement for a UTRA time alignment error is the same as defined in subclause 6.5.3.3.

The minimum requirement for an E-UTRA time alignment error is the same as defined in subclause 6.5.3.4.

The minimum requirement for an NR time alignment error is the same as those for *BS type 1-H* defined in 3GPP TS 38.104[28] in subclause 6.5.1.2.

### 6.5.3.3 Minimum requirement for single RAT UTRA operation

This requirement applies to frame timing in Tx diversity, MIMO transmission, DC-HSDPA, DB-DC-HSDPA, 4C-HSDPA, NC-4C-HSDPA, 8C-HSDPA and their combinations.

The TAE between any two *TAB connectors* from different transmitter groups shall not exceed the specified minimum requirements below.

For UTRA FDD, the minimum requirement for time alignment are the same as those in 3GPP TS 25.104 [6], subclause 6.8.4.1.

For UTRA TDD, the minimum requirement for time alignment are the same as those in 3GPP TS 25.105 [7], subclause 6.8.5.1.

### 6.5.3.4 Minimum requirement for single RAT E-UTRA operation

This requirement applies to frame timing in TX diversity, MIMO transmission, *carrier aggregation* and their combinations.

The TAE between any two *TAB connectors* from different transmitter groups shall not exceed the specified minimum requirements below.

For E-UTRA, the minimum requirement for time alignment are the same as those in 3GPP TS 36.104 [8], subclause 6.5.3.1.

## 6.5.4 Modulation quality

### 6.5.4.1 General

Modulation quality is defined by the difference between the measured carrier signal and an ideal signal. Modulation quality can be expressed e.g. as Peak Code domain Error (PCDE) or Relative Code domain Error (RCDE) or Error Vector Magnitude (EVM) for UTRA and Error Vector Magnitude (EVM) for E-UTRA.

These requirements apply per *TAB connector*.

### 6.5.4.2 Minimum requirement for MSR operation

The minimum requirement for a UTRA modulation quality are defined in subclause 6.5.4.3.

The minimum requirement for an E-UTRA modulation quality are defined in subclause 6.5.4.4.

The minimum requirement for an NR modulation quality is defined as the same as those for *BS type 1-H* in 3GPP TS 38.104 [28] in subclause 6.5.2.2.

### 6.5.4.3 Minimum requirement for single RAT UTRA operation

The Error Vector Magnitude is a measure of the difference between the ideal waveform and the measured waveform. This difference is called the error vector. Both waveforms pass through a matched Root Raised Cosine filter to the considered chip rate and roll-off  $\alpha=0.22$ . Both waveforms are then further modified by selecting the frequency, absolute phase, absolute amplitude and chip clock timing to minimize the error vector. The EVM result is defined as the square root of the ratio of the mean error vector power to the mean reference power expressed as a %.

For UTRA FDD the measurement interval is one timeslot as defined by the C-PICH (when present) otherwise the measurement interval is one timeslot starting with the beginning of the SCH. The requirement is valid over the total power dynamic range as specified in subclause 6.3.4.3. The minimum requirements are the same as those in 3GPP TS 25.104 [6], subclause 6.8.2.1.

For UTRA TDD the measurement interval is one timeslot. The requirement is valid over the total power dynamic range as specified in subclause 6.3.4.3. See annex C of 3GPP TS 25.142 [10] for further details. The minimum requirements are the same as those in 3GPP TS 25.105 [7], subclause 6.8.2.1.

For UTRA FDD the Peak Code Domain Error is computed by projecting the error vector onto the code domain at a specified spreading factor. The Code Domain Error for every code in the domain is defined as the ratio of the mean power of the projection onto that code, to the mean power of the composite ideal waveform. This ratio is expressed in dB. The Peak Code Domain Error is defined as the maximum value for the Code Domain Error for all codes. The measurement interval is one timeslot as defined by the C-PICH (when present) otherwise the measurement interval is one timeslot starting with the beginning of the SCH. The minimum requirements are the same as those in 3GPP TS 25.104 [6], subclause 6.8.3.1.

For UTRA FDD the Relative Code Domain Error is computed by projecting the error vector onto the code domain at a specified spreading factor. Only the active code channels in the composite ideal waveform are considered for this requirement. The Relative Code Domain Error for every active code is defined as the ratio of the mean power of the error projection onto that code, to the mean power of the active code in the composite ideal waveform. This ratio is expressed in dB. The measurement interval is one frame. The minimum requirements are the same as those in 3GPP TS 25.104 [6], subclause 6.8.5.1.

For UTRA TDD 1,28Mcps option, the minimum requirements for modulation quality, PCDE and RCDE, are the same as in 3GPP TS 25.105 [7], subclauses 6.8.2, 6.8.3 and 6.8.4 respectively. The requirement for Relative Code Domain Error is only applicable for 64QAM modulated codes (UTRA FDD and UTRA TDD).

#### 6.5.4.4 Minimum requirement for single RAT E-UTRA operation

For E-UTRA, the minimum requirement for modulation quality, EVM, is specified in 3GPP TS 36.104 [8], subclause 6.5.2.

### 6.5.5 Transmit pulse shape filter

#### 6.5.5.1 General

Transmit pulse shape filter for *single RAT UTRA operation* in FDD and for *MSR operation* in UTRA FDD is defined in 3GPP TS 25.104 [6] subclause 6.8.1.

Transmit pulse shape filter for *single RAT UTRA operation* in TDD and for *MSR operation* in UTRA TDD is defined in 3GPP TS 25.105 [7] subclause 6.8.1.

Transmit pulse shape filter is not defined for a *single RAT E-UTRA operation*, nor for *MSR operation* using E-UTRA and/or NR.

6.5.5.2 Void

6.5.5.3 Void

6.5.5.4 Void

## 6.6 Unwanted Emissions

### 6.6.1 General

Unwanted emissions consist of so-called out-of-band emissions and spurious emissions according to ITU definitions ITU-R SM.329 [14]. In ITU terminology, out of band emissions are unwanted emissions immediately outside the *channel bandwidth* resulting from the modulation process and non-linearity in the transmitter but excluding spurious emissions. Spurious emissions are emissions which are caused by unwanted transmitter effects such as harmonics emission, parasitic emission, intermodulation products and frequency conversion products, but exclude out of band emissions.

For AAS BS in *single RAT E-UTRA operation* and *MSR operation*, the out-of-band emissions requirement for the AAS BS transmitter is specified in terms of an operating band unwanted emissions requirement that defines limits for emissions in each supported *downlink operating band* plus the frequency ranges  $\Delta f_{\text{OBUE}}$  above and  $\Delta f_{\text{OBUE}}$  below each band, where  $\Delta f_{\text{OBUE}}$  is the maximum offset of the operating band unwanted emission mask from the operating band edge. Emissions outside of this frequency range are limited by a spurious emissions requirement. For UTRA FDD single RAT AAS BS, the out of band emission requirement for AAS BS transmitter is specified in terms of spectrum emission mask requirement.

The values of  $\Delta f_{\text{OBUE}}$  are defined for *hybrid AAS BS* for E-UTRA and UTRA operating bands in Table 6.6.1-1.

**Table 6.6.1-1: Maximum offset of OBUE outside the downlink operating band**

BS type	Operating band characteristics	$\Delta f_{\text{OBUE}}$ [MHz]
Hybrid AAS BS	$F_{\text{DL\_high}} - F_{\text{DL\_low}} < 100$ MHz	10
	$100 \text{ MHz} \leq F_{\text{DL\_high}} - F_{\text{DL\_low}} \leq 900$ MHz	40

The unwanted emission level limit of a *TAB connector TX min cell group* is in general defined by the unwanted emission *basic limit* which is the same as the corresponding applicable *non-AAS BS* per transmitter requirement specified in 3GPP TS 25.104 [2], 3GPP TS 25.105 [3], 3GPP TS 36.104 [4] or 3GPP TS 37.104 [5], and its scaling by  $N_{\text{TXU, counted per cell}}$ . The unwanted emission requirements are applied per the *TAB connector TX min cell groups* for all the configurations supported by the AAS BS. The *basic limits* and corresponding scaling are defined in each relevant subclause.

There is in addition a requirement for occupied bandwidth and an ACLR requirement.

## 6.6.2 Occupied bandwidth

### 6.6.2.1 General

The occupied bandwidth is the width of a frequency band such that, below the lower and above the upper frequency limits, the mean powers emitted are each equal to a specified percentage  $\beta/2$  of the total mean transmitted power. See also Recommendation ITU-R SM.328 [17].

The value of  $\beta/2$  shall be taken as 0.5%.

The occupied bandwidth requirement applies during the *transmitter ON period* for a single transmitted carrier. The minimum requirement below may be applied regionally. There may also be regional requirements to declare the occupied bandwidth according to the definition in the present clause.

### 6.6.2.2 Minimum requirement for MSR operation

For MSR AAS BS, the minimum requirement for occupied bandwidth is the same as that stated in 3GPP TS 37.104 [9], subclause 6.6.3.

### 6.6.2.3 Minimum requirement for single RAT UTRA operation

For single RAT UTRA FDD AAS BS, the minimum requirement for occupied bandwidth is the same as that stated in 3GPP TS 25.104 [6] subclause 6.6.1.

For single RAT UTRA TDD, 1,28Mcps option AAS BS, the minimum requirement for occupied bandwidth is the same as that stated in 3GPP TS 25.105 [7], subclause 6.6.1.

### 6.6.2.4 Minimum requirement for single RAT E-UTRA operation

For single RAT E-UTRA AAS BS, the minimum requirement for occupied bandwidth is the same as that stated in 3GPP TS 36.104 [8], subclause 6.6.1.

## 6.6.3 Adjacent Channel Leakage power Ratio

### 6.6.3.1 General

Adjacent Channel Leakage power Ratio (ACLR) is the ratio of the filtered mean power centred on the assigned channel frequency to the filtered mean power centred on an adjacent channel frequency.

NOTE: Conformance to the AAS BS ACLR requirement can be demonstrated by meeting at least one of the following criteria as determined by the manufacturer:

- 1) The ratio of the sum of the filtered mean power measured on each *TAB connector* in the *TAB connector TX min cell group* at the assigned channel frequency to the sum of the filtered mean power measured on each *TAB connector* in the *TAB connector TX min cell group* at the adjacent channel frequency shall be greater than or equal to the ACLR limit of AAS BS. This applies for each *TAB connector TX min cell group*.

Or

- 2) The ratio of the filtered mean power at the *TAB connector* centred on the assigned channel frequency to the filtered mean power at each *TAB connector* centred on the adjacent channel frequency shall be greater than or equal to the ACLR limit of AAS BS for every *TAB connector* in the *TAB connector TX min cell group*, for each *TAB connector TX min cell group*.

In case the ACLR absolute limit of AAS BS is applied, the conformance can be demonstrated by meeting at least one of the following criteria as determined by the manufacturer:

- 1) The sum of the filtered mean power measured on each *TAB connector* in the *TAB connector TX min cell group* at the adjacent channel frequency shall be less than or equal to the ACLR absolute limit AAS BS. This applies to each *TAB connector TX min cell group*.

Or

- 2) The filtered mean power at each *TAB connector* centred on the adjacent channel frequency shall be less than or equal to the ACLR absolute limit of AAS BS scaled by  $-10\log_{10}(n)$  for every *TAB connector* in the *TAB connector TX min cell group*, for each *TAB connector TX min cell group*, where  $n$  is the number of *TAB connectors* in the *TAB connector TX min cell group*.

### 6.6.3.2 Minimum requirement for MSR operation

For E-UTRA and/or NR MSR operation, the ACLR limits for AAS BS are the same as those specified in 3GPP TS 37.104 [9] subclauses 6.6.4.1. The *basic limits* are also the same as the absolute limits of MSR E-UTRA and/or NR operation specified in 3GPP TS 37.104 [9] subclauses 6.6.4.1. The ACLR absolute limit of AAS BS is specified as the *basic limit* +  $10\log_{10}(N_{\text{TXU, counted per cell}})$ . The ACLR limit or the ACLR absolute limit of AAS BS, whichever is less stringent, shall apply outside the *Base Station RF Bandwidth* or *Radio Bandwidth*.

For UTRA FDD operation, the minimum requirement for ACLR are the same as those specified in 3GPP TS 25.104 [6], subclause 6.6.2.2, and applies outside the *Base Station RF Bandwidth* or *Radio Bandwidth*.

For UTRA TDD 1,28 Mcps operation, the minimum requirement for ACLR are the same as those specified in 3GPP TS 25.105 [7], subclause 6.6.2.2.1.2, and applies outside the *Base Station RF Bandwidth* or *Radio Bandwidth*.

For a *TAB connector* or *TAB connector cell group* supporting operation in *non-contiguous spectrum*, the ACLR requirement also applies for the first adjacent channel inside any *sub-block gap* with a gap size  $W_{\text{gap}} \geq 15\text{MHz}$ . The ACLR requirement for the second adjacent channel applies inside any *sub-block gap* with a gap size  $W_{\text{gap}} \geq 20\text{MHz}$ .

CACLR requirements apply in *sub-block gaps* as defined in 3GPP TS 37.104 [9], subclause 6.6.4.4. Either the CACLR limit or the ACLR absolute limit of AAS BS shall apply, whichever is less stringent.

For a *multi-band TAB connector* or *TAB connector cell group* supporting operation in multiple operating bands through *multi-band TAB connectors*, the ACLR requirement also applies for the first adjacent channel inside any *Inter RF Bandwidth gap* with a gap size  $W_{\text{gap}} \geq 15\text{MHz}$ . The ACLR requirement for the second adjacent channel applies inside any *Inter RF Bandwidth gap* with a gap size  $W_{\text{gap}} \geq 20\text{MHz}$ .

CACLR requirements apply in *Inter RF Bandwidth gaps* as defined in 3GPP TS 37.104 [9], subclause 6.6.4.4. Either the CACLR limit or the ACLR absolute limit of AAS BS shall apply, whichever is less stringent.

### 6.6.3.3 Minimum requirement for single RAT UTRA operation

For single RAT UTRA FDD operation, the AAS BS ACLR minimum requirements are the same as those specified in 3GPP TS 25.104 [6], subclauses 6.6.2.2.1.

For single RAT UTRA FDD operation, the AAS BS CACLR limits are the same as those specified in 3GPP TS 25.104 [6], subclauses 6.6.2.2.2. The *basic limits* are also the same as the absolute limits of UTRA specified in 3GPP TS 25.104 [6], subclauses 6.6.2.2.2. The ACLR (CACLR) absolute *basic limits* of AAS BS are specified as the *basic limit* +  $10\log_{10}(N_{\text{TXU, countedpercell}})$ . The ACLR (CACLR) limit or the ACLR (CACLR) absolute *basic limit* of AAS BS shall apply, whichever is less stringent.

For single RAT UTRA TDD 1,28 Mcps operation, the AAS BS minimum requirements are the same as those specified in 3GPP TS 25.105 [7], subclause 6.6.2.2.

### 6.6.3.4 Minimum requirement for single RAT E-UTRA operation

For *single RAT E-UTRA operation*, the AAS BS ACLR and CACLR limits are the same as those specified in 3GPP TS 36.104 [8], subclauses 6.6.2.1 and 6.6.2.2. The *basic limits* are also the same as the absolute limits of E-UTRA specified in 3GPP TS 36.104 [8], subclauses 6.6.2.1 and 6.6.2.2. The ACLR (CACLR) absolute *basic limits* of AAS BS are specified as the *basic limit* +  $10\log_{10}(N_{\text{TXU, countedpercell}})$ . The ACLR (CACLR) limit or the ACLR (CACLR) absolute *basic limit* of AAS BS shall apply, whichever is less stringent.

## 6.6.4 Spectrum emission mask

### 6.6.4.1 General

This requirement is applicable for single RAT UTRA AAS BS operation only.

### 6.6.4.2 Minimum requirement for MSR operation

There is no spectrum emission mask requirement for an MSR AAS BS.

### 6.6.4.3 Minimum requirement for single RAT UTRA operation

#### 6.6.4.3.1 General

The spectrum emission mask requirements for a UTRA single RAT AAS BS are that for each applicable *basic limit* as specified in 3GPP TS 25.104 [2] or TS 25.105 [7], and for each *TAB connector TX min cell group* the power sum of emissions at the *TAB connectors* of the *TAB connector TX min cell group* shall not exceed an AAS BS limit specified as the *basic limits* +  $10\log_{10}(N_{\text{TXU, countedpercell}})$ .

NOTE: Conformance to the AAS BS spectrum emission mask requirement can be demonstrated by meeting at least one of the following criteria as determined by the manufacturer:

- 1) The sum of the emissions power measured on each *TAB connector* in the *TAB connector TX min cell group* shall be less than or equal to the AAS limit as defined in this subclause for the respective frequency span.

Or

- 2) The spectrum emission mask power at each *TAB connector* shall be less than or equal to the AAS BS limit as defined in this subclause for the respective frequency span, scaled by  $-10\log_{10}(n)$ , where  $n$  is the number of *TAB connectors* in the *TAB connector TX min cell group*.

#### 6.6.4.3.2 Basic limits for single RAT UTRA FDD operation

The *basic limit* is specified in tables 6.6.4.3.2-1 to 6.6.4.3.2-10 for the appropriate  $P_{\text{Rated, c, sys}}$ , where:

- $\Delta f$  is the separation between the carrier frequency and the nominal -3 dB point of the measuring filter closest to the carrier frequency.
- $f_{\text{offset}}$  is the separation between the carrier frequency and the centre of the measurement filter;
- $f_{\text{offset}_{\text{max}}}$  is either 12.5 MHz or the offset to the UMTS Tx band edge as defined in clause 5.2, whichever is the greater.
- $\Delta f_{\text{max}}$  is equal to  $f_{\text{offset}_{\text{max}}}$  minus half of the bandwidth of the measuring filter.

Inside any *Inter RF Bandwidth gaps* with  $W_{\text{gap}} < 2 \times \Delta f_{\text{OBUE}}$  for a *multi-band TAB connector*, emissions shall not exceed the cumulative sum of the *basic limits* specified at the *Base Station RF Bandwidth edges* on each side of the *Inter RF Bandwidth gap*. The *basic limit* for *Base Station RF Bandwidth edge* is specified in tables 6.6.4.3.2-1 to 6.6.4.3.2-10 below, where in this case:

- $\Delta f$  is equal to 2.5MHz plus the separation between the *Base Station RF Bandwidth edge* frequency and the nominal -3dB point of the measuring filter closest to the *Base Station RF Bandwidth edge*.
- $f_{\text{offset}}$  is equal to 2.5MHz plus the separation between the *Base Station RF Bandwidth edge* frequency and the centre of the measuring filter.
- $f_{\text{offset}_{\text{max}}}$  is either 12.5 MHz or the offset to the UMTS Tx band edge as defined in clause 5.2, whichever is the greater.
- $\Delta f_{\text{max}}$  is equal to  $f_{\text{offset}_{\text{max}}}$  minus half of the bandwidth of the measuring filter.

For a *multi-band TAB connector*, the operating band unwanted emission *basic limits* apply also in a supported operating band without any carrier transmitted, in the case where there are carrier(s) transmitted in another supported operating band. In this case, no cumulative limit is applied in the *inter-band gap* between a supported *downlink operating band* with carrier(s) transmitted and a supported *downlink operating band* without any carrier transmitted and

- In case the *inter-band gap* between a downlink band with carrier(s) transmitted and a downlink band without any carrier transmitted is less than  $2 \times \Delta f_{\text{OBUE}}$ ,  $f_{\text{offset}_{\text{max}}}$  shall be the offset to the frequency  $\Delta f_{\text{OBUE}}$  outside the outermost edges of the two *downlink operating bands* and the operating band unwanted emission limit of the band where there are carriers transmitted, as defined in the tables of the present subclause, shall apply across both downlink bands.
- In other cases, the operating band unwanted emission limit of the band where there are carriers transmitted, as defined in the tables of the present subclause for the largest frequency offset ( $\Delta f_{\text{max}}$ ), shall apply from  $\Delta f_{\text{OBUE}}$  below the lowest frequency, up to  $\Delta f_{\text{OBUE}}$  above the highest frequency of the *downlink operating band* without any carrier transmitted.

Inside any *sub-block gap* for a *TAB connector* operating in *non-contiguous spectrum*, emissions shall not exceed the cumulative sum of the *basic limits* specified for the adjacent sub blocks on each side of the *sub-block gap*. The *basic limit* for each sub block is specified in tables 6.6.4.3.2-1 to 6.6.4.3.2-10 below, where in this case:

- $\Delta f$  is equal to 2.5MHz plus the separation between the sub block edge frequency and the nominal -3 dB point of the measuring filter closest to the sub block edge.
- $f_{\text{offset}}$  is equal to 2.5MHz plus the separation between the sub block edge frequency and the centre of the measuring filter.
- $f_{\text{offset}_{\text{max}}}$  is equal to the *sub-block gap* bandwidth minus half of the bandwidth of the measuring filter plus 2.5MHz.
- $\Delta f_{\text{max}}$  is equal to  $f_{\text{offset}_{\text{max}}}$  minus half of the bandwidth of the measuring filter.

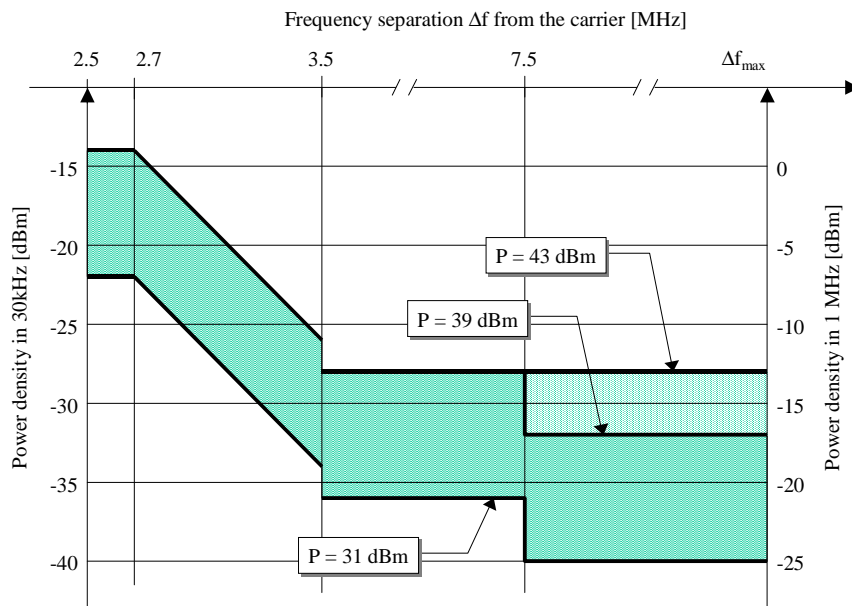

Illustrative diagram of spectrum emission mask

Figure 6.6.4.3.2-1: Spectrum emission mask

Table 6.6.4.3.2-1: Spectrum emission mask values,  $P_{\text{rated,c,cell}} - 10 \cdot \log_{10}(N_{\text{TXU,countedpercell}}) \geq 43$  dBm for UTRA FDD

Frequency offset of measurement filter - 3 dB point, Δf	Frequency offset of measurement filter centre frequency, f_offset	Basic limit (NOTE 1, 2)	Measurement bandwidth (NOTE 4)
$2.5 \text{ MHz} \leq \Delta f < 2.7 \text{ MHz}$	$2.515 \text{ MHz} \leq f_{\text{offset}} < 2.715 \text{ MHz}$	-14 dBm	30 kHz
$2.7 \text{ MHz} \leq \Delta f < 3.5 \text{ MHz}$	$2.715 \text{ MHz} \leq f_{\text{offset}} < 3.515 \text{ MHz}$	$-14 \text{ dBm} - 15 \cdot \left( \frac{f_{\text{offset}} - 2.715}{\text{MHz}} \right) \text{ dB}$	30 kHz
(NOTE 3)	$3.515 \text{ MHz} \leq f_{\text{offset}} < 4.0 \text{ MHz}$	-26 dBm	30 kHz
$3.5 \text{ MHz} \leq \Delta f < 7.5 \text{ MHz}$	$4.0 \text{ MHz} \leq f_{\text{offset}} < 8.0 \text{ MHz}$	-13 dBm	1 MHz
$7.5 \text{ MHz} \leq \Delta f \leq \Delta f_{\text{max}}$	$8.0 \text{ MHz} \leq f_{\text{offset}} < f_{\text{offset}_{\text{max}}}$	-13 dBm	1 MHz

NOTE 1: For a TAB connector supporting non-contiguous spectrum operation the basic limit within sub-block gaps within any operating band is calculated as a cumulative sum of contributions from adjacent sub blocks on each side of the sub-block gap, where the contribution from the far-end sub-block shall be scaled according to the measurement bandwidth of the near-end sub-block. Exception is  $\Delta f \geq 12.5 \text{ MHz}$  from both adjacent sub blocks on each side of the sub-block gap, where the spurious emission basic limits in clause 6.6.6.5.2.2 and 6.6.6.5.5.3 shall be met.

NOTE 2: For a multi-band TAB connector with Inter RF Bandwidth gap <  $2 \times \Delta f_{\text{OBUE}}$  the basic limit within the Inter RF Bandwidth gaps is calculated as a cumulative sum of contributions from adjacent sub-blocks or Base Station RF Bandwidth on each side of the Inter RF Bandwidth gap, where the contribution from the far-end sub-block or Base Station RF Bandwidth shall be scaled according to the measurement bandwidth of the near-end sub-block or Base Station RF Bandwidth.

**Table 6.6.4.3.2-2: Spectrum emission mask values,  $39 \text{ dBm} \leq P_{\text{rated,c,cell}} - 10 \cdot \log_{10}(N_{\text{TXU,countedpercell}}) < 43 \text{ dBm}$  for UTRA FDD bands**

Frequency offset of measurement filter -3 dB point, $\Delta f$	Frequency offset of measurement filter centre frequency, $f_{\text{offset}}$	Basic limit (NOTE 1, 2)	Measurement bandwidth (NOTE 4)
$2.5 \text{ MHz} \leq \Delta f < 2.7 \text{ MHz}$	$2.515 \text{ MHz} \leq f_{\text{offset}} < 2.715 \text{ MHz}$	-14 dBm	30 kHz
$2.7 \text{ MHz} \leq \Delta f < 3.5 \text{ MHz}$	$2.715 \text{ MHz} \leq f_{\text{offset}} < 3.515 \text{ MHz}$	$-14 \text{ dBm} - 15 \cdot \left( \frac{f_{\text{offset}}}{\text{MHz}} - 2.715 \right) \text{ dB}$	30 kHz
(NOTE 3)	$3.515 \text{ MHz} \leq f_{\text{offset}} < 4.0 \text{ MHz}$	-26 dBm	30 kHz
$3.5 \text{ MHz} \leq \Delta f < 7.5 \text{ MHz}$	$4.0 \text{ MHz} \leq f_{\text{offset}} < 8.0 \text{ MHz}$	-13 dBm	1 MHz
$7.5 \text{ MHz} \leq \Delta f \leq \Delta f_{\text{max}}$	$8.0 \text{ MHz} \leq f_{\text{offset}} < f_{\text{offset}_{\text{max}}}$	$P_{\text{rated,c,cell}} - 10 \cdot \log_{10}(N_{\text{TXU,countedpercell}}) - 56 \text{ dB}$	1 MHz
<p>NOTE 1: For a TAB connector supporting <i>non-contiguous spectrum</i> operation the <i>basic limit</i> within <i>sub-block gaps</i> within any operating band is calculated as a cumulative sum of contributions from adjacent sub blocks on each side of the <i>sub-block gap</i>, where the contribution from the far-end sub-block shall be scaled according to the measurement bandwidth of the near-end sub-block. Exception is <math>\Delta f \geq 12.5 \text{ MHz}</math> from both adjacent sub blocks on each side of the <i>sub-block gap</i>, where the spurious emission <i>basic limit</i> in clause 6.6.6.5.2.2 and 6.6.6.5.3 shall be met.</p> <p>NOTE 2: For a <i>multi-band TAB connector</i> with <i>Inter RF Bandwidth gap</i> <math>&lt; 2 \times \Delta f_{\text{OBU E}}</math> the <i>basic limit</i> within the <i>Inter RF Bandwidth gaps</i> is calculated as a cumulative sum of contributions from adjacent sub-blocks or <i>Base Station RF Bandwidth</i> on each side of the <i>Inter RF Bandwidth gap</i>, where the contribution from the far-end sub-block or <i>Base Station RF Bandwidth</i> shall be scaled according to the measurement bandwidth of the near-end sub-block or <i>Base Station RF Bandwidth</i>.</p>			

**Table 6.6.4.3.2-3: Spectrum emission mask values,  $31 \text{ dBm} \leq P_{\text{rated,c,cell}} - 10 \cdot \log_{10}(N_{\text{TXU,countedpercell}}) < 39 \text{ dBm}$  for UTRA FDD bands**

Frequency offset of measurement filter - 3 dB point, $\Delta f$	Frequency offset of measurement filter centre frequency, $f_{\text{offset}}$	Basic limit (NOTE 1, 2)	Measurement bandwidth (NOTE 4)
$2.5 \text{ MHz} \leq \Delta f < 2.7 \text{ MHz}$	$2.515 \text{ MHz} \leq f_{\text{offset}} < 2.715 \text{ MHz}$	$P_{\text{rated,c,cell}} - 10 \cdot \log_{10}(N_{\text{TXU,countedpercell}}) - 53 \text{ dB}$	30 kHz
$2.7 \text{ MHz} \leq \Delta f < 3.5 \text{ MHz}$	$2.715 \text{ MHz} \leq f_{\text{offset}} < 3.515 \text{ MHz}$	$P_{\text{rated,c,cell}} - 10 \cdot \log_{10}(N_{\text{TXU,countedpercell}}) - 53 \text{ dB} - 15 \cdot (f_{\text{offset}}/\text{MHz} - 2.715) \text{ dB}$	30 kHz
(NOTE 3)	$3.515 \text{ MHz} \leq f_{\text{offset}} < 4.0 \text{ MHz}$	$P_{\text{rated,c,cell}} - 10 \cdot \log_{10}(N_{\text{TXU,countedpercell}}) - 65 \text{ dB}$	30 kHz
$3.5 \text{ MHz} \leq \Delta f < 7.5 \text{ MHz}$	$4.0 \text{ MHz} \leq f_{\text{offset}} < 8.0 \text{ MHz}$	$P_{\text{rated,c,cell}} - 10 \cdot \log_{10}(N_{\text{TXU,countedpercell}}) - 52 \text{ dB}$	1 MHz
$7.5 \text{ MHz} \leq \Delta f \leq \Delta f_{\text{max}}$	$8.0 \text{ MHz} \leq f_{\text{offset}} < f_{\text{offset}_{\text{max}}}$	$P_{\text{rated,c,cell}} - 10 \cdot \log_{10}(N_{\text{TXU,countedpercell}}) - 56 \text{ dB}$	1 MHz
<p>NOTE 1: For a TAB connector supporting <i>non-contiguous spectrum</i> operation the <i>basic limit</i> within <i>sub-block gaps</i> within any operating band is calculated as a cumulative sum of contributions from adjacent sub blocks on each side of the <i>sub-block gap</i>, where the contribution from the far-end sub-block shall be scaled according to the measurement bandwidth of the near-end sub-block. Exception is <math>\Delta f \geq 12.5 \text{ MHz}</math> from both adjacent sub blocks on each side of the <i>sub-block gap</i>, where the spurious emission <i>basic limits</i> in clause 6.6.6.5.2.2 and 6.6.6.5.3 shall be met.</p> <p>NOTE 2: For a <i>multi-band TAB connector</i> with <i>Inter RF Bandwidth gap</i> <math>&lt; 2 \times \Delta f_{\text{OBU E}}</math> the <i>basic limit</i> within the <i>Inter RF Bandwidth gaps</i> is calculated as a cumulative sum of contributions from adjacent sub-blocks or <i>Base Station RF Bandwidth</i> on each side of the <i>Inter RF Bandwidth gap</i>, where the contribution from the far-end sub-block or <i>Base Station RF Bandwidth</i> shall be scaled according to the measurement bandwidth of the near-end sub-block or <i>Base Station RF Bandwidth</i>.</p>			

**Table 6.6.4.3.2-4: Spectrum emission mask values,  $P_{\text{rated,c,cell}} - 10 \cdot \log_{10}(N_{\text{TXU,countedpercell}}) < 31$  dBm for UTRA FDD bands**

Frequency offset of measurement filter - 3 dB point, $\Delta f$	Frequency offset of measurement filter centre frequency, $f_{\text{offset}}$	Basic limit (NOTE 1, 2)	Measurement bandwidth (NOTE 4)
$2.5 \text{ MHz} \leq \Delta f < 2.7 \text{ MHz}$	$2.515\text{MHz} \leq f_{\text{offset}} < 2.715\text{MHz}$	-22 dBm	30 kHz
$2.7 \leq \Delta f < 3.5 \text{ MHz}$	$2.715\text{MHz} \leq f_{\text{offset}} < 3.515\text{MHz}$	$-22\text{dBm} - 15 \cdot \left( \frac{f_{\text{offset}}}{\text{MHz}} - 2.715 \right) \text{dB}$	30 kHz
(NOTE 3)	$3.515\text{MHz} \leq f_{\text{offset}} < 4.0\text{MHz}$	-34 dBm	30 kHz
$3.5 \text{ MHz} \leq \Delta f < 7.5 \text{ MHz}$	$4.0 \text{ MHz} \leq f_{\text{offset}} < 8.0\text{MHz}$	-21 dBm	1 MHz
$7.5 \text{ MHz} \leq \Delta f \leq \Delta f_{\text{max}}$	$8.0\text{MHz} \leq f_{\text{offset}} < f_{\text{offset}_{\text{max}}}$	-25 dBm	1 MHz

NOTE 1: For a TAB connector supporting non-contiguous spectrum operation the basic limit within sub-block gaps within any operating band is calculated as a cumulative sum of contributions from adjacent sub blocks on each side of the sub-block gap, where the contribution from the far-end sub-block shall be scaled according to the measurement bandwidth of the near-end sub-block. Exception is  $\Delta f \geq 12.5\text{MHz}$  from both adjacent sub blocks on each side of the sub-block gap, where the spurious emission basic limits in clause 6.6.6.5.2.2 and 6.6.6.5.5.3 shall be met.

NOTE 2: For a multi-band TAB connector with Inter RF Bandwidth gap  $< 2 \times \Delta f_{\text{OBUE}}$  the basic limit within the Inter RF Bandwidth gaps is calculated as a cumulative sum of contributions from adjacent sub-blocks or Base Station RF Bandwidth on each side of the Inter RF Bandwidth gap, where the contribution from the far-end sub-block or Base Station RF Bandwidth shall be scaled according to the measurement bandwidth of the near-end sub-block or Base Station RF Bandwidth.

For operation in band II, IV, V, X, XII, XIII, XIV, XXV and XXVI, the additional requirement in tables 6.6.4.3.2-5 to 6.6.4.3.2-7 apply in addition to the basic limits in tables 6.6.4.3.2-1 to 6.6.4.3.2-4.

**Table 6.6.4.3.2-5: Additional spectrum emission basic limits for Bands II, IV, X, XXV**

Frequency offset of measurement filter -3dB point, $\Delta f$	Frequency offset of measurement filter centre frequency, $f_{\text{offset}}$	Additional basic limit	Measurement bandwidth (NOTE 4)
$2.5 \text{ MHz} \leq \Delta f < 3.5 \text{ MHz}$	$2.515\text{MHz} \leq f_{\text{offset}} < 3.515\text{MHz}$	-15 dBm	30 kHz
$3.5 \text{ MHz} \leq \Delta f \leq \Delta f_{\text{max}}$	$4.0\text{MHz} \leq f_{\text{offset}} < f_{\text{offset}_{\text{max}}}$	-13 dBm	1 MHz

**Table 6.6.4.3.2-6: Additional spectrum emission basic limits for Bands V, XXVI**

Frequency offset of measurement filter -3dB point, $\Delta f$	Frequency offset of measurement filter centre frequency, $f_{\text{offset}}$	Additional basic limit	Measurement bandwidth (NOTE 4)
$2.5 \text{ MHz} \leq \Delta f < 3.5 \text{ MHz}$	$2.515\text{MHz} \leq f_{\text{offset}} < 3.515\text{MHz}$	-15 dBm	30 kHz
$3.5 \text{ MHz} \leq \Delta f \leq \Delta f_{\text{max}}$	$3.55\text{MHz} \leq f_{\text{offset}} < f_{\text{offset}_{\text{max}}}$	-13 dBm	100 kHz

**Table 6.6.4.3.2-7: Additional spectrum emission *basic limits* for Bands XII, XIII, XIV**

Frequency offset of measurement filter -3dB point, $\Delta f$	Frequency offset of measurement filter centre frequency, $f_{\text{offset}}$	Additional <i>basic limit</i>	Measurement bandwidth (NOTE 4)
$2.5 \text{ MHz} \leq \Delta f < 2.6 \text{ MHz}$	$2.515 \text{ MHz} \leq f_{\text{offset}} < 2.615 \text{ MHz}$	-13 dBm	30 kHz
$2.6 \text{ MHz} \leq \Delta f \leq \Delta f_{\text{max}}$	$2.65 \text{ MHz} \leq f_{\text{offset}} < f_{\text{offset}_{\text{max}}}$	-13 dBm	100 kHz

In certain regions the following requirement may apply for protection of DTT. For a *TAB connector* operating in Band XX, the level of emissions in the band 470-790 MHz, measured in an 8MHz filter bandwidth on centre frequencies  $F_{\text{filter}}$  according to table 6.6.4.3.2-8, shall not exceed the maximum emission *basic limit*  $P_{\text{EM},N}$  declared by the manufacturer.

**Table 6.6.4.3.2-8: Declared emissions levels for protection of DTT**

Filter centre frequency, $F_{\text{filter}}$	Measurement bandwidth	Declared emission <i>basic limit</i> [dBm]
$F_{\text{filter}} = 8 \cdot N + 306 \text{ (MHz)}$ ; $21 \leq N \leq 60$	8 MHz	$P_{\text{EM},N}$

NOTE: The regional requirement is defined in terms of EIRP (effective isotropic radiated power), which is dependent on both the BS emissions at the antenna connector and the deployment (including antenna gain and feeder loss). The *basic limit* defined above provides the characteristics of the AAS base station needed to verify compliance with the regional requirement. Compliance with the regional requirement for protection of DTT can be determined using the method outlined in annex D of 3GPP TS 25.104 [2].

In certain regions, the following *basic limits* may apply to a *TAB connector* operating in Band XXXII within 1452-1492 MHz. The level of unwanted emissions, measured on centre frequencies  $f_{\text{offset}}$  with filter bandwidth, according to table 6.6.4.3.2-9, shall neither exceed the maximum emission *basic limit*  $P_{\text{EM},B32,a}$ ,  $P_{\text{EM},B32,b}$  nor  $P_{\text{EM},B32,c}$  declared by the manufacturer.

**Table 6.6.4.3.2-9: Declared frequency band XXXII unwanted emission within 1452-1492 MHz**

Frequency offset of measurement filter centre frequency, $f_{\text{offset}}$	Declared emission <i>basic limit</i> [dBm]	Measurement bandwidth
5 MHz	$P_{\text{EM},B32,a}$	5 MHz
10 MHz	$P_{\text{EM},B32,b}$	5 MHz
$15 \text{ MHz} \leq f_{\text{offset}} \leq f_{\text{offset}_{\text{max}, B32}}$	$P_{\text{EM},B32,c}$	5 MHz
NOTE: $f_{\text{offset}_{\text{max}, B32}}$ denotes the frequency difference between the lower channel carrier frequency and 1454.5 MHz, and the frequency difference between the upper channel carrier frequency and 1489.5 MHz for the set channel position.		

NOTE: The regional requirement, included in CEPT ECC Decision (13)03 [25], is defined in terms of EIRP per antenna, which is dependent on both the BS emissions at the antenna connector and the deployment (including antenna gain and feeder loss). The *basic limit* defined above provides the characteristics of the base station needed to verify compliance with the regional requirement. The assessment of the EIRP level is described in annex H of 3GPP TS 36.104 [4].

In certain regions, the following *basic limit* may apply to *TAB connector* operating in Band XXXII within 1452-1492MHz for the protection of services in spectrum adjacent to the frequency range 1452-1492 MHz. The level of emissions, measured on centre frequencies  $F_{\text{filter}}$  with filter bandwidth according to table 6.6.4.3.2-10, shall neither exceed the maximum emission *basic limit*  $P_{\text{EM},B32,d}$  nor  $P_{\text{EM},B32,e}$  declared by the manufacturer. This requirement applies in the frequency range 1429-1518MHz even though part of the range falls in the spurious domain.

**Table 6.6.4.3-10: Frequency band XXXII declared emission outside 1452-1492 MHz**

Filter centre frequency, $F_{\text{filter}}$	Declared emission level [dBm]	Measurement bandwidth
$1429.5 \text{ MHz} \leq F_{\text{filter}} \leq 1448.5 \text{ MHz}$	$P_{\text{EM},\text{B32},\text{d}}$	1 MHz
$F_{\text{filter}} = 1450.5 \text{ MHz}$	$P_{\text{EM},\text{B32},\text{e}}$	3 MHz
$F_{\text{filter}} = 1493.5 \text{ MHz}$	$P_{\text{EM},\text{B32},\text{e}}$	3 MHz
$1495.5 \text{ MHz} \leq F_{\text{filter}} \leq 1517.5 \text{ MHz}$	$P_{\text{EM},\text{B32},\text{d}}$	1 MHz

NOTE: The regional requirement, included in CEPT ECC Decision (13)03 [25], is defined in terms of EIRP, which is dependent on both the BS emissions at the antenna connector and the deployment (including antenna gain and feeder loss). The *basic limit* defined above provides the characteristics of the base station needed to verify compliance with the regional requirement. The assessment of the EIRP level is described in annex H of 3GPP TS 36.104 [4].

Notes for the tables in this subclause:

NOTE 3: This frequency range ensures that the range of values of  $f_{\text{offset}}$  is continuous.

NOTE 4: As a general rule, the resolution bandwidth of the measuring equipment should be equal to the measurement bandwidth. However, to improve measurement accuracy, sensitivity and efficiency, the resolution bandwidth can be smaller than the measurement bandwidth. When the resolution bandwidth is smaller than the measurement bandwidth, the result should be integrated over the measurement bandwidth in order to obtain the equivalent noise bandwidth of the measurement bandwidth.

#### 6.6.4.3.3 Basic limits for single RAT UTRA TDD 1,28Mcps operation

The *basic limit* is specified in tables 6.6.4.3.3-1 to 6.6.4.3.3-3 for the appropriate  $P_{\text{Rated},\text{c},\text{sy}}$ , where:

The mask defined in table 6.6.4.3.3-1 to 6.6.4.3.3-3 may be mandatory in certain regions. In other regions this mask may not be applied.

For regions where this clause applies, the *basic limit* is for a *TAB connector* transmitting on a single RF carrier configured in accordance with the manufacturer's specification. Emissions shall use the *basic limits* specified in table 6.6.4.3.3-1 to 6.6.4.3.3-3 for the appropriate  $P_{\text{rated},\text{c},\text{cell}}$ , in the frequency range from  $\Delta f = 0.8 \text{ MHz}$  to  $\Delta f_{\text{max}}$  from the carrier frequency, where:

- $\Delta f$  is the separation between the carrier frequency and the nominal -3dB point of the measuring filter closest to the carrier frequency.
- $f_{\text{offset}}$  is the separation between the carrier frequency and the centre frequency of the measuring filter.-  
 $f_{\text{offset,max}}$  is either 4 MHz or the offset to the UTRA TDD Tx band edge as defined in subclause 4.6, whichever is the greater.
- $\Delta f_{\text{max}}$  is equal to  $f_{\text{offset,max}}$  minus half of the bandwidth of the measurement filter. Inside any *Inter RF bandwidth gaps* with  $W_{\text{gap}} < 8 \text{ MHz}$  for *multi-band TAB connector*, emissions shall not exceed the cumulative sum of the *basic limits* specified at the *Base Station RF bandwidth edges* on each side of *Inter RF bandwidth gap*. The *basic limit* for *Base Station RF bandwidth edge* is specified in tables 6.6.4.3.3-1 to 6.6.4.3.3-3 below, where in this case.
- $\Delta f$  equal to 0.8MHz plus the separation between the *Base Station RF bandwidth edge* frequency and the nominal -3dB point of the measuring filter closest to the *Base Station RF bandwidth edge*.
- $f_{\text{offset}}$  is equal to 0.8MHz plus the separation between the *Base Station RF bandwidth edge* frequency and the centre frequency of the measuring filter.
- $f_{\text{offset,max}}$  is either 4 MHz or the offset to the UTRA TDD Tx band edge as defined in subclause 4.6, whichever is the greater.
- $\Delta f_{\text{max}}$  is equal to  $f_{\text{offset,max}}$  minus half of the bandwidth of the measurement filter.

For a multi-carrier *TAB connector*, the definitions above apply to the lower edge of the carrier transmitted at the lowest carrier frequency and the upper edge of the carrier transmitted at the highest carrier frequency within a specified frequency.

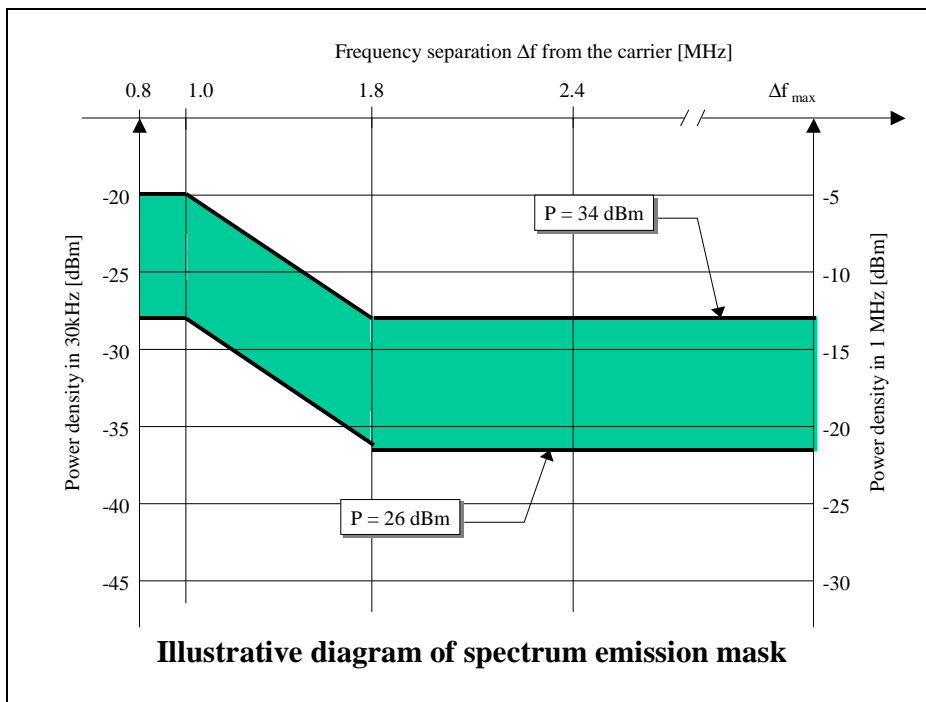

Figure 6.6.4.3.3-1

Table 6.6.4.3.3-1: **Basic Limits** for spectrum emission mask values,  $P_{\text{rated,c,cell}} - 10 \cdot \log_{10}(N_{\text{TXU,countedpercell}}) \geq 34 \text{ dBm}$  for 1,28 Mcps TDD

Frequency offset of measurement filter centre frequency, $f_{\text{offset}}$	Basic Limit	Measurement bandwidth
$0.8 \text{ MHz} \leq \Delta f < 1.0 \text{ MHz}$	-20 dBm	30 kHz
$1.0 \text{ MHz} \leq \Delta f < 1.8 \text{ MHz}$	$-20 \text{ dBm} - 10 \cdot \left( \frac{f_{\text{offset}}}{\text{MHz}} - 1,015 \right) \text{ dB}$	30 kHz
(NOTE)	-28 dBm	30 kHz
$1.8 \text{ MHz} \leq \Delta f \leq \Delta f_{\text{max}}$	-13 dBm	1 MHz
NOTE: For a multi-band TAB connector with Inter RF Bandwidth gap less than 8MHz, the basic limit within the Inter RF Bandwidth gap is calculated as a cumulative sum of emissions from the two adjacent carriers on each side of the Inter RF Bandwidth gap, where the contribution from the far-end RF Bandwidth shall be scaled according to the measurement bandwidth of the near-end RF Bandwidth.		

Table 6.6.4.3.3-2: **Basic Limits** for spectrum emission mask values,  $26 \text{ dBm} \leq P_{\text{rated,c,cell}} - 10 \cdot \log_{10}(N_{\text{TXU,countedpercell}}) < 34 \text{ dBm}$  for 1,28 Mcps TDD

Frequency offset of measurement filter centre frequency, $f_{\text{offset}}$	Basic Limit	Measurement bandwidth
$0.8 \text{ MHz} \leq \Delta f < 1.0 \text{ MHz}$	$P_{\text{rated,c,cell}} - 10 \cdot \log_{10}(N_{\text{TXU,countedpercell}}) - 54 \text{ dB}$	30 kHz
$1.0 \text{ MHz} \leq \Delta f < 1.8 \text{ MHz}$	$P_{\text{rated,c,cell}} - 10 \cdot \log_{10}(N_{\text{TXU,countedpercell}}) - 54 - 10 \cdot (f_{\text{offset}} - 1,015) \text{ dB}$	30 kHz
(NOTE)	$P_{\text{rated,c,cell}} - 10 \cdot \log_{10}(N_{\text{TXU,countedpercell}}) - 62 \text{ dB}$	30 kHz
$1.8 \text{ MHz} \leq \Delta f \leq \Delta f_{\text{max}}$	$P_{\text{rated,c,cell}} - 10 \cdot \log_{10}(N_{\text{TXU,countedpercell}}) - 47 \text{ dB}$	1 MHz
NOTE: For a multi-band TAB connector with Inter RF Bandwidth gap less than 8MHz, the basic limit within the Inter RF Bandwidth gap is calculated as a cumulative sum of emissions from the two adjacent carriers on each side of the Inter RF Bandwidth gap, where the contribution from the far-end RF Bandwidth shall be scaled according to the measurement bandwidth of the near-end RF Bandwidth.		

**Table 6.6.4.3.3-3: Basic Limits for spectrum emission mask values,  $P_{\text{rated,c,cell}} - 10 \cdot \log_{10}(N_{\text{TXU,countedpercell}}) < 26$  dBm for 1,28 Mcps TDD**

Frequency offset of measurement filter centre frequency, $f_{\text{offset}}$	Basic Limit	Measurement bandwidth
$0.8 \text{ MHz} \leq \Delta f < 1.0 \text{ MHz}$	-28 dBm	30 kHz
$1.0 \text{ MHz} \leq \Delta f < 1.8 \text{ MHz}$	$-28 \text{ dBm} - 10 \cdot \left( \frac{f_{\text{offset}}}{\text{MHz}} - 1,015 \right) \text{ dB}$	30 kHz
(NOTE)	-36 dBm	30 kHz
$1.8 \text{ MHz} \leq \Delta f \leq \Delta f_{\text{max}}$	-21 dBm	1 MHz
NOTE: For a multi-band TAB connector with Inter RF Bandwidth gap less than 8MHz, the basic limit within the Inter RF Bandwidth gap is calculated as a cumulative sum of emissions from the two adjacent carriers on each side of the Inter RF Bandwidth gap, where the contribution from the far-end RF Bandwidth shall be scaled according to the measurement bandwidth of the near-end RF Bandwidth.		

NOTE: This frequency range ensures that the range of values of  $f_{\text{offset}}$  is continuous.

#### 6.6.4.4 Minimum requirement for single RAT E-UTRA operation

There is no spectrum emission mask requirement for a single RAT E-UTRA AAS BS.

### 6.6.5 Operating band unwanted emission

#### 6.6.5.1 General

Unless otherwise stated, for E-UTRA single band and MSR the operating band unwanted emission limits are defined from  $\Delta f_{\text{OBUE}}$  below the lowest frequency of each supported *downlink operating band* to the lower *Base Station RF Bandwidth edge* located at  $F_{\text{BW RF,low}}$  and from the upper *Base Station RF Bandwidth edge* located at  $F_{\text{BW RF,high}}$  up to  $\Delta f_{\text{OBUE}}$  above the highest frequency of each supported *downlink operating band*. The values of  $\Delta f_{\text{OBUE}}$  are defined in table 6.6.1-1.

For AAS BS capable of operation in multiple operating bands, using *single band TAB connectors*, the single-band requirements apply to those connectors and the cumulative evaluation of the emission limit in the *Inter RF Bandwidth gap* is not applicable.

The requirements shall apply whatever the type of transmitter considered and for all transmission modes foreseen by the manufacturer's specification.

#### 6.6.5.2 Minimum requirement for MSR operation

##### 6.6.5.2.1 General

The MSR operating band unwanted emission *basic limits* are the same as those specified in 3GPP TS 37.104 [9], subclauses 6.6.2.1, 6.6.2.2 and 6.6.2.4.

The operating band unwanted emission requirements for an MSR AAS BS are that for each *TAB connector TX min cell group* and each applicable *basic limit* as specified in 3GPP TS 37.104 [5], the power summation of the emissions at the *TAB connectors* of the *TAB connector TX min cell group* shall not exceed an AAS BS limit specified as the *basic limit* +  $10 \log_{10}(N_{\text{TXU,countedpercell}})$ .

NOTE: Conformance to the AAS BS operating band unwanted emission requirement can be demonstrated by meeting at least one of the following criteria as determined by the manufacturer:

- 1) The sum of the emissions power measured on each *TAB connector* in the *TAB connector TX min cell group* shall be less than or equal to the AAS BS limit as defined in this subclause for the respective frequency span.

Or

- 2) The unwanted emissions power at each *TAB connector* shall be less than or equal to the AAS BS limit as defined in this subclause for the respective frequency span, scaled by  $-10\log_{10}(n)$ , where  $n$  is the number of *TAB connector* in the *TAB connector TX min cell group*.

#### 6.6.5.2.2 Basic limits for Band Categories 1 and 3

For a *TAB connector* operating in Band Category 1 or Band Category 3 the requirement applies outside the *Base Station RF Bandwidth edges*. In addition, for an AAS BS of Wide Area BS class operating in *non-contiguous spectrum*, it applies inside any *sub-block gap*. In addition, for an AAS BS of Wide Area BS class operating in multiple bands, the requirements apply inside any *Inter RF Bandwidth gap*.

For an AAS BS of Medium Range BS class operating in Band Category 1 the requirement applies outside the *Base Station RF Bandwidth edges*. In addition, for an AAS BS of Medium Range BS class operating in *non-contiguous spectrum*, it applies inside any *sub-block gap*. In addition, for an AAS BS of Medium Range BS class operating in multiple bands, the requirements apply inside any *Inter RF Bandwidth gap*.

For an AAS BS of Local Area BS class operating in Band Category 1 the requirement applies outside the *Base Station RF Bandwidth edges*. In addition, for an AAS BS of Local Area BS class operating in *non-contiguous spectrum*, it applies inside any *sub-block gap*. In addition, for an AAS BS Local Area BS class operating in multiple bands, the requirements apply inside any *Inter RF Bandwidth gap*.

Outside the *Base Station RF Bandwidth edges*, *basic limits* are specified in tables 6.6.5.2.2-1 to 6.6.5.2.2-4 below, where:

- $\Delta f$  is the separation between the *Base Station RF Bandwidth edge* frequency and the nominal -3 dB point of the measuring filter closest to the carrier frequency.
- $f_{\text{offset}}$  is the separation between the *Base Station RF Bandwidth edge* frequency and the centre of the measuring filter.
- $f_{\text{offset}_{\text{max}}}$  is the offset to the frequency  $\Delta f_{\text{OBUE}}$  outside the *downlink operating band*.
- $\Delta f_{\text{max}}$  is equal to  $f_{\text{offset}_{\text{max}}}$  minus half of the bandwidth of the measuring filter.

For a *multi-band TAB connector*, inside any *Inter RF Bandwidth gaps* with  $W_{\text{gap}} < 2 \times \Delta f_{\text{OBUE}}$  MHz, a combined *basic limit* shall be applied which is the cumulative sum of emissions shall not exceed the cumulative sum of the *basic limits* specified at the *Base Station RF Bandwidth edges* on each side of the *Inter-RF Bandwidth gap*. The *basic limit* for *Base Station RF Bandwidth edge* is specified in table 6.6.5.2.2-1 to 6.6.5.2.2-4 below, where in this case:

- $\Delta f$  is the separation between the *Base Station RF Bandwidth edge* frequency and the nominal -3 dB point of the measuring filter closest to the carrier frequency.
- $f_{\text{offset}}$  is the separation between the *Base Station RF Bandwidth edge* frequency and the centre of the measuring filter.
- $f_{\text{offset}_{\text{max}}}$  is equal to the inter *Base Station RF Bandwidth gap* minus half of the bandwidth of the measuring filter.
- $\Delta f_{\text{max}}$  is equal to  $f_{\text{offset}_{\text{max}}}$  minus half of the bandwidth of the measuring filter.

For a *multi-band TAB connector*, the operating band unwanted emission *basic limits* apply also in a supported operating band without any carriers transmitted, in the case where there are carriers transmitted in other operating band(s). In this case where there is no carrier transmitted in an operating band, the operating band unwanted emission limit, as defined in the tables of the present subclause for the largest frequency offset ( $\Delta f_{\text{max}}$ ), of a band where there is no carrier transmitted shall apply from 10 MHz below the lowest frequency, up to 10 MHz above the highest frequency of the supported downlink operating band without any carrier transmitted. And no cumulative *basic limits* are applied in the *inter-band gap* between a supported downlink band with carrier(s) transmitted and a supported downlink band without any carrier transmitted.

Inside any *sub-block gap* for a *TAB connector* operating in *non-contiguous spectrum*, a combined *basic limit* shall be applied which is the cumulative sum of the *basic limits* specified for the adjacent sub blocks on each side of the *sub-block gap*. The *basic limit* for each sub block is specified in tables 6.6.5.2.2-1 to 6.6.5.2.2-4 below, where in this case:

- $\Delta f$  is the separation between the sub block edge frequency and the nominal -3 dB point of the measuring filter closest to the sub block edge.
- $f_{\text{offset}}$  is the separation between the sub block edge frequency and the centre of the measuring filter.
- $f_{\text{offset}_{\text{max}}}$  is equal to the *sub-block gap* bandwidth minus half of the bandwidth of the measuring filter.
- $\Delta f_{\text{max}}$  is equal to  $f_{\text{offset}_{\text{max}}}$  minus half of the bandwidth of the measuring filter.

Applicability of Wide Area operating band unwanted emission requirements in tables 6.6.5.2.2-1, 6.6.5.2.2-1a and 6.6.5.2.2-1b is specified in table 6.6.2.1-0.

Note: Option 1 and Option 2 correspond to the Category B option 1/2 operating band unwanted emissions defined in the E-UTRA and NR specifications TS 36.104 [4] and TS 38.104 [27]. Option 2 also corresponds to the UTRA spectrum emission mask as defined in TS 25.104 [2].

**Table 6.6.5.2.2-0: Applicability of operating band unwanted emission requirements for BC1 and BC3 Wide Area BS**

NR band operation	UTRA supported	Applicable requirement table
None	Y/N	6.6.5.2.2-1 (Option 2)
In certain regions (NOTE 2), band 1, 7, 38, 65	N	6.6.5.2.2-1 (Option 2)
Any	Y	6.6.5.2.2-1 (Option 2)
Any below 1 GHz	N	6.6.5.2.2-1a (Option 1)
Any above 1 GHz except for certain regions (NOTE 2), band 1, 7, 38, 65	N	6.6.5.2.2-1b (Option 1)

NOTE 1: Void.  
 NOTE 2: Applicable only for operation in regions where Category B limits as defined in ITU-R Recommendation SM.329 [14] are used for which category B option 2 operating band unwanted emissions requirements as defined in TS 36.104 [8] and TS 38.104 [27] are applied.

**Table 6.6.5.2.2-1: WA BS OBUE in BC1 and BC3 bands - option 2**

Frequency offset of measurement filter -3dB point, $\Delta f$	Frequency offset of measurement filter centre frequency, $f_{\text{offset}}$	Basic Limit (NOTE 1, 2)	Measurement bandwidth (NOTE 4)
$0 \text{ MHz} \leq \Delta f < 0.2 \text{ MHz}$	$0.015 \text{ MHz} \leq f_{\text{offset}} < 0.215 \text{ MHz}$	-14 dBm	30 kHz
$0.2 \text{ MHz} \leq \Delta f < 1 \text{ MHz}$	$0.215 \text{ MHz} \leq f_{\text{offset}} < 1.015 \text{ MHz}$	$-14 \text{ dBm} - 15 \cdot \left( \frac{f_{\text{offset}}}{\text{MHz}} - 0.215 \right) \text{ dB}$  (Note 6)	30 kHz
(NOTE 3)	$1.015 \text{ MHz} \leq f_{\text{offset}} < 1.5 \text{ MHz}$	-26 dBm (Note 6)	30 kHz
$1 \text{ MHz} \leq \Delta f \leq \min(\Delta f_{\text{max}}, 10 \text{ MHz})$	$1.5 \text{ MHz} \leq f_{\text{offset}} < \min(f_{\text{offset}_{\text{max}}}, 10.5 \text{ MHz})$	-13 dBm (Note 6)	1 MHz
$10 \text{ MHz} \leq \Delta f \leq \Delta f_{\text{max}}$	$10.5 \text{ MHz} \leq f_{\text{offset}} < f_{\text{offset}_{\text{max}}}$	-15 dBm (NOTE 5, 6)	1 MHz

NOTE 1: For MSR *TAB connector* supporting *non-contiguous spectrum* operation within any operating band the *basic limit* within *sub-block gaps* is calculated as a cumulative sum of contributions from adjacent sub-blocks on each side of the *sub-block gap*, where the contribution from the far-end sub-block shall be scaled according to the measurement bandwidth of the near-end sub-block. Exception is  $\Delta f \geq 10 \text{ MHz}$  from both adjacent sub-blocks on each side of the *sub-block gap*, where the *basic limit* within *sub-block gaps* shall be -15dBm/MHz (for MSR *multi-band TAB connector*, either this limit or -16dBm/100kHz with correspondingly adjusted  $f_{\text{offset}}$  shall apply for this frequency offset range for operating bands < 1 GHz).

NOTE 2: For MSR *multi-band TAB connector* with *Inter RF Bandwidth gap* <  $2 \times \Delta f_{\text{OBUE}}$  the *basic limit* within the *Inter RF Bandwidth gaps* is calculated as a cumulative sum of contributions from adjacent sub-blocks or *Base Station RF Bandwidth* on each side of the *Inter RF Bandwidth gap*, where the contribution from the far-end sub-block or RF Bandwidth shall be scaled according to the measurement bandwidth of the near-end sub-block or RF Bandwidth.

NOTE 6: For MSR *multi-band TAB connector*, either this limit or -16dBm/100kHz with correspondingly adjusted  $f_{\text{offset}}$  shall apply for this frequency offset range for operating bands < 1 GHz.

Table 6.6.5.2.2-1a: WA BS OBUE in BC1 and BC3 bands ≤ 1 GHz - option 1

Frequency offset of measurement filter -3dB point, $\Delta f$	Frequency offset of measurement filter centre frequency, $f_{\text{offset}}$	Basic Limit (Note 1, 2)	Measurement bandwidth (Note 4)
$0 \text{ MHz} \leq \Delta f < 5 \text{ MHz}$	$0.05 \text{ MHz} \leq f_{\text{offset}} < 5.05 \text{ MHz}$	$-7 \text{ dBm} - \frac{7}{5} \cdot \left( \frac{f_{\text{offset}}}{\text{MHz}} - 0.05 \right) \text{ dB}$	100 kHz
$5 \text{ MHz} \leq \Delta f < \min(10 \text{ MHz}, \Delta f_{\text{max}})$	$5.05 \text{ MHz} \leq f_{\text{offset}} < \min(10.05 \text{ MHz}, f_{\text{offset}_{\text{max}}})$	-14 dBm	100 kHz
$10 \text{ MHz} \leq \Delta f \leq \Delta f_{\text{max}}$	$10.05 \text{ MHz} \leq f_{\text{offset}} < f_{\text{offset}_{\text{max}}}$	-16 dBm (Note 5)	100 kHz
NOTE 1: For MSR <i>TAB connector</i> supporting non-contiguous spectrum operation within any operating band, the <i>basic limit</i> within <i>sub-block gaps</i> is calculated as a cumulative sum of contributions from adjacent sub blocks on each side of the <i>sub block gap</i> . Exception is $\Delta f \geq 10 \text{ MHz}$ from both adjacent sub blocks on each side of the sub-block gap, where the <i>basic limit</i> within sub-block gaps shall be -16dBm/100kHz.			
NOTE 2: For MSR <i>multi band TAB connector</i> with <i>Inter RF Bandwidth gap</i> $< 2 \times \Delta f_{\text{OBUE}}$ the <i>basic limit</i> within the <i>Inter RF Bandwidth gaps</i> is calculated as a cumulative sum of contributions from adjacent sub-blocks or Base station <i>RF Bandwidth</i> on each side of the <i>Inter RF Bandwidth gap</i> .			

Table 6.6.5.2.2-1b: WA BS OBUE in BC1 and BC3 bands &gt; 1 GHz - option 1

Frequency offset of measurement filter -3dB point, $\Delta f$	Frequency offset of measurement filter centre frequency, $f_{\text{offset}}$	Basic Limit (Note 1, 2)	Measurement bandwidth (Note 4)
$0 \text{ MHz} \leq \Delta f < 5 \text{ MHz}$	$0.05 \text{ MHz} \leq f_{\text{offset}} < 5.05 \text{ MHz}$	$-7 \text{ dBm} - \frac{7}{5} \cdot \left( \frac{f_{\text{offset}}}{\text{MHz}} - 0.05 \right) \text{ dB}$	100 kHz
$5 \text{ MHz} \leq \Delta f < \min(10 \text{ MHz}, \Delta f_{\text{max}})$	$5.05 \text{ MHz} \leq f_{\text{offset}} < \min(10.05 \text{ MHz}, f_{\text{offset}_{\text{max}}})$	-14 dBm	100 kHz
$10 \text{ MHz} \leq \Delta f \leq \Delta f_{\text{max}}$	$10.5 \text{ MHz} \leq f_{\text{offset}} < f_{\text{offset}_{\text{max}}}$	-15 dBm (Note 5)	1MHz
NOTE 1: For MSR <i>TAB connector</i> supporting non-contiguous spectrum operation within any operating band, the <i>basic limit</i> within sub-block gaps is calculated as a cumulative sum of contributions from adjacent sub blocks on each side of the <i>sub block gap</i> , where the contribution from the far-end sub-block shall be scaled according to the measurement bandwidth of the near-end sub-block. Exception is $\Delta f \geq 10 \text{ MHz}$ from both adjacent sub blocks on each side of the <i>sub-block gap</i> , where the <i>basic limit</i> within sub-block gaps shall be -15dBm/1MHz.			
NOTE 2: For MSR <i>multi band TAB connector</i> with <i>Inter RF Bandwidth gap</i> $< 2 \times \Delta f_{\text{OBUE}}$ the <i>basic limit</i> within the <i>Inter RF Bandwidth gaps</i> is calculated as a cumulative sum of contributions from adjacent sub-blocks or <i>RF Bandwidth</i> on each side of the <i>Inter RF Bandwidth gap</i> , where the contribution from the far-end sub-block or <i>RF Bandwidth</i> shall be scaled according to the measurement bandwidth of the near-end sub-block or <i>RF Bandwidth</i> .			

**Table 6.6.5.2.2-2: MR BS OBUE in BC1 bands applicable for: BS with maximum output power  $31 < P_{\text{rated,c,cell}} - 10 \cdot \log_{10}(N_{\text{TXU,countedpercell}}) \leq 38$  dBm and not supporting NR; or BS with maximum output power  $31 < P_{\text{rated,c,cell}} - 10 \cdot \log_{10}(N_{\text{TXU,countedpercell}}) \leq 38$  dBm supporting NR, and supporting UTRA**

Frequency offset of measurement filter -3dB point, $\Delta f$	Frequency offset of measurement filter centre frequency, $f_{\text{offset}}$	Basic Limit (NOTE 1, 2)	Measurement bandwidth (NOTE 4)
$0 \text{ MHz} \leq \Delta f < 0.6 \text{ MHz}$	$0.015 \text{ MHz} \leq f_{\text{offset}} < 0.615 \text{ MHz}$	$P_{\text{rated,c,cell}} - 10 \cdot \log_{10}(N_{\text{TXU,countedpercell}}) - 58 \text{ dB} - \frac{5}{3} \left( \frac{f_{\text{offset}}}{\text{MHz}} - 0.015 \right) \text{ dB}$	30 kHz
$0.6 \text{ MHz} \leq \Delta f < 1 \text{ MHz}$	$0.615 \text{ MHz} \leq f_{\text{offset}} < 1.015 \text{ MHz}$	$P_{\text{rated,c,cell}} - 10 \cdot \log_{10}(N_{\text{TXU,countedpercell}}) - 53 \text{ dB} - 15 \left( \frac{f_{\text{offset}}}{\text{MHz}} - 0.215 \right) \text{ dB}$	30 kHz
(NOTE 3)	$1.015 \text{ MHz} \leq f_{\text{offset}} < 1.5 \text{ MHz}$	$P_{\text{rated,c,cell}} - 10 \cdot \log_{10}(N_{\text{TXU,countedpercell}}) - 65 \text{ dB}$	30 kHz
$1 \text{ MHz} \leq \Delta f \leq 2.6 \text{ MHz}$	$1.5 \text{ MHz} \leq f_{\text{offset}} < 3.1 \text{ MHz}$	$P_{\text{rated,c,cell}} - 10 \cdot \log_{10}(N_{\text{TXU,countedpercell}}) - 52 \text{ dB}$	1 MHz
$2.6 \text{ MHz} \leq \Delta f \leq 5 \text{ MHz}$	$3.1 \text{ MHz} \leq f_{\text{offset}} < 5.5 \text{ MHz}$	$\min(P_{\text{rated,c,cell}} - 10 \cdot \log_{10}(N_{\text{TXU,countedpercell}}) - 52 \text{ dB}, -15 \text{ dBm})$	1 MHz
$5 \text{ MHz} \leq \Delta f \leq \Delta f_{\text{max}}$	$5.5 \text{ MHz} \leq f_{\text{offset}} < f_{\text{offsetmax}}$	$P_{\text{rated,c,cell}} - 10 \cdot \log_{10}(N_{\text{TXU,countedpercell}}) - 56 \text{ dB}$	1 MHz
<p>NOTE 1: For MSR <i>TAB connector</i> supporting <i>non-contiguous spectrum</i> operation within any operating band the <i>basic limit</i> within <i>sub-block gaps</i> is calculated as a cumulative sum of contributions from adjacent sub blocks on each side of the <i>sub-block gap</i>, where the contribution from the far-end sub-block shall be scaled according to the measurement bandwidth of the near-end sub-block. Exception is <math>\Delta f \geq 10 \text{ MHz}</math> from both adjacent sub-blocks on each side of the <i>sub-block gap</i>, where the <i>basic limit</i> within <i>sub-block gaps</i> shall be <math>(P_{\text{rated,c,cell}} - 10 \cdot \log_{10}(N_{\text{TXU,countedpercell}}) - 56 \text{ dB}) / \text{MHz}</math>.</p> <p>NOTE 2: For MSR multi-band <i>TAB connector</i> with <i>Inter RF Bandwidth gap</i> <math>&lt; 2 \times \Delta f_{\text{OBUE}}</math> the <i>basic limit</i> within the <i>Inter RF Bandwidth gaps</i> is calculated as a cumulative sum of contributions from adjacent sub-blocks or <i>Base Station RF Bandwidth</i> on each side of the <i>Inter RF Bandwidth gap</i>, where the contribution from the far-end sub-block or <i>Base Station RF Bandwidth</i> shall be scaled according to the measurement bandwidth of the near-end sub-block or <i>Base Station RF Bandwidth</i>.</p>			

**Table 6.6.5.2.2-2a: MR BS OBUE in BC1 bands applicable for: BS with maximum output power  $31 < P_{\text{rated,c,cell}} - 10 \cdot \log_{10}(N_{\text{TXU,countedpercell}}) \leq 38$  dBm, supporting NR and not supporting UTRA**

Frequency offset of measurement filter -3dB point, $\Delta f$	Frequency offset of measurement filter centre frequency, $f_{\text{offset}}$	Basic Limit (Note 1, 2)	Measurement bandwidth (Note 4)
$0 \text{ MHz} \leq \Delta f < 5 \text{ MHz}$	$0.05 \text{ MHz} \leq f_{\text{offset}} < 5.05 \text{ MHz}$	$P_{\text{rated,c,cell}} - 10 \cdot \log_{10}(N_{\text{TXU,countedpercell}}) - 53 \text{ dB} - (7/5) \cdot (f_{\text{offset}} / \text{MHz} - 0.05) \text{ dB}$	100 kHz
$5 \text{ MHz} \leq \Delta f < \min(10 \text{ MHz}, \Delta f_{\text{max}})$	$5.05 \text{ MHz} \leq f_{\text{offset}} < \min(10.05 \text{ MHz}, f_{\text{offsetmax}})$	$P_{\text{rated,c,cell}} - 10 \cdot \log_{10}(N_{\text{TXU,countedpercell}}) - 60 \text{ dB}$	100 kHz
$10 \text{ MHz} \leq \Delta f \leq \Delta f_{\text{max}}$	$10.05 \text{ MHz} \leq f_{\text{offset}} < f_{\text{offsetmax}}$	$\text{Min}(P_{\text{rated,c,cell}} - 10 \cdot \log_{10}(N_{\text{TXU,countedpercell}}) - 60 \text{ dB}, -25 \text{ dBm})$ (Note 5)	100 kHz
<p>NOTE 1: For MSR <i>TAB connector</i> supporting <i>non-contiguous spectrum</i> operation within any operating band the <i>basic limit</i> within <i>sub-block gaps</i> is calculated as a cumulative sum of contributions from adjacent sub blocks on each side of the <i>sub block gap</i>. Exception is <math>\Delta f \geq 10 \text{ MHz}</math> from both adjacent sub blocks on each side of the <i>sub-block gap</i>, where the <i>basic limit</i> within <i>sub-block gaps</i> shall be <math>\text{Min}(P_{\text{rated,c,cell}} - 10 \cdot \log_{10}(N_{\text{TXU,countedpercell}}) - 60 \text{ dB}, -25 \text{ dBm}) / 100 \text{ kHz}</math>.</p> <p>NOTE 2: For MSR <i>multi band TAB connector</i> with <i>Inter RF Bandwidth gap</i> <math>&lt; 2 \times \Delta f_{\text{OBUE}}</math> the <i>basic limit</i> within the <i>Inter RF Bandwidth gaps</i> is calculated as a cumulative sum of contributions from adjacent sub-blocks or <i>RF Bandwidth</i> on each side of the <i>Inter RF Bandwidth gap</i>.</p>			

**Table 6.6.5.2.2-3: MR BS OBUE in BC1 bands applicable for: BS with maximum output power  $P_{\text{rated,c,cell}} \cdot 10 \cdot \log_{10}(N_{\text{TXU,countedpercell}}) \leq 31$  dBm and not supporting NR; or BS with maximum output power  $P_{\text{rated,c,cell}} \cdot 10 \cdot \log_{10}(N_{\text{TXU,countedpercell}}) \leq 31$  dBm supporting NR, and supporting UTRA**

Frequency offset of measurement filter -3dB point, $\Delta f$	Frequency offset of measurement filter centre frequency, $f_{\text{offset}}$	Basic Limit (NOTE 1, 2)	Measurement bandwidth (NOTE 4)
$0 \text{ MHz} \leq \Delta f < 0.6 \text{ MHz}$	$0.015 \text{ MHz} \leq f_{\text{offset}} < 0.615 \text{ MHz}$	$-27 \text{ dBm} - \frac{5}{3} \left( \frac{f_{\text{offset}}}{\text{MHz}} - 0.015 \right) \text{ dB}$	30 kHz
$0.6 \text{ MHz} \leq \Delta f < 1 \text{ MHz}$	$0.615 \text{ MHz} \leq f_{\text{offset}} < 1.015 \text{ MHz}$	$-22 \text{ dBm} - 15 \cdot \left( \frac{f_{\text{offset}}}{\text{MHz}} - 0.215 \right) \text{ dB}$	30 kHz
(NOTE 3)	$1.015 \text{ MHz} \leq f_{\text{offset}} < 1.5 \text{ MHz}$	-34 dBm	30 kHz
$1 \text{ MHz} \leq \Delta f \leq 5 \text{ MHz}$	$1.5 \text{ MHz} \leq f_{\text{offset}} < 5.5 \text{ MHz}$	-21 dBm	1 MHz
$5 \text{ MHz} \leq \Delta f \leq \Delta f_{\text{max}}$	$5.5 \text{ MHz} \leq f_{\text{offset}} < f_{\text{offset}_{\text{max}}}$	-25 dBm	1 MHz
<p>NOTE 1: For MSR <i>TAB connector</i> supporting <i>non-contiguous spectrum</i> operation within any operating band the <i>basic limit</i> within <i>sub-block gaps</i> is calculated as a cumulative sum of contributions from adjacent sub blocks on each side of the <i>sub-block gap</i>, where the contribution from the far-end sub-block shall be scaled according to the measurement bandwidth of the near-end sub-block. Exception is <math>\Delta f \geq 10 \text{ MHz}</math> from both adjacent sub-blocks on each side of the <i>sub-block gap</i>, where the <i>basic limit</i> within <i>sub-block gaps</i> shall be -25 dBm/MHz.</p> <p>NOTE 2: For MSR <i>multi-band TAB connector</i> with <i>Inter RF Bandwidth gap</i> <math>&lt; 2 \times \Delta f_{\text{OBUE}}</math> the <i>basic limit</i> within the <i>Inter RF Bandwidth gaps</i> is calculated as a cumulative sum of contributions from adjacent sub-blocks or <i>Base Station RF Bandwidth</i> on each side of the <i>Inter RF Bandwidth gap</i>, where the contribution from the far-end sub-block or <i>Base Station RF Bandwidth</i> shall be scaled according to the measurement bandwidth of the near-end sub-block or <i>Base Station RF Bandwidth</i>.</p>			

**Table 6.6.5.2.2-3a: MR BS OBUE in BC1 bands applicable for: BS with maximum output power  $P_{\text{rated,c,cell}} \cdot 10 \cdot \log_{10}(N_{\text{TXU,countedpercell}}) \leq 31$  dBm, supporting NR and not supporting UTRA**

Frequency offset of measurement filter -3dB point, $\Delta f$	Frequency offset of measurement filter centre frequency, $f_{\text{offset}}$	Basic limit (Note 1, 2)	Measurement bandwidth (Note 4)
$0 \text{ MHz} \leq \Delta f < 5 \text{ MHz}$	$0.05 \text{ MHz} \leq f_{\text{offset}} < 5.05 \text{ MHz}$	$-22 \text{ dBm} - \frac{7}{5} \left( \frac{f_{\text{offset}}}{\text{MHz}} - 0.05 \right) \text{ dB}$	100 kHz
$5 \text{ MHz} \leq \Delta f < \min(10 \text{ MHz}, \Delta f_{\text{max}})$	$5.05 \text{ MHz} \leq f_{\text{offset}} < \min(10.05 \text{ MHz}, f_{\text{offset}_{\text{max}}})$	-29 dBm	100 kHz
$10 \text{ MHz} \leq \Delta f \leq \Delta f_{\text{max}}$	$10.05 \text{ MHz} \leq f_{\text{offset}} < f_{\text{offset}_{\text{max}}}$	-29 dBm (Note 5)	100 kHz
<p>NOTE 1: For MSR <i>TAB connector</i> supporting <i>non-contiguous spectrum</i> operation within any operating band the <i>basic limit</i> within <i>sub-block gaps</i> is calculated as a cumulative sum of contributions from adjacent sub blocks on each side of the <i>sub-block gap</i>. Exception is <math>\Delta f \geq 10 \text{ MHz}</math> from both adjacent sub blocks on each side of the <i>sub-block gap</i>, where the <i>basic limit</i> within <i>sub-block gaps</i> shall be -29dBm/100kHz.</p> <p>NOTE 2: For MSR <i>multi band TAB connector</i> with <i>Inter RF Bandwidth gap</i> <math>&lt; 2 \times \Delta f_{\text{OBUE}}</math> the <i>basic limit</i> within the <i>Inter RF Bandwidth gaps</i> is calculated as a cumulative sum of contributions from adjacent sub-blocks or <i>RF Bandwidth</i> on each side of the <i>Inter RF Bandwidth gap</i>.</p>			

Table 6.6.5.2.2-4: LA BS OBUE in BC1 bands

Frequency offset of measurement filter -3dB point, $\Delta f$	Frequency offset of measurement filter centre frequency, $f_{\text{offset}}$	Basic Limit (Note 1, 2)	Measurement bandwidth (NOTE 4)
$0 \text{ MHz} \leq \Delta f < 5 \text{ MHz}$	$0.05 \text{ MHz} \leq f_{\text{offset}} < 5.05 \text{ MHz}$	$-30 \text{ dBm} - \frac{7}{5} \left( \frac{f_{\text{offset}}}{\text{MHz}} - 0.05 \right) \text{ dB}$	100 kHz
$5 \text{ MHz} \leq \Delta f < \min(10 \text{ MHz}, \Delta f_{\text{max}})$	$5.05 \text{ MHz} \leq f_{\text{offset}} < \min(10.05 \text{ MHz}, f_{\text{offset}_{\text{max}}})$	-37 dBm	100 kHz
$10 \text{ MHz} \leq \Delta f \leq \Delta f_{\text{max}}$	$10.05 \text{ MHz} \leq f_{\text{offset}} < f_{\text{offset}_{\text{max}}}$	-37 dBm (NOTE 5)	100 kHz
NOTE 1: For MSR TAB connector supporting <i>non-contiguous spectrum</i> operation within any operating band the <i>basic limit</i> within <i>sub-block gaps</i> is calculated as a cumulative sum of contributions from adjacent sub blocks on each side of the <i>sub-block gap</i> . Exception is $\Delta f \geq 10 \text{ MHz}$ from both adjacent sub blocks on each side of the <i>sub-block gap</i> , where the <i>basic limit</i> within <i>sub-block gaps</i> shall be -37dBm/100 kHz.			
NOTE 2: For MSR multi-band TAB connector with <i>Inter RF Bandwidth gap</i> $< 2 \times \Delta f_{\text{OBUE}}$ the <i>basic limit</i> within the <i>Inter RF Bandwidth gaps</i> is calculated as a cumulative sum of contributions from adjacent sub-blocks or <i>Base Station RF Bandwidth</i> on each side of the <i>Inter RF Bandwidth gap</i> .			

NOTE 3: This frequency range ensures that the range of values of  $f_{\text{offset}}$  is continuous.

NOTE 4: As a general rule for the requirements in the present subclause, the resolution bandwidth of the measuring equipment should be equal to the measurement bandwidth. However, to improve measurement accuracy, sensitivity and efficiency, the resolution bandwidth may be smaller than the measurement bandwidth. When the resolution bandwidth is smaller than the measurement bandwidth, the result should be integrated over the measurement bandwidth in order to obtain the equivalent noise bandwidth of the measurement bandwidth.

NOTE 5: The requirement is not applicable when  $\Delta f_{\text{max}} < 10 \text{ MHz}$ .

### 6.6.5.2.3 Basic limit for Band Category 2

For a TAB connector operating in Band Category 2 the requirement applies outside the *Base Station RF Bandwidth edges*. In addition, for a TAB connector operating in *non-contiguous spectrum*, it applies inside any *sub-block gap*.

Outside the *Base Station RF Bandwidth edges*, *basic limits* are specified in tables 6.6.5.2.3-1 to 6.6.5.2.3-8 below, where:

- $\Delta f$  is the separation between the *Base Station RF Bandwidth edge* frequency and the nominal -3dB point of the measuring filter closest to the carrier frequency.
- $f_{\text{offset}}$  is the separation between the *Base Station RF Bandwidth edge* frequency and the centre of the measuring filter.
- $f_{\text{offset}_{\text{max}}}$  is the offset to the frequency  $\Delta f_{\text{OBUE}}$  outside the *downlink operating band*.
- $\Delta f_{\text{max}}$  is equal to  $f_{\text{offset}_{\text{max}}}$  minus half of the bandwidth of the measuring filter.

For a *multi-band TAB connector*, inside any *Inter-RF Bandwidth gaps* with  $W_{\text{gap}} < 2 \times \Delta f_{\text{OBUE}}$  MHz, a combined *basic limit* shall be applied which is the cumulative sum of the *basic limits* specified at the *Base Station RF Bandwidth edges* on each side of the *Inter-RF Bandwidth gap*. The *basic limit* for *Base Station RF Bandwidth edge* is specified in table 6.6.5.2.3-1 to 6.6.5.2.3-8 below, where in this case:

- $\Delta f$  is the separation between the *Base Station RF Bandwidth edge* frequency and the nominal -3 dB point of the measuring filter closest to the carrier frequency.
- $f_{\text{offset}}$  is the separation between the *Base Station RF Bandwidth edge* frequency and the centre of the measuring filter.
- $f_{\text{offset}_{\text{max}}}$  is equal to the *Inter RF Bandwidth gap* minus half of the bandwidth of the measuring filter.
- $\Delta f_{\text{max}}$  is equal to  $f_{\text{offset}_{\text{max}}}$  minus half of the bandwidth of the measuring filter.

For a *multi-band TAB connector* where multiple bands are mapped on the same antenna connector and where there is no carrier transmitted in an operating band, the operating band unwanted emission limit, as defined in the tables of the

present subclause for the largest frequency offset ( $\Delta f_{\max}$ ), of a band where there is no carrier transmitted shall apply from 10 MHz below the lowest frequency, up to 10 MHz above the highest frequency of the supported downlink operating band without any carrier transmitted. And no cumulative *basic limits* are applied in the *inter-band gap* between a supported downlink band with carrier(s) transmitted and a supported downlink band without any carrier transmitted.

Inside any *sub-block gap* for a *TAB connector* operating in *non-contiguous spectrum*, a combined *basic limit* shall be applied which is the cumulative sum of the *basic limit* specified for the adjacent sub blocks on each side of the *sub-block gap*. The *basic limit* for each sub block is specified in tables 6.6.5.2.3-1 to 6.6.5.2.3-8 below, where in this case:

- $\Delta f$  is the separation between the sub block edge frequency and the nominal -3 dB point of the measuring filter closest to the sub block edge.
- $f_{\text{offset}}$  is the separation between the sub block edge frequency and the centre of the measuring filter.
- $f_{\text{offset}_{\max}}$  is equal to the *sub-block gap* bandwidth minus half of the bandwidth of the measuring filter.
- $\Delta f_{\max}$  is equal to  $f_{\text{offset}_{\max}}$  minus half of the bandwidth of the measuring filter.

Applicability of Wide Area operating band unwanted emission requirements in Tables 6.6.5.2.31, 6.6.5.2.3-1a and 6.6.5.2.3-1b is specified in table 6.6.5.2.3-0.

Note: Option 1 and option 2 correspond to the Category B option 1/2 operating band unwanted emissions defined in the E-UTRA and NR specifications TS 36.104 [4] and TS 38.104 [27]. Option 2 also corresponds to the UTRA spectrum emission mask as defined in TS 25.104 [2].

**Table 6.6.5.2.3-0: Applicability of operating band unwanted emission requirements for BC2 Wide Area BS**

NR band operation	UTRA supported	Applicable requirement table
None	Y/N	6.6.5.2.3-1 (option 2)
In certain regions (NOTE 2), bands 3, 8	N	6.6.5.2.3-1 (option 2)
Any	Y	6.6.5.2.3-1 (option 2)
Any below 1 GHz except for certain regions (NOTE 2), band 8	N	6.6.5.2.3-1a (option 1)
Any above 1 GHz except for certain regions (NOTE 2), band 3	N	6.6.5.2.3-1b (option 1)
NOTE 1: Void.		
NOTE 2: Applicable only for operation in regions where Category B limits as defined in ITU-R Recommendation SM.329 [14] are used for which category B option 2 operating band unwanted emissions requirements as defined in TS 36.104 [8] and TS 38.104 [27] are applied.		

Table 6.6.5.2.3-1: WA BS OBUE in BC2 bands – option 2

Frequency offset of measurement filter -3dB point, $\Delta f$	Frequency offset of measurement filter centre frequency, $f_{\text{offset}}$	Basic Limit (NOTE 2, 3)	Measurement bandwidth (NOTE 10)
$0 \text{ MHz} \leq \Delta f < 0.2 \text{ MHz}$ (NOTE 1)	$0.015 \text{ MHz} \leq f_{\text{offset}} < 0.215 \text{ MHz}$	-14 dBm	30 kHz
$0.2 \text{ MHz} \leq \Delta f < 1 \text{ MHz}$	$0.215 \text{ MHz} \leq f_{\text{offset}} < 1.015 \text{ MHz}$	$-14 \text{ dBm} - 15 \cdot \left( \frac{f_{\text{offset}}}{\text{MHz}} - 0.215 \right) \text{ dB}$  (Note 13)	30 kHz
(NOTE 9)	$1.015 \text{ MHz} \leq f_{\text{offset}} < 1.5 \text{ MHz}$	-26 dBm (Note 13)	30 kHz
$1 \text{ MHz} \leq \Delta f \leq \min(\Delta f_{\text{max}}, 10 \text{ MHz})$	$1.5 \text{ MHz} \leq f_{\text{offset}} < \min(f_{\text{offset}_{\text{max}}}, 10.5 \text{ MHz})$	-13 dBm (Note 13)	1 MHz
$10 \text{ MHz} \leq \Delta f \leq \Delta f_{\text{max}}$	$10.5 \text{ MHz} \leq f_{\text{offset}} < f_{\text{offset}_{\text{max}}}$	-15 dBm (NOTE 11, 13)	1 MHz
<p>NOTE 1: For operation with an E-UTRA 1.4 or 3 MHz carrier adjacent to the <i>Base Station RF Bandwidth edge</i> or the sub-block edge, the limits in table 6.6.5.2.3-2 apply for <math>0 \text{ MHz} \leq \Delta f &lt; 0.15 \text{ MHz}</math>.</p> <p>NOTE 2: For MSR <i>TAB connector</i> supporting <i>non-contiguous spectrum</i> operation within any operating band the <i>basic limit</i> within <i>sub-block gaps</i> is calculated as a cumulative sum of contributions from adjacent sub-blocks on each side of the <i>sub-block gap</i>, where the contribution from the far-end sub-block shall be scaled according to the measurement bandwidth of the near-end sub-block. Exception is <math>\Delta f \geq 10 \text{ MHz}</math> from both adjacent sub-blocks on each side of the <i>sub-block gap</i>, where the <i>basic limit</i> within <i>sub-block gaps</i> shall be -15dBm/MHz (for MSR <i>multi-band TAB connector</i>, either this limit or -16dBm/100kHz with correspondingly adjusted <math>f_{\text{offset}}</math> shall apply for this frequency offset range for operating bands &lt; 1 GHz).</p> <p>NOTE 3: For a MSR <i>multi-band TAB connector</i> with <i>Inter RF Bandwidth gap</i> &lt; <math>2 \times \Delta f_{\text{OBUE}}</math> operation the <i>basic limit</i> within the <i>Inter RF Bandwidth gaps</i> is calculated as a cumulative sum of contributions from adjacent sub-blocks or <i>Base Station RF Bandwidth</i> on each side of the <i>Inter RF Bandwidth gap</i>, where the contribution from the far-end sub-block or <i>Base Station RF Bandwidth</i> shall be scaled according to the measurement bandwidth of the near-end sub-block or <i>Base Station RF Bandwidth</i>.</p> <p>NOTE 13: For MSR <i>multi-band TAB connector</i>, either this limit or -16dBm/100kHz with correspondingly adjusted <math>f_{\text{offset}}</math> shall apply for this frequency offset range for operating bands &lt; 1 GHz.</p>			

Table 6.6.5.2.3-1a: WA BS OBUE in BC2 bands  $\leq 1 \text{ GHz}$  – option 1

Frequency offset of measurement filter -3dB point, $\Delta f$	Frequency offset of measurement filter centre frequency, $f_{\text{offset}}$	Basic limit (Note 1, 2)	Measurement bandwidth (Note 10)
$0 \text{ MHz} \leq \Delta f < 5 \text{ MHz}$	$0.05 \text{ MHz} \leq f_{\text{offset}} < 5.05 \text{ MHz}$	$-7 \text{ dBm} - \frac{7}{5} \cdot \left( \frac{f_{\text{offset}}}{\text{MHz}} - 0.05 \right) \text{ dB}$	100 kHz
$5 \text{ MHz} \leq \Delta f < \min(10 \text{ MHz}, \Delta f_{\text{max}})$	$5.05 \text{ MHz} \leq f_{\text{offset}} < \min(10.05 \text{ MHz}, f_{\text{offset}_{\text{max}}})$	-14 dBm	100 kHz
$10 \text{ MHz} \leq \Delta f \leq \Delta f_{\text{max}}$	$10.05 \text{ MHz} \leq f_{\text{offset}} < f_{\text{offset}_{\text{max}}}$	-16 dBm (Note 11)	100 kHz
<p>NOTE 1: For MSR <i>TAB connector</i> supporting non-contiguous spectrum operation within any operating band, the <i>basic limit</i> within <i>sub-block gaps</i> is calculated as a cumulative sum of contributions from adjacent sub blocks on each side of the sub block gap. Exception is <math>\Delta f \geq 10 \text{ MHz}</math> from both adjacent sub blocks on each side of the <i>sub-block gap</i>, where the <i>basic limit</i> within sub-block gaps shall be -16dBm/100kHz.</p> <p>NOTE 2: For MSR <i>multi band TAB connector</i> with <i>Inter RF Bandwidth gap</i> &lt; <math>2 \times \Delta f_{\text{OBUE}}</math> the <i>basic limit</i> within the <i>Inter RF Bandwidth gaps</i> is calculated as a cumulative sum of contributions from adjacent sub-blocks or RF Bandwidth on each side of the <i>Inter RF Bandwidth gap</i>.</p> <p>NOTE 3: For operation with an E-UTRA 1.4 or 3 MHz carrier adjacent to the <i>Base Station RF Bandwidth edge</i> or the sub-block edge, the limits in table 6.6.5.2.3-2 apply for <math>0 \text{ MHz} \leq \Delta f &lt; 0.15 \text{ MHz}</math>.</p>			

Table 6.6.5.2.3-1b: WA BS OBUE in BC2 bands &gt; 1 GHz – option 1

Frequency offset of measurement filter -3dB point, $\Delta f$	Frequency offset of measurement filter centre frequency, $f_{\text{offset}}$	Basic limit (Note 1, 2)	Measurement bandwidth (Note 10)
$0 \text{ MHz} \leq \Delta f < 5 \text{ MHz}$	$0.05 \text{ MHz} \leq f_{\text{offset}} < 5.05 \text{ MHz}$	$-7 \text{ dBm} - \frac{7}{5} \cdot \left( \frac{f_{\text{offset}}}{\text{MHz}} - 0.05 \right) \text{ dB}$	100 kHz
$5 \text{ MHz} \leq \Delta f < \min(10 \text{ MHz}, \Delta f_{\text{max}})$	$5.05 \text{ MHz} \leq f_{\text{offset}} < \min(10.05 \text{ MHz}, f_{\text{offset}_{\text{max}}})$	-14 dBm	100 kHz
$10 \text{ MHz} \leq \Delta f \leq \Delta f_{\text{max}}$	$10.5 \text{ MHz} \leq f_{\text{offset}} < f_{\text{offset}_{\text{max}}}$	-15 dBm (Note 11)	1MHz
NOTE 1: For MSR TAB connectors supporting non-contiguous spectrum operation within any operating band, the basic limit within sub-block gaps is calculated as a cumulative sum of contributions from adjacent sub blocks on each side of the sub block gap, where the contribution from the far-end sub-block shall be scaled according to the measurement bandwidth of the near-end sub-block. Exception is $\Delta f \geq 10 \text{ MHz}$ from both adjacent sub blocks on each side of the sub-block gap, where the basic limit within sub-block gaps shall be -15dBm/1MHz.			
NOTE 2: For MSR multi band TAB connector with Inter RF Bandwidth gap < $2 \times \Delta f_{\text{OBUE}}$ the basic limit within the Inter RF Bandwidth gaps is calculated as a cumulative sum of contributions from adjacent sub-blocks or RF Bandwidth on each side of the Inter RF Bandwidth gap, where the contribution from the far-end sub-block or RF Bandwidth shall be scaled according to the measurement bandwidth of the near-end sub-block or RF Bandwidth.			
NOTE 3: For operation with an E-UTRA 1.4 or 3 MHz carrier adjacent to the Base Station RF Bandwidth edge or the sub-block edge, the limits in table 6.6.5.2.3-2 apply for $0 \text{ MHz} \leq \Delta f < 0.15 \text{ MHz}$ .			

Table 6.6.5.2.3-2: WA BS OBUE in BC2 bands applicable for: BS operating with E-UTRA 1.4 or 3 MHz carriers adjacent to the Base Station RF Bandwidth edge or the sub-block edge

Frequency offset of measurement filter -3dB point, $\Delta f$	Frequency offset of measurement filter centre frequency, $f_{\text{offset}}$	Basic Limit (NOTE 5, 6)	Measurement bandwidth (NOTE 10)
$0 \text{ MHz} \leq \Delta f < 0.05 \text{ MHz}$	$0.015 \text{ MHz} \leq f_{\text{offset}} < 0.065 \text{ MHz}$	$\text{Max}(5 \text{ dBm} - 60 \cdot \left( \frac{f_{\text{offset}}}{\text{MHz}} - 0.015 \right) \text{ dB}, -14 \text{ dBm})$	30 kHz
$0.05 \text{ MHz} \leq \Delta f < 0.15 \text{ MHz}$	$0.065 \text{ MHz} \leq f_{\text{offset}} < 0.165 \text{ MHz}$	$\text{Max}(2 \text{ dBm} - 160 \cdot \left( \frac{f_{\text{offset}}}{\text{MHz}} - 0.065 \right) \text{ dB}, -14 \text{ dBm})$	30 kHz
NOTE 4: The limits in this table only apply for operation with an E-UTRA 1.4 or 3 MHz carrier adjacent to the Base Station RF Bandwidth edge or the sub-block edge.			
NOTE 5: For MSR TAB connector supporting non-contiguous spectrum operation within any operating band the basic limit within sub-block gaps is calculated as a cumulative sum of contributions from adjacent sub blocks on each side of the sub-block gap.			
NOTE 6: For a MSR multi-band TAB connector with Inter RF Bandwidth gap < $2 \times \Delta f_{\text{OBUE}}$ the basic limit within the Inter RF Bandwidth gaps is calculated as a cumulative sum of contributions from adjacent sub-blocks or Base Station RF Bandwidth on each side of the Inter RF Bandwidth gap.			

**Table 6.6.5.2.3-3: MR BS OBUE in BC2 bands applicable for: BS with maximum output power  $31 < P_{\text{rated,c,cell}} - 10 \cdot \log_{10}(N_{\text{TXU,countedpercell}}) \leq 38$  dBm and not supporting NR; or BS with maximum output power  $31 < P_{\text{rated,c,cell}} - 10 \cdot \log_{10}(N_{\text{TXU,countedpercell}}) \leq 38$  dBm supporting NR, and supporting UTRA**

Frequency offset of measurement filter -3dB point, $\Delta f$	Frequency offset of measurement filter centre frequency, $f_{\text{offset}}$	<i>Basic Limit</i> (NOTE 2, 3)	Measurement bandwidth (NOTE 10)
$0 \text{ MHz} \leq \Delta f < 0.6 \text{ MHz}$ (NOTE 1)	$0.015 \text{ MHz} \leq f_{\text{offset}} < 0.615 \text{ MHz}$	$P_{\text{rated,c,cell}} - 10 \cdot \log_{10}(N_{\text{TXU,countedpercell}}) - 58 \text{ dB} - (5/3) \cdot (f_{\text{offset}}/\text{MHz} - 0,015) \text{ dB}$	30 kHz
$0.6 \text{ MHz} \leq \Delta f < 1 \text{ MHz}$	$0.615 \text{ MHz} \leq f_{\text{offset}} < 1.015 \text{ MHz}$	$P_{\text{rated,c,cell}} - 10 \cdot \log_{10}(N_{\text{TXU,countedpercell}}) - 53 \text{ dB} - 15 \cdot (f_{\text{offset}}/\text{MHz} - 0,215) \text{ dB}$	30 kHz
(NOTE 9)	$1.015 \text{ MHz} \leq f_{\text{offset}} < 1.5 \text{ MHz}$	$P_{\text{rated,c,cell}} - 10 \cdot \log_{10}(N_{\text{TXU,countedpercell}}) - 65 \text{ dB}$	30 kHz
$1 \text{ MHz} \leq \Delta f \leq 2.8 \text{ MHz}$	$1.5 \text{ MHz} \leq f_{\text{offset}} < 3.3 \text{ MHz}$	$P_{\text{rated,c,cell}} - 10 \cdot \log_{10}(N_{\text{TXU,countedpercell}}) - 52 \text{ dB}$	1 MHz
$2.8 \text{ MHz} \leq \Delta f \leq 5 \text{ MHz}$	$3.3 \text{ MHz} \leq f_{\text{offset}} < 5.5 \text{ MHz}$	$\min(P_{\text{rated,c,cell}} - 10 \cdot \log_{10}(N_{\text{TXU,countedpercell}}) - 52 \text{ dB}, -15 \text{ dBm})$	1 MHz
$5 \text{ MHz} \leq \Delta f \leq \Delta f_{\text{max}}$	$5.5 \text{ MHz} \leq f_{\text{offset}} < f_{\text{offset,max}}$	$P_{\text{rated,c,cell}} - 10 \cdot \log_{10}(N_{\text{TXU,countedpercell}}) - 56 \text{ dB}$	1 MHz

NOTE 1: For operation with an E-UTRA 1.4 or 3 MHz carrier adjacent to the *Base Station RF Bandwidth edge* or the sub-block edge, the limits in table 6.6.5.2.3-5 apply for  $0 \text{ MHz} \leq \Delta f < 0.15 \text{ MHz}$ .

NOTE 2: For a MSR *TAB connector* supporting *non-contiguous spectrum* operation within any operating band the *basic limit* within *sub-block gaps* is calculated as a cumulative sum of contributions from adjacent sub blocks on each side of the *sub-block gap*, where the contribution from the far-end sub-block shall be scaled according to the measurement bandwidth of the near-end sub-block. Exception is  $\Delta f \geq 10 \text{ MHz}$  from both adjacent sub-blocks on each side of the *sub-block gap*, where the *basic limit* within *sub-block gaps* shall be  $(P_{\text{rated,c,cell}} - 10 \cdot \log_{10}(N_{\text{TXU,countedpercell}}) - 56 \text{ dB})/\text{MHz}$ .

NOTE 3: For a MSR *multi-band TAB connector* with *Inter RF Bandwidth gap*  $< 2 \cdot \Delta f_{\text{OBUE}}$  the *basic limit* within the *Inter RF Bandwidth gaps* is calculated as a cumulative sum of contributions from adjacent sub-blocks or *Base Station RF Bandwidth* on each side of the *Inter RF Bandwidth gap*, where the contribution from the far-end sub-block or *Base Station RF Bandwidth* shall be scaled according to the measurement bandwidth of the near-end sub-block or *Base Station RF Bandwidth*.

**Table 6.6.5.2.3-3a: MR BS OBUE in BC2 bands applicable for: BS with maximum output power  $31 < P_{\text{rated,c,cell}} - 10 \cdot \log_{10}(N_{\text{TXU,countedpercell}}) \leq 38$  dBm, supporting NR and not supporting UTRA**

Frequency offset of measurement filter -3dB point, $\Delta f$	Frequency offset of measurement filter centre frequency, $f_{\text{offset}}$	<i>Basic limit</i> (Note 1, 2)	Measurement bandwidth (Note 10)
$0 \text{ MHz} \leq \Delta f < 5 \text{ MHz}$	$0.05 \text{ MHz} \leq f_{\text{offset}} < 5.05 \text{ MHz}$	$P_{\text{rated,c,cell}} - 10 \cdot \log_{10}(N_{\text{TXU,countedpercell}}) - 53 \text{ dB} - (7/5) \cdot (f_{\text{offset}}/\text{MHz} - 0,05) \text{ dB}$	100 kHz
$5 \text{ MHz} \leq \Delta f < \min(10 \text{ MHz}, \Delta f_{\text{max}})$	$5.05 \text{ MHz} \leq f_{\text{offset}} < \min(10.05 \text{ MHz}, f_{\text{offset,max}})$	$P_{\text{rated,c,cell}} - 10 \cdot \log_{10}(N_{\text{TXU,countedpercell}}) - 60 \text{ dB}$	100 kHz
$10 \text{ MHz} \leq \Delta f \leq \Delta f_{\text{max}}$	$10.05 \text{ MHz} \leq f_{\text{offset}} < f_{\text{offset,max}}$	$\min(P_{\text{rated,c,cell}} - 10 \cdot \log_{10}(N_{\text{TXU,countedpercell}}) - 60 \text{ dB}, -25 \text{ dBm})$ (Note 11)	100 kHz

NOTE 1: For MSR *TAB connectors* supporting *non-contiguous spectrum* operation within any operating band the *basic limit* within *sub-block gaps* is calculated as a cumulative sum of contributions from adjacent sub blocks on each side of the *sub block gap*. Exception is  $\Delta f \geq 10 \text{ MHz}$  from both adjacent sub blocks on each side of the *sub-block gap*, where the *basic limit* within *sub-block gaps* shall be  $\min(P_{\text{rated,c,cell}} - 10 \cdot \log_{10}(N_{\text{TXU,countedpercell}}) - 60 \text{ dB}, -25 \text{ dBm}) / 100 \text{ kHz}$ .

NOTE 2: For MSR *multi band TAB connector* with *Inter RF Bandwidth gap*  $< 2 \cdot \Delta f_{\text{OBUE}}$  the *basic limit* within the *Inter RF Bandwidth gaps* is calculated as a cumulative sum of contributions from adjacent sub-blocks or *RF Bandwidth* on each side of the *Inter RF Bandwidth gap*.

NOTE 3: For operation with an E-UTRA 1.4 or 3 MHz carrier adjacent to the *Base Station RF Bandwidth edge* or the sub-block edge, the limits in table 6.6.5.2.3-5 apply for  $0 \text{ MHz} \leq \Delta f < 0.15 \text{ MHz}$ .

**Table 6.6.5.2.3-4: MR BS OBUE in BC2 bands applicable for: BS with maximum output power  $P_{\text{rated,c,cell}} - 10 \cdot \log_{10}(N_{\text{TXU,countedpercell}}) \leq 31$  dBm and not supporting NR, or BS with maximum output power  $P_{\text{rated,c,cell}} - 10 \cdot \log_{10}(N_{\text{TXU,countedpercell}}) \leq 31$  dBm supporting NR, and supporting UTRA**

Frequency offset of measurement filter -3dB point, $\Delta f$	Frequency offset of measurement filter centre frequency, $f_{\text{offset}}$	Basic Limit (NOTE 2, 3)	Measurement bandwidth (NOTE 10)
$0 \text{ MHz} \leq \Delta f < 0.6 \text{ MHz}$ (NOTE 1)	$0.015 \text{ MHz} \leq f_{\text{offset}} < 0.615 \text{ MHz}$	$-27 \text{ dBm} - \frac{5}{3} \left( \frac{f_{\text{offset}}}{\text{MHz}} - 0.015 \right) \text{ dB}$	30 kHz
$0.6 \text{ MHz} \leq \Delta f < 1 \text{ MHz}$	$0.615 \text{ MHz} \leq f_{\text{offset}} < 1.015 \text{ MHz}$	$-22 \text{ dBm} - 15 \cdot \left( \frac{f_{\text{offset}}}{\text{MHz}} - 0.215 \right) \text{ dB}$	30 kHz
(NOTE 9)	$1.015 \text{ MHz} \leq f_{\text{offset}} < 1.5 \text{ MHz}$	-34 dBm	30 kHz
$1 \text{ MHz} \leq \Delta f \leq 5 \text{ MHz}$	$1.5 \text{ MHz} \leq f_{\text{offset}} < 5.5 \text{ MHz}$	-21 dBm	1 MHz
$5 \text{ MHz} \leq \Delta f \leq \Delta f_{\text{max}}$	$5.5 \text{ MHz} \leq f_{\text{offset}} < f_{\text{offset,max}}$	-25 dBm	1 MHz
NOTE 1: For operation with an E-UTRA 1.4 or 3 MHz carrier adjacent to the <i>Base Station RF Bandwidth edge</i> or the sub-block edge, the limits in table 6.6.5.2.3-6 apply for $0 \text{ MHz} \leq \Delta f < 0.15 \text{ MHz}$ .			
NOTE 2: For a MSR <i>TAB connector</i> supporting <i>non-contiguous spectrum</i> operation within any operating band the <i>basic limit</i> within <i>sub-block gaps</i> is calculated as a cumulative sum of contributions from adjacent sub blocks on each side of the <i>sub-block gap</i> , where the contribution from the far-end sub-block shall be scaled according to the measurement bandwidth of the near-end sub-block. Exception is $\Delta f \geq 10 \text{ MHz}$ from both adjacent sub-blocks on each side of the <i>sub-block gap</i> , where the <i>basic limit</i> within <i>sub-block gaps</i> shall be -25dBm/MHz.			
NOTE 3: For a MSR <i>multi-band TAB connector</i> with <i>Inter RF Bandwidth gap</i> $< 2 \times \Delta f_{\text{OBUE}}$ the <i>basic limit</i> within the <i>Inter RF Bandwidth gaps</i> is calculated as a cumulative sum of contributions from adjacent sub-blocks or <i>Base Station RF Bandwidth</i> on each side of the <i>Inter RF Bandwidth gap</i> , where the contribution from the far-end sub-block or <i>Base Station RF Bandwidth</i> shall be scaled according to the measurement bandwidth of the near-end sub-block or <i>Base Station RF Bandwidth</i> .			

**Table 6.6.5.2.3-4a: MR BS OBUE in BC2 bands applicable for: BS with maximum output power  $P_{\text{rated,c,cell}} - 10 \cdot \log_{10}(N_{\text{TXU,countedpercell}}) \leq 31$  dBm, supporting NR and not supporting UTRA**

Frequency offset of measurement filter -3dB point, $\Delta f$	Frequency offset of measurement filter centre frequency, $f_{\text{offset}}$	Basic limit (Note 1, 2)	Measurement bandwidth (Note 10)
$0 \text{ MHz} \leq \Delta f < 5 \text{ MHz}$	$0.05 \text{ MHz} \leq f_{\text{offset}} < 5.05 \text{ MHz}$	$-22 \text{ dBm} - \frac{7}{5} \left( \frac{f_{\text{offset}}}{\text{MHz}} - 0.05 \right) \text{ dB}$	100 kHz
$5 \text{ MHz} \leq \Delta f < \min(10 \text{ MHz}, \Delta f_{\text{max}})$	$5.05 \text{ MHz} \leq f_{\text{offset}} < \min(10.05 \text{ MHz}, f_{\text{offset,max}})$	-29 dBm	100 kHz
$10 \text{ MHz} \leq \Delta f \leq \Delta f_{\text{max}}$	$10.05 \text{ MHz} \leq f_{\text{offset}} < f_{\text{offset,max}}$	-29 dBm (Note 11)	100 kHz
NOTE 1: For MSR <i>TAB connectors</i> supporting <i>non-contiguous spectrum</i> operation within any operating band the <i>basic limit</i> within <i>sub-block gaps</i> is calculated as a cumulative sum of contributions from adjacent sub blocks on each side of the <i>sub block gap</i> . Exception is $\Delta f \geq 10 \text{ MHz}$ from both adjacent sub blocks on each side of the <i>sub-block gap</i> , where the <i>basic limit</i> within <i>sub-block gaps</i> shall be -29dBm/100kHz.			
NOTE 2: For MSR <i>multi band TAB connector</i> with <i>Inter RF Bandwidth gap</i> $< 2 \times \Delta f_{\text{OBUE}}$ the <i>basic limit</i> within the <i>Inter RF Bandwidth gaps</i> is calculated as a cumulative sum of contributions from adjacent sub-blocks or <i>RF Bandwidth</i> on each side of the <i>Inter RF Bandwidth gap</i> .			
NOTE 3: For operation with an E-UTRA 1.4 or 3 MHz carrier adjacent to the <i>Base Station RF Bandwidth edge</i> or the sub-block edge, the limits in table 6.6.5.2.3-5 apply for $0 \text{ MHz} \leq \Delta f < 0.15 \text{ MHz}$ .			

**Table 6.6.5.2.3-5: MR BS OBUE in BC2 bands applicable for: BS with maximum output power  $31 < P_{\text{rated,c,cell}} - 10 \cdot \log_{10}(N_{\text{TXU,countedpercell}}) \leq 38$  dBm and operating E-UTRA 1.4 or 3 MHz carriers adjacent to the Base Station RF Bandwidth edge or the sub-block edge**

Frequency offset of measurement filter -3dB point, $\Delta f$	Frequency offset of measurement filter centre frequency, $f_{\text{offset}}$	Basic Limit (NOTE 5, 6)	Measurement bandwidth (NOTE 10)
$0 \text{ MHz} \leq \Delta f < 0.05 \text{ MHz}$	$0.015 \text{ MHz} \leq f_{\text{offset}} < 0.065 \text{ MHz}$	$P_{\text{rated,c,cell}} - 10 \cdot \log_{10}(N_{\text{TXU,countedpercell}}) - 38 \text{ dB} - 60 \cdot (f_{\text{offset}} / \text{MHz} - 0,015) \text{ dB}$	30 kHz
$0.05 \text{ MHz} \leq \Delta f < 0.15 \text{ MHz}$	$0.065 \text{ MHz} \leq f_{\text{offset}} < 0.165 \text{ MHz}$	$P_{\text{rated,c,cell}} - 10 \cdot \log_{10}(N_{\text{TXU,countedpercell}}) - 41 \text{ dB} - 160 \cdot (f_{\text{offset}} / \text{MHz} - 0,065) \text{ dB}$	30 kHz

NOTE 4: The limits in this table only apply for operation with an E-UTRA 1.4 or 3 MHz carrier adjacent to the Base Station RF Bandwidth edge or the sub-block edge.

NOTE 5: For a MSR TAB connector supporting non-contiguous spectrum operation within any operating band the basic limit within sub-block gaps is calculated as a cumulative sum of contributions from adjacent sub blocks on each side of the sub-block gap.

NOTE 6: For a MSR multi-band TAB connector with Inter RF Bandwidth gap  $< 2 \times \Delta f_{\text{OBUE}}$  the basic limit within the Inter RF Bandwidth gaps is calculated as a cumulative sum of contributions from adjacent sub-blocks or Base Station RF Bandwidth on each side of the Inter RF Bandwidth gap.

**Table 6.6.5.2.3-6: MR BS OBUE in BC2 bands applicable for: BS with maximum output power  $P_{\text{rated,c,cell}} - 10 \cdot \log_{10}(N_{\text{TXU,countedpercell}}) \leq 31$  dBm and operating E-UTRA 1.4 or 3 MHz carriers adjacent to the Base Station RF Bandwidth edge or the sub-block edge**

Frequency offset of measurement filter -3dB point, $\Delta f$	Frequency offset of measurement filter centre frequency, $f_{\text{offset}}$	Basic Limit (NOTE 5, 6)	Measurement bandwidth (NOTE 10)
$0 \text{ MHz} \leq \Delta f < 0.05 \text{ MHz}$	$0.015 \text{ MHz} \leq f_{\text{offset}} < 0.065 \text{ MHz}$	$\text{Max}(-7 \text{ dBm} - 60 \cdot \left( \frac{f_{\text{offset}}}{\text{MHz}} - 0.015 \right) \text{ dB}, -27 \text{ dBm})$	30 kHz
$0.05 \text{ MHz} \leq \Delta f < 0.15 \text{ MHz}$	$0.065 \text{ MHz} \leq f_{\text{offset}} < 0.165 \text{ MHz}$	$\text{Max}(-10 \text{ dBm} - 160 \cdot \left( \frac{f_{\text{offset}}}{\text{MHz}} - 0.065 \right) \text{ dB}, -27 \text{ dBm})$	30 kHz

NOTE 4: The limits in this table only apply for operation with an E-UTRA 1.4 or 3 MHz carrier adjacent to the Base Station RF Bandwidth edge or the sub-block edge.

NOTE 5: For a MSR TAB connector supporting non-contiguous spectrum operation within any operating band the basic limit within sub-block gaps is calculated as a cumulative sum of contributions from adjacent sub blocks on each side of the sub-block gap.

NOTE 6: For a MSR multi-band TAB connector with Inter RF Bandwidth gap  $< 2 \times \Delta f_{\text{OBUE}}$  the basic limit within the Inter RF Bandwidth gaps is calculated as a cumulative sum of contributions from adjacent sub-blocks or Base Station RF Bandwidth on each side of the Inter RF Bandwidth gap.

Table 6.6.5.2.3-7: LA BS OBUE in BC2 bands

Frequency offset of measurement filter -3dB point, $\Delta f$	Frequency offset of measurement filter centre frequency, $f_{\text{offset}}$	Basic Limit (NOTE 2, 3)	Measurement bandwidth (NOTE 10)
$0 \text{ MHz} \leq \Delta f < 5 \text{ MHz}$ (NOTE 1)	$0.05 \text{ MHz} \leq f_{\text{offset}} < 5.05 \text{ MHz}$	$-30 \text{ dBm} - \frac{7}{5} \left( \frac{f_{\text{offset}}}{\text{MHz}} - 0.05 \right) \text{ dB}$	100 kHz
$5 \text{ MHz} \leq \Delta f < \min(10 \text{ MHz}, \Delta f_{\text{max}})$	$5.05 \text{ MHz} \leq f_{\text{offset}} < \min(10.05 \text{ MHz}, f_{\text{offset}_{\text{max}}})$	-37 dBm	100 kHz
$10 \text{ MHz} \leq \Delta f \leq \Delta f_{\text{max}}$	$10.05 \text{ MHz} \leq f_{\text{offset}} < f_{\text{offset}_{\text{max}}}$	-37 dBm (NOTE 11)	100 kHz

NOTE 1: For operation with an E-UTRA 1.4 or 3 MHz carrier adjacent to the *Base Station RF Bandwidth edge* or the sub-block edge, the limits in table 6.6.5.2.3-8 apply for  $0 \text{ MHz} \leq \Delta f < 0.16 \text{ MHz}$ .

NOTE 2: For a MSR *TAB connector* supporting *non-contiguous spectrum* operation within any operating band the *basic limit* within *sub-block gaps* is calculated as a cumulative sum of contributions from adjacent sub blocks on each side of the *sub-block gap*. Exception is  $\Delta f \geq 10 \text{ MHz}$  from both adjacent sub blocks on each side of the *sub-block gap*, where the *basic limit* within *sub-block gaps* shall be -37dBm/100 kHz.

NOTE 3: For a MSR *multi-band TAB connector* with *Inter RF Bandwidth gap*  $< 2 \times \Delta f_{\text{OBUE}}$  the *basic limit* within the *Inter RF Bandwidth gaps* is calculated as a cumulative sum of contributions from adjacent sub-blocks or *Base Station RF Bandwidth* on each side of the *Inter RF Bandwidth gap*.

Table 6.6.5.2.3-8: LA BS OBUE in BC2 bands applicable for: BS operating with E-UTRA 1.4 or 3 MHz carriers adjacent to the *Base Station RF Bandwidth edge* or the sub-block edge

Frequency offset of measurement filter -3dB point, $\Delta f$	Frequency offset of measurement filter centre frequency, $f_{\text{offset}}$	Basic Limit (NOTE 5, 6)	Measurement bandwidth (NOTE 10)
$0 \text{ MHz} \leq \Delta f < 0.05 \text{ MHz}$	$0.015 \text{ MHz} \leq f_{\text{offset}} < 0.065 \text{ MHz}$	$\text{Max}(-14 \text{ dBm} - 60 \cdot \left( \frac{f_{\text{offset}}}{\text{MHz}} - 0.015 \right) \text{ dB}, -35 \text{ dBm})$	30 kHz
$0.05 \text{ MHz} \leq \Delta f < 0.16 \text{ MHz}$	$0.065 \text{ MHz} \leq f_{\text{offset}} < 0.175 \text{ MHz}$	$\text{Max}(-17 \text{ dBm} - 160 \cdot \left( \frac{f_{\text{offset}}}{\text{MHz}} - 0.065 \right) \text{ dB}, -35 \text{ dBm})$	30 kHz

NOTE 4: The limits in this table only apply for operation with an E-UTRA 1.4 or 3 MHz carrier adjacent to the *Base Station RF Bandwidth edge* or the sub-block edge.

NOTE 5: For a MSR *TAB connector* supporting *non-contiguous spectrum* operation within any operating band the *basic limit* within *sub-block gaps* is calculated as a cumulative sum of contributions from adjacent sub blocks on each side of the *sub-block gap*.

NOTE 6: For a MSR *multi-band TAB connector* with *Inter RF Bandwidth gap*  $< 2 \times \Delta f_{\text{OBUE}}$  the *basic limit* within the *Inter RF Bandwidth gaps* is calculated as a cumulative sum of contributions from adjacent sub-blocks or *Base Station RF Bandwidth* on each side of the *Inter RF Bandwidth gap*.

The following notes are common to all subclauses in 6.6.5.2.3:

NOTE 9: This frequency range ensures that the range of values of  $f_{\text{offset}}$  is continuous.

NOTE 10: As a general rule for the requirements in the present subclause, the resolution bandwidth of the measuring equipment should be equal to the measurement bandwidth. However, to improve measurement accuracy, sensitivity and efficiency, the resolution bandwidth may be smaller than the measurement bandwidth. When the resolution bandwidth is smaller than the measurement bandwidth, the result should be integrated over the measurement bandwidth in order to obtain the equivalent noise bandwidth of the measurement bandwidth.

NOTE 11: The requirement is not applicable when  $\Delta f_{\text{max}} < 10 \text{ MHz}$ .

NOTE 12: All limits in table 6.6.5.2.3-1, table 6.6.5.2.3-3, table 6.6.5.2.3-4 and table 6.6.5.2.3-7 are identical to the corresponding limits for Band Category 1 and 3.

#### 6.6.5.2.4 Additional requirements

The MSR operating band unwanted emission *basic limits* for additional requirements are the same as the *basic limits* specified in 3GPP TS 37.104 [9], subclause 6.6.2.4.

#### 6.6.5.3 Minimum requirement for single RAT UTRA operation

There is no operating band unwanted emission requirement for a single RAT UTRA FDD or single RAT UTRA TDD AAS BS.

#### 6.6.5.4 Minimum requirement for single RAT E-UTRA operation

##### 6.6.5.4.1 General

The single RAT E-UTRA operating band unwanted emission *basic limits* are given in subclauses 6.6.5.4.2, 6.6.5.4.3 and 6.6.5.4.4.

The operating band unwanted emission requirements for AAS BS in *single RAT E-UTRA operation* are that for each *TAB connector TX min cell group* and each applicable *basic limit*, the power sum of the emissions at the *TAB connectors* of the *TAB connector TX min cell group* shall not exceed an AAS limit specified as the *basic limit* +  $10\log_{10}(N_{\text{TXU, counted per cell}})$ .

NOTE: Conformance to the AAS BS operating band unwanted emission requirement can be demonstrated by meeting at least one of the following criteria as determined by the manufacturer:

- 1) The sum of the emissions power measured on each *TAB connector* in the *TAB connector TX min cell group* shall be less than or equal to the AAS BS limit as defined in this subclause for the respective frequency span.

Or

- 2) The unwanted emissions power at each *TAB connector* shall be less than or equal to the AAS BS limit as defined in this subclause for the respective frequency span, scaled by  $-10\log_{10}(n)$ , where  $n$  is the number of *TAB connectors* in the *TAB connector TX min cell group*.

The requirements shall apply whatever the type of *TAB connector* is considered (single carrier or multi-carrier) and for all transmission modes foreseen by the manufacturer's specification. In addition, for a *TAB connector* operating in *non-contiguous spectrum*, the requirements apply inside any *sub-block gap*. In addition, for a *multi-band TAB connector* the requirements apply inside any *Inter RF Bandwidth gap*.

The unwanted emission *basic limits* in the part of the *downlink operating band* that falls in the spurious domain are consistent with ITU-R Recommendation SM.329 [14].

Emissions shall use the *basic limits* specified in the tables below, where:

- $\Delta f$  is the separation between the channel edge frequency and the nominal -3dB point of the measuring filter closest to the carrier frequency.
- $f_{\text{offset}}$  is the separation between the channel edge frequency and the centre of the measuring filter.
- $f_{\text{offset}_{\text{max}}}$  is the offset to the frequency  $\Delta f_{\text{OBUE}}$  outside the *downlink operating band*.
- $\Delta f_{\text{max}}$  is equal to  $f_{\text{offset}_{\text{max}}}$  minus half of the bandwidth of the measuring filter.

For a *multi-band TAB connector* inside any *Inter RF Bandwidth gaps* with  $W_{\text{gap}} < 2 \times \Delta f_{\text{OBUE}}$  MHz, a combined *basic limit* shall be applied which is the cumulative sum of the *basic limits* specified at the *Base Station RF Bandwidth edges* on each side of the *Inter RF Bandwidth gap*. The *basic limit* for *Base Station RF Bandwidth edge* is specified in the tables subclause 6.6.5.4.2 to 6.6.5.4.7 below, where in this case:

- $\Delta f$  is the separation between the *Base Station RF Bandwidth edge* frequency and the nominal -3 dB point of the measuring filter closest to the *Base Station RF Bandwidth edge*.
- $f_{\text{offset}}$  is the separation between the *Base Station RF Bandwidth edge* frequency and the centre of the measuring filter.

- $f_{\text{offset}_{\text{max}}}$  is equal to the *Inter RF Bandwidth gap* minus half of the bandwidth of the measuring filter.
- $\Delta f_{\text{max}}$  is equal to  $f_{\text{offset}_{\text{max}}}$  minus half of the bandwidth of the measuring filter.

For *multi-band TAB connector* where multiple bands are mapped on the same antenna connector, the operating band unwanted emission *basic limits* apply also in a supported operating band without any carrier transmitted, in the case where there are carrier(s) transmitted in other supported operating band(s). In this case where there is no carrier transmitted in an operating band, the operating band unwanted emission limit, as defined in the tables of the present subclause for the largest frequency offset ( $\Delta f_{\text{max}}$ ), of a band where there is no carrier transmitted shall apply from 10 MHz below the lowest frequency, up to 10 MHz above the highest frequency of the supported downlink operating band without any carrier transmitted. And no cumulative *basic limit* is applied in the *inter-band gap* between a supported downlink operating band with carrier(s) transmitted and a supported downlink operating band without any carrier transmitted.

For a multicarrier E-UTRA *TAB connector* or a *TAB connector* configured for intra-band contiguous or non-contiguous *carrier aggregation* the definitions above apply to the lower edge of the carrier transmitted at the lowest carrier frequency and the upper edge of the carrier transmitted at the highest carrier frequency within a specified frequency band.

In addition inside any *sub-block gap* for a *TAB connector* operating in *non-contiguous spectrum*, a combined *basic limit* shall be applied which is the cumulative sum of the *basic limits* specified for the adjacent sub blocks on each side of the *sub-block gap*. The *basic limit* for each sub block is specified in the tables subclause 6.6.5.4.2 to 6.6.5.4.7 below, where in this case:

- $\Delta f$  is the separation between the sub block edge frequency and the nominal -3 dB point of the measuring filter closest to the sub block edge.
- $f_{\text{offset}}$  is the separation between the sub block edge frequency and the centre of the measuring filter.
- $f_{\text{offset}_{\text{max}}}$  is equal to the *sub-block gap* bandwidth minus half of the bandwidth of the measuring filter.
- $\Delta f_{\text{max}}$  is equal to  $f_{\text{offset}_{\text{max}}}$  minus half of the bandwidth of the measuring filter.

For an AAS BS of Wide Area BS class, the requirements of either subclause 6.6.5.4.2 (Category A limits) or subclause 6.6.5.4.3 (Category B limits) shall apply.

For an AAS BS of Local Area BS class, the requirements of subclause 6.6.5.4.4 shall apply (Category A and B).

For an AAS BS of Medium Range BS class, the requirements in subclause 6.6.5.4.5 shall apply (Category A and B).

The application of either Category A or Category B *basic limits* shall be the same as for Transmitter spurious emissions (Mandatory Requirements) in subclause 6.6.6.

## 6.6.5.4.2 Basic limits for Wide Area BS (Category A)

For E-UTRA *TAB connector* operating in Bands 5, 6, 8, 12, 13, 14, 17, 18, 19, 26, 27, 28, 29, 31, 44, 68, 71, 72, 73, 85, 87, 88 the *basic limits* are specified in tables 6.6.5.4.2-1 to 6.6.5.4.2-3.

**Table 6.6.5.4.2-1: Wide Area BS operating band unwanted emission limits for 1.4 MHz channel bandwidth (E-UTRA bands <1GHz) for Category A**

Frequency offset of measurement filter -3dB point, $\Delta f$	Frequency offset of measurement filter centre frequency, $f_{\text{offset}}$	Basic limit (NOTE 1, 2)	Measurement bandwidth (NOTE 5)
$0 \text{ MHz} \leq \Delta f < 1.4 \text{ MHz}$	$0.05 \text{ MHz} \leq f_{\text{offset}} < 1.45 \text{ MHz}$	$-1\text{dBm} - \frac{10}{1.4} \cdot \left( \frac{f_{\text{offset}}}{\text{MHz}} - 0.05 \right) \text{dB}$	100 kHz
$1.4 \text{ MHz} \leq \Delta f < 2.8 \text{ MHz}$	$1.45 \text{ MHz} \leq f_{\text{offset}} < 2.85 \text{ MHz}$	-11 dBm	100 kHz
$2.8 \text{ MHz} \leq \Delta f \leq \Delta f_{\text{max}}$	$2.85 \text{ MHz} \leq f_{\text{offset}} < f_{\text{offset}_{\text{max}}}$	-13 dBm	100 kHz

NOTE 1: For a *TAB connector* supporting *non-contiguous spectrum* operation within any operating band, the *basic limit* within *sub-block gaps* is calculated as a cumulative sum of contributions from adjacent sub blocks on each side of the *sub-block gap*. Exception is  $\Delta f \geq 10\text{MHz}$  from both adjacent sub blocks on each side of the *sub-block gap*, where the *basic limit* within *sub-block gaps* shall be -13dBm/100kHz.

NOTE 2: For a *multi-band TAB connector* with *Inter RF Bandwidth gap*  $< 2 \times \Delta f_{\text{OBUE}}$  the *basic limit* within the *Inter RF Bandwidth gaps* is calculated as a cumulative sum of contributions from adjacent sub-blocks or *Base Station RF Bandwidth* on each side of the *Inter RF Bandwidth gap*.

**Table 6.6.5.4.2-2: Wide Area BS operating band unwanted emission limits for 3 MHz channel bandwidth (E-UTRA bands <1GHz) for Category A**

Frequency offset of measurement filter -3dB point, $\Delta f$	Frequency offset of measurement filter centre frequency, $f_{\text{offset}}$	Basic limit (NOTE 1, 2)	Measurement bandwidth (NOTE 5)
$0 \text{ MHz} \leq \Delta f < 3 \text{ MHz}$	$0.05 \text{ MHz} \leq f_{\text{offset}} < 3.05 \text{ MHz}$	$-5\text{dBm} - \frac{10}{3} \cdot \left( \frac{f_{\text{offset}}}{\text{MHz}} - 0.05 \right) \text{dB}$	100 kHz
$3 \text{ MHz} \leq \Delta f < 6 \text{ MHz}$	$3.05 \text{ MHz} \leq f_{\text{offset}} < 6.05 \text{ MHz}$	-15 dBm	100 kHz
$6 \text{ MHz} \leq \Delta f \leq \Delta f_{\text{max}}$	$6.05 \text{ MHz} \leq f_{\text{offset}} < f_{\text{offset}_{\text{max}}}$	-13 dBm	100 kHz

NOTE 1: For a *TAB connector* supporting *non-contiguous spectrum* operation within any operating band, the *basic limit* within *sub-block gaps* is calculated as a cumulative sum of contributions from adjacent sub blocks on each side of the *sub-block gap*. Exception is  $\Delta f \geq 10\text{MHz}$  from both adjacent sub blocks on each side of the *sub-block gap*, where the *basic limit* within *sub-block gaps* shall be -13dBm/100kHz.

NOTE 2: For a *multi-band TAB connector* with *Inter RF Bandwidth gap*  $< 2 \times \Delta f_{\text{OBUE}}$  the *basic limit* within the *Inter RF Bandwidth gaps* is calculated as a cumulative sum of contributions from adjacent sub-blocks or *Base Station RF Bandwidth* on each side of the *Inter RF Bandwidth gap*.

**Table 6.6.5.4.2-3: Wide Area BS operating band unwanted emission limits for 5, 10, 15 and 20 MHz channel bandwidth (E-UTRA bands <1GHz) for Category A**

Frequency offset of measurement filter -3dB point, $\Delta f$	Frequency offset of measurement filter centre frequency, $f_{\text{offset}}$	basic limit (NOTE 1, 2)	Measurement bandwidth (NOTE 5)
$0 \text{ MHz} \leq \Delta f < 5 \text{ MHz}$	$0.05 \text{ MHz} \leq f_{\text{offset}} < 5.05 \text{ MHz}$	$-7\text{dBm} - \frac{7}{5} \cdot \left( \frac{f_{\text{offset}}}{\text{MHz}} - 0.05 \right) \text{dB}$	100 kHz
$5 \text{ MHz} \leq \Delta f < \min(10 \text{ MHz}, \Delta f_{\text{max}})$	$5.05 \text{ MHz} \leq f_{\text{offset}} < \min(10.05 \text{ MHz}, f_{\text{offset}_{\text{max}}})$	-14 dBm	100 kHz
$10 \text{ MHz} \leq \Delta f \leq \Delta f_{\text{max}}$	$10.05 \text{ MHz} \leq f_{\text{offset}} < f_{\text{offset}_{\text{max}}}$	-13 dBm (NOTE 7)	100 kHz

NOTE 1: For a *TAB connector* supporting *non-contiguous spectrum* operation within any operating band, the *basic limit* within *sub-block gaps* is calculated as a cumulative sum of contributions from adjacent sub blocks on each side of the *sub-block gap*. Exception is  $\Delta f \geq 10\text{MHz}$  from both adjacent sub blocks on each side of the *sub-block gap*, where the *basic limit* within *sub-block gaps* shall be -13dBm/100kHz.

NOTE 2: For a *multi-band TAB connector* with *Inter RF Bandwidth gap*  $< 2 \times \Delta f_{\text{OBUE}}$  the *basic limit* within the *Inter RF Bandwidth gaps* is calculated as a cumulative sum of contributions from adjacent sub-blocks or *Base Station RF Bandwidth* on each side of the *Inter RF Bandwidth gap*.

For a E-UTRA *TAB connector* operating in Bands 1, 2, 3, 4, 7, 9, 10, 11, 21, 22, 23, 24, 25, 30, 32, 33, 34, 35, 36, 37, 38, 39, 40, 41, 42, 43, 45, 48, 50, 52, 65, 66, 69, 70, 74, 75 emissions shall use the *basic limits* specified in tables 6.6.5.4.2-4 to 6.6.5.4.2-6:

**Table 6.6.5.4.2-4: Wide Area BS operating band unwanted emission limits for 1.4 MHz channel bandwidth (E-UTRA bands >1GHz) for Category A**

Frequency offset of measurement filter -3dB point, $\Delta f$	Frequency offset of measurement filter centre frequency, $f_{\text{offset}}$	<i>basic limit</i> (NOTE 1, 2)	Measurement bandwidth (NOTE 5)
$0 \text{ MHz} \leq \Delta f < 1.4 \text{ MHz}$	$0.05 \text{ MHz} \leq f_{\text{offset}} < 1.45 \text{ MHz}$	$-1\text{dBm} - \frac{10}{1.4} \cdot \left( \frac{f_{\text{offset}}}{\text{MHz}} - 0.05 \right) \text{dB}$	100 kHz
$1.4 \text{ MHz} \leq \Delta f < 2.8 \text{ MHz}$	$1.45 \text{ MHz} \leq f_{\text{offset}} < 2.85 \text{ MHz}$	-11 dBm	100 kHz
$2.8 \text{ MHz} \leq \Delta f \leq \Delta f_{\text{max}}$	$3.3 \text{ MHz} \leq f_{\text{offset}} < f_{\text{offset}_{\text{max}}}$	-13 dBm	1MHz
NOTE 1: For a <i>TAB connector</i> supporting <i>non-contiguous spectrum</i> operation within any operating band, the <i>basic limit</i> within <i>sub-block gaps</i> is calculated as a cumulative sum of contributions from adjacent sub blocks on each side of the <i>sub-block gap</i> , where the contribution from the far-end sub-block shall be scaled according to the measurement bandwidth of the near-end sub-block. Exception is $\Delta f \geq 10\text{MHz}$ from both adjacent sub blocks on each side of the <i>sub-block gap</i> , where the <i>basic limit</i> within <i>sub-block gaps</i> shall be -13dBm/1MHz.			
NOTE 2: For a <i>multi-band TAB connector</i> with <i>Inter RF Bandwidth gap</i> $< 2 \times \Delta f_{\text{OBUE}}$ the <i>basic limit</i> within the <i>Inter RF Bandwidth gaps</i> is calculated as a cumulative sum of contributions from adjacent sub-blocks or <i>Base Station RF Bandwidth</i> on each side of the <i>Inter RF Bandwidth gap</i> , where the contribution from the far-end sub-block or <i>RF Bandwidth</i> shall be scaled according to the measurement bandwidth of the near-end sub-block or <i>Base Station RF Bandwidth</i> .			

**Table 6.6.5.4.2-5: Wide Area BS operating band unwanted emission limits for 3 MHz channel bandwidth (E-UTRA bands >1GHz) for Category A**

Frequency offset of measurement filter -3dB point, $\Delta f$	Frequency offset of measurement filter centre frequency, $f_{\text{offset}}$	<i>basic limit</i> (NOTE 1, 2)	Measurement bandwidth (NOTE 5)
$0 \text{ MHz} \leq \Delta f < 3 \text{ MHz}$	$0.05 \text{ MHz} \leq f_{\text{offset}} < 3.05 \text{ MHz}$	$-5\text{dBm} - \frac{10}{3} \cdot \left( \frac{f_{\text{offset}}}{\text{MHz}} - 0.05 \right) \text{dB}$	100 kHz
$3 \text{ MHz} \leq \Delta f < 6 \text{ MHz}$	$3.05 \text{ MHz} \leq f_{\text{offset}} < 6.05 \text{ MHz}$	-15 dBm	100 kHz
$6 \text{ MHz} \leq \Delta f \leq \Delta f_{\text{max}}$	$6.5 \text{ MHz} \leq f_{\text{offset}} < f_{\text{offset}_{\text{max}}}$	-13 dBm	1MHz
NOTE 1: For a <i>TAB connector</i> supporting <i>non-contiguous spectrum</i> operation within any operating band, the <i>basic limit</i> within <i>sub-block gaps</i> is calculated as a cumulative sum of contributions from adjacent sub blocks on each side of the <i>sub-block gap</i> , where the contribution from the far-end sub-block shall be scaled according to the measurement bandwidth of the near-end sub-block. Exception is $\Delta f \geq 10\text{MHz}$ from both adjacent sub blocks on each side of the <i>sub-block gap</i> , where the <i>basic limit</i> within <i>sub-block gaps</i> shall be -13dBm/1MHz.			
NOTE 2: For a <i>multi-band TAB connector</i> with <i>Inter RF Bandwidth gap</i> $< 2 \times \Delta f_{\text{OBUE}}$ the <i>basic limit</i> within the <i>Inter RF Bandwidth gaps</i> is calculated as a cumulative sum of contributions from adjacent sub-blocks or <i>Base Station RF Bandwidth</i> on each side of the <i>Inter RF Bandwidth gap</i> , where the contribution from the far-end sub-block or <i>Base Station RF Bandwidth</i> shall be scaled according to the measurement bandwidth of the near-end sub-block or <i>Base Station RF Bandwidth</i> .			

**Table 6.6.5.4.2-6: Wide Area BS operating band unwanted emission limits for 5, 10, 15 and 20 MHz channel bandwidth (E-UTRA bands >1GHz) for Category A**

Frequency offset of measurement filter -3dB point, $\Delta f$	Frequency offset of measurement filter centre frequency, $f_{\text{offset}}$	<i>basic limit</i> (NOTE 1, 2)	Measurement bandwidth (NOTE 5)
$0 \text{ MHz} \leq \Delta f < 5 \text{ MHz}$	$0.05 \text{ MHz} \leq f_{\text{offset}} < 5.05 \text{ MHz}$	$-7 \text{ dBm} - \frac{7}{5} \cdot \left( \frac{f_{\text{offset}}}{\text{MHz}} - 0.05 \right) \text{ dB}$	100 kHz
$5 \text{ MHz} \leq \Delta f < \min(10 \text{ MHz}, \Delta f_{\text{max}})$	$5.05 \text{ MHz} \leq f_{\text{offset}} < \min(10.05 \text{ MHz}, f_{\text{offset}_{\text{max}}})$	-14 dBm	100 kHz
$10 \text{ MHz} \leq \Delta f \leq \Delta f_{\text{max}}$	$10.5 \text{ MHz} \leq f_{\text{offset}} < f_{\text{offset}_{\text{max}}}$	-13 dBm (NOTE 7)	1MHz
<p>NOTE 1: For a <i>TAB connector</i> supporting <i>non-contiguous spectrum</i> operation within any operating band, the <i>basic limit</i> within <i>sub-block gaps</i> is calculated as a cumulative sum of contributions from adjacent sub blocks on each side of the <i>sub-block gap</i>, where the contribution from the far-end sub-block shall be scaled according to the measurement bandwidth of the near-end sub-block. Exception is <math>\Delta f \geq 10\text{MHz}</math> from both adjacent sub blocks on each side of the <i>sub-block gap</i>, where the <i>basic limit</i> within <i>sub-block gaps</i> shall be -13dBm/1MHz.</p> <p>NOTE 2: For a <i>multi-band TAB connector</i> with <i>Inter RF Bandwidth gap</i> <math>&lt; 2 \times \Delta f_{\text{OBUe}}</math> the <i>basic limit</i> within the <i>Inter RF Bandwidth gaps</i> is calculated as a cumulative sum of contributions from adjacent sub-blocks or <i>Base Station RF Bandwidth</i> on each side of the <i>Inter RF Bandwidth gap</i>, where the contribution from the far-end sub-block or <i>Base Station RF Bandwidth</i> shall be scaled according to the measurement bandwidth of the near-end sub-block or <i>Base Station RF Bandwidth</i>.</p>			

### 6.6.5.4.3 Basic limits for Wide Area BS (Category B)

#### 6.6.5.4.3.1 General

For Category B Operating band unwanted emissions, there are two options for the *basic limits* that may be applied regionally. Either the *basic limits* in subclause 6.6.3.2.1 or subclause 6.6.3.2.2 shall be applied.

#### 6.6.5.4.3.2 Category B requirements (Option 1)

For a E-UTRA *TAB connector* operating in Bands 5, 8, 12, 13, 14, 17, 20, 26, 27, 28, 29, 31, 44, 67, 68, 71, 72, 73, 85, 87, 88 emissions shall use the *basic limits* specified in tables 6.6.5.4.3.2-1 to 6.6.5.4.3.2-3:

**Table 6.6.5.4.3.2-1: Wide Area BS operating band unwanted emission limits for 1.4 MHz channel bandwidth (E-UTRA bands <1GHz) for Category B**

Frequency offset of measurement filter -3dB point, $\Delta f$	Frequency offset of measurement filter centre frequency, $f_{\text{offset}}$	<i>basic limit</i> (NOTE 1, 2)	Measurement bandwidth (NOTE 5)
$0 \text{ MHz} \leq \Delta f < 1.4 \text{ MHz}$	$0.05 \text{ MHz} \leq f_{\text{offset}} < 1.45 \text{ MHz}$	$-1 \text{ dBm} - \frac{10}{1.4} \cdot \left( \frac{f_{\text{offset}}}{\text{MHz}} - 0.05 \right) \text{ dB}$	100 kHz
$1.4 \text{ MHz} \leq \Delta f < 2.8 \text{ MHz}$	$1.45 \text{ MHz} \leq f_{\text{offset}} < 2.85 \text{ MHz}$	-11 dBm	100 kHz
$2.8 \text{ MHz} \leq \Delta f \leq \Delta f_{\text{max}}$	$2.85 \text{ MHz} \leq f_{\text{offset}} < f_{\text{offset}_{\text{max}}}$	-16 dBm	100 kHz
<p>NOTE 1: For a <i>TAB connector</i> supporting <i>non-contiguous spectrum</i> operation within any operating band, the <i>basic limit</i> within <i>sub-block gaps</i> is calculated as a cumulative sum of contributions from adjacent sub blocks on each side of the <i>sub-block gap</i>. Exception is <math>\Delta f \geq 10\text{MHz}</math> from both adjacent sub blocks on each side of the <i>sub-block gap</i>, where the <i>basic limit</i> within <i>sub-block gaps</i> shall be -16dBm/100kHz.</p> <p>NOTE 2: For a <i>multi-band TAB connector</i> with <i>Inter RF Bandwidth gap</i> <math>&lt; 2 \times \Delta f_{\text{OBUe}}</math> the <i>basic limit</i> within the <i>Inter RF Bandwidth gaps</i> is calculated as a cumulative sum of contributions from adjacent sub-blocks or <i>Base Station RF Bandwidth</i> on each side of the <i>Inter RF Bandwidth gap</i>.</p>			

**Table 6.6.5.4.3.2-2: Wide Area BS operating band unwanted emission limits for 3 MHz *channel bandwidth* (E-UTRA bands <1GHz) for Category B**

Frequency offset of measurement filter -3dB point, $\Delta f$	Frequency offset of measurement filter centre frequency, $f_{\text{offset}}$	<i>basic limit</i> (NOTE 1, 2)	Measurement bandwidth (NOTE 5)
$0 \text{ MHz} \leq \Delta f < 3 \text{ MHz}$	$0.05 \text{ MHz} \leq f_{\text{offset}} < 3.05 \text{ MHz}$	$-5 \text{ dBm} - \frac{10}{3} \cdot \left( \frac{f_{\text{offset}}}{\text{MHz}} - 0.05 \right) \text{ dB}$	100 kHz
$3 \text{ MHz} \leq \Delta f < 6 \text{ MHz}$	$3.05 \text{ MHz} \leq f_{\text{offset}} < 6.05 \text{ MHz}$	-15 dBm	100 kHz
$6 \text{ MHz} \leq \Delta f \leq \Delta f_{\text{max}}$	$6.05 \text{ MHz} \leq f_{\text{offset}} < f_{\text{offset}_{\text{max}}}$	-16 dBm	100 kHz
NOTE 1: For a <i>TAB connector</i> supporting <i>non-contiguous spectrum</i> operation within any operating band, the <i>basic limit</i> within <i>sub-block gaps</i> is calculated as a cumulative sum of contributions from adjacent sub blocks on each side of the <i>sub-block gap</i> . Exception is $\Delta f \geq 10 \text{ MHz}$ from both adjacent sub blocks on each side of the <i>sub-block gap</i> , where the <i>basic limit</i> within <i>sub-block gaps</i> shall be -16dBm/100kHz.			
NOTE 2: For a <i>multi-band TAB connector</i> with <i>Inter RF Bandwidth gap</i> $< 2 \times \Delta f_{\text{OBUe}}$ the <i>basic limit</i> within the <i>Inter RF Bandwidth gaps</i> is calculated as a cumulative sum of contributions from adjacent sub-blocks or <i>Base Station RF Bandwidth</i> on each side of the <i>Inter RF Bandwidth gap</i> .			

**Table 6.6.5.4.3.2-3: Wide Area BS operating band unwanted emission limits for 5, 10, 15 and 20 MHz *channel bandwidth* (E-UTRA bands <1GHz) for Category B**

Frequency offset of measurement filter -3dB point, $\Delta f$	Frequency offset of measurement filter centre frequency, $f_{\text{offset}}$	<i>basic limit</i> (NOTE 1, 2)	Measurement bandwidth (NOTE 5)
$0 \text{ MHz} \leq \Delta f < 5 \text{ MHz}$	$0.05 \text{ MHz} \leq f_{\text{offset}} < 5.05 \text{ MHz}$	$-7 \text{ dBm} - \frac{7}{5} \cdot \left( \frac{f_{\text{offset}}}{\text{MHz}} - 0.05 \right) \text{ dB}$	100 kHz
$5 \text{ MHz} \leq \Delta f < \min(10 \text{ MHz}, \Delta f_{\text{max}})$	$5.05 \text{ MHz} \leq f_{\text{offset}} < \min(10.05 \text{ MHz}, f_{\text{offset}_{\text{max}}})$	-14 dBm	100 kHz
$10 \text{ MHz} \leq \Delta f \leq \Delta f_{\text{max}}$	$10.05 \text{ MHz} \leq f_{\text{offset}} < f_{\text{offset}_{\text{max}}}$	-16 dBm (NOTE 7)	100 kHz
NOTE 1: For a <i>TAB connector</i> supporting <i>non-contiguous spectrum</i> operation within any operating band, the <i>basic limit</i> within <i>sub-block gaps</i> is calculated as a cumulative sum of contributions from adjacent sub blocks on each side of the <i>sub-block gap</i> . Exception is $\Delta f \geq 10 \text{ MHz}$ from both adjacent sub blocks on each side of the <i>sub-block gap</i> , where the <i>basic limit</i> within <i>sub-block gaps</i> shall be -16dBm/100kHz.			
NOTE 2: For a <i>multi-band TAB connector</i> with <i>Inter RF Bandwidth gap</i> $< 2 \times \Delta f_{\text{OBUe}}$ the <i>basic limit</i> within the <i>Inter RF Bandwidth gaps</i> is calculated as a cumulative sum of contributions from adjacent sub-blocks or <i>Base Station RF Bandwidth</i> on each side of the <i>Inter RF Bandwidth gap</i> .			

For a E-UTRA *TAB connector* operating in Bands 1, 2, 3, 4, 7, 10, 22, 25, 30, 33, 34, 35, 36, 37, 38, 39, 40, 41, 42, 43, 45, 48, 50, 52, 65, 66, 69, 70, 75 emissions shall use the *basic limits* specified in tables 6.6.5.4.3.2-4 to 6.6.5.4.3.2-6:

**Table 6.6.5.4.3.2-4: Wide Area BS operating band unwanted emission limits for 1.4 MHz channel bandwidth (E-UTRA bands >1GHz) for Category B**

Frequency offset of measurement filter -3dB point, $\Delta f$	Frequency offset of measurement filter centre frequency, $f_{\text{offset}}$	<i>basic limit</i> (NOTE 1, 2)	Measurement bandwidth (NOTE 5)
$0 \text{ MHz} \leq \Delta f < 1.4 \text{ MHz}$	$0.05 \text{ MHz} \leq f_{\text{offset}} < 1.45 \text{ MHz}$	$-1\text{dBm} - \frac{10}{1.4} \cdot \left( \frac{f_{\text{offset}}}{\text{MHz}} - 0.05 \right) \text{dB}$	100 kHz
$1.4 \text{ MHz} \leq \Delta f < 2.8 \text{ MHz}$	$1.45 \text{ MHz} \leq f_{\text{offset}} < 2.85 \text{ MHz}$	-11 dBm	100 kHz
$2.8 \text{ MHz} \leq \Delta f \leq \Delta f_{\text{max}}$	$3.3 \text{ MHz} \leq f_{\text{offset}} < f_{\text{offset}_{\text{max}}}$	-15 dBm	1MHz
<p>NOTE 1: For a <i>TAB connector</i> supporting <i>non-contiguous spectrum</i> operation within any operating band, the <i>basic limit</i> within <i>sub-block gaps</i> is calculated as a cumulative sum of contributions from adjacent sub blocks on each side of the <i>sub-block gap</i>, where the contribution from the far-end sub-block shall be scaled according to the measurement bandwidth of the near-end sub-block. Exception is <math>\Delta f \geq 10\text{MHz}</math> from both adjacent sub blocks on each side of the <i>sub-block gap</i>, where the <i>basic limit</i> within <i>sub-block gaps</i> shall be -15dBm/1MHz.</p> <p>NOTE 2: For a <i>multi-band TAB connector</i> with <i>Inter RF Bandwidth gap</i> <math>&lt; 2 \times \Delta f_{\text{OBUE}}</math> the <i>basic limit</i> within the <i>Inter RF Bandwidth gaps</i> is calculated as a cumulative sum of contributions from adjacent sub-blocks or <i>Base Station RF Bandwidth</i> on each side of the <i>Inter RF Bandwidth gap</i>, where the contribution from the far-end sub-block or <i>Base Station RF Bandwidth</i> shall be scaled according to the measurement bandwidth of the near-end sub-block or <i>Base Station RF Bandwidth</i>.</p>			

**Table 6.6.5.4.3.2-5: Wide Area BS operating band unwanted emission limits for 3 MHz channel bandwidth (E-UTRA bands >1GHz) for Category B**

Frequency offset of measurement filter -3dB point, $\Delta f$	Frequency offset of measurement filter centre frequency, $f_{\text{offset}}$	<i>basic limit</i> (NOTE 1, 2)	Measurement bandwidth (NOTE 5)
$0 \text{ MHz} \leq \Delta f < 3 \text{ MHz}$	$0.05 \text{ MHz} \leq f_{\text{offset}} < 3.05 \text{ MHz}$	$-5\text{dBm} - \frac{10}{3} \cdot \left( \frac{f_{\text{offset}}}{\text{MHz}} - 0.05 \right) \text{dB}$	100 kHz
$3 \text{ MHz} \leq \Delta f < 6 \text{ MHz}$	$3.05 \text{ MHz} \leq f_{\text{offset}} < 6.05 \text{ MHz}$	-15 dBm	100 kHz
$6 \text{ MHz} \leq \Delta f \leq \Delta f_{\text{max}}$	$6.5 \text{ MHz} \leq f_{\text{offset}} < f_{\text{offset}_{\text{max}}}$	-15 dBm	1MHz
<p>NOTE 1: For a <i>TAB connector</i> supporting <i>non-contiguous spectrum</i> operation within any operating band, the <i>basic limit</i> within <i>sub-block gaps</i> is calculated as a cumulative sum of contributions from adjacent sub blocks on each side of the <i>sub-block gap</i>, where the contribution from the far-end sub-block shall be scaled according to the measurement bandwidth of the near-end sub-block. Exception is <math>\Delta f \geq 10\text{MHz}</math> from both adjacent sub blocks on each side of the <i>sub-block gap</i>, where the <i>basic limit</i> within <i>sub-block gaps</i> shall be -15dBm/1MHz.</p> <p>NOTE 2: For a <i>multi-band TAB connector</i> with <i>Inter RF Bandwidth gap</i> <math>&lt; 2 \times \Delta f_{\text{OBUE}}</math> the <i>basic limit</i> within the <i>Inter RF Bandwidth gaps</i> is calculated as a cumulative sum of contributions from adjacent sub-blocks or <i>Base Station RF Bandwidth</i> on each side of the <i>Inter RF Bandwidth gap</i>, where the contribution from the far-end sub-block or <i>Base Station RF Bandwidth</i> shall be scaled according to the measurement bandwidth of the near-end sub-block or <i>Base Station RF Bandwidth</i>.</p>			

**Table 6.6.5.4.3.2-6: Wide Area BS operating band unwanted emission limits for 5, 10, 15 and 20 MHz channel bandwidth (E-UTRA bands >1GHz) for Category B**

Frequency offset of measurement filter -3dB point, $\Delta f$	Frequency offset of measurement filter centre frequency, $f_{\text{offset}}$	<i>basic limit</i> (NOTE 1, 2)	Measurement bandwidth (NOTE 5)
$0 \text{ MHz} \leq \Delta f < 5 \text{ MHz}$	$0.05 \text{ MHz} \leq f_{\text{offset}} < 5.05 \text{ MHz}$	$-7 \text{ dBm} - \frac{7}{5} \cdot \left( \frac{f_{\text{offset}}}{\text{MHz}} - 0.05 \right) \text{ dB}$	100 kHz
$5 \text{ MHz} \leq \Delta f < \min(10 \text{ MHz}, \Delta f_{\text{max}})$	$5.05 \text{ MHz} \leq f_{\text{offset}} < \min(10.05 \text{ MHz}, f_{\text{offset}_{\text{max}}})$	-14 dBm	100 kHz
$10 \text{ MHz} \leq \Delta f \leq \Delta f_{\text{max}}$	$10.5 \text{ MHz} \leq f_{\text{offset}} < f_{\text{offset}_{\text{max}}}$	-15 dBm (NOTE 7)	1MHz
NOTE 1: For a <i>TAB connector</i> supporting <i>non-contiguous spectrum</i> operation within any operating band, the <i>basic limit</i> within <i>sub-block gaps</i> is calculated as a cumulative sum of contributions from adjacent sub blocks on each side of the <i>sub-block gap</i> , where the contribution from the far-end sub-block shall be scaled according to the measurement bandwidth of the near-end sub-block. Exception is $\Delta f \geq 10\text{MHz}$ from both adjacent sub blocks on each side of the <i>sub-block gap</i> , where the <i>basic limit</i> within <i>sub-block gaps</i> shall be -15dBm/1MHz.			
NOTE 2: For a <i>multi-band TAB connector</i> with <i>Inter RF Bandwidth gap</i> $< 2 \times \Delta f_{\text{OBUe}}$ the <i>basic limit</i> within the <i>Inter RF Bandwidth gaps</i> is calculated as a cumulative sum of contributions from adjacent sub-blocks or <i>Base Station RF Bandwidth</i> on each side of the <i>Inter RF Bandwidth gap</i> , where the contribution from the far-end sub-block or <i>Base Station RF Bandwidth</i> shall be scaled according to the measurement bandwidth of the near-end sub-block or <i>Base Station RF Bandwidth</i> .			

## 6.6.5.4.3.3 Category B (Option 2)

The *basic limits* in this subclause are intended for Europe and may be applied regionally for a *TAB connector* operating in band 1, 3, 8, 32, 33, 34 or 65.

For a *TAB connector* operating in band 1, 3, 8, 32, 33, 34 or 65, emissions shall use the *basic limits* specified in table 6.6.5.4.3.3-1 below for 5, 10, 15 and 20 MHz *channel bandwidth*:

**Table 6.6.5.4.3.3-1: Regional Wide Area BS operating band unwanted emission limits in band 1, 3, 8, 32, 33, 34 or 65 for 5, 10, 15 and 20 MHz channel bandwidth for Category B**

Frequency offset of measurement filter -3dB point, $\Delta f$	Frequency offset of measurement filter centre frequency, $f_{\text{offset}}$	<i>basic limit</i> (NOTE 1, 2)	Measurement bandwidth (NOTE 5)
$0 \text{ MHz} \leq \Delta f < 0.2 \text{ MHz}$	$0.015\text{MHz} \leq f_{\text{offset}} < 0.215\text{MHz}$	-14 dBm	30 kHz
$0.2 \text{ MHz} \leq \Delta f < 1 \text{ MHz}$	$0.215\text{MHz} \leq f_{\text{offset}} < 1.015\text{MHz}$	$-14\text{dBm} - 15 \cdot \left( \frac{f_{\text{offset}}}{\text{MHz}} - 0.215 \right) \text{ dB}$	30 kHz
(NOTE 6)	$1.015\text{MHz} \leq f_{\text{offset}} < 1.5 \text{ MHz}$	-26 dBm	30 kHz
$1 \text{ MHz} \leq \Delta f \leq \min(10 \text{ MHz}, \Delta f_{\text{max}})$	$1.5 \text{ MHz} \leq f_{\text{offset}} < \min(10.5 \text{ MHz}, f_{\text{offset}_{\text{max}}})$	-13 dBm	1 MHz
$10 \text{ MHz} \leq \Delta f \leq \Delta f_{\text{max}}$	$10.5 \text{ MHz} \leq f_{\text{offset}} < f_{\text{offset}_{\text{max}}}$	-15 dBm (NOTE 7)	1 MHz
NOTE 1: For a <i>TAB connector</i> supporting <i>non-contiguous spectrum</i> operation within any operating band, the <i>basic limit</i> within <i>sub-block gaps</i> is calculated as a cumulative sum of contributions from adjacent sub blocks on each side of the <i>sub-block gap</i> , where the contribution from the far-end sub-block shall be scaled according to the measurement bandwidth of the near-end sub-block. Exception is $\Delta f \geq 10\text{MHz}$ from both adjacent sub blocks on each side of the <i>sub-block gap</i> , where the <i>basic limit</i> within <i>sub-block gaps</i> shall be -15dBm/1MHz.			
NOTE 2: For a <i>multi-band TAB connector</i> with <i>Inter RF Bandwidth gap</i> $< 2 \times \Delta f_{\text{OBUe}}$ the <i>basic limit</i> within the <i>Inter RF Bandwidth gaps</i> is calculated as a cumulative sum of contributions from adjacent sub-blocks or <i>Base Station RF Bandwidth</i> on each side of the <i>Inter RF Bandwidth gap</i> , where the contribution from the far-end sub-block or <i>Base Station RF Bandwidth</i> shall be scaled according to the measurement bandwidth of the near-end sub-block or <i>Base Station RF Bandwidth</i> .			

For a *TAB connector* operating in band 3, 8, or 65 emissions shall use the *basic limits* specified in table 6.6.5.4.3.3-2 below for 3 MHz *channel bandwidth*:

**Table 6.6.5.4.3.3-2: Regional Wide Area BS operating band unwanted emission limits in band 3, 8, or 65 for 3 MHz channel bandwidth for Category B**

Frequency offset of measurement filter -3dB point, $\Delta f$	Frequency offset of measurement filter centre frequency, $f_{\text{offset}}$	<i>basic limit</i> (NOTE 1, 2)	Measurement bandwidth (NOTE 5)
$0 \text{ MHz} \leq \Delta f < 0.05 \text{ MHz}$	$0.015 \text{ MHz} \leq f_{\text{offset}} < 0.065 \text{ MHz}$	$5\text{dBm} - 60 \cdot \left( \frac{f_{\text{offset}}}{\text{MHz}} - 0.015 \right) \text{ dB}$	30 kHz
$0.05 \text{ MHz} \leq \Delta f < 0.15 \text{ MHz}$	$0.065 \text{ MHz} \leq f_{\text{offset}} < 0.165 \text{ MHz}$	$2\text{dBm} - 160 \cdot \left( \frac{f_{\text{offset}}}{\text{MHz}} - 0.065 \right) \text{ dB}$	30 kHz
$0.15 \text{ MHz} \leq \Delta f < 0.2 \text{ MHz}$	$0.165\text{MHz} \leq f_{\text{offset}} < 0.215\text{MHz}$	-14 dBm	30 kHz
$0.2 \text{ MHz} \leq \Delta f < 1 \text{ MHz}$	$0.215\text{MHz} \leq f_{\text{offset}} < 1.015\text{MHz}$	$-14\text{dBm} - 15 \cdot \left( \frac{f_{\text{offset}}}{\text{MHz}} - 0.215 \right) \text{ dB}$	30 kHz
(NOTE 6)	$1.015\text{MHz} \leq f_{\text{offset}} < 1.5 \text{ MHz}$	-26 dBm	30 kHz
$1 \text{ MHz} \leq \Delta f \leq 6 \text{ MHz}$	$1.5 \text{ MHz} \leq f_{\text{offset}} < 6.5 \text{ MHz}$	-13 dBm	1 MHz
$6 \text{ MHz} \leq \Delta f \leq \Delta f_{\text{max}}$	$6.5 \text{ MHz} \leq f_{\text{offset}} < f_{\text{offset}_{\text{max}}}$	-15 dBm	1 MHz
NOTE 1: For a <i>TAB connector</i> supporting <i>non-contiguous spectrum</i> operation within any operating band, the <i>basic limit</i> within <i>sub-block gaps</i> is calculated as a cumulative sum of contributions from adjacent sub blocks on each side of the <i>sub-block gap</i> , where the contribution from the far-end sub-block shall be scaled according to the measurement bandwidth of the near-end sub-block. Exception is $\Delta f \geq 10\text{MHz}$ from both adjacent sub blocks on each side of the <i>sub-block gap</i> , where the <i>basic limit</i> within <i>sub-block gaps</i> shall be -15dBm/1MHz.			
NOTE 2: For a <i>multi-band TAB connector</i> with <i>Inter RF Bandwidth gap</i> $< 2 \times \Delta f_{\text{OBUE}}$ the <i>basic limit</i> within the <i>Inter RF Bandwidth gaps</i> is calculated as a cumulative sum of contributions from adjacent sub-blocks or <i>Base Station RF Bandwidth</i> on each side of the <i>Inter RF Bandwidth gap</i> , where the contribution from the far-end sub-block or <i>Base Station RF Bandwidth</i> shall be scaled according to the measurement bandwidth of the near-end sub-block or <i>Base Station RF Bandwidth</i> .			

For a *TAB connector* operating in band 3, 8 or 65, emissions shall not use the *basic limits* specified in table 6.6.5.4.3.3-3 below for 1.4 MHz channel bandwidth:

**Table 6.6.5.4.3.3-3: Regional Wide Area BS operating band unwanted emission limits in band 3, 8, or 65 for 1.4 MHz channel bandwidth for Category B**

Frequency offset of measurement filter -3dB point, $\Delta f$	Frequency offset of measurement filter centre frequency, $f_{\text{offset}}$	<i>basic limit</i> (NOTE 1, 2)	Measurement bandwidth (NOTE 5)
$0 \text{ MHz} \leq \Delta f < 0.05 \text{ MHz}$	$0.015 \text{ MHz} \leq f_{\text{offset}} < 0.065 \text{ MHz}$	$5\text{dBm} - 60 \cdot \left( \frac{f_{\text{offset}}}{\text{MHz}} - 0.015 \right) \text{ dB}$	30 kHz
$0.05 \text{ MHz} \leq \Delta f < 0.15 \text{ MHz}$	$0.065 \text{ MHz} \leq f_{\text{offset}} < 0.165 \text{ MHz}$	$2\text{dBm} - 160 \cdot \left( \frac{f_{\text{offset}}}{\text{MHz}} - 0.065 \right) \text{ dB}$	30 kHz
$0.15 \text{ MHz} \leq \Delta f < 0.2 \text{ MHz}$	$0.165\text{MHz} \leq f_{\text{offset}} < 0.215\text{MHz}$	-14 dBm	30 kHz
$0.2 \text{ MHz} \leq \Delta f < 1 \text{ MHz}$	$0.215\text{MHz} \leq f_{\text{offset}} < 1.015\text{MHz}$	$-14\text{dBm} - 15 \cdot \left( \frac{f_{\text{offset}}}{\text{MHz}} - 0.215 \right) \text{ dB}$	30 kHz
(NOTE 6)	$1.015\text{MHz} \leq f_{\text{offset}} < 1.5 \text{ MHz}$	-26 dBm	30 kHz
$1 \text{ MHz} \leq \Delta f \leq 2.8 \text{ MHz}$	$1.5 \text{ MHz} \leq f_{\text{offset}} < 3.3 \text{ MHz}$	-13 dBm	1 MHz
$2.8 \text{ MHz} \leq \Delta f \leq \Delta f_{\text{max}}$	$3.3 \text{ MHz} \leq f_{\text{offset}} < f_{\text{offset}_{\text{max}}}$	-15 dBm	1 MHz
NOTE 1: For a <i>TAB connector</i> supporting <i>non-contiguous spectrum</i> operation within any operating band, the <i>basic limit</i> within <i>sub-block gaps</i> is calculated as a cumulative sum of contributions from adjacent sub blocks on each side of the <i>sub-block gap</i> , where the contribution from the far-end sub-block shall be scaled according to the measurement bandwidth of the near-end sub-block. Exception is $\Delta f \geq 10\text{MHz}$ from both adjacent sub blocks on each side of the <i>sub-block gap</i> , where the <i>basic limit</i> within <i>sub-block gaps</i> shall be -15dBm/1MHz.			
NOTE 2: For a <i>multi-band TAB connector</i> with <i>Inter RF Bandwidth gap</i> $< 2 \times \Delta f_{\text{OBUE}}$ the <i>basic limit</i> within the <i>Inter RF Bandwidth gaps</i> is calculated as a cumulative sum of contributions from adjacent sub-blocks or <i>Base Station RF Bandwidth</i> on each side of the <i>Inter RF Bandwidth gap</i> , where the contribution from the far-end sub-block or <i>Base Station RF Bandwidth</i> shall be scaled according to the measurement bandwidth of the near-end sub-block or <i>Base Station RF Bandwidth</i> .			

## 6.6.5.4.4 Basic limits for Local Area BS (Category A and B)

For Local Area BS, *basic limits* are specified in tables 6.6.5.4.4-1 to 6.6.5.4.4-3.

**Table 6.6.5.4.4-1: Local Area BS operating band unwanted emission limits for 1.4 MHz channel bandwidth**

Frequency offset of measurement filter -3dB point, $\Delta f$	Frequency offset of measurement filter centre frequency, $f_{\text{offset}}$	<i>basic limit</i> (NOTE 1, 2)	Measurement bandwidth (NOTE 5)
$0 \text{ MHz} \leq \Delta f < 1.4 \text{ MHz}$	$0.05 \text{ MHz} \leq f_{\text{offset}} < 1.45 \text{ MHz}$	$-21 \text{ dBm} - \frac{10}{1.4} \left( \frac{f_{\text{offset}}}{\text{MHz}} - 0.05 \right) \text{ dB}$	100 kHz
$1.4 \text{ MHz} \leq \Delta f < 2.8 \text{ MHz}$	$1.45 \text{ MHz} \leq f_{\text{offset}} < 2.85 \text{ MHz}$	-31 dBm	100 kHz
$2.8 \text{ MHz} \leq \Delta f \leq \Delta f_{\text{max}}$	$2.85 \text{ MHz} \leq f_{\text{offset}} < f_{\text{offset}_{\text{max}}}$	-31 dBm	100 kHz

NOTE 1: For a *TAB connector* supporting *non-contiguous spectrum* operation within any operating band the *basic limit* within *sub-block gaps* is calculated as a cumulative sum of contributions from adjacent sub blocks on each side of the *sub-block gap*. Exception is  $\Delta f \geq 10 \text{ MHz}$  from both adjacent sub blocks on each side of the *sub-block gap*, where the *basic limit* within *sub-block gaps* shall be -31 dBm/100kHz.

NOTE 2: For a *multi-band TAB connector* with *Inter RF Bandwidth gap*  $< 2 \times \Delta f_{\text{OBUE}}$  the *basic limit* within the *Inter RF Bandwidth gaps* is calculated as a cumulative sum of contributions from adjacent sub-blocks or *Base Station RF Bandwidth* on each side of the *Inter RF Bandwidth gap*.

**Table 6.6.5.4.4-2: Local Area BS operating band unwanted emission limits for 3 MHz channel bandwidth**

Frequency offset of measurement filter -3dB point, $\Delta f$	Frequency offset of measurement filter centre frequency, $f_{\text{offset}}$	<i>basic limit</i> (NOTE 1, 2)	Measurement bandwidth (NOTE 5)
$0 \text{ MHz} \leq \Delta f < 3 \text{ MHz}$	$0.05 \text{ MHz} \leq f_{\text{offset}} < 3.05 \text{ MHz}$	$-25 \text{ dBm} - \frac{10}{3} \left( \frac{f_{\text{offset}}}{\text{MHz}} - 0.05 \right) \text{ dB}$	100 kHz
$3 \text{ MHz} \leq \Delta f < 6 \text{ MHz}$	$3.05 \text{ MHz} \leq f_{\text{offset}} < 6.05 \text{ MHz}$	-35 dBm	100 kHz
$6 \text{ MHz} \leq \Delta f \leq \Delta f_{\text{max}}$	$6.05 \text{ MHz} \leq f_{\text{offset}} < f_{\text{offset}_{\text{max}}}$	-35 dBm	100 kHz

NOTE 1: For a *TAB connector* supporting *non-contiguous spectrum* operation within any operating band the *basic limit* within *sub-block gaps* is calculated as a cumulative sum of contributions from adjacent sub blocks on each side of the *sub-block gap*. Exception is  $\Delta f \geq 10 \text{ MHz}$  from both adjacent sub blocks on each side of the *sub-block gap*, where the *basic limit* within *sub-block gaps* shall be -35 dBm/100kHz.

NOTE 2: For a *multi-band TAB connector* with *Inter RF Bandwidth gap*  $< 2 \times \Delta f_{\text{OBUE}}$  the *basic limit* within the *Inter RF Bandwidth gaps* is calculated as a cumulative sum of contributions from adjacent sub-blocks or *Base Station RF Bandwidth* on each side of the *Inter RF Bandwidth gap*.

**Table 6.6.5.4.4-3: Local Area BS operating band unwanted emission limits for 5, 10, 15 and 20 MHz channel bandwidth**

Frequency offset of measurement filter -3dB point, $\Delta f$	Frequency offset of measurement filter centre frequency, $f_{\text{offset}}$	<i>basic limit</i> (NOTE 1, 2)]	Measurement bandwidth (NOTE 5)
$0 \text{ MHz} \leq \Delta f < 5 \text{ MHz}$	$0.05 \text{ MHz} \leq f_{\text{offset}} < 5.05 \text{ MHz}$	$-30 \text{ dBm} - \frac{7}{5} \left( \frac{f_{\text{offset}}}{\text{MHz}} - 0.05 \right) \text{ dB}$	100 kHz
$5 \text{ MHz} \leq \Delta f < \min(10 \text{ MHz}, \Delta f_{\text{max}})$	$5.05 \text{ MHz} \leq f_{\text{offset}} < \min(10.05 \text{ MHz}, f_{\text{offset}_{\text{max}}})$	-37 dBm	100 kHz
$10 \text{ MHz} \leq \Delta f \leq \Delta f_{\text{max}}$	$10.05 \text{ MHz} \leq f_{\text{offset}} < f_{\text{offset}_{\text{max}}}$	-37 dBm (NOTE 7)	100 kHz

NOTE 1: For a *TAB connector* supporting *non-contiguous spectrum* operation within any operating band the *basic limit* within *sub-block gaps* is calculated as a cumulative sum of contributions from adjacent sub blocks on each side of the *sub-block gap*. Exception is  $\Delta f \geq 10 \text{ MHz}$  from both adjacent sub blocks on each side of the *sub-block gap*, where the *basic limit* within *sub-block gaps* shall be -37 dBm/100kHz.

NOTE 2: For a *multi-band TAB connector* with *Inter RF Bandwidth gap*  $< 2 \times \Delta f_{\text{OBUE}}$  the *basic limit* within the *Inter RF Bandwidth gaps* is calculated as a cumulative sum of contributions from adjacent sub-blocks or *Base Station RF Bandwidth* on each side of the *Inter RF Bandwidth gap*.

## 6.6.5.4.5 Basic limits for Medium Range BS (Category A and B)

For Medium Range BS, *basic limits* are specified in tables 6.6.5.4.5-1 to 6.6.5.4.5-6.

**Table 6.6.5.4.5-1: Medium Range BS operating band unwanted emission limits for 1.4 MHz channel bandwidth,  $31 < P_{\text{rated,c,cell}} - 10 \cdot \log_{10}(N_{\text{TXU,countedpercell}}) \leq 38$  dBm**

Frequency offset of measurement filter -3dB point, $\Delta f$	Frequency offset of measurement filter centre frequency, $f_{\text{offset}}$	<i>basic limit</i> (NOTE 1, 2)	Measurement bandwidth (NOTE 5)
$0 \text{ MHz} \leq \Delta f < 1.4 \text{ MHz}$	$0.05 \text{ MHz} \leq f_{\text{offset}} < 1.45 \text{ MHz}$	$P_{\text{rated,c,cell}} - 10 \cdot \log_{10}(N_{\text{TXU,countedpercell}}) - 45 \text{ dB} - (10/1,4) \cdot (f_{\text{offset}}/\text{MHz} - 0,05) \text{ dB}$	100 kHz
$1.4 \text{ MHz} \leq \Delta f < 2.8 \text{ MHz}$	$1.45 \text{ MHz} \leq f_{\text{offset}} < 2.85 \text{ MHz}$	$P_{\text{rated,c,cell}} - 10 \cdot \log_{10}(N_{\text{TXU,countedpercell}}) - 55 \text{ dB}$	100 kHz
$2.8 \text{ MHz} \leq \Delta f \leq \Delta f_{\text{max}}$	$2.85 \text{ MHz} \leq f_{\text{offset}} < f_{\text{offset}_{\text{max}}}$	-25dBm	100 kHz

NOTE 1: For a *TAB connector* supporting *non-contiguous spectrum* operation within any operating band the *basic limit* within *sub-block gaps* is calculated as a cumulative sum of contributions from adjacent sub blocks on each side of the *sub-block gap*. Exception is  $\Delta f \geq 10 \text{ MHz}$  from both adjacent sub blocks on each side of the *sub-block gap*, where the *basic limit* within *sub-block gaps* shall be -25dBm/100kHz.

NOTE 2: For a *multi-band TAB connector* with *Inter RF Bandwidth gap*  $< 2 \times \Delta f_{\text{OBUE}}$  the *basic limit* within the *Inter RF Bandwidth gaps* is calculated as a cumulative sum of contributions from adjacent sub-blocks or *Base Station RF Bandwidth* on each side of the *Inter RF Bandwidth gap*.

**Table 6.6.5.4.5-2: Medium Range BS operating band unwanted emission limits for 1.4 MHz channel bandwidth,  $P_{\text{rated,c,cell}} - 10 \cdot \log_{10}(N_{\text{TXU,countedpercell}}) \leq 31$  dBm**

Frequency offset of measurement filter -3dB point, $\Delta f$	Frequency offset of measurement filter centre frequency, $f_{\text{offset}}$	<i>basic limit</i> (NOTE 1, 2)	Measurement bandwidth (NOTE 5)
$0 \text{ MHz} \leq \Delta f < 1.4 \text{ MHz}$	$0.05 \text{ MHz} \leq f_{\text{offset}} < 1.45 \text{ MHz}$	$-14 \text{ dBm} - \frac{10}{1.4} \left( \frac{f_{\text{offset}}}{\text{MHz}} - 0.05 \right) \text{ dB}$	100 kHz
$1.4 \text{ MHz} \leq \Delta f < 2.8 \text{ MHz}$	$1.45 \text{ MHz} \leq f_{\text{offset}} < 2.85 \text{ MHz}$	-24 dBm	100 kHz
$2.8 \text{ MHz} \leq \Delta f \leq \Delta f_{\text{max}}$	$2.85 \text{ MHz} \leq f_{\text{offset}} < f_{\text{offset}_{\text{max}}}$	-25dBm	100 kHz

NOTE 1: For a *TAB connector* supporting *non-contiguous spectrum* operation within any operating band the *basic limit* within *sub-block gaps* is calculated as a cumulative sum of contributions from adjacent sub blocks on each side of the *sub-block gap*. Exception is  $\Delta f \geq 10 \text{ MHz}$  from both adjacent sub blocks on each side of the *sub-block gap*, where the *basic limit* within *sub-block gaps* shall be -25dBm/100kHz.

NOTE 2: For a *multi-band TAB connector* with *Inter RF Bandwidth gap*  $< 2 \times \Delta f_{\text{OBUE}}$  the *basic limit* within the *Inter RF Bandwidth gaps* is calculated as a cumulative sum of contributions from adjacent sub-blocks or *Base Station RF Bandwidth* on each side of the *Inter RF Bandwidth gap*.

**Table 6.6.5.4.5-3: Medium Range BS operating band unwanted emission limits for 3 MHz channel bandwidth,  $31 < P_{\text{rated,c,cell}} - 10 \cdot \log_{10}(N_{\text{TXU,countedpercell}}) \leq 38$  dBm**

Frequency offset of measurement filter -3dB point, $\Delta f$	Frequency offset of measurement filter centre frequency, $f_{\text{offset}}$	<i>basic limit</i> (NOTE 1, 2)	Measurement bandwidth (NOTE 5)
$0 \text{ MHz} \leq \Delta f < 3 \text{ MHz}$	$0.05 \text{ MHz} \leq f_{\text{offset}} < 3.05 \text{ MHz}$	$P_{\text{rated,c,cell}} - 10 \cdot \log_{10}(N_{\text{TXU,countedpercell}}) - 49\text{dB} - (10/3) \cdot (f_{\text{offset}}/\text{MHz} - 0,05)\text{dB}$	100 kHz
$3 \text{ MHz} \leq \Delta f < 6 \text{ MHz}$	$3.05 \text{ MHz} \leq f_{\text{offset}} < 6.05 \text{ MHz}$	$P_{\text{rated,c,cell}} - 10 \cdot \log_{10}(N_{\text{TXU,countedpercell}}) - 59\text{dB}$	100 kHz
$6 \text{ MHz} \leq \Delta f \leq \Delta f_{\text{max}}$	$6.05 \text{ MHz} \leq f_{\text{offset}} < f_{\text{offset}_{\text{max}}}$	$\text{Min}(P_{\text{rated,c,cell}} - 10 \cdot \log_{10}(N_{\text{TXU,countedpercell}}) - 59\text{dB}, -25\text{dBm})$	100 kHz
NOTE 1: For a <i>TAB connector</i> supporting <i>non-contiguous spectrum</i> operation within any operating band the <i>basic limit</i> within <i>sub-block gaps</i> is calculated as a cumulative sum of contributions from adjacent sub blocks on each side of the <i>sub-block gap</i> . Exception is $\Delta f \geq 10\text{MHz}$ from both adjacent sub blocks on each side of the <i>sub-block gap</i> , where the <i>basic limit</i> within <i>sub-block gaps</i> shall be $\text{Min}(P_{\text{rated,c,cell}} - 10 \cdot \log_{10}(N_{\text{TXU,countedpercell}}) - 59\text{dB}, -25\text{dBm})/100\text{kHz}$ .			
NOTE 2: For a <i>multi-band TAB connector</i> with <i>Inter RF Bandwidth gap</i> $< 2 \times \Delta f_{\text{OBUE}}$ the <i>basic limit</i> within the <i>Inter RF Bandwidth gaps</i> is calculated as a cumulative sum of contributions from adjacent sub-blocks or <i>Base Station RF Bandwidth</i> on each side of the <i>Inter RF Bandwidth gap</i> .			

**Table 6.6.5.4.5-4: Medium Range BS operating band unwanted emission limits for 3 MHz channel bandwidth,  $P_{\text{rated,c,cell}} - 10 \cdot \log_{10}(N_{\text{TXU,countedpercell}}) \leq 31$  dBm**

Frequency offset of measurement filter -3dB point, $\Delta f$	Frequency offset of measurement filter centre frequency, $f_{\text{offset}}$	<i>basic limit</i> (NOTE 1, 2)	Measurement bandwidth (NOTE 5)
$0 \text{ MHz} \leq \Delta f < 3 \text{ MHz}$	$0.05 \text{ MHz} \leq f_{\text{offset}} < 3.05 \text{ MHz}$	$-18\text{dBm} - \frac{10}{3} \left( \frac{f_{\text{offset}}}{\text{MHz}} - 0,05 \right) \text{dB}$	100 kHz
$3 \text{ MHz} \leq \Delta f < 6 \text{ MHz}$	$3.05 \text{ MHz} \leq f_{\text{offset}} < 6.05 \text{ MHz}$	-28 dBm	100 kHz
$6 \text{ MHz} \leq \Delta f \leq \Delta f_{\text{max}}$	$6.05 \text{ MHz} \leq f_{\text{offset}} < f_{\text{offset}_{\text{max}}}$	-28 dBm	100 kHz
NOTE 1: For a <i>TAB connector</i> supporting <i>non-contiguous spectrum</i> operation within any operating band the <i>basic limit</i> within <i>sub-block gaps</i> is calculated as a cumulative sum of contributions from adjacent sub blocks on each side of the <i>sub-block gap</i> . Exception is $\Delta f \geq 10\text{MHz}$ from both adjacent sub blocks on each side of the <i>sub-block gap</i> , where the <i>basic limit</i> within <i>sub-block gaps</i> shall be $-28\text{dBm}/100\text{kHz}$ .			
NOTE 2: For a <i>multi-band TAB connector</i> with <i>Inter RF Bandwidth gap</i> $< 2 \times \Delta f_{\text{OBUE}}$ the <i>basic limit</i> within the <i>Inter RF Bandwidth gaps</i> is calculated as a cumulative sum of contributions from adjacent sub-blocks or <i>Base Station RF Bandwidth</i> on each side of the <i>Inter RF Bandwidth gap</i> .			

**Table 6.6.5.4.5-5: Medium Range BS operating band unwanted emission limits for 5, 10, 15 and 20 MHz channel bandwidth,  $31 < P_{\text{rated,c,cell}} - 10 \cdot \log_{10}(N_{\text{TXU,countedpercell}}) \leq 38$  dBm**

Frequency offset of measurement filter -3dB point, $\Delta f$	Frequency offset of measurement filter centre frequency, $f_{\text{offset}}$	<i>basic limit</i> (NOTE 1, 2)	Measurement bandwidth (NOTE 5)
$0 \text{ MHz} \leq \Delta f < 5 \text{ MHz}$	$0.05 \text{ MHz} \leq f_{\text{offset}} < 5.05 \text{ MHz}$	$P_{\text{rated,c,cell}} - 10 \cdot \log_{10}(N_{\text{TXU,countedpercell}}) - 53\text{dB} - (7/5) \cdot (f_{\text{offset}}/\text{MHz} - 0,05)\text{dB}$	100 kHz
$5 \text{ MHz} \leq \Delta f < \min(10 \text{ MHz}, \Delta f_{\text{max}})$	$5.05 \text{ MHz} \leq f_{\text{offset}} < \min(10.05 \text{ MHz}, f_{\text{offset}_{\text{max}}})$	$P_{\text{rated,c,cell}} - 10 \cdot \log_{10}(N_{\text{TXU,countedpercell}}) - 60\text{dB}$	100 kHz
$10 \text{ MHz} \leq \Delta f \leq \Delta f_{\text{max}}$	$10.05 \text{ MHz} \leq f_{\text{offset}} < f_{\text{offset}_{\text{max}}}$	$\text{Min}(P_{\text{rated,c,cell}} - 10 \cdot \log_{10}(N_{\text{TXU,countedpercell}}) - 60\text{dB}, -25\text{dBm})$ (NOTE 6)	100 kHz
NOTE 1: For a <i>TAB connector</i> supporting <i>non-contiguous spectrum</i> operation within any operating band the <i>basic limit</i> within <i>sub-block gaps</i> is calculated as a cumulative sum of contributions from adjacent sub blocks on each side of the <i>sub-block gap</i> . Exception is $\Delta f \geq 10\text{MHz}$ from both adjacent sub blocks on each side of the <i>sub-block gap</i> , where the <i>basic limit</i> within <i>sub-block gaps</i> shall be $\text{Min}(P_{\text{rated,c,cell}} - 10 \cdot \log_{10}(N_{\text{TXU,countedpercell}}) - 60\text{dB}, -25\text{dBm})/100\text{kHz}$ .			
NOTE 2: For a <i>multi-band TAB connector</i> with <i>Inter RF Bandwidth gap</i> $< 2 \times \Delta f_{\text{OBUE}}$ the <i>basic limit</i> within the <i>Inter RF Bandwidth gaps</i> is calculated as a cumulative sum of contributions from adjacent sub-blocks or <i>Base Station RF Bandwidth</i> on each side of the <i>Inter RF Bandwidth gap</i> .			

**Table 6.6.5.4.5-6: Medium Range BS operating band unwanted emission limits for 5, 10, 15 and 20 MHz channel bandwidth,  $P_{\text{rated,c,cell}} - 10 \cdot \log_{10}(N_{\text{TXU,countedpercell}}) \leq 31$  dBm**

Frequency offset of measurement filter -3dB point, $\Delta f$	Frequency offset of measurement filter centre frequency, $f_{\text{offset}}$	<i>basic limit</i> (NOTE 1, 2)	Measurement bandwidth (NOTE 5)
$0 \text{ MHz} \leq \Delta f < 5 \text{ MHz}$	$0.05 \text{ MHz} \leq f_{\text{offset}} < 5.05 \text{ MHz}$	$-22 \text{ dBm} - \frac{7}{5} \left( \frac{f_{\text{offset}}}{\text{MHz}} - 0.05 \right) \text{ dB}$	100 kHz
$5 \text{ MHz} \leq \Delta f < \min(10 \text{ MHz}, \Delta f_{\text{max}})$	$5.05 \text{ MHz} \leq f_{\text{offset}} < \min(10.05 \text{ MHz}, f_{\text{offset}_{\text{max}}})$	-29 dBm	100 kHz
$10 \text{ MHz} \leq \Delta f \leq \Delta f_{\text{max}}$	$10.05 \text{ MHz} \leq f_{\text{offset}} < f_{\text{offset}_{\text{max}}}$	-29 dBm (NOTE 6)	100 kHz
NOTE 1: For a <i>TAB connector</i> supporting <i>non-contiguous spectrum</i> operation within any operating band the <i>basic limit</i> within <i>sub-block gaps</i> is calculated as a cumulative sum of contributions from adjacent sub blocks on each side of the <i>sub-block gap</i> . Exception is $\Delta f \geq 10 \text{ MHz}$ from both adjacent sub blocks on each side of the <i>sub-block gap</i> , where the <i>basic limit</i> within <i>sub-block gaps</i> shall be -29dBm/100kHz. NOTE 2: For a <i>multi-band TAB connector</i> with <i>Inter RF Bandwidth gap</i> $< 2 \times \Delta f_{\text{OBUE}}$ the <i>basic limit</i> within the <i>Inter RF Bandwidth gaps</i> is calculated as a cumulative sum of contributions from adjacent sub-blocks or <i>Base Station RF Bandwidth</i> on each side of the <i>Inter RF Bandwidth gap</i> .			

#### 6.6.5.4.6 Void

#### 6.6.5.4.7 Additional requirements

The E-UTRA operating band unwanted emission *basic limits* for additional requirements are the same as the *basic limit* is specified in 3GPP TS 36.104 [8], subclause 6.6.3.3.

Additional requirements specified in TS 36.104 [8], subclause 6.6.3.3 for Band 41 and Band 49 are not applicable for AAS BS.

### 6.6.6 Spurious emission

#### 6.6.6.1 General

The conducted transmitter spurious emission limits apply from 9 kHz to 12.75 GHz, excluding the following RAT-specific frequency ranges:

- UTRA TDD BS, 1.28 Mcps option as specified in TS 25.105 [3]: from 4 MHz below the lowest frequency of each operating band to 4 MHz above the highest frequency of each operating band.
- UTRA FDD BS as specified in TS 25.104 [2]: from 12.5MHz below the lowest carrier frequency used up to 12.5MHz above the highest carrier frequency used.
- E-UTRA BS as specified in TS 36.104 [4]: from  $\Delta f_{\text{OBUE}}$  below the lowest frequency of the *downlink operating band* up to  $\Delta f_{\text{OBUE}}$  above the highest frequency of the *downlink operating band*, where  $\Delta f_{\text{OBUE}}$  is defined subclause 6.6.1.
- MSR BS as specified in TS 37.104 [5]: from  $\Delta f_{\text{OBUE}}$  below the lowest frequency of the *downlink operating band* up to  $\Delta f_{\text{OBUE}}$  above the highest frequency of the *downlink operating band*, where  $\Delta f_{\text{OBUE}}$  is defined subclause 6.6.1.

For some operating bands the upper frequency limit is higher than 12.75 GHz in order to comply with the 5<sup>th</sup> harmonic limit of the *downlink operating band*, as specified in ITU-R recommendation SM.329 [14]. In some exceptional cases, requirements apply also closer than  $\Delta f_{\text{OBUE}}$  MHz from the *downlink operating band*; these cases are highlighted in the requirement tables in respective referenced UTRA, E-UTRA or MSR specifications. For operating bands supported by *multi-band TAB connectors* exclusion bands apply to each supported band.

The requirements apply for both *single band TAB connectors* and *multi-band TAB connectors* (except for frequencies at which exclusion bands or other multi-band provisions apply) and for all transmission modes foreseen by the manufacturer's specification. Unless otherwise stated, all requirements are measured as mean power.

For operation in Region 2, where the FCC guidance for MIMO systems in [18] is applicable,  $N_{\text{TXU, countedpercell}}$  shall be equal to 1 for the purposes of calculating the spurious emissions limits in subclauses 6.6.6.2, 6.6.6.3 or 6.6.6.4. For all other unwanted emissions requirements,  $N_{\text{TXU, countedpercell}}$  shall be the value calculated according to subclause 6.1, unless stated differently in regional regulation.

The AAS BS requirements for spurious emissions limits which are specified for Band 46 or Band 49 in 3GPP TS 37.104 [5], are applicable for AAS BS.

### 6.6.6.2 Minimum requirement for MSR operation

The MSR spurious emission *basic limits* are the same as those specified in 3GPP TS 37.104 [9], subclauses 6.6.1.1, 6.6.1.2, 6.6.1.3 and 6.6.1.4.

The spurious emission requirements for an MSR AAS BS are that for each *TAB connector TX mincell group* and each applicable *basic limit* as specified in 3GPP TS 37.104 [5], the power summation emissions at the *TAB connectors* of the *TAB connector TX min cell group* shall not exceed an AAS limit specified as the *basic limit* + X, where  $X = 10\log_{10}(N_{\text{TXU, countedpercell}})$ , unless stated differently in regional regulation.

NOTE: Conformance to the AAS BS spurious emission requirement can be demonstrated by meeting at least one of the following criteria as determined by the manufacturer:

- 1) The sum of the emissions power measured on each *TAB connector* in the *TAB connector TX min cell group* shall be less than or equal to the AAS BS limit as defined in this subclause for the respective frequency span.

Or

- 2) The unwanted emissions power at each *TAB connector* shall be less than or equal to the AAS BS limit as defined in this subclause for the respective frequency span, scaled by  $-10\log_{10}(n)$ , where  $n$  is the number of *TAB connectors* in the *TAB connector TX min cell group*.

### 6.6.6.3 Minimum requirement for single RAT UTRA operation

The single RAT UTRA FDD spurious emission *basic limits* are the same as those specified in 3GPP TS 25.104 [6], subclauses 6.6.3.1-6.6.3.8.

The single RAT UTRA TDD spurious emission *basic limits* are the same as those specified in 3GPP TS 25.105 [7], subclauses 6.6.3.1-6.6.3.5.

The spurious emission requirements for a UTRA single RAT AAS BS are that for each *TAB connector TX min cell group* and each applicable *basic limit* as specified in 3GPP TS 25.104 [6] or 3GPP TS 25.105 [7], the power sum of the emissions at the *TAB connectors* associated with the *TAB connector TX min cell group* shall not exceed an AAS limit specified as the *basic limit* + X, where  $X = 10\log_{10}(N_{\text{TXU, countedpercell}})$ , unless stated differently in regional regulation.

NOTE: Conformance to the AAS BS spurious emission requirement can be demonstrated by meeting at least one of the following criteria as determined by the manufacturer:

- 1) The sum of the emissions power measured on each *TAB connector* in the *TAB connector TX min cell group* shall be less than or equal to the AAS BS limit as defined in this subclause for the respective frequency span.

Or

- 2) The unwanted emissions power at each *TAB connector* shall be less than or equal to the AAS BS limit as defined in this subclause for the respective frequency span, scaled by  $-10\log_{10}(n)$ , where  $n$  is the number of *TAB connectors* in the *TAB connector TX min cell group*.

#### 6.6.6.4 Minimum requirement for single RAT E-UTRA operation

*Single RAT E-UTRA operation* spurious emission *basic limits* are the same as those specified in 3GPP TS 36.104 [8], subclauses 6.6.4.1-6.6.4.4. Spurious emission limits specified in TS 36.104 [8], subclauses 6.6.4.1-6.6.4.4 for Band 41, Band 46 and Band 49 are not applicable for AAS BS.

The spurious emission requirements for AAS BS in *single RAT E-UTRA operation* are that for each *TAB connector TX min cell group* and for each applicable *basic limit* as specified in 3GPP TS 36.104 [4], the total emissions at the *TAB connectors* associated with the *TAB connector TX min cell group* shall not exceed an AAS limit specified as the *basic limit* + X, where  $X = 10\log_{10}(N_{\text{TXU, counted per cell}})$ , unless stated differently in regional regulation.

NOTE: Conformance to the AAS BS spurious emission requirement can be demonstrated by meeting at least one of the following criteria as determined by the manufacturer:

- 1) The sum of the emissions power measured on each *TAB connector* in the *TAB connector TX min cell group* shall be less than or equal to the AAS BS limit as defined in this subclause for the respective frequency span.

Or

- 2) The unwanted emissions power at each *TAB connector* shall be less than or equal to the AAS BS limit as defined in this subclause for the respective frequency span, scaled by  $-10\log_{10}(n)$ , where  $n$  is the number of *TAB connectors* in the *TAB connector TX min cell group*.

## 6.7 Transmitter intermodulation

### 6.7.1 General

The transmitter intermodulation requirement is a measure of the capability of the transmitter unit to inhibit the generation of signals in its non-linear elements caused by presence of the wanted signal and an interfering signal reaching the transmitter unit via the RDN and antenna array. The requirement applies during the *transmitter ON period* and the *transmitter transient period*.

The requirement applies at each *TAB connector* supporting transmission in the operating band.

The transmitter intermodulation level is the power of the intermodulation products when an interfering signal is injected into the *TAB connector*.

For AAS BS there are two types of transmitter intermodulation cases captured by the transmitter intermodulation requirement:

- 1) Co-location transmitter intermodulation in which the interfering signal is from a co-located base station.
- 2) Intra-system transmitter intermodulation in which the interfering signal is from other transmitter units within the AAS BS.

For AAS BS, the co-location transmitter intermodulation requirement is considered sufficient if the interfering signal for the co-location requirement is higher than the declared interfering signal for intra-system transmitter intermodulation requirement.

### 6.7.2 Minimum requirement for MSR operation

#### 6.7.2.1 General co-location minimum requirement

The transmitter intermodulation level shall not exceed the unwanted emission limits specified for transmitter spurious emission in subclause 6.6.6, operating band unwanted emission in subclause 6.6.5 and ACLR in subclause 6.6.3 in the presence of a wanted signal and an interfering signal according to table 6.7.2.1-1 for AAS BS operation in BC1, BC2 and BC3.

The requirement is applicable outside the *Base Station RF Bandwidth edges*. The interfering signal offset is defined relative to the *Base Station RF Bandwidth edges* or *Radio Bandwidth edges*.

For *TAB connectors* supporting operation in *non-contiguous spectrum*, the requirement is also applicable inside a *sub-block gap* for interfering signal offsets where the interfering signal falls completely within the *sub-block gap*. The interfering signal offset is defined relative to the *sub-block* edges.

For *TAB connectors* supporting operation in multiple operating bands, the requirement applies relative to the *Base Station RF Bandwidth edges* of each operating band. In case the inter *Base Station RF Bandwidth* gap is less than 15 MHz, the requirement in the gap applies only for interfering signal offsets where the interfering signal falls completely within the inter *Base Station RF Bandwidth* gap.

**Table 6.7.2.1-1: Interfering signal for the co-location transmitter intermodulation requirement**

Parameter	Value
Wanted signal type	E-UTRA or NR signal
Interfering signal type	E-UTRA signal of <i>channel bandwidth</i> 5 MHz
Interfering signal level	<i>Rated total output power per TAB connector</i> in the operating band ( $P_{\text{Rated,t,TABC}} - 30\text{dB}$ )
Interfering signal centre frequency offset from <i>Base Station RF Bandwidth</i> edge or edge of <i>sub-block</i> inside a gap	$\pm 2.5$ MHz $\pm 7.5$ MHz $\pm 12.5$ MHz
NOTE 1: Interfering signal positions that are partially or completely outside of any <i>downlink operating band</i> of the <i>TAB connector</i> are excluded from the requirement, unless the interfering signal positions fall within the frequency range of adjacent <i>downlink operating bands</i> in the same geographical area. In case that none of the interfering signal positions fall completely within the frequency range of the <i>downlink operating band</i> , 3GPP TS 37.141 [19] provides further guidance regarding appropriate test requirements.	
NOTE 2: In certain regions, NOTE 1 is not applied in Band 1, 3, 8, 9, 11, 18, 19, 21, 28, 32 operating within 1 475.9 MHz to 1 495.9 MHz, 34.	

### 6.7.2.2 Additional co-location minimum requirement (BC1 and BC2)

The transmitter intermodulation level shall not exceed the unwanted emission limits specified for transmitter spurious emission in subclause 6.6.6, operating band unwanted emission in subclause 6.6.5 and ACLR in subclause 6.6.3 in the presence of a wanted signal and an interfering signal according to table 6.7.2.2-1 for BS operation in BC2.

The requirement is applicable outside the *Base Station RF Bandwidth* edges for BC2. The interfering signal offset is defined relative to the *Base Station RF Bandwidth* edges.

For *TAB connectors* supporting operation in *non-contiguous spectrum* in BC1 or BC2, the requirement is also applicable inside a *sub-block gap* with a gap size larger than or equal to two times the interfering signal centre frequency offset. For *TAB connectors* supporting operation in *non-contiguous spectrum* in BC1, the requirement is not applicable inside a *sub-block gap* with a gap size equal to or larger than 5 MHz. The interfering signal offset is defined relative to the *sub-block* edges.

For *TAB connectors* supporting operation in multiple operating bands, the requirement applies relative to the *Base Station RF Bandwidth edges* of a BC2 operating band. The requirement is also applicable for BC1 and BC2 inside an inter *Base Station RF Bandwidth* gap equal to or larger than two times the interfering signal centre frequency offset. For *TAB connectors* supporting operation in multiple operating bands, the requirement is not applicable for BC1 band inside an inter *Base Station RF Bandwidth* gap with a gap size equal to or larger than 5 MHz.

**Table 6.7.2.2-1: Interfering signal for the co-location transmitter intermodulation requirement**

Parameter	Value
Wanted signal type	E-UTRA or NR or UTRA signal
Interfering signal type	CW
Interfering signal level	<i>Rated total output power per TAB connector</i> in the operating band ( $P_{\text{Rated,t,TABC}} - 30\text{dB}$ )
Interfering signal centre frequency offset from <i>Base Station RF Bandwidth</i> edge or edge of <i>sub-block</i> inside a gap	$\pm 0.8$ MHz $\pm 2.0$ MHz $\pm 3.2$ MHz $\pm 6.2$ MHz
NOTE:	Interfering signal positions that are partially or completely outside of any <i>downlink operating band</i> of the <i>TAB connector</i> are excluded from the requirement.

### 6.7.2.3 Additional co-location minimum requirement (BC3)

This additional requirement shall only apply for BS co-located with an UTRA TDD BS.

The transmitter intermodulation level shall not exceed the unwanted emission limits specified for transmitter spurious emission in subclause 6.6.6, operating band unwanted emission in subclause 6.6.5 and ACLR in subclause 6.6.3 in the presence of a wanted signal and an interfering signal according to table 6.7.2.3-1 for AAS BS operation in BC3.

For *TAB connectors* supporting operation in multiple operating bands, the requirement applies relative to the *Base Station RF Bandwidth edges* of each operating band. In case the *Inter RF Bandwidth gap* is less than 3.2 MHz, the requirement in the gap applies only for interfering signal offsets where the interfering signal falls completely within the inter *Base Station RF Bandwidth* gap.

**Table 6.7.2.3-1: Interfering signal for the co-location transmitter intermodulation requirement (BC3)**

Parameter	Value
Wanted signal type	E-UTRA or NR or UTRA signal
Interfering signal type	1,28 Mcps UTRA TDD signal of <i>channel bandwidth</i> 1,6 MHz
Interfering signal level	<i>Rated total output power per TAB connector</i> in the operating band ( $P_{\text{Rated,t,TABC}} - 30\text{dB}$ )
Interfering signal centre frequency offset from <i>Base Station RF Bandwidth</i> edge or edge of <i>sub-block</i> inside a gap	$\pm 0,8$ MHz $\pm 1,6$ MHz $\pm 2,4$ MHz
NOTE:	Interfering signal positions that are partially or completely outside of any <i>downlink operating band</i> of the base station are excluded from the requirement.

### 6.7.2.4 Additional co-location minimum requirements

### 6.7.2.5 Intra-system minimum requirement

The transmitter intermodulation level shall not exceed the unwanted emission limits specified for operating band unwanted emission in subclause 6.6.5 and ACLR in subclause 6.6.3 in the presence of a wanted signal and an interfering signal according to table 6.7.2.5-1 for BS operation in BC1, BC2 and BC3.

**Table 6.7.2.5-1: Interfering signal for intra-system transmitter intermodulation requirement**

Parameter	Value
Wanted signal type	E-UTRA or NR or UTRA
Interfering signal type	NR, E-UTRA or UTRA signal of the same type and <i>channel bandwidth</i> as the wanted signal (NOTE 1).
Interfering signal level	Power level declared by the base station manufacturer (NOTE 2).
Frequency offset between interfering signal and wanted signal	0 MHz
NOTE 1: The interfering signal shall be incoherent with the wanted signal.	
NOTE 2: The declared interfering signal power level at each <i>TAB connector</i> is the sum of the co-channel leakage power coupled via the combined RDN and Antenna Array from all the other <i>TAB connectors</i> , but does not comprise power radiated from the Antenna Array and reflected back from the environment. The power at each of the interfering <i>TAB connectors</i> is $P_{\text{Rated,c,TABC}}$ .	

### 6.7.3 Minimum requirement for single RAT UTRA operation

#### 6.7.3.1 General co-location minimum requirement for FDD UTRA

The transmitter intermodulation level shall not exceed the out of band emission or the spurious emission requirements of subclause 6.6.5 and subclause 6.6.6 in the presence of interfering signal according to table 6.7.3.1-1.

**Table 6.7.3.1-1: Interfering and wanted signal frequency offset for co-location requirement**

Parameter	Value
Wanted signal type	UTRA
Interfering signal type	UTRA
Interfering signal level	<i>Rated total output power per TAB connector</i> in the operating band ( $P_{\text{Rated,t,TABC}} - 30\text{dB}$ )
Interfering signal centre frequency offset from the lower (upper) edge of the wanted signal or edge of <i>sub-block</i> inside a gap	-2,5 MHz -7,5 MHz -12,5 MHz +2,5 MHz +7,5 MHz +12,5 MHz
NOTE 1: Interference frequencies that are outside of any allocated frequency band for UTRA-FDD downlink specified in subclause 4.6 are excluded from the requirement, unless the interfering signal positions fall within the frequency range of adjacent <i>downlink operating bands</i> in the same geographical area.	
NOTE 2: NOTE 1 is not applied in Band I, III, VI, VIII, IX, XI, XIX, XXI, and XXXII operating within 1 475.9 MHz to 1 495.9MHz, in certain regions.	

For *TAB connectors* supporting operation in *non-contiguous spectrum*, the requirement is also applicable inside a *sub-block gap* for interfering signal offsets where the interfering signal falls completely within the *sub-block gap*. The interfering signal offset is defined relative to the *sub-block* edges.

For *TAB connectors* supporting operation in multiple operating bands, the requirement is also applicable inside an inter *Base Station RF Bandwidth* gap for interfering signal offsets where the interfering signal falls completely within the inter *Base Station RF Bandwidth* gap.

#### 6.7.3.2 General co-location minimum requirement for 1,28 Mcps TDD UTRA

The transmitter intermodulation level shall not exceed the out of band emission or the spurious emission requirements of subclause 6.6.5 and subclause 6.6.6 in the presence of interfering signal according to table 6.7.3.2-1.

**Table 6.7.3.2-1: Interfering and wanted signals frequency offset for co-location requirement**

Parameter	Value
Wanted signal type	1,28 Mcps TDD UTRA
Interfering signal type	1,28 Mcps TDD UTRA
Interfering signal level	<i>Rated total output power per TAB connector</i> in the operating band ( $P_{\text{Rated,t,TABC}}$ ) – 30dB
Interfering signal centre frequency offset from the lower (upper) edge of the wanted signal	-0,8 MHz -2,4MHz -4,0 MHz +0,8 MHz +2,4 MHz +4,0 MHz
NOTE:	Interference frequencies that are outside of the allocated frequency band specified in subclause 4.6 are excluded from the requirement, unless the interfering signal positions fall within the frequency range of adjacent <i>downlink operating bands</i> in the same geographical area.

For *TAB connectors* supporting operation in *non-contiguous spectrum*, the requirement is also applicable inside a *sub-block gap* for interfering signal offsets where the interfering signal falls completely within the *sub-block gap*. The interfering signal offset is defined relative to the *sub-block* edges.

For *TAB connectors* supporting operation in multiple operating band, the requirement is also applicable inside an inter *Base Station RF Bandwidth* gap for interfering signal offsets where the interfering signal falls completely within the inter *Base Station RF Bandwidth* gap.

### 6.7.3.3 Intra-system minimum requirement

The transmitter intermodulation level shall not exceed the unwanted emission limits specified for operating band unwanted emission in subclause 6.6.5 and ACLR in subclause 6.6.3 in the presence of a wanted signal and an interfering signal according to table 6.7.3.3-1 for AAS BS.

**Table 6.7.3.3-1: Interfering and wanted signals for intra-system transmitter intermodulation requirement**

Parameter	Value
Wanted signal type	UTRA or 1,28 Mcps TDD UTRA
Interfering signal type	UTRA or 1,28 Mcps TDD UTRA signal of the same <i>channel bandwidth</i> as the wanted signal (NOTE 1).
Interfering signal level	Power level declared by the base station manufacturer (NOTE 2).
Frequency offset between interfering signal and wanted signal	0 MHz
NOTE 1:	The interfering signal shall be incoherent with the wanted signal.
NOTE 2:	The declared interfering signal power level at each <i>TAB connector</i> is the sum of the co-channel leakage power coupled via the combined RDN and Antenna Array from all the other <i>TAB connectors</i> , but does not comprise power radiated from the Antenna Array and reflected back from the environment. The power at each of the interfering <i>TAB connectors</i> is $P_{\text{Rated,c,TABC}}$ .

## 6.7.4 Minimum requirement for single RAT E-UTRA operation

### 6.7.4.1 General co-location minimum requirement

The transmitter intermodulation level shall not exceed the unwanted emission limits in subclauses 6.6.6, 6.6.5 and 6.6.3 in the presence of an E-UTRA interfering signal according to table 6.7.4.1-1.

The requirement is applicable outside the *Base Station RF Bandwidth* or *Radio Bandwidth*. The interfering signal offset is defined relative to the *Base Station RF Bandwidth edges* or *Radio Bandwidth edges*.

For *TAB connectors* supporting operation in *non-contiguous spectrum*, the requirement is also applicable inside a *sub-block gap* for interfering signal offsets where the interfering signal falls completely within the *sub-block gap*. The interfering signal offset is defined relative to the *sub-block* edges.

For *TAB connectors* supporting operation in multiple operating bands, the requirement applies relative to the *Base Station RF Bandwidth edges* of each supported operating band. In case the inter *Base Station RF Bandwidth gap* is less than 15 MHz, the requirement in the gap applies only for interfering signal offsets where the interfering signal falls completely within the inter *Base Station RF Bandwidth gap*.

The wanted signal and interfering signal centre frequency is specified in table 6.7.4.1-1.

**Table 6.7.4.1-1: Interfering and wanted signals for the co-location transmitter intermodulation requirement**

Parameter	Value
Wanted signal	E-UTRA single carrier, or multi-carrier, or multiple intra-band contiguously or non-contiguously aggregated carriers
Interfering signal type	E-UTRA signal of <i>channel bandwidth</i> 5 MHz
Interfering signal level	<i>Rated total output power per TAB connector</i> in the operating band ( $P_{\text{Rated,t,TABC}} - 30\text{dB}$ )
Interfering signal centre frequency offset from the lower (upper) edge of the wanted signal or edge of <i>sub-block</i> inside a <i>sub-block gap</i>	$\pm 2,5$ MHz $\pm 7,5$ MHz $\pm 12,5$ MHz
NOTE 1: Interfering signal positions that are partially or completely outside of any <i>downlink operating band</i> of the base station are excluded from the requirement, unless the interfering signal positions fall within the frequency range of adjacent <i>downlink operating bands</i> in the same geographical area. In case that none of the interfering signal positions fall completely within the frequency range of the <i>downlink operating band</i> , 3GPP TS 36.141 [20] provides further guidance regarding appropriate test requirements.	
NOTE 2: In certain regions, NOTE 1 is not applied in Band 1, 3, 8, 9, 11, 18, 19, 21, 28, 32 operating within 1 475.9 MHz to 1 495.9 MHz, 34, 74.	

#### 6.7.4.2 Void

**Table 6.7.4.2-1: Void**

#### 6.7.4.3 Intra-system minimum requirement

The transmitter intermodulation level shall not exceed the unwanted emission limits specified for operating band unwanted emission in subclause 6.6.5 and ACLR in subclause 6.6.3 in the presence of a wanted signal and an interfering signal according to table 6.7.4.3-1 for AAS BS.

**Table 6.7.4.3-1: Interfering and wanted signals for intra-system transmitter intermodulation requirement**

Parameter	Value
Wanted signal type	E-UTRA
Interfering signal type	E-UTRA signal of the same <i>channel bandwidth</i> as the wanted signal (NOTE 1).
Interfering signal level	Power level declared by the base station manufacturer (NOTE 2).
Frequency offset between interfering signal and wanted signal	0 MHz
NOTE 1: The interfering signal shall be incoherent with the wanted signal.	
NOTE 2: The declared interfering signal power level at each <i>TAB connector</i> is the sum of the co-channel leakage power coupled via the combined RDN and Antenna Array from all the other <i>TAB connectors</i> , but does not comprise power radiated from the Antenna Array and reflected back from the environment. The power at each of the interfering <i>TAB connectors</i> is $P_{\text{Rated,c,TABC}}$ .	

## 7 Conducted receiver characteristics

### 7.1 General

Unless otherwise stated, the receiver characteristics are specified at the AAS BS *TAB connector* with full complement of transceivers for the configuration in normal operating condition. For FDD operation the requirements in clause 7 shall be met with the transmitter unit(s) on.

NOTE 1: In normal operating condition the BS in FDD operation is configured to transmit and receive at the same time.

NOTE 2: In normal operating condition the BS in TDD operation is configured to TX OFF power during *receive period*.

The manufacturer shall declare the minimum number of supported geographical cells (i.e. geographical areas). The minimum number of supported geographical cells ( $N_{\text{cells}}$ ) relates to the AAS BS setting with minimum amount of cell splitting. The manufacturer shall also declare *TAB connector RX min cell groups* for this minimum number of cells configuration. Every *TAB connector* supporting reception in an operating band shall map to one *TAB connector RX min cell group* supporting the same. The mapping of *TAB connectors* to cells is implementation dependent.

The number of active receiver units that are considered when calculating the emission limit ( $N_{\text{RXU,counted}}$ ) for an AAS BS is calculated as follows:

$N_{\text{RXU,counted}} = \min(N_{\text{RXU,active}}, 8 \times N_{\text{cells}})$  for AAS BS in *single RAT E-UTRA operation* and MSR AAS BS (excluding UTRA only MSR AAS BS).

And

$N_{\text{RXU,counted}} = \min(N_{\text{RXU,active}}, 4 \times N_{\text{cells}})$  for AAS BS in *single RAT UTRA operation* and UTRA only MSR AAS BS.

Further:

$$N_{\text{RXU,countedpercell}} = N_{\text{RXU,counted}} / N_{\text{cells}}$$

$N_{\text{RXU,countedpercell}}$  is used for scaling the *basic limits* as described in subclause 7.6.

NOTE 3:  $N_{\text{RXU,active}}$  is the number of actually active receiver units and is independent to the declaration of  $N_{\text{cells}}$ .

Any receiver requirement specified for NB-IoT in-band, NB-IoT guard band, or standalone NB-IoT operation in 3GPP TS 36.104 [4] for E-UTRA with NB-IoT (in-band or guard band) or for standalone NB-IoT, or in 3GPP TS 37.104 [5] for E-UTRA with NB-IoT or standalone NB-IoT in *MSR operation*, and referred in clause 7, is not applicable for AAS BS.

Any receiver requirement specified for Band 46 operation or for Band 49 operation in 3GPP TS 36.104 [4] for E-UTRA, or in 3GPP TS 37.104 [5] for E-UTRA in *MSR operation*, and referred in clause 7, is not applicable for AAS BS. The requirements for co-location blocking for Band 46 or Band 49 are applicable for AAS BS.

## 7.2 Reference sensitivity level

### 7.2.1 General

The reference sensitivity power level  $P_{\text{REFSENS}}$  is the minimum mean power received at the *TAB connector* at which a reference performance requirement shall be met for a specified reference measurement channel.

### 7.2.2 Minimum requirement for MSR operation

For UTRA, the minimum requirement for reference sensitivity is specified in subclause 7.2.3.

For E-UTRA, the minimum requirement for reference sensitivity is specified in subclause 7.2.4.

For NR, the minimum requirement for reference sensitivity is that same as that specified for *BS type 1-H* in 3GPP TS 38.104 [28] in subclause 7.2.2.

### 7.2.3 Minimum requirement for single RAT UTRA operation

The single RAT UTRA FDD AAS BS of Wide Area BS class shall fulfil minimum requirements for reference sensitivity specified in 3GPP TS 25.104 [6], subclause 7.2.1.

The single RAT UTRA FDD AAS BS of Medium Range BS class shall fulfil minimum requirements for reference sensitivity specified in 3GPP TS 25.104 [6], subclause 7.2.1.

The single RAT UTRA FDD AAS BS of Local Area BS class shall fulfil minimum requirements for reference sensitivity specified in 3GPP TS 25.104 [6], subclause 7.2.1.

The single RAT UTRA TDD AAS BS of Wide Area BS class shall fulfil minimum requirements for reference sensitivity specified in 3GPP TS 25.105 [7], subclause 7.2.1.1.

The single RAT UTRA TDD AAS BS of Local Area BS class shall fulfil minimum requirements for reference sensitivity specified in 3GPP TS 25.105 [7], subclause 7.2.1.1.

### 7.2.4 Minimum requirement for single RAT E-UTRA operation

The single RAT E-UTRA AAS BS of Wide Area BS class shall fulfil minimum requirements for reference sensitivity specified in 3GPP TS 36.104 [8], subclause 7.2.1.

The single RAT E-UTRA AAS BS of Medium Range BS class shall fulfil minimum requirements for reference sensitivity specified in 3GPP TS 36.104 [8], subclause 7.2.1.

The single RAT E-UTRA AAS BS of Local Area BS class shall fulfil minimum requirements for reference sensitivity specified in 3GPP TS 36.104 [8], subclause 7.2.1.

## 7.3 Dynamic range

### 7.3.1 General

The dynamic range is a measure of the capability of the receiver unit to receive a wanted signal in the presence of an interfering signal at the *TAB connector* inside the received *channel bandwidth* or the capability of receiving high level of wanted signal.

## 7.3.2 Minimum requirement for MSR operation

For UTRA, the minimum requirement for dynamic range is specified in subclause 7.3.3.

For E-UTRA, the minimum requirement for dynamic range is specified in subclause 7.3.4.

For NR, the minimum requirement for dynamic range is is that same as that specified for *BS type 1-H* in 3GPP TS 38.104 [28] in subclause 7.3.2.

## 7.3.3 Minimum requirement for single RAT UTRA operation

The single RAT UTRA FDD AAS BS of Wide Area BS class shall fulfil minimum requirements for dynamic range specified in 3GPP TS 25.104 [6], subclause 7.3.1.

The single RAT UTRA FDD AAS BS of Medium Range BS class shall fulfil minimum requirements for dynamic range specified in 3GPP TS 25.104 [6], subclause 7.3.1.

The single RAT UTRA FDD AAS BS of Local Area BS class shall fulfil minimum requirements for dynamic range specified in 3GPP TS 25.104 [6], subclause 7.3.1.

The single RAT UTRA TDD AAS BS of Wide Area BS class shall fulfil minimum requirements for dynamic range specified in 3GPP TS 25.105 [7], subclause 7.3.1.1.

The single RAT UTRA TDD AAS BS of Local Area BS class shall fulfil minimum requirements for dynamic range specified in 3GPP TS 25.105 [7], subclause 7.3.1.1.

## 7.3.4 Minimum requirement for single RAT E-UTRA operation

The single RAT E-UTRA AAS BS of Wide Area BS class shall fulfil minimum requirements for dynamic range specified in 3GPP TS 36.104 [8], subclause 7.3.1.

The single RAT E-UTRA AAS BS of Medium Range BS class shall fulfil minimum requirements for dynamic range specified in 3GPP TS 36.104 [8], subclause 7.3.1.

The single RAT E-UTRA AAS BS of Local Area BS class shall fulfil minimum requirements for dynamic range specified in 3GPP TS 36.104 [8], subclause 7.3.1.

# 7.4 Adjacent channel selectivity, general blocking, and narrowband blocking

## 7.4.1 General

The adjacent channel selectivity (ACS), general blocking and narrowband blocking characteristics are measures of the receiver unit ability to receive a wanted signal at its assigned channel at the *TAB connector* in the presence of an unwanted interferer inside the operating band.

NOTE: For Single RAT requirements, the in-band selectivity characteristics is referred to as "adjacent channel selectivity", whereas for the MSR requirements, the corresponding property is referred to as "general blocking" since the adjacent frequency range may not carry a channel addressable from the interfered carrier.

The in-band blocking requirement applies from  $F_{UL\_low} - \Delta f_{OOB}$  to  $F_{UL\_high} + \Delta f_{OOB}$ , excluding the downlink frequency range of the FDD *operating band*. The values of  $\Delta f_{OOB}$  are defined in table 7.4.1-1.

**Table 7.4.1-1:  $\Delta f_{OOB}$  offset for operating bands**

<b>Operating band characteristics</b>	<b><math>\Delta f_{OOB}</math> [MHz]</b>
$F_{UL\_high} - F_{UL\_low} < 100$ MHz	20
$100$ MHz $\leq F_{UL\_high} - F_{UL\_low} \leq 900$ MHz	60

## 7.4.2 Minimum requirement for MSR operation

### 7.4.2.1 General minimum requirement

For the general blocking requirement, the interfering signal shall be a UTRA FDD signal as specified in 3GPP TS 37.104 [9], annex A.1 for a UTRA, E-UTRA or NR ( $\leq 20$  MHz) wanted signal. The interfering signal shall be a 20 MHz E-UTRA signal for NR wanted signal channel bandwidth greater than 20MHz.

The requirement is applicable outside the *Base Station RF Bandwidth* or *Radio Bandwidth*. The interfering signal offset is defined relative to the *Base Station RF Bandwidth edges* or *Radio Bandwidth edges* applicable to each *TAB connector*.

For *TAB connector* supporting operation in *non-contiguous spectrum*, the requirement applies in addition inside any *sub-block gap*, in case the *sub-block gap* size is at least 15 MHz. The interfering signal offset is defined relative to the *sub-block edges* inside the *sub-block gap*.

For *multi-band TAB connectors*, the requirement applies in addition inside any *Inter RF Bandwidth gap* at those connectors, in case the gap size is at least 15 MHz. The interfering signal offset is defined relative to the *Base Station RF Bandwidth edges* inside the *Inter RF Bandwidth gap*.

For the wanted and interfering signal coupled to the *TAB connector*, using the parameters in tables 7.4.2.1-1 and 7.4.2.1-2, the following requirements shall be met:

- For any E-UTRA carrier, the throughput shall be  $\geq 95$  % of the *maximum throughput* of the reference measurement channel defined in 3GPP TS 36.104 [8], subclause 7.2.1.
- For any UTRA FDD carrier, the BER shall not exceed 0,001 for the reference measurement channel defined in 3GPP TS 25.104 [6], subclause 7.2.1.
- For any UTRA TDD carrier, the BER shall not exceed 0,001 for the reference measurement channel defined in 3GPP TS 25.105 [7], subclause 7.2.1.2.
- For any NR carrier, the throughput shall be  $\geq 95$ % of the maximum throughput of the reference measurement channel defined for *BS type 1-H* in TS 38.104 [28], subclause 7.2.2. For *multi-band TAB connectors*, the requirement applies according to table 7.4.2.1-1 at those connectors for the in-band blocking frequency ranges of each supported operating band.

Table 7.4.2.1-1: General blocking requirement

Base Station Type	Mean power of interfering signal [dBm]	Wanted Signal mean power [dBm] (NOTE 1)	Centre Frequency of Interfering Signal	Interfering signal centre frequency minimum offset from the <i>Base Station RF Bandwidth edge</i> or <i>edge of sub-block inside a gap</i> (MHz)
Wide Area BS	-40 + y (NOTE 7)	$P_{\text{REFSENS}} + x$ dB (NOTE 2,5)	$F_{\text{UL\_low}} - \Delta f_{\text{OOB}}$ to $F_{\text{UL\_high}} + \Delta f_{\text{OOB}}$ (Note 7)	$\pm(7.5+z)$ (NOTE 9)
Medium Range BS	-35 + y (NOTE 7)	$P_{\text{REFSENS}} + x$ dB (NOTE 3,5)		
Local Area BS	-30 + y (NOTE 7)	$P_{\text{REFSENS}} + x$ dB (NOTE 4,5)		
<p>NOTE 1: <math>P_{\text{REFSENS}}</math> depends on the RAT, the BS class and on the <i>channel bandwidth</i>, see subclause 7.2.2.</p> <p>NOTE 2: For WA BS supporting UTRA, "x" is equal to 6 in case of NR or E-UTRA or UTRA wanted signals.</p> <p>NOTE 3: For MR BS supporting UTRA, "x" is equal to 6 in case of UTRA wanted signals, 9 in case of NR or E-UTRA wanted signal.</p> <p>NOTE 4: For LA BS supporting UTRA, "x" is equal to 11 in case of NR or E-UTRA wanted signal, 6 in case of UTRA wanted signal.</p> <p>NOTE 5: For a BS not supporting UTRA, x is equal to 6 for all BS classes if NR is supported, otherwise "x" is equal to 6 for WA BS or 9 for MR BS or 11 for LA BS if NR is not supported.</p> <p>NOTE 6: For a BS capable of multi-band operation, "x" in Note 2, 3, 4, 5 applies in case of interfering signals that are in the in-band blocking frequency range of the operating band where the wanted signal is present or in the in-band blocking frequency range of an adjacent or overlapping operating band. For other in-band blocking frequency ranges of the interfering signal for the supported operating bands, "x" is equal to 1.4 dB.</p> <p>NOTE 7: For a BS that supports NR but does not support UTRA, "y" is equal to -3 for the WA and MR BS class and -5 for the LA BS class. For all other cases, "y" is equal to zero for all BS classes.</p> <p>NOTE 8: The downlink frequency range of an FDD operating band is excluded from the general blocking requirement.</p> <p>NOTE 9: For NR wanted signal channel bandwidth greater than 20 MHz, <math>z = 22.5</math>. For all other cases, <math>z = 0</math>.</p>				

Table 7.4.2.1-2: Void

NOTE: The requirement in table 7.4.2.1-1 assumes that two operating bands, where the *downlink operating band* (see subclause 4.5 in 3GPP TS 37.104 [9]) of one band would be within the in-band blocking region of the other band, are not deployed in the same geographical area.

### 7.4.2.2 General narrowband blocking minimum requirement

For the general narrowband blocking requirement, the interfering signal shall be an E-UTRA 1RB signal as specified in 3GPP TS 37.104 [9], annex A.3.

The requirement is applicable outside the *Base Station RF Bandwidth* or *Radio Bandwidth*. The interfering signal offset is defined relative to the *Base Station RF Bandwidth edges* or *Radio Bandwidth edges*.

For *TAB connectors* supporting operation in *non-contiguous spectrum*, the requirement applies in addition inside any *sub-block gap*, in case the *sub-block gap* size is at least 3 MHz. The interfering signal offset is defined relative to the *sub-block edges* inside the *sub-block gap*.

For *multi-band TAB connectors*, the requirement applies in addition inside any *Inter RF Bandwidth gap* at those connectors, in case the gap size is at least 3 MHz. The interfering signal offset is defined relative to the *Base Station RF Bandwidth edges* inside the *Inter RF Bandwidth gap*.

For the wanted and interfering signal coupled to the *TAB connector* using the parameters in table 7.4.2.2-1, the following requirements shall be met:

- For any E-UTRA carrier, the throughput shall be  $\geq 95$  % of the *maximum throughput* of the reference measurement channel defined in 3GPP TS 36.104 [8], subclause 7.2.1.

- For any UTRA FDD carrier, the BER shall not exceed 0,001 for the reference measurement channel defined in 3GPP TS 25.104 [6], subclause 7.2.1.
- For any UTRA TDD carrier, the BER shall not exceed 0,001 for the reference measurement channel defined in 3GPP TS 25.105 [7], subclause 7.2.1.2.
- For any NR carrier, the throughput shall be  $\geq 95\%$  of the maximum throughput of the reference measurement channel defined for *BS type I-H* in TS 38.104 [28], subclause 7.2.2.

Table 7.4.2.2-1: Narrowband blocking requirement

Base Station Type	RAT of the carrier	Wanted signal mean power [dBm] (NOTE 1, 2, 6)	Interfering signal mean power [dBm]	Interfering RB (NOTE 3) centre frequency offset from the AAS Base Station RF Bandwidth edge or edge of sub-block inside a gap [kHz]
Wide Area BS	E-UTRA, UTRA, NR	$P_{\text{REFSENS}} + x \text{ dB}$	-49	$\pm(240 + m \cdot 180)$ , $m=0, 1, 2, 3, 4, 9, 14$ (Note 4)
Medium Range BS			-44	
Local Area BS			-41	$\pm(550 + m \cdot 180)$ , $m=0, 1, 2, 3, 4, 29, 54, 79, 99$ (Note 5)
<p>NOTE 1: <math>P_{\text{REFSENS}}</math> depends on the RAT, the AAS BS class and on the <i>channel bandwidth</i>, see subclause 7.2.2.</p> <p>NOTE 2: "x" is equal to 6 dB in case of E-UTRA or UTRA or NR wanted signals.</p> <p>NOTE 3: Interfering signal (E-UTRA 3 MHz) consisting of one resource block positioned at the stated offset, the <i>channel bandwidth</i> of the interfering signal is located adjacently to the AAS Base Station RF Bandwidth edge.</p> <p>NOTE 4: Applicable for <i>channel bandwidths</i> equal to or below 20 MHz.</p> <p>NOTE 5: Applicable for <i>channel bandwidths</i> above 20 MHz.</p> <p>NOTE 6: 7.5 kHz shift is not applied to the wanted signal of NR.</p> <p>NOTE 7: Void</p>				

### 7.4.2.3 Additional BC3 blocking minimum requirement

This additional requirement only applies for BS operating in the same geographical area as UTRA TDD.

For the additional BC3 blocking requirement, the interfering signal is a 1,28 Mcps UTRA TDD signal as specified in 3GPP TS 37.104 [9], annex A.2.

The requirement is always applicable outside the *Base Station RF Bandwidth* or *Radio Bandwidth*. The interfering signal offset is defined relative to the *Base Station RF Bandwidth edges* or *Radio Bandwidth edges*.

For *multi-band TAB connectors*, the requirement applies in addition inside any *Inter RF Bandwidth gap* at those connectors, in case the gap size is at least 4.8 MHz. The interfering signal offset is defined relative to the *Base Station RF Bandwidth edges* inside the *Inter RF Bandwidth gap*.

For the wanted and interfering signal coupled to the *TAB connector*, using the parameters in table 7.4.2.3-1, the following requirements shall be met:

- For any E-UTRA TDD carrier, the throughput shall be  $\geq 95\%$  of the *maximum throughput* of the reference measurement channel defined in 3GPP TS 36.104 [8], subclause 7.2.1.
- For any UTRA TDD carrier, the BER shall not exceed 0,001 for the reference measurement channel defined in 3GPP TS 25.105 [7], subclause 7.2.1.2.

Table 7.4.2.3-1: Additional blocking requirement for BC3

Operating Band	Centre Frequency of Interfering Signal [MHz]	Interfering Signal mean power [dBm]	Wanted Signal mean power [dBm]	Interfering signal centre frequency minimum offset from the <i>Base Station RF Bandwidth edge</i> [MHz]
33 - 39	(F <sub>UL_low</sub> - 20) to (F <sub>UL_high</sub> + 20)	-40	P <sub>REFSENS</sub> + 6 dB (NOTE)	±2,4
40	(F <sub>UL_low</sub> - 60) to (F <sub>UL_high</sub> + 60)	-40	P <sub>REFSENS</sub> + 6 dB (NOTE)	±2,4
NOTE: P <sub>REFSENS</sub> depends on the RAT and on the <i>channel bandwidth</i> , see subclause 7.2.2.				

### 7.4.3 Minimum requirement for single RAT UTRA operation

The single RAT UTRA FDD AAS BS of Wide Area BS class shall fulfil minimum requirements for ACS and narrowband blocking specified in 3GPP TS 25.104 [6], subclause 7.4.

The single RAT UTRA FDD AAS BS of Medium Range BS class shall fulfil minimum requirements for ACS and narrowband blocking specified in 3GPP TS 25.104 [6], subclause 7.4.

The single RAT UTRA FDD Local Area BS class shall fulfil minimum requirements for ACS and narrowband blocking specified in 3GPP TS 25.104 [6], subclause 7.4.

The single RAT UTRA TDD AAS BS of Wide Area BS class shall fulfil minimum requirements for ACS and narrowband blocking specified in 3GPP TS 25.105 [7], subclause 7.4.

The single RAT UTRA TDD AAS BS of Local Area BS class shall fulfil minimum requirements for ACS and narrowband blocking specified in 3GPP TS 25.105 [7], subclause 7.4.

### 7.4.4 Minimum requirement for single RAT E-UTRA operation

The single RAT E-UTRA AAS BS of Wide Area BS class shall fulfil minimum requirements for ACS and narrowband blocking specified in 3GPP TS 36.104 [8], subclause 7.5.

The single RAT E-UTRA AAS BS of Medium Range BS class shall fulfil minimum requirements for ACS and narrowband blocking specified in 3GPP TS 36.104 [8], subclause 7.5.

The single RAT E-UTRA AAS BS of Local Area BS class shall fulfil minimum requirements for ACS and narrowband blocking specified in 3GPP TS 36.104 [8], subclause 7.5.

## 7.5 Blocking

### 7.5.1 General

The blocking characteristics are a measure of the receiver unit ability to receive a wanted signal at the *TAB connector* at its assigned channel in the presence of an unwanted interferer.

### 7.5.2 Minimum requirement for MSR operation

#### 7.5.2.1 General minimum requirement

For a wanted and an interfering signal coupled to the *TAB connector* using the parameters in table 7.5.2.1-1, the following requirements shall be met:

- For any E-UTRA carrier, the throughput shall be  $\geq 95\%$  of the *maximum throughput* of the reference measurement channel defined in 3GPP TS 36.104 [8], subclause 7.2.1.

- For any UTRA FDD carrier, the BER shall not exceed 0,001 for the reference measurement channel defined in 3GPP TS 25.104 [6], subclause 7.2.1.
- For any UTRA TDD carrier, the BER shall not exceed 0,001 for the reference measurement channel defined in 3GPP TS 25.105 [7], subclause 7.2.1.2.
- For any NR carrier, the throughput shall be  $\geq 95\%$  of the maximum throughput of the reference measurement channel defined for *BS type 1-H* in TS 38.104 [28], subclause 7.2.2.

For *multi-band TAB connectors*, the requirement applies for each supported operating band. The in-band blocking frequency ranges of all supported operating bands according to table 7.4.2.1-1 shall be excluded from the requirement.

The out-of-band blocking requirement applies from 1 MHz to  $F_{UL\_low} - \Delta f_{OOB}$  and from  $F_{UL\_high} + \Delta f_{OOB}$  up to 12750 MHz, including the downlink frequency range of the FDD *operating band* for BS supporting FDD.  $\Delta f_{OOB}$  is defined in table 7.4.1-1.

**Table 7.5.2.1-1: Blocking performance requirement**

Interfering Signal mean power [dBm]	Wanted Signal mean power [dBm]	Type of Interfering Signal
-15	$P_{REFSENS} + x\text{dB}$ (NOTE1)	CW carrier
NOTE1: $P_{REFSENS}$ depends on the RAT, the BS class and the channel bandwidth, see subclause 7.2. "x" is equal to 6 in case of NR, E-UTRA or UTRA wanted signals.		

### 7.5.2.2 Co-location minimum requirement

This additional blocking requirement may be applied for the protection of *AAS BS receivers* when NR, E-UTRA BS, UTRA BS, CDMA BS or GSM/EDGE BS operating in a different frequency band are co-located with an *AAS BS*.

The requirements in this subclause assume a 30 dB coupling loss between the interfering transmitter and the *AAS BS receiver* and are based on co-location with base stations of the same class.

For a wanted and an interfering signal coupled to the *TAB connector* using the parameters in table 7.5.2.2-1, the following requirements shall be met:

- For any E-UTRA carrier, the throughput shall be  $\geq 95\%$  of the *maximum throughput* of the reference measurement channel defined in 3GPP TS 36.104 [8], subclause 7.2.1.
- For any UTRA FDD carrier, the BER shall not exceed 0,001 for the reference measurement channel defined in 3GPP TS 25.104 [6], subclause 7.2.1.
- For any UTRA TDD carrier, the BER shall not exceed 0,001 for the reference measurement channel defined in 3GPP TS 25.105 [7], subclause 7.2.1.2.
- For any NR carrier, the throughput shall be  $\geq 95\%$  of the maximum throughput of the reference measurement channel defined for *BS type 1-H* in TS 38.104 [28], subclause 7.2.2.

**Table 7.5.2.2-1: Blocking requirement for co-location with BS in other frequency bands**

Type of co-located BS	Centre Frequency of Interfering Signal [MHz]	Interfering Signal mean power for WA BS [dBm]	Interfering Signal mean power for MR BS [dBm]	Interfering Signal mean power for LA BS [dBm]	Wanted Signal mean power [dBm]	Type of Interfering Signal
GSM850 or CDMA850	869 - 894	+16	+8	-6	$P_{\text{REFSENS}} + x$ dB (NOTE 1)	CW carrier
GSM900	921 - 960	+16	+8	-6	$P_{\text{REFSENS}} + x$ dB (NOTE 1)	CW carrier
DCS1800	1 805 - 1 880 (NOTE 4)	+16	+8	-6	$P_{\text{REFSENS}} + x$ dB (NOTE 1)	CW carrier
PCS1900	1 930 - 1 990	+16	+8	-6	$P_{\text{REFSENS}} + x$ dB (NOTE 1)	CW carrier
UTRA FDD Band I or E-UTRA Band 1 or NR band n1	2 110 - 2 170	+16	+8	-6	$P_{\text{REFSENS}} + x$ dB (NOTE 1)	CW carrier
UTRA FDD Band II or E-UTRA Band 2 or NR band n2	1 930 - 1 990	+16	+8	-6	$P_{\text{REFSENS}} + x$ dB (NOTE 1)	CW carrier
UTRA FDD Band III or E-UTRA Band 3 or NR band n3	1 805 - 1 880 (NOTE 4)	+16	+8	-6	$P_{\text{REFSENS}} + x$ dB (NOTE 1)	CW carrier
UTRA FDD Band IV or E-UTRA Band 4	2 110 - 2 155	+16	+8	-6	$P_{\text{REFSENS}} + x$ dB (NOTE 1)	CW carrier
UTRA FDD Band V or E-UTRA Band 5 or NR band n5	869 - 894	+16	+8	-6	$P_{\text{REFSENS}} + x$ dB (NOTE 1)	CW carrier
UTRA FDD Band VI or E-UTRA Band 6	875 - 885	+16	+8	-6	$P_{\text{REFSENS}} + x$ dB (NOTE 1)	CW carrier
UTRA FDD Band VII or E-UTRA Band 7 or NR band n7	2 620 - 2 690	+16	+8	-6	$P_{\text{REFSENS}} + x$ dB (NOTE 1)	CW carrier
UTRA FDD Band VIII or E-UTRA Band 8 or NR band n8	925 - 960	+16	+8	-6	$P_{\text{REFSENS}} + x$ dB (NOTE 1)	CW carrier
UTRA FDD Band IX or E-UTRA Band 9	1 844.9 - 1 879.9	+16	+8	-6	$P_{\text{REFSENS}} + x$ dB (NOTE 1)	CW carrier
UTRA FDD Band X or E-UTRA Band 10	2 110 - 2 170	+16	+8	-6	$P_{\text{REFSENS}} + x$ dB (NOTE 1)	CW carrier
UTRA FDD Band XI or E-UTRA Band 11	1 475.9 - 1 495.9	+16	+8	-6	$P_{\text{REFSENS}} + x$ dB (NOTE 1)	CW carrier
UTRA FDD Band XII or E-UTRA Band 12 or NR band n12	729 - 746	+16	+8	-6	$P_{\text{REFSENS}} + x$ dB (NOTE 1)	CW carrier
UTRA FDD Band XIII or E-UTRA Band 13 or NR band n13	746 - 756	+16	+8	-6	$P_{\text{REFSENS}} + x$ dB (NOTE 1)	CW carrier
UTRA FDD Band XIV or E-UTRA Band 14 or NR band n14	758 - 768	+16	+8	-6	$P_{\text{REFSENS}} + x$ dB (NOTE 1)	CW carrier
E-UTRA Band 17	734 - 746	+16	+8	-6	$P_{\text{REFSENS}} + x$ dB (NOTE 1)	CW carrier
E-UTRA Band 18 or NR Band n18	860 - 875	+16	+8	-6	$P_{\text{REFSENS}} + x$ dB (NOTE 1)	CW carrier
UTRA FDD Band XIX or E-UTRA Band 19	875 - 890	+16	+8	-6	$P_{\text{REFSENS}} + x$ dB (NOTE 1)	CW carrier
UTRA FDD Band XX or E-UTRA Band 20 or NR band n20	791 - 821	+16	+8	-6	$P_{\text{REFSENS}} + x$ dB (NOTE 1)	CW carrier
UTRA FDD Band XXI or E-UTRA Band 21	1 495.9 - 1 510.9	+16	+8	-6	$P_{\text{REFSENS}} + x$ dB (NOTE 1)	CW carrier
UTRA FDD Band XXII or E-UTRA Band 22	3 510 - 3 590	+16	+8	-6	$P_{\text{REFSENS}} + x$ dB (NOTE 1)	CW carrier
E-UTRA Band 24 or NR band n24	1 525 - 1 559	+16	+8	-6	$P_{\text{REFSENS}} + x$ dB (NOTE 1)	CW carrier

Type of co-located BS	Centre Frequency of Interfering Signal [MHz]	Interfering Signal mean power for WA BS [dBm]	Interfering Signal mean power for MR BS [dBm]	Interfering Signal mean power for LA BS [dBm]	Wanted Signal mean power [dBm]	Type of Interfering Signal
UTRA FDD Band XXV or E-UTRA Band 25 or NR band n25	1 930 - 1 995	+16	+8	-6	$P_{\text{REFSENS}} + x$ dB (NOTE 1)	CW carrier
UTRA FDD Band XXVI or E-UTRA Band 26 or NR band n26	859 - 894	+16	+8	-6	$P_{\text{REFSENS}} + x$ dB (NOTE 1)	CW carrier
E-UTRA Band 27	852 - 869	+16	+8	-6	$P_{\text{REFSENS}} + x$ dB (NOTE 1)	CW carrier
E-UTRA Band 28 or NR band n28	758 - 803	+16	+8	-6	$P_{\text{REFSENS}} + x$ dB (NOTE 1)	CW carrier
E-UTRA Band 29 or NR Band n29	717 - 728	+16	+8	-6	$P_{\text{REFSENS}} + 6$ dB (NOTE 1)	CW carrier
E-UTRA Band 30 or NR band n30	2 350 - 2 360	+16	+8	-6	$P_{\text{REFSENS}} + x$ dB (NOTE 1)	CW carrier
E-UTRA Band 31	462.5 - 467.5	+16	+8	-6	$P_{\text{REFSENS}} + 6$ dB (NOTE 1)	CW carrier
UTRA FDD Band XXXII or E-UTRA Band 32	1 452 - 1 496 (NOTE-5)	+16	+8	-6	$P_{\text{REFSENS}} + 6$ dB (NOTE 1)	CW carrier
UTRA TDD Band a) or E-UTRA TDD Band 33	1 900 - 1 920	+16	+8	-6	$P_{\text{REFSENS}} + x$ dB (NOTE 1)	CW carrier
UTRA TDD Band a) or E-UTRA TDD Band 34 or NR band n34	2 010 - 2 025	+16	+8	-6	$P_{\text{REFSENS}} + x$ dB (NOTE 1)	CW carrier
UTRA TDD Band b) or E-UTRA TDD Band 35	1 850 - 1 910	+16	+8	-6	$P_{\text{REFSENS}} + x$ dB (NOTE 1)	CW carrier
UTRA TDD Band b) or E-UTRA TDD Band 36	1 930 - 1 990	+16	+8	-6	$P_{\text{REFSENS}} + x$ dB (NOTE 1)	CW carrier
UTRA TDD Band c) or E-UTRA TDD Band 37	1 910 - 1 930	+16	+8	-6	$P_{\text{REFSENS}} + x$ dB (NOTE 1)	CW carrier
UTRA TDD Band d) or E-UTRA Band 38 or NR band n38	2 570 - 2 620	+16	+8	-6	$P_{\text{REFSENS}} + x$ dB (NOTE 1)	CW carrier
UTRA TDD Band f) or E-UTRA Band 39 or NR band n39	1 880 - 1 920	+16	+8	-6	$P_{\text{REFSENS}} + x$ dB (NOTE 1)	CW carrier
UTRA TDD Band e) or E-UTRA Band 40 or NR band n40	2 300 - 2 400	+16	+8	-6	$P_{\text{REFSENS}} + x$ dB (NOTE 1)	CW carrier
E-UTRA Band 41 or NR band n41	2 496 - 2 690	+16	+8	-6	$P_{\text{REFSENS}} + x$ dB (NOTE1)	CW carrier
E-UTRA Band 42	3 400 - 3 600	+16	+8	-6	$P_{\text{REFSENS}} + x$ dB (NOTE 1)	CW carrier
E-UTRA Band 43	3 600 - 3 800	+16	+8	-6	$P_{\text{REFSENS}} + x$ dB (NOTE 1)	CW carrier
E-UTRA Band 44	703 - 803	+16	+8	-6	$P_{\text{REFSENS}} + x$ dB (NOTE 1)	CW carrier
E-UTRA Band 45	1447 - 1467	+16	+8	-6	$P_{\text{REFSENS}} + x$ dB (NOTE 1)	CW carrier
E-UTRA Band 46 or NR Band n46	5150 - 5925	N/A	+8	-6	$P_{\text{REFSENS}} + x$ dB (NOTE 1)	CW carrier
E-UTRA Band 48 or NR band n48	3550 – 3700	+16	+8	-6	$P_{\text{REFSENS}} + x$ dB (NOTE 1)	CW carrier
E-UTRA Band 49	3550 – 3700	N/A	N/A	-6	$P_{\text{REFSENS}} + x$ dB*	CW carrier

Type of co-located BS	Centre Frequency of Interfering Signal [MHz]	Interfering Signal mean power for WA BS [dBm]	Interfering Signal mean power for MR BS [dBm]	Interfering Signal mean power for LA BS [dBm]	Wanted Signal mean power [dBm]	Type of Interfering Signal
E-UTRA Band 50	1432 – 1517	+16	+8	-6	PREFSENS + x dB*	CW carrier
E-UTRA Band 51 or NR band n51	1427– 1432	N/A	N/A	-6	PREFSENS + x dB*	CW carrier
E-UTRA Band 52	3300 - 3400 MHz	+16	+8	-6	PREFSENS + x dB (NOTE 1)	CW carrier
E-UTRA Band 53 or NR Band n53	2483.5 - 2495 MHz	N/A	+8	-6	PREFSENS + x dB (NOTE 1)	CW carrier
E-UTRA Band 65 or NR band n65	2110 – 2200	+16	+8	-6	PREFSENS + x dB (NOTE 1)	CW carrier
E-UTRA Band 66 or NR band n66	2110 – 2200	+16	+8	-6	PREFSENS + x dB (NOTE 1)	CW carrier
E-UTRA Band 67 or NR band n67	738 - 758	+16	+8	-6	PREFSENS + x dB (NOTE 1)	CW carrier
E-UTRA Band 68	753 - 783	+16	+8	-6	PREFSENS + x dB (NOTE 1)	CW carrier
E-UTRA Band 69	2570 - 2620	+16	+8	-6	PREFSENS + x dB (NOTE 1)	CW carrier
E-UTRA Band 70 or NR band n70	1995 – 2020	+16	+8	-6	PREFSENS + x dB (NOTE 1)	CW carrier
E-UTRA Band 71 or or NR band n71	617 - 652	+16	+8	-6	PREFSENS + x dB*	CW carrier
E-UTRA Band 72	461 - 466	+16	+8	-6	PREFSENS + 6dB*	CW carrier
E-UTRA Band 73	460 - 465	+16	+8	-6	PREFSENS + 6dB*	CW carrier
E-UTRA Band 74	1475 - 1518	+16	+8	-6	PREFSENS + x dB*	CW carrier
NR band n77	3300-4200	+16	+8	-6	PREFSENS + x dB*	CW carrier
NR band n78	3300 - 3800	+16	+8	-6	PREFSENS + x dB*	CW carrier
E-UTRA Band 85 or NR band n85	728 - 746	+16	+8	-6	PREFSENS + x dB*	CW carrier
E-UTRA Band 87	420 - 425	+16	+8	-6	PREFSENS + 6dB*	CW carrier
E-UTRA Band 88	422 - 427	+16	+8	-6	PREFSENS + 6dB*	CW carrier

Type of co-located BS	Centre Frequency of Interfering Signal [MHz]	Interfering Signal mean power for WA BS [dBm]	Interfering Signal mean power for MR BS [dBm]	Interfering Signal mean power for LA BS [dBm]	Wanted Signal mean power [dBm]	Type of Interfering Signal
NR Band n96	5925 - 7125	N/A	+8	-6	PREFSENS + x dB (NOTE 1)	CW carrier
NR band n100	919.4 - 925	+16	N/A	N/A	PREFSENS + x dB (NOTE 1)	CW carrier
NR Band n101	1900 - 1910	+16	N/A	N/A	PREFSENS + x dB (NOTE 1)	CW carrier
NR Band n102	5925 - 6425	N/A	+8	-6	PREFSENS + x dB (NOTE 1)	CW carrier
E-UTRA Band 103	757 - 758	+16	+8	-6	PREFSENS + 6dB*	CW carrier

NOTE 1: PREFSENS depends on the RAT, the BS class and the *channel bandwidth*, see subclause 7.2.2. "x" is equal to 6 dB in case of UTRA or E-UTRA or NR wanted signals.

NOTE 2: Except for a BS operating in Band 13, these requirements do not apply when the interfering signal falls within any of the supported *uplink operating band* or in the  $\Delta f_{00B}$  immediately outside any of the supported *uplink operating band*.  
For a BS operating in band 13 the requirements do not apply when the interfering signal falls within the frequency range 768 - 797 MHz.

NOTE 3: Some combinations of bands may not be possible to co-site based on the requirements above. The current state-of-the-art technology does not allow a single generic solution for co-location of UTRA TDD or E-UTRA TDD or NR TDD with E-UTRA FDD or NR TDD on adjacent frequencies for 30 dB BS-BS minimum coupling loss. However, there are certain site-engineering solutions that can be used. These techniques are addressed in 3GPP TR 25.942 [12].

NOTE 4: In China, the blocking requirement for co-location with DCS1800 and Band III BS is only applicable in the frequency range 1 805 - 1 850 MHz.

NOTE 5: For an AAS BS operating in band 11,21, or 74 the requirement for co-location with Band 32 applies for interfering signal within the frequency range 1 475.9 - 1 495.9 MHz.

NOTE 6: Co-located TDD base stations that are synchronized and using the same or adjacent operating band can receive without special co-location requirements. For unsynchronized base stations, special co-location requirements may apply that are not covered by the 3GPP specifications.

## 7.5.3 Minimum requirement for single RAT UTRA operation

### 7.5.3.1 General minimum requirement

The single RAT UTRA FDD AAS BS of Wide Area BS class shall fulfil minimum requirements for blocking specified in 3GPP TS 25.104 [6], subclause 7.5.1.

The single RAT UTRA FDD AAS BS of Medium Range BS class shall fulfil minimum requirements for blocking specified in 3GPP TS 25.104 [6], subclause 7.5.1.

The single RAT UTRA FDD AAS BS of Local Area BS class shall fulfil minimum requirements for blocking specified in 3GPP TS 25.104 [6], subclause 7.5.1.

The single RAT UTRA 1,28 Mcps TDD AAS BS of Wide Area BS class shall fulfil minimum requirements for blocking specified in 3GPP TS 25.105 [7], subclause 7.5.0.2.

The single RAT UTRA 1,28 Mcps TDD AAS BS of Local Area BS class shall fulfil minimum requirements for blocking specified in 3GPP TS 25.105 [7], subclause 7.5.0.2.

### 7.5.3.2 Co-location minimum requirement

The single RAT UTRA FDD AAS BS of Wide Area BS class may optionally fulfil minimum requirements for co-location blocking specified in 3GPP TS 25.104 [6], subclause 7.5.2.

The single RAT UTRA FDD AAS BS of Medium Range BS class may optionally fulfil minimum requirements for co-location blocking specified in 3GPP TS 25.104 [6], subclause 7.5.2.

The single RAT UTRA FDD AAS BS of Local Area BS class may optionally fulfil minimum requirements for co-location blocking specified in 3GPP TS 25.104 [6], subclause 7.5.2.

The single RAT UTRA 1,28 Mcps TDD AAS BS of Wide Area BS class may optionally fulfil minimum requirements for co-location blocking specified in 3GPP TS 25.105 [7], subclause 7.5.1.2.

The single RAT UTRA 1,28 Mcps TDD AAS BS of Local Area BS class may optionally fulfil minimum requirements for co-location blocking specified in 3GPP TS 25.105 [7], subclause 7.5.1.2.

## 7.5.4 Minimum requirement for single RAT E-UTRA operation

### 7.5.4.1 General minimum requirement

For E-UTRA, the throughput shall be  $\geq 95\%$  of the maximum throughput of the reference measurement channel, with a wanted and an interfering signal coupled to BS antenna input using the parameters in Tables 7.5.4.1-1, 7.5.4.1-2, 7.5.4.1-3 and 7.5.4.1-4. The reference measurement channel is defined in 3GPP TS 36.104 [8], subclause 7.2.1.

The blocking requirement is applicable outside the Base Station RF Bandwidth or Radio Bandwidth. The interfering signal offset is defined relative to the Base Station RF Bandwidth edges or Radio Bandwidth edges.

For a BS operating in non-contiguous spectrum within any operating band, the blocking requirement applies in addition inside any sub-block gap, in case the sub-block gap size is at least as wide as twice the interfering signal minimum offset in Table 7.5.4.1-4. The interfering signal offset is defined relative to the sub-block edges inside the sub-block gap.

For a BS capable of multi-band operation, the requirement in the in-band blocking frequency ranges applies for each supported operating band. The requirement applies in addition inside any Inter RF Bandwidth gap, in case the Inter RF Bandwidth gap size is at least as wide as twice the interfering signal minimum offset in Table 7.5.4.1-4.

For a BS capable of multi-band operation, the requirement in the out-of-band blocking frequency ranges apply for each operating band, with the exception that the in-band blocking frequency ranges of all supported operating bands according to Tables 7.5.4.1-1, 7.5.4.1-2 and 7.5.4.1-3 shall be excluded from the out-of-band blocking requirement.

Table 7.5.4.1-1: Blocking performance requirement for Wide Area BS for E-UTRA

Operating Band	Centre Frequency of Interfering Signal [MHz]	Interfering Signal mean power [dBm]	Wanted Signal mean power [dBm]	Interfering signal centre frequency minimum offset from the lower/upper Base Station RF Bandwidth edge or sub-block edge inside a sub-block gap [MHz]	Type of Interfering Signal
1-7, 9-11, 13, 14, 18, 19, 21-23, 24, 27, 30, 33-39, 45, 50, 65, 66, 68, 70	(F <sub>UL_low</sub> -20) to (F <sub>UL_high</sub> +20)	-43	P <sub>REFSENS</sub> +6dB*	See table 7.5.4.1-4	See table 7.5.4.1-4
	1 to (F <sub>UL_low</sub> -20) (F <sub>UL_high</sub> +20) to 12750	-15	P <sub>REFSENS</sub> +6dB*	—	CW carrier
40-44, 48, 52	(F <sub>UL_low</sub> -60) to (F <sub>UL_high</sub> +60)	-43	P <sub>REFSENS</sub> +6dB*	See table 7.5.4.1-4	See table 7.5.4.1-4
	1 to (F <sub>UL_low</sub> -60) (F <sub>UL_high</sub> +60) to 12750	-15	P <sub>REFSENS</sub> +6dB*	—	CW carrier
8, 26, 28	(F <sub>UL_low</sub> -20) to (F <sub>UL_high</sub> +10)	-43	P <sub>REFSENS</sub> +6dB*	See table 7.5.4.1-4	See table 7.5.4.1-4
	1 to (F <sub>UL_low</sub> -20) (F <sub>UL_high</sub> +10) to 12750	-15	P <sub>REFSENS</sub> +6dB*	—	CW carrier
12	(F <sub>UL_low</sub> -20) to (F <sub>UL_high</sub> +13)	-43	P <sub>REFSENS</sub> +6dB*	See table 7.5.4.1-4	See table 7.5.4.1-4
	1 to (F <sub>UL_low</sub> -20) (F <sub>UL_high</sub> +13) to 12750	-15	P <sub>REFSENS</sub> +6dB*	—	CW carrier
17	(F <sub>UL_low</sub> -20) to (F <sub>UL_high</sub> +18)	-43	P <sub>REFSENS</sub> +6dB*	See table 7.5.4.1-4	See table 7.5.4.1-4
	1 to (F <sub>UL_low</sub> -20) (F <sub>UL_high</sub> +18) to 12750	-15	P <sub>REFSENS</sub> +6dB*	—	CW carrier
20, 71	(F <sub>UL_low</sub> -11) to (F <sub>UL_high</sub> +20)	-43	P <sub>REFSENS</sub> +6dB*	See table 7.5.4.1-4	See table 7.5.4.1-4
	1 to (F <sub>UL_low</sub> -11) (F <sub>UL_high</sub> +20) to 12750	-15	P <sub>REFSENS</sub> +6dB*	—	CW carrier
25	(F <sub>UL_low</sub> -20) to (F <sub>UL_high</sub> +15)	-43	P <sub>REFSENS</sub> +6dB*	See table 7.5.4.1-4	See table 7.5.4.1-4
	1 to (F <sub>UL_low</sub> -20) (F <sub>UL_high</sub> +15) to 12750	-15	P <sub>REFSENS</sub> +6dB*	—	CW carrier
31, 72, 73, 74, 87, 88	(F <sub>UL_low</sub> -20) to (F <sub>UL_high</sub> +5)	-43	P <sub>REFSENS</sub> +6dB*	See table 7.5.4.1-4	See table 7.5.4.1-4
	1 to (F <sub>UL_low</sub> -20) (F <sub>UL_high</sub> +5) to 12750	-15	P <sub>REFSENS</sub> +6dB*	—	CW carrier
85	(F <sub>UL_low</sub> -20) to (F <sub>UL_high</sub> +12)	-43	P <sub>REFSENS</sub> +6dB*	See table 7.5.4.1-4	See table 7.5.4.1-4
	1 to (F <sub>UL_low</sub> -20) (F <sub>UL_high</sub> +12) to 12750	-15	P <sub>REFSENS</sub> +6dB*	—	CW carrier
Note*:	P <sub>REFSENS</sub> depends on the channel bandwidth as specified in 3GPP TS 36.104 [8], subclause 7.2.1.				
Note**:	For a BS capable of multiband operation, in case of interfering signal that is not in the in-band blocking frequency range of the operating band where the wanted signal is present, and not in the in-band blocking frequency range of an adjacent or overlapping operating band, the wanted signal mean power is equal to P <sub>REFSENS</sub> + 1.4 dB.				

NOTE: Table 7.5.4.1-1 assumes that two operating bands, where the downlink operating band of one band would be within the in-band blocking region of the other band, are not deployed in the same geographical area.

Table 7.5.4.1-2: Blocking performance requirement for Local Area BS for E-UTRA

Operating Band	Centre Frequency of Interfering Signal [MHz]	Interfering Signal mean power [dBm]	Wanted Signal mean power [dBm]	Interfering signal centre frequency minimum offset from the lower/upper Base Station RF Bandwidth edge or sub-block edge inside a sub-block gap [MHz]	Type of Interfering Signal
1-7, 9-11, 13, 14, 18, 19, 21-23, 24, 27, 30, 33-39, 45, 50, 51, 65, 66, 68, 70	(F <sub>UL_low</sub> -20) to (F <sub>UL_high</sub> +20)	-35	P <sub>REFSENS</sub> +6dB*	See table 7.5.4.1-4	See table 7.5.4.1-4
	1 to (F <sub>UL_low</sub> -20) (F <sub>UL_high</sub> +20) to 12750	-15	P <sub>REFSENS</sub> +6dB*	—	CW carrier
40-44, 48, 52	(F <sub>UL_low</sub> -60) to (F <sub>UL_high</sub> +60)	-35	P <sub>REFSENS</sub> +6dB*	See table 7.5.4.1-4	See table 7.5.4.1-4
	1 to (F <sub>UL_low</sub> -60) (F <sub>UL_high</sub> +60) to 12750	-15	P <sub>REFSENS</sub> +6dB*	—	CW carrier
8, 26, 28	(F <sub>UL_low</sub> -20) to (F <sub>UL_high</sub> +10)	-35	P <sub>REFSENS</sub> +6dB*	See table 7.5.4.1-4	See table 7.5.4.1-4
	1 to (F <sub>UL_low</sub> -20) (F <sub>UL_high</sub> +10) to 12750	-15	P <sub>REFSENS</sub> +6dB*	—	CW carrier
12	(F <sub>UL_low</sub> -20) to (F <sub>UL_high</sub> +13)	-35	P <sub>REFSENS</sub> +6dB*	See table 7.5.4.1-4	See table 7.5.4.1-4
	1 to (F <sub>UL_low</sub> -20) (F <sub>UL_high</sub> +13) to 12750	-15	P <sub>REFSENS</sub> +6dB*	—	CW carrier
17	(F <sub>UL_low</sub> -20) to (F <sub>UL_high</sub> +18)	-35	P <sub>REFSENS</sub> +6dB*	See table 7.5.4.1-4	See table 7.5.4.1-4
	1 to (F <sub>UL_low</sub> -20) (F <sub>UL_high</sub> +18) to 12750	-15	P <sub>REFSENS</sub> +6dB*	—	CW carrier
20, 71	(F <sub>UL_low</sub> -11) to (F <sub>UL_high</sub> +20)	-35	P <sub>REFSENS</sub> +6dB*	See table 7.5.4.1-4	See table 7.5.4.1-4
	1 to (F <sub>UL_low</sub> -11) (F <sub>UL_high</sub> +20) to 12750	-15	P <sub>REFSENS</sub> +6dB*	—	CW carrier
25	(F <sub>UL_low</sub> -20) to (F <sub>UL_high</sub> +15)	-35	P <sub>REFSENS</sub> +6dB*	See table 7.5.4.1-4	See table 7.5.4.1-4
	1 to (F <sub>UL_low</sub> -20) (F <sub>UL_high</sub> +15) to 12750	-15	P <sub>REFSENS</sub> +6dB*	—	CW carrier
31, 72, 73, 74, 87, 88	(F <sub>UL_low</sub> -20) to (F <sub>UL_high</sub> +5)	-35	P <sub>REFSENS</sub> +6dB*	See table 7.5.4.1-4	See table 7.5.4.1-4
	1 to (F <sub>UL_low</sub> -20) (F <sub>UL_high</sub> +5) to 12750	-15	P <sub>REFSENS</sub> +6dB*	—	CW carrier
85	(F <sub>UL_low</sub> -20) to (F <sub>UL_high</sub> +12)	-35	P <sub>REFSENS</sub> +6dB*	See table 7.5.4.1-4	See table 7.5.4.1-4
	1 to (F <sub>UL_low</sub> -20) (F <sub>UL_high</sub> +12) to 12750	-15	P <sub>REFSENS</sub> +6dB*	—	CW carrier
Note*:	P <sub>REFSENS</sub> depends on the channel bandwidth as specified in 3GPP TS 36.104 [8], subclause 7.2.1.				
Note**:	For a BS capable of multiband operation, in case of interfering signal that is not in the in-band blocking frequency range of the operating band where the wanted signal is present, and not in the in-band blocking frequency range of an adjacent or overlapping operating band, the wanted signal mean power is equal to P <sub>REFSENS</sub> + 1.4 dB.				

NOTE: Table 7.5.4.1-2 assumes that two operating bands, where the downlink operating band of one band would be within the in-band blocking region of the other band, are not deployed in the same geographical area.

Table 7.5.4.1-3: Blocking performance requirement for Medium Range BS for E-UTRA

Operating Band	Centre Frequency of Interfering Signal [MHz]	Interfering Signal mean power [dBm]	Wanted Signal mean power [dBm]	Interfering signal centre frequency minimum offset from the lower/upper Base Station RF Bandwidth edge or sub-block edge inside a sub-block gap [MHz]	Type of Interfering Signal
1-7, 9-11, 13, 14, 18, 19, 21-23, 24, 27, 30, 33-39, 45, 50, 65, 66, 68, 70	(F <sub>UL_low</sub> -20) to (F <sub>UL_high</sub> +20)	-38	P <sub>REFSENS</sub> +6dB*	See table 7.5.4.1-4	See table 7.5.4.1-4
	1 to (F <sub>UL_low</sub> -20) (F <sub>UL_high</sub> +20) to 12750	-15	P <sub>REFSENS</sub> +6dB*	—	CW carrier
40-44, 48, 52	(F <sub>UL_low</sub> -60) to (F <sub>UL_high</sub> +60)	-38	P <sub>REFSENS</sub> +6dB*	See table 7.5.4.1-4	See table 7.5.4.1-4
	1 to (F <sub>UL_low</sub> -60) (F <sub>UL_high</sub> +60) to 12750	-15	P <sub>REFSENS</sub> +6dB*	—	CW carrier
8, 26, 28	(F <sub>UL_low</sub> -20) to (F <sub>UL_high</sub> +10)	-38	P <sub>REFSENS</sub> +6dB*	See table 7.5.4.1-4	See table 7.5.4.1-4
	1 to (F <sub>UL_low</sub> -20) (F <sub>UL_high</sub> +10) to 12750	-15	P <sub>REFSENS</sub> +6dB*	—	CW carrier
12	(F <sub>UL_low</sub> -20) to (F <sub>UL_high</sub> +13)	-38	P <sub>REFSENS</sub> +6dB*	See table 7.5.4.1-4	See table 7.5.4.1-4
	1 to (F <sub>UL_low</sub> -20) (F <sub>UL_high</sub> +13) to 12750	-15	P <sub>REFSENS</sub> +6dB*	—	CW carrier
17	(F <sub>UL_low</sub> -20) to (F <sub>UL_high</sub> +18)	-38	P <sub>REFSENS</sub> +6dB*	See table 7.5.4.1-4	See table 7.5.4.1-4
	1 to (F <sub>UL_low</sub> -20) (F <sub>UL_high</sub> +18) to 12750	-15	P <sub>REFSENS</sub> +6dB*	—	CW carrier
20, 71	(F <sub>UL_low</sub> -11) to (F <sub>UL_high</sub> +20)	-38	P <sub>REFSENS</sub> +6dB*	See table 7.5.4.1-4	See table 7.5.4.1-4
	1 to (F <sub>UL_low</sub> -11) (F <sub>UL_high</sub> +20) to 12750	-15	P <sub>REFSENS</sub> +6dB*	—	CW carrier
25	(F <sub>UL_low</sub> -20) to (F <sub>UL_high</sub> +15)	-38	P <sub>REFSENS</sub> +6dB*	See table 7.5.4.1-4	See table 7.5.4.1-4
	1 to (F <sub>UL_low</sub> -20) (F <sub>UL_high</sub> +15) to 12750	-15	P <sub>REFSENS</sub> +6dB*	—	CW carrier
31, 72, 73, 74, 87, 88	(F <sub>UL_low</sub> -20) to (F <sub>UL_high</sub> +5)	-38	P <sub>REFSENS</sub> +6dB*	See table 7.5.4.1-4	See table 7.5.4.1-4
	1 to (F <sub>UL_low</sub> -20) (F <sub>UL_high</sub> +5) to 12750	-15	P <sub>REFSENS</sub> +6dB*	—	CW carrier
85	(F <sub>UL_low</sub> -20) to (F <sub>UL_high</sub> +12)	-38	P <sub>REFSENS</sub> +6dB*	See table 7.5.4.1-4	See table 7.5.4.1-4
	1 to (F <sub>UL_low</sub> -20) (F <sub>UL_high</sub> +12) to 12750	-15	P <sub>REFSENS</sub> +6dB*	—	CW carrier
Note*:	P <sub>REFSENS</sub> depends on the channel bandwidth as specified in 3GPP TS 36.104 [8], subclause 7.2.1.				
Note**:	For a BS capable of multiband operation, in case of interfering signal that is not in the in-band blocking frequency range of the operating band where the wanted signal is present, and not in the in-band blocking frequency range of an adjacent or overlapping operating band, the wanted signal mean power is equal to P <sub>REFSENS</sub> + 1.4 dB.				

NOTE: Table 7.5.4.1-3 assumes that two operating bands, where the downlink operating band of one band would be within the in-band blocking region of the other band, are not deployed in the same geographical area.

Table 7.5.4.1-4: Interfering signals for blocking performance requirement

E-UTRA channel BW of the lowest/highest carrier received [MHz]	Interfering signal centre frequency minimum offset to the lower/upper Base Station RF Bandwidth edge or sub-block edge inside a sub-block gap [MHz]	Type of interfering signal
1.4	±2.1	1.4 MHz E-UTRA signal
3	±4.5	3 MHz E-UTRA signal
5	±7.5	5 MHz E-UTRA signal
10	±7.5	5 MHz E-UTRA signal
15	±7.5	5 MHz E-UTRA signal
20	±7.5	5 MHz E-UTRA signal (Note 1)
20	±30	20 MHz E-UTRA signal (Note 2)

### 7.5.4.2 Co-location minimum requirement

The single RAT E-UTRA AAS BS of Wide Area BS class may optionally fulfil minimum requirements for co-location blocking specified in 3GPP TS 36.104 [8], subclause 7.6.2.

The single RAT E-UTRA AAS BS of Medium Range BS class may optionally fulfil minimum requirements for co-location blocking specified in 3GPP TS 36.104 [8], subclause 7.6.2.

The single RAT E-UTRA AAS BS of Local Area BS class may optionally fulfil minimum requirements for co-location blocking specified in 3GPP TS 36.104 [8], subclause 7.6.2.

## 7.6 Receiver spurious emissions

### 7.6.1 General

The receiver spurious emissions power is the power of emissions generated or amplified in a receiver unit that appear at the *TAB connector*. The requirements apply to all AAS BS with separate RX and TX *TAB connectors*.

NOTE: In this case for FDD AAS BS the test is performed when both TX and RX are ON, with the TX *TAB connector* terminated.

For a *TAB connector* supporting both RX and TX in TDD, the requirements apply during the *transmitter OFF period*. For a *TAB connector* supporting both RX and TX in FDD, the receiver spurious requirements are superseded by the TX spurious requirements in subclause 6.6.6.

For RX only *multi-band TAB connector(s)*, the RX spurious emissions requirements are subject to exclusion zones in each supported operating band. For *multi-band TAB connector(s)* that both transmit and receive in operating band supporting TDD, RX spurious emissions requirements are applicable during the TX OFF period, and are subject to exclusion zones in each supported operating band. The unwanted emission level limit of a *TAB connector RX min cell group* is in general defined by the unwanted emission *basic limit* which is the same as the corresponding applicable *non-AAS BS* per transmitter requirement specified in 3GPP TS 25.104 [2], 3GPP TS 25.105 [3], 3GPP TS 36.104 [4] or 3GPP TS 37.104 [5], and its scaling by  $N_{RXU, \text{counted per cell}}$ . The *basic limits* and corresponding scaling are defined in each relevant subclause. The receiver spurious emission requirements are applied per the *TAB connector RX min cell groups* for all the configurations supported by the AAS BS.

## 7.6.2 Minimum requirement for MSR operation

### 7.6.2.1 General minimum requirement

The general MSR RX spurious emission *basic limits* are provided in table 7.6.2.1-1.

**Table 7.6.2.1-1: General spurious emissions *basic limits***

Frequency range	Basic limits	Measurement bandwidth	NOTE
30MHz - 1 GHz	-57 dBm	100 kHz	Note 1
1 GHz - 12.75 GHz	-47 dBm	1 MHz	Note 1, Note 2
12.75 GHz - 5 <sup>th</sup> harmonic of the upper frequency edge of the UL operating band in GHz	-47 dBm	1 MHz	Note 1, Note 2, Note 3
NOTE 1: <i>Measurement bandwidths</i> as in ITU-R SM.329 [14], s4.1.			
NOTE 2: Upper frequency as in ITU-R SM.329 [14], s2.5 table 1.			
NOTE 3: This spurious frequency range applies only for <i>operating bands</i> for which the 5 <sup>th</sup> harmonic of the upper frequency edge of the UL <i>operating band</i> is reaching beyond 12.75 GHz.			
NOTE 4: The frequency range from $F_{BW\ RF, DL, low} - \Delta f_{OBUE}$ (i.e. $\Delta f_{OBUE}$ below the lowest frequency of the BS transmitter <i>operating band</i> ) to $F_{BW\ RF, DL, high} + \Delta f_{OBUE}$ (i.e. $\Delta f_{OBUE}$ above the highest frequency of the BS transmitter <i>operating band</i> ) may be excluded from the requirement. $\Delta f_{OBUE}$ is defined in clause 6.6.1. For <i>multi-band TAB connectors</i> , the exclusion applies for all supported operating bands for those connectors.			

The RX spurious emissions requirements for an MSR AAS BS are that for each applicable *basic limit* specified in table 7.6.2.1-1 for each *TAB connector RX min cell group*, the power sum of emissions at the *TAB connectors* of the *TAB connector RX min cell group* shall not exceed an AAS BS limit specified as the *basic limit* + X, where  $X = 10\log_{10}(N_{RXU, counted\ per\ cell})$ , unless stated differently in regional regulation.

In addition to the *basic limits* in table 7.6.2.1-1, additional spurious emissions requirements in 3GPP TS 37.104 [9], subclause 6.6.1.3 form *basic limits* for additional receiver spurious emission requirements.

In case of FDD BS (for BC1 and BC2), the levels specified for Protection of the BS receivers of own or different BS in 3GPP TS 37.104 [9], subclause 6.6.1.2 form basic levels for additional receiver spurious emission requirements.

In addition, the requirements for co-location with other base stations specified in 3GPP TS 37.104 [9], subclause 6.6.1.4 may also form basic levels for co-location spurious emission requirements.

NOTE: Conformance to the *AAS BS receiver* spurious emissions requirement can be demonstrated by meeting at least one of the following criteria as determined by the manufacturer:

- 1) The sum of the spurious emissions power measured on each *TAB connector* in the *TAB connector RX min cell group* shall be less than or equal to the AAS BS limit as defined above for the respective frequency span.

Or

- 2) The spurious emissions power at each *TAB connector* shall be less than or equal to the AAS BS limit as defined above for the respective frequency span, scaled by  $-10\log_{10}(n)$ , where  $n$  is the number of *TAB connectors* in the *TAB connector RX min cell group*.

## 7.6.3 Minimum requirement for single RAT UTRA operation

The single RAT UTRA FDD wide area, medium range area and local area RX spurious emissions *basic limits* are the same as those specified in 3GPP TS 25.104 [6], subclause 7.7.1.

The single RAT UTRA TDD wide area and local area RX spurious emissions *basic limits* are the same as those specified in 3GPP TS 25.105 [7], subclause 7.7.1.2.

The RX spurious emissions requirements for a single RAT UTRA AAS BS are that for each applicable *basic limit* as specified in 3GPP TS 25.104 [6] or 3GPP TS 25.105 [7], for each *TAB connector RX min cell group*, the power sum of emissions at the *TAB connectors* of the *TAB connector RX min cell group* shall not exceed an AAS BS limit specified as the *basic limit* + X, where  $X = 10\log_{10}(N_{\text{RXU, counted per cell}})$ , unless stated differently in regional regulation.

NOTE: Conformance to the *AAS BS receiver* spurious emissions requirement can be demonstrated by meeting at least one of the following criteria as determined by the manufacturer:

- 1) The sum of the spurious emissions power measured on each *TAB connector* in the *TAB connector RX min cell group* shall be less than or equal to the AAS BS limit as defined above for the respective frequency span.

Or

- 2) The spurious emissions power at each *TAB connector* shall be less than or equal to the AAS BS limit as defined above for the respective frequency span, scaled by  $-10\log_{10}(n)$ , where  $n$  is the number of *TAB connectors* in the *TAB connector RX min cell group*.

## 7.6.4 Minimum requirement for single RAT E-UTRA operation

The single RAT E-UTRA wide area, medium range area and local area RX spurious emissions *basic limits* are the same as those specified in 3GPP TS 36.104 [8], subclause 7.7.1 with the exception that the frequency range around the band edge (within which the requirement is not applicable) is  $\Delta f_{\text{OBUE}}$ .

The RX spurious emissions requirements for a single RAT E-UTRA AAS BS are that for each applicable *basic limit* specified in 3GPP TS 36.104 [4] for each *TAB connector RX min cell group*, the power sum of emissions at the *TAB connectors* of the *TAB connector RX min cell group* shall not exceed an AAS limit specified as the *basic limit* + X, where  $X = 10\log_{10}(N_{\text{RXU, counted per cell}})$ , unless stated differently in regional regulation.

NOTE: Conformance to the *AAS BS receiver* spurious emissions requirement can be demonstrated by meeting at least one of the following criteria as determined by the manufacturer:

- 1) The sum of the emissions power measured on each *TAB connector* in the *TAB connector RX min cell group* shall be less than or equal to the AAS BS limit as defined above for the respective frequency span.

Or

- 2) The spurious emission power at each *TAB connector* shall be less than or equal to the AAS BS limit as defined above for the respective frequency span, scaled by  $-10\log_{10}(n)$ , where  $n$  is the number of *TAB connectors* in the *TAB connector RX min cell group*.

## 7.7 Receiver intermodulation

### 7.7.1 General

Third and higher order mixing of the two interfering RF signals can produce an interfering signal in the band of the desired channel. Intermodulation response rejection is a measure of the capability of the receiver unit to receive a wanted signal on its assigned channel frequency in the presence of two interfering signals which have a specific frequency relationship to the wanted signal. The requirement applies per *TAB connector*.

### 7.7.2 Minimum requirement for MSR operation

#### 7.7.2.1 General intermodulation minimum requirement

Interfering signals shall be a CW signal and an E-UTRA or UTRA signal as specified in 3GPP TS 37.104 [9], annex A.

The requirement is applicable outside the *Base Station RF Bandwidth* or *Radio Bandwidth*. The interfering signal offset is defined relative to the *Base Station RF Bandwidth edges* or *Radio Bandwidth edges*.

For *multi-band TAB connectors*, the requirement applies in addition inside any *Inter RF Bandwidth gap* at those connectors, in case the gap size is at least twice as wide as the UTRA/E-UTRA interfering signal centre frequency offset from the *Base Station RF Bandwidth edge*. The interfering signal offset is defined relative to the *Base Station RF Bandwidth edges* inside the *Inter RF Bandwidth gap*.

For the wanted signal at the assigned channel frequency and two interfering signals coupled to the *TAB connector*, using the parameters in tables 7.7.2.1-1 and 7.7.2.1-2, the following requirements shall be met:

- For any E-UTRA carrier, the throughput shall be  $\geq 95\%$  of the *maximum throughput* of the reference measurement channel defined in 3GPP TS 36.104 [8], subclause 7.2.1.
- For any UTRA FDD carrier, the BER shall not exceed 0,001 for the reference measurement channel defined in 3GPP TS 25.104 [6], subclause 7.2.1.
- For any UTRA TDD carrier, the BER shall not exceed 0,001 for the reference measurement channel defined in 3GPP TS 25.105 [7], subclause 7.2.1.2.
- For any NR carrier, the throughput shall be  $\geq 95\%$  of the maximum throughput of the reference measurement channel defined for *BS type 1-H* in TS 38.104 [28], subclause 7.2.2

**Table 7.7.2.1-1: General intermodulation requirement**

Base Station Type	Mean power of interfering signals [dBm]	Wanted Signal mean power [dBm]	Type of interfering signals
Wide Area BS	-48 + y (NOTE 6)	$P_{\text{REFSENS}} + x$ dB (NOTE 2, 5)	See table 7.7.2.1-2
Medium Range BS	-44 + y (NOTE 6)	$P_{\text{REFSENS}} + x$ dB (NOTE 3, 5)	
Local Area BS	-38 + y (NOTE 6)	$P_{\text{REFSENS}} + x$ dB (NOTE 4, 5)	
NOTE 1: $P_{\text{REFSENS}}$ depends on the RAT, the BS class and on the <i>channel bandwidth</i> , see subclause 7.2.2.			
NOTE 2: For WA BS supporting UTRA, "x" is equal to 6 in case of NR or E-UTRA or UTRA wanted signals.			
NOTE 3: For MR BS supporting UTRA, "x" is equal to 6 in case of UTRA wanted signals, 9 in case of NR or E-UTRA wanted signal.			
NOTE 4: For LA BS supporting UTRA, "x" is equal to 12 in case of NR or E-UTRA wanted signals, 6 in case of UTRA wanted signal.			
NOTE 5: For a BS not supporting UTRA, x is equal to 6 for all BS classes if NR is supported, otherwise x is equal to 6 for WA BS or 9 for MR or 12 for LA BS if NR is not supported.			
NOTE 6: For a BS that supports NR but not UTRA; "y" is equal to -4 for the WA BS class, -3 for the MR BS class and -6 for the LA BS class. For all other cases, "y" is equal to zero for all BS classes.			

Table 7.7.2.1-2: Interfering signals for intermodulation requirement

RAT of the carrier adjacent to the upper/lower Base Station RF Bandwidth edge	Interfering signal centre frequency offset from the Base Station RF Bandwidth edge [MHz]	Type of interfering signal
E-UTRA 1.4 MHz	$\pm 2,0$ (BC1 and BC3) / $\pm 2,1$ (BC2)	CW
	$\pm 4,9$	1,4 MHz E-UTRA signal
E-UTRA 3 MHz	$\pm 4,4$ (BC1 and BC3) / $\pm 4,5$ (BC2)	CW
	$\pm 10,5$	3 MHz E-UTRA signal
UTRA FDD and E-UTRA 5 MHz	$\pm 7,5$	CW
	$\pm 17,5$	5 MHz E-UTRA signal
E-UTRA 10 MHz	$\pm 7,375$	CW
	$\pm 17,5$	5 MHz E-UTRA signal
E-UTRA 15 MHz	$\pm 7,25$	CW
	$\pm 17,5$	5 MHz E-UTRA signal
E-UTRA 20 MHz	$\pm 7,125$	CW
	$\pm 17,5$	5 MHz E-UTRA signal
GSM/EDGE	$\pm 7,575$	CW
	$\pm 17,5$	5 MHz E-UTRA signal
1,28 Mcps UTRA TDD	$\pm 2,3$ (BC3)	CW
	$\pm 5,6$ (BC3)	1,28 Mcps UTRA TDD signal
NR 5 MHz	$\pm 7,5$	CW
	$\pm 17,5$	5MHz E-UTRA signal
NR 10 MHz	$\pm 7,465$	CW
	$\pm 17,5$	5MHz E-UTRA signal
NR 15 MHz	$\pm 7,43$	CW
	$\pm 17,5$	5MHz E-UTRA signal
NR 20 MHz	$\pm 7,395$	CW
	$\pm 17,5$	5MHz E-UTRA signal
NR 25 MHz	$\pm 7,465$	CW
	$\pm 25$	20MHz E-UTRA signal
NR 30 MHz	$\pm 7,43$	CW
	$\pm 25$	20MHz E-UTRA signal
NR 35 MHz	$\pm 7,44$	CW
	$\pm 25$	20 MHz E-UTRA signal
NR 40 MHz	$\pm 7,45$	CW
	$\pm 25$	20MHz E-UTRA signal
NR 45 MHz	$\pm 7,37$	CW
	$\pm 25$	20 MHz E-UTRA signal
NR 50 MHz	$\pm 7,35$	CW
	$\pm 25$	20MHz E-UTRA signal
NR 60 MHz	$\pm 7,49$	CW
	$\pm 25$	20MHz E-UTRA signal
NR 70 MHz	$\pm 7,42$	CW
	$\pm 25$	20MHz E-UTRA signal
NR 80 MHz	$\pm 7,44$	CW
	$\pm 25$	20MHz E-UTRA signal
NR 90 MHz	$\pm 7,46$	CW
	$\pm 25$	20MHz E-UTRA signal
NR 100 MHz	$\pm 7,48$	CW
	$\pm 25$	20MHz E-UTRA signal

### 7.7.2.2 General narrowband intermodulation minimum requirement

Interfering signals shall be a CW signal and an E-UTRA 1RB signal as specified in 3GPP TS 37.104 [9], annex A.

The requirement is applicable outside the *Base Station RF Bandwidth* or *Radio Bandwidth*. The interfering signal offset is defined relative to the *Base Station RF Bandwidth edges* or *Radio Bandwidth edges*.

For *TAB connector* supporting operation in *non-contiguous spectrum* within each supported operating band, the requirement applies in addition inside any *sub-block gap* in case the *sub-block gap* is at least as wide as the *channel bandwidth* of the E-UTRA interfering signal in table 7.7.2.2-2. The interfering signal offset is defined relative to the *sub-block* edges inside the gap.

For *multi-band TAB connectors*, the requirement applies in addition inside any *Inter RF Bandwidth gap* at those connectors in case the gap size is at least as wide as the E-UTRA interfering signal in table 7.7.2.2-2. The interfering signal offset is defined relative to the *Base Station RF Bandwidth edges* inside the *Inter RF Bandwidth gap*.

For the wanted signal at the assigned channel frequency and two interfering signals coupled to the *TAB connector*, using the parameters in tables 7.7.2.2-1 and 7.7.2.2-2, the following requirements shall be met:

- For any E-UTRA carrier, the throughput shall be  $\geq 95\%$  of the *maximum throughput* of the reference measurement channel defined in 3GPP TS 36.104 [8], subclause 7.2.1.
- For any UTRA FDD carrier, the BER shall not exceed 0,001 for the reference measurement channel defined in 3GPP TS 25.104 [6], subclause 7.2.1.
- For any UTRA TDD carrier, the BER shall not exceed 0,001 for the reference measurement channel defined in 3GPP TS 25.105 [7], subclause 7.2.1.2.
- For any NR carrier, the throughput shall be  $\geq 95\%$  of the maximum throughput of the reference measurement channel defined for *BS type I-H* in TS 38.104 [28], subclause 7.2.2

**Table 7.7.2.2-1: General narrowband intermodulation requirement**

Base Station Type	Mean power of interfering signals [dBm]	Wanted Signal mean power [dBm]	Type of interfering signals
Wide Area BS	-52	$P_{\text{REFSENS}} + x$ dB (NOTE)	See table 7.7.2.2-2
Medium Range BS	-47		
Local Area BS	-44		
NOTE: $P_{\text{REFSENS}}$ depends on the RAT, the BS class and on the <i>channel bandwidth</i> , see subclause 7.2.2. "x" is equal to 6 dB in case of E-UTRA or UTRA or NR wanted signals.			

**Table 7.7.2.2-2: Interfering signals for narrowband intermodulation requirement**

<b>RAT of the carrier adjacent to the upper/lower Base Station RF Bandwidth edge or edge of the sub-block</b>	<b>CW or 1RB interfering signal centre frequency offset from the Base Station RF Bandwidth edge or edge of sub-block inside a gap [kHz]</b>	<b>Type of interfering signal</b>
E-UTRA 1.4 MHz	$\pm 260$ (BC1 and BC3) / $\pm 270$ (BC2)	CW
	$\pm 970$ (BC1 and BC3) / $\pm 790$ (BC2)	1,4 MHz E-UTRA signal, 1 RB (NOTE 1)
E-UTRA 3 MHz	$\pm 260$ (BC1 and BC3) / $\pm 270$ (BC2)	CW
	$\pm 960$ (BC1 and BC3) / $\pm 780$ (BC2)	3,0 MHz E-UTRA signal, 1 RB (NOTE 1)
E-UTRA 5 MHz	$\pm 360$	CW
	$\pm 1\ 060$	5 MHz E-UTRA signal, 1 RB (NOTE 1)
E-UTRA 10 MHz (NOTE 2)	$\pm 325$	CW
	$\pm 1\ 240$	5 MHz E-UTRA signal, 1 RB (NOTE 1)
E-UTRA 15 MHz (NOTE 2)	$\pm 380$	CW
	$\pm 1\ 600$	5MHz E-UTRA signal, 1 RB (NOTE 1)
E-UTRA 20 MHz (NOTE 2)	$\pm 345$	CW
	$\pm 1\ 780$	5MHz E-UTRA signal, 1 RB (NOTE 1)
UTRA FDD	$\pm 345$ (BC1 and BC2)	CW
	$\pm 1\ 780$ (BC1 and BC2)	5MHz E-UTRA signal, 1 RB (NOTE 1)
GSM/EDGE	$\pm 340$	CW
	$\pm 880$	5MHz E-UTRA signal, 1 RB (NOTE 1)
1,28 Mcps UTRA TDD	$\pm 190$ (BC3)	CW
	$\pm 970$ (BC3)	1,4 MHz E-UTRA signal, 1 RB (NOTE 1)
NR 5 MHz	$\pm 360$	CW
	$\pm 1420$	E-UTRA signal, 1 RB (NOTE 1)
NR 10 MHz	$\pm 370$	CW
	$\pm 1960$	E-UTRA signal, 1 RB (NOTE 1)
NR 15 MHz (Note 2)	$\pm 380$	CW
	$\pm 1960$	E-UTRA signal, 1 RB (NOTE 1)
NR 20 MHz (Note 2)	$\pm 390$	CW
	$\pm 2320$	E-UTRA signal, 1 RB (NOTE 1)
NR 25 MHz (Note 2)	$\pm 325$	CW
	$\pm 2350$	E-UTRA signal, 1 RB (NOTE 1)
NR 30 MHz (Note 2)	$\pm 335$	CW
	$\pm 2350$	E-UTRA signal, 1 RB (NOTE 1)
NR 35 MHz (Note 2)	$\pm 345$	CW
	$\pm 2350$	E-UTRA signal, 1 RB (NOTE 1)
NR 40 MHz (Note 2)	$\pm 355$	CW
	$\pm 2710$	E-UTRA signal, 1 RB (NOTE 1)
NR 45 MHz (Note 2)	$\pm 365$	CW
	$\pm 2710$	E-UTRA signal, 1 RB (NOTE 1)
NR 50 MHz (Note 2)	$\pm 375$	CW
	$\pm 2710$	E-UTRA signal, 1 RB (NOTE 1)
NR 60 MHz (Note 2)	$\pm 395$	CW
	$\pm 2710$	E-UTRA signal, 1 RB (NOTE 1)
NR 70 MHz (Note 2)	$\pm 415$	CW
	$\pm 2710$	E-UTRA signal, 1 RB (NOTE 1)
NR 80 MHz (Note 2)	$\pm 435$	CW
	$\pm 2710$	E-UTRA signal, 1 RB (NOTE 1)
NR 90 MHz (Note 2)	$\pm 365$	CW
	$\pm 2530$	E-UTRA signal, 1 RB (NOTE 1)

NR 100 MHz (Note 2)	$\pm 385$	CW
	$\pm 2530$	E-UTRA signal, 1 RB (NOTE 1)
NOTE 1: Interfering signal consisting of one resource block positioned at the stated offset, the <i>channel bandwidth</i> of the interfering signal is located adjacently to the <i>Base Station RF Bandwidth edge</i> .		
NOTE 2: This requirement shall apply only for an E-UTRA FRC A1-3 mapped to the frequency range at the channel edge adjacent to the interfering signals.		

### 7.7.3 Minimum requirement for single RAT UTRA operation

The single RAT UTRA FDD AAS BS of Wide Area BS class shall fulfil minimum requirements for receiver intermodulation specified in 3GPP TS 25.104 [6], subclause 7.6.1.

The single RAT UTRA FDD AAS BS of Medium Range BS class shall fulfil minimum requirements for receiver intermodulation specified in 3GPP TS 25.104 [6], subclause 7.6.1.

The single RAT UTRA FDD AAS BS of Local Area BS class shall fulfil minimum requirements for receiver intermodulation specified in 3GPP TS 25.104 [6], subclause 7.6.1.

The single RAT UTRA TDD AAS BS of Wide Area BS class shall fulfil minimum requirements for receiver intermodulation specified in 3GPP TS 25.105 [7], subclause 7.6.1.2.

The single RAT UTRA TDD AAS BS of Local Area BS class shall fulfil minimum requirements for receiver intermodulation specified in 3GPP TS 25.105 [7], subclause 7.6.1.2.

### 7.7.4 Minimum requirement for single RAT E- UTRA operation

The single RAT E-UTRA AAS BS of Wide Area BS class shall fulfil minimum requirements for receiver intermodulation specified in 3GPP TS 36.104 [8], subclause 7.8.

The single RAT E-UTRA AAS BS of Medium Range BS class shall fulfil minimum requirements for receiver intermodulation specified in 3GPP TS 36.104 [8], subclause 7.8.

The single RAT E-UTRA AAS BS of Local Area BS class shall fulfil minimum requirements for receiver intermodulation specified in 3GPP TS 36.104 [8], subclause 7.8.

## 7.8 In-channel selectivity

### 7.8.1 General

In-channel selectivity (ICS) is a measure of the receiver unit ability to receive a wanted signal at its assigned resource block locations in the presence of an interfering signal received at a larger power spectral density. In this condition a throughput requirement shall be met for a specified reference measurement channel. The requirement applies per *TAB connector*.

### 7.8.2 Minimum requirement for MSR operation

For E-UTRA, the minimum requirement for in-channel selectivity is specified in subclause 7.8.4.

For NR, the minimum requirement for in-channel selectivity is specified in 3GPP TS 38.104 [28] for *BS type 1-H* in subclause 7.8.2.

This requirement is not applicable for UTRA operation.

### 7.8.3 Minimum requirement for single RAT UTRA operation

This requirement is not applicable for UTRA BS.

## 7.8.4 Minimum requirement for single RAT E-UTRA operation

The single RAT E-UTRA AAS BS of Wide Area BS class shall fulfil minimum requirements for in-channel selectivity specified in 3GPP TS 36.104 [8], subclause 7.4.1.

The single RAT E-UTRA AAS BS of Medium Range BS class shall fulfil minimum requirements for in-channel selectivity specified in 3GPP TS 36.104 [8], subclause 7.4.1.

The single RAT E-UTRA AAS BS of Local Area BS class shall fulfil minimum requirements for in-channel selectivity specified in 3GPP TS 36.104 [8], subclause 7.4.1.

The interfering signal shall be an E-UTRA signal as specified in 3GPP TS 36.104 [8], annex C and shall be time aligned with the wanted signal.

---

# 8 Performance requirements

## 8.1 General

Performance requirements specify the ability of the AAS BS to correctly demodulate signals in various conditions and configurations.

The demodulation requirements for an AAS BS are the same as *non-AAS BS* demodulation requirements specified for:

- *Single RAT UTRA operation* in TS 25.104 [9] clause 8 for FDD operation, and in TS 25.105 [10] clause 8 for TDD operation,
- *Single RAT E-UTRA operation* in TS 36.104 [11], subclauses 8.2 – 8.4 and 8.6 – 8.7.

### 8.1.1 UTRA operation

Performance requirements for *single RAT UTRA operation* in FDD are specified for the measurement channels defined in 3GPP TS 25.104 [2] and 3GPP TS 25.105 [3]. The requirements only apply to those measurement channels that are supported by AAS BS. For FRC8 in 3GPP TS 25.104 [2] the non E-DPCCH boosting and E-DPCCH boosting requirement only apply for the option supported by the AAS BS. The performance requirements for the high speed train scenarios defined in 3GPP TS 25.104 [2] and 3GPP TS 25.105 [3] are optional.

Unless stated otherwise, performance requirements apply for a single cell only. Performance requirements for an AAS BS supporting UTRA FDD DC-HSUPA or DB-DC-HSUPA and UTRA TDD MC-HSUPA are defined in terms of single carrier requirements. For FDD operation the requirements in clause 8 shall be met with the transmitter unit(s) associated with the *TAB connectors(s)* in the operating band ON.

**NOTE:** In normal operating conditions the *TAB connectors(s)* in UTRA FDD operation are configured to transmit and receive at the same time. The transmitter unit(s) associated with the *TAB connectors* may be OFF for some of the tests as specified in TS 37.145-1 [29] and TS 37.145-2 [30].

In the referred UTRA specifications and in this clause, the term BS with RX diversity refers to performance requirements for two *demodulation branches*, and BS without RX diversity refers to performance requirements for one *demodulation branch*.

For AAS BS with RX diversity, only the BS performance requirements with RX diversity apply, the required  $E_b/N_0$  for UTRA FDD and  $\hat{I}_{or}/I_{oc}$  for UTRA TDD shall be applied separately for each *demodulation branch*.

For AAS BS without RX diversity, only the BS performance requirements without RX diversity apply. The required  $E_b/N_0$  for UTRA FDD and  $\hat{I}_{or}/I_{oc}$  for UTRA TDD shall be applied for each AAS BS *demodulation branch*.

The  $E_b/N_0$  used for UTRA FDD is defined as:

$$E_b / N_o = \frac{E_c}{N_o} \cdot \frac{L_{chip}}{L_{inf}}$$

Where:

$E_c$  is the received total energy of DPDCH, DPCCH, S-DPCCH, HS-DPCCH, E-DPDCH, S-E-DPDCH, E-DPCCH and S-E-DPCCH per PN chip per *demodulation branch* from all branches

$N_o$  is the total one-sided noise power spectral density due to all noise sources

$L_{chip}$  is the number of chips per frame

$L_{inf}$  is the number of information bits in DTCH excluding CRC bits per frame

**Table 8.1.1-1: Summary of AAS BS performance targets for single RAT UTRA operation**

Physical channel	Measurement channel	Static	Multi-path Case 1	Multi-path Case 2	Multi-path Case 3	Moving (NOTE 1)	Birth / Death (NOTE 1)	High Speed Train
		Performance metric						
DCH	12.2 kbps	BLER<10 <sup>-2</sup>	BLER<10 <sup>-2</sup>	BLER<10 <sup>-2</sup>	BLER<10 <sup>-2</sup>	BLER<10 <sup>-2</sup>	BLER<10 <sup>-2</sup>	BLER<10 <sup>-2</sup>
	64 kbps	BLER<10 <sup>-1</sup> ,10 <sup>-2</sup>	BLER<10 <sup>-1</sup> ,10 <sup>-2</sup>	BLER<10 <sup>-1</sup> ,10 <sup>-2</sup>	BLER<10 <sup>-1</sup> ,10 <sup>-2</sup> ,10 <sup>-3</sup>	BLER<10 <sup>-1</sup> ,10 <sup>-2</sup>	BLER<10 <sup>-1</sup> ,10 <sup>-2</sup>	BLER<10 <sup>-1</sup> ,10 <sup>-2</sup> (NOTE 2)
	144 kbps	BLER<10 <sup>-1</sup> ,10 <sup>-2</sup>	BLER<10 <sup>-1</sup> ,10 <sup>-2</sup>	BLER<10 <sup>-1</sup> ,10 <sup>-2</sup>	BLER<10 <sup>-1</sup> ,10 <sup>-2</sup> ,10 <sup>-3</sup>	-	-	
	384 kbps	BLER<10 <sup>-1</sup> ,10 <sup>-2</sup>	BLER<10 <sup>-1</sup> ,10 <sup>-2</sup>	BLER<10 <sup>-1</sup> ,10 <sup>-2</sup>	BLER<10 <sup>-1</sup> ,10 <sup>-2</sup> ,10 <sup>-3</sup>	-	-	

NOTE 1: UTRA FDD only.  
 NOTE 2: UTRA TDD only.  
 NOTE 3: If not stated otherwise, the above performance targets are applicable to UTRA TDD and to UTRA FDD.  
 NOTE 4: In case of multiple BLER level thresholds listed for single requirement and measurement channel combination, those BLER level values are reflected by set multiple requirements in 3GPP TS 25.104 [2], or 3GPP TS 25.105 [3].

### 8.1.2 E-UTRA operation

Performance requirements for the AAS BS are specified for the fixed reference channels (FRC) and propagation conditions defined in 3GPP TS 36.104 [8] annex A and annex B, respectively. The requirements only apply to those FRCs that are supported by the AAS BS.

Unless stated otherwise, performance requirements apply for a single carrier only. Performance requirements for an AAS BS E-UTRA supporting *carrier aggregation* are defined in terms of single carrier requirements. For FDD operation the requirements shall be met with the transmitter unit(s) associated with the *TAB connectors(s)* in the operating band ON.

NOTE: In normal operating conditions *TAB connectors* in FDD operation are configured to transmit and receive at the same time. The transmitter unit(s) associated with the *TAB connectors* may be OFF for some of the tests as specified in TS 37.145-1 [29] and TS 37.145-2 [30].

In the referred E-UTRA specification, the term "RX antennas" refers to *demodulation branches* (and not physical antennas).

The SNR used in this clause is specified based on a single carrier and defined as:

$$SNR = S / N$$

Where:

S is the total signal energy in the subframe on a single *TAB connector*.

N is the noise energy in a bandwidth corresponding to the *transmission bandwidth* over the duration of a subframe.

For *enhanced performance requirements type A* and *type B*, the SINR used in this clause is specified based on a single carrier and defined as:

$$SINR = S/N'$$

Where:

$S$  is the total signal energy of one intra-cell UE in the subframe on a single *TAB connector*.

$N'$  is the summation of the received energy of the strongest inter-cell interferers explicitly defined in a test procedure plus the white noise energy  $N$ , in a bandwidth corresponding to the *transmission bandwidth* over the duration of a subframe on a single *TAB connector*. The respective energy of each inter-cell interferer relative to  $N'$  is defined by its associated DIP value

## 8.2 Minimum requirements for MSR operation

For *single RAT UTRA operation*, minimum requirements for demodulation performance are specified in subclause 8.3.

For *single RAT E-UTRA operation*, minimum requirements for demodulation performance are specified in subclause 8.4.

## 8.3 Minimum requirements for UTRA operation

The *single RAT UTRA operation* in FDD shall fulfil all mandatory BS demodulation performance requirements specified in subclauses 8.2 to 8.12 of 3GPP TS 25.104 [6].

The *single RAT UTRA operation* in TDD shall fulfil all mandatory BS demodulation performance requirements specified in subclauses 8.2 to 8.5 of 3GPP TS 25.105 [7].

In the referred UTRA specifications, the term BS with RX diversity refers to performance requirements for two *demodulation branches*, and BS without RX diversity refers to performance requirements for one *demodulation branch*.

## 8.4 Minimum requirements for E-UTRA operation

The *single RAT E-UTRA operation* shall fulfil all mandatory BS demodulation performance requirements specified in subclauses 8.2 to 8.4 of 3GPP TS 36.104 [8].

In the referred E-UTRA specification, the term "RX antennas" refers to *demodulation branches* (i.e. not physical antennas).

---

# 9 Radiated transmitter characteristics

## 9.1 General

Radiated transmitter characteristics requirements apply on the AAS BS including all its functional components active and for all foreseen modes of operation of the AAS BS unless otherwise stated.

Unless otherwise stated, the transmitter characteristics are specified with a full complement of transceiver units for the configuration in normal operating conditions.

The manufacturer shall declare the minimum number of supported geographical cells (i.e. geographical areas). The minimum number of supported geographical cells ( $N_{\text{cells}}$ ) relates to the AAS BS setting with the minimum amount of cell splitting supported.

*OTA AAS BS* transmitter requirements apply per geographical cell .

Radiated emissions with requirements described as TRP are defined as follows:

$$TRP = \int \int_{4\pi} P_D(r, \theta, \varphi) r^2 \sin(\theta) d\theta d\varphi$$

, where  $P_D(r, \theta, \varphi)$  is the power density in W/m<sup>2</sup> at a distance  $r$  of two orthogonal polarizations.

## 9.2 Radiated transmit power

### 9.2.1 General

An AAS BS is declared to support one or more beams. Radiated transmit power is defined as the EIRP level for a declared beam at a specific *beam peak direction*.

For each beam, the requirement is based on declaration of a beam identity, *reference beam direction pair*, *beamwidth*, *rated beam EIRP*, *OTA peak directions set*, the *beam direction pairs* at the maximum steering directions and their associated *rated beam EIRP* and *beamwidth(s)*.

For a declared beam and *beam direction pair*, the *rated beam EIRP* level is the maximum power that the base station is declared to radiate at the associated *beam peak direction* during the *transmitter ON period*.

For each *beam peak direction* associated with a *beam direction pair* within the *OTA peak directions set*, a specific *rated beam EIRP* level may be claimed. Any claimed value shall be met within the accuracy requirement as described below. *Rated beam EIRP* is only required to be declared for the *beam direction pairs* subject to conformance testing as detailed in TS 37.145-2 [30].

NOTE 1: *OTA peak directions set* is set of *beam peak directions* for which the EIRP accuracy requirement is intended to be met. The *beam peak directions* are related to a corresponding contiguous range or discrete list of *beam centre directions* by the *beam direction pairs* included in the set.

NOTE 2: A *beam direction pair* is data set consisting of the *beam centre direction* and the related *beam peak direction*.

NOTE 3: A declared EIRP value is a value provided by the manufacturer for verification according to the conformance specification declaration requirements, whereas a claimed EIRP value is provided by the manufacturer to the equipment user for normal operation of the equipment and is not subject to formal conformance testing.

### 9.2.2 Minimum requirement for MSR operation

For each declared beam, in normal conditions, for any specific *beam peak direction* associated with a *beam direction pair* within the *OTA peak directions set*, a manufacturer claimed EIRP level in the corresponding *beam peak direction* shall be achievable to within +2,2 dB and -2,2 dB of the claimed value.

For each declared beam, in extreme conditions, for any specific *beam peak direction* associated with a *beam direction pair* within the *OTA peak directions set*, a manufacturer claimed EIRP level in the corresponding *beam peak direction* shall be achievable to within +2,7 dB and -2,7 dB of the claimed value.

In certain regions, the minimum requirement for normal conditions may apply also for some conditions outside the range of conditions defined as normal.

### 9.2.3 Minimum requirement for single RAT UTRA operation

The minimum requirement for UTRA FDD and UTRA TDD 1,28Mcps option carrier radiated transmit power is in each case same as defined in subclause 9.2.2.

### 9.2.4 Minimum requirement for single RAT E-UTRA operation

The minimum requirement for E-UTRA carrier radiated transmit power is same as defined in subclause 9.2.2.

## 9.3 OTA Base Station output power

### 9.3.1 General

The *OTA AAS BS* base station output power is declared as TRP.

### 9.3.2 OTA Maximum output power

#### 9.3.2.1 General

The rated carrier output power of the *OTA AAS BS* shall be as specified for UTRA in table 9.3.2.1-1, and for E-UTRA and NR in table 9.3.2.1-2

**Table 9.3.2.1-1: UTRA OTA AAS Base Station rated output power limits for BS classes**

OTA AAS BS class	$P_{\text{Rated,c,TRP}}$
Wide Area BS	(NOTE)
Medium Range BS	$\leq 44$ dBm
Local Area BS	$\leq 30$ dBm
NOTE: There is no upper limit for the $P_{\text{Rated,c,TRP}}$ of the Wide Area Base Station.	

**Table 9.3.2.1-2: E-UTRA and NR OTA AAS Base Station rated output power limits for BS classes**

OTA AAS BS class	$P_{\text{Rated,c,TRP}}$
Wide Area BS	(NOTE)
Medium Range BS	$\leq 47$ dBm
Local Area BS	$\leq 33$ dBm
NOTE: There is no upper limit for the $P_{\text{Rated,c,TRP}}$ of the Wide Area Base Station.	

#### 9.3.2.2 Minimum requirement for MSR operation

##### 9.3.2.2.1 General

In normal conditions,  $P_{\text{max,c,TRP}}$  shall remain within +2,0 dB and -2,0 dB of the configured carrier TRP as declared by the manufacturer.

In certain regions, the minimum requirement for normal conditions may apply also for some conditions outside the range of conditions defined as normal.

##### 9.3.2.2.2 Additional requirements (regional)

#### 9.3.2.3 Minimum requirement for single RAT UTRA operation

The minimum requirement for single RAT UTRA BS is the same as that defined in subclause 9.3.2.2.

#### 9.3.2.4 Minimum requirement for single RAT E-UTRA operation

##### 9.3.2.4.1 General

The minimum requirement for single RAT E-UTRA BS is the same as that defined in subclause 9.3.2.2.

#### 9.3.2.4.2 Additional requirements (regional)

### 9.3.3 OTA E-UTRA DL RS power

#### 9.3.3.1 General

This requirement applies to the RIB(s) transmitting primary DL RS.

The DL RS power is the resource element power of the Downlink Reference Symbol at the RIB transmitting the DL RS for a cell.

The absolute DL RS power is indicated on the DL-SCH. The absolute accuracy is defined as the maximum deviation between the DL RS power indicated on the DL-SCH and the DL RS power of each E-UTRA carrier.

#### 9.3.3.2 Minimum requirement for MSR operation

There is no DL RS power requirement for UTRA operation.

There is no DL RS power requirement for NR operation.

The minimum requirement for MSR E-UTRA operation is the same as that defined in subclause 9.3.6.4.

#### 9.3.3.3 Minimum requirement for single RAT UTRA operation

There is no DL RS power requirement for UTRA operation.

#### 9.3.3.4 Minimum requirement for single RAT E-UTRA operation

The DL RS power of each E-UTRA carrier shall be within  $\pm 2,1$  dB of the DL RS power indicated on the DL-SCH.

## 9.4 OTA Output power dynamics

### 9.4.1 General

The requirements in subclause 9.4 apply during the *transmitter ON period*. Transmit signal quality (as specified in subclause 9.6) shall be maintained for the output power dynamics requirements. Power control is used to limit the interference level. The TA output power requirements are *single direction requirements* and apply to the *beam peak directions* associated with the *beam direction pairs* over the *OTA peak directions set*.

### 9.4.2 OTA UTRA Inner loop power control in the downlink

#### 9.4.2.1 General

Inner loop power control in the downlink is the ability of the AAS BS transmitter to adjust the transmitter output power of a code channel in accordance with the corresponding TPC symbols received in the uplink.

#### 9.4.2.2 Minimum requirement for MSR operation

For UTRA FDD operation; the minimum requirements for MSR AAS BS inner loop power control in the DL are the same as subclause 9.4.2.3.

This requirement does not apply to E-UTRA operation.

This requirement does not apply to NR operation.

### 9.4.2.3 Minimum requirement for single RAT UTRA operation

For UTRA FDD operation, the Single RAT AAS BS shall have the capability of setting the inner loop *code domain power* on each RIB with a step sizes of 1dB mandatory and 0.5, 1.5, 2.0 dB optional

- a) The tolerance of the power control step due to inner loop power control shall be within the range shown in table 9.4.2.3-1.
- b) The tolerance of the combined output power change due to inner loop power control shall be within the range shown in table 9.4.2.3-2.

**Table 9.4.2.3-1: UTRA FDD power control step tolerance**

Power control commands in the down link	Transmitter power control step tolerance							
	2 dB step size		1,5 dB step size		1 dB step size		0,5 dB step size	
	Lower	Upper	Lower	Upper	Lower	Upper	Lower	Upper
Up (TPC command "1")	+1,0 dB	+3,0 dB	+0,75 dB	+2,25 dB	+0,5 dB	+1,5 dB	+0,25 dB	+0,75 dB
Down (TPC command "0")	-1,0 dB	-3,0 dB	-0,75 dB	-2,25 dB	-0,5 dB	-1,5 dB	-0,25 dB	-0,75 dB

**Table 9.4.2.3-2: UTRA FDD aggregated power control step range**

Power control commands in the down link	Transmitter aggregated power control step change after 10 consecutive equal commands (up or down)							
	2 dB step size		1,5 dB step size		1 dB step size		0,5 dB step size	
	Lower	Upper	Lower	Upper	Lower	Upper	Lower	Upper
Up (TPC command "1")	+16 dB	+24 dB	+12 dB	+18 dB	+8 dB	+12 dB	+4 dB	+6 dB
Down (TPC command "0")	-16 dB	-24 dB	-12 dB	-18 dB	-8 dB	-12 dB	-4 dB	-6 dB

### 9.4.2.4 Minimum requirement for single RAT E-UTRA operation

This requirement does not apply to E-UTRA operation.

## 9.4.3 OTA Power control dynamic range

### 9.4.3.1 General

The power control dynamic range is the difference between the maximum and the minimum *code domain power* of a code channel for a specified reference condition.

This requirement applies at each RIB supporting transmission in the operating band.

This requirement applies to UTRA operation only.

### 9.4.3.2 Minimum requirement for MSR operation

For UTRA FDD operation; the minimum requirements for MSR AAS BS power control dynamic range are the same as subclause 9.4.3.3

This requirement does not apply to E-UTRA operation.

This requirement does not apply to NR operation.

### 9.4.3.3 Minimum requirement for single RAT UTRA operation

Down link (DL) power control dynamic range shall be:

Maximum *code domain power*:  $P_{\max,c,TRP} - 3$  dB or greater

Minimum *code domain power*:  $P_{\max,c,TRP} - 28$  dB or less

#### 9.4.3.4 Minimum requirement for single RAT E-UTRA operation

This requirement does not apply to E-UTRA operation.

### 9.4.4 OTA Total power dynamic range

#### 9.4.4.1 General

The total power dynamic range is the difference between the maximum and the minimum output power for a specified reference condition.

This requirement applies at each RIB supporting transmission in the operating band.

NOTE 1: The upper limit of the dynamic range is the BS maximum output power ( $P_{\text{Rated,c,TRP}}$ ). The lower limit of the dynamic range is the lowest minimum power from the AAS BS when no traffic channels are activated.

Particularly for E-UTRA, the total power dynamic range is the difference between the maximum and the minimum transmit power of an OFDM symbol for a specified reference condition.

NOTE 2: The upper limit of the dynamic range at a RIB is the OFDM symbol power at maximum output power ( $P_{\text{Rated,c,TRP}}$ ) when transmitting on all RBs. The lower limit of the dynamic range at a RIB is the OFDM symbol power when one resource block is transmitted. The OFDM symbol carries PDSCH or sPDSCH and not contain RS, PBCH or synchronization signals.

#### 9.4.4.2 Minimum requirement for MSR operation

For UTRA FDD operation; the minimum requirements for MSR AAS BS total power dynamic range are the same as subclause 9.4.4.3.

For E-UTRA operation; the minimum requirements for MSR AAS BS total power dynamic range are the same as subclause 9.4.4.4.

For NR operation, the minimum requirements for MSR AAS BS total power dynamic range are the same as those for *BS type 1-O* in TS 38.104 [28] subclause 9.4.3.2.

#### 9.4.4.3 Minimum requirement for single RAT UTRA operation

The downlink (DL) total power dynamic range shall be 18 dB or greater.

#### 9.4.4.4 Minimum requirement for single RAT E-UTRA operation

The downlink (DL) total power dynamic range for each E-UTRA carrier shall be larger than or equal to the level in table 9.4.4.4-1.

**Table 9.4.4.4-1: E-UTRA BS total power dynamic range**

E-UTRA channel bandwidth [MHz]	Total power dynamic range (dB)
1.4	7.7
3	11.7
5	13.9
10	16.9
15	18.7
20	20

The requirement does not apply to Band 46 nor Band 49.

## 9.4.5 OTA IPDL time mask

### 9.4.5.1 General

To support IPDL location method in UTRA FDD operation, the AAS BS shall interrupt all transmitted signals in the downlink (i.e. common and dedicated channels). The IPDL time mask specifies the limits at the RIB output power during these idle periods.

This requirement applies only to AAS BS supporting IPDL. The requirement applies at each RIB supporting transmission in the operating band.

### 9.4.5.2 Minimum requirement for MSR operation

For UTRA FDD operation; the minimum requirement for MSR AAS BS IPDL time mask is the same as subclause 9.4.5.3.

This requirement does not apply to E-UTRA operation.

This requirement does not apply to NR operation.

### 9.4.5.3 Minimum requirement for single RAT UTRA operation

The mean power measured over a period starting 27 chips after the beginning of the IPDL period and ending 27 chips before the expiration of the IPDL period shall be equal to or less than

$$P_{\max,c,TRP} - 35 \text{ dB}$$

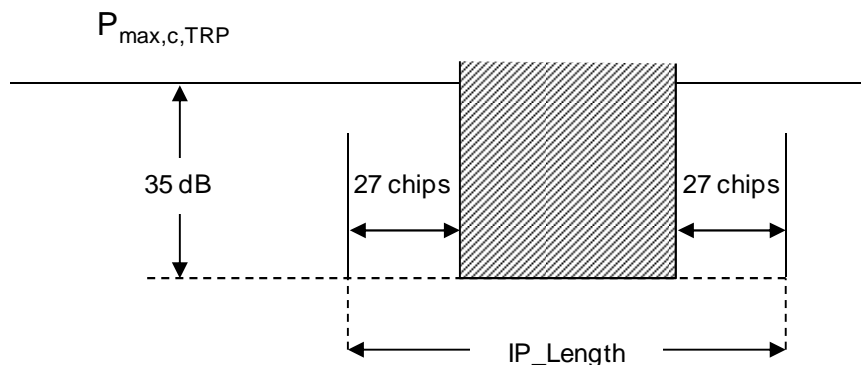

**Figure 9.4.5.3-1: IPDL Time Mask**

The requirement applies to all output powers within the total power dynamic range as specified in subclause 9.4.4.

### 9.4.5.4 Minimum requirement for single RAT E-UTRA operation

This requirement does not apply to E-UTRA operation.

## 9.4.6 OTA RE Power control dynamic range

### 9.4.6.1 General

The RE power control dynamic range is the difference between the power of an RE and the average RE power for an AAS BS at maximum output power ( $P_{\text{Rated},c,TRP}$ ) for a specified reference condition.

This requirement applies at each RIB supporting transmission in the operating band.

### 9.4.6.2 Minimum requirement for MSR operation

This requirement does not apply to UTRA operation.

For E-UTRA operation; the minimum requirements for MSR AAS BS RE power control dynamic range are the same as in subclause 9.4.6.4.

For NR operation, the minimum requirements for MSR AAS BS RE power control dynamic range are the same as those for *BS type 1-O* in TS 38.104 [28] subclause 9.4.2.2.

### 9.4.6.3 Minimum requirement for single RAT UTRA operation

This requirement does not apply to UTRA operation.

### 9.4.6.4 Minimum requirement for single RAT E-UTRA operation

The RE power control dynamic range is specified in table 9.4.6.4-1.

**Table 9.4.6.4-1: E-UTRA BS RE power control dynamic range**

Modulation scheme used on the RE	RE power control dynamic range (dB)	
	(down)	(up)
QPSK (PDCCH)	-6	+4
QPSK (PDSCH)	-6	+3
QPSK (sPDCCH)	-6	+4
QPSK (sPDSCH)	-6	+3
16QAM (PDSCH)	-3	+3
16QAM (sPDSCH)	-3	+3
64QAM (PDSCH)	0	0
64QAM (sPDSCH)	0	0
256QAM (PDSCH)	0	0
1024QAM (PDSCH)	0	0

NOTE: The output power per carrier ( $P_{\text{Rated,c,TRP}}$ ) shall always be less or equal to the maximum output power of the base station ( $P_{\text{Rated,t,TRP}}$ ).

## 9.5 OTA Transmit ON/OFF power

### 9.5.1 General

OTA transmitter ON/OFF power requirements apply only to TDD operation of E-UTRA.

The OTA Transmit ON/OFF power requirements are co-location requirements and specified as the power sum of the supported polarization(s) at the *co-location reference* antenna conducted output(s).

### 9.5.2 OTA Transmitter OFF power

#### 9.5.2.1 General

OTA transmitter OFF power is defined as the mean power measured over  $70/N$   $\mu\text{s}$  filtered with a square filter of bandwidth equal to the *Base Station RF Bandwidth(s)* centred on the central frequency of the *Base Station RF Bandwidth (s)* during the *transmitter OFF period*.  $N$  is equal to 1 for UTRA and E\_UTRA SCS/15 for NR, where SCS is Sub Carrier Spacing in kHz.

For *multi-band RIBs* and *single band RIBs* supporting transmission in multiple bands, the requirement is only applicable during the *transmitter OFF period* in all supported operating bands.

For AAS BS supporting intra-band contiguous CA, the transmitter OFF power is defined as the mean power measured over  $70/N$   $\mu\text{s}$  filtered with a square filter of bandwidth equal to the *Aggregated BS Channel Bandwidth*  $BW_{\text{Channel\_CA}}$  centred on  $(F_{\text{edge,high}}+F_{\text{edge,low}})/2$  during the *transmitter OFF period*.  $N$  is equal to 1 if there are any UTRA or E-UTRA

carriers, or for NR  $N = \text{SCS}/15$ , where SCS is the smallest supported Sub Carrier Spacing in kHz in the *Aggregated BS Channel Bandwidth*.

### 9.5.2.2 Minimum requirement for MSR operation

There is no OTA transmitter OFF power requirement for UTRA operation.

For NR and E-UTRA operation, the total power from all *co-location reference antenna* conducted output(s) shall be less than -106 dBm/MHz.

### 9.5.2.3 Minimum requirement for single RAT UTRA operation

There is no OTA transmitter OFF power requirement for UTRA operation.

### 9.5.2.4 Minimum requirement for single RAT E-UTRA operation

The total power from all *co-location reference antenna* conducted output(s) shall be less than -106 dBm/MHz.

## 9.5.3 OTA Transmitter transient period

### 9.5.3.1 General

The OTA *transmitter transient period* is the time period during which the transmitter unit is changing from the OFF period to the ON period or vice versa. The OTA *transmitter transient period* is illustrated in figure 9.5.3.1-1.

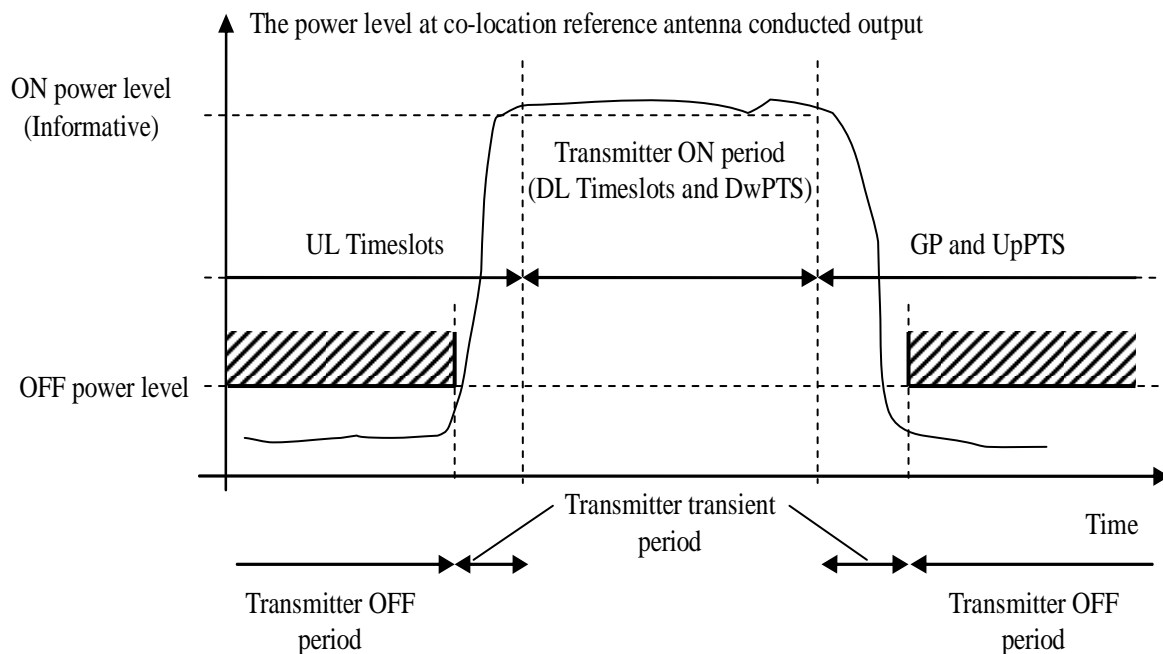

**Figure 9.5.3.1-1: Illustration of the relations of *transmitter ON period*, *transmitter OFF period* and *transmitter transient period***

This requirement applies at each *co-location reference antenna* conducted output supporting transmission in the operating band.

### 9.5.3.2 Minimum requirement for MSR operation

For E-UTRA operation, the minimum requirements for MSR AAS BS OTA *transmitter transient period* shall be shorter than the values in table 9.5.3.4-1.

For NR operation, the minimum requirements for MSR AAS BS OTA transmitter transient period shall be shorter than the values specified in 3GPP TS 37.104 [5] subclause 6.4.2.1.

### 9.5.3.3 Minimum requirement for single RAT UTRA operation

There is no OTA Transmitter transient period requirement for UTRA operation.

### 9.5.3.4 Minimum requirement for single RAT E-UTRA operation

For single RAT AAS BS, the OTA transmitter transient period shall be shorter than the values in table 9.5.3.4-1.

**Table 9.5.3.4-1: Minimum requirements for the transmitter transient period**

Transition	Transient period length [us]
OFF to ON	17
ON to OFF	17

## 9.6 OTA Transmitted signal quality

### 9.6.1 General

Unless otherwise stated, the requirements in clause 9.6 apply during the transmitter ON period.

### 9.6.2 OTA Frequency Error

#### 9.6.2.1 General

OTA frequency error is the measure of the difference between the actual AAS BS transmit frequency and the assigned frequency. The same source shall be used for RF frequency and data clock generation.

The OTA frequency error requirement is defined as a *single direction requirement* at the RIB and shall be met within the OTA coverage range.

#### 9.6.2.2 Minimum requirement for MSR operation

The minimum requirement for a UTRA OTA frequency error is the same as defined in subclause 9.6.2.3.

The minimum requirement for an E-UTRA OTA frequency error is the same as defined in subclause 9.6.2.4.

The minimum requirement for an NR OTA frequency error is the same as that for BS type 1-O defined in 3GPP TS 38.104 [28] subclause 9.6.1.2.

#### 9.6.2.3 Minimum requirement for single RAT UTRA operation

The single RAT UTRA FDD AAS BS of wide area BS class shall fulfil the frequency error minimum requirements for wide area BS described in 3GPP TS 25.104 [6], subclause 6.3.1.

The single RAT UTRA FDD AAS BS of medium range BS class shall fulfil the frequency error minimum requirements for medium range BS described in 3GPP TS 25.104 [6], subclause 6.3.1.

The single RAT UTRA FDD AAS BS of local area BS class shall fulfil the frequency error minimum requirements for local area BS described in 3GPP TS 25.104 [6], subclause 6.3.1.

#### 9.6.2.4 Minimum requirement for single RAT E-UTRA operation

The single RAT E-UTRA AAS BS of wide area BS class shall fulfil the frequency error minimum requirements for wide area BS described in 3GPP TS 36.104 [8], subclause 6.5.1.1.

The single RAT E-UTRA AAS BS of medium range BS class shall fulfil the frequency error minimum requirements for medium range BS described in 3GPP TS 36.104 [8], subclause 6.5.1.1.

The single RAT E-UTRA AAS BS of local area BS class shall fulfil the frequency error minimum requirements for local area BS described in 3GPP TS 36.104 [8], subclause 6.5.1.1.

### 9.6.3 OTA Time alignment error

#### 9.6.3.1 General

This requirement applies to frame timing in:

- UTRA single/multi-carrier transmissions and their combinations with MIMO or TX diversity.
- E-UTRA single/multi-carrier transmissions and their combinations with MIMO or TX diversity.
- E-UTRA *carrier aggregation*, with or without MIMO or TX diversity.
- NR single/multi-carrier transmissions, and their combinations with MIMO.
- NR Carrier Aggregation, with or without MIMO.

Frames of the WCDMA/LTE/NR signals present in the radiated domain are not perfectly aligned in time. In relation to each other, the RF signals present in the radiated domain may experience certain timing differences.

For a specific set of signals/transmitter configuration/transmission mode, the OTA Time Alignment Error (OTA TAE) is defined as the largest timing difference between any two different E-UTRA signals or any two different UTRA signals or any two different NR signals belonging to different *reference symbols* (e.g. *CRS0* or *CRS1* for E-UTRA, *PDSCH DMRS on ports 1000 and 1001* for NR) in the radiated domain. The OTA time alignment error requirement is defined as a *single direction requirement* at the RIB and shall be met within the *OTA coverage range*.

#### 9.6.3.2 Minimum requirement for MSR operation

The minimum requirement for a UTRA time alignment error is the same as defined in subclause 9.6.3.3.

The minimum requirement for an E-UTRA time alignment error is the same as defined in subclause 9.6.3.4.

The minimum requirement for an NR time alignment error is the same as that for *BS type 1-0* defined in 3GPP TS 38.104 [28] subclause 9.6.3.2.

#### 9.6.3.3 Minimum requirement for single RAT UTRA operation

This requirement applies to frame timing in Tx diversity, MIMO transmission, DC-HSDPA, DB-DC-HSDPA, 4C-HSDPA, NC-4C-HSDPA, 8C-HSDPA and their combinations.

The OTA TAE between any two reference symbols shall not exceed the specified minimum requirements described in 3GPP TS 25.104 [6], subclause 6.8.4.1.

#### 9.6.3.4 Minimum requirement for single RAT E-UTRA operation

This requirement applies to frame timing in TX diversity, MIMO transmission, *carrier aggregation* and their combinations.

The OTA TAE between any two reference symbols shall not exceed the specified minimum requirements described in 3GPP TS 36.104 [8], subclause 6.5.3.1.

## 9.6.4 OTA Modulation quality

### 9.6.4.1 General

OTA modulation quality is defined by the difference between the measured carrier signal and a reference signal. Modulation quality can be expressed e.g. as Peak Code Domain Error (PCDE) or Relative Code Domain Error (RCDE) or Error Vector Magnitude (EVM) for UTRA and Error Vector Magnitude (EVM) for E-UTRA.

The OTA modulation quality requirement is defined as a *single direction requirement* at the RIB and shall be met within the *OTA coverage range*.

### 9.6.4.2 Minimum requirement for MSR operation

The minimum requirement for a UTRA modulation quality are defined in subclause 9.6.4.3.

The minimum requirement for an E-UTRA modulation quality are defined in subclause 9.6.4.4.

The minimum requirement for an NR modulation quality is the same as that for *BS type 1-O* defined in 3GPP TS 38.104 [28] in subclause 9.6.2.2.

### 9.6.4.3 Minimum requirement for single RAT UTRA operation

The Error Vector Magnitude is a measure of the difference between the ideal waveform and the measured waveform. This difference is called the error vector. Both waveforms pass through a matched Root Raised Cosine filter to the considered chip rate and roll-off  $\alpha=0.22$ . Both waveforms are then further modified by selecting the frequency, absolute phase, absolute amplitude and chip clock timing to minimize the error vector. The EVM result is defined as the square root of the ratio of the mean error vector power to the mean reference power expressed as a percentage.

For UTRA FDD the measurement interval is one timeslot as defined by the C-PICH (when present) otherwise the measurement interval is one timeslot starting with the beginning of the SCH. The requirement is valid over the total power dynamic range as specified in subclause 9.4.4. The minimum requirements are the same as those in 3GPP TS 25.104 [6], subclause 6.8.2.1.

For UTRA FDD the Peak Code Domain Error is computed by projecting the error vector onto the code domain at a specified spreading factor. The Code Domain Error for every code in the domain is defined as the ratio of the mean power of the projection onto that code, to the mean power of the composite ideal waveform. This ratio is expressed in dB. The Peak Code Domain Error is defined as the maximum value for the Code Domain Error for all codes. The measurement interval is one timeslot as defined by the C-PICH (when present) otherwise the measurement interval is one timeslot starting with the beginning of the SCH. The minimum requirements are the same as those in 3GPP TS 25.104 [6], subclause 6.8.3.1.

For UTRA FDD the Relative Code Domain Error is computed by projecting the error vector onto the code domain at a specified spreading factor. Only the active code channels in the composite ideal waveform are considered for this requirement. The Relative Code Domain Error for every active code is defined as the ratio of the mean power of the error projection onto that code, to the mean power of the active code in the composite ideal waveform. This ratio is expressed in dB. The measurement interval is one frame. The minimum requirements are the same as those in 3GPP TS 25.104 [6], subclause 6.8.5.1.

The requirement for Relative Code Domain Error is only applicable for 64QAM modulated codes.

### 9.6.4.4 Minimum requirement for single RAT E-UTRA operation

For E-UTRA, the minimum requirement for modulation quality, EVM, is specified in 3GPP TS 36.104 [8], subclause 6.5.2.

## 9.6.5 OTA Transmit pulse shape filter

### 9.6.5.1 General

Transmit pulse shape filter for *single RAT UTRA operation* in FDD and for *MSR operation* in UTRA FDD is defined in 3GPP TS 25.104 [6] subclause 6.8.1.

Transmit pulse shape filter is not defined for a *single RAT E-UTRA operation*, nor for *MSR operation* using E-UTRA and/or NR.

## 9.7 OTA Unwanted Emissions

### 9.7.1 General

Unwanted emissions consist of so-called out-of-band emissions and spurious emissions according to ITU definitions 3GPP TS 25.331 [16]. In ITU terminology, out of band emissions are unwanted emissions immediately outside the *channel bandwidth* resulting from the modulation process and non-linearity in the transmitter but excluding spurious emissions. Spurious emissions are emissions which are caused by unwanted transmitter effects such as harmonics emission, parasitic emission, intermodulation products and frequency conversion products, but exclude out of band emissions.

OTA unwanted emissions for *OTA AAS BS* in *single RAT E-UTRA operation* and *MSR operation* using E-UTRA consist of an OTA operating band unwanted emissions requirement and OTA spurious emissions requirement. OTA operating band unwanted emissions requirement defines limits for emissions in each supported *downlink operating band* plus the frequency ranges  $\Delta f_{\text{OBUE}}$  above and  $\Delta f_{\text{OBUE}}$  below each band, where  $\Delta f_{\text{OBUE}}$  is the maximum offset of the operating band unwanted emission mask from the operating band edge. Emissions outside of this frequency range are limited by OTA spurious emissions requirement.

The values of  $\Delta f_{\text{OBUE}}$  are defined for *OTA AAS BS* for E-UTRA and UTRA operating bands in Table 9.7.1-1.

**Table 9.7.1-1: Maximum offset of OBUE outside the downlink operating band**

BS type	Operating band characteristics	$\Delta f_{\text{OBUE}}$ [MHz]
OTA AAS BS	$F_{\text{DL\_high}} - F_{\text{DL\_low}} < 100$ MHz	10
	$100 \text{ MHz} \leq F_{\text{DL\_high}} - F_{\text{DL\_low}} \leq 900$ MHz	40

OTA unwanted emissions for *OTA AAS BS* in *single UTRA operation* and *MSR operation* using UTRA consist of OTA spectrum emission mask requirement and OTA spurious emissions requirement.

NOTE: for definitions of conducted unwanted emissions requirements refer to clause 6.6

The unwanted emission requirements are applied per cell for all the configurations supported by *OTA AAS BS*. Requirements for OTA unwanted emissions are captured using TRP, *single direction requirements* or *co-location requirements* as described per requirement.

There is in addition a requirement for occupied bandwidth and an ACLR requirement.

### 9.7.2 OTA occupied bandwidth

#### 9.7.2.1 General

The OTA occupied bandwidth is the width of a frequency band such that, below the lower and above the upper frequency limits, the mean powers emitted are each equal to a specified percentage  $\beta/2$  of the total mean transmitted power. See also recommendation ITU-R SM.328 [17].

The value of  $\beta/2$  shall be taken as 0.5%.

The OTA occupied bandwidth requirement applies during the *transmitter ON period* for a single transmitted carrier. The minimum requirement below may be applied regionally. There may also be regional requirements to declare the OTA occupied bandwidth according to the definition in the present clause.

The OTA occupied bandwidth is defined as a *single direction requirement* and shall be met in the manufacturer's declared *OTA coverage range* at the RIB.

### 9.7.2.2 Minimum requirement for MSR operation

For AAS BS in MSR operation, the minimum requirement for OTA occupied bandwidth is the same as that stated in 3GPP TS 37.104 [9], subclause 6.6.3.

### 9.7.2.3 Minimum requirement for single RAT UTRA operation

For AAS BS in *single RAT UTRA operation FDD*, the minimum requirement for OTA occupied bandwidth is the same as that stated in 3GPP TS 25.104 [6] subclause 6.6.1.

### 9.7.2.4 Minimum requirement for single RAT E-UTRA operation

For AAS BS in *single RAT E-UTRA operation*, the minimum requirement for OTA occupied bandwidth is the same as that stated in 3GPP TS 36.104 [8], subclause 6.6.1.

## 9.7.3 OTA Adjacent Channel Leakage power Ratio

### 9.7.3.1 General

OTA Adjacent Channel Leakage power Ratio (ACLR) is the ratio of the filtered mean power centred on the assigned channel frequency to the filtered mean power centred on an adjacent channel frequency. The measured power is TRP.

### 9.7.3.2 Minimum requirement for MSR operation

For AAS BS in *MSR operation* using E-UTRA, the OTA ACLR limits for AAS BS are the same as those specified in 3GPP TS 37.104 [9] subclauses 6.6.4.1. The ACLR absolute limits in 3GPP TS 37.104 [9] subclauses 6.6.4.1 are replaced with the following:

- For E-UTRA or NR Category A AAS BS of Wide Area BS class the OTA ACLR absolute limit of -4dBm/MHz shall apply,
- For E-UTRA or NR Category B AAS BS Wide Area BS class the OTA ACLR absolute limit of -6dBm/MHz shall apply.
- For E-UTRA or NR AAS BS of Medium Range BS class the OTA ACLR absolute limit of -16 dBm/MHz shall apply.
- For E-UTRA or NR AAS BS of Local Area BS class the OTA ACLR absolute limit of -23dBm/MHz shall apply.

The OTA ACLR limit or the ACLR absolute limit of AAS BS, whichever is less stringent, shall apply outside the *Base Station RF Bandwidth* or *Radio Bandwidth*.

For AAS BS in *MSR operation* using UTRA FDD, the minimum requirement for OTA ACLR are the same as those specified in 3GPP TS 25.104 [6], subclause 6.6.2.2, where the ACLR absolute limit is replaced with the following:

- For UTRA FDD Category A AAS BS of Wide Area BS class the OTA ACLR absolute limit of -7dBm/MHz shall apply.
- For UTRA FDD Category B AAS BS Wide Area BS class the OTA ACLR absolute limit of -9dBm/MHz shall apply.
- For E-UTRA FDD AAS BS of Medium Range BS class the OTA ACLR absolute limit of -19 dBm/MHz shall apply.
- For E-UTRA FDD AAS BS of Local Area BS class the OTA ACLR absolute limit of -26dBm/MHz shall apply.

The OTA ACLR limit or the ACLR absolute limit of AAS BS, whichever is less stringent, shall apply outside the *Base Station RF Bandwidth* or *Radio Bandwidth*.

For a RIB supporting operation in *non-contiguous spectrum*, the OTA ACLR requirement also applies for the first adjacent channel inside any *sub-block gap* with a gap size  $W_{\text{gap}} \geq 15\text{MHz}$ . The OTA ACLR requirement for the second adjacent channel applies inside any *sub-block gap* with a gap size  $W_{\text{gap}} \geq 20\text{MHz}$ .

OTA CACLR requirements apply in *sub-block gaps* as defined in 3GPP TS 37.104 [9], subclause 6.6.4.4. Either the OTA CACLR limit or the OTA ACLR absolute limit of AAS BS shall apply, whichever is less stringent.

For a *multi-band RIB*, the OTA ACLR requirement also applies for the first adjacent channel inside any *Inter RF Bandwidth gap* with a gap size  $W_{\text{gap}} \geq 15\text{MHz}$ . The OTA ACLR requirement for the second adjacent channel applies inside any *Inter RF Bandwidth gap* with a gap size  $W_{\text{gap}} \geq 20\text{MHz}$ .

OTA CACLR requirements apply in *Inter RF Bandwidth gaps* as defined in 3GPP TS 37.104 [9], subclause 6.6.4.4. Either the OTA CACLR limit or the OTA ACLR absolute limit of AAS BS shall apply, whichever is less stringent.

### 9.7.3.3 Minimum requirement for single RAT UTRA operation

For AAS BS in *single RAT UTRA operation FDD*, the OTA ACLR minimum requirements are the same as those specified in 3GPP TS 25.104 [6], subclauses 6.6.2.2.1, where the ACLR absolute limit is replaced with the following:

- For UTRA FDD Category A AAS BS of Wide Area BS class the OTA ACLR absolute limit of -7dBm/MHz shall apply.
- For UTRA FDD Category B AAS BS Wide Area BS class the OTA ACLR absolute limit of -9dBm/MHz shall apply.
- For UTRA FDD AAS BS of Medium Range BS class the OTA ACLR absolute limit of -19 dBm/MHz shall apply.
- For UTRA FDD AAS BS of Local Area BS class the OTA ACLR absolute limit of -26dBm/MHz shall apply.

The OTA ACLR limits or the absolute ACLR limits apply whichever is less stringent.

For AAS BS in *single RAT UTRA operation FDD*, the OTA CACLR limits are the same as those specified in 3GPP TS 25.104 [6], subclauses 6.6.2.2.2. The ACLR absolute limit of AAS BS is replaced with the following:

- For UTRA FDD Category A AAS BS of Wide Area BS class the OTA ACLR absolute limit of -7dBm/MHz shall apply.
- For UTRA FDD Category B AAS BS Wide Area BS class the OTA ACLR absolute limit of -9dBm/MHz shall apply.
- For UTRA FDD AAS BS of Medium Range BS class the OTA ACLR absolute limit of -19 dBm/MHz shall apply.
- For UTRA FDD AAS BS of Local Area BS class the OTA ACLR absolute limit of -26dBm/MHz shall apply.

The OTA CACLR limit or the OTA ACLR absolute limit of AAS BS shall apply, whichever is less stringent.

### 9.7.3.4 Minimum requirement for single RAT E-UTRA operation

For AAS BS in *single RAT E-UTRA operation*, the OTA ACLR and OTA CACLR limits are the same as those specified in 3GPP TS 36.104 [8], subclauses 6.6.2.1 and 6.6.2.2. The ACLR absolute limits in 3GPP TS 36.104 [8] subclauses 6.6.2.1 and 6.6.2.2 are replaced with the following:

- For E-UTRA Category A AAS BS of Wide Area BS class the ACLR absolute limit of -4dBm/MHz shall apply.
- For E-UTRA Category B AAS BS Wide Area BS class the ACLR absolute limit of -6dBm/MHz shall apply.
- For E-UTRA AAS BS of Medium Range BS class the ACLR absolute limit of -16 dBm/MHz shall apply.
- For E-UTRA AAS BS of Local Area BS class the ACLR absolute limit of -23dBm/MHz shall apply.

The OTA ACLR (CACLR) limit or the ACLR absolute limit of AAS BS shall apply, whichever is less stringent.

## 9.7.4 OTA Spectrum emission mask

### 9.7.4.1 General

This requirement is applicable for single RAT UTRA AAS BS operation only.

The spectrum emission mask minimum requirements are quoted as TRP unless otherwise stated.

### 9.7.4.2 Minimum requirement for MSR operation

There is no spectrum emission mask requirement for an MSR AAS BS.

### 9.7.4.3 Minimum requirement for single RAT UTRA operation

#### 9.7.4.3.1 General

The spectrum emission mask requirements for a UTRA single RAT AAS BS is based upon the minimum requirement as specified in 3GPP TS 25.104 [2] or TS 25.105 [7], and for each RIB the emissions shall not exceed an AAS BS minimum requirement specified as  $10\log_{10}(4)$ .

NOTE: Conformance to the AAS BS spectrum emission mask requirement can be demonstrated by meeting the spectrum emission mask power at each RIB shall be less than or equal to the AAS BS limit as defined in this subclause for the respective frequency span, by  $-10\log_{10}(4)$

#### 9.7.4.3.2 Minimum requirements for single RAT UTRA FDD operation

The minimum requirement is specified in table's 9.7.4.3.2-1 to 9.7.3.4.2-10 for the appropriate  $P_{\max,c,TRP}$ , where:

- $\Delta f$  is the separation between the carrier frequency and the nominal -3 dB point of the measuring filter closest to the carrier frequency.
- $f_{\text{offset}}$  is the separation between the carrier frequency and the centre of the measurement filter;
- $f_{\text{offset,max}}$  is either 12.5 MHz or the offset to the UMTS Tx band edge as defined in clause 5.2, whichever is the greater.
- $\Delta f_{\text{max}}$  is equal to  $f_{\text{offset,max}}$  minus half of the bandwidth of the measuring filter.

Inside any *Inter RF Bandwidth gaps* with  $W_{\text{gap}} < 2 \times \Delta f_{\text{OBUE}}$  for a *multi-band RIB*, emissions shall not exceed the cumulative sum of the *minimum requirements* specified at the *Base Station RF Bandwidth edges* on each side of the *Inter RF Bandwidth gap*. The *minimum requirements* for *Base Station RF Bandwidth edge* is specified in tables 9.7.3.4.2-1 to 9.7.3.4.2-10 below, where in this case:

- $\Delta f$  is equal to 2.5MHz plus the separation between the *Base Station RF Bandwidth edge* frequency and the nominal -3dB point of the measuring filter closest to the *Base Station RF Bandwidth edge*.
- $f_{\text{offset}}$  is equal to 2.5MHz plus the separation between the *Base Station RF Bandwidth edge* frequency and the centre of the measuring filter.
- $f_{\text{offset,max}}$  is either 12.5 MHz or the offset to the UMTS Tx band edge as defined in clause 5.2, whichever is the greater.
- $\Delta f_{\text{max}}$  is equal to  $f_{\text{offset,max}}$  minus half of the bandwidth of the measuring filter.

For a *multi-band RIB*, the operating band unwanted emission minimum requirements apply also in a supported operating band without any carrier transmitted, in the case where there are carrier(s) transmitted in another supported operating band. In this case, no cumulative limit is applied in the *inter-band gap* between a supported *downlink operating band* with carrier(s) transmitted and a supported *downlink operating band* without any carrier transmitted and

- In case the *inter-band gap* between a downlink band with carrier(s) transmitted and a downlink band without any carrier transmitted is less than  $2 \times \Delta f_{\text{OBUE}}$ ,  $f_{\text{offset,max}}$  shall be the offset to the frequency  $\Delta f_{\text{OBUE}}$  outside the outermost edges of the two *downlink operating bands* and the operating band unwanted emission limit of the

band where there are carriers transmitted, as defined in the tables of the present subclause, shall apply across both downlink bands.

- In other cases, the operating band unwanted emission limit of the band where there are carriers transmitted, as defined in the tables of the present subclause for the largest frequency offset ( $\Delta f_{max}$ ), shall apply from  $\Delta f_{OBUE}$  below the lowest frequency, up to  $\Delta f_{OBUE}$  above the highest frequency of the *downlink operating band* without any carrier transmitted.

Inside any *sub-block gap* for a RIB operating in *non-contiguous spectrum*, emissions shall not exceed the cumulative sum of the *minimum requirements* specified for the adjacent sub blocks on each side of the *sub-block gap*. The *minimum requirement* for each sub block is specified in tables 9.7.4.3.2-1 to 9.7.4.3.2-10 below, where in this case:

- $\Delta f$  is equal to 2.5MHz plus the separation between the sub block edge frequency and the nominal -3 dB point of the measuring filter closest to the sub block edge.
- $f_{offset}$  is equal to 2.5MHz plus the separation between the sub block edge frequency and the centre of the measuring filter.
- $f_{offset_{max}}$  is equal to the *sub-block gap* bandwidth minus half of the bandwidth of the measuring filter plus 2.5MHz.
- $\Delta f_{max}$  is equal to  $f_{offset_{max}}$  minus half of the bandwidth of the measuring filter.

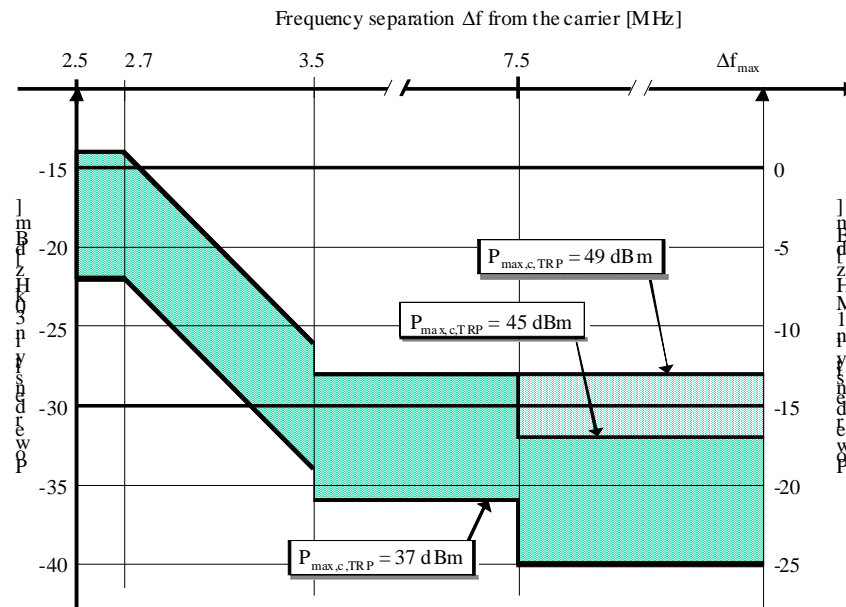

**Illustrative diagram of spectrum emission mask**

**Figure 9.7.4.3.2-1: Spectrum emission mask**

Table 9.7.4.3.2-1: Spectrum emission mask values,  $P_{\text{rated,c,TRP}} \geq 49$  dBm for UTRA FDD

Frequency offset of measurement filter -3 dB point, $\Delta f$	Frequency offset of measurement filter centre frequency, $f_{\text{offset}}$	Minimum requirement (NOTE 1, 2)	Measurement bandwidth (NOTE 4)
$2.5 \text{ MHz} \leq \Delta f < 2.7 \text{ MHz}$	$2.515 \text{ MHz} \leq f_{\text{offset}} < 2.715 \text{ MHz}$	-8 dBm	30 kHz
$2.7 \text{ MHz} \leq \Delta f < 3.5 \text{ MHz}$	$2.715 \text{ MHz} \leq f_{\text{offset}} < 3.515 \text{ MHz}$	$-8 \text{ dBm} - 15 \cdot \left( \frac{f_{\text{offset}}}{\text{MHz}} - 2.715 \right) \text{ dB}$	30 kHz
(NOTE 3)	$3.515 \text{ MHz} \leq f_{\text{offset}} < 4.0 \text{ MHz}$	-20 dBm	30 kHz
$3.5 \text{ MHz} \leq \Delta f < 7.5 \text{ MHz}$	$4.0 \text{ MHz} \leq f_{\text{offset}} < 8.0 \text{ MHz}$	-7 dBm	1 MHz
$7.5 \text{ MHz} \leq \Delta f \leq \Delta f_{\text{max}}$	$8.0 \text{ MHz} \leq f_{\text{offset}} < f_{\text{offset}_{\text{max}}}$	-7 dBm	1 MHz

NOTE 1: For a RIB supporting *non-contiguous spectrum* operation the *minimum requirement* within *sub-block gaps* within any operating band is calculated as a cumulative sum of contributions from adjacent sub blocks on each side of the *sub-block gap*, where the contribution from the far-end sub-block shall be scaled according to the measurement bandwidth of the near-end sub-block. Exception is  $\Delta f \geq 12.5 \text{ MHz}$  from both adjacent sub blocks on each side of the *sub-block gap*, where the spurious emission *minimum requirements* in subclause 9.7.6 shall be met.

NOTE 2: For a *multi-band RIB* with *Inter RF Bandwidth gap*  $< 2 \times \Delta f_{\text{OBUE}}$  the *minimum requirement* within the *Inter RF Bandwidth gaps* is calculated as a cumulative sum of contributions from adjacent sub-blocks or *Base Station RF Bandwidth* on each side of the *Inter RF Bandwidth gap*, where the contribution from the far-end sub-block or *Base Station RF Bandwidth* shall be scaled according to the measurement bandwidth of the near-end sub-block or *Base Station RF Bandwidth*.

Table 9.7.4.3.2-2: Spectrum emission mask values,  $45 \text{ dBm} \leq P_{\text{rated,c,TRP}} < 49 \text{ dBm}$  for UTRA FDD bands

Frequency offset of measurement filter -3 dB point, $\Delta f$	Frequency offset of measurement filter centre frequency, $f_{\text{offset}}$	minimum requirement (NOTE 1, 2)	Measurement bandwidth (NOTE 4)
$2.5 \text{ MHz} \leq \Delta f < 2.7 \text{ MHz}$	$2.515 \text{ MHz} \leq f_{\text{offset}} < 2.715 \text{ MHz}$	-8 dBm	30 kHz
$2.7 \text{ MHz} \leq \Delta f < 3.5 \text{ MHz}$	$2.715 \text{ MHz} \leq f_{\text{offset}} < 3.515 \text{ MHz}$	$-8 \text{ dBm} - 15 \cdot \left( \frac{f_{\text{offset}}}{\text{MHz}} - 2.715 \right) \text{ dB}$	30 kHz
(NOTE 3)	$3.515 \text{ MHz} \leq f_{\text{offset}} < 4.0 \text{ MHz}$	-20 dBm	30 kHz
$3.5 \text{ MHz} \leq \Delta f < 7.5 \text{ MHz}$	$4.0 \text{ MHz} \leq f_{\text{offset}} < 8.0 \text{ MHz}$	-7 dBm	1 MHz
$7.5 \text{ MHz} \leq \Delta f \leq \Delta f_{\text{max}}$	$8.0 \text{ MHz} \leq f_{\text{offset}} < f_{\text{offset}_{\text{max}}}$	$P_{\text{rated,c,TRP}} - 56 \text{ dB}$	1 MHz

NOTE 1: For a RIB supporting *non-contiguous spectrum* operation the *minimum requirement* within *sub-block gaps* within any operating band is calculated as a cumulative sum of contributions from adjacent sub blocks on each side of the *sub-block gap*, where the contribution from the far-end sub-block shall be scaled according to the measurement bandwidth of the near-end sub-block. Exception is  $\Delta f \geq 12.5 \text{ MHz}$  from both adjacent sub blocks on each side of the *sub-block gap*, where the spurious emission *minimum requirement* in subclause 9.7.6 shall be met.

NOTE 2: For a *multi-band RIB* with *Inter RF Bandwidth gap*  $< 2 \times \Delta f_{\text{OBUE}}$  the *minimum requirement* within the *Inter RF Bandwidth gaps* is calculated as a cumulative sum of contributions from adjacent sub-blocks or *Base Station RF Bandwidth* on each side of the *Inter RF Bandwidth gap*, where the contribution from the far-end sub-block or *Base Station RF Bandwidth* shall be scaled according to the measurement bandwidth of the near-end sub-block or *Base Station RF Bandwidth*.

**Table 9.7.4.3.2-3: Spectrum emission mask values,  $37 \text{ dBm} \leq P_{\text{rated,c,TRP}} < 45 \text{ dBm}$  for UTRA FDD bands**

Frequency offset of measurement filter - 3 dB point, $\Delta f$	Frequency offset of measurement filter centre frequency, $f_{\text{offset}}$	Minimum requirement (NOTE 1, 2)	Measurement bandwidth (NOTE 4)
$2.5 \text{ MHz} \leq \Delta f < 2.7 \text{ MHz}$	$2.515 \text{ MHz} \leq f_{\text{offset}} < 2.715 \text{ MHz}$	$P_{\text{rated,c,TRP}} - 53 \text{ dB}$	30 kHz
$2.7 \text{ MHz} \leq \Delta f < 3.5 \text{ MHz}$	$2.715 \text{ MHz} \leq f_{\text{offset}} < 3.515 \text{ MHz}$	$P_{\text{rated,c,TRP}} - 53 \text{ dB} - 15 \cdot (f_{\text{offset}} / \text{MHz} - 2.715) \text{ dB}$	30 kHz
(NOTE 3)	$3.515 \text{ MHz} \leq f_{\text{offset}} < 4.0 \text{ MHz}$	$P_{\text{rated,c,TRP}} - 65 \text{ dB}$	30 kHz
$3.5 \text{ MHz} \leq \Delta f < 7.5 \text{ MHz}$	$4.0 \text{ MHz} \leq f_{\text{offset}} < 8.0 \text{ MHz}$	$P_{\text{rated,c,TRP}} - 52 \text{ dB}$	1 MHz
$7.5 \text{ MHz} \leq \Delta f \leq \Delta f_{\text{max}}$	$8.0 \text{ MHz} \leq f_{\text{offset}} < f_{\text{offset}_{\text{max}}}$	$P_{\text{rated,c,TRP}} - 56 \text{ dB}$	1 MHz

NOTE 1: For a RIB supporting *non-contiguous spectrum* operation the *minimum requirement* within *sub-block gaps* within any operating band is calculated as a cumulative sum of contributions from adjacent sub blocks on each side of the *sub-block gap*, where the contribution from the far-end sub-block shall be scaled according to the measurement bandwidth of the near-end sub-block. Exception is  $\Delta f \geq 12.5 \text{ MHz}$  from both adjacent sub blocks on each side of the *sub-block gap*, where the spurious emission *minimum requirements* in subclause 9.7.6 shall be met.

NOTE 2: For a *multi-band RIB* with *Inter RF Bandwidth gap*  $< 2 \times \Delta f_{\text{OBUE}}$  the *minimum requirement* within the *Inter RF Bandwidth gaps* is calculated as a cumulative sum of contributions from adjacent sub-blocks or *Base Station RF Bandwidth* on each side of the *Inter RF Bandwidth gap*, where the contribution from the far-end sub-block or *Base Station RF Bandwidth* shall be scaled according to the measurement bandwidth of the near-end sub-block or *Base Station RF Bandwidth*.

**Table 9.7.4.3.2-4: Spectrum emission mask values,  $P_{\text{rated,c,TRP}} < 37 \text{ dBm}$  for UTRA FDD bands**

Frequency offset of measurement filter - 3 dB point, $\Delta f$	Frequency offset of measurement filter centre frequency, $f_{\text{offset}}$	Minimum requirement (NOTE 1, 2)	Measurement bandwidth (NOTE 4)
$2.5 \text{ MHz} \leq \Delta f < 2.7 \text{ MHz}$	$2.515 \text{ MHz} \leq f_{\text{offset}} < 2.715 \text{ MHz}$	-16 dBm	30 kHz
$2.7 \leq \Delta f < 3.5 \text{ MHz}$	$2.715 \text{ MHz} \leq f_{\text{offset}} < 3.515 \text{ MHz}$	$-16 \text{ dBm} - 15 \cdot \left( \frac{f_{\text{offset}}}{\text{MHz}} - 2.715 \right) \text{ dB}$	30 kHz
(NOTE 3)	$3.515 \text{ MHz} \leq f_{\text{offset}} < 4.0 \text{ MHz}$	-28 dBm	30 kHz
$3.5 \text{ MHz} \leq \Delta f < 7.5 \text{ MHz}$	$4.0 \text{ MHz} \leq f_{\text{offset}} < 8.0 \text{ MHz}$	-15 dBm	1 MHz
$7.5 \text{ MHz} \leq \Delta f \leq \Delta f_{\text{max}}$	$8.0 \text{ MHz} \leq f_{\text{offset}} < f_{\text{offset}_{\text{max}}}$	-19 dBm	1 MHz

NOTE 1: For a RIB supporting *non-contiguous spectrum* operation the *minimum requirement* within *sub-block gaps* within any operating band is calculated as a cumulative sum of contributions from adjacent sub blocks on each side of the *sub-block gap*, where the contribution from the far-end sub-block shall be scaled according to the measurement bandwidth of the near-end sub-block. Exception is  $\Delta f \geq 12.5 \text{ MHz}$  from both adjacent sub blocks on each side of the *sub-block gap*, where the spurious emission *minimum requirements* in subclause 9.7.6 shall be met.

NOTE 2: For a *multi-band RIB* with *Inter RF Bandwidth gap*  $< 2 \times \Delta f_{\text{OBUE}}$  the *minimum requirement* within the *Inter RF Bandwidth gaps* is calculated as a cumulative sum of contributions from adjacent sub-blocks or *Base Station RF Bandwidth* on each side of the *Inter RF Bandwidth gap*, where the contribution from the far-end sub-block or *Base Station RF Bandwidth* shall be scaled according to the measurement bandwidth of the near-end sub-block or *Base Station RF Bandwidth*.

For operation in band II, IV, V, X, XII, XIII, XIV, XXV and XXVI, the additional requirement in tables 9.7.4.3.2-5 to 9.7.4.3.2-7 apply in addition to the *minimum requirements* in tables 9.7.4.3.2-1 to 9.7.4.3.2-4.

**Table 9.7.4.3.2-5: Additional spectrum emission minimum requirements for Bands II, IV, X, XXV**

Frequency offset of measurement filter -3dB point, $\Delta f$	Frequency offset of measurement filter centre frequency, $f_{\text{offset}}$	Additional minimum requirement	Measurement bandwidth (NOTE 4)
$2.5 \text{ MHz} \leq \Delta f < 3.5 \text{ MHz}$	$2.515 \text{ MHz} \leq f_{\text{offset}} < 3.515 \text{ MHz}$	-9 dBm	30 kHz
$3.5 \text{ MHz} \leq \Delta f \leq \Delta f_{\text{max}}$	$4.0 \text{ MHz} \leq f_{\text{offset}} < f_{\text{offset}_{\text{max}}}$	-7 dBm	1 MHz

**Table 9.7.4.3.2-6: Additional spectrum emission minimum requirements for Bands V, XXVI**

Frequency offset of measurement filter -3dB point, $\Delta f$	Frequency offset of measurement filter centre frequency, $f_{\text{offset}}$	Additional minimum requirement	Measurement bandwidth (NOTE 4)
$2.5 \text{ MHz} \leq \Delta f < 3.5 \text{ MHz}$	$2.515 \text{ MHz} \leq f_{\text{offset}} < 3.515 \text{ MHz}$	-9 dBm	30 kHz
$3.5 \text{ MHz} \leq \Delta f \leq \Delta f_{\text{max}}$	$3.55 \text{ MHz} \leq f_{\text{offset}} < f_{\text{offset}_{\text{max}}}$	-7 dBm	100 kHz

**Table 9.7.4.3.2-7: Additional spectrum emission minimum requirements for Bands XII, XIII, XIV**

Frequency offset of measurement filter -3dB point, $\Delta f$	Frequency offset of measurement filter centre frequency, $f_{\text{offset}}$	Additional minimum requirement	Measurement bandwidth (NOTE 4)
$2.5 \text{ MHz} \leq \Delta f < 2.6 \text{ MHz}$	$2.515 \text{ MHz} \leq f_{\text{offset}} < 2.615 \text{ MHz}$	-7 dBm	30 kHz
$2.6 \text{ MHz} \leq \Delta f \leq \Delta f_{\text{max}}$	$2.65 \text{ MHz} \leq f_{\text{offset}} < f_{\text{offset}_{\text{max}}}$	-7 dBm	100 kHz

In certain regions the following requirement may apply for protection of DTT. For a RIB operating in Band XX, the level of emissions in the band 470-790 MHz, measured in an 8MHz filter bandwidth on centre frequencies  $F_{\text{filter}}$  according to table 9.7.4.3.2-8, shall not exceed the emission TRP limits as specified in table 9.7.4.3.2-8

Table 9.7.4.3.2-8: Emissions levels for protection of DTT

Case	Measurement filter centre frequency	Condition on BS maximum aggregate EIRP / 10 MHz, $P_{\text{EIRP}_10\text{MHz}}$ (NOTE)	Maximum Level $P_{\text{EIRP},N,\text{MAX}}$	Measurement Bandwidth
A: for DTT frequencies where broadcasting is protected	$N*8 + 306 \text{ MHz}$ , $21 \leq N \leq 60$	$P_{\text{EIRP}_10\text{MHz}} \geq 59 \text{ dBm}$	0 dBm	8 MHz
	$N*8 + 306 \text{ MHz}$ , $21 \leq N \leq 60$	$36 \leq P_{\text{EIRP}_10\text{MHz}} < 59 \text{ dBm}$	$P_{\text{EIRP}_10\text{MHz}} - 59 \text{ dBm}$	8 MHz
	$N*8 + 306 \text{ MHz}$ , $21 \leq N \leq 60$	$P_{\text{EIRP}_10\text{MHz}} < 36 \text{ dBm}$	-23 dBm	8 MHz
B: for DTT frequencies where broadcasting is subject to an intermediate level of protection	$N*8 + 306 \text{ MHz}$ , $21 \leq N \leq 60$	$P_{\text{EIRP}_10\text{MHz}} \geq 59 \text{ dBm}$	10 dBm	8 MHz
	$N*8 + 306 \text{ MHz}$ , $21 \leq N \leq 60$	$36 \leq P_{\text{EIRP}_10\text{MHz}} < 59 \text{ dBm}$	$P_{\text{EIRP}_10\text{MHz}} - 49 \text{ dBm}$	8 MHz
	$N*8 + 306 \text{ MHz}$ , $21 \leq N \leq 60$	$P_{\text{EIRP}_10\text{MHz}} < 36 \text{ dBm}$	-13 dBm	8 MHz
C: for DTT frequencies where broadcasting is not protected	$N*8 + 306 \text{ MHz}$ , $21 \leq N \leq 60$	N.A.	22 dBm	8 MHz
NOTE: $P_{\text{EIRP}_10\text{MHz}}$ (dBm) is defined by the expression $P_{\text{EIRP}_10\text{MHz}} = P_{10\text{MHz}} + G_{\text{ant}} + 6 \text{ dB}$ for UTRA and $P_{\text{EIRP}_10\text{MHz}} = P_{10\text{MHz}} + G_{\text{ant}} + 9 \text{ dB}$ for E-UTRA, where $G_{\text{ant}}$ is 17 dBi.				

NOTE: The regional requirement is defined in terms of EIRP (effective isotropic radiated power), which is dependent on both the BS emissions at the antenna connector and the deployment (including antenna gain and feeder loss). The method outlined in annex B1 Indicates how the limit in table 9.7.4.3.2-8 demonstrates compliance to the regional requirement.

In certain regions, the following *basic limits* may apply to a RIB operating in Band XXXII within 1452-1492 MHz. The level of unwanted emissions, measured on centre frequencies  $f_{\text{offset}}$  with filter bandwidth, according to table 9.7.4.3.2-9, shall not exceed the maximum TRP limits indicated in the table.

Table 9.7.4.3.2-9: Declared frequency band XXXII unwanted emission within 1452-1492 MHz

Frequency offset of measurement filter centre frequency, $f_{\text{offset}}$	Maximum Level [dBm]	Measurement bandwidth
5 MHz	$P_{\text{EIRP}} - 17 \text{ dBi} + 6 \text{ dB}$	5 MHz
10 MHz	$P_{\text{EIRP}} - 17 \text{ dBi} + 6 \text{ dB}$	5 MHz
$15 \text{ MHz} \leq f_{\text{offset}} \leq f_{\text{offset}_{\text{max}, \text{B32}}}$	$P_{\text{EIRP}} - 17 \text{ dBi} + 6 \text{ dB}$	5 MHz
NOTE: $f_{\text{offset}_{\text{max}, \text{B32}}}$ denotes the frequency difference between the lower channel carrier frequency and 1454.5 MHz, and the frequency difference between the upper channel carrier frequency and 1489.5 MHz for the set channel position.		

NOTE: The regional requirement, included in CEPT ECC Decision (13)03 [25], is defined in terms of EIRP per antenna, which is dependent on both the BS emissions at the antenna connector and the deployment (including antenna gain and feeder loss). The method outlined in annex B1 Indicates how the limit in table 9.7.4.3.2-9 demonstrates compliance to the regional requirement.

In certain regions, the following *basic limit* may apply to RIB operating in Band XXXII within 1452-1492 MHz for the protection of services in spectrum adjacent to the frequency range 1452-1492 MHz. The level of emissions, measured on centre frequencies  $F_{\text{filter}}$  with filter bandwidth according to table 9.7.4.3.2-10, shall not exceed the maximum emission TRP limits in the table. This requirement applies in the frequency range 1429-1518 MHz even though part of the range falls in the spurious domain.

**Table 9.7.4.3.2-10: Frequency band XXXII declared emission outside 1452-1492 MHz**

Filter centre frequency, $F_{\text{filter}}$	Maximum level [dBm]	Measurement bandwidth
$1429.5 \text{ MHz} \leq F_{\text{filter}} \leq 1448.5 \text{ MHz}$	$P_{\text{EIRP}} - 17 \text{ dBi} + 6 \text{ dB}$	1 MHz
$F_{\text{filter}} = 1450.5 \text{ MHz}$	$P_{\text{EIRP}} - 17 \text{ dBi} + 6 \text{ dB}$	3 MHz
$F_{\text{filter}} = 1493.5 \text{ MHz}$	$P_{\text{EIRP}} - 17 \text{ dBi} + 6 \text{ dB}$	3 MHz
$1495.5 \text{ MHz} \leq F_{\text{filter}} \leq 1517.5 \text{ MHz}$	$P_{\text{EIRP}} - 17 \text{ dBi} + 6 \text{ dB}$	1 MHz

NOTE: The regional requirement, included in CEPT ECC Decision (13)03 [25], is defined in terms of EIRP, which is dependent on both the BS emissions at the antenna connector and the deployment (including antenna gain and feeder loss). The method outlined in annex B1 Indicates how the limit in table 9.7.4.3.2-10 demonstrates compliance to the regional requirement.

Notes for the tables in this subclause:

NOTE 3: This frequency range ensures that the range of values of  $f_{\text{offset}}$  is continuous.

NOTE 4: As a general rule, the resolution bandwidth of the measuring equipment should be equal to the measurement bandwidth. However, to improve measurement accuracy, sensitivity and efficiency, the resolution bandwidth can be smaller than the measurement bandwidth. When the resolution bandwidth is smaller than the measurement bandwidth, the result should be integrated over the measurement bandwidth in order to obtain the equivalent noise bandwidth of the measurement bandwidth.

#### 9.7.4.4 Minimum requirement for single RAT E-UTRA operation

There is no spectrum emission mask requirement for a single RAT E-UTRA AAS BS.

### 9.7.5 OTA Operating band unwanted emission

#### 9.7.5.1 General

Unless otherwise stated, for E-UTRA single band and MSR the operating band unwanted emission limits are defined from  $\Delta f_{\text{OBUE}}$  below the lowest frequency of each supported *downlink operating band* to the lower *Base Station RF Bandwidth edge* located at  $F_{\text{BW RF,low}}$  and from the upper *Base Station RF Bandwidth edge* located at  $F_{\text{BW RF,high}}$  up to  $\Delta f_{\text{OBUE}}$  above the highest frequency of each supported *downlink operating band*. The values of  $\Delta f_{\text{OBUE}}$  are defined in table 9.7.1-1.

The requirements shall apply whatever the type of transmitter considered and for all transmission modes foreseen by the manufacturer's specification.

The operating band unwanted emissions minimum requirements are quoted as TRP per *RIB* unless otherwise stated.

The requirements shall apply whatever the type of *RIB* is considered (single carrier or multi-carrier) and for all transmission modes foreseen by the manufacturer's specification. In addition, for a *RIB* operating in *non-contiguous spectrum*, the requirements apply inside any *sub-block gap*. In addition, for a *multi-band RIB* the requirements apply inside any *Inter RF Bandwidth gap*.

The unwanted emission limits in the part of the *downlink operating band* that falls in the spurious domain are consistent with ITU-R Recommendation SM.329 [14].

Additional limits in clause 9.7.5.2.4.7 may apply outside *OBUE* frequency domain.

Emissions shall use the minimum requirements specified in the tables below, where:

- $\Delta f$  is the separation between the channel edge frequency and the nominal -3dB point of the measuring filter closest to the carrier frequency.
- $f_{\text{offset}}$  is the separation between the channel edge frequency and the centre of the measuring filter.
- $f_{\text{offset}_{\text{max}}}$  is the offset to the frequency  $\Delta f_{\text{OBUE}}$  MHz outside the *downlink operating band*.

- $\Delta f_{\max}$  is equal to  $f_{\text{offset}_{\max}}$  minus half of the bandwidth of the measuring filter.

For a *multi-band RIB* inside any *Inter RF Bandwidth gaps* with  $W_{\text{gap}} < 2 \times \Delta f_{\text{OBUE}}$ , emissions shall not exceed the cumulative sum of the minimum requirements specified at the *Base Station RF Bandwidth edges* on each side of the *Inter RF Bandwidth gap*. The minimum requirement for *Base Station RF Bandwidth edge* is specified in the subclause 9.7.5.4.2 to 9.7.5.4.7 below, where in this case:

- $\Delta f$  is the separation between the *Base Station RF Bandwidth edge* frequency and the nominal -3 dB point of the measuring filter closest to the *Base Station RF Bandwidth edge*.
- $f_{\text{offset}}$  is the separation between the *Base Station RF Bandwidth edge* frequency and the centre of the measuring filter.
- $f_{\text{offset}_{\max}}$  is equal to the *Inter RF Bandwidth gap* minus half of the bandwidth of the measuring filter.
- $\Delta f_{\max}$  is equal to  $f_{\text{offset}_{\max}}$  minus half of the bandwidth of the measuring filter.

For *multi-band RIB*, the operating band unwanted emission limits apply also in a supported operating band without any carrier transmitted, in the case where there are carrier(s) transmitted in another supported operating band. In this case, no cumulative limit is applied in the *inter-band gap* between a supported *downlink operating band* with carrier(s) transmitted and a supported *downlink operating band* without any carrier transmitted and

- In case the *inter-band gap* between a supported *downlink operating band* with carrier(s) transmitted and a supported *downlink operating band* without any carrier transmitted is less than  $2 \times \Delta f_{\text{OBUE}}$ ,  $f_{\text{offset}_{\max}}$  shall be the offset to the frequency  $\Delta f_{\text{OBUE}}$  MHz outside the outermost edges of the two supported *downlink operating bands* and the operating band unwanted emission limit of the band where there are carriers transmitted, as defined in the tables of the present subclause, shall apply across both downlink bands.
- In other cases, the operating band unwanted emission limit of the band where there are carriers transmitted, as defined in the tables of the present subclause for the largest frequency offset ( $\Delta f_{\max}$ ), shall apply from  $\Delta f_{\text{OBUE}}$  MHz below the lowest frequency, up to  $\Delta f_{\text{OBUE}}$  MHz above the highest frequency of the supported *downlink operating band* without any carrier transmitted.

For a multicarrier E-UTRA RIB or a RIB configured for intra-band contiguous or non-contiguous *carrier aggregation* the definitions above apply to the lower edge of the carrier transmitted at the lowest carrier frequency and the upper edge of the carrier transmitted at the highest carrier frequency within a specified frequency band.

In addition, inside any *sub-block gap* for a RIB operating in *non-contiguous spectrum*, emissions shall not exceed the cumulative sum of the minimum requirements specified for the adjacent sub blocks on each side of the *sub-block gap*. The minimum requirement for each sub block is specified in the tables sub-clause 9.7.5.4.2 to 9.7.5.4.7 below, where in this case:

- $\Delta f$  is the separation between the sub block edge frequency and the nominal -3 dB point of the measuring filter closest to the sub block edge.
- $f_{\text{offset}}$  is the separation between the sub block edge frequency and the centre of the measuring filter.
- $f_{\text{offset}_{\max}}$  is equal to the *sub-block gap* bandwidth minus half of the bandwidth of the measuring filter.
- $\Delta f_{\max}$  is equal to  $f_{\text{offset}_{\max}}$  minus half of the bandwidth of the measuring filter.
- $\Delta f_{\text{OBUE}}$  is defined in clause 6.6.1.

## 9.7.5.2 Minimum requirement for MSR operation

### 9.7.5.2.1 General

The MSR operating band unwanted emission minimum requirements are given in subclauses 9.7.5.2.2, 9.7.5.2.3, and 9.7.5.2.4.

### 9.7.5.2.2 Minimum requirements for Band Categories 1 and 3

For an MSR RIB operating in BC1 or BC3 bands, the minimum requirements are specified in tables 9.7.5.2.2-1 to 9.7.5.2.2-4, dependent on BS class and output power.

Applicability of Wide Area operating band unwanted emission requirements in tables 9.7.5.2.2-1, 9.7.5.2.2-1a and 9.7.5.2.2-1b is specified in table 9.7.5.2.2-0.

**Table 9.7.5.2.2-0: Applicability of operating band unwanted emission requirements for BC1 and BC3 Wide Area BS**

NR band operation	UTRA supported	Applicable requirement table
None	Y/N	9.7.5.2.2-1 (option 2)
In certain regions (NOTE 2), bands 3, 8	N	9.7.5.2.2-1 (option 2)
Any below 1 GHz except for certain regions (NOTE 2), band 8	N	9.7.5.2.2-1a (option 1)
Any above 1 GHz except for certain regions (NOTE 2), band 3	N	9.7.5.2.2-1b (option 1)
NOTE 1: Void.		
NOTE 2: Applicable only for operation in regions where Category B limits as defined in ITU-R Recommendation SM.329 [14] are used for which category B option 2 operating band unwanted emissions requirements as defined in TS 36.104 [8] and TS 38.104 [27] are applied.		

**Table 9.7.5.2.2-1: WA BS OBUE in BC1 and BC3 bands applicable for: BS not supporting NR; or BS supporting NR in Band n1 or n65**

Frequency offset of measurement filter -3dB point, $\Delta f$	Frequency offset of measurement filter centre frequency, $f_{\text{offset}}$	Minimum requirement (NOTE 1, 2)	Measurement bandwidth (NOTE 4)
$0 \text{ MHz} \leq \Delta f < 0.2 \text{ MHz}$	$0.015 \text{ MHz} \leq f_{\text{offset}} < 0.215 \text{ MHz}$	-5 dBm	30 kHz
$0.2 \text{ MHz} \leq \Delta f < 1 \text{ MHz}$	$0.215 \text{ MHz} \leq f_{\text{offset}} < 1.015 \text{ MHz}$	$-5 \text{ dBm} - 15 \cdot \left( \frac{f_{\text{offset}}}{\text{MHz}} - 0.215 \right) \text{ dB}$	30 kHz
(NOTE 3)	$1.015 \text{ MHz} \leq f_{\text{offset}} < 1.5 \text{ MHz}$	-17 dBm	30 kHz
$1 \text{ MHz} \leq \Delta f \leq \min(\Delta f_{\text{max}}, 10 \text{ MHz})$	$1.5 \text{ MHz} \leq f_{\text{offset}} < \min(f_{\text{offset}_{\text{max}}}, 10.5 \text{ MHz})$	-4 dBm	1 MHz
$10 \text{ MHz} \leq \Delta f \leq \Delta f_{\text{max}}$	$10.5 \text{ MHz} \leq f_{\text{offset}} < f_{\text{offset}_{\text{max}}}$	-6 dBm (NOTE 5)	1 MHz
NOTE 1: For MSR RIB supporting <i>non-contiguous spectrum</i> operation within any operating band the <i>minimum requirement</i> within <i>sub-block gaps</i> is calculated as a cumulative sum of contributions from adjacent sub-blocks on each side of the <i>sub-block gap</i> , where the contribution from the far-end sub-block shall be scaled according to the measurement bandwidth of the near-end sub-block. Exception is $\Delta f \geq 10 \text{ MHz}$ from both adjacent sub-blocks on each side of the <i>sub-block gap</i> , where the <i>minimum requirement</i> within <i>sub-block gaps</i> shall be -6dBm/MHz.			
NOTE2: For MSR <i>multi-band RIB</i> with <i>Inter RF Bandwidth gap</i> $< 2 \times \Delta f_{\text{OBUE}}$ the <i>minimum requirement</i> within the <i>Inter RF Bandwidth gaps</i> is calculated as a cumulative sum of contributions from adjacent sub-blocks or <i>Base Station RF Bandwidth</i> on each side of the <i>Inter RF Bandwidth gap</i> , where the contribution from the far-end sub-block or RF Bandwidth shall be scaled according to the measurement bandwidth of the near-end sub-block or RF Bandwidth.			

**Table 9.7.5.2.2-1a: WA BS OBUE in BC1 and BC3 bands ≤ 1 GHz applicable for: BS supporting NR and not supporting UTRA**

Frequency offset of measurement filter -3dB point, $\Delta f$	Frequency offset of measurement filter centre frequency, $f_{\text{offset}}$	Minimum requirement (Note 1, 2)	Measurement bandwidth (Note 4)
$0 \text{ MHz} \leq \Delta f < 5 \text{ MHz}$	$0.05 \text{ MHz} \leq f_{\text{offset}} < 5.05 \text{ MHz}$	$2\text{dBm} - \frac{7}{5} \cdot \left( \frac{f_{\text{offset}}}{\text{MHz}} - 0.05 \right) \text{dB}$	100 kHz
$5 \text{ MHz} \leq \Delta f < \min(10 \text{ MHz}, \Delta f_{\text{max}})$	$5.05 \text{ MHz} \leq f_{\text{offset}} < \min(10.05 \text{ MHz}, f_{\text{offset}_{\text{max}}})$	-5 dBm	100 kHz
$10 \text{ MHz} \leq \Delta f \leq \Delta f_{\text{max}}$	$10.05 \text{ MHz} \leq f_{\text{offset}} < f_{\text{offset}_{\text{max}}}$	-7 dBm (Note 5)	100 kHz
<p>NOTE 1: For MSR <i>RIB</i> supporting non-contiguous spectrum operation within any operating band, the <i>minimum requirement</i> within <i>sub-block gaps</i> is calculated as a cumulative sum of contributions from adjacent sub blocks on each side of the <i>sub block gap</i>. Exception is <math>\Delta f \geq 10\text{MHz}</math> from both adjacent sub blocks on each side of the <i>sub-block gap</i>, where the <i>minimum requirement</i> within sub-block gaps shall be -7dBm/100kHz.</p> <p>NOTE 2: For MSR <i>multi band RIB</i> with <i>Inter RF Bandwidth gap</i> <math>&lt; 2 \times \Delta f_{\text{OBUE}}</math> the <i>minimum requirement</i> within the <i>Inter RF Bandwidth gaps</i> is calculated as a cumulative sum of contributions from adjacent sub-blocks or Base station <i>RF Bandwidth</i> on each side of the <i>Inter RF Bandwidth gap</i>.</p> <p>NOTE 3: For operation with an E-UTRA 1.4 or 3MHz carrier adjacent to the Base Station RF Bandwidth edge, the limits in Table 6.6.2.2-2 apply for <math>0 \text{ MHz} \leq \Delta f &lt; 0.15 \text{ MHz}</math>.</p>			

**Table 9.7.5.2.2-1b: WA BS OBUE in BC1 and BC3 bands > 1 GHz applicable for: BS supporting NR, not operating in band n1 or n65, and not supporting UTRA**

Frequency offset of measurement filter -3dB point, $\Delta f$	Frequency offset of measurement filter centre frequency, $f_{\text{offset}}$	Minimum requirement (Note 1, 2)	Measurement bandwidth (Note 4)
$0 \text{ MHz} \leq \Delta f < 5 \text{ MHz}$	$0.05 \text{ MHz} \leq f_{\text{offset}} < 5.05 \text{ MHz}$	$2\text{dBm} - \frac{7}{5} \cdot \left( \frac{f_{\text{offset}}}{\text{MHz}} - 0.05 \right) \text{dB}$	100 kHz
$5 \text{ MHz} \leq \Delta f < \min(10 \text{ MHz}, \Delta f_{\text{max}})$	$5.05 \text{ MHz} \leq f_{\text{offset}} < \min(10.05 \text{ MHz}, f_{\text{offset}_{\text{max}}})$	-5 dBm	100 kHz
$10 \text{ MHz} \leq \Delta f \leq \Delta f_{\text{max}}$	$10.5 \text{ MHz} \leq f_{\text{offset}} < f_{\text{offset}_{\text{max}}}$	-6 dBm (Note 5)	1MHz
<p>NOTE 1: For MSR <i>RIB</i> supporting non-contiguous spectrum operation within any operating band, the <i>minimum requirement</i> within sub-block gaps is calculated as a cumulative sum of contributions from adjacent sub blocks on each side of the <i>sub block gap</i>, where the contribution from the far-end sub-block shall be scaled according to the measurement bandwidth of the near-end sub-block. Exception is <math>\Delta f \geq 10\text{MHz}</math> from both adjacent sub blocks on each side of the <i>sub-block gap</i>, where the <i>minimum requirement</i> within sub-block gaps shall be -6dBm/1MHz.</p> <p>NOTE 2: For MSR <i>multi band RIB</i> with <i>Inter RF Bandwidth gap</i> <math>&lt; 2 \times \Delta f_{\text{OBUE}}</math> the <i>basic limit</i> within the <i>Inter RF Bandwidth gaps</i> is calculated as a cumulative sum of contributions from adjacent sub-blocks or <i>RF Bandwidth</i> on each side of the <i>Inter RF Bandwidth gap</i>, where the contribution from the far-end sub-block or <i>RF Bandwidth</i> shall be scaled according to the measurement bandwidth of the near-end sub-block or <i>RF Bandwidth</i>.</p> <p>NOTE 3: For operation with an E-UTRA 1.4 or 3MHz carrier adjacent to the Base Station RF Bandwidth edge, the limits in Table 6.6.2.2-2 apply for <math>0 \text{ MHz} \leq \Delta f &lt; 0.15 \text{ MHz}</math>.</p>			

**Table 9.7.5.2.2-2: MR BS OBUE in BC1 bands applicable for: BS with maximum output power 40 <  $P_{\text{rated,c,TRP}} \leq 47$  dBm and not supporting NR**

Frequency offset of measurement filter -3dB point, $\Delta f$	Frequency offset of measurement filter centre frequency, $f_{\text{offset}}$	Minimum requirement (NOTE 1, 2)	Measurement bandwidth (NOTE 4)
$0 \text{ MHz} \leq \Delta f < 0.6 \text{ MHz}$	$0.015 \text{ MHz} \leq f_{\text{offset}} < 0.615 \text{ MHz}$	$P_{\text{rated,c,TRP}} - 58 \text{ dB} - (5/3) \cdot (f_{\text{offset}} - 0.015) \text{ dB}$	30 kHz
$0.6 \text{ MHz} \leq \Delta f < 1 \text{ MHz}$	$0.615 \text{ MHz} \leq f_{\text{offset}} < 1.015 \text{ MHz}$	$P_{\text{rated,c,TRP}} - 53 \text{ dB} - 15 \cdot (f_{\text{offset}} - 0.015) \text{ dB}$	30 kHz
(NOTE 3)	$1.015 \text{ MHz} \leq f_{\text{offset}} < 1.5 \text{ MHz}$	$P_{\text{rated,c,TRP}} - 65 \text{ dB}$	30 kHz
$1 \text{ MHz} \leq \Delta f \leq 2.6 \text{ MHz}$	$1.5 \text{ MHz} \leq f_{\text{offset}} < 3.1 \text{ MHz}$	$P_{\text{rated,c,TRP}} - 52 \text{ dB}$	1 MHz
$2.6 \text{ MHz} \leq \Delta f \leq 5 \text{ MHz}$	$3.1 \text{ MHz} \leq f_{\text{offset}} < 5.5 \text{ MHz}$	$\min(P_{\text{rated,c,TRP}} - 52 \text{ dB}, -6 \text{ dBm})$	1 MHz
$5 \text{ MHz} \leq \Delta f \leq \Delta f_{\text{max}}$	$5.5 \text{ MHz} \leq f_{\text{offset}} < f_{\text{offset}_{\text{max}}}$	$P_{\text{rated,c,TRP}} - 56 \text{ dB}$	1 MHz
<p>NOTE 1: For MSR RIB supporting <i>non-contiguous spectrum</i> operation within any operating band the <i>minimum requirement</i> within <i>sub-block gaps</i> is calculated as a cumulative sum of contributions from adjacent sub blocks on each side of the <i>sub-block gap</i>, where the contribution from the far-end sub-block shall be scaled according to the measurement bandwidth of the near-end sub-block. Exception is <math>\Delta f \geq 10 \text{ MHz}</math> from both adjacent sub-blocks on each side of the <i>sub-block gap</i>, where the <i>minimum requirement</i> within <i>sub-block gaps</i> shall be <math>(P_{\text{rated,c,TRP}} - 56 \text{ dB}) / \text{MHz}</math>.</p> <p>NOTE 2: For MSR multi-band RIB with <i>Inter RF Bandwidth gap</i> <math>&lt; 2 \times \Delta f_{\text{OBUE}}</math> the <i>minimum requirement</i> within the <i>Inter RF Bandwidth gaps</i> is calculated as a cumulative sum of contributions from adjacent sub-blocks or <i>Base Station RF Bandwidth</i> on each side of the <i>Inter RF Bandwidth gap</i>, where the contribution from the far-end sub-block or <i>Base Station RF Bandwidth</i> shall be scaled according to the measurement bandwidth of the near-end sub-block or <i>Base Station RF Bandwidth</i>.</p>			

**Table 9.7.5.2.2-2a: MR BS OBUE in BC1 bands applicable for: BS with maximum output power 40 <  $P_{\text{rated,c,TRP}} \leq 47$  dBm BS, supporting NR and not supporting UTRA**

Frequency offset of measurement filter -3dB point, $\Delta f$	Frequency offset of measurement filter centre frequency, $f_{\text{offset}}$	Minimum requirement (Note 1, 2)	Measurement bandwidth (Note 4)
$0 \text{ MHz} \leq \Delta f < 5 \text{ MHz}$	$0.05 \text{ MHz} \leq f_{\text{offset}} < 5.05 \text{ MHz}$	$P_{\text{rated,c,TRP}} - 53 \text{ dB} - (7/5) \cdot (f_{\text{offset}} - 0.05) \text{ dB}$	100 kHz
$5 \text{ MHz} \leq \Delta f < \min(10 \text{ MHz}, \Delta f_{\text{max}})$	$5.05 \text{ MHz} \leq f_{\text{offset}} < \min(10.05 \text{ MHz}, f_{\text{offset}_{\text{max}}})$	$P_{\text{rated,c,TRP}} - 60 \text{ dB}$	100 kHz
$10 \text{ MHz} \leq \Delta f \leq \Delta f_{\text{max}}$	$10.05 \text{ MHz} \leq f_{\text{offset}} < f_{\text{offset}_{\text{max}}}$	$\min(P_{\text{rated,c,TRP}} - 60 \text{ dB}, -16 \text{ dBm})$ (Note 4)	100 kHz
<p>NOTE 1: For MSR RIB supporting <i>non-contiguous spectrum</i> operation within any operating band the <i>minimum requirement</i> within <i>sub-block gaps</i> is calculated as a cumulative sum of contributions from adjacent sub blocks on each side of the <i>sub block gap</i>. Exception is <math>\Delta f \geq 10 \text{ MHz}</math> from both adjacent sub blocks on each side of the <i>sub-block gap</i>, where the <i>minimum requirement</i> within <i>sub-block gaps</i> shall be <math>\min(P_{\text{rated,c,TRP}} - 60 \text{ dB}, -16 \text{ dBm}) / 100 \text{ kHz}</math>.</p> <p>NOTE 2: For MSR <i>multi band RIB</i> with <i>Inter RF Bandwidth gap</i> <math>&lt; 2 \times \Delta f_{\text{OBUE}}</math> the <i>minimum requirement</i> within the <i>Inter RF Bandwidth gaps</i> is calculated as a cumulative sum of contributions from adjacent sub-blocks or RF Bandwidth on each side of the <i>Inter RF Bandwidth gap</i>.</p>			

**Table 9.7.5.2.2-3: MR BS OBUE in BC1 bands applicable for: BS with maximum output power  $P_{\text{rated,c,TRP}} \leq 40$  dBm and not supporting NR**

Frequency offset of measurement filter -3dB point, $\Delta f$	Frequency offset of measurement filter centre frequency, $f_{\text{offset}}$	Minimum requirement (NOTE 1, 2)	Measurement bandwidth (NOTE 4)
$0 \text{ MHz} \leq \Delta f < 0.6 \text{ MHz}$	$0.015 \text{ MHz} \leq f_{\text{offset}} < 0.615 \text{ MHz}$	$-18 \text{ dBm} - \frac{5}{3} \left( \frac{f_{\text{offset}}}{\text{MHz}} - 0.015 \right) \text{ dB}$	30 kHz
$0.6 \text{ MHz} \leq \Delta f < 1 \text{ MHz}$	$0.615 \text{ MHz} \leq f_{\text{offset}} < 1.015 \text{ MHz}$	$-13 \text{ dBm} - 15 \cdot \left( \frac{f_{\text{offset}}}{\text{MHz}} - 0.215 \right) \text{ dB}$	30 kHz
(NOTE 3)	$1.015 \text{ MHz} \leq f_{\text{offset}} < 1.5 \text{ MHz}$	-25 dBm	30 kHz
$1 \text{ MHz} \leq \Delta f \leq 5 \text{ MHz}$	$1.5 \text{ MHz} \leq f_{\text{offset}} < 5.5 \text{ MHz}$	-12 dBm	1 MHz
$5 \text{ MHz} \leq \Delta f \leq \Delta f_{\text{max}}$	$5.5 \text{ MHz} \leq f_{\text{offset}} < f_{\text{offset}_{\text{max}}}$	-16 dBm	1 MHz
<p>NOTE 1: For MSR RIB supporting <i>non-contiguous spectrum</i> operation within any operating band the <i>minimum requirement</i> within <i>sub-block gaps</i> is calculated as a cumulative sum of contributions from adjacent sub blocks on each side of the <i>sub-block gap</i>, where the contribution from the far-end sub-block shall be scaled according to the measurement bandwidth of the near-end sub-block. Exception is <math>\Delta f \geq 10</math> MHz from both adjacent sub-blocks on each side of the <i>sub-block gap</i>, where the <i>minimum requirement</i> within <i>sub-block gaps</i> shall be -16 dBm/MHz.</p> <p>NOTE 2: For MSR <i>multi-band RIB</i> with <i>Inter RF Bandwidth gap</i> <math>&lt; 2 \times \Delta f_{\text{OBUE}}</math> the <i>minimum requirement</i> within the <i>Inter RF Bandwidth gaps</i> is calculated as a cumulative sum of contributions from adjacent sub-blocks or <i>Base Station RF Bandwidth</i> on each side of the <i>Inter RF Bandwidth gap</i>, where the contribution from the far-end sub-block or <i>Base Station RF Bandwidth</i> shall be scaled according to the measurement bandwidth of the near-end sub-block or <i>Base Station RF Bandwidth</i>.</p>			

**Table 9.7.5.2.2-3a: MR BS OBUE in BC1 bands applicable for: BS with maximum output power  $P_{\text{rated,c,TRP}} \leq 40$  dBm, supporting NR and not supporting UTRA**

Frequency offset of measurement filter -3dB point, $\Delta f$	Frequency offset of measurement filter centre frequency, $f_{\text{offset}}$	Minimum requirement (Note 1, 2)	Measurement bandwidth (Note 4)
$0 \text{ MHz} \leq \Delta f < 5 \text{ MHz}$	$0.05 \text{ MHz} \leq f_{\text{offset}} < 5.05 \text{ MHz}$	$-13 \text{ dBm} - 7/5(f_{\text{offset}}/\text{MHz} - 0.05) \text{ dB}$	100 kHz
$5 \text{ MHz} \leq \Delta f < \min(10 \text{ MHz}, \Delta f_{\text{max}})$	$5.05 \text{ MHz} \leq f_{\text{offset}} < \min(10.05 \text{ MHz}, f_{\text{offset}_{\text{max}}})$	-20 dBm	100 kHz
$10 \text{ MHz} \leq \Delta f \leq \Delta f_{\text{max}}$	$10.05 \text{ MHz} \leq f_{\text{offset}} < f_{\text{offset}_{\text{max}}}$	-20 dBm (Note 4)	100 kHz
<p>NOTE 1: For MSR RIB supporting <i>non-contiguous spectrum</i> operation within any operating band the <i>minimum requirement</i> within <i>sub-block gaps</i> is calculated as a cumulative sum of contributions from adjacent sub blocks on each side of the <i>sub-block gap</i>. Exception is <math>\Delta f \geq 10</math> MHz from both adjacent sub blocks on each side of the <i>sub-block gap</i>, where the <i>minimum requirement</i> within <i>sub-block gaps</i> shall be -20 dBm/100 kHz.</p> <p>NOTE 2: For MSR <i>multi band RIB</i> with <i>Inter RF Bandwidth gap</i> <math>&lt; 2 \times \Delta f_{\text{OBUE}}</math> the <i>minimum requirement</i> within the <i>Inter RF Bandwidth gaps</i> is calculated as a cumulative sum of contributions from adjacent sub-blocks or <i>RF Bandwidth</i> on each side of the <i>Inter RF Bandwidth gap</i>.</p>			

**Table 9.7.5.2.2-4: LA BS OBUE in BC1 bands**

Frequency offset of measurement filter -3dB point, $\Delta f$	Frequency offset of measurement filter centre frequency, $f_{\text{offset}}$	Minimum requirement (NOTE 1, 2)	Measurement bandwidth (NOTE 4)
$0 \text{ MHz} \leq \Delta f < 5 \text{ MHz}$	$0.05 \text{ MHz} \leq f_{\text{offset}} < 5.05 \text{ MHz}$	$-21 \text{ dBm} - \frac{7}{5} \left( \frac{f_{\text{offset}}}{\text{MHz}} - 0.05 \right) \text{ dB}$	100 kHz
$5 \text{ MHz} \leq \Delta f < \min(10 \text{ MHz}, \Delta f_{\text{max}})$	$5.05 \text{ MHz} \leq f_{\text{offset}} < \min(10.05 \text{ MHz}, f_{\text{offset}_{\text{max}}})$	-28 dBm	100 kHz
$10 \text{ MHz} \leq \Delta f \leq \Delta f_{\text{max}}$	$10.05 \text{ MHz} \leq f_{\text{offset}} < f_{\text{offset}_{\text{max}}}$	-28 dBm (NOTE 5)	100 kHz
<p>NOTE 1: For MSR RIB supporting <i>non-contiguous spectrum</i> operation within any operating band the <i>minimum requirement</i> within <i>sub-block gaps</i> is calculated as a cumulative sum of contributions from adjacent sub blocks on each side of the <i>sub-block gap</i>. Exception is <math>\Delta f \geq 10</math> MHz from both adjacent sub blocks on each side of the <i>sub-block gap</i>, where the <i>minimum requirement</i> within <i>sub-block gaps</i> shall be -28 dBm/100 kHz.</p> <p>NOTE 2: For MSR <i>multi-band RIB</i> with <i>Inter RF Bandwidth gap</i> <math>&lt; 2 \times \Delta f_{\text{OBUE}}</math> the <i>minimum requirement</i> within the <i>Inter RF Bandwidth gaps</i> is calculated as a cumulative sum of contributions from adjacent sub-blocks or <i>Base Station RF Bandwidth</i> on each side of the <i>Inter RF Bandwidth gap</i>.</p>			

NOTE 3: This frequency range ensures that the range of values of  $f_{\text{offset}}$  is continuous.

NOTE 4: As a general rule for the requirements in the present subclause, the resolution bandwidth of the measuring equipment should be equal to the measurement bandwidth. However, to improve measurement accuracy, sensitivity and efficiency, the resolution bandwidth may be smaller than the measurement bandwidth. When the resolution bandwidth is smaller than the measurement bandwidth, the result should be integrated over the measurement bandwidth in order to obtain the equivalent noise bandwidth of the measurement bandwidth.

NOTE 5: The requirement is not applicable when  $\Delta f_{\text{max}} < 10$  MHz.

### 9.7.5.2.3 Minimum requirement for Band Category 2

For an MSR RIB operating in BC2 bands, the minimum requirements are specified in tables 9.7.5.2.3-1 to 9.7.5.2.3-8.

Applicability of Wide Area operating band unwanted emission requirements in tables 9.7.5.2.3-1, 9.7.5.2.3-1a and 9.7.5.2.3-1b is specified in table 9.7.5.2.3-0.

**Table 9.7.5.2.3-0: Applicability of operating band unwanted emission requirements for BC2 Wide Area BS**

NR band operation	UTRA supported	Applicable requirement table
None	Y/N	9.7.5.2.3-1 (option 2)
In certain regions (NOTE 2), bands 3, 8	N	9.7.5.2.3-1 (option 2)
Any below 1 GHz except for certain regions (NOTE 2), band 8	N	9.7.5.2.3-1a (option 1)
Any above 1 GHz except for certain regions (NOTE 2), band 3	N	9.7.5.2.3-1b (option 1)
NOTE 1: Void.		
NOTE 2: Applicable only for operation in regions where Category B limits as defined in ITU-R Recommendation SM.329 [14] are used for which category B option 2 operating band unwanted emissions requirements as defined in TS 36.104 [8] and TS 38.104 [27] are applied.		

**Table 9.7.5.2.3-1: WA BS OBUE in BC2 bands applicable for: BS not supporting NR; or BS supporting NR in Band n3 or n8**

Frequency offset of measurement filter -3dB point, $\Delta f$	Frequency offset of measurement filter centre frequency, $f_{\text{offset}}$	Minimum requirement (NOTE 2, 3)	Measurement bandwidth (NOTE 10)
$0 \text{ MHz} \leq \Delta f < 0.2 \text{ MHz}$ (NOTE 1)	$0.015 \text{ MHz} \leq f_{\text{offset}} < 0.215 \text{ MHz}$	-5 dBm	30 kHz
$0.2 \text{ MHz} \leq \Delta f < 1 \text{ MHz}$  (NOTE 9)	$0.215 \text{ MHz} \leq f_{\text{offset}} < 1.015 \text{ MHz}$  $1.015 \text{ MHz} \leq f_{\text{offset}} < 1.5 \text{ MHz}$	$-5 \text{ dBm} - 15 \cdot \left( \frac{f_{\text{offset}}}{\text{MHz}} - 0.215 \right) \text{ dB}$	30 kHz
$1 \text{ MHz} \leq \Delta f \leq \min(\Delta f_{\text{max}}, 10 \text{ MHz})$	$1.5 \text{ MHz} \leq f_{\text{offset}} < \min(f_{\text{offset}_{\text{max}}}, 10.5 \text{ MHz})$	-4 dBm	1 MHz
$10 \text{ MHz} \leq \Delta f \leq \Delta f_{\text{max}}$	$10.5 \text{ MHz} \leq f_{\text{offset}} < f_{\text{offset}_{\text{max}}}$	-6 dBm (NOTE 11)	1 MHz
NOTE 1: For operation with an E-UTRA 1.4 or 3 MHz carrier adjacent to the <i>Base Station RF Bandwidth edge</i> , the limits in table 9.7.5.2.3-2 apply for $0 \text{ MHz} \leq \Delta f < 0.15 \text{ MHz}$ .			
NOTE 2: For MSR RIB supporting <i>non-contiguous spectrum</i> operation within any operating band the <i>minimum requirement</i> within <i>sub-block gaps</i> is calculated as a cumulative sum of contributions from adjacent sub-blocks on each side of the <i>sub-block gap</i> , where the contribution from the far-end sub-block shall be scaled according to the measurement bandwidth of the near-end sub-block. Exception is $\Delta f \geq 10 \text{ MHz}$ from both adjacent sub-blocks on each side of the <i>sub-block gap</i> , where the <i>minimum requirement</i> within <i>sub-block gaps</i> shall be -6dBm/MHz.			
NOTE 3: For a MSR <i>multi-band RIB</i> with <i>Inter RF Bandwidth gap</i> $< 2 \times \Delta f_{\text{OBUE}}$ operation the <i>minimum requirement</i> within the <i>Inter RF Bandwidth gaps</i> is calculated as a cumulative sum of contributions from adjacent sub-blocks or <i>Base Station RF Bandwidth</i> on each side of the <i>Inter RF Bandwidth gap</i> , where the contribution from the far-end sub-block or <i>Base Station RF Bandwidth</i> shall be scaled according to the measurement bandwidth of the near-end sub-block or <i>Base Station RF Bandwidth</i> .			

**Table 9.7.5.2.3-1a: WA BS OBUE in BC2 bands  $\leq 1$  GHz applicable for: BS supporting NR, not operating in band n8, and not supporting UTRA**

Frequency offset of measurement filter -3dB point, $\Delta f$	Frequency offset of measurement filter centre frequency, $f_{\text{offset}}$	Minimum requirement (Note 1, 2)	Measurement bandwidth (Note 10)
$0 \text{ MHz} \leq \Delta f < 5 \text{ MHz}$	$0.05 \text{ MHz} \leq f_{\text{offset}} < 5.05 \text{ MHz}$	$2 \text{ dBm} - 7/5(f_{\text{offset}}/\text{MHz} - 0.05) \text{ dB}$	100 kHz
$5 \text{ MHz} \leq \Delta f < \min(10 \text{ MHz}, \Delta f_{\text{max}})$	$5.05 \text{ MHz} \leq f_{\text{offset}} < \min(10.05 \text{ MHz}, f_{\text{offset}_{\text{max}}})$	-5 dBm	100 kHz
$10 \text{ MHz} \leq \Delta f \leq \Delta f_{\text{max}}$	$10.05 \text{ MHz} \leq f_{\text{offset}} < f_{\text{offset}_{\text{max}}}$	-7 dBm (Note 11)	100 kHz
<p>NOTE 1: For MSR <i>RIB</i> supporting non-contiguous spectrum operation within any operating band, the <i>minimum requirement</i> within <i>sub-block gaps</i> is calculated as a cumulative sum of contributions from adjacent sub blocks on each side of the sub block gap. Exception is <math>\Delta f \geq 10\text{MHz}</math> from both adjacent sub blocks on each side of the <i>sub-block gap</i>, where the minimum requirement within sub-block gaps shall be -7 dBm/100 kHz.</p> <p>NOTE 2: For MSR <i>multi band RIB</i> with <i>Inter RF Bandwidth gap</i> <math>&lt; 2 \times \Delta f_{\text{OBUE}}</math> the minimum requirement within the <i>Inter RF Bandwidth gaps</i> is calculated as a cumulative sum of contributions from adjacent sub-blocks or RF Bandwidth on each side of the <i>Inter RF Bandwidth gap</i>.</p> <p>NOTE 3: For operation with an E-UTRA 1.4 or 3 MHz carrier adjacent to the <i>Base Station RF Bandwidth edge</i>, the limits in table 9.7.5.2.3-2 apply for <math>0 \text{ MHz} \leq \Delta f &lt; 0.15 \text{ MHz}</math>.</p>			

**Table 9.7.5.2.3-1b: WA BS OBUE in BC2 bands  $> 1$  GHz applicable for: BS supporting NR, not operating in band n3, and not supporting UTRA**

Frequency offset of measurement filter -3dB point, $\Delta f$	Frequency offset of measurement filter centre frequency, $f_{\text{offset}}$	Minimum requirement (Note 1, 2)	Measurement bandwidth (Note 10)
$0 \text{ MHz} \leq \Delta f < 5 \text{ MHz}$	$0.05 \text{ MHz} \leq f_{\text{offset}} < 5.05 \text{ MHz}$	$2 \text{ dBm} - 7/5(f_{\text{offset}}/\text{MHz} - 0.05) \text{ dB}$	100 kHz
$5 \text{ MHz} \leq \Delta f < \min(10 \text{ MHz}, \Delta f_{\text{max}})$	$5.05 \text{ MHz} \leq f_{\text{offset}} < \min(10.05 \text{ MHz}, f_{\text{offset}_{\text{max}}})$	-5 dBm	100 kHz
$10 \text{ MHz} \leq \Delta f \leq \Delta f_{\text{max}}$	$10.5 \text{ MHz} \leq f_{\text{offset}} < f_{\text{offset}_{\text{max}}}$	-7 dBm (Note 11)	1MHz
<p>NOTE 1: For MSR <i>RIBs</i> supporting non-contiguous spectrum operation within any operating band, the minimum requirement within <i>sub-block gaps</i> is calculated as a cumulative sum of contributions from adjacent sub blocks on each side of the <i>sub block gap</i>, where the contribution from the far-end sub-block shall be scaled according to the measurement bandwidth of the near-end sub-block. Exception is <math>\Delta f \geq 10\text{MHz}</math> from both adjacent sub blocks on each side of the <i>sub-block gap</i>, where the minimum requirement within sub-block gaps shall be -7dBm/1MHz.</p> <p>NOTE 2: For MSR <i>multi band RIB</i> with <i>Inter RF Bandwidth gap</i> <math>&lt; 2 \times \Delta f_{\text{OBUE}}</math> the minimum requirement within the <i>Inter RF Bandwidth gaps</i> is calculated as a cumulative sum of contributions from adjacent sub-blocks or RF Bandwidth on each side of the <i>Inter RF Bandwidth gap</i>, where the contribution from the far-end sub-block or RF Bandwidth shall be scaled according to the measurement bandwidth of the near-end sub-block or RF Bandwidth.</p> <p>NOTE 3: For operation with an E-UTRA 1.4 or 3 MHz carrier adjacent to the <i>Base Station RF Bandwidth edge</i>, the limits in table 9.7.5.2.3-2 apply for <math>0 \text{ MHz} \leq \Delta f &lt; 0.15 \text{ MHz}</math>.</p>			

**Table 9.7.5.2.3-2: WA BS OBUE in BC2 bands applicable for: BS operating with E-UTRA 1.4 or 3 MHz carriers adjacent to the *Base Station RF Bandwidth edge***

Frequency offset of measurement filter -3dB point, $\Delta f$	Frequency offset of measurement filter centre frequency, $f_{\text{offset}}$	Minimum requirement (NOTE 2, 3)	Measurement bandwidth (NOTE 10)
$0 \text{ MHz} \leq \Delta f < 0.05 \text{ MHz}$	$0.015 \text{ MHz} \leq f_{\text{offset}} < 0.065 \text{ MHz}$	$\text{Max}\left(14\text{dBm} - 60 \cdot \left(\frac{f_{\text{offset}}}{\text{MHz}} - 0.015\right) \text{dB}, -5\text{dBm}\right)$	30 kHz
$0.05 \text{ MHz} \leq \Delta f < 0.15 \text{ MHz}$	$0.065 \text{ MHz} \leq f_{\text{offset}} < 0.165 \text{ MHz}$	$\text{Max}\left(11\text{dBm} - 160 \cdot \left(\frac{f_{\text{offset}}}{\text{MHz}} - 0.065\right) \text{dB}, -5\text{dBm}\right)$	30 kHz

NOTE 1: The limits in this table only apply for operation with an E-UTRA 1.4 or 3 MHz carrier adjacent to the *Base Station RF Bandwidth edge*.

NOTE 2: For MSR RIB supporting *non-contiguous spectrum* operation within any operating band the *minimum requirement* within *sub-block gaps* is calculated as a cumulative sum of contributions from adjacent sub blocks on each side of the *sub-block gap*.

NOTE 3: For a MSR *multi-band RIB* with *Inter RF Bandwidth gap*  $< 2 \times \Delta f_{\text{OBUE}}$  the *minimum requirement* within the *Inter RF Bandwidth gaps* is calculated as a cumulative sum of contributions from adjacent sub-blocks or *Base Station RF Bandwidth* on each side of the *Inter RF Bandwidth gap*.

NOTE 4: (Void)

**Table 9.7.5.2.3-3: MR BS OBUE in BC2 bands applicable for: BS with maximum output power  $40 < P_{\text{rated,c,TRP}} \leq 47 \text{ dBm}$  and not supporting NR**

Frequency offset of measurement filter -3dB point, $\Delta f$	Frequency offset of measurement filter centre frequency, $f_{\text{offset}}$	Minimum requirement (NOTE 2, 3)	Measurement bandwidth (NOTE 10)
$0 \text{ MHz} \leq \Delta f < 0.6 \text{ MHz}$ (NOTE 1)	$0.015\text{MHz} \leq f_{\text{offset}} < 0.615\text{MHz}$	$P_{\text{rated,c,TRP}} - 58\text{dB} - (5/3) \cdot (f_{\text{offset}} - 0.015)\text{dB}$	30 kHz
$0.6 \text{ MHz} \leq \Delta f < 1 \text{ MHz}$ (NOTE 9)	$0.615\text{MHz} \leq f_{\text{offset}} < 1.015\text{MHz}$	$P_{\text{rated,c,TRP}} - 53\text{dB} - 15 \cdot (f_{\text{offset}} - 0.215)\text{dB}$	30 kHz
	$1.015\text{MHz} \leq f_{\text{offset}} < 1.5 \text{ MHz}$	$P_{\text{rated,c,TRP}} - 65 \text{ dB}$	30 kHz
$1 \text{ MHz} \leq \Delta f \leq 2.8 \text{ MHz}$	$1.5 \text{ MHz} \leq f_{\text{offset}} < 3.3 \text{ MHz}$	$P_{\text{rated,c,TRP}} - 52 \text{ dB}$	1 MHz
$2.8 \text{ MHz} \leq \Delta f \leq 5 \text{ MHz}$	$3.3 \text{ MHz} \leq f_{\text{offset}} < 5.5 \text{ MHz}$	$P_{\text{rated,c,TRP}} - 52 \text{ dB}, -6\text{dBm}$	1 MHz
$5 \text{ MHz} \leq \Delta f \leq \Delta f_{\text{max}}$	$5.5 \text{ MHz} \leq f_{\text{offset}} < f_{\text{offset}_{\text{max}}}$	$P_{\text{rated,c,TRP}} - 56 \text{ dB}$	1 MHz

NOTE 1: For operation with an E-UTRA 1.4 or 3 MHz carrier adjacent to the *Base Station RF Bandwidth edge*, the limits in table 9.7.5.2.3-5 apply for  $0 \text{ MHz} \leq \Delta f < 0.15 \text{ MHz}$ .

NOTE 2: For a MSR RIB supporting *non-contiguous spectrum* operation within any operating band the *minimum requirement* within *sub-block gaps* is calculated as a cumulative sum of contributions from adjacent sub blocks on each side of the *sub-block gap*, where the contribution from the far-end sub-block shall be scaled according to the measurement bandwidth of the near-end sub-block. Exception is  $\Delta f \geq 10\text{MHz}$  from both adjacent sub-blocks on each side of the *sub-block gap*, where the *minimum requirement* within *sub-block gaps* shall be  $(P_{\text{rated,c,TRP}} - 56 \text{ dB})/\text{MHz}$ .

NOTE 3: For a MSR *multi-band RIB* with *Inter RF Bandwidth gap*  $< 2 \times \Delta f_{\text{OBUE}}$  the *minimum requirement* within the *Inter RF Bandwidth gaps* is calculated as a cumulative sum of contributions from adjacent sub-blocks or *Base Station RF Bandwidth* on each side of the *Inter RF Bandwidth gap*, where the contribution from the far-end sub-block or *Base Station RF Bandwidth* shall be scaled according to the measurement bandwidth of the near-end sub-block or *Base Station RF Bandwidth*.

**Table 9.7.5.2.3-3a: MR BS OBUE in BC2 bands applicable for: BS with maximum output power 40 <math>P\_{\text{rated,c,TRP}} \leq 47 \text{ dBm}</math>, supporting NR and not supporting UTRA**

Frequency offset of measurement filter -3dB point, $\Delta f$	Frequency offset of measurement filter centre frequency, $f_{\text{offset}}$	Minimum requirement (Note 1, 2)	Measurement bandwidth (Note 10)
$0 \text{ MHz} \leq \Delta f < 5 \text{ MHz}$	$0.05 \text{ MHz} \leq f_{\text{offset}} < 5.05 \text{ MHz}$	$P_{\text{rated,c,TRP}} - 53 \text{ dB} - (7/5) \cdot (f_{\text{offset}} - 0.05) \text{ dB}$	100 kHz
$5 \text{ MHz} \leq \Delta f < \min(10 \text{ MHz}, \Delta f_{\text{max}})$	$5.05 \text{ MHz} \leq f_{\text{offset}} < \min(10.05 \text{ MHz}, f_{\text{offset,max}})$	$P_{\text{rated,c,TRP}} - 60 \text{ dB}$	100 kHz
$10 \text{ MHz} \leq \Delta f \leq \Delta f_{\text{max}}$	$10.05 \text{ MHz} \leq f_{\text{offset}} < f_{\text{offset,max}}$	$\text{Min}(P_{\text{rated,c,TRP}} - 60 \text{ dB}, -16 \text{ dBm})$ (Note 1)	100 kHz

NOTE 1: For MSR RIBs supporting non-contiguous spectrum operation within any operating band the minimum requirement within *sub-block gaps* is calculated as a cumulative sum of contributions from adjacent sub blocks on each side of the *sub-block gap*. Exception is  $\Delta f \geq 10 \text{ MHz}$  from both adjacent sub blocks on each side of the *sub-block gap*, where the minimum requirement within sub-block gaps shall be  $\text{Min}(P_{\text{rated,c,TRP}} - 60 \text{ dB}, -16 \text{ dBm})/100 \text{ kHz}$ .

NOTE 2: For MSR multi band RIB with *Inter RF Bandwidth gap*  $< 2 \times \Delta f_{\text{OBUE}}$  the minimum requirement within the *Inter RF Bandwidth gaps* is calculated as a cumulative sum of contributions from adjacent sub-blocks or *RF Bandwidth* on each side of the *Inter RF Bandwidth gap*.

NOTE 3: For operation with an E-UTRA 1.4 or 3 MHz carrier adjacent to the *Base Station RF Bandwidth edge*, the limits in table 9.7.5.2.3-5 apply for  $0 \text{ MHz} \leq \Delta f < 0.15 \text{ MHz}$ .

**Table 9.7.5.2.3-4: MR BS OBUE in BC2 bands applicable for: BS with maximum output power  $P_{\text{rated,c,TRP}} \leq 40 \text{ dBm}$  and not supporting NR**

Frequency offset of measurement filter -3dB point, $\Delta f$	Frequency offset of measurement filter centre frequency, $f_{\text{offset}}$	Minimum requirement (NOTE 2, 3)	Measurement bandwidth (NOTE 10)
$0 \text{ MHz} \leq \Delta f < 0.6 \text{ MHz}$ (NOTE 1)	$0.015 \text{ MHz} \leq f_{\text{offset}} < 0.615 \text{ MHz}$	$-1 \text{ dBm} - \frac{5}{3} \cdot \left( \frac{f_{\text{offset}}}{\text{MHz}} - 0.015 \right) \text{ dB}$	30 kHz
$0.6 \text{ MHz} \leq \Delta f < 1 \text{ MHz}$	$0.615 \text{ MHz} \leq f_{\text{offset}} < 1.015 \text{ MHz}$	$-13 \text{ dBm} - 15 \cdot \left( \frac{f_{\text{offset}}}{\text{MHz}} - 0.215 \right) \text{ dB}$	30 kHz
(NOTE 9)	$1.015 \text{ MHz} \leq f_{\text{offset}} < 1.5 \text{ MHz}$	-25 dBm	30 kHz
$1 \text{ MHz} \leq \Delta f \leq 5 \text{ MHz}$	$1.5 \text{ MHz} \leq f_{\text{offset}} < 5.5 \text{ MHz}$	-12 dBm	1 MHz
$5 \text{ MHz} \leq \Delta f \leq \Delta f_{\text{max}}$	$5.5 \text{ MHz} \leq f_{\text{offset}} < f_{\text{offset,max}}$	-16 dBm	1 MHz

NOTE 1: For operation with an E-UTRA 1.4 or 3 MHz carrier adjacent to the *Base Station RF Bandwidth edge*, the limits in table 6.6.2.2-6 apply for  $0 \text{ MHz} \leq \Delta f < 0.15 \text{ MHz}$ .

NOTE 2: For a MSR RIB supporting *non-contiguous spectrum* operation within any operating band the *minimum requirement* within *sub-block gaps* is calculated as a cumulative sum of contributions from adjacent sub blocks on each side of the *sub-block gap*, where the contribution from the far-end sub-block shall be scaled according to the measurement bandwidth of the near-end sub-block. Exception is  $\Delta f \geq 10 \text{ MHz}$  from both adjacent sub-blocks on each side of the *sub-block gap*, where the *minimum requirement* within *sub-block gaps* shall be  $-16 \text{ dBm/MHz}$ .

NOTE 3: For a MSR multi-band RIB with *Inter RF Bandwidth gap*  $< 2 \times \Delta f_{\text{OBUE}}$  the *minimum requirement* within the *Inter RF Bandwidth gaps* is calculated as a cumulative sum of contributions from adjacent sub-blocks or *Base Station RF Bandwidth* on each side of the *Inter RF Bandwidth gap*, where the contribution from the far-end sub-block or *Base Station RF Bandwidth* shall be scaled according to the measurement bandwidth of the near-end sub-block or *Base Station RF Bandwidth*.

**Table 9.7.5.2.3-4a: MR BS OBUE in BC2 bands applicable for: BS maximum output power  $P_{\text{rated,c,TRP}} \leq 40$  dBm, supporting NR and not supporting UTRA**

Frequency offset of measurement filter -3dB point, $\Delta f$	Frequency offset of measurement filter centre frequency, $f_{\text{offset}}$	Minimum requirement (Note 1, 2)	Measurement bandwidth (Note 10)
$0 \text{ MHz} \leq \Delta f < 5 \text{ MHz}$	$0.05 \text{ MHz} \leq f_{\text{offset}} < 5.05 \text{ MHz}$	$-13 \text{ dBm} - 7/5(f_{\text{offset}}/\text{MHz} - 0.05) \text{ dB}$	100 kHz
$5 \text{ MHz} \leq \Delta f < \min(10 \text{ MHz}, \Delta f_{\text{max}})$	$5.05 \text{ MHz} \leq f_{\text{offset}} < \min(10.05 \text{ MHz}, f_{\text{offset}_{\text{max}}})$	-20 dBm	100 kHz
$10 \text{ MHz} \leq \Delta f \leq \Delta f_{\text{max}}$	$10.05 \text{ MHz} \leq f_{\text{offset}} < f_{\text{offset}_{\text{max}}}$	-20 dBm (Note 11)	100 kHz
<p>NOTE 1: For MSR RIBs supporting non-contiguous spectrum operation within any operating band the minimum requirement within <i>sub-block gaps</i> is calculated as a cumulative sum of contributions from adjacent sub blocks on each side of the <i>sub-block gap</i>. Exception is <math>\Delta f \geq 10\text{MHz}</math> from both adjacent sub blocks on each side of the <i>sub-block gap</i>, where the minimum requirement within sub-block gaps shall be -20 dBm/100 kHz.</p> <p>NOTE 2: For MSR <i>multi band TAB connector</i> with <i>Inter RF Bandwidth gap</i> <math>&lt; 2 \times \Delta f_{\text{OBUE}}</math> the minimum requirement within the <i>Inter RF Bandwidth gaps</i> is calculated as a cumulative sum of contributions from adjacent sub-blocks or <i>RF Bandwidth</i> on each side of the <i>Inter RF Bandwidth gap</i>.</p> <p>NOTE 3: For operation with an E-UTRA 1.4 or 3 MHz carrier adjacent to the <i>Base Station RF Bandwidth edge</i>, the limits in table 9.7.5.2.3-6 apply for <math>0 \text{ MHz} \leq \Delta f &lt; 0.15 \text{ MHz}</math>.</p>			

**Table 9.7.5.2.3-5: MR BS OBUE in BC2 bands applicable for: BS with maximum output power  $40 < P_{\text{rated,c,TRP}} \leq 47$  dBm and operating with E-UTRA 1.4 or 3 MHz carriers adjacent to the *Base Station RF Bandwidth edge***

Frequency offset of measurement filter -3dB point, $\Delta f$	Frequency offset of measurement filter centre frequency, $f_{\text{offset}}$	Minimum requirement (NOTE 2, 3)	Measurement bandwidth (NOTE 10)
$0 \text{ MHz} \leq \Delta f < 0.05 \text{ MHz}$	$0.015 \text{ MHz} \leq f_{\text{offset}} < 0.065 \text{ MHz}$	$P_{\text{rated,c,TRP}} - 38\text{dB} - 60 \cdot (f_{\text{offset}} - 0,015)\text{dB}$	30 kHz
$0.05 \text{ MHz} \leq \Delta f < 0.15 \text{ MHz}$	$0.065 \text{ MHz} \leq f_{\text{offset}} < 0.165 \text{ MHz}$	$P_{\text{rated,c,TRP}} - 41\text{dB} - 160 \cdot (f_{\text{offset}} - 0,065)\text{dB}$	30 kHz
<p>NOTE 1: The limits in this table only apply for operation with an E-UTRA 1.4 or 3 MHz carrier adjacent to the <i>Base Station RF Bandwidth edge</i>.</p> <p>NOTE 2: For a MSR RIB supporting <i>non-contiguous spectrum</i> operation within any operating band the <i>minimum requirement</i> within <i>sub-block gaps</i> is calculated as a cumulative sum of contributions from adjacent sub blocks on each side of the <i>sub-block gap</i>.</p> <p>NOTE 3: For a MSR <i>multi-band RIB</i> with <i>Inter RF Bandwidth gap</i> <math>&lt; 2 \times \Delta f_{\text{OBUE}}</math> the <i>minimum requirement</i> within the <i>Inter RF Bandwidth gaps</i> is calculated as a cumulative sum of contributions from adjacent sub-blocks or <i>Base Station RF Bandwidth</i> on each side of the <i>Inter RF Bandwidth gap</i>.</p>			

**Table 9.7.5.2.3-6: MR BS OBUE in BC2 bands applicable for: BS with maximum output power  $P_{\text{rated,c,TRP}} \leq 40$  dBm and operating E-UTRA 1.4 or 3 MHz carriers adjacent to the *Base Station RF Bandwidth edge***

Frequency offset of measurement filter -3dB point, $\Delta f$	Frequency offset of measurement filter centre frequency, $f_{\text{offset}}$	Minimum requirement (NOTE 2, 3)	Measurement bandwidth (NOTE 10)
$0 \text{ MHz} \leq \Delta f < 0.05 \text{ MHz}$	$0.015 \text{ MHz} \leq f_{\text{offset}} < 0.065 \text{ MHz}$	$Max(2dBm - 60 \cdot \left(\frac{f_{\text{offset}}}{\text{MHz}} - 0.015\right) dB, -18dBm)$	30 kHz
$0.05 \text{ MHz} \leq \Delta f < 0.15 \text{ MHz}$	$0.065 \text{ MHz} \leq f_{\text{offset}} < 0.165 \text{ MHz}$	$Max(-1dBm - 160 \cdot \left(\frac{f_{\text{offset}}}{\text{MHz}} - 0.065\right) dB, -18dBm)$	30 kHz

NOTE 1: The limits in this table only apply for operation with an E-UTRA 1.4 or 3 MHz carrier adjacent to the *Base Station RF Bandwidth edge*.

NOTE 2: For a MSR RIB supporting *non-contiguous spectrum* operation within any operating band the *minimum requirement* within *sub-block gaps* is calculated as a cumulative sum of contributions from adjacent sub blocks on each side of the *sub-block gap*.

NOTE 3: For a MSR *multi-band RIB* with *Inter RF Bandwidth gap*  $< 2 \times \Delta f_{\text{OBUE}}$  the *minimum requirement* within the *Inter RF Bandwidth gaps* is calculated as a cumulative sum of contributions from adjacent sub-blocks or *Base Station RF Bandwidth* on each side of the *Inter RF Bandwidth gap*.

NOTE 4: (Void)

**Table 9.7.5.2.3-7: LA BS OBUE in BC2 bands**

Frequency offset of measurement filter -3dB point, $\Delta f$	Frequency offset of measurement filter centre frequency, $f_{\text{offset}}$	Minimum requirement (NOTE 2, 3)	Measurement bandwidth (NOTE 10)
$0 \text{ MHz} \leq \Delta f < 5 \text{ MHz}$ (NOTE 1)	$0.05 \text{ MHz} \leq f_{\text{offset}} < 5.05 \text{ MHz}$	$-21dBm - \frac{7}{5} \left(\frac{f_{\text{offset}}}{\text{MHz}} - 0.05\right) dB$	100 kHz
$5 \text{ MHz} \leq \Delta f < \min(10 \text{ MHz}, \Delta f_{\text{max}})$	$5.05 \text{ MHz} \leq f_{\text{offset}} < \min(10.05 \text{ MHz}, f_{\text{offset}_{\text{max}}})$	-28 dBm	100 kHz
$10 \text{ MHz} \leq \Delta f \leq \Delta f_{\text{max}}$	$10.05 \text{ MHz} \leq f_{\text{offset}} < f_{\text{offset}_{\text{max}}}$	-28 dBm (NOTE 11)	100 kHz

NOTE 1: For operation with an E-UTRA 1.4 or 3 MHz carrier adjacent to the *Base Station RF Bandwidth edge*, the limits in table 9.7.5.2.3-8 apply for  $0 \text{ MHz} \leq \Delta f < 0.16 \text{ MHz}$ .

NOTE 2: For a MSR RIB supporting *non-contiguous spectrum* operation within any operating band the *minimum requirement* within *sub-block gaps* is calculated as a cumulative sum of contributions from adjacent sub blocks on each side of the *sub-block gap*. Exception is  $\Delta f \geq 10 \text{ MHz}$  from both adjacent sub blocks on each side of the *sub-block gap*, where the *minimum requirement* within *sub-block gaps* shall be -28dBm/100 kHz.

NOTE 3: For a MSR *multi-band RIB* with *Inter RF Bandwidth gap*  $< 2 \times \Delta f_{\text{OBUE}}$  the *minimum requirement* within the *Inter RF Bandwidth gaps* is calculated as a cumulative sum of contributions from adjacent sub-blocks or *Base Station RF Bandwidth* on each side of the *Inter RF Bandwidth gap*.

**Table 9.7.5.2.3-8: LA BS OBUE for operation in BC2 bands applicable for: BS operating with E-UTRA 1.4 or 3 MHz carriers adjacent to the *Base Station RF Bandwidth edge***

Frequency offset of measurement filter -3dB point, $\Delta f$	Frequency offset of measurement filter centre frequency, $f_{\text{offset}}$	Minimum requirement (NOTE 2, 3)	Measurement bandwidth (NOTE 10)
$0 \text{ MHz} \leq \Delta f < 0.05 \text{ MHz}$	$0.015 \text{ MHz} \leq f_{\text{offset}} < 0.065 \text{ MHz}$	$\text{Max}\left(-5\text{dBm} - 60 \cdot \left(\frac{f_{\text{offset}}}{\text{MHz}} - 0.015\right) \text{dB}, -26\text{dBm}\right)$	30 kHz
$0.05 \text{ MHz} \leq \Delta f < 0.16 \text{ MHz}$	$0.065 \text{ MHz} \leq f_{\text{offset}} < 0.175 \text{ MHz}$	$\text{Max}\left(-8\text{dBm} - 160 \cdot \left(\frac{f_{\text{offset}}}{\text{MHz}} - 0.065\right) \text{dB}, -26\text{dBm}\right)$	30 kHz
<p>NOTE 1: The limits in this table only apply for operation with an E-UTRA 1.4 or 3 MHz carrier adjacent to the <i>Base Station RF Bandwidth edge</i>.</p> <p>NOTE 2: For a MSR RIB supporting <i>non-contiguous spectrum</i> operation within any operating band the <i>minimum requirement</i> within <i>sub-block gaps</i> is calculated as a cumulative sum of contributions from adjacent sub blocks on each side of the <i>sub-block gap</i>.</p> <p>NOTE 3: For a MSR <i>multi-band RIB</i> with <i>Inter RF Bandwidth gap</i> <math>&lt; 2 \times \Delta f_{\text{OBUE}}</math> the <i>minimum requirement</i> within the <i>Inter RF Bandwidth gaps</i> is calculated as a cumulative sum of contributions from adjacent sub-blocks or <i>Base Station RF Bandwidth</i> on each side of the <i>Inter RF Bandwidth gap</i>.</p> <p>NOTE 4: (Void)</p>			

The following notes are common to all subclauses in 9.7.5.2.3:

NOTE 9: This frequency range ensures that the range of values of  $f_{\text{offset}}$  is continuous.

NOTE 10: As a general rule for the requirements in the present subclause, the resolution bandwidth of the measuring equipment should be equal to the measurement bandwidth. However, to improve measurement accuracy, sensitivity and efficiency, the resolution bandwidth may be smaller than the measurement bandwidth. When the resolution bandwidth is smaller than the measurement bandwidth, the result should be integrated over the measurement bandwidth in order to obtain the equivalent noise bandwidth of the measurement bandwidth.

NOTE 11: The requirement is not applicable when  $\Delta f_{\text{max}} < 10 \text{ MHz}$ .

NOTE 12: All limits in table 9.7.5.2.3-1, table 9.7.5.2.3-3, table 9.7.5.2.3-4 and table 9.7.5.2.3-7 are identical to the corresponding limits for Band Category 1 and 3.

## 9.7.5.2.4 Additional requirements

### 9.7.5.2.4.1 Limits in FCC Title 47

In addition to the AAS BS may have to comply with the applicable emission limits established by FCC Title 47 [8], when deployed in regions where those limits are applied, and under the conditions declared by the manufacturer.

### 9.7.5.2.4.2 Unsynchronized operation for BC3

In certain regions, the following requirements may apply to a TDD AAS BS operating in BC3 in the same geographic area and in the same operating band as another TDD system without synchronisation. For this case the emissions shall not exceed -52 dBm/MHz in each supported *downlink operating band* except in:

- The frequency range from  $\Delta f_{\text{OBUE}}$  below the lower *Base Station RF Bandwidth edge* to the frequency  $\Delta f_{\text{OBUE}}$  above the upper *Base Station RF Bandwidth edge* of each supported band.

NOTE 1: Local or regional regulations may specify another excluded frequency range, which may include frequencies where synchronised TDD systems operate.

NOTE 2: TDD base stations that are synchronized and operating in BC3 can transmit without these additional co-existence requirements.

9.7.5.2.4.3 Protection of DTT

In certain regions the following requirement may apply for protection of DTT. For an AAS BS operating in Band 20, the level of emissions in the band 470-790 MHz, measured in an 8 MHz filter bandwidth on centre frequencies  $F_{\text{filter}}$  according to table 9.7.5.2.4.3-1, shall not exceed the maximum emission TRP level shown in the table. This requirement applies in the frequency range 470-790 MHz even though part of the range falls in the spurious domain.

**Table 9.7.5.2.4.3-1: Declared emissions levels for protection of DTT**

Case	Measurement filter centre frequency	Condition on BS maximum aggregate TRP / 10 MHz, $P_{\text{TRP\_10MHz}}$ (NOTE)	Maximum Level $P_{\text{TRP,N,MAX}}$	Measurement Bandwidth
A: for DTT frequencies where broadcasting is protected	$N*8 + 306 \text{ MHz}, 21 \leq N \leq 60$	$P_{\text{TRP\_10MHz}} \geq 59 \text{ dBm}$	0 dBm	8 MHz
	$N*8 + 306 \text{ MHz}, 21 \leq N \leq 60$	$36 \leq P_{\text{TRP\_10MHz}} < 59 \text{ dBm}$	$P_{\text{TRP\_10MHz}} - 59 \text{ dBm}$	8 MHz
	$N*8 + 306 \text{ MHz}, 21 \leq N \leq 60$	$P_{\text{TRP\_10MHz}} < 36 \text{ dBm}$	-23 dBm	8 MHz
B: for DTT frequencies where broadcasting is subject to an intermediate level of protection	$N*8 + 306 \text{ MHz}, 21 \leq N \leq 60$	$P_{\text{TRP\_10MHz}} \geq 59 \text{ dBm}$	10 dBm	8 MHz
	$N*8 + 306 \text{ MHz}, 21 \leq N \leq 60$	$36 \leq P_{\text{TRP\_10MHz}} < 59 \text{ dBm}$	$P_{\text{TRP\_10MHz}} - 49 \text{ dBm}$	8 MHz
	$N*8 + 306 \text{ MHz}, 21 \leq N \leq 60$	$P_{\text{TRP\_10MHz}} < 36 \text{ dBm}$	-13 dBm	8 MHz
C: for DTT frequencies where broadcasting is not protected	$N*8 + 306 \text{ MHz}, 21 \leq N \leq 60$	N.A.	22 dBm	8 MHz
NOTE: $P_{\text{TRP\_10MHz}}$ (dBm) is defined by the expression $P_{\text{TRP\_10MHz}} = P_{10\text{MHz}} + G_{\text{ant}} + 6\text{dB}$ for UTRA and $P_{\text{TRP\_10MHz}} = P_{10\text{MHz}} + G_{\text{ant}} + 9\text{dB}$ for E-UTRA, where $G_{\text{ant}}$ is 17 dBi				

NOTE: The regional requirement is defined in terms of EIRP (effective isotropic radiated power), which is dependent on both the BS emissions and the deployment (including antenna gain and feeder loss). The method outlined in annex B1 Indicates how the limit in table 5.2.4.3-1 demonstrates compliance to the regional requirement.

9.7.5.2.4.4 Void

**Table 9.7.5.2.4.4-1: Void**

9.7.5.2.4.5 Co-existence with RNSS/GPS services in North America

In regions where FCC regulation applies, requirements for protection of GPS according to FCC Order DA 20-48 applies for operation in Band 24. The following normative requirement covers the base station, to be used together with other information about the site installation to verify compliance with the requirement in FCC Order DA 20-48. The requirement applies to BS operating in Band 24 to ensure that appropriate interference protection is provided to the GPS. This requirement applies in the frequency range 1541-1650 MHz even though part of the range falls in the spurious domain.

The level of emissions in the 1541 – 1650 MHz band, measured in measurement bandwidth according to table 9.7.5.2.4.5-1 shall not exceed the maximum TRP limits indicated in the table.

**Table 9.7.5.2.4.5-1: Emissions levels for protection of the 1541-1650 MHz band**

Operating Band	Frequency range (MHz)	Emission level (dBW) (Measurement bandwidth = 1 MHz)	Emission level (dBW) of discrete emissions of less than 700 Hz bandwidth (Measurement bandwidth = 1 kHz)	Emission level (dBW) of discrete emissions of less than 2 kHz bandwidth (Measurement bandwidth = 1 kHz)
24	1541 - 1559	$P_{EIRP} - 17 \text{ dBi} + 9 \text{ dB}$		$P_{EIRP} - 17 \text{ dBi} + 9 \text{ dB}$
	1559 - 1610	$P_{EIRP} - 17 \text{ dBi} + 9 \text{ dB}$	$P_{EIRP} - 17 \text{ dBi} + 9 \text{ dB}$	
	1610 - 1650	$P_{EIRP} - 17 \text{ dBi} + 9 \text{ dB}$	$P_{EIRP} - 17 \text{ dBi} + 9 \text{ dB}$	

NOTE: The regional requirements, included in FCC Order DA 20-48 are defined in terms of EIRP (effective isotropic radiated power), which is dependent on both the BS emissions at the antenna connector and the deployment (including antenna gain and feeder loss). The method outlined in annex B1 indicates how the limit in table 9.7.5.2.4.5-1 demonstrates compliance to the regional requirement.  $P_{EIRP}$  values in table 9.7.5.2.4.5-1 are the effective isotropic power (or radiated power spectral density) set in the FCC Order DA 20-48 for the specified frequency ranges and bandwidths.

9.7.5.2.4.6 Void

**Table 9.7.5.2.4.6-1: Void**

9.7.5.2.4.7 Additional band 32, 50, 51, 74, 75 and 76 unwanted emissions

In certain regions, the following requirements may apply to BS operating in Band 32 within 1452-1492 MHz, in Band 75 within 1432-1517 MHz and in Band 76 within 1427-1432 MHz. The maximum level of operating band unwanted emissions, measured as EIRP, on centre frequencies  $f_{\text{offset}}$  with filter bandwidth, according to table 9.7.5.2.4.7-1, shall not exceed the EIRP limits indicated in the table.

For Band 32, this requirement applies in the frequency range 1452-1492 MHz when non-Mobile/Fixed Communications Network (MFCN) services are deployed in adjacent frequency ranges, while it applies also within 1427-1452 MHz and/or 1492-1517 MHz when MFCN services are deployed in such frequency ranges, even though part of the ranges falls in the spurious domain. For Band 75, this requirement applies in the frequency range 1427-1517 MHz. For Band 76, this requirement applies in the frequency range 1432-1517 MHz even though part of the range falls in the spurious domain.

omain.

**Table 9.7.5.2.4.7-1: Unwanted emission limits within 1427-1517 MHz**

Frequency offset of measurement filter centre frequency, $f_{\text{offset}}$	EIRP limit [dBm]	Measurement bandwidth
2.5 MHz	16.3	5 MHz
7.5 MHz	11	5 MHz
$12.5 \text{ MHz} \leq f_{\text{offset}} \leq f_{\text{offset}_{\text{max}}}$	9	5 MHz
NOTE: For Band 32, when non-MFCN services are deployed in the adjacent bands, $f_{\text{offset}_{\text{max}}}$ denotes the frequency difference between the lower Base Station RF Bandwidth edge and 1454.5 MHz, and the frequency difference between the upper Base Station RF Bandwidth edge and 1489.5 MHz for the set channel position. For Band 32, when MFCN services are deployed in the adjacent frequencies, Band 75 and Band 76, $f_{\text{offset}_{\text{max}}}$ denotes the frequency difference between the lower Base Station RF Bandwidth edge and 1429.5 MHz, and the frequency difference between the upper Base Station RF Bandwidth edge and 1514.5 MHz for the set channel position.		

In certain regions, the following requirement may apply to BS operating in Band 32 within 1452-1492MHz for the protection of non-MFCN services in spectrum adjacent to the frequency range 1452-1492 MHz. The maximum level of emissions, measured as EIRP, on centre frequencies  $F_{\text{filter}}$  with filter bandwidth according to Table 9.7.5.2.4.7-2, shall

not exceed the EIRP limits indicated in the table. This requirement applies in the frequency range 1429-1518 MHz even though part of the range falls in the spurious domain.

**Table 9.7.5.2.4.7-2: Unwanted emission limits outside 1452-1492 MHz**

Filter centre frequency, $F_{\text{filter}}$	EIRP limit [dBm]	Measurement bandwidth
$1429.5 \text{ MHz} \leq F_{\text{filter}} \leq 1448.5 \text{ MHz}$	20	1 MHz
$F_{\text{filter}} = 1450.5 \text{ MHz}$	14	3 MHz
$F_{\text{filter}} = 1493.5 \text{ MHz}$	14	3 MHz
$1495.5 \text{ MHz} \leq F_{\text{filter}} \leq 1517.5 \text{ MHz}$	20	1 MHz

In certain regions, the following requirement may apply to BS operating in Band 50 and Band 75 within 1492-1517 MHz and in Band 74 within 1492-1518 MHz. The maximum level of emissions, measured as EIRP, on centre frequencies  $F_{\text{filter}}$  with filter bandwidth according to table 9.7.5.2.4.7-3, shall not exceed the EIRP limits indicated in the table.

**Table 9.7.5.2.4.7-3: Operating band 50, 74 and 75 emission test limits above 1518 MHz**

Filter centre frequency, $F_{\text{filter}}$	EIRP limit (dBm)	Measurement bandwidth
$1518.5 \text{ MHz} \leq F_{\text{filter}} \leq 1519.5 \text{ MHz}$	-0.8	1 MHz
$1520.5 \text{ MHz} \leq F_{\text{filter}} \leq 1558.5 \text{ MHz}$	-30	1 MHz

In certain regions, the following requirement may apply to E-UTRA BS operating in Band 50 and Band 75 within 1432-1452 MHz, and in Band 51 and Band 76. Emissions shall not exceed the maximum levels specified in table 9.7.5.2.4.7-4.

**Table 9.7.5.2.4.7-4: Additional emission limits for BS operating in Band 50 and 75 within 1432-1452 MHz, and in Band 51 and 76**

Filter centre frequency, $F_{\text{filter}}$	Maximum Level [dBm]	Measurement Bandwidth
$F_{\text{filter}} = 1413.5 \text{ MHz}$	-42	27 MHz

#### 9.7.5.2.4.8 Additional requirements for band 45

In certain regions the following requirement may apply to E-UTRA BS operating in Band 45. Emissions shall not exceed the maximum levels specified in table 9.7.5.2.4.8-1.

**Table 9.7.5.2.4.8-1: Emissions limits for protection of adjacent band services**

Operating Band	Filter centre frequency, $F_{\text{filter}}$	Maximum Level [dBm]	Measurement Bandwidth
45	$F_{\text{filter}} = 1467.5$	-11	1 MHz
	$F_{\text{filter}} = 1468.5$	-14	1 MHz
	$F_{\text{filter}} = 1469.5$	-17	1 MHz
	$F_{\text{filter}} = 1470.5$	-24	1 MHz
	$F_{\text{filter}} = 1471.5$	-31	1 MHz
	$1472.5 \text{ MHz} \leq F_{\text{filter}} \leq 1491.5 \text{ MHz}$	-38	1 MHz

#### 9.7.5.2.4.9 Additional requirements for band 48

The following requirement may apply to BS operating in Band 48 in certain regions. Emissions shall not exceed the maximum levels specified in table 9.7.5.2.4.9-1.

**Table 9.7.5.2.4.9-1: Additional operating band unwanted emission limits for Band 48**

Channel bandwidth	Frequency offset of measurement filter -3dB point, $\Delta f$	Frequency offset of measurement filter centre frequency, $f_{\text{offset}}$	Minimum requirement	Measurement bandwidth
All	$0 \text{ MHz} \leq \Delta f < 10 \text{ MHz}$	$0.5 \text{ MHz} \leq f_{\text{offset}} < 9.5 \text{ MHz}$	-4 dBm	1 MHz

#### 9.7.5.2.4.10 Additional requirements for band 53

The following requirement may apply to BS operating in Band 53 in certain regions. Emissions shall not exceed the maximum levels specified in table 9.7.5.2.4.10-1.

**Table 9.7.5.2.4.10 -1: Additional operating band unwanted emission limits for Band 53**

Channel bandwidth [MHz]	Frequency range [MHz]	Frequency offset of measurement filter -3dB point, $\Delta f$	Frequency offset of measurement filter centre frequency, $f_{\text{offset}}$	Minimum requirement	Measurement bandwidth
1.4, 3, 5	2400 - 2477.5	$6 \text{ MHz} \leq \Delta f < 83.5 \text{ MHz}$	$6.5 \text{ MHz} \leq f_{\text{offset}} < 83 \text{ MHz}$	-16 dBm	1 MHz
10	2400 - 2473.5	$10 \text{ MHz} \leq \Delta f < 83.5 \text{ MHz}$	$10.5 \text{ MHz} \leq f_{\text{offset}} < 83 \text{ MHz}$	-16 dBm	1 MHz
1.4, 3, 5	2477.5 - 2478.5	$5 \text{ MHz} \leq \Delta f < 6 \text{ MHz}$	5.5 MHz	-4 dBm	1 MHz
10	2473.5 - 2478.5	$5 \text{ MHz} \leq \Delta f < 10 \text{ MHz}$	$5.5 \text{ MHz} \leq f_{\text{offset}} < 9.5 \text{ MHz}$	-4 dBm	1 MHz
All	2478.5 - 2483.5	$0 \text{ MHz} \leq \Delta f < 5 \text{ MHz}$	$0.5 \text{ MHz} \leq f_{\text{offset}} < 4.5 \text{ MHz}$	-1 dBm	1 MHz
1.4, 3, 5	2495 - 2501	$0 \text{ MHz} \leq \Delta f < 6 \text{ MHz}$	$0.5 \text{ MHz} \leq f_{\text{offset}} < 5.5 \text{ MHz}$	-4 dBm	1 MHz
10	2495 - 2505	$0 \text{ MHz} \leq \Delta f < 10 \text{ MHz}$	$0.5 \text{ MHz} \leq f_{\text{offset}} < 9.5 \text{ MHz}$	-4 dBm	1 MHz
1.4, 3, 5	2501 - 2690	$6 \text{ MHz} \leq \Delta f < 195 \text{ MHz}$	$6.5 \text{ MHz} \leq f_{\text{offset}} < 194.5 \text{ MHz}$	-16 dBm	1 MHz
10	2505 - 2690	$10 \text{ MHz} \leq \Delta f < 195 \text{ MHz}$	$10.5 \text{ MHz} \leq f_{\text{offset}} < 194.5 \text{ MHz}$	-16 dBm	1 MHz

#### 9.7.5.3 Minimum requirement for single RAT UTRA operation

There is no operating band unwanted emission requirement for a single RAT UTRA FDD AAS BS.

#### 9.7.5.4 Minimum requirement for single RAT E-UTRA operation

##### 9.7.5.4.1 General

The single RAT E-UTRA operating band unwanted emission minimum requirements are given in subclauses 9.7.5.4.2, 9.7.5.4.3, 9.7.5.4.4, 9.7.5.4.5 and 9.7.5.4.6.

For an AAS BS of Wide Area BS class, the requirements of either subclause 9.7.5.4.2 (Category A limits) or subclause 9.7.5.4.3 (Category B limits) shall apply.

For an AAS BS of Local Area BS class, the requirements of subclause 9.7.5.4.4 shall apply (Category A and B).

For an AAS BS of Medium Range BS class, the requirements in subclause 9.7.5.4.5 shall apply (Category A and B).

The application of either Category A or Category B limits shall be the same as for Transmitter spurious emissions (Mandatory Requirements) in subclause 9.7.6.

## 9.7.5.4.2 Minimum requirements for Wide Area BS (Category A)

For E-UTRA RIB operating in Bands 5, 6, 8, 12, 13, 14, 17, 18, 19, 26, 27, 28, 29, 31, 44, 68, 71, 72, 73, 85, 87, 88 the *minimum requirements* are specified in tables 9.7.5.4.2-1 to 9.7.5.4.2-3.

**Table 9.7.5.4.2-1: Wide Area BS operating band unwanted emission limits for 1.4 MHz channel bandwidth (E-UTRA bands <1GHz) for Category A**

Frequency offset of measurement filter -3dB point, $\Delta f$	Frequency offset of measurement filter centre frequency, $f_{\text{offset}}$	Minimum requirement (NOTE 1, 2)	Measurement bandwidth (NOTE 7)
$0 \text{ MHz} \leq \Delta f < 1.4 \text{ MHz}$	$0.05 \text{ MHz} \leq f_{\text{offset}} < 1.45 \text{ MHz}$	$8\text{dBm} - \frac{10}{1.4} \cdot \left( \frac{f_{\text{offset}}}{\text{MHz}} - 0.05 \right) \text{dB}$	100 kHz
$1.4 \text{ MHz} \leq \Delta f < 2.8 \text{ MHz}$	$1.45 \text{ MHz} \leq f_{\text{offset}} < 2.85 \text{ MHz}$	-2 dBm	100 kHz
$2.8 \text{ MHz} \leq \Delta f \leq \Delta f_{\text{max}}$	$2.85 \text{ MHz} \leq f_{\text{offset}} < f_{\text{offset}_{\text{max}}}$	-4 dBm	100 kHz
NOTE 1: For a RIB supporting <i>non-contiguous spectrum</i> operation within any operating band, the <i>minimum requirement</i> within <i>sub-block gaps</i> is calculated as a cumulative sum of contributions from adjacent sub blocks on each side of the <i>sub-block gap</i> . Exception is $\Delta f \geq 10\text{MHz}$ from both adjacent sub blocks on each side of the <i>sub-block gap</i> , where the <i>minimum requirement</i> within <i>sub-block gaps</i> shall be -13dBm/100kHz.			
NOTE 2: For a <i>multi-band RIB</i> with <i>Inter RF Bandwidth gap</i> $< 2 \times \Delta f_{\text{OBUE}}$ the <i>minimum requirement</i> within the <i>Inter RF Bandwidth gaps</i> is calculated as a cumulative sum of contributions from adjacent sub-blocks or <i>Base Station RF Bandwidth</i> on each side of the <i>Inter RF Bandwidth gap</i> .			

**Table 9.7.5.4.2-2: Wide Area BS operating band unwanted emission limits for 3 MHz channel bandwidth (E-UTRA bands <1GHz) for Category A**

Frequency offset of measurement filter -3dB point, $\Delta f$	Frequency offset of measurement filter centre frequency, $f_{\text{offset}}$	Minimum requirement (NOTE 1, 2)	Measurement bandwidth (NOTE 7)
$0 \text{ MHz} \leq \Delta f < 3 \text{ MHz}$	$0.05 \text{ MHz} \leq f_{\text{offset}} < 3.05 \text{ MHz}$	$4\text{dBm} - \frac{10}{3} \cdot \left( \frac{f_{\text{offset}}}{\text{MHz}} - 0.05 \right) \text{dB}$	100 kHz
$3 \text{ MHz} \leq \Delta f < 6 \text{ MHz}$	$3.05 \text{ MHz} \leq f_{\text{offset}} < 6.05 \text{ MHz}$	-6 dBm	100 kHz
$6 \text{ MHz} \leq \Delta f \leq \Delta f_{\text{max}}$	$6.05 \text{ MHz} \leq f_{\text{offset}} < f_{\text{offset}_{\text{max}}}$	-4 dBm	100 kHz
NOTE 1: For a RIB supporting <i>non-contiguous spectrum</i> operation within any operating band, the <i>minimum requirement</i> within <i>sub-block gaps</i> is calculated as a cumulative sum of contributions from adjacent sub blocks on each side of the <i>sub-block gap</i> . Exception is $\Delta f \geq 10\text{MHz}$ from both adjacent sub blocks on each side of the <i>sub-block gap</i> , where the <i>minimum requirement</i> within <i>sub-block gaps</i> shall be -4dBm/100kHz.			
NOTE 2: For a <i>multi-band RIB</i> with <i>Inter RF Bandwidth gap</i> $< 2 \times \Delta f_{\text{OBUE}}$ the <i>minimum requirement</i> within the <i>Inter RF Bandwidth gaps</i> is calculated as a cumulative sum of contributions from adjacent sub-blocks or <i>Base Station RF Bandwidth</i> on each side of the <i>Inter RF Bandwidth gap</i> .			

**Table 9.7.5.4.2-3: Wide Area BS operating band unwanted emission limits for 5, 10, 15 and 20 MHz channel bandwidth (E-UTRA bands <1GHz) for Category A**

Frequency offset of measurement filter -3dB point, $\Delta f$	Frequency offset of measurement filter centre frequency, $f_{\text{offset}}$	Minimum requirement (NOTE 1, 2)	Measurement bandwidth (NOTE 7)
$0 \text{ MHz} \leq \Delta f < 5 \text{ MHz}$	$0.05 \text{ MHz} \leq f_{\text{offset}} < 5.05 \text{ MHz}$	$2\text{dBm} - \frac{7}{5} \cdot \left( \frac{f_{\text{offset}}}{\text{MHz}} - 0.05 \right) \text{dB}$	100 kHz
$5 \text{ MHz} \leq \Delta f < \min(10 \text{ MHz}, \Delta f_{\text{max}})$	$5.05 \text{ MHz} \leq f_{\text{offset}} < \min(10.05 \text{ MHz}, f_{\text{offset}_{\text{max}}})$	-5 dBm	100 kHz
$10 \text{ MHz} \leq \Delta f \leq \Delta f_{\text{max}}$	$10.05 \text{ MHz} \leq f_{\text{offset}} < f_{\text{offset}_{\text{max}}}$	-4 dBm (NOTE 9)	100 kHz
<p>NOTE 1: For a RIB supporting <i>non-contiguous spectrum</i> operation within any operating band, the <i>minimum requirement</i> within <i>sub-block gaps</i> is calculated as a cumulative sum of contributions from adjacent sub blocks on each side of the <i>sub-block gap</i>. Exception is <math>\Delta f \geq 10\text{MHz}</math> from both adjacent sub blocks on each side of the <i>sub-block gap</i>, where the <i>minimum requirement</i> within <i>sub-block gaps</i> shall be -4dBm/100kHz.</p> <p>NOTE 2: For a <i>multi-band RIB</i> with <i>Inter RF Bandwidth gap</i> <math>&lt; 2 \times \Delta f_{\text{OBUE}}</math> the <i>minimum requirement</i> within the <i>Inter RF Bandwidth gaps</i> is calculated as a cumulative sum of contributions from adjacent sub-blocks or <i>Base Station RF Bandwidth</i> on each side of the <i>Inter RF Bandwidth gap</i>.</p>			

For a E-UTRA RIB operating in Bands 1, 2, 3, 4, 7, 9, 10, 11, 21, 22, 23, 24, 25, 30, 32, 33, 34, 35, 36, 37, 38, 39, 40, 41, 42, 43, 45, 48, 50, 65, 66, 69, 70, 74, 75, emissions shall use the *minimum requirements* specified in tables 9.7.5.4.2-4 to 9.7.5.4.2-6:

**Table 9.7.5.4.2-4: Wide Area BS operating band unwanted emission limits for 1.4 MHz channel bandwidth (E-UTRA bands >1GHz) for Category A**

Frequency offset of measurement filter -3dB point, $\Delta f$	Frequency offset of measurement filter centre frequency, $f_{\text{offset}}$	Minimum requirement (NOTE 1, 2)	Measurement bandwidth (NOTE 7)
$0 \text{ MHz} \leq \Delta f < 1.4 \text{ MHz}$	$0.05 \text{ MHz} \leq f_{\text{offset}} < 1.45 \text{ MHz}$	$8\text{dBm} - \frac{10}{1.4} \cdot \left( \frac{f_{\text{offset}}}{\text{MHz}} - 0.05 \right) \text{dB}$	100 kHz
$1.4 \text{ MHz} \leq \Delta f < 2.8 \text{ MHz}$	$1.45 \text{ MHz} \leq f_{\text{offset}} < 2.85 \text{ MHz}$	-2 dBm	100 kHz
$2.8 \text{ MHz} \leq \Delta f \leq \Delta f_{\text{max}}$	$3.3 \text{ MHz} \leq f_{\text{offset}} < f_{\text{offset}_{\text{max}}}$	-4 dBm	1MHz
<p>NOTE 1: For a RIB supporting <i>non-contiguous spectrum</i> operation within any operating band, the <i>minimum requirement</i> within <i>sub-block gaps</i> is calculated as a cumulative sum of contributions from adjacent sub blocks on each side of the <i>sub-block gap</i>, where the contribution from the far-end sub-block shall be scaled according to the measurement bandwidth of the near-end sub-block. Exception is <math>\Delta f \geq 10\text{MHz}</math> from both adjacent sub blocks on each side of the <i>sub-block gap</i>, where the <i>minimum requirement</i> within <i>sub-block gaps</i> shall be -4dBm/1MHz.</p> <p>NOTE 2: For a <i>multi-band RIB</i> with <i>Inter RF Bandwidth gap</i> <math>&lt; 2 \times \Delta f_{\text{OBUE}}</math> the <i>minimum requirement</i> within the <i>Inter RF Bandwidth gaps</i> is calculated as a cumulative sum of contributions from adjacent sub-blocks or <i>Base Station RF Bandwidth</i> on each side of the <i>Inter RF Bandwidth gap</i>, where the contribution from the far-end sub-block or <i>RF Bandwidth</i> shall be scaled according to the measurement bandwidth of the near-end sub-block or <i>Base Station RF Bandwidth</i>.</p>			

**Table 9.7.5.4.2-5: Wide Area BS operating band unwanted emission limits for 3 MHz channel bandwidth (E-UTRA bands >1GHz) for Category A**

Frequency offset of measurement filter -3dB point, $\Delta f$	Frequency offset of measurement filter centre frequency, $f_{\text{offset}}$	Minimum requirement (NOTE 1, 2)	Measurement bandwidth (NOTE 7)
$0 \text{ MHz} \leq \Delta f < 3 \text{ MHz}$	$0.05 \text{ MHz} \leq f_{\text{offset}} < 3.05 \text{ MHz}$	$4\text{dBm} - \frac{10}{3} \cdot \left( \frac{f_{\text{offset}}}{\text{MHz}} - 0.05 \right) \text{dB}$	100 kHz
$3 \text{ MHz} \leq \Delta f < 6 \text{ MHz}$	$3.05 \text{ MHz} \leq f_{\text{offset}} < 6.05 \text{ MHz}$	-6 dBm	100 kHz
$6 \text{ MHz} \leq \Delta f \leq \Delta f_{\text{max}}$	$6.5 \text{ MHz} \leq f_{\text{offset}} < f_{\text{offset,max}}$	-4 dBm	1MHz
<p>NOTE 1: For a RIB supporting <i>non-contiguous spectrum</i> operation within any operating band, the <i>minimum requirement</i> within <i>sub-block gaps</i> is calculated as a cumulative sum of contributions from adjacent sub blocks on each side of the <i>sub-block gap</i>, where the contribution from the far-end sub-block shall be scaled according to the measurement bandwidth of the near-end sub-block. Exception is <math>\Delta f \geq 10\text{MHz}</math> from both adjacent sub blocks on each side of the <i>sub-block gap</i>, where the <i>minimum requirement</i> within <i>sub-block gaps</i> shall be -4dBm/1MHz.</p> <p>NOTE 2: For a <i>multi-band RIB</i> with <i>Inter RF Bandwidth gap</i> <math>&lt; 2 \times \Delta f_{\text{OBUE}}</math> the <i>minimum requirement</i> within the <i>Inter RF Bandwidth gaps</i> is calculated as a cumulative sum of contributions from adjacent sub-blocks or <i>Base Station RF Bandwidth</i> on each side of the <i>Inter RF Bandwidth gap</i>, where the contribution from the far-end sub-block or <i>Base Station RF Bandwidth</i> shall be scaled according to the measurement bandwidth of the near-end sub-block or <i>Base Station RF Bandwidth</i>.</p>			

**Table 9.7.5.4.2-6: Wide Area BS operating band unwanted emission limits for 5, 10, 15 and 20 MHz channel bandwidth (E-UTRA bands >1GHz) for Category A**

Frequency offset of measurement filter -3dB point, $\Delta f$	Frequency offset of measurement filter centre frequency, $f_{\text{offset}}$	Minimum requirement (NOTE 1, 2)	Measurement bandwidth (NOTE 7)
$0 \text{ MHz} \leq \Delta f < 5 \text{ MHz}$	$0.05 \text{ MHz} \leq f_{\text{offset}} < 5.05 \text{ MHz}$	$2\text{dBm} - \frac{7}{5} \cdot \left( \frac{f_{\text{offset}}}{\text{MHz}} - 0.05 \right) \text{dB}$	100 kHz
$5 \text{ MHz} \leq \Delta f < \min(10 \text{ MHz}, \Delta f_{\text{max}})$	$5.05 \text{ MHz} \leq f_{\text{offset}} < \min(10.05 \text{ MHz}, f_{\text{offset,max}})$	-5 dBm	100 kHz
$10 \text{ MHz} \leq \Delta f \leq \Delta f_{\text{max}}$	$10.5 \text{ MHz} \leq f_{\text{offset}} < f_{\text{offset,max}}$	-4 dBm (NOTE 7)	1MHz
<p>NOTE 1: For a RIB supporting <i>non-contiguous spectrum</i> operation within any operating band, the <i>minimum requirement</i> within <i>sub-block gaps</i> is calculated as a cumulative sum of contributions from adjacent sub blocks on each side of the <i>sub-block gap</i>, where the contribution from the far-end sub-block shall be scaled according to the measurement bandwidth of the near-end sub-block. Exception is <math>\Delta f \geq 10\text{MHz}</math> from both adjacent sub blocks on each side of the <i>sub-block gap</i>, where the <i>minimum requirement</i> within <i>sub-block gaps</i> shall be -4dBm/1MHz.</p> <p>NOTE 2: For a <i>multi-band RIB</i> with <i>Inter RF Bandwidth gap</i> <math>&lt; 2 \times \Delta f_{\text{OBUE}}</math> the <i>minimum requirement</i> within the <i>Inter RF Bandwidth gaps</i> is calculated as a cumulative sum of contributions from adjacent sub-blocks or <i>Base Station RF Bandwidth</i> on each side of the <i>Inter RF Bandwidth gap</i>, where the contribution from the far-end sub-block or <i>Base Station RF Bandwidth</i> shall be scaled according to the measurement bandwidth of the near-end sub-block or <i>Base Station RF Bandwidth</i>.</p>			

### 9.7.5.4.3 Minimum requirements for Wide Area BS (Category B)

#### 9.7.5.4.3.1 General

For Category B Operating band unwanted emissions, there are two options for the limits that may be applied regionally. Either the limits in subclause 9.7.5.4.3.2 or subclause 9.7.5.4.3 shall be applied.

#### 9.7.5.4.3.2 Category B requirements (Option 1)

For a E-UTRA RIB operating in Bands 5, 8, 12, 13, 14, 17, 20, 26, 27, 28, 29, 31, 44, 67, 68, 71, 72, 73, 85, 87, 88 emissions shall use the minimum requirements specified in tables 6.6.5.4.3.2-1 to 6.6.5.4.3.2-3:

**Table 9.7.5.4.3.2-1: Wide Area BS operating band unwanted emission limits for 1.4 MHz channel bandwidth (E-UTRA bands <1GHz) for Category B**

Frequency offset of measurement filter -3dB point, $\Delta f$	Frequency offset of measurement filter centre frequency, $f_{\text{offset}}$	Minimum requirement (NOTE 1, 2)	Measurement bandwidth (NOTE 7)
$0 \text{ MHz} \leq \Delta f < 1.4 \text{ MHz}$	$0.05 \text{ MHz} \leq f_{\text{offset}} < 1.45 \text{ MHz}$	$8\text{dBm} - \frac{10}{1.4} \cdot \left( \frac{f_{\text{offset}}}{\text{MHz}} - 0.05 \right) \text{dB}$	100 kHz
$1.4 \text{ MHz} \leq \Delta f < 2.8 \text{ MHz}$	$1.45 \text{ MHz} \leq f_{\text{offset}} < 2.85 \text{ MHz}$	-2 dBm	100 kHz
$2.8 \text{ MHz} \leq \Delta f \leq \Delta f_{\text{max}}$	$2.85 \text{ MHz} \leq f_{\text{offset}} < f_{\text{offset}_{\text{max}}}$	-7 dBm	100 kHz
NOTE 1: For a RIB supporting <i>non-contiguous spectrum</i> operation within any operating band, the <i>minimum requirement</i> within <i>sub-block gaps</i> is calculated as a cumulative sum of contributions from adjacent sub blocks on each side of the <i>sub-block gap</i> . Exception is $\Delta f \geq 10\text{MHz}$ from both adjacent sub blocks on each side of the <i>sub-block gap</i> , where the <i>minimum requirement</i> within <i>sub-block gaps</i> shall be -7dBm/100kHz.			
NOTE 2: For a <i>multi-band RIB</i> with <i>Inter RF Bandwidth gap</i> $< 2 \times \Delta f_{\text{OBUE}}$ the <i>minimum requirement</i> within the <i>Inter RF Bandwidth gaps</i> is calculated as a cumulative sum of contributions from adjacent sub-blocks or <i>Base Station RF Bandwidth</i> on each side of the <i>Inter RF Bandwidth gap</i> .			

**Table 9.7.5.4.3.2-2: Wide Area BS operating band unwanted emission limits for 3 MHz channel bandwidth (E-UTRA bands <1GHz) for Category B**

Frequency offset of measurement filter -3dB point, $\Delta f$	Frequency offset of measurement filter centre frequency, $f_{\text{offset}}$	Minimum requirement (NOTE 1, 2)	Measurement bandwidth (NOTE 7)
$0 \text{ MHz} \leq \Delta f < 3 \text{ MHz}$	$0.05 \text{ MHz} \leq f_{\text{offset}} < 3.05 \text{ MHz}$	$4\text{dBm} - \frac{10}{3} \cdot \left( \frac{f_{\text{offset}}}{\text{MHz}} - 0.05 \right) \text{dB}$	100 kHz
$3 \text{ MHz} \leq \Delta f < 6 \text{ MHz}$	$3.05 \text{ MHz} \leq f_{\text{offset}} < 6.05 \text{ MHz}$	-6 dBm	100 kHz
$6 \text{ MHz} \leq \Delta f \leq \Delta f_{\text{max}}$	$6.05 \text{ MHz} \leq f_{\text{offset}} < f_{\text{offset}_{\text{max}}}$	-7 dBm	100 kHz
NOTE 1: For a RIB supporting <i>non-contiguous spectrum</i> operation within any operating band, the <i>minimum requirement</i> within <i>sub-block gaps</i> is calculated as a cumulative sum of contributions from adjacent sub blocks on each side of the <i>sub-block gap</i> . Exception is $\Delta f \geq 10\text{MHz}$ from both adjacent sub blocks on each side of the <i>sub-block gap</i> , where the <i>minimum requirement</i> within <i>sub-block gaps</i> shall be -7dBm/100kHz.			
NOTE 2: For a <i>multi-band RIB</i> with <i>Inter RF Bandwidth gap</i> $< 2 \times \Delta f_{\text{OBUE}}$ the <i>minimum requirement</i> within the <i>Inter RF Bandwidth gaps</i> is calculated as a cumulative sum of contributions from adjacent sub-blocks or <i>Base Station RF Bandwidth</i> on each side of the <i>Inter RF Bandwidth gap</i> .			

**Table 9.7.5.4.3.2-3: Wide Area BS operating band unwanted emission limits for 5, 10, 15 and 20 MHz channel bandwidth (E-UTRA bands <1GHz) for Category B**

Frequency offset of measurement filter -3dB point, $\Delta f$	Frequency offset of measurement filter centre frequency, $f_{\text{offset}}$	Minimum requirement (NOTE 1, 2)	Measurement bandwidth (NOTE 7)
$0 \text{ MHz} \leq \Delta f < 5 \text{ MHz}$	$0.05 \text{ MHz} \leq f_{\text{offset}} < 5.05 \text{ MHz}$	$2\text{dBm} - \frac{7}{5} \cdot \left( \frac{f_{\text{offset}}}{\text{MHz}} - 0.05 \right) \text{dB}$	100 kHz
$5 \text{ MHz} \leq \Delta f < \min(10 \text{ MHz}, \Delta f_{\text{max}})$	$5.05 \text{ MHz} \leq f_{\text{offset}} < \min(10.05 \text{ MHz}, f_{\text{offset}_{\text{max}}})$	-5 dBm	100 kHz
$10 \text{ MHz} \leq \Delta f \leq \Delta f_{\text{max}}$	$10.05 \text{ MHz} \leq f_{\text{offset}} < f_{\text{offset}_{\text{max}}}$	-7 dBm (NOTE 7)	100 kHz
NOTE 1: For a RIB supporting <i>non-contiguous spectrum</i> operation within any operating band, the <i>minimum requirement</i> within <i>sub-block gaps</i> is calculated as a cumulative sum of contributions from adjacent sub blocks on each side of the <i>sub-block gap</i> . Exception is $\Delta f \geq 10\text{MHz}$ from both adjacent sub blocks on each side of the <i>sub-block gap</i> , where the <i>minimum requirement</i> within <i>sub-block gaps</i> shall be -7dBm/100kHz.			
NOTE 2: For a <i>multi-band RIB</i> with <i>Inter RF Bandwidth gap</i> $< 2 \times \Delta f_{\text{OBUE}}$ the <i>minimum requirement</i> within the <i>Inter RF Bandwidth gaps</i> is calculated as a cumulative sum of contributions from adjacent sub-blocks or <i>Base Station RF Bandwidth</i> on each side of the <i>Inter RF Bandwidth gap</i> .			

For a E-UTRA RIB operating in Bands 1, 2, 3, 4, 7, 10, 22, 25, 30, 33, 34, 35, 36, 37, 38, 39, 40, 41, 42, 43, 45, 48, 50, 65, 66, 69, 70, 75, emissions shall use the *minimum requirements* specified in tables 9.7.5.4.3.2-4 to 9.7.5.4.3.2-6:

**Table 9.7.5.4.3.2-4: Wide Area BS operating band unwanted emission limits for 1.4 MHz channel bandwidth (E-UTRA bands >1GHz) for Category B**

Frequency offset of measurement filter -3dB point, $\Delta f$	Frequency offset of measurement filter centre frequency, $f_{\text{offset}}$	Minimum requirement (NOTE 1, 2)	Measurement bandwidth (NOTE 7)
$0 \text{ MHz} \leq \Delta f < 1.4 \text{ MHz}$	$0.05 \text{ MHz} \leq f_{\text{offset}} < 1.45 \text{ MHz}$	$8\text{dBm} - \frac{10}{1.4} \cdot \left( \frac{f_{\text{offset}}}{\text{MHz}} - 0.05 \right) \text{dB}$	100 kHz
$1.4 \text{ MHz} \leq \Delta f < 2.8 \text{ MHz}$	$1.45 \text{ MHz} \leq f_{\text{offset}} < 2.85 \text{ MHz}$	-2 dBm	100 kHz
$2.8 \text{ MHz} \leq \Delta f \leq \Delta f_{\text{max}}$	$3.3 \text{ MHz} \leq f_{\text{offset}} < f_{\text{offset}_{\text{max}}}$	-6 dBm	1MHz
<p>NOTE 1: For a RIB supporting <i>non-contiguous spectrum</i> operation within any operating band, the <i>minimum requirement</i> within <i>sub-block gaps</i> is calculated as a cumulative sum of contributions from adjacent sub blocks on each side of the <i>sub-block gap</i>, where the contribution from the far-end sub-block shall be scaled according to the measurement bandwidth of the near-end sub-block. Exception is <math>\Delta f \geq 10\text{MHz}</math> from both adjacent sub blocks on each side of the <i>sub-block gap</i>, where the <i>minimum requirement</i> within <i>sub-block gaps</i> shall be -6dBm/1MHz.</p> <p>NOTE 2: For a <i>multi-band RIB</i> with <i>Inter RF Bandwidth gap</i> <math>&lt; 2 \times \Delta f_{\text{OBUE}}</math> the <i>minimum requirement</i> within the <i>Inter RF Bandwidth gaps</i> is calculated as a cumulative sum of contributions from adjacent sub-blocks or <i>Base Station RF Bandwidth</i> on each side of the <i>Inter RF Bandwidth gap</i>, where the contribution from the far-end sub-block or <i>Base Station RF Bandwidth</i> shall be scaled according to the measurement bandwidth of the near-end sub-block or <i>Base Station RF Bandwidth</i>.</p>			

**Table 9.7.5.4.3.2-5: Wide Area BS operating band unwanted emission limits for 3 MHz channel bandwidth (E-UTRA bands >1GHz) for Category B**

Frequency offset of measurement filter -3dB point, $\Delta f$	Frequency offset of measurement filter centre frequency, $f_{\text{offset}}$	Minimum requirement (NOTE 1, 2)	Measurement bandwidth (NOTE 7)
$0 \text{ MHz} \leq \Delta f < 3 \text{ MHz}$	$0.05 \text{ MHz} \leq f_{\text{offset}} < 3.05 \text{ MHz}$	$4\text{dBm} - \frac{10}{3} \cdot \left( \frac{f_{\text{offset}}}{\text{MHz}} - 0.05 \right) \text{dB}$	100 kHz
$3 \text{ MHz} \leq \Delta f < 6 \text{ MHz}$	$3.05 \text{ MHz} \leq f_{\text{offset}} < 6.05 \text{ MHz}$	-6 dBm	100 kHz
$6 \text{ MHz} \leq \Delta f \leq \Delta f_{\text{max}}$	$6.5 \text{ MHz} \leq f_{\text{offset}} < f_{\text{offset}_{\text{max}}}$	-6 dBm	1MHz
<p>NOTE 1: For a RIB supporting <i>non-contiguous spectrum</i> operation within any operating band, the <i>minimum requirement</i> within <i>sub-block gaps</i> is calculated as a cumulative sum of contributions from adjacent sub blocks on each side of the <i>sub-block gap</i>, where the contribution from the far-end sub-block shall be scaled according to the measurement bandwidth of the near-end sub-block. Exception is <math>\Delta f \geq 10\text{MHz}</math> from both adjacent sub blocks on each side of the <i>sub-block gap</i>, where the <i>minimum requirement</i> within <i>sub-block gaps</i> shall be -6dBm/1MHz.</p> <p>NOTE 2: For a <i>multi-band RIB</i> with <i>Inter RF Bandwidth gap</i> <math>&lt; 2 \times \Delta f_{\text{OBUE}}</math> the <i>minimum requirement</i> within the <i>Inter RF Bandwidth gaps</i> is calculated as a cumulative sum of contributions from adjacent sub-blocks or <i>Base Station RF Bandwidth</i> on each side of the <i>Inter RF Bandwidth gap</i>, where the contribution from the far-end sub-block or <i>Base Station RF Bandwidth</i> shall be scaled according to the measurement bandwidth of the near-end sub-block or <i>Base Station RF Bandwidth</i>.</p>			

**Table 9.7.5.4.3.2-6: Wide Area BS operating band unwanted emission limits for 5, 10, 15 and 20 MHz channel bandwidth (E-UTRA bands >1GHz) for Category B**

Frequency offset of measurement filter -3dB point, $\Delta f$	Frequency offset of measurement filter centre frequency, $f_{\text{offset}}$	Minimum requirement (NOTE 1, 2)	Measurement bandwidth (NOTE 7)
$0 \text{ MHz} \leq \Delta f < 5 \text{ MHz}$	$0.05 \text{ MHz} \leq f_{\text{offset}} < 5.05 \text{ MHz}$	$2\text{dBm} - \frac{7}{5} \cdot \left( \frac{f_{\text{offset}}}{\text{MHz}} - 0.05 \right) \text{dB}$	100 kHz
$5 \text{ MHz} \leq \Delta f < \min(10 \text{ MHz}, \Delta f_{\text{max}})$	$5.05 \text{ MHz} \leq f_{\text{offset}} < \min(10.05 \text{ MHz}, f_{\text{offset}_{\text{max}}})$	-5 dBm	100 kHz
$10 \text{ MHz} \leq \Delta f \leq \Delta f_{\text{max}}$	$10.5 \text{ MHz} \leq f_{\text{offset}} < f_{\text{offset}_{\text{max}}}$	-6 dBm (NOTE 7)	1MHz
NOTE 1: For a RIB supporting <i>non-contiguous spectrum</i> operation within any operating band, the <i>minimum requirement</i> within <i>sub-block gaps</i> is calculated as a cumulative sum of contributions from adjacent sub blocks on each side of the <i>sub-block gap</i> , where the contribution from the far-end sub-block shall be scaled according to the measurement bandwidth of the near-end sub-block. Exception is $\Delta f \geq 10\text{MHz}$ from both adjacent sub blocks on each side of the <i>sub-block gap</i> , where the <i>minimum requirement</i> within <i>sub-block gaps</i> shall be -6dBm/1MHz.			
NOTE 2: For a <i>multi-band RIB</i> with <i>Inter RF Bandwidth gap</i> $< 2 \times \Delta f_{\text{OBUE}}$ the <i>minimum requirement</i> within the <i>Inter RF Bandwidth gaps</i> is calculated as a cumulative sum of contributions from adjacent sub-blocks or <i>Base Station RF Bandwidth</i> on each side of the <i>Inter RF Bandwidth gap</i> , where the contribution from the far-end sub-block or <i>Base Station RF Bandwidth</i> shall be scaled according to the measurement bandwidth of the near-end sub-block or <i>Base Station RF Bandwidth</i> .			

## 9.7.5.4.3.3 Category B requirements (Option 2)

The limits in this subclause are intended for Europe and may be applied regionally for a RIB operating in band 1, 3, 8, 32, 33, 34 or 65.

For a RIB operating in band 1, 3, 8, 32, 33, 34 or 65, emissions shall use the minimum requirements specified in table 9.7.5.4.3.3-1 below for 5, 10, 15 and 20 MHz *channel bandwidth*:

**Table 9.7.5.4.3.3-1: Regional Wide Area BS operating band unwanted emission limits in band 1, 3, 8, 32, 33, 34 or 65 for 5, 10, 15 and 20 MHz channel bandwidth for Category B**

Frequency offset of measurement filter -3dB point, $\Delta f$	Frequency offset of measurement filter centre frequency, $f_{\text{offset}}$	Minimum requirement (NOTE 1, 2)	Measurement bandwidth (NOTE 7)
$0 \text{ MHz} \leq \Delta f < 0.2 \text{ MHz}$	$0.015\text{MHz} \leq f_{\text{offset}} < 0.215\text{MHz}$	-5 dBm	30 kHz
$0.2 \text{ MHz} \leq \Delta f < 1 \text{ MHz}$	$0.215\text{MHz} \leq f_{\text{offset}} < 1.015\text{MHz}$	$-5\text{dBm} - 15 \cdot \left( \frac{f_{\text{offset}}}{\text{MHz}} - 0.215 \right) \text{dB}$	30 kHz
(NOTE 8)	$1.015\text{MHz} \leq f_{\text{offset}} < 1.5 \text{ MHz}$	-17 dBm	30 kHz
$1 \text{ MHz} \leq \Delta f \leq \min(10 \text{ MHz}, \Delta f_{\text{max}})$	$1.5 \text{ MHz} \leq f_{\text{offset}} < \min(10.5 \text{ MHz}, f_{\text{offset}_{\text{max}}})$	-4 dBm	1 MHz
$10 \text{ MHz} \leq \Delta f \leq \Delta f_{\text{max}}$	$10.5 \text{ MHz} \leq f_{\text{offset}} < f_{\text{offset}_{\text{max}}}$	-6 dBm (NOTE 7)	1 MHz
NOTE 1: For a RIB supporting <i>non-contiguous spectrum</i> operation within any operating band, the <i>minimum requirement</i> within <i>sub-block gaps</i> is calculated as a cumulative sum of contributions from adjacent sub blocks on each side of the <i>sub-block gap</i> , where the contribution from the far-end sub-block shall be scaled according to the measurement bandwidth of the near-end sub-block. Exception is $\Delta f \geq 10\text{MHz}$ from both adjacent sub blocks on each side of the <i>sub-block gap</i> , where the <i>minimum requirement</i> within <i>sub-block gaps</i> shall be -6dBm/1MHz.			
NOTE 2: For a <i>multi-band RIB</i> with <i>Inter RF Bandwidth gap</i> $< 2 \times \Delta f_{\text{OBUE}}$ the <i>minimum requirement</i> within the <i>Inter RF Bandwidth gaps</i> is calculated as a cumulative sum of contributions from adjacent sub-blocks or <i>Base Station RF Bandwidth</i> on each side of the <i>Inter RF Bandwidth gap</i> , where the contribution from the far-end sub-block or <i>Base Station RF Bandwidth</i> shall be scaled according to the measurement bandwidth of the near-end sub-block or <i>Base Station RF Bandwidth</i> .			

For a RIB operating in band 3 or 8, emissions shall use the *minimum requirements* specified in table 9.7.5.4.3.3-2 below for 3 MHz *channel bandwidth*:

**Table 9.7.5.4.3.3-2: Regional Wide Area BS operating band unwanted emission limits in band 3 or 8 for 3 MHz channel bandwidth for Category B**

Frequency offset of measurement filter -3dB point, $\Delta f$	Frequency offset of measurement filter centre frequency, $f_{\text{offset}}$	Minimum requirement (NOTE 1, 2)	Measurement bandwidth (NOTE 7)
$0 \text{ MHz} \leq \Delta f < 0.05 \text{ MHz}$	$0.015 \text{ MHz} \leq f_{\text{offset}} < 0.065 \text{ MHz}$	$14 \text{ dBm} - 60 \left( \frac{f_{\text{offset}}}{\text{MHz}} - 0.015 \right) \text{ dB}$	30 kHz
$0.05 \text{ MHz} \leq \Delta f < 0.15 \text{ MHz}$	$0.065 \text{ MHz} \leq f_{\text{offset}} < 0.165 \text{ MHz}$	$14 \text{ dBm} - 160 \left( \frac{f_{\text{offset}}}{\text{MHz}} - 0.065 \right) \text{ dB}$	30 kHz
$0.15 \text{ MHz} \leq \Delta f < 0.2 \text{ MHz}$	$0.165 \text{ MHz} \leq f_{\text{offset}} < 0.215 \text{ MHz}$	-5 dBm	30 kHz
$0.2 \text{ MHz} \leq \Delta f < 1 \text{ MHz}$	$0.215 \text{ MHz} \leq f_{\text{offset}} < 1.015 \text{ MHz}$	$-5 \text{ dBm} - 15 \cdot \left( \frac{f_{\text{offset}}}{\text{MHz}} - 0.215 \right) \text{ dB}$	30 kHz
(NOTE 8)	$1.015 \text{ MHz} \leq f_{\text{offset}} < 1.5 \text{ MHz}$	-17 dBm	30 kHz
$1 \text{ MHz} \leq \Delta f \leq 6 \text{ MHz}$	$1.5 \text{ MHz} \leq f_{\text{offset}} < 6.5 \text{ MHz}$	-4 dBm	1 MHz
$6 \text{ MHz} \leq \Delta f \leq \Delta f_{\text{max}}$	$6.5 \text{ MHz} \leq f_{\text{offset}} < f_{\text{offset}_{\text{max}}}$	-6 dBm	1 MHz
<p>NOTE 1: For a RIB supporting <i>non-contiguous spectrum</i> operation within any operating band, the <i>minimum requirement</i> within <i>sub-block gaps</i> is calculated as a cumulative sum of contributions from adjacent sub blocks on each side of the <i>sub-block gap</i>, where the contribution from the far-end sub-block shall be scaled according to the measurement bandwidth of the near-end sub-block. Exception is <math>\Delta f \geq 10 \text{ MHz}</math> from both adjacent sub blocks on each side of the <i>sub-block gap</i>, where the <i>minimum requirement</i> within <i>sub-block gaps</i> shall be -6dBm/1MHz.</p> <p>NOTE 2: For a <i>multi-band RIB</i> with <i>Inter RF Bandwidth gap</i> <math>&lt; 2 \times \Delta f_{\text{OBUE}}</math> the <i>minimum requirement</i> within the <i>Inter RF Bandwidth gaps</i> is calculated as a cumulative sum of contributions from adjacent sub-blocks or <i>Base Station RF Bandwidth</i> on each side of the <i>Inter RF Bandwidth gap</i>, where the contribution from the far-end sub-block or <i>Base Station RF Bandwidth</i> shall be scaled according to the measurement bandwidth of the near-end sub-block or <i>Base Station RF Bandwidth</i>.</p>			

For a RIB operating in band 3 or 8, emissions shall not use the minimum requirements specified in table 9.7.5.4.3.3-3 below for 1.4 MHz channel bandwidth:

**Table 9.7.5.4.3-3: Regional Wide Area BS operating band unwanted emission limits in band 3 or 8 for 1.4 MHz channel bandwidth for Category B**

Frequency offset of measurement filter -3dB point, $\Delta f$	Frequency offset of measurement filter centre frequency, $f_{\text{offset}}$	Minimum requirement (NOTE 1, 2)	Measurement bandwidth (NOTE 7)
$0 \text{ MHz} \leq \Delta f < 0.05 \text{ MHz}$	$0.015 \text{ MHz} \leq f_{\text{offset}} < 0.065 \text{ MHz}$	$14 \text{ dBm} - 60 \left( \frac{f_{\text{offset}}}{\text{MHz}} - 0.015 \right) \text{ dB}$	30 kHz
$0.05 \text{ MHz} \leq \Delta f < 0.15 \text{ MHz}$	$0.065 \text{ MHz} \leq f_{\text{offset}} < 0.165 \text{ MHz}$	$14 \text{ dBm} - 160 \left( \frac{f_{\text{offset}}}{\text{MHz}} - 0.065 \right) \text{ dB}$	30 kHz
$0.15 \text{ MHz} \leq \Delta f < 0.2 \text{ MHz}$	$0.165 \text{ MHz} \leq f_{\text{offset}} < 0.215 \text{ MHz}$	-5 dBm	30 kHz
$0.2 \text{ MHz} \leq \Delta f < 1 \text{ MHz}$	$0.215 \text{ MHz} \leq f_{\text{offset}} < 1.015 \text{ MHz}$	$-5 \text{ dBm} - 15 \cdot \left( \frac{f_{\text{offset}}}{\text{MHz}} - 0.215 \right) \text{ dB}$	30 kHz
(NOTE 8)	$1.015 \text{ MHz} \leq f_{\text{offset}} < 1.5 \text{ MHz}$	-17 dBm	30 kHz
$1 \text{ MHz} \leq \Delta f \leq 2.8 \text{ MHz}$	$1.5 \text{ MHz} \leq f_{\text{offset}} < 3.3 \text{ MHz}$	-4 dBm	1 MHz
$2.8 \text{ MHz} \leq \Delta f \leq \Delta f_{\text{max}}$	$3.3 \text{ MHz} \leq f_{\text{offset}} < f_{\text{offset}_{\text{max}}}$	-6 dBm	1 MHz
<p>NOTE 1: For a RIB supporting <i>non-contiguous spectrum</i> operation within any operating band, the <i>minimum requirement</i> within <i>sub-block gaps</i> is calculated as a cumulative sum of contributions from adjacent sub blocks on each side of the <i>sub-block gap</i>, where the contribution from the far-end sub-block shall be scaled according to the measurement bandwidth of the near-end sub-block. Exception is <math>\Delta f \geq 10 \text{ MHz}</math> from both adjacent sub blocks on each side of the <i>sub-block gap</i>, where the minimum requirement within <i>sub-block gaps</i> shall be -6dBm/1MHz.</p> <p>NOTE 2: For a <i>multi-band RIB</i> with <i>Inter RF Bandwidth gap</i> <math>&lt; 2 \times \Delta f_{\text{OBUE}}</math> the minimum requirement within the <i>Inter RF Bandwidth gaps</i> is calculated as a cumulative sum of contributions from adjacent sub-blocks or <i>Base Station RF Bandwidth</i> on each side of the <i>Inter RF Bandwidth gap</i>, where the contribution from the far-end sub-block or <i>Base Station RF Bandwidth</i> shall be scaled according to the measurement bandwidth of the near-end sub-block or <i>Base Station RF Bandwidth</i>.</p>			

#### 9.7.5.4.4 Minimum requirements for Local Area BS (Category A and B)

For Local Area BS, *minimum requirements* are specified in tables 9.7.5.4.4-1 to 9.7.5.4.4-3.

**Table 9.7.5.4.4-1: Local Area BS operating band unwanted emission limits for 1.4 MHz channel bandwidth**

Frequency offset of measurement filter -3dB point, $\Delta f$	Frequency offset of measurement filter centre frequency, $f_{\text{offset}}$	Minimum requirement (NOTE 1, 2)	Measurement bandwidth (NOTE 7)
$0 \text{ MHz} \leq \Delta f < 1.4 \text{ MHz}$	$0.05 \text{ MHz} \leq f_{\text{offset}} < 1.45 \text{ MHz}$	$-12 \text{ dB} - \frac{10}{1.4} \left( \frac{f_{\text{offset}}}{\text{MHz}} - 0.05 \right) \text{ dB}$	100 kHz
$1.4 \text{ MHz} \leq \Delta f < 2.8 \text{ MHz}$	$1.45 \text{ MHz} \leq f_{\text{offset}} < 2.85 \text{ MHz}$	-22 dBm	100 kHz
$2.8 \text{ MHz} \leq \Delta f \leq \Delta f_{\text{max}}$	$2.85 \text{ MHz} \leq f_{\text{offset}} < f_{\text{offset}_{\text{max}}}$	-22 dBm	100 kHz
<p>NOTE 1: For a RIB supporting <i>non-contiguous spectrum</i> operation within any operating band the <i>minimum requirement</i> within <i>sub-block gaps</i> is calculated as a cumulative sum of contributions from adjacent sub blocks on each side of the <i>sub-block gap</i>. Exception is <math>\Delta f \geq 10 \text{ MHz}</math> from both adjacent sub blocks on each side of the <i>sub-block gap</i>, where the <i>minimum requirement</i> within <i>sub-block gaps</i> shall be -22dBm/100kHz.</p> <p>NOTE 2: For a <i>multi-band RIB</i> with <i>Inter RF Bandwidth gap</i> <math>&lt; 2 \times \Delta f_{\text{OBUE}}</math> the <i>minimum requirement</i> within the <i>Inter RF Bandwidth gaps</i> is calculated as a cumulative sum of contributions from adjacent sub-blocks or <i>Base Station RF Bandwidth</i> on each side of the <i>Inter RF Bandwidth gap</i>.</p>			

**Table 9.7.5.4.4-2: Local Area BS operating band unwanted emission limits for 3 MHz *channel bandwidth***

Frequency offset of measurement filter -3dB point, $\Delta f$	Frequency offset of measurement filter centre frequency, $f_{\text{offset}}$	Minimum requirement (NOTE 1, 2)	Measurement bandwidth (NOTE 7)
$0 \text{ MHz} \leq \Delta f < 3 \text{ MHz}$	$0.05 \text{ MHz} \leq f_{\text{offset}} < 3.05 \text{ MHz}$	$-16 \text{ dB} - \frac{10}{3} \left( \frac{f_{\text{offset}}}{\text{MHz}} - 0.05 \right) \text{ dB}$	100 kHz
$3 \text{ MHz} \leq \Delta f < 6 \text{ MHz}$	$3.05 \text{ MHz} \leq f_{\text{offset}} < 6.05 \text{ MHz}$	-26 dBm	100 kHz
$6 \text{ MHz} \leq \Delta f \leq \Delta f_{\text{max}}$	$6.05 \text{ MHz} \leq f_{\text{offset}} < f_{\text{offset}_{\text{max}}}$	-26 dBm	100 kHz
NOTE 1: For a RIB supporting <i>non-contiguous spectrum</i> operation within any operating band the <i>minimum requirement</i> within <i>sub-block gaps</i> is calculated as a cumulative sum of contributions from adjacent sub blocks on each side of the <i>sub-block gap</i> . Exception is $\Delta f \geq 10 \text{ MHz}$ from both adjacent sub blocks on each side of the <i>sub-block gap</i> , where the <i>minimum requirement</i> within <i>sub-block gaps</i> shall be -26dBm/100kHz.			
NOTE 2: For a <i>multi-band RIB</i> with <i>Inter RF Bandwidth gap</i> $< 2 \times \Delta f_{\text{OBUE}}$ the <i>minimum requirement</i> within the <i>Inter RF Bandwidth gaps</i> is calculated as a cumulative sum of contributions from adjacent sub-blocks or <i>Base Station RF Bandwidth</i> on each side of the <i>Inter RF Bandwidth gap</i> .			

**Table 9.7.5.4.4-3: Local Area BS operating band unwanted emission limits for 5, 10, 15 and 20 MHz *channel bandwidth***

Frequency offset of measurement filter -3dB point, $\Delta f$	Frequency offset of measurement filter centre frequency, $f_{\text{offset}}$	Minimum requirement (NOTE 1, 2)	Measurement bandwidth (NOTE 7)
$0 \text{ MHz} \leq \Delta f < 5 \text{ MHz}$	$0.05 \text{ MHz} \leq f_{\text{offset}} < 5.05 \text{ MHz}$	$-24 \text{ dB} - \frac{7}{5} \left( \frac{f_{\text{offset}}}{\text{MHz}} - 0.05 \right) \text{ dB}$	100 kHz
$5 \text{ MHz} \leq \Delta f < \min(10 \text{ MHz}, \Delta f_{\text{max}})$	$5.05 \text{ MHz} \leq f_{\text{offset}} < \min(10.05 \text{ MHz}, f_{\text{offset}_{\text{max}}})$	-28 dBm	100 kHz
$10 \text{ MHz} \leq \Delta f \leq \Delta f_{\text{max}}$	$10.05 \text{ MHz} \leq f_{\text{offset}} < f_{\text{offset}_{\text{max}}}$	-28 dBm (NOTE 7)	100 kHz
NOTE 1: For a RIB supporting <i>non-contiguous spectrum</i> operation within any operating band the <i>minimum requirement</i> within <i>sub-block gaps</i> is calculated as a cumulative sum of contributions from adjacent sub blocks on each side of the <i>sub-block gap</i> . Exception is $\Delta f \geq 10 \text{ MHz}$ from both adjacent sub blocks on each side of the <i>sub-block gap</i> , where the <i>minimum requirement</i> within <i>sub-block gaps</i> shall be -28dBm/100kHz.			
NOTE 2: For a <i>multi-band RIB</i> with <i>Inter RF Bandwidth gap</i> $< 2 \times \Delta f_{\text{OBUE}}$ the <i>minimum requirement</i> within the <i>Inter RF Bandwidth gaps</i> is calculated as a cumulative sum of contributions from adjacent sub-blocks or <i>Base Station RF Bandwidth</i> on each side of the <i>Inter RF Bandwidth gap</i> .			

#### 9.7.5.4.5 Minimum requirements for Medium Range BS (Category A and B)

For Medium Range BS, *minimum requirements* are specified in tables 9.7.5.4.5-1 to 9.7.5.4.5-6.

**Table 9.7.5.4.5-1: Medium Range BS operating band unwanted emission limits for 1.4 MHz channel bandwidth,  $40 < P_{\text{rated,c,TRP}} \leq 47$  dBm**

Frequency offset of measurement filter -3dB point, $\Delta f$	Frequency offset of measurement filter centre frequency, $f_{\text{offset}}$	Minimum requirement (NOTE 1, 2)	Measurement bandwidth (NOTE 7)
$0 \text{ MHz} \leq \Delta f < 1.4 \text{ MHz}$	$0.05 \text{ MHz} \leq f_{\text{offset}} < 1.45 \text{ MHz}$	$P_{\text{rated,c,TRP}} - 45 \text{ dB} - (10/1.4) * (f_{\text{offset}} - 0.05) \text{ dB}$	100 kHz
$1.4 \text{ MHz} \leq \Delta f < 2.8 \text{ MHz}$	$1.45 \text{ MHz} \leq f_{\text{offset}} < 2.85 \text{ MHz}$	$P_{\text{rated,c,TRP}} - 55 \text{ dB}$	100 kHz
$2.8 \text{ MHz} \leq \Delta f \leq \Delta f_{\text{max}}$	$2.85 \text{ MHz} \leq f_{\text{offset}} < f_{\text{offset}_{\text{max}}}$	-16dBm	100 kHz

NOTE 1: For a RIB supporting *non-contiguous spectrum* operation within any operating band the *minimum requirement* within *sub-block gaps* is calculated as a cumulative sum of contributions from adjacent sub blocks on each side of the *sub-block gap*. Exception is  $\Delta f \geq 10 \text{ MHz}$  from both adjacent sub blocks on each side of the *sub-block gap*, where the *minimum requirement* within *sub-block gaps* shall be -16dBm/100kHz.

NOTE 2: For a *multi-band RIB* with *Inter RF Bandwidth gap*  $< 2 * \Delta f_{\text{OBUE}}$  the *minimum requirement* within the *Inter RF Bandwidth gaps* is calculated as a cumulative sum of contributions from adjacent sub-blocks or *Base Station RF Bandwidth* on each side of the *Inter RF Bandwidth gap*.

**Table 9.7.5.4.5-2: Medium Range BS operating band unwanted emission limits for 1.4 MHz channel bandwidth,  $P_{\text{rated,c,TRP}} \leq 40$  dBm**

Frequency offset of measurement filter -3dB point, $\Delta f$	Frequency offset of measurement filter centre frequency, $f_{\text{offset}}$	Minimum requirement (NOTE 1, 2)	Measurement bandwidth (NOTE 7)
$0 \text{ MHz} \leq \Delta f < 1.4 \text{ MHz}$	$0.05 \text{ MHz} \leq f_{\text{offset}} < 1.45 \text{ MHz}$	$-5 \text{ dBm} - \frac{10}{1.4} \left( \frac{f_{\text{offset}}}{\text{MHz}} - 0.05 \right) \text{ dB}$	100 kHz
$1.4 \text{ MHz} \leq \Delta f < 2.8 \text{ MHz}$	$1.45 \text{ MHz} \leq f_{\text{offset}} < 2.85 \text{ MHz}$	-15 dBm	100 kHz
$2.8 \text{ MHz} \leq \Delta f \leq \Delta f_{\text{max}}$	$2.85 \text{ MHz} \leq f_{\text{offset}} < f_{\text{offset}_{\text{max}}}$	-16dBm	100 kHz

NOTE 1: For a RIB supporting *non-contiguous spectrum* operation within any operating band the *minimum requirement* within *sub-block gaps* is calculated as a cumulative sum of contributions from adjacent sub blocks on each side of the *sub-block gap*. Exception is  $\Delta f \geq 10 \text{ MHz}$  from both adjacent sub blocks on each side of the *sub-block gap*, where the *minimum requirement* within *sub-block gaps* shall be -16dBm/100kHz.

NOTE 2: For a *multi-band RIB* with *Inter RF Bandwidth gap*  $< 2 * \Delta f_{\text{OBUE}}$  the *minimum requirement* within the *Inter RF Bandwidth gaps* is calculated as a cumulative sum of contributions from adjacent sub-blocks or *Base Station RF Bandwidth* on each side of the *Inter RF Bandwidth gap*.

**Table 9.7.5.4.5-3: Medium Range BS operating band unwanted emission limits for 3 MHz channel bandwidth,  $40 < P_{\text{rated,c,TRP}} \leq 47$  dBm**

Frequency offset of measurement filter -3dB point, $\Delta f$	Frequency offset of measurement filter centre frequency, $f_{\text{offset}}$	Minimum requirement (NOTE 1, 2)	Measurement bandwidth (NOTE 7)
$0 \text{ MHz} \leq \Delta f < 3 \text{ MHz}$	$0.05 \text{ MHz} \leq f_{\text{offset}} < 3.05 \text{ MHz}$	$P_{\text{rated,c,TRP}} - 49 \text{ dB} - (10/3) * (f_{\text{offset}} - 0.05) \text{ dB}$	100 kHz
$3 \text{ MHz} \leq \Delta f < 6 \text{ MHz}$	$3.05 \text{ MHz} \leq f_{\text{offset}} < 6.05 \text{ MHz}$	$P_{\text{rated,c,TRP}} - 59 \text{ dB}$	100 kHz
$6 \text{ MHz} \leq \Delta f \leq \Delta f_{\text{max}}$	$6.05 \text{ MHz} \leq f_{\text{offset}} < f_{\text{offset}_{\text{max}}}$	$\text{Min}(P_{\text{rated,c,TRP}} - 59 \text{ dB}, -16 \text{ dBm})$	100 kHz

NOTE 1: For a RIB supporting *non-contiguous spectrum* operation within any operating band the *minimum requirement* within *sub-block gaps* is calculated as a cumulative sum of contributions from adjacent sub blocks on each side of the *sub-block gap*. Exception is  $\Delta f \geq 10 \text{ MHz}$  from both adjacent sub blocks on each side of the *sub-block gap*, where the *minimum requirement* within *sub-block gaps* shall be  $\text{Min}(P_{\text{rated,c,TRP}} - 59 \text{ dB}, -16 \text{ dBm})/100 \text{ kHz}$ .

NOTE 2: For a *multi-band RIB* with *Inter RF Bandwidth gap*  $< 2 * \Delta f_{\text{OBUE}}$  the *minimum requirement* within the *Inter RF Bandwidth gaps* is calculated as a cumulative sum of contributions from adjacent sub-blocks or *Base Station RF Bandwidth* on each side of the *Inter RF Bandwidth gap*.

**Table 9.7.5.4.5-4: Medium Range BS operating band unwanted emission limits for 3 MHz channel bandwidth,  $P_{\text{rated,c,TRP}} \leq 40$  dBm**

Frequency offset of measurement filter -3dB point, $\Delta f$	Frequency offset of measurement filter centre frequency, $f_{\text{offset}}$	Minimum requirement (NOTE 1, 2)	Measurement bandwidth (NOTE 7)
$0 \text{ MHz} \leq \Delta f < 3 \text{ MHz}$	$0.05 \text{ MHz} \leq f_{\text{offset}} < 3.05 \text{ MHz}$	$-9\text{dBm} - \frac{10}{3} \left( \frac{f_{\text{offset}}}{\text{MHz}} - 0.05 \right) \text{dB}$	100 kHz
$3 \text{ MHz} \leq \Delta f < 6 \text{ MHz}$	$3.05 \text{ MHz} \leq f_{\text{offset}} < 6.05 \text{ MHz}$	-19 dBm	100 kHz
$6 \text{ MHz} \leq \Delta f \leq \Delta f_{\text{max}}$	$6.05 \text{ MHz} \leq f_{\text{offset}} < f_{\text{offset}_{\text{max}}}$	-19 dBm	100 kHz

NOTE 1: For a RIB supporting *non-contiguous spectrum* operation within any operating band the *minimum requirement* within *sub-block gaps* is calculated as a cumulative sum of contributions from adjacent sub blocks on each side of the *sub-block gap*. Exception is  $\Delta f \geq 10\text{MHz}$  from both adjacent sub blocks on each side of the *sub-block gap*, where the *minimum requirement* within *sub-block gaps* shall be -19dBm/100kHz.

NOTE 2: For a *multi-band RIB* with *Inter RF Bandwidth gap*  $< 2 \times \Delta f_{\text{OBUE}}$  the *minimum requirement* within the *Inter RF Bandwidth gaps* is calculated as a cumulative sum of contributions from adjacent sub-blocks or *Base Station RF Bandwidth* on each side of the *Inter RF Bandwidth gap*.

**Table 9.7.5.4.5-5: Medium Range BS operating band unwanted emission limits for 5, 10, 15 and 20 MHz channel bandwidth,  $40 < P_{\text{rated,c,TRP}} \leq 47$  dBm**

Frequency offset of measurement filter -3dB point, $\Delta f$	Frequency offset of measurement filter centre frequency, $f_{\text{offset}}$	Minimum requirement (NOTE 1, 2)	Measurement bandwidth (NOTE 7)
$0 \text{ MHz} \leq \Delta f < 5 \text{ MHz}$	$0.05 \text{ MHz} \leq f_{\text{offset}} < 5.05 \text{ MHz}$	$P_{\text{rated,c,TRP}} - 53\text{dB} - (7/5) * (f_{\text{offset}} - 0.05) \text{dB}$	100 kHz
$5 \text{ MHz} \leq \Delta f < \min(10 \text{ MHz}, \Delta f_{\text{max}})$	$5.05 \text{ MHz} \leq f_{\text{offset}} < \min(10.05 \text{ MHz}, f_{\text{offset}_{\text{max}}})$	$P_{\text{rated,c,TRP}} - 60\text{dB}$	100 kHz
$10 \text{ MHz} \leq \Delta f \leq \Delta f_{\text{max}}$	$10.05 \text{ MHz} \leq f_{\text{offset}} < f_{\text{offset}_{\text{max}}}$	$\text{Min}(P_{\text{rated,c,TRP}} - 60\text{dB}, -16\text{dBm})$ (NOTE 6)	100 kHz

NOTE 1: For a RIB supporting *non-contiguous spectrum* operation within any operating band the *minimum requirement* within *sub-block gaps* is calculated as a cumulative sum of contributions from adjacent sub blocks on each side of the *sub-block gap*. Exception is  $\Delta f \geq 10\text{MHz}$  from both adjacent sub blocks on each side of the *sub-block gap*, where the *minimum requirement* within *sub-block gaps* shall be  $\text{Min}(P_{\text{rated,c,TRP}} - 60\text{dB}, -16\text{dBm})/100\text{kHz}$ .

NOTE 2: For a *multi-band RIB* with *Inter RF Bandwidth gap*  $< 2 \times \Delta f_{\text{OBUE}}$  the *minimum requirement* within the *Inter RF Bandwidth gaps* is calculated as a cumulative sum of contributions from adjacent sub-blocks or *Base Station RF Bandwidth* on each side of the *Inter RF Bandwidth gap*.

**Table 9.7.5.4.5-6: Medium Range BS operating band unwanted emission limits for 5, 10, 15 and 20 MHz channel bandwidth,  $P_{\text{rated,c,TRP}} \leq 40$  dBm**

Frequency offset of measurement filter -3dB point, $\Delta f$	Frequency offset of measurement filter centre frequency, $f_{\text{offset}}$	Minimum requirement (NOTE 1, 2)	Measurement bandwidth (NOTE 7)
$0 \text{ MHz} \leq \Delta f < 5 \text{ MHz}$	$0.05 \text{ MHz} \leq f_{\text{offset}} < 5.05 \text{ MHz}$	$P_{\text{rated,c,TRP}} - 13\text{dB} - (7/5) * (f_{\text{offset}} - 0.05) \text{dB}$	100 kHz
$5 \text{ MHz} \leq \Delta f < \min(10 \text{ MHz}, \Delta f_{\text{max}})$	$5.05 \text{ MHz} \leq f_{\text{offset}} < \min(10.05 \text{ MHz}, f_{\text{offset}_{\text{max}}})$	-20 dBm	100 kHz
$10 \text{ MHz} \leq \Delta f \leq \Delta f_{\text{max}}$	$10.05 \text{ MHz} \leq f_{\text{offset}} < f_{\text{offset}_{\text{max}}}$	-20 dBm (NOTE 8)	100 kHz

NOTE 1: For a RIB supporting *non-contiguous spectrum* operation within any operating band the *minimum requirement* within *sub-block gaps* is calculated as a cumulative sum of contributions from adjacent sub blocks on each side of the *sub-block gap*. Exception is  $\Delta f \geq 10\text{MHz}$  from both adjacent sub blocks on each side of the *sub-block gap*, where the *minimum requirement* within *sub-block gaps* shall be -20dBm/100kHz.

NOTE 2: For a *multi-band RIB* with *Inter RF Bandwidth gap*  $< 2 \times \Delta f_{\text{OBUE}}$  the *minimum requirement* within the *Inter RF Bandwidth gaps* is calculated as a cumulative sum of contributions from adjacent sub-blocks or *Base Station RF Bandwidth* on each side of the *Inter RF Bandwidth gap*.

### 9.7.5.4.6 Additional requirements

#### 9.7.5.4.6.1 Additional operating band unwanted emission limits for E-UTRA bands

These requirements may be applied for the protection of other systems operating inside or near each supported E-UTRA, E-UTRA with NB-IoT and NB-IoT BS downlink operating band. The limits may apply as an optional protection of such systems that are deployed in the same geographical area as the E-UTRA BS, or they may be set by local or regional regulation as a mandatory requirement for an E-UTRA operating band. It is in some cases not stated in the present document whether a requirement is mandatory or under what exact circumstances that a limit applies, since this is set by local or regional regulation. An overview of regional requirements in the present document is given in subclause 4.3.

In certain regions the following requirement may apply. For E-UTRA, emissions shall not exceed the maximum levels specified in Tables 9.7.5.4.6.1-1.

**Table 9.7.5.4.6.1-1: Additional operating band unwanted emission limits for E-UTRA bands <1GHz**

Channel bandwidth	Frequency offset of measurement filter -3dB point, $\Delta f$	Frequency offset of measurement filter centre frequency, $f_{\text{offset}}$	Minimum requirement	Measurement bandwidth (Note 8)
200 kHz	$0 \text{ MHz} \leq \Delta f < 1 \text{ MHz}$	$0.005 \text{ MHz} \leq f_{\text{offset}} < 0.995 \text{ MHz}$	-6 dBm	10 kHz
1.4 MHz	$0 \text{ MHz} \leq \Delta f < 1 \text{ MHz}$	$0.005 \text{ MHz} \leq f_{\text{offset}} < 0.995 \text{ MHz}$	-14 dBm	10 kHz
3 MHz	$0 \text{ MHz} \leq \Delta f < 1 \text{ MHz}$	$0.015 \text{ MHz} \leq f_{\text{offset}} < 0.985 \text{ MHz}$	-13 dBm	30 kHz
5 MHz	$0 \text{ MHz} \leq \Delta f < 1 \text{ MHz}$	$0.015 \text{ MHz} \leq f_{\text{offset}} < 0.985 \text{ MHz}$	-15 dBm	30 kHz
10 MHz	$0 \text{ MHz} \leq \Delta f < 1 \text{ MHz}$	$0.05 \text{ MHz} \leq f_{\text{offset}} < 0.95 \text{ MHz}$	-13 dBm	100 kHz
15 MHz	$0 \text{ MHz} \leq \Delta f < 1 \text{ MHz}$	$0.05 \text{ MHz} \leq f_{\text{offset}} < 0.95 \text{ MHz}$	-13 dBm	100 kHz
20 MHz	$0 \text{ MHz} \leq \Delta f < 1 \text{ MHz}$	$0.05 \text{ MHz} \leq f_{\text{offset}} < 0.95 \text{ MHz}$	-13 dBm	100 kHz
All	$1 \text{ MHz} \leq \Delta f < \Delta f_{\text{max}}$	$1.05 \text{ MHz} \leq f_{\text{offset}} < f_{\text{offset}_{\text{max}}}$	-13 dBm	100 kHz

In certain regions the following requirement may apply. For E-UTRA BS operating in Bands 2, 4, 10, 23, 25, 30, 35, 36, 41, 66, 70, emissions shall not exceed the maximum levels specified in Table 9.7.5.4.6.1-2.

**Table 9.7.5.4.6.1-2: Additional operating band unwanted emission limits for E-UTRA bands >1GHz**

Channel bandwidth	Frequency offset of measurement filter -3dB point, $\Delta f$	Frequency offset of measurement filter centre frequency, $f_{\text{offset}}$	Minimum requirement	Measurement bandwidth (Note 8)
1.4 MHz	$0 \text{ MHz} \leq \Delta f < 1 \text{ MHz}$	$0.005 \text{ MHz} \leq f_{\text{offset}} < 0.995 \text{ MHz}$	-14 dBm	10 kHz
3 MHz	$0 \text{ MHz} \leq \Delta f < 1 \text{ MHz}$	$0.015 \text{ MHz} \leq f_{\text{offset}} < 0.985 \text{ MHz}$	-13 dBm	30 kHz
5 MHz	$0 \text{ MHz} \leq \Delta f < 1 \text{ MHz}$	$0.015 \text{ MHz} \leq f_{\text{offset}} < 0.985 \text{ MHz}$	-15 dBm	30 kHz
10 MHz	$0 \text{ MHz} \leq \Delta f < 1 \text{ MHz}$	$0.05 \text{ MHz} \leq f_{\text{offset}} < 0.95 \text{ MHz}$	-13 dBm	100 kHz
15 MHz	$0 \text{ MHz} \leq \Delta f < 1 \text{ MHz}$	$0.05 \text{ MHz} \leq f_{\text{offset}} < 0.95 \text{ MHz}$	-15 dBm	100 kHz
20 MHz	$0 \text{ MHz} \leq \Delta f < 1 \text{ MHz}$	$0.05 \text{ MHz} \leq f_{\text{offset}} < 0.95 \text{ MHz}$	-16 dBm	100 kHz
All	$1 \text{ MHz} \leq \Delta f < \Delta f_{\text{max}}$	$1.5 \text{ MHz} \leq f_{\text{offset}} < f_{\text{offset}_{\text{max}}}$	-13 dBm	1 MHz

In certain regions the following requirement may apply. For E-UTRA BS operating in Bands 12, 13, 14, 17, 29, 71, 85 emissions shall not exceed the maximum levels specified in Table 9.7.5.4.6.1-3.

**Table 9.7.5.4.6.1-3: Additional operating band unwanted emission limits for E-UTRA (bands 12, 13, 14, 17, 29, 71 and 85)**

Channel bandwidth	Frequency offset of measurement filter -3dB point, $\Delta f$	Frequency offset of measurement filter centre frequency, $f_{\text{offset}}$	Minimum requirement	Measurement bandwidth (Note 8)
All	$0 \text{ MHz} \leq \Delta f < 100 \text{ kHz}$	$0.015 \text{ MHz} \leq f_{\text{offset}} < 0.085 \text{ MHz}$	-13 dBm	30 kHz
All	$100 \text{ kHz} \leq \Delta f < \Delta f_{\text{max}}$	$150 \text{ kHz} \leq f_{\text{offset}} < f_{\text{offset}_{\text{max}}}$	-13 dBm	100 kHz

In certain regions, the following requirements may apply to an E-UTRA, E-UTRA with NB-IoT and NB-IoT TDD BS operating in the same geographic area and in the same operating band as another E-UTRA TDD system without

synchronisation. For this case the emissions shall not exceed -52 dBm/MHz in each supported downlink operating band except in:

- The frequency range from 10 MHz below the lower channel edge to the frequency 10 MHz above the upper channel edge of each supported band.

#### 9.7.5.4.6.2 Protection of DTT

In certain regions the following requirement may apply for protection of DTT. For an AAS BS operating in Band 20, the level of emissions in the band 470-790 MHz, measured in an 8 MHz filter bandwidth on centre frequencies  $F_{\text{filter}}$  according to table 9.7.5.4.6.2-1, shall not exceed the maximum emission TRP level shown in the table. This requirement applies in the frequency range 470-790 MHz even though part of the range falls in the spurious domain.

**Table 9.7.5.4.6.2-1: Declared emissions levels for protection of DTT**

Case	Measurement filter centre frequency	Condition on BS maximum aggregate TRP / 10 MHz, $P_{\text{TRP}_10\text{MHz}}$ (NOTE)	Maximum Level $P_{\text{TRP}_N,\text{MAX}}$	Measurement Bandwidth
A: for DTT frequencies where broadcasting is protected	$N*8 + 306 \text{ MHz}$ , $21 \leq N \leq 60$	$P_{\text{TRP}_10\text{MHz}} \geq 59 \text{ dBm}$	0 dBm	8 MHz
	$N*8 + 306 \text{ MHz}$ , $21 \leq N \leq 60$	$36 \leq P_{\text{TRP}_10\text{MHz}} < 59 \text{ dBm}$	$P_{\text{TRP}_10\text{MHz}} - 59 \text{ dBm}$	8 MHz
	$N*8 + 306 \text{ MHz}$ , $21 \leq N \leq 60$	$P_{\text{TRP}_10\text{MHz}} < 36 \text{ dBm}$	-23 dBm	8 MHz
B: for DTT frequencies where broadcasting is subject to an intermediate level of protection	$N*8 + 306 \text{ MHz}$ , $21 \leq N \leq 60$	$P_{\text{TRP}_10\text{MHz}} \geq 59 \text{ dBm}$	10 dBm	8 MHz
	$N*8 + 306 \text{ MHz}$ , $21 \leq N \leq 60$	$36 \leq P_{\text{TRP}_10\text{MHz}} < 59 \text{ dBm}$	$P_{\text{TRP}_10\text{MHz}} - 49 \text{ dBm}$	8 MHz
	$N*8 + 306 \text{ MHz}$ , $21 \leq N \leq 60$	$P_{\text{TRP}_10\text{MHz}} < 36 \text{ dBm}$	-13 dBm	8 MHz
C: for DTT frequencies where broadcasting is not protected	$N*8 + 306 \text{ MHz}$ , $21 \leq N \leq 60$	N.A.	22 dBm	8 MHz
NOTE:	$P_{\text{TRP}_10\text{MHz}}$ (dBm) is defined by the expression $P_{\text{TRP}_10\text{MHz}} = P_{10\text{MHz}} + G_{\text{ant}} + 6\text{dB}$ for UTRA and $P_{\text{TRP}_10\text{MHz}} = P_{10\text{MHz}} + G_{\text{ant}} + 9\text{dB}$ for E-UTRA, where $G_{\text{ant}}$ is 17 dBi			

NOTE: The regional requirement is defined in terms of EIRP (effective isotropic radiated power), which is dependent on both the BS emissions and the deployment (including antenna gain and feeder loss). The method outlined in annex B1 Indicates how the limit in table 9.7.5.4.6.2-1 demonstrates compliance to the regional requirement.

#### 9.7.5.4.6.3 Co-existence with RNSS/GPS services in North America

In regions where FCC regulation applies, requirements for protection of GPS according to FCC Order DA 20-48 applies for operation in Band 24. The following normative requirement covers the base station, to be used together with other information about the site installation to verify compliance with the requirement in FCC Order DA 20-48. The requirement applies to BS operating in Band 24 to ensure that appropriate interference protection is provided to the GPS. This requirement applies in the frequency range 1541-1650 MHz even though part of the range falls in the spurious domain.

The level of emissions in the 1541 – 1650 MHz band, measured in measurement bandwidth according to table 9.7.5.4.6.3-1 shall not exceed the maximum TRP limits indicated in the table.

**Table 9.7.5.4.6.3-1: Emissions levels for protection of the 1541-1650 MHz band**

Operating Band	Frequency range (MHz)	Emission level (dBW) (Measurement bandwidth = 1 MHz)	Emission level (dBW) of discrete emissions of less than 700 Hz bandwidth (Measurement bandwidth = 1 kHz)	Emission level (dBW) of discrete emissions of less than 2 kHz bandwidth (Measurement bandwidth = 1 kHz)
24	1541 - 1559	$P_{\text{EIRP}} - 17 \text{ dBi} + 9 \text{ dB}$		$P_{\text{EIRP}} - 17 \text{ dBi} + 9 \text{ dB}$
	1559 - 1610	$P_{\text{EIRP}} - 17 \text{ dBi} + 9 \text{ dB}$	$P_{\text{EIRP}} - 17 \text{ dBi} + 9 \text{ dB}$	
	1610 - 1650	$P_{\text{EIRP}} - 17 \text{ dBi} + 9 \text{ dB}$	$P_{\text{EIRP}} - 17 \text{ dBi} + 9 \text{ dB}$	

NOTE: The regional requirements, included in FCC Order DA 20-48 are defined in terms of EIRP (effective isotropic radiated power), which is dependent on both the BS emissions at the antenna connector and the deployment (including antenna gain and feeder loss). The method outlined in annex B1 indicates how the limit in table 9.7.5.4.6.3-1 demonstrates compliance to the regional requirement.  $P_{\text{EIRP}}$  values in table 9.7.5.4.6.3-1 are the effective isotropic power (or radiated power spectral density) set in the FCC Order DA 20-48 for the specified frequency ranges and bandwidths.

9.7.5.4.6.4 Void

**Table 9.7.5.4.6.4-1: Void**

9.7.5.4.6.5 Additional band 32, 50, 51, 74, 75 and 76 unwanted emissions

In certain regions, the following requirements may apply to BS operating in Band 32 within 1452-1492 MHz, in Band 75 within 1432-1517 MHz and in Band 76 within 1427-1432 MHz. The level of operating band unwanted emissions, measured on centre frequencies  $f_{\text{offset}}$  with filter bandwidth, according to table 9.7.5.4.6.5-1, shall not exceed the maximum TRP limits indicated in the table..

For Band 32, this requirement applies in the frequency range 1452-1492 MHz when non-Mobile/Fixed Communications Network (MFCN) services are deployed in adjacent frequency ranges, while it applies also within 1427-1452 MHz and/or 1492-1517 MHz when MFCN services are deployed in such frequency ranges, even though part of the ranges falls in the spurious domain. For Band 75, this requirement applies in the frequency range 1427-1517 MHz. For Band 76, this requirement applies in the frequency range 1432-1517 MHz even though part of the range falls in the spurious domain.

**Table 9.7.5.4.6.5-1: Declared operating band 32, 75 and 76 unwanted emission within 1427-1517 MHz**

Frequency offset of measurement filter centre frequency, $f_{\text{offset}}$	Declared emission level [dBm]	Measurement bandwidth
2.5 MHz	$P_{\text{EIRP}} - 17 \text{ dBi} + 9 \text{ dB}$	5 MHz
7.5 MHz	$P_{\text{EIRP}} - 17 \text{ dBi} + 9 \text{ dB}$	5 MHz
$12.5 \text{ MHz} \leq f_{\text{offset}} \leq f_{\text{offset}_{\text{max}}}$	$P_{\text{EIRP}} - 17 \text{ dBi} + 9 \text{ dB}$	5 MHz
NOTE: For Band 32, when non-MFCN services are deployed in the adjacent bands, $f_{\text{offset}_{\text{max}}}$ denotes the frequency difference between the lower Base Station RF Bandwidth edge and 1454.5 MHz, and the frequency difference between the upper Base Station RF Bandwidth edge and 1489.5 MHz for the set channel position. For Band 32, when MFCN services are deployed in the adjacent frequencies, Band 75 and Band 76, $f_{\text{offset}_{\text{max}}}$ denotes the frequency difference between the lower Base Station RF Bandwidth edge and 1429.5 MHz, and the frequency difference between the upper Base Station RF Bandwidth edge and 1514.5 MHz for the set channel position.		

NOTE: The regional requirement is defined in terms of EIRP (effective isotropic radiated power), which is dependent on both the BS emissions at the antenna connector and the deployment (including antenna gain and feeder loss). The method outlined in annex B.1 indicates how the limit in table 9.7.5.4.6.5-1 demonstrates compliance to the regional requirement.

In certain regions, the following requirement may apply to BS operating in Band 32 within 1452-1492MHz for the protection of non-MFCN services in spectrum adjacent to the frequency range 1452-1492 MHz. The level of emissions, measured on centre frequencies  $F_{\text{filter}}$  with filter bandwidth according to Table 9.7.5.4.6.5-2, shall not exceed the maximum TRP limits indicated in the table. This requirement applies in the frequency range 1429-1518MHz even though part of the range falls in the spurious domain.

**Table 9.7.5.4.6.5-2: Operating band 32 declared emission outside 1452-1492 MHz**

Filter centre frequency, $F_{\text{filter}}$	Declared emission level [dBm]	Measurement bandwidth
$1429.5 \text{ MHz} \leq F_{\text{filter}} \leq 1448.5 \text{ MHz}$	$P_{\text{EIRP}} - 17 \text{ dBi} + 9 \text{ dB}$	1 MHz
$F_{\text{filter}} = 1450.5 \text{ MHz}$	$P_{\text{EIRP}} - 17 \text{ dBi} + 9 \text{ dB}$	3 MHz
$F_{\text{filter}} = 1493.5 \text{ MHz}$	$P_{\text{EIRP}} - 17 \text{ dBi} + 9 \text{ dB}$	3 MHz
$1495.5 \text{ MHz} \leq F_{\text{filter}} \leq 1517.5 \text{ MHz}$	$P_{\text{EIRP}} - 17 \text{ dBi} + 9 \text{ dB}$	1 MHz

NOTE: The regional requirement is defined in terms of EIRP (effective isotropic radiated power), which is dependent on both the BS emissions at the antenna connector and the deployment (including antenna gain and feeder loss). The method outlined in annex B.1 indicates how the limit in table 9.7.5.4.6.5-2 demonstrates compliance to the regional requirement.

In certain regions, the following requirement may apply to BS operating in Band 50 and Band 75 within 1492-1517 MHz and in Band 74 within 1492-1518 MHz. The level of emissions, measured on centre frequencies  $F_{\text{filter}}$  with filter bandwidth according to table 9.7.5.4.6.5-3, shall not exceed the maximum TRP limits indicated in the table.

**Table 9.7.5.4.6.5-3: Operating band 50, 74 and 75 declared emission above 1520 MHz**

Filter centre frequency, $F_{\text{filter}}$	Declared emission level [dBm]	Measurement bandwidth
$1520.5 \text{ MHz} \leq F_{\text{filter}} \leq 1558.5 \text{ MHz}$	$P_{\text{EIRP}} - 17 \text{ dBi} + 9 \text{ dB}$	1 MHz

NOTE: The regional requirement is defined in terms of EIRP (effective isotropic radiated power), which is dependent on both the BS emissions at the antenna connector and the deployment (including antenna gain and feeder loss). The method outlined in annex B.1 indicates how the limit in table 9.7.5.4.6.5-3 demonstrates compliance to the regional requirement.

In certain regions, the following requirement may apply to E-UTRA BS operating in Band 50 and Band 75 within 1432-1452 MHz, and in Band 51 and Band 76. Emissions shall not exceed the maximum levels specified in table 9.7.5.4.6.5-4.

**Table 9.7.5.4.6.5-4: Additional operating band unwanted emission limits for BS operating in Band 50 and 75 within 1432-1452 MHz, and in Band 51 and 76**

Filter centre frequency, $F_{\text{filter}}$	Maximum Level [dBm]	Measurement Bandwidth
$F_{\text{filter}} = 1413.5 \text{ MHz}$	-33	27 MHz

#### 9.7.5.4.6.6 Additional requirements for band 45

In certain regions the following requirement may apply to E-UTRA BS operating in Band 45. Emissions shall not exceed the maximum levels specified in table 9.7.5.4.6.6-1.

**Table 9.7.5.4.6.6-1: Emissions limits for protection of adjacent band services**

Operating Band	Filter centre frequency, $F_{\text{filter}}$	Maximum Level [dBm]	Measurement Bandwidth
45	$F_{\text{filter}} = 1467.5$	-11	1 MHz
	$F_{\text{filter}} = 1468.5$	-14	1 MHz
	$F_{\text{filter}} = 1469.5$	-17	1 MHz
	$F_{\text{filter}} = 1470.5$	-24	1 MHz
	$F_{\text{filter}} = 1471.5$	-31	1 MHz
	$1472.5 \text{ MHz} \leq F_{\text{filter}} \leq 1491.5 \text{ MHz}$	-38	1 MHz

#### 9.7.5.4.6.7 Additional requirements for band 48

The following requirement may apply to BS operating in Band 48 in certain regions. Emissions shall not exceed the maximum levels specified in table 9.7.5.4.6.7-1.

**Table 9.7.5.4.6.7-1: Additional operating band unwanted emission limits for Band 48**

Channel bandwidth	Frequency offset of measurement filter -3dB point, $\Delta f$	Frequency offset of measurement filter centre frequency, $f_{\text{offset}}$	Minimum requirement	Measurement bandwidth
All	$0 \text{ MHz} \leq \Delta f < 10 \text{ MHz}$	$0.5 \text{ MHz} \leq f_{\text{offset}} < 9.5 \text{ MHz}$	-4 dBm	1 MHz

## 9.7.6 OTA Spurious emission

### 9.7.6.1 General

The OTA spurious emissions limits are specified as TRP per *RIB* unless otherwise specified.

The OTA transmitter spurious emission limits apply from 30 MHz to 12.75 GHz, excluding the following RAT-specific frequency ranges:

- UTRA FDD BS as specified in TS 25.104 [2]: from 12.5MHz below the lowest carrier frequency used up to 12.5MHz above the highest carrier frequency used.
- E-UTRA BS as specified in TS 36.104 [4]: from  $\Delta f_{\text{OBUE}}$  below the lowest frequency of the *downlink operating band* up to  $\Delta f_{\text{OBUE}}$  above the highest frequency of the *downlink operating band*, where  $\Delta f_{\text{OBUE}}$  is defined in subclause 9.7.1.
- MSR BS as specified in TS 37.104 [5]: from  $\Delta f_{\text{OBUE}}$  below the lowest frequency of the *downlink operating band* up to  $\Delta f_{\text{OBUE}}$  above the highest frequency of the *downlink operating band*, where  $\Delta f_{\text{OBUE}}$  is defined in subclause 9.7.1.

For some operating bands the upper frequency limit is higher than 12.75 GHz in order to comply with the 5<sup>th</sup> harmonic limit of the *downlink operating band*, as specified in ITU-R recommendation SM.329 [14]. In some exceptional cases, requirements apply also closer than  $\Delta f_{\text{OBUE}}$  MHz from the *downlink operating band*; these cases are highlighted in the requirement tables in respective referenced UTRA, E-UTRA or MSR specifications. For operating bands supported by *multi-band RIB* each supported band including the  $\Delta f_{\text{OBUE}}$  around the band are excluded from the spurious emissions requirements.

The requirements applies for both *single band RIBs* and *multi-band RIBs* (except for frequencies at which exclusion bands or other multi-band provisions apply) and for all transmission modes foreseen by the manufacturer's specification. Unless otherwise stated, all requirements are measured as mean power.

For operation in Region 2, where the FCC guidance for MIMO systems in [18] is applicable, the emissions limits are the same regardless of the number of transceiver units so the limits are equivalent to those for a single transceiver unit as specified in the as the corresponding applicable *non-AAS BS* per transmitter requirement specified in 3GPP TS 25.104 [2], 3GPP TS 25.105 [3], 3GPP TS 36.104 [4] or 3GPP TS 37.104 [5]. For E-UTRA the limits will be 9dB lower and for UTRA FDD the limits will be 6 dB lower, unless stated differently in regional regulation.

The AAS BS requirements for spurious emissions limits which are specified for Band 46 or for Band 49 in 3GPP TS 37.104 [5], are applicable for AAS BS.

For BS operating in bands n50, n51, n74, n75 and n76 additional emission limits that might be applicable in the spurious emissions frequency domain are specified in clause 9.7.5.2.4.7.

## 9.7.6.2 MSR operation

### 9.7.6.2.1 Minimum requirement for MSR operation

#### 9.7.6.2.1.1 Minimum requirement (Category A)

The TRP of any spurious emission shall not exceed the limits in table 9.7.6.2.1.1-1

**Table 9.7.6.2.1.1-1: AAS BS OTA Spurious emission limits, Category A**

Frequency range	Maximum level	Measurement bandwidth	NOTE
30MHz - 1GHz	-13 + X dBm	100 kHz	NOTE 1
1GHz - 12.75 GHz		1 MHz	NOTE 1, NOTE 2
12.75 GHz – 5 <sup>th</sup> harmonic of the upper frequency edge of the DL operating band in GHz		1 MHz	NOTE 1, NOTE 2, NOTE 3
NOTE 1: <i>Measurement bandwidths</i> as in ITU-R SM.329 [14], s4.1 NOTE 2: Upper frequency as in ITU-R SM.329 [14] , s2.5 table 1 NOTE 3: This spurious frequency range applies only for <i>operating bands</i> for which the 5 <sup>th</sup> harmonic of the upper frequency edge of the UL <i>operating band</i> is reaching beyond 12.75 GHz. NOTE 4: X = 9 dB for E-UTRA, X = 6 dB for UTRA, unless stated differently in regional regulation. NOTE 5: The frequency range from $F_{BW\ RF, DL, low} - \Delta f_{OBUE}$ (i.e. $\Delta f_{OBUE}$ below the lowest frequency of the BS transmitter <i>operating band</i> ) to $F_{BW\ RF, DL, high} + \Delta f_{OBUE}$ (i.e. $\Delta f_{OBUE}$ above the highest frequency of the BS transmitter <i>operating band</i> ) may be excluded from the requirement. $\Delta f_{OBUE}$ is defined in clause 6.6.1. For a <i>multiband RIB</i> , the exclusion applies for all supported operating bands.			

#### 9.7.6.2.1.2 Minimum requirement (Category B)

For UTRA, the minimum requirement is specified in subclause 9.7.6.3.1.2

For E-UTRA, the minimum requirement is specified in subclause 9.7.6.4.1.2

For NR, the minimum requirement is specified in 3GPP TS 38.104 [27] in subclause 9.7.5.2.2.

#### 9.7.6.2.1.3 (void)

### 9.7.6.2.2 Protection of the BS receiver of own or different BS

This requirement shall be applied for FDD operation in order to prevent the receivers of own or a different BS of the same band being desensitised by emissions from a *OTA AAS BS*.

The requirement is a co-location requirement. The power levels are specified at the *co-location reference antenna* output.

The power sum of any spurious emissions is specified over all supported polarizations of the *co-location reference antenna* and shall not exceed the limits in table 9.7.6.2.2-1 depending on the declared Base Station class and Band Category.

**Table 9.7.6.2.2-1: BS Spurious emissions limits for protection of the BS receiver**

BS-class	Band category	Frequency range	Maximum Level	Measurement Bandwidth	NOTE
Wide Area BS	BC1	$F_{UL\_low} - F_{UL\_high}$	-117 dBm	100 kHz	
Wide Area BS	BC2	$F_{UL\_low} - F_{UL\_high}$	-119 dBm	100 kHz	
Medium Range BS	BC1,BC2	$F_{UL\_low} - F_{UL\_high}$	-112 dBm	100 kHz	
Local Area BS	BC1,BC2	$F_{UL\_low} - F_{UL\_high}$	-109 dBm	100 kHz	
NOTE 1: For BS operating in regions where a band is only partially allocated for E-UTRA/NR operations (e.g. band 28), this requirement only applies in the UL frequency range of the partial allocation.					
NOTE 2: For BS capable of multi-band operation, Table 9.7.6.2.2-1 assumes that the supported <i>operating bands</i> , where the corresponding BS transmit and receive frequency ranges in TS 37.104 [5] Table 4.5-1 or Table 4.5-2 would be overlapping, are not deployed in the same geographical area. For such a case of operation with overlapping frequency arrangements in the same geographical area, special protection requirements may apply that are not covered by the 3GPP specifications.					

### 9.7.6.2.3 Additional spurious emissions requirements

For UTRA, the minimum requirement is specified in subclause 9.7.6.3.3

For E-UTRA, the minimum requirement is specified in subclause 9.7.6.4.3

For NR, the minimum requirement is specified in 3GPP TS 38.104 [27] subclause 9.7.5.2.4.

### 9.7.6.2.4 Co-location with other base stations

For UTRA, the minimum requirement for Co-location with other base stations is specified in subclause 9.7.6.3.4

For E-UTRA, the minimum requirement for Co-location with other base stations is specified in subclause 9.7.6.4.4

For NR, the minimum requirement for Co-location with other base stations is specified in 3GPP TS 38.104 [27] subclause 9.7.5.2.5

## 9.7.6.3 Minimum requirement for single RAT UTRA operation

### 9.7.6.3.1 Mandatory Requirements

#### 9.7.6.3.1.1 Minimum requirement (Category A)

The minimum requirement for single RAT UTRA BS is the same as that defined for an MSR BS in subclause 9.7.6.2.1.1.

#### 9.7.6.3.1.2 Minimum requirement (Category B)

The following limits shall be met in cases where Category B limits for spurious emissions, as defined in ITU-R Recommendation SM.329 [17], are applied.

The TRP of any spurious emission shall not exceed the limits in table 9.7.6.2.1.1-2

**Table 9.7.6.3.1.2-1: OTA AAS BS Mandatory spurious emissions limits, operating band I, II, III, IV, VII, X, XXII, XXV, XXXII (Category B)**

Band	Maximum Level (Note 5)	Measurement Bandwidth	Notes
30 MHz ↔ 1 GHz	-36 + X dBm	100 kHz	NOTE 1
1 GHz ↔ $F_{low} - 10$ MHz	-30 + X dBm	1 MHz	NOTE 1
$F_{low} - 10$ MHz ↔ $F_{high} + 10$ MHz	-15 + X dBm	1 MHz	NOTE 2
$F_{high} + 10$ MHz ↔ 12.75 GHz	-30 + X dBm	1 MHz	NOTE 3
12.75 GHz - 5 <sup>th</sup> harmonic of the upper frequency edge of the DL operating band in GHz	-30 + X dBm	1 MHz	NOTE 3, NOTE 4
NOTE 1: Bandwidth as in ITU-R Recommendation SM.329 [14], s4.1			
NOTE 2: Limit based on ITU-R Recommendation SM.329 [14], s4.3 and Annex 7			
NOTE 3: Bandwidth as in ITU-R Recommendation SM.329 [14], s4.1. Upper frequency as in ITU-R SM.329 [17], s2.5 table 1			
NOTE 4: This spurious frequency range applies only for <i>operating bands</i> for which the 5 <sup>th</sup> harmonic of the upper frequency edge of the UL <i>operating band</i> is reaching beyond 12.75 GHz.			
NOTE 5: X = 6 dB, unless stated differently in regional regulation.			
Key:			
$F_{low}$ : The lowest downlink frequency of the operating band as defined in subclause 9.7.1			
$F_{high}$ : The highest downlink frequency of the operating band as defined in subclause 9.7.1			

**Table 9.7.6.3.1.2-2: BS Mandatory spurious emissions limits, operating band V, VIII, XII, XIII, XIV, XX, XXVI (Category B)**

Band	Maximum Level (Note 4)	Measurement Bandwidth	Notes
30 MHz ↔ $F_{low} - 10$ MHz	-36 + X dBm	100 kHz	NOTE 1
$F_{low} - 10$ MHz ↔ $F_{high} + 10$ MHz	-16 + X dBm	100 kHz	NOTE 2
$F_{high} + 10$ MHz ↔ 1 GHz	-36 + X dBm	100 kHz	NOTE 1
1GHz ↔ 12.75GHz	-30 + X dBm	1 MHz	NOTE 3
NOTE 1: Bandwidth as in ITU-R Recommendation SM.329 [17], s4.1			
NOTE 2: Limit based on ITU-R Recommendation SM.329 [17], s4.3 and Annex 7			
NOTE 3: Bandwidth as in ITU-R Recommendation SM.329 [17], s4.1. Upper frequency as in ITU-R SM.329 [17], s2.5 table 1			
NOTE 4: X = 6 dB, unless stated differently in regional regulation.			
Key:			
$F_{low}$ : The lowest downlink frequency of the operating band as defined in subclause 9.7.1			
$F_{high}$ : The highest downlink frequency of the operating band as defined in subclause 9.7.1			

### 9.7.6.3.2 Protection of the BS receiver of own or different BS

This requirement shall be applied for UTRA FDD operation in order to prevent the receivers of own or a different BS of the same band being desensitised by emissions from a *OTA AAS BS*.

The requirement is a co-location requirement. The power levels are specified at the *co-location reference antenna* output.

The power sum of any spurious emission is specified over all supported polarizations of the *co-location reference antenna* and shall not exceed the limits in table 9.7.6.3.2-1.

**Table 9.7.6.3.2-1: BS Spurious emissions limits for protection of the BS receiver**

	Frequency range	Maximum Level	Measurement Bandwidth	Notes
Wide Area BS	$F_{UL\_low} - F_{UL\_high}$	- 120 dBm	100 kHz	
Medium Range BS	$F_{UL\_low} - F_{UL\_high}$	- 110 dBm	100 kHz	
Local Area BS	$F_{UL\_low} - F_{UL\_high}$	-106 dBm	100 kHz	

### 9.7.6.3.3 Additional spurious emissions requirements

The TRP of any spurious emission shall not exceed the limits of table 9.7.6.3.3-1 for a AAS BS where requirements for co-existence with the system listed in the first column apply. For a *multi-band RIB*, the exclusions and conditions in the notes column of table 9.7.6.3.3-1 apply for each supported operating band.

**Table 9.7.6.3.3-1 *OTA AAS BS* Spurious emissions limits for UTRA FDD BS in geographic coverage area of systems operating in other frequency bands**

System type operating in the same geographical area	Band for co-existence requirement	Maximum Level	Measurement Bandwidth	Notes
GSM900	921 - 960 MHz	-51 dBm	100 kHz	This requirement does not apply to UTRA FDD operating in band VIII
	876 - 915 MHz	-55 dBm	100 kHz	For the frequency range 880-915 MHz, this requirement does not apply to UTRA FDD operating in band VIII, since it is already covered by the requirement in subclause 9.7.6.3.2.
DCS1800	1805 - 1880 MHz	-41 dBm	100 kHz	This requirement does not apply to UTRA FDD operating in band III
	1710 - 1785 MHz	-55 dBm	100 kHz	This requirement does not apply to UTRA FDD operating in band III, since it is already covered by the requirement in subclause 9.7.6.3.2.
PCS1900	1930 - 1990 MHz	-41 dBm	100 kHz	This requirement does not apply to UTRA FDD BS operating in frequency band II or band XXV
	1850 - 1910 MHz	-55 dBm	100 kHz	This requirement does not apply to UTRA FDD BS operating in frequency band II or band XXV, since it is already covered by the requirement in subclause 9.7.6.3.2.
GSM850 or CDMA850	869 - 894 MHz	-51 dBm	100 kHz	This requirement does not apply to UTRA FDD BS operating in frequency band V or XXVI
	824 - 849 MHz	-55 dBm	100 kHz	This requirement does not apply to UTRA FDD BS operating in frequency band V or XXVI, since it is already covered by the requirement in subclause 9.7.6.3.2.
UTRA FDD Band I or E-UTRA Band 1 or NR band n1	2110 - 2170 MHz	-46 dBm	1 MHz	This requirement does not apply to UTRA FDD BS operating in band I,
	1920 - 1980 MHz	-43 dBm	1 MHz	This requirement does not apply to UTRA FDD BS operating in band I, since it is already covered by the requirement in subclause 9.7.6.3.2.
UTRA FDD Band II or E-UTRA Band 2 or NR band n2	1930 - 1990 MHz	-46 dBm	1 MHz	This requirement does not apply to UTRA FDD BS operating in band II or band XXV
	1850 - 1910 MHz	-43 dBm	1 MHz	This requirement does not apply to UTRA FDD BS operating in band II or band XXV, since it is already covered by the requirement in subclause 9.7.6.3.2.
UTRA FDD Band III or E-UTRA Band 3 or NR band n3	1805 - 1880 MHz	-46 dBm	1 MHz	This requirement does not apply to UTRA FDD BS operating in band III or band IX
	1710 - 1785 MHz	-43 dBm	1 MHz	This requirement does not apply to UTRA FDD BS operating in band III, since it is already covered by the requirement in subclause 9.7.6.3.2. For UTRA BS operating in band IX, it applies for 1710 MHz to 1749.9 MHz and 1784.9 MHz to 1785 MHz, while the rest is covered in subclause 9.7.6.3.2.
UTRA FDD Band IV or E-UTRA Band 4	2110 - 2155 MHz	-46 dBm	1 MHz	This requirement does not apply to UTRA FDD BS operating in band IV or band X
	1710 - 1755 MHz	-43 dBm	1 MHz	This requirement does not apply to UTRA FDD BS operating in band IV or band X, since it is already covered by the requirement in subclause 9.7.6.3.2.
UTRA FDD Band V or E-UTRA Band 5 or NR band n5	869 - 894 MHz	-46 dBm	1 MHz	This requirement does not apply to UTRA FDD BS operating in band V or XXVI
	824 - 849 MHz	-43 dBm	1 MHz	This requirement does not apply to UTRA FDD BS operating in band V or XXVI, since it is already covered by the requirement in subclause 9.7.6.3.2.
UTRA FDD Band VI or XIX, E-UTRA Band 6, 18 or 19 or NR Band n18	860 - 890 MHz	-46 dBm	1 MHz	This requirement does not apply to UTRA FDD BS operating in band VI or XIX
	815 - 845 MHz	-43 dBm	1 MHz	This requirement does not apply to UTRA FDD BS operating in band VI or XIX, since it is already covered by the requirement in subclause 9.7.6.3.2.
UTRA FDD Band VII or E-UTRA Band 7 or NR band n7	2620 - 2690 MHz	-46 dBm	1 MHz	This requirement does not apply to UTRA FDD BS operating in band VII,
	2500 - 2570 MHz	-43 dBm	1 MHz	This requirement does not apply to UTRA FDD BS operating in band VII, since it is already covered by the requirement in subclause 9.7.6.3.2.
	925 - 960 MHz	-46 dBm	1 MHz	This requirement does not apply to UTRA FDD BS operating in band VIII.

UTRA FDD Band VIII or E-UTRA Band 8 or NR band n8	880 - 915 MHz	-43 dBm	1 MHz	This requirement does not apply to UTRA FDD BS operating in band VIII, since it is already covered by the requirement in subclause 9.7.6.3.2.
UTRA FDD Band IX or E-UTRA Band 9	1844.9 - 1879.9 MHz	-46 dBm	1 MHz	This requirement does not apply to UTRA FDD BS operating in band III or band IX
	1749.9 - 1784.9 MHz	-43 dBm	1 MHz	This requirement does not apply to UTRA FDD BS operating in band III or band IX, since it is already covered by the requirement in subclause 9.7.6.3.2.
UTRA FDD Band X or E-UTRA Band 10	2110 - 2170 MHz	-46 dBm	1 MHz	This requirement does not apply to UTRA FDD BS operating in band IV or band X.
	1710 - 1770 MHz	-43 dBm	1 MHz	This requirement does not apply to UTRA FDD BS operating in band X, since it is already covered by the requirement in subclause 9.7.6.3.2. For UTRA FDD BS operating in Band IV, it applies for 1755 MHz to 1770 MHz, while the rest is covered in subclause 9.7.6.3.2.
UTRA FDD Band XI or XXI or E-UTRA Band 11 or 21	1475.9 - 1510.9 MHz	-46 dBm	1 MHz	This requirement does not apply to UTRA FDD BS operating in band XI , XXI or XXXII.
	1427.9 - 1447.9 MHz	-43 dBm	1 MHz	This requirement does not apply to UTRA FDD BS operating in band XI, since it is already covered by the requirement in subclause 9.7.6.3.2. For UTRA BS operating in band XXXII, this requirement applies for carriers allocated within 1475.9MHz and 1495.9MHz.
	1447.9 - 1462.9 MHz	-43 dBm	1 MHz	This requirement does not apply to UTRA FDD BS operating in band XXI, since it is already covered by the requirement in subclause 9.7.6.3.2. For UTRA BS operating in band XXXII, this requirement applies for carriers allocated within 1475.9MHz and 1495.9MHz.
UTRA FDD Band XII or E-UTRA Band 12 or NR band n12	729 - 746 MHz	-46 dBm	1 MHz	This requirement does not apply to UTRA FDD BS operating in band XII
	699 - 716 MHz	-43 dBm	1 MHz	This requirement does not apply to UTRA FDD BS operating in band XII, since it is already covered by the requirement in subclause 9.7.6.3.2.
UTRA FDD Band XIII or E-UTRA Band 13 or NR band n13	746 - 756 MHz	-46 dBm	1 MHz	This requirement does not apply to UTRA FDD BS operating in band XIII
	777 - 787 MHz	-43 dBm	1 MHz	This requirement does not apply to UTRA FDD BS operating in band XIII, since it is already covered by the requirement in sub-clause 9.7.6.3.2.
UTRA FDD Band XIV or E-UTRA Band 14 or NR band n14	758 - 768 MHz	-46 dBm	1 MHz	This requirement does not apply to UTRA FDD BS operating in band XIV
	788 - 798 MHz	-43 dBm	1 MHz	This requirement does not apply to UTRA FDD BS operating in band XIV, since it is already covered by the requirement in subclause 9.7.6.3.2.
E-UTRA Band 17	734 - 746 MHz	-46 dBm	1 MHz	This requirement does not apply to UTRA FDD BS operating in band XII
	704 - 716 MHz	-43 dBm	1 MHz	This requirement does not apply to UTRA FDD BS operating in band XII, since it is already covered by the requirement in subclause 9.7.6.3.2.
UTRA FDD Band XX or E-UTRA Band 20 or NR band n20	791 - 821 MHz	-46 dBm	1 MHz	This requirement does not apply to UTRA FDD BS operating in band XX
	832 - 862 MHz	-43 dBm	1 MHz	This requirement does not apply to UTRA FDD BS operating in band XX, since it is already covered by the requirement in subclause 9.7.6.3.2.
UTRA FDD Band XXII or E-UTRA Band 22	3510 -3590 MHz	-46 dBm	1 MHz	This requirement does not apply to UTRA FDD BS operating in band XXII.
	3410 -3490 MHz	-43 dBm	1 MHz	This requirement does not apply to UTRA FDD BS operating in band XXII, since it is already covered by the requirement in subclause 9.7.6.3.2.
E-UTRA Band 24 or NR band n24	1525 – 1559 MHz	-46 dBm	1 MHz	
	1626.5 – 1660.5 MHz	-43 dBm	1 MHz	
	1930 - 1995 MHz	-46 dBm	1 MHz	This requirement does not apply to UTRA FDD BS operating in band II or band XXV

UTRA FDD Band XXV or E-UTRA Band 25 or NR band n25	1850 - 1915 MHz	-43 dBm	1 MHz	This requirement does not apply to UTRA FDD BS operating in band XXV, since it is already covered by the requirement in subclause 9.7.6.3.2. For UTRA FDD BS operating in Band II, it applies for 1910 MHz to 1915 MHz, while the rest is covered in sub-clause 9.7.6.3.2.
UTRA FDD Band XXVI or E-UTRA Band 26 or NR band n26	859-894 MHz	-46 dBm	1 MHz	This requirement does not apply to UTRA FDD BS operating in band V or band XXVI
	814-849 MHz	-43 dBm	1 MHz	This requirement does not apply to UTRA FDD BS operating in band XXVI, since it is already covered by the requirements in subclause 9.7.6.3.2 For UTRA FDD BS operating in band V, it applies for 814MHz to 824MHz, while the rest is covered in subclause 9.7.6.3.2
E-UTRA Band 27	852 – 869 MHz	-46 dBm	1 MHz	This requirement does not apply to UTRA BS operating in Band V or XXVI.
	807 – 824 MHz	-43 dBm	1 MHz	For UTRA BS operating in Band XXVI, it applies for 807 MHz to 814 MHz, while the rest is covered in subclause 9.7.6.3.2.
E-UTRA Band 28 or NR band n28	758 – 803 MHz	-46 dBm	1 MHz	
	703 – 748 MHz	-43 dBm	1 MHz	
E-UTRA Band 29 or NR band n29	717 – 728 MHz	-46 dBm	1 MHz	
E-UTRA Band 30 or NR band n30	2350 - 2360 MHz	-46 dBm	1 MHz	
	2305 - 2315 MHz	-43 dBm	1 MHz	
E-UTRA Band 31	462.5 -467.5 MHz	-46 dBm	1 MHz	
	452.5 -457.5 MHz	-43 dBm	1 MHz	
UTRA FDD Band XXXII or E-UTRA Band 32	1452 – 1496 MHz	-46 dBm	1 MHz	This requirement does not apply to UTRA BS operating in Band XI, XXI, or XXXII
UTRA TDD Band a) or E-UTRA Band 33	1900 – 1920 MHz	-46 dBm	1 MHz	
UTRA TDD Band a) or E-UTRA Band 34 or NR band n34	2010 – 2025 MHz	-46 dBm	1 MHz	
UTRA TDD Band b) or E-UTRA Band 35	1850 – 1910 MHz	-46 dBm	1 MHz	
UTRA TDD Band b) or E-UTRA Band 36	1930 – 1990 MHz	-46 dBm	1 MHz	
UTRA TDD Band c) or E-UTRA Band 37	1910 – 1930 MHz	-46 dBm	1 MHz	
UTRA TDD Band d) or E-UTRA Band 38 or NR band n38	2570 – 2620 MHz	-46 dBm	1 MHz	
UTRA TDD Band f) or E-UTRA Band 39 or NR band n39	1880 – 1920 MHz	-46 dBm	1 MHz	Applicable in China
UTRA TDD in Band e) or E-UTRA Band 40 or NR band n40	2300 – 2400 MHz	-46 dBm	1 MHz	
E-UTRA Band 41 or NR band n41	2496 - 2690 MHz	-46 dBm	1 MHz	
E-UTRA Band 42	3400 – 3600 MHz	-46 dBm	1 MHz	

E-UTRA Band 43	3600 – 3800 MHz	-46 dBm	1 MHz	
E-UTRA Band 44	703 - 803 MHz	-46 dBm	1 MHz	
E-UTRA Band 45	1447 - 1467 MHz	-46 dBm	1 MHz	
E-UTRA Band 46 or NR Band n46	5150 - 5925 MHz	-46 dBm	1 MHz	
E-UTRA Band 47	5855 - 5925 MHz	-46 dBm	1 MHz	
E-UTRA Band 48 or NR Band n48	3550 – 3700 MHz	-46 dBm	1 MHz	
E-UTRA Band 49	3550 – 3700 MHz	-52 dBm	1 MHz	
E-UTRA Band 50 or NR band n50	1432 – 1517 MHz	-46 dBm	1 MHz	
E-UTRA Band 51 or NR Band n51	1427 – 1432 MHz	-46 dBm	1 MHz	
E-UTRA Band 52	3300 – 3400 MHz	-52 dBm	1 MHz	
E-UTRA Band 53 or NR Band n53	2483.5 - 2495 MHz	-52 dBm	1 MHz	
E-UTRA Band 65 or NR band n65	2110 - 2200 MHz	-46 dBm	1 MHz	This requirement does not apply to UTRA BS operating in band I,
	1920 - 2010 MHz	-43 dBm	1 MHz	For UTRA BS operating in Band I, it applies for 1980 MHz to 2010 MHz, while the rest is covered in subclause 9.7.6.3.2
E-UTRA Band 66 or NR band n66	2110 - 2200 MHz	-46 dBm	1 MHz	This requirement does not apply to UTRA BS operating in band IV or X .
	1710 - 1780 MHz	-43 dBm	1 MHz	For UTRA BS operating in Band IV, this requirement applies for 1755 MHz to 1780 MHz, while the rest is covered in subclause 9.7.6.3.2. For UTRA BS operating in Band X, this requirement applies for 1770 MHz to 1780 MHz, while the rest is covered in subclause 9.7.6.3.2.
E-UTRA Band 67 or NR band n67	738 - 758 MHz	-46 dBm	1 MHz	
E-UTRA Band 68	753 -783 MHz	-46 dBm	1 MHz	
	698-728 MHz	-43 dBm	1 MHz	
E-UTRA Band 69	2570 - 2620 MHz	-46 dBm	1 MHz	
E-UTRA Band 70 or NR band n70	1995 – 2020 MHz	-46 dBm	1 MHz	This requirement does not apply to UTRA BS operating in band II or XXV.
	1695 – 1710 MHz	-43 dBm	1 MHz	
E-UTRA Band 71	617 - 652 MHz	-52 dBm	1 MHz	
	663 – 698 MHz	-49 dBm	1 MHz	
E-UTRA Band 72	461 - 466 MHz	-52 dBm	1 MHz	
	451 - 456 MHz	-49 dBm	1 MHz	
E-UTRA Band 73	460 - 465 MHz	-52 dBm	1 MHz	
	450 - 455 MHz	-49 dBm	1 MHz	
E-UTRA Band 74 or NR Band n74	1475 – 1518 MHz	-46 dBm	1 MHz	This requirement does not apply to UTRA FDD BS operating in band XI, XXI or XXXII.
	1427 – 1470 MHz	-43 dBm	1MHz	
E-UTRA Band 75 or NR Band n75	1432 - 1517 MHz	-46 dBm	1 MHz	
E-UTRA Band 76 or NR Band n76	1427 - 1432 MHz	-46 dBm	1 MHz	
NR Band n77	3300 MHz – 4200 MHz	-46 dBm	1 MHz	

NR Band n78	3300 MHz – 3800 MHz	-46 dBm	1 MHz	
NR Band n79	4.4 – 5.0 GHz	-46 dBm	1 MHz	
NR Band n80	1710 – 1785 MHz	-43 dBm	1 MHz	
NR Band n81	880 – 915 MHz	-43 dBm	1 MHz	
NR Band n82	832 – 862 MHz	-43 dBm	1 MHz	
NR Band n83	703 – 748 MHz	-43 dBm	1 MHz	
NR Band n84	1920 – 1980 MHz	-43 dBm	1 MHz	
E-UTRA Band 85 or NR band n85	728 - 746 MHz	-46 dBm	1 MHz	
	698 - 716 MHz	-43 dBm	1 MHz	
NR Band n86	1710 – 1780 MHz	-43 dBm	1 MHz	
E-UTRA Band 87	420 - 425 MHz	-52 dBm	1 MHz	
	410 – 415 MHz	-49 dBm	1 MHz	
E-UTRA Band 88	422 - 427 MHz	-52 dBm	1 MHz	
	412 - 417 MHz	-49 dBm	1 MHz	
NR Band n89	824 - 849 MHz	-43 dBm	1 MHz	This requirement does not apply to UTRA FDD BS operating in band V or XXVI, since it is already covered by the requirement in clause 9.7.6.3.2.
NR Band n91	1427 - 1432 MHz	-46 dBm	1 MHz	This requirement does not apply to UTRA FDD BS operating in band XI , XXI or XXXII.
	832 – 862 MHz	-43 dBm	1 MHz	This requirement does not apply to UTRA FDD BS operating in band XX, since it is already covered by the requirement in subclause 9.7.6.3.2.
NR Band n92	1432 - 1517 MHz	-46 dBm	1 MHz	This requirement does not apply to UTRA FDD BS operating in band XI , XXI or XXXII.
	832 – 862 MHz	-43 dBm	1 MHz	This requirement does not apply to UTRA FDD BS operating in band XX, since it is already covered by the requirement in subclause 9.7.6.3.2.
NR Band n93	1427 - 1432 MHz	-46 dBm	1 MHz	This requirement does not apply to UTRA FDD BS operating in band XI , XXI or XXXII.
	880 – 915 MHz	-43 dBm	1 MHz	This requirement does not apply to UTRA FDD BS operating in band VIII, since it is already covered by the requirement in subclause 9.7.6.3.2.
NR Band n94	1432 - 1517 MHz	-46 dBm	1 MHz	This requirement does not apply to UTRA FDD BS operating in band XI , XXI or XXXII.
	880 – 915 MHz	-43 dBm	1 MHz	This requirement does not apply to UTRA FDD BS operating in band VIII, since it is already covered by the requirement in subclause 9.7.6.3.2.
NR band n95	2010 – 2025 MHz	-46 dBm	1 MHz	
NR band n96	5925 – 7125 MHz	-46 dBm	1 MHz	
NR band n97	2300 – 2400 MHz	-46 dBm	1 MHz	
NR band n98	1880 – 1920 MHz	-46 dBm	1 MHz	
NR band n99	1626.5 – 1660.5	-43 dBm	1 MHz	
NR band n102	5925 – 6425 MHz	-46 dBm	1 MHz	
E-UTRA Band 103	757 – 758 MHz	-46 dBm	1 MHz	
	787 – 788 MHz	-43 dBm	1 MHz	
NR band n104	6425 – 7125 MHz	-46 dBm	1 MHz	
NOTE 1: The co-existence requirements do not apply for the 10 MHz frequency range immediately outside the <i>downlink operating band</i> (see subclause 9.7.1). Emission limits for this excluded frequency range may be covered by local or regional requirements.				
NOTE 2: The table above assumes that two operating bands, where the frequency ranges would be overlapping, are not deployed in the same geographical area. For such a case of operation with overlapping frequency arrangements in the same geographical area, special co-existence requirements may apply that are not covered by the 3GPP specifications.				

The following requirement may be applied for the protection of PHS in geographic areas in which both PHS and UTRA FDD are deployed. This requirement is also applicable at specified frequencies falling between 12.5MHz below the first carrier frequency used and 12.5MHz above the last carrier frequency used.

The TRP of any spurious emission shall not exceed:

**Table 9.7.6.3.3-2: AAS BS OTA Spurious emissions limits for BS in geographic coverage area of PHS**

Band	Maximum Level	Measurement Bandwidth	Notes
1884.5 - 1915.7 MHz	-35 dBm	300 kHz	

**Table 9.7.6.3.3-3: Void**

NOTE: This requirement for the frequency range 2610-2615 MHz may be applied to geographic areas in which both UTRA-TDD and UTRA-FDD are deployed.

The following requirement shall be applied to AAS BS operating in Bands XIII and XIV to ensure that appropriate interference protection is provided to 700 MHz public safety operations. This requirement is also applicable at specified frequencies falling between 12.5 MHz below the first carrier frequency used and 12.5 MHz above the last carrier frequency used.

The TRP of any spurious emission shall not exceed:

**Table 9.7.6.3.3-4: AAS BS OTA Spurious emissions limits**

Operating Band	Band	Maximum Level	Measurement Bandwidth	Notes
XIII	763 - 775 MHz	-40 dBm	6.25 kHz	
XIII	793 - 805 MHz	-40 dBm	6.25 kHz	
XIV	769 - 775 MHz	-40 dBm	6.25 kHz	
XIV	799 - 805 MHz	-40 dBm	6.25 kHz	

The following requirement shall be applied to AAS BS operating in Bands XXVI to ensure that appropriate interference protection is provided to 800 MHz public safety operations. This requirement is also applicable at specified frequencies falling between 12.5 MHz below the first carrier frequency used and 12.5 MHz above the last carrier frequency used.

The TRP of any spurious emission shall not exceed:

**Table 9.7.6.3.3-5: AAS BS OTA Spurious emissions limits**

Operating Band	Band	Maximum Level	Measurement Bandwidth	Notes
XXVI	851 - 859 MHz	-7 dBm	100 kHz	Applicable for offsets > 37.5kHz from the channel edge

#### 9.7.6.3.4 Co-location with other base stations

##### 9.7.6.3.4.1 General

These requirements may be applied for the protection of other BS receivers when GSM900, DCS1800, PCS1900, GSM850, CDMA850, UTRA FDD, UTRA TDD, E-UTRA BS and/or NR BS are co-located with a BS.

The requirements assume with base stations of the same class.

NOTE: For co-location with UTRA, the requirements are based on co-location with UTRA FDD or TDD base stations.

The requirements are co-location emission requirements are specified as the power sum of the supported polarization(s) at the *co-location reference* antenna conducted output(s).

#### 9.7.6.3.4.2 Minimum Requirement

The output of the *co-location reference antenna* of any spurious emission shall not exceed the limits of table 9.7.6.3.4.2-1 for a AAS BS where requirements for co-location with a BS type listed in the first column apply, depending on the declared Base Station class. For a *multi-band RIB*, the exclusions and conditions in the Notes column of table 9.7.6.3.4.2-1 apply for each supported operating band.

**Table 9.7.6.3.4.2-1: UTRA AAS BS OTA Spurious emissions limits for AAS BS co-located with another BS**

Type of co-located BS	Frequency range for co-location requirement	Maximum Level (WA-BS)	Maximum Level (MR-BS)	Maximum Level (LA-BS)	Measurement Band width	Notes
GSM900	876-915 MHz	-122 dBm	-115 dBm	-112 dBm	100 kHz	
DCS1800	1710 - 1785 MHz	-122 dBm	-115 dBm	-112 dBm	100 kHz	
PCS1900	1850 - 1910 MHz	-122 dBm	-115 dBm	-112 dBm	100 kHz	
GSM850 or CDMA850	824 - 849 MHz	-122 dBm	-115 dBm	-112 dBm	100 kHz	
UTRA FDD Band I or E-UTRA Band 1 or NR band n1	1920 - 1980 MHz	-120 dBm	-115 dBm	-112 dBm	100 kHz	
UTRA FDD Band II or E-UTRA Band 2 or NR band n2	1850 - 1910 MHz	-120 dBm	-115 dBm	-112 dBm	100 kHz	
UTRA FDD Band III or E-UTRA Band 3 or NR band n3	1710 - 1785 MHz	-120 dBm	-115 dBm	-112 dBm	100 kHz	
UTRA FDD Band IV or E-UTRA Band 4	1710 - 1755 MHz	-120 dBm	-115 dBm	-112 dBm	100 kHz	
UTRA FDD Band V or E-UTRA Band 5 or NR band n5	824 - 849 MHz	-120 dBm	-115 dBm	-112 dBm	100 kHz	
UTRA FDD Band VI, XIX or E-UTRA Band 6, 19	830 - 845 MHz	-120 dBm	-115 dBm	-112 dBm	100 kHz	
UTRA FDD Band VII or E-UTRA Band 7 or NR band n7	2500 - 2570 MHz	-120 dBm	-115 dBm	-112 dBm	100 kHz	
UTRA FDD Band VIII or E-UTRA Band 8 or NR band n8	880 - 915 MHz	-120 dBm	-115 dBm	-112 dBm	100 kHz	
UTRA FDD Band IX or E-UTRA Band 9	1749.9 - 1784.9 MHz	-120 dBm	-115 dBm	-112 dBm	100 kHz	
UTRA FDD Band X or E-UTRA Band 10	1710 - 1770 MHz	-120 dBm	-115 dBm	-112 dBm	100 kHz	
UTRA FDD Band XI or E-UTRA Band 11	1427.9 - 1447.9 MHz	-120 dBm	-115 dBm	-112 dBm	100 kHz	

UTRA FDD Band XII or E-UTRA Band 12 or NR band n12	699 - 716 MHz	-120 dBm	-115 dBm	-112 dBm	100 kHz	
UTRA FDD Band XIII or E-UTRA Band 13 or NR band n13	777 - 787 MHz	-120 dBm	-115 dBm	-112 dBm	100 kHz	
UTRA FDD Band XIV or E-UTRA Band 14 or NR band n14	788 - 798 MHz	-120 dBm	-115 dBm	-112 dBm	100 kHz	
E-UTRA Band 17	704 - 716 MHz	-120 dBm	-115 dBm	-112 dBm	100 kHz	
E-UTRA Band 18 or NR Band n18	815 - 830 MHz	-120 dBm	-115 dBm	-112 dBm	100 kHz	
UTRA FDD Band XX or E-UTRA Band 20 or NR band n20	832 - 862 MHz	-120 dBm	-115 dBm	-112 dBm	100 kHz	
UTRA FDD Band XXI or E-UTRA Band 21	1447.9 – 1462.9 MHz	-120 dBm	-115 dBm	-112 dBm	100 kHz	
UTRA FDD Band XXII or E-UTRA Band 22	3410 – 3490 MHz	-120 dBm	-115 dBm	-112 dBm	100 kHz	This is not applicable to BS operating in Band 42
E-UTRA Band 24 or NR band n24	1626.5 – 1660.5 MHz	-120 dBm	-115 dBm	-112 dBm	100 kHz	
UTRA FDD Band XXV or E-UTRA Band 25 or NR band n25	1850 - 1915 MHz	-120 dBm	-115 dBm	-112 dBm	100 kHz	
UTRA FDD Band XXVI or E-UTRA Band 26 or NR band n26	814 - 849 MHz	-120 dBm	-115 dBm	-112 dBm	100 kHz	
E-UTRA Band 27	807 - 824 MHz	-120 dBm	-115 dBm	-112 dBm	100 kHz	
E-UTRA Band 28 or NR band n28	703 – 748 MHz	-120 dBm	-115 dBm	-112 dBm	100 kHz	This is not applicable to BS operating in Band 44
E-UTRA Band 30 or NR band n30	2305 - 2315 MHz	-120 dBm	-115 dBm	-112 dBm	100 kHz	This is not applicable to BS operating in Band 40
E-UTRA Band 31	452.5 – 457.5 MHz	-120 dBm	-115 dBm	-112 dBm	100 kHz	

UTRA TDD Band a) or E-UTRA Band 33	1900 - 1920 MHz	-120 dBm	-115 dBm	-112 dBm	100 kHz	This is not applicable to BS operating in Band 33
UTRA TDD Band a) or E-UTRA Band 34 or NR band n34	2010 - 2025 MHz	-120 dBm	-115 dBm	-112 dBm	100 kHz	This is not applicable to BS operating in Band 34
UTRA TDD Band b) or E-UTRA Band 35	1850 – 1910 MHz	-120 dBm	-115 dBm	-112 dBm	100 kHz	This is not applicable to BS operating in Band 35
UTRA TDD Band b) or E-UTRA Band 36	1930 - 1990 MHz	-120 dBm	-115 dBm	-112 dBm	100 kHz	This is not applicable to BS operating in Band 2 and 36
UTRA TDD Band c) or E-UTRA Band 37	1910 - 1930 MHz	-120 dBm	-115 dBm	-112 dBm	100 kHz	This is not applicable to BS operating in Band 37. This unpaired band is defined in ITU-R M.1036, but is pending any future deployment.
UTRA TDD Band d) or E-UTRA Band 38 or NR band n38	2570 – 2620 MHz	-120 dBm	-115 dBm	-112 dBm	100 kHz	This is not applicable to BS operating in Band 38.
UTRA TDD Band f) or E-UTRA Band 39 or NR band n39	1880 – 1920MHz	-120 dBm	-115 dBm	-112 dBm	100 kHz	This is not applicable to BS operating in Band 33 and 39
UTRA TDD Band e) or E-UTRA Band 40 or NR band n40	2300 – 2400MHz	-120 dBm	-115 dBm	-112 dBm	100 kHz	This is not applicable to BS operating in Band 30 or 40
E-UTRA Band 41 or NR band n41	2496 – 2690MHz	-120 dBm	-115 dBm	-112 dBm	100 kHz	This is not applicable to BS operating in Band 41 or 53
E-UTRA Band 42	3400 – 3600 MHz	-120 dBm	-115 dBm	-112 dBm	100 kHz	This is not applicable to BS operating in Band 22, 42 or 43
E-UTRA Band 43	3600 – 3800 MHz	-120 dBm	-115 dBm	-112 dBm	100 kHz	This is not applicable to BS operating in Band 42 or 43
E-UTRA Band 44	703 – 803 MHz	-120 dBm	-115 dBm	-112 dBm	100 kHz	This is not applicable to BS operating in Band 28 or 44
E-UTRA Band 45	1447 – 1467 MHz	-120 dBm	-115 dBm	-112 dBm	100 kHz	This is not applicable to BS operating in Band 45
E-UTRA Band 46 or NR Band n46	5150 – 5925 MHz	N/A	-115 dBm	-112 dBm	100 kHz	
E-UTRA Band 48 or NR Band n48	3550 – 3700 MHz	-120 dBm	-115 dBm	-112 dBm	100 kHz	
E-UTRA Band 49	3550 – 3700 MHz	N/A	N/A	-112 dBm	100 kHz	

E-UTRA Band 50 or NR band n50	1432 – 1517 MHz	-120 dBm	-115 dBm	-112 dBm	100 kHz	
E-UTRA Band 51 or NR Band n51	1427 – 1432 MHz	N/A	N/A	-112 dBm	100 kHz	
E-UTRA Band 52	3300 – 3400 MHz	-120 dBm	-115 dBm	-112 dBm	100 kHz	
E-UTRA Band 53 or NR Band n53	2483.5 – 2495 MHz	N/A	-115 dBm	-112 dBm	100 kHz	This is not applicable to BS operating in Band 41 or 53
E-UTRA Band 65 or NR band n65	1920 - 2010 MHz	-120 dBm	-115 dBm	-112 dBm	100 kHz	
E-UTRA Band 66 or NR band n66	1710 – 1780 MHz	-120 dBm	-115 dBm	-112 dBm	100 kHz	
E-UTRA Band 68	698 – 728 MHz	-120 dBm	-115 dBm	-112 dBm	100 kHz	
E-UTRA Band 70 or NR band n70	1695 – 1710 MHz	-120 dBm	-115 dBm	-112 dBm	100 kHz	
E-UTRA Band 71 or NR Band n71	663 – 698 MHz	-120 dBm	-115 dBm	-112 dBm	100 kHz	
E-UTRA Band 72	451 – 456 MHz	-120 dBm	-115 dBm	-112 dBm	100 kHz	
E-UTRA Band 73	450 – 455 MHz	-120 dBm	-115 dBm	-112 dBm	100 kHz	
E-UTRA Band 74 or NR band n74	1427 – 1470 MHz	-120 dBm	-115 dBm	-112 dBm	100 kHz	
NR Band n77	3300 MHz – 4200 MHz	-120 dBm	-115 dBm	-112 dBm	100 kHz	
NR Band n78	3300 MHz – 3800 MHz	-120 dBm	-115 dBm	-112 dBm	100 kHz	
NR Band n79	4.4 – 5.0 GHz	-120 dBm	-115 dBm	-112 dBm	100 kHz	
NR Band n80	1710 – 1785 MHz	-120 dBm	-115 dBm	-112 dBm	100 kHz	
NR Band n81	880 – 915 MHz	-120 dBm	-115 dBm	-112 dBm	100 kHz	
NR Band n82	832 – 862 MHz	-120 dBm	-115 dBm	-112 dBm	100 kHz	
NR Band n83	703 – 748 MHz	-120 dBm	-115 dBm	-112 dBm	100 kHz	
NR Band n84	1920 – 1980 MHz	-120 dBm	-115 dBm	-112 dBm	100 kHz	
E-UTRA Band 85 or NR band n85	698 - 716 MHz	-120 dBm	-115 dBm	-112 dBm	100 kHz	
NR Band n86	1710 – 1780 MHz	-120 dBm	-115 dBm	-112 dBm	100 kHz	
E-UTRA Band 87	410 – 415 MHz	-120 dBm	-115 dBm	-112 dBm	100 kHz	

E-UTRA Band 88	412 – 417 MHz	-120 dBm	-115 dBm	-112 dBm	100 kHz	
NR band n89	824 - 849 MHz	-120 dBm	-115 dBm	-112 dBm	100 kHz	
NR band n91	832 – 862 MHz	N/A	N/A	-112 dBm	100 kHz	
NR band n92	832 – 862 MHz	-120 dBm	-115 dBm	-112 dBm	100 kHz	
NR band n93	880 – 915 MHz	N/A	N/A	-112 dBm	100 kHz	
NR band n94	880 – 915 MHz	-120 dBm	-115 dBm	-112 dBm	100 kHz	
NR band n95	2010 - 2025 MHz	-120 dBm	-115 dBm	-112 dBm	100 kHz	
NR band n96	5925 - 7125 MHz	N/A	-114 dBm	-111 dBm	100 kHz	
NR band n97	2300 – 2400MHz	-120 dBm	-115 dBm	-112 dBm	100 kHz	
NR band n98	1880 – 1920MHz	-120 dBm	-115 dBm	-112 dBm	100 kHz	
NR band n99	1626.5 – 1660.5 MHz	-120 dBm	-115 dBm	-112 dBm	100 kHz	
NR band n102	5925 -6425 MHz	N/A	-114 dBm	-111 dBm	100 kHz	
E-UTRA Band 103	787 – 788 MHz	-120 dBm	-115 dBm	-112 dBm	100 kHz	
NR band n104	6425 – 7125 MHz	-119 dBm	-114 dBm	-111 dBm	100k Hz	

NOTE 1: As defined in the scope for spurious emissions in this subclause, the co-location requirements in table 9.7.6.3.4.2-1 do not apply for the 10 MHz frequency range immediately outside the BS transmit frequency range of a *downlink operating band* (see subclause 9.7.1). The current state-of-the-art technology does not allow a single generic solution for co-location with other system on adjacent frequencies for 30 dB BS-BS minimum coupling loss. However, there are certain site-engineering solutions that can be used. These techniques are addressed in TR 25.942 [12].

NOTE 2: Table 9.7.6.3.4.2-1 assumes that two operating bands, where the corresponding BS transmit and receive frequency ranges in subclause 9.7.1 would be overlapping, are not deployed in the same geographical area. For such a case of operation with overlapping frequency arrangements in the same geographical area, special co-location requirements may apply that are not covered by the 3GPP specifications.

NOTE 3: Co-located TDD base stations that are synchronized and using the same or adjacent operating band can transmit without special co-locations requirements. For unsynchronized base stations, special co-location requirements may apply that are not covered by the 3GPP specifications.

## 9.7.6.4 Minimum requirement for single RAT E-UTRA operation

### 9.7.6.4.1 Mandatory Requirements

#### 9.7.6.4.1.1 Minimum requirement (Category A)

The minimum requirement for single RAT E-UTRA BS is the same as that defined for an MSR BS in subclause 9.7.6.2.1.1.

## 9.7.6.4.1.2 Minimum Requirement (Category B)

The TRP of any spurious emission shall not exceed the limits in table 9.7.6.4.1.2-1

**Table 9.7.6.4.1.2-1: AAS BS OTA Spurious emissions limits, Category B**

Frequency range	Maximum Level (Note 4)	Measurement Bandwidth	Notes
30 MHz ↔ 1 GHz	-36 + X dBm	100 kHz	NOTE 1
1 GHz ↔ 12.75 GHz	-30 + X dBm	1 MHz	NOTE 2
12.75 GHz ↔ 5 <sup>th</sup> harmonic of the upper frequency edge of the DL operating band in GHz	-30 + X dBm	1 MHz	NOTE 2, NOTE 3
NOTE 1: Bandwidth as in ITU-R SM.329 [14], s4.1			
NOTE 2: Bandwidth as in ITU-R SM.329 [14], s4.1. Upper frequency as in ITU-R SM.329 [14], s2.5 table 1			
NOTE 3: Applies only for Bands 22, 42, 43 and 48.			
NOTE 4: X = 9 dB, unless stated differently in regional regulation.			

## 9.7.6.4.2 Protection of the BS receiver of own or different BS

This requirement shall be applied for E-UTRA FDD operation in order to prevent the receivers of own or a different BS of the same band being desensitised by emissions from a *OTA AAS BS*.

The requirement is a co-location requirement. The power levels are specified at the *co-location reference antenna* output.

The power sum of any spurious emission is specified over all supported polarizations of the *co-location reference antenna* and shall not exceed the limits in table 9.7.6.4.2-1.

**Table 9.7.6.4.2-1: BS Spurious emissions limits for protection of the BS receiver**

	Frequency range	Maximum Level	Measurement Bandwidth	Notes
Wide Area BS	$F_{UL\_low} - F_{UL\_high}$	- 117 dBm	100 kHz	
Medium Range BS	$F_{UL\_low} - F_{UL\_high}$	- 112 dBm	100 kHz	
Local Area BS	$F_{UL\_low} - F_{UL\_high}$	-109 dBm	100 kHz	
NOTE 1: For BS operating in regions where a band is only partially allocated for E-UTRA operations (e.g. band 28), this requirement only applies in the UL frequency range of the partial allocation.				
NOTE 2: For BS capable of multi-band operation, Table 9.7.6.4.2-1 assumes that the supported <i>operating bands</i> , where the corresponding BS transmit and receive frequency ranges in TS 37.104 [5] Table 4.5-1 or Table 4.5-2 would be overlapping, are not deployed in the same geographical area. For such a case of operation with overlapping frequency arrangements in the same geographical area, special protection requirements may apply that are not covered by the 3GPP specifications.				

## 9.7.6.4.3 Additional spurious emissions requirements

## 9.7.6.4.3.1 General

These requirements may be applied for the protection of system operating in frequency ranges other than the BS *downlink operating band*. The limits may apply as an optional protection of such systems that are deployed in the same geographical area as the BS, or they may be set by local or regional regulation as a mandatory requirement for an operating band. It is in some cases not stated in the present document whether a requirement is mandatory or under what exact circumstances that a limit applies, since this is set by local or regional regulation. An overview of regional requirements in the present document is given in subclause 4.5.

Some requirements may apply for the protection of specific equipment (UE, MS and/or BS) or equipment operating in specific systems (GSM/EDGE, CDMA, UTRA, E-UTRA, NR, etc.) as listed below.

All additional spurious requirements are TRP unless otherwise stated.

#### 9.7.6.4.3.2 Minimum Requirement

The TRP of any spurious emission shall not exceed the limits of table 9.7.6.4.3.2-1 for an AAS BS where requirements for co-existence with the system listed in the first column apply. For a *multi-band RIB*, the exclusions and conditions in the notes column of table 9.7.6.4.3.2-1 apply for each supported operating band.

**Table 9.7.6.4.3.2-1: AAS BS OTA Spurious emissions limits for co-existence with systems operating in other frequency bands**

System type to co-exist with	Frequency range for co-existence requirement	Maximum Level	Measurement Bandwidth	Note
GSM900	921 - 960 MHz	-48 dBm	100 kHz	This requirement does not apply to BS operating in band 8
	876 - 915 MHz	-52 dBm	100 kHz	For the frequency range 880-915 MHz, this requirement does not apply to BS operating in band 8, since it is already covered by the requirement in subclause 9.7.6.4.2
DCS1800 (NOTE 3)	1805 - 1880 MHz	-38 dBm	100 kHz	This requirement does not apply to BS operating in band 3.
	1710 - 1785 MHz	-52 dBm	100 kHz	This requirement does not apply to BS operating in band 3, since it is already covered by the requirement in subclause 9.7.6.4.2.
PCS1900	1930 - 1990 MHz	-38 dBm	100 kHz	This requirement does not apply to BS operating in band 2, 25, band 36 or band 70.
	1850 - 1910 MHz	-52 dBm	100 kHz	This requirement does not apply to BS operating in band 2 or 25, since it is already covered by the requirement in subclause 9.7.6.4.2. This requirement does not apply to BS operating in band 35.
GSM850 or CDMA850	869 - 894 MHz	-48 dBm	100 kHz	This requirement does not apply to BS operating in band 5 or 26. This requirement applies to E-UTRA BS operating in Band 27 for the frequency range 879-894 MHz.
	824 - 849 MHz	-52 dBm	100 kHz	This requirement does not apply to BS operating in band 5 or 26, since it is already covered by the requirement in subclause 9.7.6.4.2. For BS operating in Band 27, it applies 3 MHz below the <i>Band 27 downlink operating band</i> .
UTRA FDD Band I or E-UTRA Band 1 or NR band n1	2110 - 2170 MHz	-43 dBm	1 MHz	This requirement does not apply to BS operating in band 1 or 65/n65.
	1920 - 1980 MHz	-40 dBm	1 MHz	This requirement does not apply to BS operating in band 1 or 65/n65, since it is already covered by the requirement in subclause 9.7.6.4.2.
UTRA FDD Band II or E-UTRA Band 2 or NR band n2	1930 - 1990 MHz	-43 dBm	1 MHz	This requirement does not apply to BS operating in band 2, 25 or 70.
	1850 - 1910 MHz	-40 dBm	1 MHz	This requirement does not apply to BS operating in band 2 or 25, since it is already covered by the requirement in subclause 9.7.6.4.2
UTRA FDD Band III or E-UTRA Band 3 or NR band n3 (NOTE 3)	1805 - 1880 MHz	-43 dBm	1 MHz	This requirement does not apply to BS operating in band 3 or 9.
	1710 - 1785 MHz	-40 dBm	1 MHz	This requirement does not apply to BS operating in band 3, since it is already covered by the requirement in subclause 9.7.6.4.2. For BS operating in band 9, it applies for 1710 MHz to 1749.9 MHz and 1784.9 MHz to 1785 MHz, while the rest is covered in subclause 9.7.6.4.2.
UTRA FDD Band IV or E-UTRA Band 4	2110 - 2155 MHz	-43 dBm	1 MHz	This requirement does not apply to BS operating in band 4, 10 or 66
	1710 - 1755 MHz	-40 dBm	1 MHz	This requirement does not apply to BS operating in band 4, 10 or 66, since it is already covered by the requirement in subclause 9.7.6.4.2.
UTRA FDD Band V or E-UTRA Band 5 or NR band n5	869 - 894 MHz	-43 dBm	1 MHz	This requirement does not apply to BS operating in band 5 or 26. This requirement applies to E-UTRA BS operating in Band 27 for the frequency range 879-894 MHz.
	824 - 849 MHz	-40 dBm	1 MHz	This requirement does not apply to BS operating in band 5 or 26, since it is already covered by the requirement in subclause 9.7.6.4.2. For BS operating in Band 27, it applies 3 MHz below the <i>Band 27 downlink operating band</i> .
	860 - 890 MHz	-43 dBm	1 MHz	This requirement does not apply to BS operating in band 6, 18, 19
	815 - 830 MHz	-40 dBm	1 MHz	This requirement does not apply to BS operating in band 18 since it is already covered by the requirement in subclause 9.7.6.4.2.

UTRA FDD Band VI, XIX or E-UTRA Band 6, 18, 19	830 - 845 MHz	-40 dBm	1 MHz	This requirement does not apply to BS operating in band 6, 19, since it is already covered by the requirement in subclause 9.7.6.4.2.
UTRA FDD Band VII or E-UTRA Band 7 or NR band n7	2620 - 2690 MHz	-43 dBm	1 MHz	This requirement does not apply to BS operating in band 7.
	2500 - 2570 MHz	-40 dBm	1 MHz	This requirement does not apply to BS operating in band 7, since it is already covered by the requirement in subclause 9.7.6.4.2.
UTRA FDD Band VIII or E-UTRA Band 8 or NR band n8	925 - 960 MHz	-43 dBm	1 MHz	This requirement does not apply to BS operating in band 8.
	880 - 915 MHz	-40 dBm	1 MHz	This requirement does not apply to BS operating in band 8, since it is already covered by the requirement in subclause 9.7.6.4.2.
UTRA FDD Band IX or E-UTRA Band 9	1844.9 - 1879.9 MHz	-43 dBm	1 MHz	This requirement does not apply to BS operating in band 3 or 9.
	1749.9 - 1784.9 MHz	-40 dBm	1 MHz	This requirement does not apply to BS operating in band 3 or 9, since it is already covered by the requirement in subclause 9.7.6.4.2.
UTRA FDD Band X or E-UTRA Band 10	2110 - 2170 MHz	-43 dBm	1 MHz	This requirement does not apply to BS operating in band 4, 10 or 66
	1710 - 1770 MHz	-40 dBm	1 MHz	This requirement does not apply to BS operating in band 10 or 66, since it is already covered by the requirement in subclause 9.7.6.4.2. For BS operating in Band 4, it applies for 1755 MHz to 1770 MHz, while the rest is covered in subclause 9.7.6.4.2.
UTRA FDD Band XI or XXI or E-UTRA Band 11 or 21	1475.9 - 1510.9 MHz	-43 dBm	1 MHz	This requirement does not apply to BS operating in band 11, 21, 32, 50, 74, 75
	1427.9 - 1447.9 MHz	-40 dBm	1 MHz	This requirement does not apply to BS operating in band 11 or 74, since it is already covered by the requirement in subclause 9.7.6.4.2. This requirement does not apply to BS operating in band 32, 50, 51, 75 or 76.
	1447.9 – 1462.9 MHz	-40 dBm	1 MHz	This requirement does not apply to BS operating in band 21 or 74, since it is already covered by the requirement in subclause 9.7.6.4.2. This requirement does not apply to BS operating in band 32, 50 or 75.
UTRA FDD Band XII or E-UTRA Band 12 or NR band n12	729 - 746 MHz	-43 dBm	1 MHz	This requirement does not apply to BS operating in band 12 or 85.
	699 - 716 MHz	-40 dBm	1 MHz	This requirement does not apply to BS operating in band 12 or 85, since it is already covered by the requirement in subclause 9.7.6.4.2. For BS operating in Band 29, it applies 1 MHz below the <i>Band 29 downlink operating band (NOTE 7)</i>
UTRA FDD Band XIII or E-UTRA Band 13 or NR band n13	746 - 756 MHz	-43 dBm	1 MHz	This requirement does not apply to BS operating in band 13.
	777 - 787 MHz	-40 dBm	1 MHz	This requirement does not apply to BS operating in band 13, since it is already covered by the requirement in subclause 9.7.6.4.2.
UTRA FDD Band XIV or E-UTRA Band 14	758 - 768 MHz	-43 dBm	1 MHz	This requirement does not apply to BS operating in band 14.
	788 - 798 MHz	-40 dBm	1 MHz	This requirement does not apply to BS operating in band 14, since it is already covered by the requirement in subclause 9.7.6.4.2.
E-UTRA Band 17	734 - 746 MHz	-43 dBm	1 MHz	This requirement does not apply to BS operating in band 17.
	704 - 716 MHz	-40 dBm	1 MHz	This requirement does not apply to BS operating in band 17, since it is already covered by the requirement in subclause 9.7.6.4.2. For BS operating in Band 29, it applies 1 MHz below the <i>Band 29 downlink operating band (NOTE 7)</i>
	791 - 821 MHz	-43 dBm	1 MHz	This requirement does not apply to BS operating in band 20 or 28.

UTRA FDD Band XX or E-UTRA Band 20 or NR band n20	832 - 862 MHz	-40 dBm	1 MHz	This requirement does not apply to BS operating in band 20, since it is already covered by the requirement in subclause 9.7.6.4.2.
UTRA FDD Band XXII or E-UTRA Band 22	3510 – 3590 MHz	-43 dBm	1 MHz	This requirement does not apply to BS operating in band 22, 42, 48, 49, 77 or 78.
	3410 – 3490 MHz	-40 dBm	1 MHz	This requirement does not apply to BS operating in band 22, since it is already covered by the requirement in subclause 9.7.3.3. This requirement does not apply to Band 42, 77 or 78.
E-UTRA Band 24 or NR band n24	1525 – 1559 MHz	-43 dBm	1 MHz	This requirement does not apply to BS operating in band 24.
	1626.5 – 1660.5 MHz	-40 dBm	1 MHz	This requirement does not apply to BS operating in band 24, since it is already covered by the requirement in subclause 9.7.6.4.2.
UTRA FDD Band XXV or E-UTRA Band 25 or NR band n25	1930 - 1995 MHz	-43 dBm	1 MHz	This requirement does not apply to BS operating in band 2, 25 or 70.
	1850 - 1915 MHz	-40 dBm	1 MHz	This requirement does not apply to BS operating in band 25, since it is already covered by the requirement in subclause 9.7.6.4.2. For BS operating in Band 2, it applies for 1910 MHz to 1915 MHz, while the rest is covered in subclause 9.7.6.4.2.
UTRA FDD Band XXVI or E-UTRA Band 26 or NR band n26	859 - 894 MHz	-43 dBm	1 MHz	This requirement does not apply to BS operating in band 5 or 26. This requirement applies to E-UTRA BS operating in Band 27 for the frequency range 879-894 MHz.
	814 - 849 MHz	-40 dBm	1 MHz	This requirement does not apply to BS operating in band 26, since it is already covered by the requirement in subclause 9.7.6.4.2. For BS operating in Band 5, it applies for 814 MHz to 824 MHz, while the rest is covered in subclause 9.7.6.4.2. For BS operating in Band 27, it applies 3 MHz below the Band 27 <i>downlink operating band</i> .
E-UTRA Band 27	852 – 869 MHz	-43 dBm	1 MHz	This requirement does not apply to BS operating in bands 5, 26 or 27.
	807 – 824 MHz	-40 dBm	1 MHz	This requirement does not apply to BS operating in band 27, since it is already covered by the requirement in subclause 9.7.6.4.2. For BS operating in Band 26, it applies for 807 MHz to 814 MHz, while the rest is covered in subclause 9.7.6.4.2. This requirement also applies to BS operating in Band 28, starting 4 MHz above the Band 28 <i>downlink operating band</i> (NOTE 6).
E-UTRA Band 28 or NR band n28	758 - 803 MHz	-43 dBm	1 MHz	This requirement does not apply to BS operating in band 20, 28, 44, 67 or 68.
	703 - 748 MHz	-40 dBm	1 MHz	This requirement does not apply to BS operating in band 28, since it is already covered by the requirement in subclause 9.7.6.4.2. This requirement does not apply to BS operating in Band 44. For BS operating in Band 67, it applies for 703-736MHz. For E-UTRA BS operating in Band 68, it applies for 728MHz to 733MHz.
E-UTRA Band 29 or NR Band n29	717 – 728 MHz	-43 dBm	1 MHz	This requirement does not apply to BS operating in Band 29 or 85
	2350 - 2360 MHz	-43 dBm	1 MHz	This requirement does not apply to BS operating in band 30 or 40.

E-UTRA Band 30 or NR Band n30	2305 - 2315 MHz	-40 dBm	1 MHz	This requirement does not apply to BS operating in band 30, since it is already covered by the requirement in subclause 9.7.6.4.2. This requirement does not apply to BS operating in Band 40.
E-UTRA Band 31	462.5 – 467.5 MHz	-43 dBm	1 MHz	This requirement does not apply to BS operating in band 31, 72, 73.
	452.5 – 457.5 MHz	-40 dBm	1 MHz	This requirement does not apply to BS operating in band 31, since it is already covered by the requirement in subclause 9.7.6.4.2. This requirement does not apply to BS operating in band 72, 73.
UTRA FDD Band XXXII or E-UTRA Band 32	1452 - 1496 MHz	-43 dBm	1 MHz	This requirement does not apply to BS operating in band 11, 21, 32, 50, 74 or 75.
UTRA TDD Band a) or E-UTRA Band 33	1900 - 1920 MHz	-43 dBm	1 MHz	This requirement does not apply to BS operating in Band 33
UTRA TDD Band a) or E-UTRA Band 34 or NR band n34	2010 - 2025 MHz	-43 dBm	1 MHz	This requirement does not apply to BS operating in Band 34
UTRA TDD Band b) or E-UTRA Band 35	1850 – 1910 MHz	-43 dBm	1 MHz	This requirement does not apply to BS operating in Band 35
UTRA TDD Band b) or E-UTRA Band 36	1930 - 1990 MHz	-43 dBm	1 MHz	This requirement does not apply to BS operating in Band 2, 25 or 36
UTRA TDD Band c) or E-UTRA Band 37	1910 - 1930 MHz	-43 dBm	1 MHz	This is not applicable to BS operating in Band 37. This unpaired band is defined in ITU-R M.1036, but is pending any future deployment.
UTRA TDD Band d) or E-UTRA Band 38 or NR band n38	2570 – 2620 MHz	-43 dBm	1 MHz	This requirement does not apply to BS operating in Band 38 or 69.
UTRA TDD Band f) or E-UTRA Band 39 or NR band n39	1880 – 1920MHz	-43 dBm	1 MHz	This is not applicable to BS operating in Band 39
UTRA TDD Band e) or E-UTRA Band 40 or NR band n40	2300 – 2400MHz	-43 dBm	1 MHz	This is not applicable to BS operating in Band 30 or 40
E-UTRA Band 41 or NR band n41	2496 – 2690MHz	-43 dBm	1 MHz	This is not applicable to BS operating in Band 41 or 53
E-UTRA Band 42	3400 – 3600 MHz	-43 dBm	1 MHz	This is not applicable to BS operating in Band 22, 42, 43, 48, 52
E-UTRA Band 43	3600 – 3800 MHz	-43 dBm	1 MHz	This is not applicable to BS operating in Band 42, 43, 48
E-UTRA Band 44	703 - 803 MHz	-43 dBm	1 MHz	This is not applicable to BS operating in Band 28 or 44
E-UTRA Band 45	1447 - 1467 MHz	-43 dBm	1 MHz	This is not applicable to BS operating in Band 45

E-UTRA Band 46 or NR Band n46	5150 - 5925 MHz	-43 dBm	1 MHz	
E-UTRA Band 47	5855 - 5925 MHz	-43 dBm	1 MHz	
E-UTRA Band 48 or NR Band n48	3550 - 3700 MHz	-43 dBm	1 MHz	This is not applicable to BS operating in Band 22, 42, 43, 48
E-UTRA Band 49	3550 - 3700 MHz	-43 dBm	1 MHz	This is not applicable to BS operating in Band 22, 42, 43, 48
E-UTRA Band 50 or NR band n50	1432 - 1517 MHz	-43 dBm	1 MHz	This requirement does not apply to BS operating in Band 11, 21, 32, 45, 50, 51, 74, 75, 76.
E-UTRA Band 51 or NR Band n51	1427 - 1432 MHz	-43 dBm	1 MHz	This requirement does not apply to BS operating in Band 50, 51, 75, 76.
E-UTRA Band 52	3300 - 3400 MHz	-52 dBm	1 MHz	This is not applicable to E-UTRA BS operating in Band 42 or 52.
E-UTRA Band 53 or NR Band n53	2483.5 - 2495 MHz	-52 dBm	1 MHz	This is not applicable to E-UTRA BS operating in Band 41 or 53.
E-UTRA Band 65 or NR band n65	2110 - 2200 MHz	-43 dBm	1 MHz	This requirement does not apply to BS operating in band 1 or 65/n65.
	1920 - 2010 MHz	-40 dBm	1 MHz	This requirement does not apply to BS operating in band 65/n65, since it is already covered by the requirement in subclause 9.7.6.4.2. For BS operating in Band 1, it applies for 1980 MHz to 2010 MHz, while the rest is covered in subclause 9.7.6.4.2.
E-UTRA Band 66 or NR band n66	2110 - 2200 MHz	-43 dBm	1 MHz	This requirement does not apply to BS operating in band 4, 10, 23 or 66.
	1710 - 1780 MHz	-40 dBm	1 MHz	This requirement does not apply to BS operating in band 66, since it is already covered by the requirement in subclause 9.7.6.4.2. For BS operating in Band 4, it applies for 1755 MHz to 1780 MHz, while the rest is covered in subclause 9.7.6.4.2. For BS operating in Band 10, it applies for 1770 MHz to 1780 MHz, while the rest is covered in subclause 9.7.6.4.2.
E-UTRA Band 67 or NR band n67	738 – 758 MHz	-43 dBm	1 MHz	This requirement does not apply to BS operating in band 28 or 67.
E-UTRA Band 68	753 - 783 MHz	-43 dBm	1 MHz	This requirement does not apply to E-UTRA BS operating in band 28, or 68.
	698-728 MHz	-40 dBm	1 MHz	This requirement does not apply to E-UTRA BS operating in band 68, since it is already covered by the requirement in subclause 9.7.3.3. For E-UTRA BS operating in Band 28, it applies between 698 MHz and 703 MHz, while the rest is covered in subclause 9.7.3.3.
E-UTRA Band 69	2570 - 2620 MHz	-43 dBm	1 MHz	This requirement does not apply to E-UTRA BS operating in Band 38 or 69.
E-UTRA Band 70 or NR band n70	1995 - 2020 MHz	-43 dBm	1 MHz	This requirement does not apply to E-UTRA BS operating in band 2, 25 or 70
	1695 – 1710 MHz	-40 dBm	1 MHz	This requirement does not apply to E-UTRA BS operating in band 70, since it is already covered by the requirement in subclause 9.7.6.4.2
E-UTRA Band 71 or NR Band n71	617 – 652 MHz	-43 dBm	1 MHz	This requirement does not apply to BS operating in band 71
	663 – 698 MHz	-40 dBm	1 MHz	This requirement does not apply to BS operating in band 71, since it is already covered by the requirement in sub-clause 6.6.1.2

E-UTRA Band 72	461 - 466 MHz	-43 dBm	1 MHz	This requirement does not apply to BS operating in band 31, 72 or 73.
	451 - 456 MHz	-40 dBm	1 MHz	This requirement does not apply to BS operating in band 72, since it is already covered by the requirement in sub-clause 6.6.1.2. This requirement does not apply to BS operating in band 73.
E-UTRA Band 73	460 - 465 MHz	-43 dBm	1 MHz	This requirement does not apply to BS operating in band 31, 72 or 73.
	450 - 455 MHz	-40 dBm	1 MHz	This requirement does not apply to BS operating in band 73, since it is already covered by the requirement in sub-clause 6.6.1.2.
E-UTRA Band 74 or NR band n74	1475 – 1518 MHz	-43 dBm	1 MHz	This requirement does not apply to BS operating in band 11, 21, 32, 50, 74, 75.
	1427 – 1470 MHz	-40 dBm	1MHz	This requirement does not apply to BS operating in Band 74, since it is already covered by the requirement in sub-clause 6.6.1.2. This requirement does not apply to BS operating in band 32, 45, 50, 51, 75, 76.
E-UTRA Band 75 or NR Band n75	1432 - 1517 MHz	-43 dBm	1 MHz	This requirement does not apply to BS operating in Band 11, 21, 32, 45, 50, 51, 74, 75, 76.
E-UTRA Band 76 or NR Band n76	1427 - 1432 MHz	-43 dBm	1 MHz	This requirement does not apply to BS operating in Band 50, 51, 75, 76.
NR Band n77	3300 MHz – 4200 MHz	-43 dBm	1 MHz	This is not applicable to BS operating in Band 22, 42, 43, 48, 52.
NR Band n78	3300 MHz – 3800 MHz	-43 dBm	1 MHz	This is not applicable to BS operating in Band 22, 42, 43, 48, 52.
NR Band n79	4.4 – 5.0 GHz	-43 dBm	1 MHz	
NR Band n80	1710 – 1785 MHz	-40 dBm	1 MHz	This requirement does not apply to BS operating in band 3
NR Band n81	880 – 915 MHz	-40 dBm	1 MHz	This requirement does not apply to BS operating in band 8
NR Band n82	832 – 862 MHz	-40 dBm	1 MHz	This requirement does not apply to BS operating in band 20.
NR Band n83	703 – 748 MHz	-40 dBm	1 MHz	This requirement does not apply to BS operating in band 28
NR Band n84	1920 – 1980 MHz	-40 dBm	1 MHz	This requirement does not apply to BS operating in band 1
E-UTRA Band 85 or NR band n85	728 - 746 MHz	-43 dBm	1 MHz	This requirement does not apply to BS operating in band 12, 29, 85.
	698 - 716 MHz	-40 dBm	1 MHz	This requirement does not apply to E-UTRA BS operating in Band 85, since it is already covered by the requirement in subclause 6.6.1.2. For E-UTRA BS operating in Band 29, it applies 1 MHz below the Band 29 downlink operating band (Note 7).
NR Band n86	1710 – 1780 MHz	-40 dBm	1 MHz	This requirement does not apply to BS operating in band 66
E-UTRA Band 87	420 - 425 MHz	-43 dBm	1 MHz	This requirement does not apply to BS operating in band 87 or 88.
	410 – 415 MHz	-40 dBm	1 MHz	This requirement does not apply to BS operating in band 87, since it is already covered by the requirement in subclause 6.6.1.2
E-UTRA Band 88	422 - 427 MHz	-43 dBm	1 MHz	This requirement does not apply to BS operating in band 87 or 88.
	412 - 417 MHz	-40 dBm	1 MHz	This requirement does not apply to BS operating in band 88, since it is already covered by the requirement in subclause 6.6.1.2. This requirement does not apply to BS operating in band 87.
NR Band n89	824 - 849 MHz	-40 dBm	1 MHz	This requirement does not apply to BS operating in band 5 or 26, since it is already covered by the requirement in subclause 9.7.6.4.2. For BS operating in Band 27, it applies 3 MHz below the Band 27 downlink operating band.

NR Band n91	1427 - 1432 MHz	-43 dBm	1 MHz	This requirement does not apply to BS operating in Band 50, 51, 75, 76.
	832 – 862 MHz	-40 dBm	1 MHz	This requirement does not apply to BS operating in band 20.
NR Band n92	1432 - 1517 MHz	-43 dBm	1 MHz	This requirement does not apply to BS operating in Band 11, 21, 32, 45, 50, 51, 74, 75, 76.
	832 – 862 MHz	-40 dBm	1 MHz	This requirement does not apply to BS operating in band 20.
NR Band n93	1427 - 1432 MHz	-43 dBm	1 MHz	This requirement does not apply to BS operating in Band 50, 51, 75, 76.
	880 – 915 MHz	-40 dBm	1 MHz	This requirement does not apply to BS operating in band 8
NR Band n94	1432 - 1517 MHz	-43 dBm	1 MHz	This requirement does not apply to BS operating in Band 11, 21, 32, 45, 50, 51, 74, 75, 76.
	880 – 915 MHz	-40 dBm	1 MHz	This requirement does not apply to BS operating in band 8
NR Band n95	2010 - 2025 MHz	-43 dBm	1 MHz	
NR Band n96	5925 - 7125 MHz	-43 dBm	1 MHz	
NR Band n97	2300 – 2400MHz	-43 dBm	1 MHz	
NR Band n98	1880 – 1920MHz	-43 dBm	1 MHz	
NR Band n99	1626.5 – 1660.5 MHz	-40 dBm	1 MHz	This requirement does not apply to BS operating in band 24, since it is already covered by the requirement in subclause 9.7.6.4.2.
NR Band n102	5925 - 6425 MHz	-43 dBm	1 MHz	
E-UTRA Band 103	757 – 758 MHz	-43 dBm	1 MHz	
	787 – 788 MHz	-40 dBm	1 MHz	
NR Band n104	6425 – 7125 MHz	-43 dBm	1 MHz	

NOTE 1: As defined in the scope for spurious emissions in this subclause, except for the cases where the noted requirements apply to a BS operating in Band 25, Band 27, Band 28 or Band 29, the co-existence requirements in table 9.7.6.2.3.2-1 do not apply for the  $\Delta f_{\text{OBUE}}$  frequency range immediately outside the *downlink operating band* (see subclause 9.7.1). Emission limits for this excluded frequency range may be covered by local or regional requirements.

NOTE 2: Table 9.7.6.2.3.2-1 assumes that two operating bands, where the frequency ranges in subclause 9.7.1 would be overlapping, are not deployed in the same geographical area. For such a case of operation with overlapping frequency arrangements in the same geographical area, special co-existence requirements may apply that are not covered by the 3GPP specifications.

NOTE 3: For the protection of DCS1800, UTRA Band III or E-UTRA Band 3 in China, the frequency ranges of the downlink and uplink protection requirements are 1805 – 1850 MHz and 1710 – 1755 MHz respectively.

NOTE 4: TDD base stations deployed in the same geographical area, that are synchronized and use the same or adjacent operating bands can transmit without additional co-existence requirements. For unsynchronized base stations (except in Band 46, or in Band 49), special co-existence requirements may apply that are not covered by the 3GPP specifications.

NOTE 6: For Band 28 BS, specific solutions may be required to fulfil the spurious emissions limits for BS for co-existence with Band 27 UL operating band.

NOTE 7: For Band 29 BS, specific solutions may be required to fulfil the spurious emissions limits for BS for co-existence with UTRA Band XII or E-UTRA Band 12 UL operating band, E-UTRA Band 17 UL operating band or E-UTRA Band 85 UL operating band.

The following requirement may be applied for the protection of PHS. This requirement is also applicable at specified frequencies falling between  $\Delta f_{\text{OBUE}}$  below the lowest BS transmitter frequency of the *downlink operating band* and  $\Delta f_{\text{OBUE}}$  above the highest BS transmitter frequency of the *downlink operating band*.

The TRP of any spurious emission shall not exceed:

**Table 9.7.6.4.3.2-2: AAS BS OTA Spurious emissions limits for BS for co-existence with PHS**

Frequency range	Maximum Level	Measurement Bandwidth	Notes
1884.5 - 1915.7 MHz	-32 dBm	300 kHz	Applicable for co-existence with PHS system operating in 1884.5-1915.7MHz
NOTE: The requirement is not applicable in China.			

The following requirement shall be applied to AAS BS operating in Bands 13 and 14 to ensure that appropriate interference protection is provided to 700 MHz public safety operations. This requirement is also applicable at the frequency range from  $\Delta f_{\text{OBUE}}$  below the lowest frequency of the BS *downlink operating band* up to  $\Delta f_{\text{OBUE}}$  above the highest frequency of the BS *downlink operating band*.

The TRP of any spurious emission shall not exceed:

**Table 9.7.6.4.3.2-3: AAS BS OTA Spurious emissions limits for protection of 700 MHz public safety operations**

Operating Band	Frequency range	Maximum Level	Measurement Bandwidth	Notes
13	763 - 775 MHz	-37 dBm	6.25 kHz	
13	793 - 805 MHz	-37 dBm	6.25 kHz	
14	769 - 775 MHz	-37 dBm	6.25 kHz	
14	799 - 805 MHz	-37 dBm	6.25 kHz	

The following requirement shall be applied to AAS BS operating in Band 26 to ensure that appropriate interference protection is provided to 800 MHz public safety operations. This requirement is also applicable at the frequency range from  $\Delta f_{\text{OBUE}}$  below the lowest frequency of the BS *downlink operating band* up to  $\Delta f_{\text{OBUE}}$  above the highest frequency of the BS *downlink operating band*.

The TRP of any spurious emission shall not exceed:

**Table 9.7.6.4.3.2-4: AAS BS OTA Spurious emissions limits for protection of 800 MHz public safety operations**

Operating Band	Frequency range	Maximum Level	Measurement Bandwidth	Notes
26	851 - 859 MHz	-4 dBm	100 kHz	Applicable for offsets > 37.5kHz from the channel edge

**Table 9.7.6.4.3.2-5: Void**

The following requirement may apply to AAS BS operating in Band 30 in certain regions. This requirement is also applicable at the frequency range from  $\Delta f_{\text{OBUE}}$  below the lowest frequency of the BS *downlink operating band* up to  $\Delta f_{\text{OBUE}}$  above the highest frequency of the BS *downlink operating band*.

The TRP of any spurious emission shall not exceed:

**Table 9.7.6.4.3.2-6: Additional AAS BS OTA Spurious emissions limits for Band 30**

Frequency range	Maximum Level	Measurement Bandwidth	Notes
2200MHz – 2345MHz	-36 dBm	1 MHz	
2362.5MHz – 2365MHz	-16 dBm	1 MHz	
2365MHz – 2367.5MHz	-31 dBm	1 MHz	
2367.5MHz – 2370MHz	-33 dBm	1 MHz	
2370MHz – 2395MHz	-36 dBm	1 MHz	

The following requirement may apply to AAS BS operating in Band 48 in certain regions. The TRP of any spurious emission shall not exceed:

**Table 9.7.6.4.3.2-7: Additional AAS BS OTA Spurious emissions limits for Band 48**

Frequency range	Maximum Level	Measurement Bandwidth	Notes
3530MHz – 3720MHz	-16 dBm	1 MHz	Applicable 10MHz from the assigned channel edge
3100MHz – 3530MHz 3720MHz – 4200MHz	-31 dBm	1 MHz	

In addition to the requirements in subclauses 9.7.6.2.1, 9.7.6.2.2 and above in the present subclause, the AAS BS may have to comply with the applicable emission limits established by FCC Title 47 [15], when deployed in regions where those limits are applied, and under the conditions declared by the manufacturer.

**Table 9.7.6.4.3.2-8: Void**

The following requirement shall be applied to AAS BS operating in Bands 13 and 14 to ensure that appropriate interference protection is provided to 700 MHz public safety operations. This requirement is also applicable at the frequency range from  $\Delta f_{\text{OBUE}}$  below the lowest frequency of the BS *downlink operating band* up to  $\Delta f_{\text{OBUE}}$  above the highest frequency of the BS *downlink operating band*.

The TRP of any spurious emission shall not exceed:

**Table 9.7.6.4.3.2-9: AAS BS OTA Spurious emissions limits for protection of 700 MHz public safety operations**

Operating Band	Frequency range	Maximum Level	Measurement Bandwidth	Notes
13	763 - 775 MHz	-37 dBm	6.25 kHz	
13	793 - 805 MHz	-37 dBm	6.25 kHz	
14	769 - 775 MHz	-37 dBm	6.25 kHz	
14	799 - 805 MHz	-37 dBm	6.25 kHz	

The following requirement shall be applied to AAS BS operating in Band 26 to ensure that appropriate interference protection is provided to 800 MHz public safety operations. This requirement is also applicable at the frequency range from  $\Delta f_{\text{OBUE}}$  below the lowest frequency of the BS *downlink operating band* up to  $\Delta f_{\text{OBUE}}$  above the highest frequency of the BS *downlink operating band*.

The TRP of any spurious emission shall not exceed:

**Table 9.7.6.4.3.2-10: AAS BS OTA Spurious emissions limits for protection of 800 MHz public safety operations**

Operating Band	Frequency range	Maximum Level	Measurement Bandwidth	Notes
26	851 - 859 MHz	-13 dBm	100 kHz	Applicable for offsets > 37.5kHz from the channel edge

#### 9.7.6.4.4 Co-location with other base stations

##### 9.7.6.4.4.1 General

These requirements may be applied for the protection of other BS receivers when GSM900, DCS1800, PCS1900, GSM850, CDMA850, UTRA FDD, UTRA TDD E-UTRA BS and/or NR BS are co-located with a BS.

The requirements assume with base stations of the same class.

NOTE: For co-location with UTRA, the requirements are based on co-location with UTRA FDD or TDD base stations.

The requirement is a co-location requirement. The power levels are specified at the *co-location reference antenna* output.

##### 9.7.6.4.4.2 Minimum Requirement

The power sum of any spurious emission is specified over all supported polarizations of the *co-location reference antenna* and shall not exceed the limits of table 9.7.6.4.4.2-1 for a AAS BS where requirements for co-location with a BS type listed in the first column apply, depending on the declared Base Station class. For a *multi-band RIB*, the exclusions and conditions in the notes column of table 9.7.6.4.4.2-1 apply for each supported operating band.

**Table 9.7.6.4.4.2-1: AAS BS OTA Spurious emissions limits for AAS BS co-located with another BS**

Type of co-located BS	Frequency range for co-location requirement	Maximum Level (WA-BS)	Maximum Level (MR-BS)	Maximum Level (LA-BS)	Measurement Band width	Notes
GSM900	876-915 MHz	-119 dBm	-112 dBm	-109 dBm	100 kHz	
DCS1800	1710 - 1785 MHz	-119 dBm	-112 dBm	-109 dBm	100 kHz	
PCS1900	1850 - 1910 MHz	-119 dBm	-112 dBm	-109 dBm	100 kHz	
GSM850 or CDMA850	824 - 849 MHz	-119 dBm	-112 dBm	-109 dBm	100 kHz	
UTRA FDD Band I or E-UTRA Band 1 or NR band n1	1920 - 1980 MHz	-117 dBm	-112 dBm	-109 dBm	100 kHz	
UTRA FDD Band II or E-UTRA Band 2 or NR band n2	1850 - 1910 MHz	-117 dBm	-112 dBm	-109 dBm	100 kHz	
UTRA FDD Band III or E-UTRA Band 3 or NR band n3	1710 - 1785 MHz	-117 dBm	-112 dBm	-109 dBm	100 kHz	
UTRA FDD Band IV or E-UTRA Band 4	1710 - 1755 MHz	-117 dBm	-112 dBm	-109 dBm	100 kHz	
UTRA FDD Band V or E-UTRA Band 5 or NR band n5	824 - 849 MHz	-117 dBm	-112 dBm	-109 dBm	100 kHz	
UTRA FDD Band VI, XIX or E-UTRA Band 6, 19	830 - 845 MHz	-117 dBm	-112 dBm	-109 dBm	100 kHz	
UTRA FDD Band VII or E-UTRA Band 7 or NR band n7	2500 - 2570 MHz	-117 dBm	-112 dBm	-109 dBm	100 kHz	
UTRA FDD Band VIII or E-UTRA Band 8 or NR band n8	880 - 915 MHz	-117 dBm	-112 dBm	-109 dBm	100 kHz	
UTRA FDD Band IX or E-UTRA Band 9	1749.9 - 1784.9 MHz	-117 dBm	-112 dBm	-109 dBm	100 kHz	
UTRA FDD Band X or E-UTRA Band 10	1710 - 1770 MHz	-117 dBm	-112 dBm	-109 dBm	100 kHz	
UTRA FDD Band XI or E-UTRA Band 11	1427.9 - 1447.9 MHz	-117 dBm	-112 dBm	-109 dBm	100 kHz	This is not applicable to E-UTRA BS operating in Band 50 or 75

Type of co-located BS	Frequency range for co-location requirement	Maximum Level (WA-BS)	Maximum Level (MR-BS)	Maximum Level (LA-BS)	Measurement Band width	Notes
GSM900	876-915 MHz	-119 dBm	-112 dBm	-109 dBm	100 kHz	
UTRA FDD Band XII or E-UTRA Band 12 or NR band n12	699 - 716 MHz	-117 dBm	-112 dBm	-109 dBm	100 kHz	
UTRA FDD Band XIII or E-UTRA Band 13 or NR band n13	777 - 787 MHz	-117 dBm	-112 dBm	-109 dBm	100 kHz	
UTRA FDD Band XIV or E-UTRA Band 14 or NR band n14	788 - 798 MHz	-117 dBm	-112 dBm	-109 dBm	100 kHz	
E-UTRA Band 17	704 - 716 MHz	-117 dBm	-112 dBm	-109 dBm	100 kHz	
E-UTRA Band 18 or NR Band n18	815 - 830 MHz	-117 dBm	-112 dBm	-109 dBm	100 kHz	
UTRA FDD Band XX or E-UTRA Band 20 or NR band n20	832 - 862 MHz	-117 dBm	-112 dBm	-109 dBm	100 kHz	
UTRA FDD Band XXI or E-UTRA Band 21	1447.9 – 1462.9 MHz	-117 dBm	-112 dBm	-109 dBm	100 kHz	This is not applicable to E-UTRA BS operating in Band 32, 50 or 75
UTRA FDD Band XXII or E-UTRA Band 22	3410 – 3490 MHz	-117 dBm	-112 dBm	-109 dBm	100 kHz	This is not applicable to BS operating in Band 42
E-UTRA Band 24 or NR band n24	1626.5 – 1660.5 MHz	-117 dBm	-112 dBm	-109 dBm	100 kHz	
UTRA FDD Band XXV or E-UTRA Band 25 or NR band n25	1850 - 1915 MHz	-117 dBm	-112 dBm	-109 dBm	100 kHz	
UTRA FDD Band XXVI or E-UTRA Band 26 or NR band n26	814 - 849 MHz	-117 dBm	-112 dBm	-109 dBm	100 kHz	
E-UTRA Band 27	807 - 824 MHz	-117 dBm	-112 dBm	-109 dBm	100 kHz	
E-UTRA Band 28 or NR band n28	703 – 748 MHz	-117 dBm	-112 dBm	-109 dBm	100 kHz	This is not applicable to BS operating in Band 44

Type of co-located BS	Frequency range for co-location requirement	Maximum Level (WA-BS)	Maximum Level (MR-BS)	Maximum Level (LA-BS)	Measurement Band width	Notes
GSM900	876-915 MHz	-119 dBm	-112 dBm	-109 dBm	100 kHz	
E-UTRA Band 30 or NR band n30	2305 - 2315 MHz	-117 dBm	-112 dBm	-109 dBm	100 kHz	This is not applicable to BS operating in Band 40
E-UTRA Band 31	452.5 – 457.5 MHz	-117 dBm	-112 dBm	-109 dBm	100 kHz	
UTRA TDD Band a) or E-UTRA Band 33	1900 - 1920 MHz	-117 dBm	-112 dBm	-109 dBm	100 kHz	This is not applicable to BS operating in Band 33
UTRA TDD Band a) or E-UTRA Band 34 or NR band n34	2010 - 2025 MHz	-117 dBm	-112 dBm	-109 dBm	100 kHz	This is not applicable to BS operating in Band 34
UTRA TDD Band b) or E-UTRA Band 35	1850 – 1910 MHz	-117 dBm	-112 dBm	-109 dBm	100 kHz	This is not applicable to BS operating in Band 35
UTRA TDD Band b) or E-UTRA Band 36	1930 - 1990 MHz	-117 dBm	-112 dBm	-109 dBm	100 kHz	This is not applicable to BS operating in Band 2 and 36
UTRA TDD Band c) or E-UTRA Band 37	1910 - 1930 MHz	-117 dBm	-112 dBm	-109 dBm	100 kHz	This is not applicable to BS operating in Band 37. This unpaired band is defined in ITU-R M.1036, but is pending any future deployment.
UTRA TDD Band d) or E-UTRA Band 38 or NR band n38	2570 – 2620 MHz	-117 dBm	-112 dBm	-109 dBm	100 kHz	This is not applicable to BS operating in Band 38.
UTRA TDD Band f) or E-UTRA Band 39 or NR band n39	1880 – 1920MHz	-117 dBm	-112 dBm	-109 dBm	100 kHz	This is not applicable to BS operating in Band 33 and 39
UTRA TDD Band e) or E-UTRA Band 40 or NR band n40	2300 – 2400MHz	-117 dBm	-112 dBm	-109 dBm	100 kHz	This is not applicable to BS operating in Band 30 or 40
E-UTRA Band 41 or NR band n41	2496 – 2690MHz	-117 dBm	-112 dBm	-109 dBm	100 kHz	This is not applicable to BS operating in Band 41 or 53
E-UTRA Band 42	3400 – 3600 MHz	-117 dBm	-112 dBm	-109 dBm	100 kHz	This is not applicable to BS operating in Band 22, 42, 43, 48, 52
E-UTRA Band 43	3600 – 3800 MHz	-117 dBm	-112 dBm	-109 dBm	100 kHz	This is not applicable to BS operating in Band 42, 43, 48
E-UTRA Band 44	703 – 803 MHz	-117 dBm	-112 dBm	-109 dBm	100 kHz	This is not applicable to BS operating in Band 28 or 44

Type of co-located BS	Frequency range for co-location requirement	Maximum Level (WA-BS)	Maximum Level (MR-BS)	Maximum Level (LA-BS)	Measurement Band width	Notes
GSM900	876-915 MHz	-119 dBm	-112 dBm	-109 dBm	100 kHz	
E-UTRA Band 45	1447 – 1467 MHz	-117 dBm	-112 dBm	-109 dBm	100 kHz	This is not applicable to BS operating in Band 45
E-UTRA Band 46 or NR Band n46	5150 – 5925 MHz	N/A	-112 dBm	-109 dBm	100 kHz	
E-UTRA Band 48 or NR Band n48	3550 – 3700 MHz	-117 dBm	-112 dBm	-109 dBm	100 kHz	This is not applicable to BS operating in Band 42, 43, 48.
E-UTRA Band 49	3550 – 3700 MHz	N/A	N/A	-109 dBm	100 kHz	This is not applicable to BS operating in Band 42, 43, 48.
E-UTRA Band 50 or NR band n50	1432 – 1517 MHz	-117 dBm	-112 dBm	-109 dBm	100 kHz	This is not applicable to BS operating in Band 11, 21, 32, 51, 74, 75, 76.
E-UTRA Band 51 or NR Band n51	1427 – 1432 MHz	N/A	N/A	-109 dBm	100 kHz	This is not applicable to BS operating in Band 50, 75, 76.
E-UTRA Band 52	3300 – 3400 MHz	-117 dBm	-112 dBm	-109 dBm	100 kHz	This is not applicable to BS operating in Band 42 or 52
E-UTRA Band 53 or NR band n53	2483.5 – 2495 MHz	N/A	-112 dBm	-109 dBm	100 kHz	This is not applicable to BS operating in Band 41 or 53
E-UTRA Band 65 or NR band n65	1920 - 2010 MHz	-117 dBm	-112 dBm	-109 dBm	100 kHz	
E-UTRA Band 66 or NR band n66	1710 – 1780 MHz	-117 dBm	-112 dBm	-109 dBm	100 kHz	
E-UTRA Band 68	698 – 728 MHz	-117 dBm	-112 dBm	-109 dBm	100 kHz	
E-UTRA Band 70 or NR band n70	1695 – 1710 MHz	-117 dBm	-112 dBm	-109 dBm	100 kHz	
E-UTRA Band 71 or NR Band n71	663 – 698 MHz	-117 dBm	-112 dBm	-109 dBm	100 kHz	
E-UTRA Band 72	451 – 456 MHz	-117 dBm	-112 dBm	-109 dBm	100 kHz	
E-UTRA Band 73	450 – 455 MHz	-117 dBm	-112 dBm	-109 dBm	100 kHz	
E-UTRA Band 74 or NR band n74	1427 – 1470 MHz	-117 dBm	-112 dBm	-109 dBm	100 kHz	This is not applicable to BS operating in Band 50, 51
NR Band n77	3300 MHz – 4200 MHz	-117 dBm	-112 dBm	-109 dBm	100 kHz	This is not applicable to BS operating in Band 22, 42 43, 48, 52.

Type of co-located BS	Frequency range for co-location requirement	Maximum Level (WA-BS)	Maximum Level (MR-BS)	Maximum Level (LA-BS)	Measurement Band width	Notes
GSM900	876-915 MHz	-119 dBm	-112 dBm	-109 dBm	100 kHz	
NR Band n78	3300 MHz – 3800 MHz	-117 dBm	-112 dBm	-109 dBm	100 kHz	This is not applicable to BS operating in Band 22, 42, 43, 48, 52.
NR Band n79	4.4 – 5.0 GHz	-117 dBm	-112 dBm	-109 dBm	100 kHz	
NR Band n80	1710 – 1785 MHz	-117 dBm	-112 dBm	-109 dBm	100 kHz	
NR Band n81	880 – 915 MHz	-117 dBm	-112 dBm	-109 dBm	100 kHz	
NR Band n82	832 – 862 MHz	-117 dBm	-112 dBm	-109 dBm	100 kHz	
NR Band n83	703 – 748 MHz	-117 dBm	-112 dBm	-109 dBm	100 kHz	
NR Band n84	1920 – 1980 MHz	-117 dBm	-112 dBm	-109 dBm	100 kHz	
E-UTRA Band 85 or NR band n85	698 - 716 MHz	-117 dBm	-112 dBm	-109 dBm	100 kHz	
NR Band n86	1710 – 1780 MHz	-117 dBm	-112 dBm	-109 dBm	100 kHz	
E-UTRA Band 87	410 – 415 MHz	-117 dBm	-112 dBm	-109 dBm	100 kHz	
E-UTRA Band 88	412 – 417 MHz	-117 dBm	-112 dBm	-109 dBm	100 kHz	
NR Band n89	824 - 849 MHz	-117 dBm	-112 dBm	-109 dBm	100 kHz	
NR Band n91	832 – 862 MHz	N/A	N/A	-109 dBm	100 kHz	
NR Band n92	832 – 862 MHz	-117 dBm	-112 dBm	-109 dBm	100 kHz	
NR Band n93	880 – 915 MHz	N/A	N/A	-109 dBm	100 kHz	
NR Band n94	880 – 915 MHz	-117 dBm	-112 dBm	-109 dBm	100 kHz	
NR Band n95	2010 - 2025 MHz	-117 dBm	-112 dBm	-109 dBm	100 kHz	
NR Band n96	5925 - 7125 MHz	N/A	-111 dBm	-108 dBm	100 kHz	
NR Band n97	2300 – 2400MHz	-117 dBm	-112 dBm	-109 dBm	100 kHz	
NR Band n98	1880 – 1920MHz	-117 dBm	-112 dBm	-109 dBm	100 kHz	
NR Band n99	1626.5 – 1660.5 MHz	-117 dBm	-112 dBm	-109 dBm	100 kHz	
NR Band n102	5925 - 6425 MHz	N/A	-111 dBm	-108 dBm	100 kHz	
E-UTRA Band 103	787 – 788 MHz	-117dBm	-112 dBm	-109dBm	100 kHz	
NR Band n104	6425 – 7125 MHz	-116 dBm	-111 dBm	-108 dBm	100 kHz	

NOTE 1: As defined in the scope for spurious emissions in this subclause, the co-location requirements in table 9.7.6.4.4.2-1 do not apply for the  $\Delta f_{\text{OBUE}}$  frequency range immediately outside the BS transmit frequency range of a *downlink operating band* (see subclause 9.7.1). The current state-of-the-art technology does not allow a single generic solution for co-location with other system on adjacent frequencies for 30 dB BS-BS minimum coupling loss. However, there are certain site-engineering solutions that can be used. These techniques are addressed in TR 25.942 [12].

NOTE 2: Table 9.7.6.4.4.2-1 assumes that two operating bands, where the corresponding BS transmit and receive frequency ranges in subclause 9.7.1 would be overlapping, are not deployed in the same geographical area. For such a case of operation with overlapping frequency arrangements in the same geographical area, special co-location requirements may apply that are not covered by the 3GPP specifications.

NOTE 3: Co-located TDD base stations that are synchronized and using the same or adjacent operating band can transmit without special co-locations requirements. For unsynchronized base stations, special co-location requirements may apply that are not covered by the 3GPP specifications.

## 9.8 OTA Transmitter intermodulation

### 9.8.1 General

The OTA transmitter intermodulation requirement is a measure of the capability of the transmitter unit to inhibit the generation of signals in its non-linear elements caused by presence of the wanted signal and an interfering signal reaching the transmitter unit via the RDN and antenna array from a co-located base station. The requirement applies during the *transmitter ON period* and the *transmitter transient period*.

The requirement applies at each RIB supporting transmission in the operating band.

The transmitter intermodulation level is the *total radiated power* of the intermodulation products when an interfering signal is injected into the *co-location reference antenna*.

### 9.8.2 Minimum requirement for MSR operation

#### 9.8.2.1 General minimum requirement

The transmitter intermodulation level shall not exceed the unwanted emission limits specified for OTA transmitter spurious emission in subclause 9.7.6.1, 9.7.6.2.1 and 9.7.6.2.3, OTA operating band unwanted emission in subclause 9.7.5 and OTA ACLR in subclause 9.7.3 in the presence of a wanted signal and an interfering signal according to table 9.8.2.1-1 for *OTA AAS BS* operation in BC1, BC2 and BC3.

The requirement is applicable outside the *Base Station RF Bandwidth edges*. The interfering signal offset is defined relative to the *Base Station RF Bandwidth edges* or *Radio Bandwidth edges*.

For RIBs supporting operation in *non-contiguous spectrum*, the requirement is also applicable inside a *sub-block gap* for interfering signal offsets where the interfering signal falls completely within the *sub-block gap*. The interfering signal offset is defined relative to the *sub-block edges*.

For *multi-band RIBs*, the requirement applies relative to the *Base Station RF Bandwidth edges* of each operating band. In case the inter *Base Station RF Bandwidth gap* is less than 15 MHz, the requirement in the gap applies only for interfering signal offsets where the interfering signal falls completely within the inter *Base Station RF Bandwidth gap*.

**Table 9.8.2.1-1: Interfering signal for the OTA transmitter intermodulation requirement**

Parameter	Value
Wanted signal type	E-UTRA or NR signal
Interfering signal type	E-UTRA signal of <i>channel bandwidth</i> 5 MHz
Interfering signal power level applied to the <i>co-location reference antenna</i>	min(46 dBm, $P_{\text{rated,t,TRP}}$ )
Interfering signal centre frequency offset from <i>Base Station RF Bandwidth</i> edge or edge of <i>sub-block</i> inside a gap	±2.5 MHz ±7.5 MHz ±12.5 MHz
NOTE 1: Interfering signal positions that are partially or completely outside of any <i>downlink operating band</i> of the RIB is excluded from the requirement, unless the interfering signal positions fall within the frequency range of adjacent <i>downlink operating bands</i> in the same geographical area. In case that none of the interfering signal positions fall completely within the frequency range of the <i>downlink operating band</i> , 3GPP TS 37.141 [19] provides further guidance regarding appropriate test requirements.	
NOTE 2: In certain regions, NOTE 1 is not applied in Band 1, 3, 8, 9, 11, 18, 19, 21, 28, 32 operating within 1 475.9 MHz to 1 495.9 MHz, 34.	
NOTE 3: For OTA AAS BS with dual polarization, the interfering signal power shall be equally divided between the supported polarizations at the <i>co-location reference antenna</i> .	

### 9.8.2.2 Additional minimum requirement (BC1 and BC2)

The transmitter intermodulation level shall not exceed the unwanted emission limits specified for transmitter spurious emission in subclause 9.7.6.1, 9.7.6.2.1 and 9.7.6.2.3 operating band unwanted emission in subclause 9.7.5 and ACLR in subclause 9.7.3 in the presence of a wanted signal and an interfering signal according to table 9.8.2.2-1 for BS operation in BC2.

The requirement is applicable outside the *Base Station RF Bandwidth* edges for BC2. The interfering signal offset is defined relative to the *Base Station RF Bandwidth* edges.

For RIBs supporting operation in *non-contiguous spectrum* in BC1 or BC2, the requirement is also applicable inside a *sub-block gap* with a gap size larger than or equal to two times the interfering signal centre frequency offset. For RIBs supporting operation in *non-contiguous spectrum* in BC1, the requirement is not applicable inside a *sub-block gap* with a gap size equal to or larger than 5 MHz. The interfering signal offset is defined relative to the *sub-block* edges.

For *multi-band RIBs*, the requirement applies relative to the *Base Station RF Bandwidth* edges of a BC2 operating band. The requirement is also applicable for BC1 and BC2 inside an inter *Base Station RF Bandwidth* gap equal to or larger than two times the interfering signal centre frequency offset. For RIBs supporting operation in multiple operating bands, the requirement is not applicable for BC1 band inside an inter *Base Station RF Bandwidth* gap with a gap size equal to or larger than 5 MHz.

**Table 9.8.2.2-1: Interfering and wanted signals for the OTA transmitter intermodulation requirement**

Parameter	Value
Wanted signal type	E-UTRA or NR or UTRA signal
Interfering signal type	CW
Interfering signal power level applied to the <i>co-location reference antenna</i>	min(46 dBm, $P_{\text{rated,t,TRP}}$ )
Interfering signal centre frequency offset from <i>Base Station RF Bandwidth</i> edge or edge of <i>sub-block</i> inside a gap	> abs(800) kHz for CW interfering signal
NOTE 1: Interfering signal positions that are partially or completely outside of any <i>downlink operating band</i> of the RIB are excluded from the requirement.	
NOTE 2: For OTA AAS BS with dual polarization, the interfering signal power shall be equally divided between the supported polarizations at the <i>co-location reference antenna</i> .	

### 9.8.2.3 Additional minimum requirement (BC3)

This additional requirement shall only apply for BS co-located with an UTRA TDD BS.

The transmitter intermodulation level shall not exceed the unwanted emission limits specified for OTA transmitter spurious emission in subclause 9.7.6.1, 9.7.6.2.1 and 9.7.6.2.3 OTA operating band unwanted emission in subclause 9.7.5 and OTA ACLR in subclause 9.7.3 in the presence of a wanted signal and an interfering signal according to table 9.8.2.3-1 for AAS BS operation in BC3.

For *multi-band RIBs*, the requirement applies relative to *the Base Station RF Bandwidth edges* of each operating band. In case the *Inter RF Bandwidth gap* is less than 3.2 MHz, the requirement in the gap applies only for interfering signal offsets where the interfering signal falls completely within the inter *Base Station RF Bandwidth gap*.

**Table 9.8.2.3-1: Interfering and wanted signals for the OTA transmitter intermodulation requirement (BC3)**

Parameter	Value
Wanted signal type	E-UTRA or NR or UTRA signal
Interfering signal type	1,28 Mcps UTRA TDD signal of <i>channel bandwidth 1,6 MHz</i>
Interfering signal power level applied to the <i>co-location reference antenna</i>	min(46 dBm, $P_{\text{rated,t,TRP}}$ )
Interfering signal centre frequency offset from <i>Base Station RF Bandwidth edge</i> or <i>edge of sub-block</i> inside a gap	±0,8 MHz ±1,6 MHz ±2,4 MHz
NOTE 1: Interfering signal positions that are partially or completely outside of any <i>downlink operating band</i> of the base station are excluded from the requirement.	
NOTE 2: For <i>OTA AAS BS</i> with dual polarization, the interfering signal power shall be equally divided between the supported polarizations at the <i>co-location reference antenna</i> .	

### 9.8.2.4 Additional minimum requirements

## 9.8.3 Minimum requirement for single RAT UTRA operation

### 9.8.3.1 General minimum requirement for FDD UTRA

The transmitter intermodulation level shall not exceed the OTA out of band emission or the OTA spurious emission requirements of subclause 9.7.5 and subclause 9.7.6.1, 9.7.6.3.1 and 9.7.6.3.3, in the presence of interfering signal according to table 9.8.3.1-1.

**Table 9.8.3.1-1: Interfering and wanted signal frequency offset for OTA transmitter intermodulation requirement**

Parameter	Value
Wanted signal type	UTRA
Interfering signal type	UTRA
Interfering signal power level applied to the <i>co-location reference antenna</i>	min(46 dBm, $P_{\text{rated,t,TRP}}$ )
Interfering signal centre frequency offset from the lower (upper) edge of the wanted signal or edge of <i>sub-block</i> inside a gap	-2,5 MHz -7,5 MHz -12,5 MHz +2,5 MHz +7,5 MHz +12,5 MHz
NOTE 1: Interference frequencies that are outside of any allocated frequency band for UTRA-FDD downlink specified in subclause 4.6 are excluded from the requirement, unless the interfering signal positions fall within the frequency range of adjacent <i>downlink operating bands</i> in the same geographical area.	
NOTE 2: NOTE 1 is not applied in Band I, III, VI, VIII, IX, XI, XIX, XXI, and XXXII operating within 1 475.9 MHz to 1 495.9MHz, in certain regions.	
NOTE 3: For OTA AAS BS with dual polarization, the interfering signal power shall be equally divided between the supported polarizations at the <i>co-location reference antenna</i> .	

For RIBs supporting operation in *non-contiguous spectrum*, the requirement is also applicable inside a *sub-block gap* for interfering signal offsets where the interfering signal falls completely within the *sub-block gap*. The interfering signal offset is defined relative to the *sub-block* edges.

For *multi-band RIBs*, the requirement is also applicable inside an inter *Base Station RF Bandwidth* gap for interfering signal offsets where the interfering signal falls completely within the inter *Base Station RF Bandwidth* gap.

## 9.8.4 Minimum requirement for single RAT E-UTRA operation

### 9.8.4.1 General minimum requirement

The transmitter intermodulation level shall not exceed the unwanted emission limits in subclauses 9.7.6.1, 9.7.6.4.1, 9.7.6.4.3, 9.7.5 and 9.7.3 in the presence of an E-UTRA interfering signal according to table 9.8.4.1-1.

The requirement is applicable outside the *Base Station RF Bandwidth* or *Radio Bandwidth*. The interfering signal offset is defined relative to the *Base Station RF Bandwidth edges* or *Radio Bandwidth edges*.

For RIBs supporting operation in *non-contiguous spectrum*, the requirement is also applicable inside a *sub-block gap* for interfering signal offsets where the interfering signal falls completely within the *sub-block gap*. The interfering signal offset is defined relative to the *sub-block* edges.

For *multi-band RIBs*, the requirement applies relative to the *Base Station RF Bandwidth edges* of each supported operating band. In case the inter *Base Station RF Bandwidth* gap is less than 15 MHz, the requirement in the gap applies only for interfering signal offsets where the interfering signal falls completely within the inter *Base Station RF Bandwidth* gap.

The wanted signal and interfering signal centre frequency is specified in table 9.8.4.1-1.

**Table 9.8.4.1-1: Interfering and wanted signals for the OTA transmitter intermodulation requirement**

Parameter	Value
Wanted signal	E-UTRA single carrier, or multi-carrier, or multiple intra-band contiguously or non-contiguously aggregated carriers
Interfering signal type	E-UTRA signal of <i>channel bandwidth</i> 5 MHz
Interfering signal power level applied to the <i>co-location reference antenna</i>	min(46 dBm, P <sub>rated,t,TRP</sub> )
Interfering signal centre frequency offset from the lower (upper) edge of the wanted signal or edge of <i>sub-block</i> inside a <i>sub-block gap</i>	±2,5 MHz ±7,5 MHz ±12,5 MHz
NOTE 1: Interfering signal positions that are partially or completely outside of any <i>downlink operating band</i> of the base station are excluded from the requirement, unless the interfering signal positions fall within the frequency range of adjacent <i>downlink operating bands</i> in the same geographical area. In case that none of the interfering signal positions fall completely within the frequency range of the <i>downlink operating band</i> , 3GPP TS 36.141 [20] provides further guidance regarding appropriate test requirements.	
NOTE 2: In certain regions, NOTE 1 is not applied in Band 1, 3, 8, 9, 11, 18, 19, 21, 28, 32 operating within 1 475.9 MHz to 1 495.9 MHz, 34, 74.	
NOTE 3: For <i>OTA AAS BS</i> with dual polarization, the interfering signal power shall be equally divided between the supported polarizations at the <i>co-location reference antenna</i> .	

## 9.8.4.2 Void

**Table 9.8.4.2-1: Void**

# 10 Radiated receiver characteristics

## 10.1 General

OTA receiver characteristics requirements apply to the *AAS BS* including all its functional components active unless otherwise stated in each requirement.

Unless otherwise stated the requirements in clause 10 apply during the *AAS BS receive period*.

The requirements in clause 10 shall be met for any transmitter setting.

The (E-UTRA) and NR throughput requirements defined for the receiver characteristics in this clause do not assume HARQ retransmissions.

When the *AAS BS* is configured to receive multiple carriers, all the throughput requirements are applicable for each received carrier.

Each requirement shall be met over the *RoAoA* specified.

For requirements which are to be met over the *OTA REFSENS RoAoA* absolute requirement values are offset by the following term:

$$\Delta_{\text{OTAREFSENS}} = 44.1 - 10 \cdot \log_{10}(\text{Be}W_{\theta, \text{REFSENS}} \cdot \text{Be}W_{\phi, \text{REFSENS}}) \text{ (dB) for the reference direction.}$$

And

$$\Delta_{\text{OTAREFSENS}} = 41.1 - 10 \cdot \log_{10}(\text{Be}W_{\theta, \text{REFSENS}} \cdot \text{Be}W_{\phi, \text{REFSENS}}) \text{ (dB) for all other directions.}$$

For requirements which are to be met over the *minSENS RoAoA* absolute requirement values are offset by the following term:

$$\Delta_{\min\text{SENS}} = P_{\text{REFSENS}} - \text{EIS}_{\min\text{SENS}} \text{ (dB)}$$

## 10.2 OTA sensitivity

### 10.2.1 General

The OTA sensitivity requirement is based upon the declaration of one or more *OTA sensitivity direction declarations* (OSDD), related to an *AAS BS receiver*.

The *AAS BS receiver* may optionally be capable of redirecting/changing the *receiver target* by means of adjusting BS settings resulting in multiple *sensitivity RoAoA*. The *sensitivity RoAoA* resulting from the current AAS BS settings is the active *sensitivity RoAoA*.

If the AAS BS is capable of redirecting the *receiver target* related to the OSDD then the OSDD shall include:

- The set(s) of RAT, *Channel bandwidth* and declared minimum EIS level applicable to any active *sensitivity RoAoA* inside the *receiver target redirection range* in the OSDD.
- A declared *receiver target redirection range*, describing all the angles of arrival that can be addressed for the OSDD through alternative settings in the AAS BS.
- Five declared *sensitivity RoAoA* comprising the conformance testing directions as detailed in TS 37.145-2 [30].
- The *receiver target reference direction*.

NOTE 1: Some of the declared *sensitivity RoAoA* may coincide depending on the redirection capability.

NOTE 2: In addition to the declared *sensitivity RoAoA*, several *sensitivity RoAoA* may be implicitly defined by the *receiver target redirection range* without being explicitly declared in the OSDD.

NOTE 3: (Void)

If the AAS BS is not capable of redirecting the *receiver target* related to the OSDD, then the OSDD includes only:

- The set(s) of RAT, *Channel bandwidth* and declared minimum EIS level applicable to the *sensitivity RoAoA* in the OSDD.
- One declared active *sensitivity RoAoA*.
- The *receiver target reference direction*.

NOTE 4: For AAS BS without target redirection capability, the declared (fixed) *sensitivity RoAoA* is always the active *sensitivity RoAoA*.

The OTA sensitivity EIS level declaration shall apply to each supported polarization, under the assumption of *polarization match*.

### 10.2.2 Minimum requirement for MSR operation

The minimum requirements for a UTRA FDD and for UTRA TDD 1,28 Mcps option carrier OTA sensitivity are defined in subclause 10.2.3.

The minimum requirement for an E-UTRA carrier OTA sensitivity is defined in subclause 10.2.4.

The minimum requirement for an NR carrier OTA sensitivity is the same as that defined for *BS type 1-O* in 3GPP TS 38.104 [28] in subclause 10.2.1.2

### 10.2.3 Minimum requirement for single RAT UTRA operation

For a received signal whose AoA of the incident wave is within the active *sensitivity RoAoA* of an OSDD, the error rate criterion as described below shall be met when the level of the arriving signal is equal to the minimum EIS level in the respective declared set of EIS level, RAT and *channel bandwidth*.

For UTRA FDD, the BER shall not exceed 0,001, using the 12,2 kbps data rate reference measurement channel specified in 3GPP TS 25.104 [2].

For UTRA TDD 1,28 Mcps option, the BER shall not exceed 0,001, using the 12,2 kbps data rate reference measurement channel specified in 3GPP TS 25.105 [3].

NOTE: The requirement applies for all declared sets of EIS, RAT and *channel bandwidth*, within the OSDD comprising UTRA, and for all related active *sensitivity RoAoA* settings within the AAS BS capability.

## 10.2.4 Minimum requirement for single RAT E-UTRA operation

For a received signal whose AoA of the incident wave is within the active *sensitivity RoAoA* of an OSDD the throughput criterion, as described below, shall be met when the level of the arriving signal is equal to the minimum EIS level in the respective declared set of EIS level, RAT and *channel bandwidth*.

The throughput shall be  $\geq 95\%$  of the *maximum throughput* of the reference measurement channel as specified in 3GPP TS 36.104 [4] with parameters specified in table 10.2.4-1.

NOTE 1: The requirement applies for all declared sets of EIS level, RAT and *channel bandwidth*, within the OSDD comprising E-UTRA, and for all related active *sensitivity RoAoA* settings within the AAS BS capability.

**Table 10.2.4-1: E-UTRA AAS BS reference measurement channel**

E-UTRA <i>channel bandwidth</i> [MHz]	Reference measurement channel
1.4	FRC A1-1 in 3GPP TS 36.104 [8], annex A.1
3	FRC A1-2 in 3GPP TS 36.104 [8], annex A.1
5	FRC A1-3 in 3GPP TS 36.104 [8], annex A.1
10	FRC A1-3 in 3GPP TS 36.104 [8], annex A.1 (NOTE)
15	FRC A1-3 in 3GPP TS 36.104 [8], annex A.1 (NOTE)
20	FRC A1-3 in 3GPP TS 36.104 [8], annex A.1 (NOTE)
NOTE:	The declared minimum EIS level is applied to a single instance of the reference measurement channel. This requirement shall be met for each consecutive application of a single instance of FRC A1-3 mapped to disjoint frequency ranges with a width of 25 resource blocks each. This reference measurement channel is not applied for Band 46 nor for Band 49.

NOTE 2: Several OSDD EIS level declarations corresponding to different *channel bandwidths* may be made.

## 10.3 OTA Reference sensitivity level

### 10.3.1 General

The OTA REFSSENS requirement is intended to ensure the OTA reference sensitivity level for a declared *OTA REFSSENS RoAoA*.

The OTA reference sensitivity power level  $EIS_{REFSENS}$  is the mean power received at the RIB at which a reference performance requirement shall be met for a specified reference measurement channel.

The OTA REFSSENS requirement shall apply to each supported polarization, under the assumption of *polarization match*.

### 10.3.2 Minimum requirement for MSR operation

For UTRA, the minimum requirement for reference sensitivity is specified in subclause 10.3.3.

For E-UTRA, the minimum requirement for reference sensitivity is specified in subclause 10.3.4.

For NR, the minimum requirement for reference sensitivity is the same as that specified for *BS type I-O* in 3GPP TS 38.104 [28] in subclause 10.3.2.

### 10.3.3 Minimum requirement for single RAT UTRA operation

If the AoA of the incident wave of a received signal is within the *OTA REFSENS RoAoA*, the error rate criterion as described below shall be met when the level of the arriving signal is equal to  $EIS_{REFSENS}$ .

For UTRA FDD, using the reference measurement channel specified in 3GPP TS 25.104 [2], the OTA reference sensitivity level and performance shall be as specified in table 10.3.3-1.

**Table 10.3.3-1: UTRA FDD OTA reference sensitivity levels**

BS Class	Reference measurement channel data rate	$EIS_{REFSENS}$ [dBm]	BER
Wide Area BS	12.2 kbps	-121 - $\Delta_{OTAREFSNS}$	BER shall not exceed 0.001
Medium Range BS	12.2 kbps	-111 - $\Delta_{OTAREFSNS}$	BER shall not exceed 0.001
Local Area	12.2 kbps	-107 - $\Delta_{OTAREFSNS}$	BER shall not exceed 0.001

### 10.3.4 Minimum requirement for single RAT E-UTRA operation

If the AoA of the incident wave of a received signal is within the *OTA REFSENS RoAoA*, the throughput criterion as described below shall be met when the level of the arriving signal is equal to  $EIS_{REFSENS}$  in the respective declared *channel bandwidth*.

The throughput shall be  $\geq 95\%$  of the *maximum throughput* of the reference measurement channel as specified in 3GPP TS 36.104 [4] with parameters specified in table 10.3.4-1 for Wide Area BS, in table 10.3.4-2 for Local Area BS and in table 10.3.4-3 for Medium Range BS.

**Table 10.3.4-1: E-UTRA Wide area AAS BS OTA reference measurement channel**

E-UTRA channel bandwidth [MHz]	Reference measurement channel	$EIS_{REFSENS}$ [dBm]
1.4	FRC A1-1 in 3GPP TS 36.104 [8], annex A.1	-106.8 - $\Delta_{OTAREFSNS}$
3	FRC A1-2 in 3GPP TS 36.104 [8], annex A.1	-103.0 - $\Delta_{OTAREFSNS}$
5	FRC A1-3 in 3GPP TS 36.104 [8], annex A.1	-101.5 - $\Delta_{OTAREFSNS}$
10	FRC A1-3 in 3GPP TS 36.104 [8], annex A.1 (NOTE)	-101.5 - $\Delta_{OTAREFSNS}$
15	FRC A1-1 in 3GPP TS 36.104 [8], annex A.1 (NOTE)	-101.5 - $\Delta_{OTAREFSNS}$
20	FRC A1-2 in 3GPP TS 36.104 [8], annex A.1 (NOTE)	-101.5 - $\Delta_{OTAREFSNS}$

NOTE:  $EIS_{REFSENS}$  is the power level of a single instance of the reference measurement channel. This requirement shall be met for each consecutive application of a single instance of FRC A1-3 mapped to disjoint frequency ranges with a width of 25 resource blocks each.

**Table 10.3.4-2: E-UTRA Local Area AAS BS OTA reference sensitivity levels**

E-UTRA channel bandwidth [MHz]	Reference measurement channel	$EIS_{REFSENS}$ [dBm]
1.4	FRC A1-1 in Annex A.1	-98.8 - $\Delta_{OTAREFSNS}$
3	FRC A1-2 in Annex A.1	-95.0 - $\Delta_{OTAREFSNS}$
5	FRC A1-3 in Annex A.1	-93.5 - $\Delta_{OTAREFSNS}$
10	FRC A1-3 in Annex A.1 (NOTE 1)	-93.5 - $\Delta_{OTAREFSNS}$
15	FRC A1-3 in Annex A.1 (NOTE 1)	-93.5 - $\Delta_{OTAREFSNS}$
20	FRC A1-3 in Annex A.1 (NOTE 1)	-93.5 - $\Delta_{OTAREFSNS}$

NOTE 1:  $EIS_{REFSENS}$  is the power level of a single instance of the reference measurement channel. This requirement shall be met for each consecutive application of a single instance of FRC A1-3 mapped to disjoint frequency ranges with a width of 25 resource blocks each. This reference measurement channel is not applied for Band 46 nor for Band 49.

NOTE 2: Void

**Table 10.3.4-3: E-UTRA Medium Range BS reference sensitivity levels**

E-UTRA channel bandwidth [MHz]	Reference measurement channel	EIS <sub>REFSENS</sub> [dBm]
1.4	FRC A1-1 in Annex A.1	-101.8 - $\Delta_{OTAREFSENS}$
3	FRC A1-2 in Annex A.1	-98.0 - $\Delta_{OTAREFSENS}$
5	FRC A1-3 in Annex A.1	-96.5 - $\Delta_{OTAREFSENS}$
10	FRC A1-3 in Annex A.1 (NOTE 1) FRC A1-8 in Annex A.1 (NOTE 2)	-96.5 - $\Delta_{OTAREFSENS}$ -99.2 - $\Delta_{OTAREFSENS}$
15	FRC A1-3 in Annex A.1 (NOTE 1)	-96.5 - $\Delta_{OTAREFSENS}$
20	FRC A1-3 in Annex A.1 (NOTE 1) FRC A1-9 in Annex A.1 (NOTE 2)	-96.5 - $\Delta_{OTAREFSENS}$ -99.2 - $\Delta_{OTAREFSENS}$
NOTE 1: EIS <sub>REFSENS</sub> is the power level of a single instance of the reference measurement channel. This requirement shall be met for each consecutive application of a single instance of FRC A1-3 mapped to disjoint frequency ranges with a width of 25 resource blocks each. This reference measurement channel is not applied for Band 46.		
NOTE 2: EIS <sub>REFSENS</sub> is the power level of a single instance of the reference measurement channel. This requirement shall be met for each single interlace of FRC A1-8 and A1-9. This reference measurement channel is only applied for Band 46.		

## 10.4 OTA Dynamic range

### 10.4.1 General

The OTA dynamic range is a measure of the capability of the receiver unit to receive a wanted signal in the presence of an interfering signal inside the received *channel bandwidth* or the capability of receiving high level of wanted signal.

The requirement applies at the RIB when the AoA of the incident wave of a received signal and the interfering signal are from the same direction and are within the OTA REFSENS *RoAoA*.

The wanted and interfering signals apply to each supported polarization, under the assumption of *polarization match*.

### 10.4.2 Minimum requirement for MSR operation

For UTRA, the minimum requirement for dynamic range is specified in subclause 10.4.3.

For E-UTRA, the minimum requirement for dynamic range is specified in subclause 10.4.4.

For NR, the minimum requirement for dynamic range is the same as that specified for BS type 1-O in 3GPP TS 38.104 [28] in subclause 10.4.2

### 10.4.3 Minimum requirement for single RAT UTRA operation

The BER shall not exceed 0.001 for the parameters specified in table 10.4.3-1

**Table 10.4.3-1: Dynamic range**

Parameter	Level Wide Area BS	Level Medium Range BS	Level Local Area BS	Unit
Reference measurement channel data rate	12.2	12.2	12.2	kbps
Wanted signal mean power	-91 - $\Delta_{OTAREFSENS}$	-81 - $\Delta_{OTAREFSENS}$	-77 - $\Delta_{OTAREFSENS}$	dBm
Interfering AWGN signal	-73 - $\Delta_{OTAREFSENS}$	-63 - $\Delta_{OTAREFSENS}$	-59 - $\Delta_{OTAREFSENS}$	dBm/3.84 MHz

#### 10.4.4 Minimum requirement for single RAT E-UTRA operation

For E-UTRA, the throughput shall be  $\geq 95\%$  of the *maximum throughput* of the reference measurement channel as specified in 3GPP TS 36.104 [8], annex A with parameters specified in table 10.4.4-1 for Wide Area BS, in table 10.4.4-2 for Local Area BS and in table 10.4.4-3 for Medium Range BS.

**Table 10.4.4-1: Wide Area BS dynamic range for E-UTRA carrier**

E-UTRA channel bandwidth [MHz]	Reference measurement channel	Wanted signal mean power [dBm]	Interfering signal mean power [dBm] / $BW_{Config}$	Type of interfering signal
1.4	FRC A2-1 in 3GPP TS 36.104 [8], annex A.2	$-76.3 - \Delta_{OTAREFSENS}$	$-88.7 - \Delta_{OTAREFSENS}$	AWGN
3	FRC A2-2 in 3GPP TS 36.104 [8], annex A.2	$-72.4 - \Delta_{OTAREFSENS}$	$-84.7 - \Delta_{OTAREFSENS}$	AWGN
5	FRC A2-3 in 3GPP TS 36.104 [8], annex A.2	$-70.2 - \Delta_{OTAREFSENS}$	$-82.5 - \Delta_{OTAREFSENS}$	AWGN
10	FRC A2-3 in 3GPP TS 36.104 [8], annex A.2 (NOTE)	$-70.2 - \Delta_{OTAREFSENS}$	$-79.5 - \Delta_{OTAREFSENS}$	AWGN
15	FRC A2-3 in 3GPP TS 36.104 [8], annex A.2 (NOTE)	$-70.2 - \Delta_{OTAREFSENS}$	$-77.7 - \Delta_{OTAREFSENS}$	AWGN
20	FRC A2-3 in 3GPP TS 36.104 [8], annex A.2 (NOTE)	$-70.2 - \Delta_{OTAREFSENS}$	$-76.4 - \Delta_{OTAREFSENS}$	AWGN
NOTE: The wanted signal mean power is the power level of a single instance of the reference measurement channel. This requirement shall be met for each consecutive application of a single instance of FRC A2-3 mapped to disjoint frequency ranges with a width of 25 resource blocks each.				

Table 10.4.4-2: Local Area BS dynamic range for E-UTRA carrier

E-UTRA channel bandwidth [MHz]	Reference measurement channel	Wanted signal mean power [dBm]	Interfering signal mean power [dBm] / $BW_{Config}$	Type of interfering signal
1.4	FRC A2-1 in 3GPP TS 36.104 [8], annex A.2	$-68.3 - \Delta_{OTAREFSENS}$	$-80.7 - \Delta_{OTAREFSENS}$	AWGN
3	FRC A2-2 in 3GPP TS 36.104 [8], annex A.2	$-64.4 - \Delta_{OTAREFSENS}$	$-76.7 - \Delta_{OTAREFSENS}$	AWGN
5	FRC A2-3 in 3GPP TS 36.104 [8], annex A.2	$-62.2 - \Delta_{OTAREFSENS}$	$-74.5 - \Delta_{OTAREFSENS}$	AWGN
10	FRC A2-3 in 3GPP TS 36.104 [8], annex A.2 (NOTE 1)	$-62.2 - \Delta_{OTAREFSENS}$	$-71.5 - \Delta_{OTAREFSENS}$	AWGN
15	FRC A2-3 in 3GPP TS 36.104 [8], annex A.2 (NOTE 1)	$-62.2 - \Delta_{OTAREFSENS}$	$-69.7 - \Delta_{OTAREFSENS}$	AWGN
20	FRC A2-3 in 3GPP TS 36.104 [8], annex A.2 (NOTE 1)	$-62.2 - \Delta_{OTAREFSENS}$	$-68.4 - \Delta_{OTAREFSENS}$	AWGN
<p>NOTE 1: The wanted signal mean power is the power level of a single instance of the reference measurement channel. This requirement shall be met for each consecutive application of a single instance of FRC A2-3 mapped to disjoint frequency ranges with a width of 25 resource blocks each. This reference measurement channel is not applied for Band 46 nor for Band 49.</p> <p>NOTE 2: Void</p>				

Table 10.4.4-3: Medium Range BS dynamic range for E-UTRA carrier

E-UTRA channel bandwidth [MHz]	Reference measurement channel	Wanted signal mean power [dBm]	Interfering signal mean power [dBm] / BWConfig	Type of interfering signal
1.4	FRC A2-1 in 3GPP TS 36.104 [8], annex A.2	$-71.3 - \Delta_{\text{OTAREFSENS}}$	$-83.7 - \Delta_{\text{OTAREFSENS}}$	AWGN
3	FRC A2-2 in 3GPP TS 36.104 [8], annex A.2	$-67.4 - \Delta_{\text{OTAREFSENS}}$	$-79.7 - \Delta_{\text{OTAREFSENS}}$	AWGN
5	FRC A2-3 in 3GPP TS 36.104 [8], annex A.2	$-65.2 - \Delta_{\text{OTAREFSENS}}$	$-77.5 - \Delta_{\text{OTAREFSENS}}$	AWGN
10	FRC A2-3 in 3GPP TS 36.104 [8], annex A.2 (NOTE 1) FRC A2-4 in 3GPP TS 36.104 [8], annex A.2 (NOTE 2)	$-65.2 - \Delta_{\text{OTAREFSENS}}$ $-68.3 - \Delta_{\text{OTAREFSENS}}$	$-74.5 - \Delta_{\text{OTAREFSENS}}$	AWGN
15	FRC A2-3 in Annex A.2 (NOTE 1)	$-65.2 - \Delta_{\text{OTAREFSENS}}$	$-72.7 - \Delta_{\text{OTAREFSENS}}$	AWGN
20	FRC A2-3 in 3GPP TS 36.104 [8], annex A.2 (NOTE 1) FRC A2-5 in 3GPP TS 36.104 [8], annex A.2 (NOTE 2)	$-65.2 - \Delta_{\text{OTAREFSENS}}$ $-68.3 - \Delta_{\text{OTAREFSENS}}$	$-71.4 - \Delta_{\text{OTAREFSENS}}$	AWGN
<p>NOTE 1: The wanted signal mean power is the power level of a single instance of the reference measurement channel. This requirement shall be met for each consecutive application of a single instance of FRC A2-3 mapped to disjoint frequency ranges with a width of 25 resource blocks each. This reference measurement channel is not applied for Band 46.</p> <p>NOTE 2: The wanted signal mean power is the power level of a single instance of the reference measurement channel. This requirement shall be met for each single interlace of FRC A2-4 and A2-5. This reference measurement channel is only applied for Band 46.</p>				

## 10.5 OTA Adjacent channel selectivity, general blocking, and narrowband blocking

### 10.5.1 General

The adjacent channel selectivity (ACS), general blocking and narrowband blocking characteristics are measures of the receiver unit ability to receive a wanted signal at its assigned channel in the presence of an unwanted interferer inside the operating band.

The requirement applies at the RIB when the AoA of the incident wave of a received signal and the interfering signal are from the same direction, and:

- when the wanted signal is based on  $EIS_{\text{REFSENS}}$  : the AoA of the incident wave of a received signal and the interfering signal are within the OTA  $REFSENS$   $RoAoA$ .
- when the wanted signal is based on  $EIS_{\text{minSENS}}$  : the AoA of the incident wave of a received signal and the interfering signal are within the within the  $minSENS$   $RoAoA$ .

The wanted and interfering signals apply to each supported polarization, under the assumption of *polarization match*.

NOTE: For Single RAT requirements, the in-band selectivity characteristics is referred to as "adjacent channel selectivity", whereas for the MSR requirements, the corresponding property is referred to as "general blocking" since the adjacent frequency range may not carry a channel addressable from the interfered carrier.

The in-band blocking requirement applies from  $F_{UL\_low} - \Delta f_{OOB}$  to  $F_{UL\_high} + \Delta f_{OOB}$ , excluding the downlink frequency range of the FDD *operating band*. The  $\Delta f_{OOB}$  is defined in table 10.5-1.

**Table 10.5-1:  $\Delta f_{OOB}$  offset for operating bands**

<b>Operating band characteristics</b>	<b><math>\Delta f_{OOB}</math> [MHz]</b>
$F_{UL\_high} - F_{UL\_low} < 100$ MHz	20
$100$ MHz $\leq F_{UL\_high} - F_{UL\_low} \leq 900$ MHz	60

## 10.5.2 Minimum requirement for MSR operation

### 10.5.2.1 General minimum requirement

For the general blocking requirement, the interfering signal shall be a UTRA FDD signal as specified in 3GPP TS 37.104 [9], annex A for a UTRA, E-UTRA or NR ( $\leq 20$  MHz) wanted signal. The interfering signal shall be a 20 MHz E-UTRA signal for NR wanted signal channel bandwidth greater than 20MHz.

The requirement is applicable outside the *Base Station RF Bandwidth* or *Radio Bandwidth*. The interfering signal offset is defined relative to the *Base Station RF Bandwidth edges* or *Radio Bandwidth edges* applicable to each RIB.

For RIB supporting operation in *non-contiguous spectrum*, the requirement applies in addition inside any *sub-block gap*, in case the *sub-block gap* size is at least 15 MHz. The interfering signal offset is defined relative to the *sub-block edges* inside the *sub-block gap*.

For *multi-band RIBs*, the requirement applies in addition inside any *Inter RF Bandwidth gap*, in case the gap size is at least 15 MHz. The interfering signal offset is defined relative to the *Base Station RF Bandwidth edges* inside the *Inter RF Bandwidth gap*.

For the wanted and interfering signal at the RIB, using the parameters in tables 7.4.2.1-1 and 7.4.2.1-2, the following requirements shall be met:

- For any E-UTRA carrier, the throughput shall be  $\geq 95$  % of the *maximum throughput* of the reference measurement channel defined in 3GPP TS 36.104 [8], subclause 7.2.1.
- For any UTRA FDD carrier, the BER shall not exceed 0,001 for the reference measurement channel defined in 3GPP TS 25.104 [6], subclause 7.2.1.
- For any NR carrier, the throughput shall be  $\geq 95$ % of the maximum throughput of the reference measurement channel defined for *BS type 1-O* in TS 38.104 [28], subclause 10.3.2

The OTA levels are applied referenced to 2 antenna gain offsets  $\Delta_{OTAREFSENS}$  and  $\Delta_{minSENS}$ .

For *multi-band RIBs*, the requirement applies according to table 10.5.2.1-1 for the in-band blocking frequency ranges of each supported operating band.

Table 10.5.2.1-1: General blocking requirement

Base Station Type	Mean power of interfering signal [dBm]	Wanted Signal mean power [dBm] (NOTE 1)	Centre Frequency of Interfering Signal	Interfering signal centre frequency minimum offset from the <i>Base Station RF Bandwidth edge</i> or <i>edge of sub-block</i> inside a gap [MHz]
Wide Area BS	$-40 + y - \Delta_{\text{OTAREFSENS}}$ (NOTE 7)	$\text{EIS}_{\text{REFSENS}} + x$ dB (NOTE 2, 5)	$F_{\text{UL\_low}} - \Delta f_{\text{OOB}}$ to $F_{\text{UL\_high}} + \Delta f_{\text{OOB}}$	$(\pm 7.5 + z)$ (NOTE 9)
	$-40 + y - \Delta_{\text{minSENS}}$ (NOTE 7)	$\text{EIS}_{\text{minSENS}} + x$ dB (NOTE 2, 5)		
Medium Range BS	$-35 + y - \Delta_{\text{OTAREFSENS}}$ (NOTE 7)	$\text{EIS}_{\text{REFSENS}} + x$ dB (NOTE 3, 5)		
	$-35 + y - \Delta_{\text{minSENS}}$ (NOTE 7)	$\text{EIS}_{\text{minSENS}} + x$ dB (NOTE 3, 5)		
Local Area BS	$-30 + y - \Delta_{\text{OTAREFSENS}}$ (NOTE 7)	$\text{EIS}_{\text{REFSENS}} + x$ dB (NOTE 4, 5)		
	$-30 + y - \Delta_{\text{minSENS}}$ (NOTE 7)	$\text{EIS}_{\text{minSENS}} + x$ dB (NOTE 4, 5)		
<p>NOTE 1: <math>\text{EIS}_{\text{REFSENS}}</math> and <math>\text{EIS}_{\text{minSENS}}</math> depend on the RAT, the BS class and on the <i>channel bandwidth</i>, see subclauses 10.3 and 10.2.</p> <p>NOTE 2: For WA BS supporting UTRA, "x" is equal to 6 in case of NR or E-UTRA or UTRA wanted signals.</p> <p>NOTE 3: For MR BS supporting UTRA, "x" is equal to 6 in case of UTRA wanted signals, 9 in case of NR or E-UTRA wanted signal.</p> <p>NOTE 4: For LA BS supporting UTRA, "x" is equal to 11 in case of NR or E-UTRA wanted signal, 6 in case of UTRA wanted signal.</p> <p>NOTE 5: For a BS not supporting UTRA, x is equal to 6 for all BS classes if NR is supported, otherwise "x" is equal to 6 for WA BS or 9 for MR BS or 11 for LA BS if NR is not supported.</p> <p>NOTE 6: For a BS capable of multi-band operation, "x" in Note 2, 3, 4, 5 applies in case of interfering signals that are in the in-band blocking frequency range of the operating band where the wanted signal is present or in the in-band blocking frequency range of an adjacent or overlapping operating band. For other in-band blocking frequency ranges of the interfering signal for the supported operating bands, "x" is equal to 1.4 dB.</p> <p>NOTE 7: For a BS that supports NR but does not support UTRA, "y" is equal to -3 for the WA and MR BS class and -5 for the LA BS class. For all other cases, "y" is equal to zero for all BS classes.</p> <p>NOTE 8: The downlink frequency range of an FDD operating band is excluded from the general blocking requirement.</p> <p>NOTE 9: For NR wanted signal channel bandwidth greater than 20 MHz, <math>z = 22.5</math>. For all other cases, <math>z = 0</math>.</p>				

Table 10.5.2.1-2: (Void)

NOTE: The requirement in table 10.5.2.1-1 assumes that two operating bands, where the *downlink operating band* (see subclause 4.5 in 3GPP TS 37.104 [9]) of one band would be within the in-band blocking region of the other band, are not deployed in the same geographical area.

### 10.5.2.2 General narrowband blocking minimum requirement

For the general narrowband blocking requirement, the interfering signal shall be an E-UTRA 1RB signal as specified in 3GPP TS 37.104 [9], annex A.

The requirement is applicable outside the *Base Station RF Bandwidth* or *Radio Bandwidth*. The interfering signal offset is defined relative to the *Base Station RF Bandwidth edges* or *Radio Bandwidth edges*.

For RIBs supporting operation in *non-contiguous spectrum*, the requirement applies in addition inside any *sub-block gap*, in case the *sub-block gap* size is at least 3 MHz. The interfering signal offset is defined relative to the *sub-block edges* inside the *sub-block gap*.

For *multi-band RIBs*, the requirement applies in addition inside any *Inter RF Bandwidth gap*, in case the gap size is at least 3 MHz. The interfering signal offset is defined relative to the *Base Station RF Bandwidth edges* inside the *Inter RF Bandwidth gap*.

For the wanted and interfering signal at the RIB using the parameters in table 10.5.2.2-1, the following requirements shall be met:

- For any E-UTRA carrier, the throughput shall be  $\geq 95$  % of the *maximum throughput* of the reference measurement channel defined in 3GPP TS 36.104 [8], subclause 7.2.1.
- For any UTRA FDD carrier, the BER shall not exceed 0,001 for the reference measurement channel defined in 3GPP TS 25.104 [6], subclause 7.2.1.
- For any NR carrier, the throughput shall be  $\geq 95$  % of the maximum throughput of the reference measurement channel defined for *BS type 1-O* in TS 38.104 [28], subclause 10.3.2

**Table 10.5.2.2-1: Narrowband blocking requirement**

Base Station Type	RAT of the carrier	Wanted signal mean power [dBm] (NOTE 1, 2, 6)	Interfering signal mean power [dBm]	Interfering RB (NOTE 3) centre frequency offset from the AAS Base Station RF Bandwidth edge or edge of sub-block inside a gap [kHz]
Wide Area BS	E-UTRA, UTRA, NR	$EIS_{REFSENS} + x$ dB	$-49 - \Delta_{OTAREFSENS}$	$\pm(240 + m \cdot 180)$ , $m=0, 1, 2, 3, 4, 9, 14$ (Note 4)
		$EIS_{minSENS} + x$ dB	$-49 - \Delta_{minSENS}$	
Medium Range BS		$EIS_{REFSENS} + x$ dB	$-44 - \Delta_{OTAREFSENS}$	
		$EIS_{minSENS} + x$ dB	$-44 - \Delta_{minSENS}$	
Local Area BS		$EIS_{REFSENS} + x$ dB	$-41 - \Delta_{OTAREFSENS}$	$\pm(550 + m \cdot 180)$ , $m=0, 1, 2, 3, 4, 29, 54, 79, 99$ (Note 5)
		$EIS_{minSENS} + x$ dB	$-41 - \Delta_{minSENS}$	
NOTE 1: $EIS_{REFSENS}$ and $EIS_{minSENS}$ depend on the RAT, the BS class and on the <i>channel bandwidth</i> , see subclauses 10.3 and 10.2.				
NOTE 2: "x" is equal to 6 dB in case of E-UTRA or UTRA or NR wanted signals.				
NOTE 3: Interfering signal (E-UTRA 3 MHz) consisting of one resource block positioned at the stated offset, the <i>channel bandwidth</i> of the interfering signal is located adjacently to the AAS <i>Base Station RF Bandwidth edge</i> .				
NOTE 4: Applicable for <i>channel bandwidths</i> equal to or below 20 MHz.				
NOTE 5: Applicable for <i>channel bandwidths</i> above 20 MHz.				
NOTE 6: 7.5 kHz shift is not applied to the wanted signal of NR.				
NOTE 7: Void				

### 10.5.2.3 Additional BC3 blocking minimum requirement

This additional requirement only applies for BS operating in the same geographical area as UTRA TDD.

For the additional BC3 blocking requirement, the interfering signal is a 1,28 Mcps UTRA TDD signal as specified in 3GPP TS 37.104 [9], annex A.

The requirement is always applicable outside the *Base Station RF Bandwidth* or *Radio Bandwidth*. The interfering signal offset is defined relative to the *Base Station RF Bandwidth edges* or *Radio Bandwidth edges*.

For *multi-band RIBs*, the requirement applies in addition inside any *Inter RF Bandwidth gap*, in case the gap size is at least 4.8 MHz. The interfering signal offset is defined relative to the *Base Station RF Bandwidth edges* inside the *Inter RF Bandwidth gap*.

For the wanted and interfering signal at the RIB, using the parameters in table 10.5.2.3-1, the following requirements shall be met:

- For any E-UTRA TDD carrier, the throughput shall be  $\geq 95$  % of the *maximum throughput* of the reference measurement channel defined in 3GPP TS 36.104 [8], subclause 7.2.1.

Table 10.5.2.3-1: Additional blocking requirement for BC3

Operating Band	Centre Frequency of Interfering Signal [MHz]	Interfering Signal mean power [dBm]	Wanted Signal mean power [dBm] (NOTE)	Interfering signal centre frequency minimum offset from the Base Station RF Bandwidth edge [MHz]
33 - 39	(F <sub>UL_low</sub> - 20) to (F <sub>UL_high</sub> + 20)	-40 - $\Delta_{OTAREFSENS}$	EIS <sub>REFSENS</sub> + 6 dB	±2,4
		-40 - $\Delta_{minSENS}$	EIS <sub>minSENS</sub> + 6 dB	
40	(F <sub>UL_low</sub> - 60) to (F <sub>UL_high</sub> + 60)	-40 - $\Delta_{OTAREFSENS}$	EIS <sub>REFSENS</sub> + 6 dB	±2,4
		-40 - $\Delta_{minSENS}$	EIS <sub>minSENS</sub> + 6 dB	
NOTE: EIS <sub>REFSENS</sub> and EIS <sub>minSENS</sub> depend on the RAT, the BS class and on the <i>channel bandwidth</i> , see subclauses 10.3 and 10.2.				

### 10.5.3 Minimum requirement for single RAT UTRA operation

#### 10.5.3.1 General

Adjacent channel selectivity (ACS) is a measure of the receiver ability to receive a wanted signal at its assigned channel frequency in the presence of an adjacent channel signal at a given frequency offset from the centre frequency of the assigned channel. ACS is the ratio of the receiver filter attenuation on the assigned channel frequency to the receiver filter attenuation on the adjacent channel(s).

The interference signal is offset from the wanted signal by the frequency offset  $F_{uw}$ . The interference signal shall be a W-CDMA signal as specified in 3GPP TS 25.104 [6] Annex C.

For RIBs supporting operation in *non-contiguous spectrum*, the requirement applies in addition inside any *sub-block gap*, in case the *sub-block gap* size is at least 5 MHz. The interfering signal offset is defined relative to the *sub-block* edges inside the *sub-block gap* and is equal to -2.5MHz/+2.5MHz, respectively.

For *multi-band RIBs*, the requirement applies in addition inside any *Inter RF Bandwidth gap* at the RIB, in case the gap size is at least 5 MHz. The interfering signal offset is defined relative to the *Base Station RF Bandwidth edges* inside the *Inter RF Bandwidth gap* and is equal to -2.5MHz/+2.5MHz, respectively.

The OTA levels are applied referenced to  $\Delta_{minSENS}$ .

#### 10.5.3.2 Minimum requirement

The BER shall not exceed 0.001 for the parameters specified in table 10.5.3.2-1.

Table 10.5.3.2-1: Adjacent channel selectivity

Parameter	Level Wide Area BS	Level Medium Range BS	Level Local Area / Home BS	Unit
Data rate	12.2	12.2	12.2	kbps
Wanted signal mean power	-115 - $\Delta_{minSENS}$	-105 - $\Delta_{minSENS}$	-101 - $\Delta_{minSENS}$	dBm
Interfering signal mean power	-52 - $\Delta_{minSENS}$	-42 - $\Delta_{minSENS}$	-38 - $\Delta_{minSENS}$	dBm
$F_{uw}$ offset (Modulated)	±5	±5	±5	MHz

#### 10.5.3.3 Minimum requirement - Co-location with UTRA-TDD

The current state-of-the-art technology does not allow a single generic solution for co-location with UTRA-TDD on adjacent frequencies for 30dB BS-BS minimum coupling loss.

Further information and analysis for this scenario can be found in TR 25.942 [12].

## 10.5.4 Minimum requirement for single RAT E-UTRA operation

### 10.5.4.1 General

Adjacent channel selectivity (ACS) is a measure of the receiver ability to receive a wanted signal at its assigned channel frequency in the presence of an adjacent channel signal with a specified centre frequency offset of the interfering signal to the band edge of a victim system. For E-UTRA *OTA AAS BS*, the interfering signal shall be an E-UTRA signal as specified in 3GPP TS 36.104 [8] Annex C.

### 10.5.4.2 Minimum requirement

The throughput shall be  $\geq 95\%$  of the *maximum throughput* of the reference measurement channel.

For E-UTRA Wide Area BS, the wanted and the interfering signal coupled to the BS antenna input are specified in tables 10.5.4.2-1 and 10.5.4.2-2 for narrowband blocking and in table 10.5.4.2-3 for ACS. The reference measurement channel for the wanted signal is identified in table 10.3.4-1 for each *channel bandwidth* and further specified in 3GPP TS 36.104 [8] Annex A.

For E-UTRA Medium Range BS, the wanted and the interfering signal coupled to the BS antenna input are specified in tables 10.5.4.2-1 and 10.5.4.2-2 for narrowband blocking and in table 10.5.4.2-6 for ACS. Narrowband blocking requirements are not applied for Band 46. The reference measurement channel for the wanted signal is identified in table 10.3.4-3 for each *channel bandwidth* and further specified in 3GPP TS 36.104 [8] Annex A.

For E-UTRA Local Area BS, the wanted and the interfering signal coupled to the BS antenna input are specified in tables 10.5.4.2-1 and 10.5.4.2-2 for narrowband blocking and in table 10.5.4.2-4 for ACS. Narrowband blocking requirements are not applied for Band 46 nor for Band 49. The reference measurement channel for the wanted signal is identified in table 10.3.4-2 for each *channel bandwidth* and further specified in 3GPP TS 36.104 [8] Annex A.

For narrowband blocking the OTA levels are applied referenced to 2 antenna gain offsets  $\Delta_{\text{OTAREFSENS}}$  and  $\Delta_{\text{minSENS}}$ .

For ACS the OTA levels are applied referenced to  $\Delta_{\text{minSENS}}$ .

The ACS and narrowband blocking requirement is applicable outside the *Base Station RF Bandwidth* or *Radio Bandwidth*. The interfering signal offset is defined relative to the *Base station RF Bandwidth edges* or *Radio Bandwidth edges*.

For RIBs supporting operation in *non-contiguous spectrum* within any operating band, the ACS requirement applies in addition inside any *sub-block gap*, in case the *sub-block gap* size is at least as wide as the E-UTRA interfering signal in table 10.5.4.2-3, 10.5.4.2-4 and 10.5.4.2-5. The interfering signal offset is defined relative to the *sub-block edges* inside the *sub-block gap*.

For *multi-band RIBs*, the ACS requirement applies in addition inside any *Inter RF Bandwidth gap* at the RIB, in case the gap size is at least as wide as the E-UTRA interfering signal in table 10.5.4.2-3, 10.5.4.2-4 and 10.5.4.2-5. The interfering signal offset is defined relative to the *Base Station RF Bandwidth edges* inside the *Inter RF Bandwidth gap*.

For a RIBs operating in *non-contiguous spectrum* within any operating band, the narrowband blocking requirement applies in addition inside any *sub-block gap*, in case the *sub-block gap* size is at least as wide as the *channel bandwidth* of the E-UTRA interfering signal in table 10.5.4.2-2. The interfering signal offset is defined relative to the *sub-block edges* inside the *sub-block gap*.

For *multi-band RIBs*, the narrowband blocking requirement applies in addition inside any *Inter RF Bandwidth gap*, in case the *Inter RF Bandwidth gap* size is at least as wide as the E-UTRA interfering signal in table 10.5.4.2-2. The interfering signal offset is defined relative to the *Base Station RF Bandwidth edges* inside the *Inter RF Bandwidth gap*.

**Table 10.5.4.2-1: Narrowband blocking requirement for E-UTRA BS**

	Wanted signal mean power [dBm] (NOTE)	Interfering signal mean power [dBm]	Type of interfering signal
Wide Area BS	$EIS_{REFSENS} + 6dB$	$-49 - \Delta_{OTAREFSSENS}$	See table 10.5.4.2-2
	$EIS_{minSENS} + 6dB$	$-49 - \Delta_{minSENS}$	
Medium Range BS	$EIS_{REFSENS} + 6dB$	$-44 - \Delta_{OTAREFSSENS}$	See table 10.5.4.2-2
	$EIS_{minSENS} + 6dB$	$-44 - \Delta_{minSENS}$	
Local Area BS	$EIS_{REFSENS} + 6dB$	$-41 - \Delta_{OTAREFSSENS}$	See table 10.5.4.2-2
	$EIS_{minSENS} + 6dB$	$-41 - \Delta_{minSENS}$	
NOTE: $EIS_{REFSENS}$ and $EIS_{minSENS}$ depend on the RAT, the BS class and on the <i>channel bandwidth</i> , see subclauses 10.3 and 10.2.			

**Table 10.5.4.2-2: Interfering signal for Narrowband blocking requirement for E-UTRA BS**

E-UTRA channel BW of the lowest/highest carrier received [MHz]	Interfering RB centre frequency offset to the lower/upper Base Station RF Bandwidth edge or sub-block edge inside a <i>sub-block gap</i> [kHz]	Type of interfering signal
1.4	$\pm(252.5+m*180)$ , $m=0, 1, 2, 3, 4, 5$	1.4 MHz E-UTRA signal, 1 RB (NOTE)
3	$\pm(247.5+m*180)$ , $m=0, 1, 2, 3, 4, 7, 10, 13$	3 MHz E-UTRA signal, 1 RB (NOTE)
5	$\pm(342.5+m*180)$ , $m=0, 1, 2, 3, 4, 9, 14, 19, 24$	5 MHz E-UTRA signal, 1 RB (NOTE)
10	$\pm(347.5+m*180)$ , $m=0, 1, 2, 3, 4, 9, 14, 19, 24$	5 MHz E-UTRA signal, 1 RB (NOTE)
15	$\pm(352.5+m*180)$ , $m=0, 1, 2, 3, 4, 9, 14, 19, 24$	5 MHz E-UTRA signal, 1 RB (NOTE)
20	$\pm(342.5+m*180)$ , $m=0, 1, 2, 3, 4, 9, 14, 19, 24$	5 MHz E-UTRA signal, 1 RB (NOTE)
NOTE: Interfering signal consisting of one resource block is positioned at the stated offset, the <i>channel bandwidth</i> of the interfering signal is located adjacently to the lower/upper <i>Base Station RF Bandwidth edge</i> .		

**Table 10.5.4.2-3: Adjacent channel selectivity for E-UTRA Wide Area BS**

E-UTRA channel bandwidth of the lowest/highest carrier received [MHz]	Wanted signal mean power [dBm] (NOTE)	Interfering signal mean power [dBm]	Interfering signal centre frequency offset from the lower/upper Base Station RF Bandwidth edge or sub-block edge inside a <i>sub-block gap</i> [MHz]	Type of interfering signal
1.4	$EIS_{minSENS} + 11dB$	$-52 - \Delta_{minSENS}$	$\pm 0.7025$	1.4MHz E-UTRA signal
3	$EIS_{minSENS} + 8dB$	$-52 - \Delta_{minSENS}$	$\pm 1.5075$	3MHz E-UTRA signal
5	$EIS_{minSENS} + 6dB$	$-52 - \Delta_{minSENS}$	$\pm 2.5025$	5MHz E-UTRA signal
10	$EIS_{minSENS} + 6dB$	$-52 - \Delta_{minSENS}$	$\pm 2.5075$	5MHz E-UTRA signal
15	$EIS_{minSENS} + 6dB$	$-52 - \Delta_{minSENS}$	$\pm 2.5125$	5MHz E-UTRA signal
20	$EIS_{minSENS} + 6dB$	$-52 - \Delta_{minSENS}$	$\pm 2.5025$	5MHz E-UTRA signal
NOTE: $EIS_{minSENS}$ depends on the <i>channel bandwidth</i> as specified see subclause 10.2.				

Table 10.5.4.2-4: Adjacent channel selectivity for E-UTRA Local Area BS

E-UTRA channel bandwidth of the lowest/highest carrier received [MHz]	Wanted signal mean power [dBm] (NOTE 1)	Interfering signal mean power [dBm]	Interfering signal centre frequency offset from the lower/upper Base Station RF Bandwidth edge or sub-block edge inside a sub-block gap [MHz]	Type of interfering signal
1.4	$EIS_{minSENS} + 11\text{dB}$	$-44 - \Delta_{minSENS}$	$\pm 0.7025$	1.4 MHz E-UTRA signal
3	$EIS_{minSENS} + 8\text{dB}$	$-44 - \Delta_{minSENS}$	$\pm 1.5075$	3 MHz E-UTRA signal
5	$EIS_{minSENS} + 6\text{dB}$	$-44 - \Delta_{minSENS}$	$\pm 2.5025$	5 MHz E-UTRA signal
10	$EIS_{minSENS} + 6\text{dB}$	$-44 - \Delta_{minSENS}$	$\pm 2.5075$	5 MHz E-UTRA signal (NOTE 2)
15	$EIS_{minSENS} + 6\text{dB}$	$-44 - \Delta_{minSENS}$	$\pm 2.5125$	5 MHz E-UTRA signal
20	$EIS_{minSENS} + 6\text{dB}$	$-44 - \Delta_{minSENS}$	$\pm 2.5025$	5 MHz E-UTRA signal (NOTE 2)

NOTE 1:  $EIS_{minSENS}$  depends on the *channel bandwidth* as specified see subclause 10.2.  
NOTE 2: This type of interfering signal is not applied for Band 46 nor for Band 49.  
NOTE 3: Void

Table 10.5.4.2-5: Adjacent channel selectivity for E-UTRA Medium Range BS

E-UTRA channel bandwidth of the lowest/highest carrier received [MHz]	Wanted signal mean power [dBm] (NOTE 1)	Interfering signal mean power [dBm]	Interfering signal centre frequency offset to the lower/upper Base Station RF Bandwidth edge or sub-block edge inside a sub-block gap [MHz]	Type of interfering signal
1.4	$EIS_{minSENS} + 11\text{dB}$	$-47 - \Delta_{minSENS}$	$\pm 0.7025$	1.4 MHz E-UTRA signal
3	$EIS_{minSENS} + 8\text{dB}$	$-47 - \Delta_{minSENS}$	$\pm 1.5075$	3 MHz E-UTRA signal
5	$EIS_{minSENS} + 6\text{dB}$	$-47 - \Delta_{minSENS}$	$\pm 2.5025$	5 MHz E-UTRA signal
10	$EIS_{minSENS} + 6\text{dB}$	$-47 - \Delta_{minSENS}$	$\pm 2.5075$	5 MHz E-UTRA signal (NOTE 2)
15	$EIS_{minSENS} + 6\text{dB}$	$-47 - \Delta_{minSENS}$	$\pm 2.5125$	5 MHz E-UTRA signal
20	$EIS_{minSENS} + 6\text{dB}$	$-47 - \Delta_{minSENS}$	$\pm 2.5025$	5 MHz E-UTRA signal (NOTE 2)

NOTE 1:  $EIS_{minSENS}$  depends on the *channel bandwidth* as specified see subclause 10.2.  
NOTE 2: This type of interfering signal is not applied for Band 46 nor for Band 49.  
NOTE 3: Void

## 10.6 OTA Blocking

### 10.6.1 General

The blocking characteristics are a measure of the receiver unit ability to receive a wanted signal at the RIB at its assigned channel in the presence of an unwanted interferer.

The requirement applies at the *RIB* when the AoA of the incident wave of the received signal and the interfering signal are the same direction and are within the *minSENS RoAoA*

The wanted signal applies to each supported polarization, under the assumption of *polarization match*. The interferer shall be polarization matched in-band and the polarization maintained for out-of-band frequencies.

The out-of-band blocking requirement applies from 30 MHz to  $F_{UL\_low} - \Delta f_{OOB}$  and from  $F_{UL\_high} + \Delta f_{OOB}$  up to 12750 MHz, including the downlink frequency range of the FDD *operating band* for BS supporting FDD.  $\Delta f_{OOB}$  is defined in table 10.5-1.

## 10.6.2 Minimum requirement for MSR operation

### 10.6.2.1 General minimum requirement

The OTA interfering signal RMS field-strength shall be set to 0.36 V/m at the RIB.

NOTE: The RMS field-strength level in V/m is related to the interferer EIRP level at a distance described as

$$E = \frac{\sqrt{30EIRP}}{r}$$

, where EIRP is in W and r is in m; for example, 0.36 V/m is equivalent to 36 dBm at fixed distance of 30 m.

For a wanted and an interfering signal coupled to the RIB using the parameters in table 10.6.2.1-1, the following requirements shall be met:

- For any E-UTRA carrier, the throughput shall be  $\geq 95$  % of the *maximum throughput* of the reference measurement channel defined in 3GPP TS 36.104 [8], subclause 7.2.1.
- For any UTRA FDD carrier, the BER shall not exceed 0.001 for the reference measurement channel defined in 3GPP TS 25.104 [6], subclause 7.2.1.
- For any NR carrier, the throughput shall be  $\geq 95$ % of the maximum throughput of the reference measurement channel defined for *BS type 1-O* in TS 38.104 [28], subclause 10.3.2.

For *multi-band RIB*, the requirement applies for each supported operating band. The in-band blocking frequency ranges of all supported operating bands according to table 10.6.2.1-1 shall be excluded from the requirement.

**Table 10.6.2.1-1: Blocking performance requirement**

Interfering Signal mean power	Wanted Signal mean power [dBm]	Type of Interfering Signal
0.36 V/m	EIS <sub>minSENS</sub> +X dB (NOTE 1)	CW carrier
NOTE 1: EIS <sub>minSENS</sub> depends on the RAT, the BS class and the channel bandwidth, see subclause 7.2. "x" is equal to 6 in case of NR, E-UTRA or UTRA wanted signals.		

### 10.6.2.2 Co-location minimum requirement

This additional blocking requirement may be applied for the protection of *AAS BS receivers* when E-UTRA BS, NR BS, UTRA BS, CDMA BS or GSM/EDGE BS operating in a different frequency band are co-located with an AAS BS.

The requirement is a co-location requirement. The interferer power levels are specified at the *co-location reference antenna* conducted input. The interfering power is specified per supported polarization.

The requirement is valid over *minSENS RoAoA*.

When the wanted and an interfering signal using the parameters in table 10.6.2.2-1, the following requirements shall be met:

- For any E-UTRA carrier, the throughput shall be  $\geq 95$  % of the *maximum throughput* of the reference measurement channel defined in 3GPP TS 36.104 [8], subclause 7.2.1.
- For any UTRA FDD carrier, the BER shall not exceed 0,001 for the reference measurement channel defined in 3GPP TS 25.104 [6], subclause 7.2.1.

**Table 10.6.2.2-1: OTA Blocking requirement for co-location with BS in other frequency bands**

Type of co-located BS	Centre Frequency of Interfering Signal [MHz]	Interfering Signal mean power for WA BS [dBm]	Interfering Signal mean power for MR BS [dBm]	Interfering Signal mean power for LA BS [dBm]	Wanted Signal mean power [dBm]	Type of Interfering Signal
GSM850 or CDMA850	869 - 894	+46	+38	+24	$EIS_{\min SENS} + x$ dB (NOTE 1)	CW carrier
GSM900	921 - 960	+46	+38	+24	$EIS_{\min SENS} + x$ dB (NOTE 1)	CW carrier
DCS1800	1805 - 1880 (NOTE 4)	+46	+38	+24	$EIS_{\min SENS} + x$ dB (NOTE 1)	CW carrier
PCS1900	1930 - 1990	+46	+38	+24	$EIS_{\min SENS} + x$ dB (NOTE 1)	CW carrier
UTRA FDD Band I or E-UTRA Band 1 or NR band n1	2110 - 2170	+46	+38	+24	$EIS_{\min SENS} + x$ dB (NOTE 1)	CW carrier
UTRA FDD Band II or E-UTRA Band 2 or NR band n2	1930 - 1990	+46	+38	+24	$EIS_{\min SENS} + x$ dB (NOTE 1)	CW carrier
UTRA FDD Band III or E-UTRA Band 3 or NR band n3	1805 - 1880 (NOTE 4)	+46	+38	+24	$EIS_{\min SENS} + x$ dB (NOTE 1)	CW carrier
UTRA FDD Band IV or E-UTRA Band 4	2110 - 2155	+46	+38	+24	$EIS_{\min SENS} + x$ dB (NOTE 1)	CW carrier
UTRA FDD Band V or E-UTRA Band 5 or NR band n5	869 - 894	+46	+38	+24	$EIS_{\min SENS} + x$ dB (NOTE 1)	CW carrier
UTRA FDD Band VI or E-UTRA Band 6	875 - 885	+46	+38	+24	$EIS_{\min SENS} + x$ dB (NOTE 1)	CW carrier
UTRA FDD Band VII or E-UTRA Band 7 or NR band n7	2620 - 2690	+46	+38	+24	$EIS_{\min SENS} + x$ dB (NOTE 1)	CW carrier
UTRA FDD Band VIII or E-UTRA Band 8 or NR band n8	925 - 960	+46	+38	+24	$EIS_{\min SENS} + x$ dB (NOTE 1)	CW carrier
UTRA FDD Band IX or E-UTRA Band 9	1844.9 - 1879.9	+46	+38	+24	$EIS_{\min SENS} + x$ dB (NOTE 1)	CW carrier
UTRA FDD Band X or E-UTRA Band 10	2110 - 2170	+46	+38	+24	$EIS_{\min SENS} + x$ dB (NOTE 1)	CW carrier
UTRA FDD Band XI or E-UTRA Band 11	1475.9 - 1495.9	+46	+38	+24	$EIS_{\min SENS} + x$ dB (NOTE 1)	CW carrier
UTRA FDD Band XII or E-UTRA Band 12 or NR band n12	729 - 746	+46	+38	+24	$EIS_{\min SENS} + x$ dB (NOTE 1)	CW carrier
UTRA FDD Band XIII or E-UTRA Band 13 or NR band n13	746 - 756	+46	+38	+24	$EIS_{\min SENS} + x$ dB (NOTE 1)	CW carrier
UTRA FDD Band XIV or E-UTRA Band 14 or NR band n14	758 - 768	+46	+38	+24	$EIS_{\min SENS} + x$ dB (NOTE 1)	CW carrier
E-UTRA Band 17	734 - 746	+46	+38	+24	$EIS_{\min SENS} + x$ dB (NOTE 1)	CW carrier
E-UTRA Band 18 or NR Band n18	860 - 875	+46	+38	+24	$EIS_{\min SENS} + x$ dB (NOTE 1)	CW carrier
UTRA FDD Band XIX or E-UTRA Band 19	875 - 890	+46	+38	+24	$EIS_{\min SENS} + x$ dB (NOTE 1)	CW carrier
UTRA FDD Band XX or E-UTRA Band 20 or NR band 20	791 - 821	+46	+38	+24	$EIS_{\min SENS} + x$ dB (NOTE 1)	CW carrier
UTRA FDD Band XXI or E-UTRA Band 21	1495.9 - 1510.9	+46	+38	+24	$EIS_{\min SENS} + x$ dB (NOTE 1)	CW carrier
UTRA FDD Band XXII or E-UTRA Band 22	3510 - 3 590	+46	+38	+24	$EIS_{\min SENS} + x$ dB (NOTE 1)	CW carrier
E-UTRA Band 24 or NR band n24	1525 - 1559	+46	+38	+24	$EIS_{\min SENS} + x$ dB (NOTE 1)	CW carrier

Type of co-located BS	Centre Frequency of Interfering Signal [MHz]	Interfering Signal mean power for WA BS [dBm]	Interfering Signal mean power for MR BS [dBm]	Interfering Signal mean power for LA BS [dBm]	Wanted Signal mean power [dBm]	Type of Interfering Signal
UTRA FDD Band XXV or E-UTRA Band 25 or NR band n25	1930 - 1995	+46	+38	+24	$EIS_{minSENS} + x$ dB (NOTE 1)	CW carrier
UTRA FDD Band XXVI or E-UTRA Band 26 or NR band n26	859 - 894	+46	+38	+24	$EIS_{minSENS} + x$ dB (NOTE 1)	CW carrier
E-UTRA Band 27	852 - 869	+46	+38	+24	$EIS_{minSENS} + x$ dB (NOTE 1)	CW carrier
E-UTRA Band 28 or or NR band n28	758 - 803	+46	+38	+24	$EIS_{minSENS} + x$ dB (NOTE 1)	CW carrier
E-UTRA Band 29 or NR Band n29	717 - 728	+46	+38	+24	$EIS_{minSENS} + x$ dB (NOTE 1)	CW carrier
E-UTRA Band 30 or NR band n30	2350 - 2360	+46	+38	+24	$EIS_{minSENS} + x$ dB (NOTE 1)	CW carrier
E-UTRA Band 31	462.5 - 467.5	+46	+38	+24	$EIS_{minSENS} + x$ dB (NOTE 1)	CW carrier
E-UTRA Band 31	462.5 - 467.5	+46	+38	+24	$EIS_{minSENS} + x$ dB (NOTE 1)	CW carrier
UTRA FDD Band XXXII or E-UTRA Band 32	1452 - 1496 (NOTE-5)	+46	+38	+24	$EIS_{minSENS} + x$ dB (NOTE 1)	CW carrier
UTRA TDD Band a) or E-UTRA TDD Band 33	1900 - 1920	+46	+38	+24	$EIS_{minSENS} + x$ dB (NOTE 1)	CW carrier
UTRA TDD Band a) or E-UTRA TDD Band 34 or NR band n34	2010 - 2025	+46	+38	+24	$EIS_{minSENS} + x$ dB (NOTE 1)	CW carrier
UTRA TDD Band b) or E-UTRA TDD Band 35	1850 - 1910	+46	+38	+24	$EIS_{minSENS} + x$ dB (NOTE 1)	CW carrier
UTRA TDD Band b) or E-UTRA TDD Band 36	1930 - 1990	+46	+38	+24	$EIS_{minSENS} + x$ dB (NOTE 1)	CW carrier
UTRA TDD Band c) or E-UTRA TDD Band 37	1910 - 1930	+46	+38	+24	$EIS_{minSENS} + x$ dB (NOTE 1)	CW carrier
UTRA TDD Band d) or E-UTRA Band 38 or NR band n38	2570 - 2620	+46	+38	+24	$EIS_{minSENS} + x$ dB (NOTE 1)	CW carrier
UTRA TDD Band f) or E-UTRA Band 39 or NR band n39	1880 - 1920	+46	+38	+24	$EIS_{minSENS} + x$ dB (NOTE 1)	CW carrier
UTRA TDD Band e) or E-UTRA Band 40 or NR band n40	2300 - 2400	+46	+38	+24	$EIS_{minSENS} + x$ dB (NOTE 1)	CW carrier
E-UTRA Band 41 or NR band n41	2496 - 2690	+46	+38	+24	$EIS_{minSENS} + x$ dB (NOTE 1)	CW carrier
E-UTRA Band 42	3400 - 3600	+46	+38	+24	$EIS_{minSENS} + x$ dB (NOTE 1)	CW carrier
E-UTRA Band 43	3600 - 3800	+46	+38	+24	$EIS_{minSENS} + x$ dB (NOTE 1)	CW carrier
E-UTRA Band 44	703 - 803	+46	+38	+24	$EIS_{minSENS} + x$ dB (NOTE 1)	CW carrier
E-UTRA Band 45	1447 - 1467	+46	+38	+24	$EIS_{minSENS} + x$ dB (NOTE 1)	CW carrier
E-UTRA Band 46 or NR Band n46	5150 - 5925	N/A	+38	+24	$EIS_{minSENS} + x$ dB (NOTE 1)	CW carrier
E-UTRA Band 48 or NR Band n48	3550 - 3700	+46	+38	+24	$EIS_{minSENS} + x$ dB (NOTE 1)	CW carrier

Type of co-located BS	Centre Frequency of Interfering Signal [MHz]	Interfering Signal mean power for WA BS [dBm]	Interfering Signal mean power for MR BS [dBm]	Interfering Signal mean power for LA BS [dBm]	Wanted Signal mean power [dBm]	Type of Interfering Signal
E-UTRA Band 49	3550 – 3700	N/A	N/A	+24	$EIS_{minSENS} + x$ dB (NOTE 1)	CW carrier
E-UTRA Band 50 or NR band n50	1432 – 1517	+46	+38	+24	$EIS_{minSENS} + x$ dB (NOTE 1)	CW carrier
E-UTRA Band 51 or or NR band n51	1427– 1432	N/A	N/A	+24	$EIS_{minSENS} + x$ dB (NOTE 1)	CW carrier
E-UTRA Band 52	3300 - 3400	+46	+38	+24	$EIS_{minSENS} + x$ dB (NOTE 1)	CW carrier
E-UTRA Band 53 or NR band n53	2483.5 - 2495	N/A	+38	+24	$EIS_{minSENS} + x$ dB (NOTE 1)	CW carrier
E-UTRA Band 65 or NR band n65	2110 – 2200	+46	+38	+24	$EIS_{minSENS} + x$ dB (NOTE 1)	CW carrier
E-UTRA Band 66 or or NR band n66	2110 – 2200	+46	+38	+24	$EIS_{minSENS} + x$ dB (NOTE 1)	CW carrier
E-UTRA Band 67 or NR band n67	738 - 758	+46	+38	+24	$EIS_{minSENS} + x$ dB (NOTE 1)	CW carrier
E-UTRA Band 68	753 - 783	+46	+38	+24	$EIS_{minSENS} + x$ dB (NOTE 1)	CW carrier
E-UTRA Band 69	2570-2620	+46	+38	+24	$EIS_{minSENS} + x$ dB (NOTE 1)	CW carrier
E-UTRA Band 70 or or NR band n70	1995 - 2020	+46	+38	+24	$EIS_{minSENS} + x$ dB (NOTE 1)	CW carrier
E-UTRA Band 71 or or NR band n71	617 - 652	+46	+38	+24	$EIS_{minSENS} + x$ dB (NOTE 1)	CW carrier
E-UTRA Band 72	461 - 466	+46	+38	+24	$EIS_{minSENS} + x$ dB (NOTE 1)	CW carrier
E-UTRA Band 73	460 - 465	+46	+38	+24	$EIS_{minSENS} + x$ dB (NOTE 1)	CW carrier
E-UTRA Band 74 or NR band n74	1475 - 1518	+46	+38	+24	$EIS_{minSENS} + x$ dB (NOTE 1)	CW carrier
E-UTRA Band 75 or or NR band n75	1432 - 1517	+46	+38	+24	$EIS_{minSENS} + x$ dB (NOTE 1)	CW carrier
E-UTRA Band 76 or or NR band n76	1427 - 1432	N/A	N/A	+24	$EIS_{minSENS} + x$ dB (NOTE 1)	CW carrier
NR band n77	3300 - 4200	+46	+38	+24	$EIS_{minSENS} + x$ dB (NOTE 1)	CW carrier
NR band n78	3300 - 3800	+46	+38	+24	$EIS_{minSENS} + x$ dB (NOTE 1)	CW carrier
NR band n79	4400 - 5000	+46	+38	+24	$EIS_{minSENS} + x$ dB (NOTE 1)	CW carrier
E-UTRA Band 85 or or NR band n85	728 - 746	+46	+38	+24	$EIS_{minSENS} + x$ dB (NOTE 1)	CW carrier
E-UTRA Band 87	420 - 425	+46	+38	+24	$EIS_{minSENS} + x$ dB (NOTE 1)	CW carrier
E-UTRA Band 88	422 - 427	+46	+38	+24	$EIS_{minSENS} + x$ dB (NOTE 1)	CW carrier
NR band n91	1427 - 1432	N/A	N/A	+24	$EIS_{minSENS} + x$ dB (NOTE 1)	CW carrier
NR band n92	1432 - 1517	+46	+38	+24	$EIS_{minSENS} + x$ dB (NOTE 1)	CW carrier
NR band n93	1427 - 1432	N/A	N/A	+24	$EIS_{minSENS} + x$ dB (NOTE 1)	CW carrier
NR band n94	1432 - 1517	+46	+38	+24	$EIS_{minSENS} + x$ dB (NOTE 1)	CW carrier
NR band n96	5925 - 7125	N/A	+38	+24	$EIS_{minSENS} + x$ dB (NOTE 1)	CW carrier
NR band n102	5925 - 6425	N/A	+38	+24	$EIS_{minSENS} + x$ dB (NOTE 1)	CW carrier
E-UTRA Band 103	757 - 758	+46	+38	+24	$EIS_{minSENS} + x$ dB (NOTE 1)	CW carrier

Type of co-located BS	Centre Frequency of Interfering Signal [MHz]	Interfering Signal mean power for WA BS [dBm]	Interfering Signal mean power for MR BS [dBm]	Interfering Signal mean power for LA BS [dBm]	Wanted Signal mean power [dBm]	Type of Interfering Signal
NOTE 1: $EIS_{\min SENS}$ depends on the RAT, the BS class and on the <i>channel bandwidth</i> , see subclauses 10.3 and 10.2.						
NOTE 2: Except for a BS operating in Band 13, these requirements do not apply when the interfering signal falls within any of the supported <i>uplink operating band</i> or in the $\Delta f_{OOB}$ immediately outside any of the supported <i>uplink operating band</i> . For a BS operating in band 13 the requirements do not apply when the interfering signal falls within the frequency range 768 - 797 MHz.						
NOTE 3: Some combinations of bands may not be possible to co-site based on the requirements above. The current state-of-the-art technology does not allow a single generic solution for co-location of UTRA TDD or E-UTRA TDD or NR TDD with E-UTRA FDD or NR FDD on adjacent frequencies with closely spaced antennas. However, there are certain site-engineering solutions that can be used. These techniques are addressed in 3GPP TR 25.942 [12].						
NOTE 4: In China, the blocking requirement for co-location with DCS1800 and Band III BS is only applicable in the frequency range 1805 - 1850 MHz.						
NOTE 5: For an AAS BS operating in band 11, 21, or 74 the requirement for co-location with Band 32 applies for interfering signal within the frequency range 1475.9 - 1495.9 MHz.						

## 10.6.3 Minimum requirement for single RAT UTRA operation

### 10.6.3.1 General minimum requirement

In addition to the following in-band and narrowband requirements, the general minimum requirements relating to out of band blocking defined for MSR in subclause 10.6.2.1 shall also be applied for single RAT UTRA operation.

The minimum requirement for in-band blocking and narrowband blocking UTRA operation is defined below:

The requirement is applicable outside the *Base Station RF Bandwidth* or *Radio Bandwidth*. The interfering signal offset is defined relative to the *Base Station RF Bandwidth edges* or *Radio Bandwidth edges* applicable to each RIB.

For RIB supporting operation in *non-contiguous spectrum*, the requirement applies in addition inside any *sub-block gap*, in case the *sub-block gap* size is at least 15MHz. The interfering signal offset is defined relative to the *sub-block edges* inside the *sub-block gap* and is equal to -7.5MHz/+7.5MHz, respectively.

For a RIB supporting operation in *non-contiguous spectrum* the narrowband blocking requirement applies in addition inside any *sub-block gap*, in case the *sub-block gap* size is at least 400kHz or 600kHz, depending on the operating band. The interfering signal offset is defined relative to the *sub-block edges* inside the *sub-block gap* and is equal to -200kHz/+200kHz or -300kHz/+300kHz, respectively.

For *multi-band RIBs* the requirement in the in-band blocking frequency range applies for each supported operating band. The requirement applies in addition inside any *Inter RF Bandwidth gap*, in case *Inter RF Bandwidth gap* size is at least 15MHz. The interfering signal offset is defined relative to lower/upper *Base Station RF Bandwidth edges* inside the *Inter RF Bandwidth gap* and is equal to -7.5MHz/+7.5MHz, respectively.

For *multi-band RIBs* the narrowband blocking requirement applies in addition inside any *Inter RF Bandwidth gap*, in case the *Inter RF Bandwidth gap* size is at least 400kHz or 600kHz, depending on the operating band. The interfering signal offset is defined relative to lower/upper *Base Station RF Bandwidth edges* inside the *Inter RF Bandwidth gap* and is equal to -200kHz/+200kHz or -300kHz/+300kHz, respectively.

For the wanted and interfering signal at the RIB, using the parameters in tables 10.6.4.1-1 and 10.6.4.1-2, the following requirements shall be met:

- For any UTRA FDD carrier, the BER shall not exceed 0,001 for the reference measurement channel defined in 3GPP TS 25.104 [6], subclause 7.2.1.

The OTA levels are applied referenced to 2 antenna gain offsets  $\Delta_{OTAREFSENS}$  and  $\Delta_{\min SENS}$ .

**Table 10.6.3.1-1: In-band blocking requirement for Single RAT UTRA AAS BS**

Base Station Type	Mean power of interfering signal [dBm]	Wanted Signal mean power [dBm]	Minimum Offset of Interfering Signal	Type of Interfering Signal
Wide Area BS	$-40 - \Delta_{\text{OTAREFSSENS}}$	$\text{EIS}_{\text{REFSENS}} + 6 \text{ dB}$	$\pm 10 \text{ MHz}$	WCDMA signal (NOTE 1)
	$-40 - \Delta_{\text{minSENS}}$	$\text{EIS}_{\text{minSENS}} + 6 \text{ dB}$		
Medium Range BS	$-35 - \Delta_{\text{OTAREFSSENS}}$	$\text{EIS}_{\text{REFSENS}} + 6 \text{ dB}$		
	$-35 - \Delta_{\text{minSENS}}$	$\text{EIS}_{\text{minSENS}} + 6 \text{ dB}$		
Local Area BS	$-30 - \Delta_{\text{OTAREFSSENS}}$	$\text{EIS}_{\text{REFSENS}} + 6 \text{ dB}$		
	$-30 - \Delta_{\text{minSENS}}$	$\text{EIS}_{\text{minSENS}} + 6 \text{ dB}$		
NOTE 1: The characteristics of the W-CDMA interference signal are specified in Annex C of TS 25.104 [6].				
NOTE 2: For <i>multi-band RIBs</i> , in case of interfering signal that is not in the in-band blocking frequency range of the operating band where the wanted signal is present, and not in the in-band blocking frequency range of an adjacent or overlapping operating band, the wanted Signal mean power is equal to $-119.6 - \Delta_{\text{OTAREFSSENS}}$ dBm or $-119.6 - \Delta_{\text{minSENS}}$ dBm as appropriate.				

NOTE: Table 10.6.4.1 assumes that two operating bands, where the downlink frequencies (see subclause 4.6) of one band would be within the in-band blocking region of the other band, are not deployed in the same geographical area.

**Table 10.6.3.1-2: Blocking performance requirement (narrowband) for Single RAT UTRA AAS BS**

Base Station Type	Mean power of interfering signal [dBm]	Wanted Signal mean power [dBm]	Minimum Offset of Interfering Signal	Type of Interfering Signal
Wide Area BS	$-47 - \Delta_{\text{OTAREFSSENS}}$	$\text{EIS}_{\text{REFSENS}} + 6 \text{ dB}$	$\pm 2.7 \text{ MHz}$ (NOTE 2) $\pm 2.8 \text{ MHz}$ (NOTE 3)	GMSK modulated (NOTE 1)
	$-47 - \Delta_{\text{minSENS}}$	$\text{EIS}_{\text{minSENS}} + 6 \text{ dB}$		
Medium Range BS	$-42 - \Delta_{\text{OTAREFSSENS}}$	$\text{EIS}_{\text{REFSENS}} + 6 \text{ dB}$		
	$-42 - \Delta_{\text{minSENS}}$	$\text{EIS}_{\text{minSENS}} + 6 \text{ dB}$		
Local Area BS	$-37 - \Delta_{\text{OTAREFSSENS}}$	$\text{EIS}_{\text{REFSENS}} + 6 \text{ dB}$		
	$-37 - \Delta_{\text{minSENS}}$	$\text{EIS}_{\text{minSENS}} + 6 \text{ dB}$		
NOTE 1: GMSK modulation as defined in TS 45.004 [26].				
NOTE 2: applies for bands II,IV,V,VIII,X,XII,XIV,XXV,XXVI				
NOTE 3: applies for bands III,VIII				

### 10.6.3.2 Co-location minimum requirement

This additional blocking requirement may be applied for the protection of AAS BS receivers when E-UTRA BS, NR BS, UTRA BS, CDMA BS or GSM/EDGE BS operating in a different frequency band are co-located with an AAS BS.

The requirement is a co-location requirement. The interferer power levels are specified at the *co-location reference antenna* conducted input. The interfering power is specified per supported polarization.

The requirement is valid over *minSENS RoAoA*.

When the wanted and an interfering signal using the parameters in table 10.6.2.2-1 for co-location with UTRA or E-UTRA systems and table 10.6.3.2-1 for co-location with GSM systems, the following requirements shall be met:

- For any UTRA FDD carrier, the BER shall not exceed 0,001 for the reference measurement channel defined in 3GPP TS 25.104 [6], subclause 7.2.1.

**Table 10.6.3.2-1: UTRA additional OTA blocking requirement for co-location with BS in other frequency bands**

Type of co-located BS	Centre Frequency of Interfering Signal [MHz]	Interfering Signal mean power for WA BS [dBm]	Interfering Signal mean power for MR BS [dBm]	Interfering Signal mean power for LA BS [dBm]	Wanted Signal mean power [dBm]	Type of Interfering Signal
GSM850 or CDMA850	869 - 894	+46	+38	+24	$EIS_{\min SENS} + x$ dB (NOTE 1)	CW carrier
GSM900	921 - 960	+46	+38	+24	$EIS_{\min SENS} + x$ dB (NOTE 1)	CW carrier
DCS1800	1805 - 1880 (NOTE 4)	+46	+38	+24	$EIS_{\min SENS} + x$ dB (NOTE 1)	CW carrier
PCS1900	1930 - 1990	+46	+38	+24	$EIS_{\min SENS} + x$ dB (NOTE 1)	CW carrier
UTRA FDD Band I or E-UTRA Band 1 or NR band n1	2110 - 2170	+46	+38	+24	$EIS_{\min SENS} + x$ dB (NOTE 1)	CW carrier
UTRA FDD Band II or E-UTRA Band 2 or NR band n2	1930 - 1990	+46	+38	+24	$EIS_{\min SENS} + x$ dB (NOTE 1)	CW carrier
UTRA FDD Band III or E-UTRA Band 3 or NR band n3	1805 - 1880 (NOTE 4)	+46	+38	+24	$EIS_{\min SENS} + x$ dB (NOTE 1)	CW carrier
UTRA FDD Band IV or E-UTRA Band 4	2110 - 2155	+46	+38	+24	$EIS_{\min SENS} + x$ dB (NOTE 1)	CW carrier
UTRA FDD Band V or E-UTRA Band 5 or NR band n5	869 - 894	+46	+38	+24	$EIS_{\min SENS} + x$ dB (NOTE 1)	CW carrier
UTRA FDD Band VI or E-UTRA Band 6	875 - 885	+46	+38	+24	$EIS_{\min SENS} + x$ dB (NOTE 1)	CW carrier
UTRA FDD Band VII or E-UTRA Band 7 or NR band n7	2620 - 2690	+46	+38	+24	$EIS_{\min SENS} + x$ dB (NOTE 1)	CW carrier
UTRA FDD Band VIII or E-UTRA Band 8 or NR band n8	925 - 960	+46	+38	+24	$EIS_{\min SENS} + x$ dB (NOTE 1)	CW carrier
UTRA FDD Band IX or E-UTRA Band 9	1844.9 - 1879.9	+46	+38	+24	$EIS_{\min SENS} + x$ dB (NOTE 1)	CW carrier
UTRA FDD Band X or E-UTRA Band 10	2110 - 2170	+46	+38	+24	$EIS_{\min SENS} + x$ dB (NOTE 1)	CW carrier
UTRA FDD Band XI or E-UTRA Band 11	1475.9 - 1495.9	+46	+38	+24	$EIS_{\min SENS} + x$ dB (NOTE 1)	CW carrier
UTRA FDD Band XII or E-UTRA Band 12 or NR band n12	729 - 746	+46	+38	+24	$EIS_{\min SENS} + x$ dB (NOTE 1)	CW carrier
UTRA FDD Band XIII or E-UTRA Band 13 or NR band n13	746 - 756	+46	+38	+24	$EIS_{\min SENS} + x$ dB (NOTE 1)	CW carrier
UTRA FDD Band XIV or E-UTRA Band 14 or NR band n14	758 - 768	+46	+38	+24	$EIS_{\min SENS} + x$ dB (NOTE 1)	CW carrier
E-UTRA Band 17	734 - 746	+46	+38	+24	$EIS_{\min SENS} + x$ dB (NOTE 1)	CW carrier
E-UTRA Band 18 or NR Band n18	860 - 875	+46	+38	+24	$EIS_{\min SENS} + x$ dB (NOTE 1)	CW carrier
UTRA FDD Band XIX or E-UTRA Band 19	875 - 890	+46	+38	+24	$EIS_{\min SENS} + x$ dB (NOTE 1)	CW carrier
UTRA FDD Band XX or E-UTRA Band 20 or NR band 20	791 - 821	+46	+38	+24	$EIS_{\min SENS} + x$ dB (NOTE 1)	CW carrier
UTRA FDD Band XXI or E-UTRA Band 21	1495.9 - 1510.9	+46	+38	+24	$EIS_{\min SENS} + x$ dB (NOTE 1)	CW carrier
UTRA FDD Band XXII or E-UTRA Band 22	3510 - 3 590	+46	+38	+24	$EIS_{\min SENS} + x$ dB (NOTE 1)	CW carrier
E-UTRA Band 24 or NR band n24	1525 - 1559	+46	+38	+24	$EIS_{\min SENS} + x$ dB (NOTE 1)	CW carrier

Type of co-located BS	Centre Frequency of Interfering Signal [MHz]	Interfering Signal mean power for WA BS [dBm]	Interfering Signal mean power for MR BS [dBm]	Interfering Signal mean power for LA BS [dBm]	Wanted Signal mean power [dBm]	Type of Interfering Signal
UTRA FDD Band XXV or E-UTRA Band 25 or NR band n25	1930 - 1995	+46	+38	+24	$EIS_{minSENS} + x$ dB (NOTE 1)	CW carrier
UTRA FDD Band XXVI or E-UTRA Band 26 or NR band n26	859 - 894	+46	+38	+24	$EIS_{minSENS} + x$ dB (NOTE 1)	CW carrier
E-UTRA Band 27	852 - 869	+46	+38	+24	$EIS_{minSENS} + x$ dB (NOTE 1)	CW carrier
E-UTRA Band 28 or or NR band n28	758 - 803	+46	+38	+24	$EIS_{minSENS} + x$ dB (NOTE 1)	CW carrier
E-UTRA Band 29 or NR Band n29	717 - 728	+46	+38	+24	$EIS_{minSENS} + x$ dB (NOTE 1)	CW carrier
E-UTRA Band 30 or NR band n30	2350 - 2360	+46	+38	+24	$EIS_{minSENS} + x$ dB (NOTE 1)	CW carrier
E-UTRA Band 31	462.5 - 467.5	+46	+38	+24	$EIS_{minSENS} + x$ dB (NOTE 1)	CW carrier
E-UTRA Band 31	462.5 - 467.5	+46	+38	+24	$EIS_{minSENS} + x$ dB (NOTE 1)	CW carrier
UTRA FDD Band XXXII or E-UTRA Band 32	1452 - 1496 (NOTE-5)	+46	+38	+24	$EIS_{minSENS} + x$ dB (NOTE 1)	CW carrier
UTRA TDD Band a) or E-UTRA TDD Band 33	1900 - 1920	+46	+38	+24	$EIS_{minSENS} + x$ dB (NOTE 1)	CW carrier
UTRA TDD Band a) or E-UTRA TDD Band 34 or NR band n34	2010 - 2025	+46	+38	+24	$EIS_{minSENS} + x$ dB (NOTE 1)	CW carrier
UTRA TDD Band b) or E-UTRA TDD Band 35	1850 - 1910	+46	+38	+24	$EIS_{minSENS} + x$ dB (NOTE 1)	CW carrier
UTRA TDD Band b) or E-UTRA TDD Band 36	1930 - 1990	+46	+38	+24	$EIS_{minSENS} + x$ dB (NOTE 1)	CW carrier
UTRA TDD Band c) or E-UTRA TDD Band 37	1910 - 1930	+46	+38	+24	$EIS_{minSENS} + x$ dB (NOTE 1)	CW carrier
UTRA TDD Band d) or E-UTRA Band 38 or NR band n38	2570 - 2620	+46	+38	+24	$EIS_{minSENS} + x$ dB (NOTE 1)	CW carrier
UTRA TDD Band f) or E-UTRA Band 39 or NR band n39	1880 - 1920	+46	+38	+24	$EIS_{minSENS} + x$ dB (NOTE 1)	CW carrier
UTRA TDD Band e) or E-UTRA Band 40 or NR band n40	2300 - 2400	+46	+38	+24	$EIS_{minSENS} + x$ dB (NOTE 1)	CW carrier
E-UTRA Band 41 or NR band n41	2496 - 2690	+46	+38	+24	$EIS_{minSENS} + x$ dB (NOTE 1)	CW carrier
E-UTRA Band 42	3400 - 3600	+46	+38	+24	$EIS_{minSENS} + x$ dB (NOTE 1)	CW carrier
E-UTRA Band 43	3600 - 3800	+46	+38	+24	$EIS_{minSENS} + x$ dB (NOTE 1)	CW carrier
E-UTRA Band 44	703 - 803	+46	+38	+24	$EIS_{minSENS} + x$ dB (NOTE 1)	CW carrier
E-UTRA Band 45	1447 - 1467	+46	+38	+24	$EIS_{minSENS} + x$ dB (NOTE 1)	CW carrier
E-UTRA Band 46 or NR Band n46	5150 - 5925	N/A	+38	+24	$EIS_{minSENS} + x$ dB (NOTE 1)	CW carrier
E-UTRA Band 48 or NR Band n48	3550 - 3700	+46	+38	+24	$EIS_{minSENS} + x$ dB (NOTE 1)	CW carrier

Type of co-located BS	Centre Frequency of Interfering Signal [MHz]	Interfering Signal mean power for WA BS [dBm]	Interfering Signal mean power for MR BS [dBm]	Interfering Signal mean power for LA BS [dBm]	Wanted Signal mean power [dBm]	Type of Interfering Signal
E-UTRA Band 49	3550 – 3700	N/A	N/A	+24	$EIS_{minSENS} + x$ dB (NOTE 1)	CW carrier
E-UTRA Band 50 or NR band n50	1432 – 1517	+46	+38	+24	$EIS_{minSENS} + x$ dB (NOTE 1)	CW carrier
E-UTRA Band 51 or or NR band n51	1427– 1432	N/A	N/A	+24	$EIS_{minSENS} + x$ dB (NOTE 1)	CW carrier
E-UTRA Band 53 or NR band n53	2483.5 - 2495	N/A	+38	+24	$EIS_{minSENS} + x$ dB (NOTE 1)	CW carrier
E-UTRA Band 65 or NR band n65	2110 – 2200	+46	+38	+24	$EIS_{minSENS} + x$ dB (NOTE 1)	CW carrier
E-UTRA Band 66 or or NR band n66	2110 – 2200	+46	+38	+24	$EIS_{minSENS} + x$ dB (NOTE 1)	CW carrier
E-UTRA Band 67 or NR band n67	738 - 758	+46	+38	+24	$EIS_{minSENS} + x$ dB (NOTE 1)	CW carrier
E-UTRA Band 68	753 - 783	+46	+38	+24	$EIS_{minSENS} + x$ dB (NOTE 1)	CW carrier
E-UTRA Band 69	2570-2620	+46	+38	+24	$EIS_{minSENS} + x$ dB (NOTE 1)	CW carrier
E-UTRA Band 70 or or NR band n70	1995 - 2020	+46	+38	+24	$EIS_{minSENS} + x$ dB (NOTE 1)	CW carrier
E-UTRA Band 71 or or NR band n71	617 - 652	+46	+38	+24	$EIS_{minSENS} + x$ dB (NOTE 1)	CW carrier
E-UTRA Band 72	461 - 466	+46	+38	+24	$EIS_{minSENS} + x$ dB (NOTE 1)	CW carrier
E-UTRA Band 73	460 - 465	+46	+38	+24	$EIS_{minSENS} + x$ dB (NOTE 1)	CW carrier
E-UTRA Band 74 or NR band n74	1475 - 1518	+46	+38	+24	$EIS_{minSENS} + x$ dB (NOTE 1)	CW carrier
E-UTRA Band 75 or or NR band n75	1432 - 1517	+46	+38	+24	$EIS_{minSENS} + x$ dB (NOTE 1)	CW carrier
E-UTRA Band 76 or or NR band n76	1427 - 1432	N/A	N/A	+24	$EIS_{minSENS} + x$ dB (NOTE 1)	CW carrier
NR band n77	3300 - 4200	+46	+38	+24	$EIS_{minSENS} + x$ dB (NOTE 1)	CW carrier
NR band n78	3300 - 3800	+46	+38	+24	$EIS_{minSENS} + x$ dB (NOTE 1)	CW carrier
NR band n79	4400 - 5000	+46	+38	+24	$EIS_{minSENS} + x$ dB (NOTE 1)	CW carrier
E-UTRA Band 85 or NR band n85	728 – 746	+46	+38	+24	$EIS_{minSENS} + x$ dB (NOTE 1)	CW carrier
E-UTRA Band 87	420 - 425	+46	+38	+24	$EIS_{minSENS} + x$ dB (NOTE 1)	CW carrier
E-UTRA Band 88	422 - 427	+46	+38	+24	$EIS_{minSENS} + x$ dB (NOTE 1)	CW carrier
NR band n91	1427 - 1432	N/A	N/A	+24	$EIS_{minSENS} + x$ dB (NOTE 1)	CW carrier
NR band n92	1432 - 1517	+46	+38	+24	$EIS_{minSENS} + x$ dB (NOTE 1)	CW carrier
NR band n93	1427 - 1432	N/A	N/A	+24	$EIS_{minSENS} + x$ dB (NOTE 1)	CW carrier
NR band n94	1432 - 1517	+46	+38	+24	$EIS_{minSENS} + x$ dB (NOTE 1)	CW carrier
NR band n96	5925 - 7125	N/A	+38	+24	$EIS_{minSENS} + x$ dB (NOTE 1)	CW carrier
NR band n102	5925 - 6425	N/A	+38	+24	$EIS_{minSENS} + x$ dB (NOTE 1)	CW carrier
E-UTRA Band 103	757 - 758	+46	+38	+24	$EIS_{minSENS} + x$ dB (NOTE 1)	CW carrier

Type of co-located BS	Centre Frequency of Interfering Signal [MHz]	Interfering Signal mean power for WA BS [dBm]	Interfering Signal mean power for MR BS [dBm]	Interfering Signal mean power for LA BS [dBm]	Wanted Signal mean power [dBm]	Type of Interfering Signal
NOTE 1: $EIS_{\min SENS}$ depends on the BS class and on the <i>channel bandwidth</i> , see subclause 10.2.						
NOTE 2: Except for a BS operating in Band 13, these requirements do not apply when the interfering signal falls within any of the supported <i>uplink operating band</i> or in the $\Delta f_{OOB}$ immediately outside any of the supported <i>uplink operating band</i> . For a BS operating in band 13 the requirements do not apply when the interfering signal falls within the frequency range 768 - 797 MHz.						
NOTE 3: Some combinations of bands may not be possible to co-site based on the requirements above. The current state-of-the-art technology does not allow a single generic solution for co-location of UTRA TDD or E-UTRA TDD or NR TDD with E-UTRA FDD or NR FDD on adjacent frequencies with closely spaced antennas. However, there are certain site-engineering solutions that can be used. These techniques are addressed in 3GPP TR 25.942 [12].						
NOTE 4: In China, the blocking requirement for co-location with DCS1800 and Band III BS is only applicable in the frequency range 1805 - 1850 MHz.						
NOTE 5: For an AAS BS operating in band 11, 21, or 74 this requirement applies for interfering signal within the frequency range 1475.9 - 1495.9 MHz.						

## 10.6.4 Minimum requirement for single RAT E-UTRA operation

### 10.6.4.1 General minimum requirement

In addition to the following in-band and narrowband requirements, the general minimum requirements relating to out of band blocking defined for MSR in subclause 10.6.2.1 shall also be applied for single RAT E-UTRA operation.

The minimum requirement for in-band blocking E-UTRA operation is defined below:

The requirement is applicable outside the *Base Station RF Bandwidth* or *Radio Bandwidth*. The interfering signal offset is defined relative to the *Base Station RF Bandwidth edges* or *Radio Bandwidth edges* applicable to each RIB.

For RIB supporting operation in *non-contiguous spectrum*, the requirement applies in addition inside any *sub-block gap*, in case the *sub-block gap* size is at least 15 MHz. The interfering signal offset is defined relative to the *sub-block edges* inside the *sub-block gap*.

For *multi-band RIBs*, the requirement applies in addition inside any *Inter RF Bandwidth gap*, in case the gap size is at least 15 MHz. The interfering signal offset is defined relative to the *Base Station RF Bandwidth edges* inside the *Inter RF Bandwidth gap*.

For the wanted and interfering signal at the RIB, using the parameters in tables 10.6.4.1-1 and 10.6.4.1-2, the following requirements shall be met:

- For any E-UTRA carrier, the throughput shall be  $\geq 95\%$  of the *maximum throughput* of the reference measurement channel defined in 3GPP TS 36.104 [8], subclause 7.2.1.

The OTA levels are applied referenced to 2 antenna gain offsets  $\Delta_{OTAREFSENS}$  and  $\Delta_{\min SENS}$ .

For *multi-band RIBs*, the requirement applies according to table 10.6.4.1-1 for the in-band blocking frequency ranges of each supported operating band.

Table 10.6.4.1-1: In-band blocking requirement for single RAT E-UTRA

Base Station Type	Mean power of interfering signal [dBm]	Wanted Signal mean power [dBm] (NOTE 1,2)	Type of Interfering Signal	Interfering signal centre frequency minimum offset from the <i>Base Station RF Bandwidth edge or edge of sub-block inside a gap</i> [MHz]
Wide Area BS	$-43 - \Delta_{OTAREFSENS}$	$EIS_{REFSENS} + 6$ dB	See table 10.6.4.1-2	See table 10.6.4.1-2
	$-43 - \Delta_{minSENS}$	$EIS_{minSENS} + 6$ dB		
Medium Range BS	$-38 - \Delta_{OTAREFSENS}$	$EIS_{REFSENS} + 6$ dB		
	$-38 - \Delta_{minSENS}$	$EIS_{minSENS} + 6$ dB		
Local Area BS	$-35 - \Delta_{OTAREFSENS}$	$EIS_{REFSENS} + 6$ dB		
	$-35 - \Delta_{minSENS}$	$EIS_{minSENS} + 6$ dB		
NOTE 1: $EIS_{REFSENS}$ and $EIS_{minSENS}$ depend on the RAT, the BS class and on the <i>channel bandwidth</i> , see subclauses 10.3 and 10.2.				
NOTE 2: For <i>multi-band RIBs</i> , in case of interfering signal that is not in the in-band blocking frequency range of the operating band where the wanted signal is present, and not in the in-band blocking frequency range of an adjacent or overlapping operating band, the wanted signal mean power is equal to $EIS_{REFSENS} + 1.4$ dB or $EIS_{minSENS} + 1.4$ dB as appropriate.				

Table 10.6.4.1-2: Interfering signals for single RAT E-UTRA in-band blocking performance requirement

E-UTRA channel BW of the lowest/highest carrier received [MHz]	Interfering signal centre frequency minimum offset to the lower/upper <i>Base Station RF Bandwidth edge or sub-block edge inside a sub-block gap</i> [MHz]	Type of interfering signal
1.4	$\pm 2.1$	1.4 MHz E-UTRA signal
3	$\pm 4.5$	3 MHz E-UTRA signal
5	$\pm 7.5$	5 MHz E-UTRA signal
10	$\pm 7.5$	5 MHz E-UTRA signal
15	$\pm 7.5$	5 MHz E-UTRA signal
20	$\pm 7.5$	5 MHz E-UTRA signal
20	$\pm 30$	20 MHz E-UTRA signal

### 10.6.4.2 Co-location minimum requirement

This additional blocking requirement may be applied for the protection of *AAS BS receivers* when E-UTRA BS, NR BS, UTRA BS, CDMA BS or GSM/EDGE BS operating in a different frequency band are co-located with an AAS BS.

The requirement is a co-location requirement. The interferer power levels are specified at the *co-location reference antenna* conducted input. The interfering power is specified per supported polarization.

The requirement is valid over *minSENS RoAoA*.

When the wanted and an interfering signal using the parameters in table 10.6.2.2-1 for co-location with UTRA or E-UTRA systems and table 10.6.4.2-1 for co-location with GSM systems, the following requirements shall be met:

- For any E-UTRA carrier, the throughput shall be  $\geq 95$  % of the *maximum throughput* of the reference measurement channel defined in 3GPP TS 36.104 [8], subclause 7.2.1.

**Table 10.6.4.2-1: E-UTRA additional OTA blocking requirement for co-location with BS in other frequency bands**

Type of co-located BS	Centre Frequency of Interfering Signal [MHz]	Interfering Signal mean power for WA BS [dBm]	Interfering Signal mean power for MR BS [dBm]	Interfering Signal mean power for LA BS [dBm]	Wanted Signal mean power [dBm]	Type of Interfering Signal
GSM850 or CDMA850	869 - 894	+46	+38	+24	$EIS_{\min SENS} + x$ dB (NOTE 1)	CW carrier
GSM900	921 - 960	+46	+38	+24	$EIS_{\min SENS} + x$ dB (NOTE 1)	CW carrier
DCS1800	1805 - 1880 (NOTE 4)	+46	+38	+24	$EIS_{\min SENS} + x$ dB (NOTE 1)	CW carrier
PCS1900	1930 - 1990	+46	+38	+24	$EIS_{\min SENS} + x$ dB (NOTE 1)	CW carrier
UTRA FDD Band I or E-UTRA Band 1 or NR band n1	2110 - 2170	+46	+38	+24	$EIS_{\min SENS} + x$ dB (NOTE 1)	CW carrier
UTRA FDD Band II or E-UTRA Band 2 or NR band n2	1930 - 1990	+46	+38	+24	$EIS_{\min SENS} + x$ dB (NOTE 1)	CW carrier
UTRA FDD Band III or E-UTRA Band 3 or NR band n3	1805 - 1880 (NOTE 4)	+46	+38	+24	$EIS_{\min SENS} + x$ dB (NOTE 1)	CW carrier
UTRA FDD Band IV or E-UTRA Band 4	2110 - 2155	+46	+38	+24	$EIS_{\min SENS} + x$ dB (NOTE 1)	CW carrier
UTRA FDD Band V or E-UTRA Band 5 or NR band n5	869 - 894	+46	+38	+24	$EIS_{\min SENS} + x$ dB (NOTE 1)	CW carrier
UTRA FDD Band VI or E-UTRA Band 6	875 - 885	+46	+38	+24	$EIS_{\min SENS} + x$ dB (NOTE 1)	CW carrier
UTRA FDD Band VII or E-UTRA Band 7 or NR band n7	2620 - 2690	+46	+38	+24	$EIS_{\min SENS} + x$ dB (NOTE 1)	CW carrier
UTRA FDD Band VIII or E-UTRA Band 8 or NR band n8	925 - 960	+46	+38	+24	$EIS_{\min SENS} + x$ dB (NOTE 1)	CW carrier
UTRA FDD Band IX or E-UTRA Band 9	1844.9 - 1879.9	+46	+38	+24	$EIS_{\min SENS} + x$ dB (NOTE 1)	CW carrier
UTRA FDD Band X or E-UTRA Band 10	2110 - 2170	+46	+38	+24	$EIS_{\min SENS} + x$ dB (NOTE 1)	CW carrier
UTRA FDD Band XI or E-UTRA Band 11	1475.9 - 1495.9	+46	+38	+24	$EIS_{\min SENS} + x$ dB (NOTE 1)	CW carrier
UTRA FDD Band XII or E-UTRA Band 12 or NR band n12	729 - 746	+46	+38	+24	$EIS_{\min SENS} + x$ dB (NOTE 1)	CW carrier
UTRA FDD Band XIII or E-UTRA Band 13 or NR band n13	746 - 756	+46	+38	+24	$EIS_{\min SENS} + x$ dB (NOTE 1)	CW carrier
UTRA FDD Band XIV or E-UTRA Band 14 or NR band n14	758 - 768	+46	+38	+24	$EIS_{\min SENS} + x$ dB (NOTE 1)	CW carrier
E-UTRA Band 17	734 - 746	+46	+38	+24	$EIS_{\min SENS} + x$ dB (NOTE 1)	CW carrier
E-UTRA Band 18 or NR Band n18	860 - 875	+46	+38	+24	$EIS_{\min SENS} + x$ dB (NOTE 1)	CW carrier
UTRA FDD Band XIX or E-UTRA Band 19	875 - 890	+46	+38	+24	$EIS_{\min SENS} + x$ dB (NOTE 1)	CW carrier
UTRA FDD Band XX or E-UTRA Band 20 or NR band 20	791 - 821	+46	+38	+24	$EIS_{\min SENS} + x$ dB (NOTE 1)	CW carrier
UTRA FDD Band XXI or E-UTRA Band 21	1495.9 - 1510.9	+46	+38	+24	$EIS_{\min SENS} + x$ dB (NOTE 1)	CW carrier
UTRA FDD Band XXII or E-UTRA Band 22	3510 - 3 590	+46	+38	+24	$EIS_{\min SENS} + x$ dB (NOTE 1)	CW carrier
E-UTRA Band 24 or NR band n24	1525 - 1559	+46	+38	+24	$EIS_{\min SENS} + x$ dB (NOTE 1)	CW carrier

Type of co-located BS	Centre Frequency of Interfering Signal [MHz]	Interfering Signal mean power for WA BS [dBm]	Interfering Signal mean power for MR BS [dBm]	Interfering Signal mean power for LA BS [dBm]	Wanted Signal mean power [dBm]	Type of Interfering Signal
UTRA FDD Band XXV or E-UTRA Band 25 or NR band n25	1930 - 1995	+46	+38	+24	$EIS_{minSENS} + x$ dB (NOTE 1)	CW carrier
UTRA FDD Band XXVI or E-UTRA Band 26 or NR band n26	859 - 894	+46	+38	+24	$EIS_{minSENS} + x$ dB (NOTE 1)	CW carrier
E-UTRA Band 27	852 – 869	+46	+38	+24	$EIS_{minSENS} + x$ dB (NOTE 1)	CW carrier
E-UTRA Band 28 or or NR band n28	758 – 803	+46	+38	+24	$EIS_{minSENS} + x$ dB (NOTE 1)	CW carrier
E-UTRA Band 29 or NR Band n29	717 - 728	+46	+38	+24	$EIS_{minSENS} + x$ dB (NOTE 1)	CW carrier
E-UTRA Band 30 or NR band n30	2350 - 2360	+46	+38	+24	$EIS_{minSENS} + x$ dB (NOTE 1)	CW carrier
E-UTRA Band 31	462.5 - 467.5	+46	+38	+24	$EIS_{minSENS} + x$ dB (NOTE 1)	CW carrier
E-UTRA Band 31	462.5 - 467.5	+46	+38	+24	$EIS_{minSENS} + x$ dB (NOTE 1)	CW carrier
UTRA FDD Band XXXII or E-UTRA Band 32	1452 - 1496 (NOTE-5)	+46	+38	+24	$EIS_{minSENS} + x$ dB (NOTE 1)	CW carrier
UTRA TDD Band a) or E-UTRA TDD Band 33	1900 - 1920	+46	+38	+24	$EIS_{minSENS} + x$ dB (NOTE 1)	CW carrier
UTRA TDD Band a) or E-UTRA TDD Band 34 or NR band n34	2010 - 2025	+46	+38	+24	$EIS_{minSENS} + x$ dB (NOTE 1)	CW carrier
UTRA TDD Band b) or E-UTRA TDD Band 35	1850 - 1910	+46	+38	+24	$EIS_{minSENS} + x$ dB (NOTE 1)	CW carrier
UTRA TDD Band b) or E-UTRA TDD Band 36	1930 - 1990	+46	+38	+24	$EIS_{minSENS} + x$ dB (NOTE 1)	CW carrier
UTRA TDD Band c) or E-UTRA TDD Band 37	1910 - 1930	+46	+38	+24	$EIS_{minSENS} + x$ dB (NOTE 1)	CW carrier
UTRA TDD Band d) or E-UTRA Band 38 or NR band n38	2570 - 2620	+46	+38	+24	$EIS_{minSENS} + x$ dB (NOTE 1)	CW carrier
UTRA TDD Band f) or E-UTRA Band 39 or NR band n39	1880 - 1920	+46	+38	+24	$EIS_{minSENS} + x$ dB (NOTE 1)	CW carrier
UTRA TDD Band e) or E-UTRA Band 40 or NR band n40	2300 - 2400	+46	+38	+24	$EIS_{minSENS} + x$ dB (NOTE 1)	CW carrier
E-UTRA Band 41 or NR band n41	2496 - 2690	+46	+38	+24	$EIS_{minSENS} + x$ dB (NOTE 1)	CW carrier
E-UTRA Band 42	3400 - 3600	+46	+38	+24	$EIS_{minSENS} + x$ dB (NOTE 1)	CW carrier
E-UTRA Band 43	3600 - 3800	+46	+38	+24	$EIS_{minSENS} + x$ dB (NOTE 1)	CW carrier
E-UTRA Band 44	703 - 803	+46	+38	+24	$EIS_{minSENS} + x$ dB (NOTE 1)	CW carrier
E-UTRA Band 45	1447 - 1467	+46	+38	+24	$EIS_{minSENS} + x$ dB (NOTE 1)	CW carrier
E-UTRA Band 46 or NR Band n46	5150 - 5925	N/A	+38	+24	$EIS_{minSENS} + x$ dB (NOTE 1)	CW carrier
E-UTRA Band 48 or NR Band n48	3550 – 3700	+46	+38	+24	$EIS_{minSENS} + x$ dB (NOTE 1)	CW carrier

Type of co-located BS	Centre Frequency of Interfering Signal [MHz]	Interfering Signal mean power for WA BS [dBm]	Interfering Signal mean power for MR BS [dBm]	Interfering Signal mean power for LA BS [dBm]	Wanted Signal mean power [dBm]	Type of Interfering Signal
E-UTRA Band 49	3550 – 3700	N/A	N/A	+24	$EIS_{minSENS} + x$ dB (NOTE 1)	CW carrier
E-UTRA Band 50 or NR band n50	1432 – 1517	+46	+38	+24	$EIS_{minSENS} + x$ dB (NOTE 1)	CW carrier
E-UTRA Band 51 or or NR band n51	1427– 1432	N/A	N/A	+24	$EIS_{minSENS} + x$ dB (NOTE 1)	CW carrier
E-UTRA Band 53 or NR band n53	2483.5 - 2495	N/A	+38	+24	$EIS_{minSENS} + x$ dB (NOTE 1)	CW carrier
E-UTRA Band 65 or NR band n65	2110 – 2200	+46	+38	+24	$EIS_{minSENS} + x$ dB (NOTE 1)	CW carrier
E-UTRA Band 66 or or NR band n66	2110 – 2200	+46	+38	+24	$EIS_{minSENS} + x$ dB (NOTE 1)	CW carrier
E-UTRA Band 67 or NR band n67	738 - 758	+46	+38	+24	$EIS_{minSENS} + x$ dB (NOTE 1)	CW carrier
E-UTRA Band 68	753 - 783	+46	+38	+24	$EIS_{minSENS} + x$ dB (NOTE 1)	CW carrier
E-UTRA Band 69	2570-2620	+46	+38	+24	$EIS_{minSENS} + x$ dB (NOTE 1)	CW carrier
E-UTRA Band 70 or or NR band n70	1995 - 2020	+46	+38	+24	$EIS_{minSENS} + x$ dB (NOTE 1)	CW carrier
E-UTRA Band 71 or or NR band n71	617 - 652	+46	+38	+24	$EIS_{minSENS} + x$ dB (NOTE 1)	CW carrier
E-UTRA Band 72	461 - 466	+46	+38	+24	$EIS_{minSENS} + x$ dB (NOTE 1)	CW carrier
E-UTRA Band 73	460 - 465	+46	+38	+24	$EIS_{minSENS} + x$ dB (NOTE 1)	CW carrier
E-UTRA Band 74 or NR band n74	1475 - 1518	+46	+38	+24	$EIS_{minSENS} + x$ dB (NOTE 1)	CW carrier
E-UTRA Band 75 or or NR band n75	1432 - 1517	+46	+38	+24	$EIS_{minSENS} + x$ dB (NOTE 1)	CW carrier
E-UTRA Band 76 or or NR band n76	1427 - 1432	N/A	N/A	+24	$EIS_{minSENS} + x$ dB (NOTE 1)	CW carrier
NR band n77	3300 - 4200	+46	+38	+24	$EIS_{minSENS} + x$ dB (NOTE 1)	CW carrier
NR band n78	3300 - 3800	+46	+38	+24	$EIS_{minSENS} + x$ dB (NOTE 1)	CW carrier
NR band n79	4400 - 5000	+46	+38	+24	$EIS_{minSENS} + x$ dB (NOTE 1)	CW carrier
E-UTRA Band 85 or NR band n85	728 – 746	+46	+38	+24	$EIS_{minSENS} + x$ dB (NOTE 1)	CW carrier
E-UTRA Band 87	420 - 425	+46	+38	+24	$EIS_{minSENS} + x$ dB (NOTE 1)	CW carrier
E-UTRA Band 88	422 - 427	+46	+38	+24	$EIS_{minSENS} + x$ dB (NOTE 1)	CW carrier
NR band n91	1427 - 1432	N/A	N/A	+24	$EIS_{minSENS} + x$ dB (NOTE 1)	CW carrier
NR band n92	1432 - 1517	+46	+38	+24	$EIS_{minSENS} + x$ dB (NOTE 1)	CW carrier
NR band n93	1427 - 1432	N/A	N/A	+24	$EIS_{minSENS} + x$ dB (NOTE 1)	CW carrier
NR band n94	1432 - 1517	+46	+38	+24	$EIS_{minSENS} + x$ dB (NOTE 1)	CW carrier
NR band n96	5925 - 7125	N/A	+38	+24	$EIS_{minSENS} + x$ dB (NOTE 1)	CW carrier
NR band n102	5925 - 6425	N/A	+38	+24	$EIS_{minSENS} + x$ dB (NOTE 1)	CW carrier
E-UTRA Band 103	757 - 758	+46	+38	+24	$EIS_{minSENS} + x$ dB (NOTE 1)	CW carrier

Type of co-located BS	Centre Frequency of Interfering Signal [MHz]	Interfering Signal mean power for WA BS [dBm]	Interfering Signal mean power for MR BS [dBm]	Interfering Signal mean power for LA BS [dBm]	Wanted Signal mean power [dBm]	Type of Interfering Signal
NOTE 1: $EIS_{\min SENS}$ depends on the BS class and on the <i>channel bandwidth</i> , see subclause 10.2.						
NOTE 2: Except for a BS operating in Band 13, these requirements do not apply when the interfering signal falls within any of the supported <i>uplink operating band</i> or in the $\Delta f_{OOB}$ immediately outside any of the supported <i>uplink operating band</i> . For a BS operating in band 13 the requirements do not apply when the interfering signal falls within the frequency range 768 - 797 MHz.						
NOTE 3: Some combinations of bands may not be possible to co-site based on the requirements above. The current state-of-the-art technology does not allow a single generic solution for co-location of UTRA TDD or E-UTRA TDD or NR TDD with E-UTRA FDD or NR FDD on adjacent frequencies with closely spaced antennas. However, there are certain site-engineering solutions that can be used. These techniques are addressed in 3GPP TR 25.942 [12].						
NOTE 4: In China, the blocking requirement for co-location with DCS1800 and Band III BS is only applicable in the frequency range 1805 - 1850 MHz.						
NOTE 5: For an AAS BS operating in band 11, 21, or 74 the requirement for co-location with Band 32 applies for interfering signal within the frequency range 1475.9 - 1495.9 MHz.						

## 10.7 OTA Receiver spurious emissions

### 10.7.1 General

The receiver spurious emission requirement is the power of the emissions radiated from the antenna array from a receiver unit. For an *OTA AAS BS* operating in FDD, OTA RX spurious emissions requirement do not apply as they are superseded by the OTA TX spurious emissions requirement. This is due to the fact that TX and RX spurious emissions cannot be distinguished in OTA domain.

NOTE: The OTA receiver spurious emission requirement applicability for the AAS BS with the RX-only capabilities is not covered by the present release of this specification.

For an *OTA AAS BS* operating in TDD, the OTA receiver spurious emissions requirement applies during the *transmitter OFF period* only.

For RX only *multi-band RIB*, the RX spurious emissions requirements are subject to exclusion zones in each supported operating band.

### 10.7.2 Minimum requirement for MSR operation

#### 10.7.2.1 General minimum requirement

There are no OTA receiver spurious emissions requirements for UTRA FDD.

For E-UTRA, the minimum requirement is specified in subclause 10.7.4

For NR, the minimum requirement is the same as that specified for *BS type I-O* in TS 38.104 [28] in subclause 10.7.2

#### 10.7.3 Minimum requirement for single RAT UTRA operation

There are no OTA receiver spurious emissions requirements for single RAT UTRA FDD.

#### 10.7.4 Minimum requirement for single RAT E-UTRA operation

The TRP of any spurious emission shall not exceed the limits in table 10.7.4-1:

Table 10.7.4-1: General spurious emission minimum requirement

Frequency range	Maximum level (Note 2, Note 3)	Measurement bandwidth	NOTE
30MHz - 1 GHz	-36 + X dBm	100 kHz	Note 4
1 GHz - 12.75 GHz	-30 + X dBm	1 MHz	Note 4, Note 5
12.75 GHz - 5 <sup>th</sup> harmonic of the upper frequency edge of the UL operating band in GHz	-30 + X dBm	1 MHz	Note 5, Note 5, Note 6
NOTE 1: The frequency range from $\Delta f_{\text{OBUE}}$ below the lowest frequency of the BS transmitter <i>operating band</i> to $\Delta f_{\text{OBUE}}$ above the highest frequency of the BS transmitter <i>operating band</i> may be excluded from the requirement. $\Delta f_{\text{OBUE}}$ is defined in clause 6.6.1. For a <i>multiband RIB</i> , the exclusion applies for all supported operating bands. NOTE 2: X = 9 dB, unless stated differently in regional regulation. NOTE 3: Additional limits may apply regionally. NOTE 4: Measurement bandwidths as in ITU-R SM.329 [x], s4.1. NOTE 5: Upper frequency as in ITU-R SM.329 [x], s2.5 table 1. NOTE 6: This spurious frequency range applies only for <i>operating bands</i> for which the 5 <sup>th</sup> harmonic of the upper frequency edge of the UL <i>operating band</i> is reaching beyond 12.75 GHz.			

In addition to the requirements in table 10.7.4-1, the power of any spurious emission shall not exceed the levels specified for Protection of the E-UTRA FDD BS receiver of own or different BS in subclause 9.7.6.4.2 and for Co-existence with other systems in the same geographical area in subclause 9.7.6.4.3. In addition, the co-existence requirements for co-located base stations specified in subclause 9.7.6.4.4 may also be applied.

## 10.8 OTA Receiver intermodulation

### 10.8.1 General

Third and higher order mixing of the two interfering RF signals can produce an interfering signal in the band of the desired channel. Intermodulation response rejection is a measure of the capability of the receiver unit to receive a wanted signal on its assigned channel frequency in the presence of two interfering signals which have a specific frequency relationship to the wanted signal.

The requirement applies at the RIB when the AoA of the incident wave of a received signal and the interfering signal are from the same direction, and:

- when the wanted signal is based on  $EIS_{\text{REFSENS}}$ : the AoA of the incident wave of a received signal and the interfering signal are within the OTA  $REFSENS$   $RoAoA$ .
- when the wanted signal is based on  $EIS_{\text{minSENS}}$ : the AoA of the incident wave of a received signal and the interfering signal are within the  $minSENS$   $RoAoA$ .

The wanted and interfering signals apply to each supported polarization, under the assumption of *polarization match*.

### 10.8.2 Minimum requirement for MSR operation

#### 10.8.2.1 General intermodulation minimum requirement

Interfering signals shall be a CW signal and an E-UTRA or UTRA signal as specified in 3GPP TS 37.104 [9], annex A.

The requirement is applicable outside the *Base Station RF Bandwidth* or *Radio Bandwidth*. The interfering signal offset is defined relative to the *Base Station RF Bandwidth edges* or *Radio Bandwidth edges*.

For *multi-band RIBs*, the requirement applies in addition inside any *Inter RF Bandwidth gap*, in case the gap size is at least twice as wide as the UTRA/E-UTRA interfering signal centre frequency offset from the *Base Station RF Bandwidth edge*. The interfering signal offset is defined relative to the *Base Station RF Bandwidth edges* inside the *Inter RF Bandwidth gap*.

For the wanted signal at the assigned channel frequency and two interfering signals at the RIB, using the parameters in tables 10.8.2.1-1 and 10.8.2.1-2, the following requirements shall be met:

- For any E-UTRA carrier, the throughput shall be  $\geq 95\%$  of the *maximum throughput* of the reference measurement channel defined in 3GPP TS 36.104 [8], subclause 7.2.1.
- For any UTRA FDD carrier, the BER shall not exceed 0,001 for the reference measurement channel defined in 3GPP TS 25.104 [6], subclause 7.2.1.
- For any NR carrier, the throughput shall be  $\geq 95\%$  of the maximum throughput of the reference measurement channel defined for *BS type 1-O* in TS 38.104 [28], subclause 10.3.2

The OTA levels are applied referenced to 2 antenna gain offsets  $\Delta_{OTAREFSENS}$  and  $\Delta_{minSENS}$ .

**Table 10.8.2.1-1: General intermodulation requirement**

Base Station Type	Mean power of interfering signals [dBm]	Wanted Signal mean power [dBm] (NOTE 1)	Type of interfering signals
Wide Area BS	$-48 + y - \Delta_{OTAREFSENS}$ (NOTE 6)	$EIS_{REFSENS} + x$ dB (NOTE 2, 5)	See table 10.8.2.1-2
	$-48 + y - \Delta_{minSENS}$ (NOTE 6)	$EIS_{minSENS} + x$ dB (NOTE 2, 5)	
Medium Range BS	$-44 + y - \Delta_{OTAREFSENS}$ (NOTE 6)	$EIS_{REFSENS} + x$ dB (NOTE 3, 5)	
	$-44 + y - \Delta_{minSENS}$ (NOTE 6)	$EIS_{minSENS} + x$ dB (NOTE 3, 5)	
Local Area BS	$-38 + y - \Delta_{OTAREFSENS}$ (NOTE 6)	$EIS_{REFSENS} + x$ dB (NOTE 4, 5)	
	$-38 + y - \Delta_{minSENS}$ (NOTE 6)	$EIS_{minSENS} + x$ dB (NOTE 4, 5)	
<p>NOTE 1: <math>EIS_{REFSENS}</math> and <math>EIS_{minSENS}</math> depend on the RAT, the BS class and on the <i>channel bandwidth</i>, see subclauses 10.3 and 10.2.</p> <p>NOTE 2: For WA BS supporting UTRA, "x" is equal to 6 in case of NR or E-UTRA or UTRA wanted signals.</p> <p>NOTE 3: For MR BS supporting UTRA, "x" is equal to 6 in case of UTRA wanted signals, 9 in case of NR or E-UTRA wanted signal.</p> <p>NOTE 4: For LA BS supporting UTRA, "x" is equal to 12 in case of E-UTRA wanted signals, 6 in case of NR or UTRA wanted signal.</p> <p>NOTE 5: For a BS and not supporting UTRA, x is equal to 6 for all BS classes if NR is supported, otherwise x is equal to 6 for WA BS or 9 for MR or 12 for LA BS if NR is not supported.</p> <p>NOTE 6: For a BS that supports NR but not UTRA; "y" is equal to -4 for the WA BS class, -3 for the MR BS class and -6 for the LA BS class. For all other cases, "y" is equal to zero for all BS classes.</p>			

Table 10.8.2.1-2: Interfering signals for intermodulation requirement

RAT of the carrier adjacent to the upper/lower Base Station RF Bandwidth edge	Interfering signal centre frequency offset from the Base Station RF Bandwidth edge [MHz]	Type of interfering signal
E-UTRA 1.4 MHz	$\pm 2,0$ (BC1 and BC3) / $\pm 2,1$ (BC2)	CW
	$\pm 4,9$	1,4 MHz E-UTRA signal
E-UTRA 3 MHz	$\pm 4,4$ (BC1 and BC3) / $\pm 4,5$ (BC2)	CW
	$\pm 10,5$	3 MHz E-UTRA signal
UTRA FDD and E-UTRA 5 MHz	$\pm 7,5$	CW
	$\pm 17,5$	5 MHz E-UTRA signal
E-UTRA 10 MHz	$\pm 7,375$	CW
	$\pm 17,5$	5 MHz E-UTRA signal
E-UTRA 15 MHz	$\pm 7,25$	CW
	$\pm 17,5$	5 MHz E-UTRA signal
E-UTRA 20 MHz	$\pm 7,125$	CW
	$\pm 17,5$	5 MHz E-UTRA signal
GSM/EDGE	$\pm 7,575$	CW
	$\pm 17,5$	5 MHz E-UTRA signal
1,28 Mcps UTRA TDD	$\pm 2,3$ (BC3)	CW
	$\pm 5,6$ (BC3)	1,28 Mcps UTRA TDD signal
NR 5 MHz	$\pm 7,5$	CW
	$\pm 17,5$	5MHz E-UTRA signal
NR 10 MHz	$\pm 7,45$	CW
	$\pm 17,5$	5MHz E-UTRA signal
NR 15 MHz	$\pm 7,43$	CW
	$\pm 17,5$	5MHz E-UTRA signal
NR 20 MHz	$\pm 7,38$	CW
	$\pm 17,5$	5MHz E-UTRA signal
NR 25 MHz	$\pm 7,45$	CW
	$\pm 25$	20MHz E-UTRA signal
NR 30 MHz	$\pm 7,43$	CW
	$\pm 25$	20MHz E-UTRA signal
NR 35 MHz	$\pm 7,44$	CW
	$\pm 25$	20MHz E-UTRA signal
NR 40 MHz	$\pm 7,45$	CW
	$\pm 25$	20MHz E-UTRA signal
NR 45 MHz	$\pm 7,37$	CW
	$\pm 25$	20MHz E-UTRA signal
NR 50 MHz	$\pm 7,35$	CW
	$\pm 25$	20MHz E-UTRA signal
NR 60 MHz	$\pm 7,49$	CW
	$\pm 25$	20MHz E-UTRA signal
NR 70 MHz	$\pm 7,42$	CW
	$\pm 25$	20MHz E-UTRA signal
NR 80 MHz	$\pm 7,44$	CW
	$\pm 25$	20MHz E-UTRA signal
NR 90 MHz	$\pm 25$	CW
	$\pm 7,43$	20MHz E-UTRA signal
NR 100 MHz	$\pm 7,45$	CW
	$\pm 25$	20MHz E-UTRA signal

### 10.8.2.2 General narrowband intermodulation minimum requirement

Interfering signals shall be a CW signal and an E-UTRA 1RB signal as specified in 3GPP TS 37.104 [9], annex A.

The requirement is applicable outside the *Base Station RF Bandwidth* or *Radio Bandwidth*. The interfering signal offset is defined relative to the *Base Station RF Bandwidth edges* or *Radio Bandwidth edges*.

For RIB supporting operation in *non-contiguous spectrum* within each supported operating band, the requirement applies in addition inside any *sub-block gap* in case the *sub-block gap* is at least as wide as the *channel bandwidth* of the E-UTRA interfering signal in table 10.8.2.2-2. The interfering signal offset is defined relative to the *sub-block* edges inside the gap.

For *multi-band RIBs*, the requirement applies in addition inside any *Inter RF Bandwidth gap*, in case the gap size is at least as wide as the E-UTRA interfering signal in table 10.8.2.2-2. The interfering signal offset is defined relative to the *Base Station RF Bandwidth edges* inside the *Inter RF Bandwidth gap*.

For the wanted signal at the assigned channel frequency and two interfering signals at the RIB, using the parameters in tables 10.8.2.2-1 and 10.8.2.2-2, the following requirements shall be met:

- For any E-UTRA carrier, the throughput shall be  $\geq 95$  % of the *maximum throughput* of the reference measurement channel defined in 3GPP TS 36.104 [8], subclause 7.2.1.
- For any UTRA FDD carrier, the BER shall not exceed 0,001 for the reference measurement channel defined in 3GPP TS 25.104 [6], subclause 7.2.1.
- For any NR carrier, the throughput shall be  $\geq 95\%$  of the maximum throughput of the reference measurement channel defined in TS 38.104 [17], subclause 7.2.

The OTA levels are applied referenced to 2 antenna gain offsets  $\Delta_{\text{OTAREFSENS}}$  and  $\Delta_{\text{minSENS}}$ .

**Table 10.8.2.2-1: General narrowband intermodulation requirement**

Base Station Type	Mean power of interfering signals [dBm]	Wanted Signal mean power [dBm] (NOTE)	Type of interfering signals
Wide Area BS	$-52 - \Delta_{\text{OTAREFSENS}}$	$\text{EIS}_{\text{REFSENS}} + 6 \text{ dB}$	See table 10.8.2.2-2
	$-52 - \Delta_{\text{minSENS}}$	$\text{EIS}_{\text{minSENS}} + 6 \text{ dB}$	
Medium Range BS	$-47 - \Delta_{\text{OTAREFSENS}}$	$\text{EIS}_{\text{REFSENS}} + 6 \text{ dB}$	
	$-47 - \Delta_{\text{minSENS}}$	$\text{EIS}_{\text{minSENS}} + 6 \text{ dB}$	
Local Area BS	$-44 - \Delta_{\text{OTAREFSENS}}$	$\text{EIS}_{\text{REFSENS}} + 6 \text{ dB}$	
	$-44 - \Delta_{\text{minSENS}}$	$\text{EIS}_{\text{minSENS}} + 6 \text{ dB}$	
NOTE	$\text{EIS}_{\text{REFSENS}}$ and $\text{EIS}_{\text{minSENS}}$ depend on the RAT, the BS class and on the <i>channel bandwidth</i> , see subclauses 10.3 and 10.2.		

**Table 10.8.2.2-2: Interfering signals for narrowband intermodulation requirement**

RAT of the carrier adjacent to the upper/lower Base Station RF Bandwidth edge or edge of the sub-block	CW or 1RB interfering signal centre frequency offset from the Base Station RF Bandwidth edge or edge of sub-block inside a gap [kHz]	Type of interfering signal
E-UTRA 1.4 MHz	$\pm 260$ (BC1 and BC3) / $\pm 270$ (BC2)	CW
	$\pm 970$ (BC1 and BC3) / $\pm 790$ (BC2)	1,4 MHz E-UTRA signal, 1 RB (NOTE 1)
E-UTRA 3 MHz	$\pm 260$ (BC1 and BC3) / $\pm 270$ (BC2)	CW
	$\pm 960$ (BC1 and BC3) / $\pm 780$ (BC2)	3,0 MHz E-UTRA signal, 1 RB (NOTE 1)
E-UTRA 5 MHz	$\pm 360$	CW
	$\pm 1\ 060$	5 MHz E-UTRA signal, 1 RB (NOTE 1)
E-UTRA 10 MHz (NOTE 2)	$\pm 325$	CW
	$\pm 1\ 240$	5 MHz E-UTRA signal, 1 RB (NOTE 1)
E-UTRA 15 MHz (NOTE 2)	$\pm 380$	CW
	$\pm 1\ 600$	5MHz E-UTRA signal, 1 RB (NOTE 1)
E-UTRA 20 MHz (NOTE 2)	$\pm 345$	CW
	$\pm 1\ 780$	5MHz E-UTRA signal, 1 RB (NOTE 1)
UTRA FDD	$\pm 345$ (BC1 and BC2)	CW
	$\pm 1\ 780$ (BC1 and BC2)	5MHz E-UTRA signal, 1 RB (NOTE 1)
GSM/EDGE	$\pm 340$	CW
	$\pm 880$	5MHz E-UTRA signal, 1 RB (NOTE 1)
1,28 Mcps UTRA TDD	$\pm 190$ (BC3)	CW
	$\pm 970$ (BC3)	1,4 MHz E-UTRA signal, 1 RB (NOTE 1)
NR 5 MHz	$\pm 360$	CW
	$\pm 1420$	E-UTRA signal, 1 RB (NOTE 1)
NR 10 MHz	$\pm 325$	CW
	$\pm 1780$	E-UTRA signal, 1 RB (NOTE 1)
NR 15 MHz (Note 2)	$\pm 380$	CW
	$\pm 1600$	E-UTRA signal, 1 RB (NOTE 1)
NR 20 MHz (Note 2)	$\pm 345$	CW
	$\pm 1780$	E-UTRA signal, 1 RB (NOTE 1)
NR 25 MHz (Note 2)	$\pm 325$	CW
	$\pm 1990$	E-UTRA signal, 1 RB (NOTE 1)
NR 30 MHz (Note 2)	$\pm 320$	CW
	$\pm 1990$	E-UTRA signal, 1 RB (NOTE 1)
NR 35 MHz (Note 2)	$\pm 355$	CW
	$\pm 2350$	E-UTRA signal, 1 RB (NOTE 1)
NR 40 MHz (Note 2)	$\pm 310$	CW
	$\pm 2710$	E-UTRA signal, 1 RB (NOTE 1)
NR 45 MHz (Note 2)	$\pm 365$	CW
	$\pm 2710$	E-UTRA signal, 1 RB (NOTE 1)
NR 50 MHz (Note 2)	$\pm 330$	CW
	$\pm 3250$	E-UTRA signal, 1 RB (NOTE 1)
NR 60 MHz (Note 2)	$\pm 350$	CW
	$\pm 3790$	E-UTRA signal, 1 RB (NOTE 1)
NR 70 MHz (Note 2)	$\pm 400$	CW
	$\pm 4870$	E-UTRA signal, 1 RB (NOTE 1)
NR 80 MHz (Note 2)	$\pm 390$	CW
	$\pm 4870$	E-UTRA signal, 1 RB (NOTE 1)
NR 90 MHz (Note 2)	$\pm 340$	CW
	$\pm 5770$	E-UTRA signal, 1 RB (NOTE 1)
NR 100 MHz (Note 2)	$\pm 340$	CW
	$\pm 5770$	E-UTRA signal, 1 RB (NOTE 1)

RAT of the carrier adjacent to the upper/lower Base Station RF Bandwidth edge or edge of the sub-block	CW or 1RB interfering signal centre frequency offset from the Base Station RF Bandwidth edge or edge of sub-block inside a gap [kHz]	Type of interfering signal
NOTE 1: Interfering signal consisting of one resource block positioned at the stated offset, the channel bandwidth of the interfering signal is located adjacently to the Base Station RF Bandwidth edge.		
NOTE 2: This requirement shall apply only for an E-UTRA FRC A1-3 mapped to the frequency range at the channel edge adjacent to the interfering signals		

### 10.8.3 Minimum requirement for single RAT UTRA operation

The static reference performance as specified in subclause 10.3 and 10.2 shall be met for a Wide Area BS when the signals in table 10.8.3-1 and table 10.8.3-2 are at the RIB.

The static reference performance as specified in subclause 10.3 and 10.2 shall be met for a Medium range BS when the signals in table 10.8.3-3 and table 10.8.3-4 are at the RIB.

The static reference performance as specified in subclause 10.3 and 10.2 shall be met for a Local Area BS when the signals in table 10.8.3-5 and table 10.8.3-6 are at the RIB.

For RIB supporting operation in *non-contiguous spectrum* within each supported operating band, the requirement applies in addition inside any *sub-block gap* in case the *sub-block gap* is at least is at least 6.8MHz. The CW interfering signal offset is defined relative to the lower/upper *sub-block* edge inside the *sub-block gap* and is equal to -1MHz/+1MHz, respectively. The GMSK modulated interfering signal offset is defined relative to the lower/upper *sub-block* edge inside the *sub-block gap* and is equal to -3.4MHz/+3.4MHz, respectively.

For *multi-band RIBs*, the requirement applies in addition inside any *Inter RF Bandwidth gap*, in case the *Inter RF Bandwidth gap* size is at least 6.8MHz. The CW interfering signal offset is defined relative to lower/upper *Base Station RF Bandwidth edges* inside the *Inter RF Bandwidth gap* and is equal to -1MHz/+1MHz, respectively. The GMSK modulated interfering signal offset is defined relative to lower/upper *Base Station RF Bandwidth edges* inside the *Inter RF Bandwidth gap* and is equal to -3.4MHz/+3.4MHz, respectively.

The OTA levels are applied referenced to 2 antenna gain offsets  $\Delta_{\text{OTAREFSENS}}$  and  $\Delta_{\text{minSENS}}$ .

**Table 10.8.3-1: Intermodulation performance requirement (Wide Area BS)**

Operating band	Mean power of interfering signals [dBm]	Wanted Signal mean power [dBm] (NOTE)	Offset	Type of Interfering Signals
All bands	$-48 - \Delta_{\text{OTAREFSENS}}$	$-115 - \Delta_{\text{OTAREFSENS}}$	$\pm 10$ MHz	CW signal
	$-48 - \Delta_{\text{minSENS}}$	$-115 - \Delta_{\text{minSENS}}$		
	$-48 - \Delta_{\text{OTAREFSENS}}$	$-115 - \Delta_{\text{OTAREFSENS}}$	$\pm 20$ MHz	WCDMA signal (NOTE)
	$-48 - \Delta_{\text{minSENS}}$	$-115 - \Delta_{\text{minSENS}}$		
NOTE: The characteristics of the WCDMA interference signal are specified in 3GPP TS 25.104 [6] Annex C.				

**Table 10.8.3-2: Narrowband intermodulation performance requirement (Wide Area BS)**

Operating band	Mean power of interfering signals [dBm]	Wanted Signal mean power [dBm] (NOTE)	Offset	Type of Interfering Signals
II, III, IV, V, VIII, X, XII, XIII, XIV, XXV, XXVI	$-47 - \Delta_{\text{OTAREFSENS}}$	$-115 - \Delta_{\text{OTAREFSENS}}$	$\pm 3.5$ MHz	CW signal
	$-47 - \Delta_{\text{minSENS}}$	$-115 - \Delta_{\text{minSENS}}$		
	$-47 - \Delta_{\text{OTAREFSENS}}$	$-115 - \Delta_{\text{OTAREFSENS}}$	$\pm 5.9$ MHz	GMSK modulated (NOTE)
	$-47 - \Delta_{\text{minSENS}}$	$-115 - \Delta_{\text{minSENS}}$		
NOTE: GMSK as defined in TS45.004 [26]				

**Table 10.8.3-3: Intermodulation performance requirement (Medium Range BS)**

Operating band	Mean power of interfering signals [dBm]	Wanted Signal mean power [dBm] (NOTE)	Offset	Type of Interfering Signals
All bands	$-44 - \Delta_{OTAREFSENS}$	$-105 - \Delta_{OTAREFSENS}$	$\pm 10$ MHz	CW signal
	$-44 - \Delta_{minSENS}$	$-105 - \Delta_{minSENS}$		
	$-44 - \Delta_{OTAREFSENS}$	$-105 - \Delta_{OTAREFSENS}$	$\pm 20$ MHz	WCDMA signal (NOTE)
	$-44 - \Delta_{minSENS}$	$-105 - \Delta_{minSENS}$		
NOTE: The characteristics of the WCDMA interference signal are specified in 3GPP TS 25.104 [6] Annex C.				

**Table 10.8.3-4: Narrowband intermodulation performance requirement (Medium Range BS)**

Operating band	Mean power of interfering signals [dBm]	Wanted Signal mean power [dBm] (NOTE)	Offset	Type of Interfering Signals
II, III, IV, V, VIII, X, XII, XIII, XIV, XXV, XXVI	$-43 - \Delta_{OTAREFSENS}$	$-105 - \Delta_{OTAREFSENS}$	$\pm 3.5$ MHz	CW signal
	$-43 - \Delta_{minSENS}$	$-105 - \Delta_{minSENS}$		
	$-43 - \Delta_{OTAREFSENS}$	$-105 - \Delta_{OTAREFSENS}$	$\pm 5.9$ MHz	GMSK modulated (NOTE)
	$-43 - \Delta_{minSENS}$	$-105 - \Delta_{minSENS}$		
NOTE: GMSK as defined in TS45.004 [26]				

**Table 10.8.3-5: Intermodulation performance requirement (Local Area BS)**

Operating band	Mean power of interfering signals [dBm]	Wanted Signal mean power [dBm] (NOTE)	Offset	Type of Interfering Signals
All bands	$-38 - \Delta_{OTAREFSENS}$	$-101 - \Delta_{OTAREFSENS}$	$\pm 10$ MHz	CW signal
	$-38 - \Delta_{minSENS}$	$-101 - \Delta_{minSENS}$		
	$-38 - \Delta_{OTAREFSENS}$	$-101 - \Delta_{OTAREFSENS}$	$\pm 20$ MHz	WCDMA signal (NOTE)
	$-38 - \Delta_{minSENS}$	$-101 - \Delta_{minSENS}$		
NOTE: The characteristics of the WCDMA interference signal are specified in 3GPP TS 25.104 [6] Annex C.				

**Table 10.8.3-6: Narrowband intermodulation performance requirement (Local Area BS)**

Operating band	Mean power of interfering signals [dBm]	Wanted Signal mean power [dBm] (NOTE)	Offset	Type of Interfering Signal
II, III, IV, V, VIII, X, XII, XIII, XIV, XXV, XXVI	$-38 - \Delta_{OTAREFSENS}$	$-101 - \Delta_{OTAREFSENS}$	$\pm 3.5$ MHz	CW signal
	$-38 - \Delta_{minSENS}$	$-101 - \Delta_{minSENS}$		
	$-38 - \Delta_{OTAREFSENS}$	$-101 - \Delta_{OTAREFSENS}$	$\pm 5.9$ MHz	GMSK modulated (NOTE)
	$-38 - \Delta_{minSENS}$	$-101 - \Delta_{minSENS}$		
NOTE: GMSK as defined in TS45.004 [26]				

## 10.8.4 Minimum requirement for single RAT E- UTRA operation

For E-UTRA, the throughput shall be  $\geq 95\%$  of the *maximum throughput* of the reference measurement channel, with a wanted signal at the assigned channel frequency and two interfering signals at the RIB, with the conditions specified in tables 10.8.4-1 and 10.8.4-2 for intermodulation performance and in tables 10.8.4-3, 10.8.4-4, and 10.8.4-5 for narrowband intermodulation performance. Narrowband intermodulation requirements are not applied for Band 46 nor for Band 49. The reference measurement channel for the wanted signal is identified in table 10.8.4-1 to 6 for each *channel bandwidth* and further specified in 3GPP TS 36.104 [8] Annex A.

The receiver intermodulation requirement is applicable outside the *Base Station RF Bandwidth* or *Radio Bandwidth edges*. The interfering signal offset is defined relative to the *Base Station RF Bandwidth edges* or *Radio Bandwidth edges*.

For RIB supporting operation in *non-contiguous spectrum* within each supported operating band, the requirement applies in addition inside any *sub-block gap* in case the *sub-block gap* is at least as wide as the *channel bandwidth* of

the E-UTRA interfering signal in table 10.8.4-3. The interfering signal offset is defined relative to the *sub-block* edges inside the *sub-block gap*.

For *multi-band RIBs*, the intermodulation requirement applies in addition inside any *Inter RF Bandwidth gap*, in case the gap size is at least as wide as the E-UTRA interfering signal centre frequency offset from the *Base Station RF Bandwidth edge*.

For *multi-band RIBs*, the narrowband intermodulation requirement applies in addition inside any *Inter RF Bandwidth gap*, in case the gap size is at least as wide as the E-UTRA interfering signal in tables 10.8.4-3, 10.8.4-4 and 10.8.4-5. The interfering signal offset is defined relative to the *Base Station RF Bandwidth edges* inside the *Inter RF Bandwidth gap*.

The OTA levels are applied referenced to 2 antenna gain offsets  $\Delta_{\text{OTAREFSENS}}$  and  $\Delta_{\text{minSENS}}$ .

**Table 10.8.4-1: Intermodulation performance requirement for E-UTRA**

BS type	Wanted signal mean power [dBm]	Interfering signal mean power [dBm] (NOTE)	Type of interfering signal
Wide Area BS	$EIS_{\text{REFSENS}} + 6\text{dB}$	$-52 - \Delta_{\text{OTAREFSENS}}$	See table 10.8.4-2
	$EIS_{\text{minSENS}} + 6\text{dB}$	$-52 - \Delta_{\text{minSENS}}$	
Medium Range BS	$EIS_{\text{REFSENS}} + 6\text{dB}$	$-47 - \Delta_{\text{OTAREFSENS}}$	
	$EIS_{\text{minSENS}} + 6\text{dB}$	$-47 - \Delta_{\text{minSENS}}$	
Local Area BS	$EIS_{\text{REFSENS}} + 6\text{dB}$	$-44 - \Delta_{\text{OTAREFSENS}}$	
	$EIS_{\text{minSENS}} + 6\text{dB}$	$-44 - \Delta_{\text{minSENS}}$	
NOTE: $EIS_{\text{REFSENS}}$ and $EIS_{\text{minSENS}}$ depend on the RAT, the BS class and on the <i>channel bandwidth</i> , see subclauses 10.3 and 10.2.			

**Table 10.8.4-2: Interfering signal for Intermodulation performance requirement for E-UTRA**

E-UTRA <i>channel bandwidth</i> of the lowest/highest carrier received [MHz]	Interfering signal centre frequency offset from the lower/upper <i>Base Station RF Bandwidth edge</i> [MHz]	Type of interfering signal
3	$\pm 4.5$	CW
	$\pm 10.5$	3 MHz E-UTRA signal (NOTE 3)
5	$\pm 7.5$	CW
	$\pm 17.5$	5 MHz E-UTRA signal
10	$\pm 7.375$	CW
	$\pm 17.5$	5 MHz E-UTRA signal
15	$\pm 7.25$	CW
	$\pm 17.5$	5 MHz E-UTRA signal
20	$\pm 7.125$	CW
	$\pm 17.5$	5 MHz E-UTRA signal (NOTE 1)
NOTE 1: This type of interfering signal is not applied for Band 46 nor for Band 49.		
NOTE 2: Void		
NOTE 3: 3 MHz <i>channel bandwidth</i> is not applicable to guard band operation.		

Table 10.8.4-3: Narrowband intermodulation performance requirement for Wide Area BS for E-UTRA

E-UTRA channel bandwidth of the lowest/highest carrier received [MHz]	Wanted signal mean power [dBm] (NOTE 1)	Interfering signal mean power [dBm]	Interfering RB centre frequency offset from the lower/upper Base Station RF Bandwidth edge or sub-block edge inside a sub-block gap [kHz]	Type of interfering signal
1.4	$EIS_{REFSENS} + 6dB$	$-52 - \Delta_{OTAREFSENS}$	$\pm 270$	CW
	$EIS_{minSENS} + 6 dB$	$-52 - \Delta_{minSENS}$		
	$EIS_{REFSENS} + 6dB$	$-52 - \Delta_{OTAREFSENS}$	$\pm 790$	1.4 MHz E-UTRA signal, 1 RB (NOTE 2)
	$EIS_{minSENS} + 6 dB$	$-52 - \Delta_{minSENS}$		
3	$EIS_{REFSENS} + 6dB$	$-52 - \Delta_{OTAREFSENS}$	$\pm 270$	CW
	$EIS_{minSENS} + 6 dB$	$-52 - \Delta_{minSENS}$		
	$EIS_{REFSENS} + 6dB$	$-52 - \Delta_{OTAREFSENS}$	$\pm 780$	3.0 MHz E-UTRA signal, 1 RB (NOTE 2)
	$EIS_{minSENS} + 6 dB$	$-52 - \Delta_{minSENS}$		
5	$EIS_{REFSENS} + 6dB$	$-52 - \Delta_{OTAREFSENS}$	$\pm 360$	CW
	$EIS_{minSENS} + 6 dB$	$-52 - \Delta_{minSENS}$		
	$EIS_{REFSENS} + 6dB$	$-52 - \Delta_{OTAREFSENS}$	$\pm 1060$	5 MHz E-UTRA signal, 1 RB (NOTE 2)
	$EIS_{minSENS} + 6 dB$	$-52 - \Delta_{minSENS}$		
10 (NOTE 3)	$EIS_{REFSENS} + 6dB$	$-52 - \Delta_{OTAREFSENS}$	$\pm 325$	CW
	$EIS_{minSENS} + 6 dB$	$-52 - \Delta_{minSENS}$		
	$EIS_{REFSENS} + 6dB$	$-52 - \Delta_{OTAREFSENS}$	$\pm 1240$	5 MHz E-UTRA signal, 1 RB (NOTE 2)
	$EIS_{minSENS} + 6 dB$	$-52 - \Delta_{minSENS}$		
15 (NOTE 3)	$EIS_{REFSENS} + 6dB$	$-52 - \Delta_{OTAREFSENS}$	$\pm 380$	CW
	$EIS_{minSENS} + 6 dB$	$-52 - \Delta_{minSENS}$		
	$EIS_{REFSENS} + 6dB$	$-52 - \Delta_{OTAREFSENS}$	$\pm 1600$	5MHz E-UTRA signal, 1 RB (NOTE 2)
	$EIS_{minSENS} + 6 dB$	$-52 - \Delta_{minSENS}$		
20 (NOTE 3)	$EIS_{REFSENS} + 6dB$	$-52 - \Delta_{OTAREFSENS}$	$\pm 345$	CW
	$EIS_{minSENS} + 6 dB$	$-52 - \Delta_{minSENS}$		
	$EIS_{REFSENS} + 6dB$	$-52 - \Delta_{OTAREFSENS}$	$\pm 1780$	5MHz E-UTRA signal, 1 RB (NOTE 2)
	$EIS_{minSENS} + 6 dB$	$-52 - \Delta_{minSENS}$		
NOTE 1: $EIS_{REFSENS}$ and $EIS_{minSENS}$ depend on the RAT, the BS class and on the channel bandwidth, see subclauses 10.3 and 10.2.				
NOTE 2: Interfering signal consisting of one resource block positioned at the stated offset, the channel bandwidth of the interfering signal is located adjacently to the lower/upper Base Station RF Bandwidth edge.				
NOTE 3: This requirement shall apply only for a FRC A1-3 mapped to the frequency range at the channel edge adjacent to the interfering signals				

Table 7.8.1-4: Narrowband intermodulation performance requirement for Local Area BS for E-UTRA

E-UTRA channel bandwidth of the lowest/highest carrier received [MHz]	Wanted signal mean power [dBm] (NOTE 1)	Interfering signal mean power [dBm]	Interfering RB centre frequency offset from the lower/upper Base Station RF Bandwidth edge or sub-block edge inside a sub-block gap [kHz]	Type of interfering signal
1.4	$EIS_{REFSENS} + 6\text{dB}$	$-44 - \Delta_{OTAREFSENS}$	$\pm 270$	CW
	$EIS_{minSENS} + 6\text{dB}$	$-44 - \Delta_{minSENS}$		
	$EIS_{REFSENS} + 6\text{dB}$	$-44 - \Delta_{OTAREFSENS}$	$\pm 790$	1.4 MHz E-UTRA signal, 1 RB (NOTE 2)
	$EIS_{minSENS} + 6\text{dB}$	$-44 - \Delta_{minSENS}$		
3	$EIS_{REFSENS} + 6\text{dB}$	$-44 - \Delta_{OTAREFSENS}$	$\pm 270$	CW
	$EIS_{minSENS} + 6\text{dB}$	$-44 - \Delta_{minSENS}$		
	$EIS_{REFSENS} + 6\text{dB}$	$-44 - \Delta_{OTAREFSENS}$	$\pm 780$	3.0 MHz E-UTRA signal, 1 RB (NOTE 2)
	$EIS_{minSENS} + 6\text{dB}$	$-44 - \Delta_{minSENS}$		
5	$EIS_{REFSENS} + 6\text{dB}$	$-44 - \Delta_{OTAREFSENS}$	$\pm 360$	CW
	$EIS_{minSENS} + 6\text{dB}$	$-44 - \Delta_{minSENS}$		
	$EIS_{REFSENS} + 6\text{dB}$	$-44 - \Delta_{OTAREFSENS}$	$\pm 1060$	5 MHz E-UTRA signal, 1 RB (NOTE 2)
	$EIS_{minSENS} + 6\text{dB}$	$-44 - \Delta_{minSENS}$		
10 (NOTE 3)	$EIS_{REFSENS} + 6\text{dB}$	$-44 - \Delta_{OTAREFSENS}$	$\pm 325$	CW
	$EIS_{minSENS} + 6\text{dB}$	$-44 - \Delta_{minSENS}$		
	$EIS_{REFSENS} + 6\text{dB}$	$-44 - \Delta_{OTAREFSENS}$	$\pm 1240$	5 MHz E-UTRA signal, 1 RB (NOTE 2)
	$EIS_{minSENS} + 6\text{dB}$	$-44 - \Delta_{minSENS}$		
15 (NOTE 3)	$EIS_{REFSENS} + 6\text{dB}$	$-44 - \Delta_{OTAREFSENS}$	$\pm 380$	CW
	$EIS_{minSENS} + 6\text{dB}$	$-44 - \Delta_{minSENS}$		
	$EIS_{REFSENS} + 6\text{dB}$	$-44 - \Delta_{OTAREFSENS}$	$\pm 1600$	5MHz E-UTRA signal, 1 RB (NOTE 2)
	$EIS_{minSENS} + 6\text{dB}$	$-44 - \Delta_{minSENS}$		
20 (NOTE 3)	$EIS_{REFSENS} + 6\text{dB}$	$-44 - \Delta_{OTAREFSENS}$	$\pm 345$	CW
	$EIS_{minSENS} + 6\text{dB}$	$-44 - \Delta_{minSENS}$		
	$EIS_{REFSENS} + 6\text{dB}$	$-44 - \Delta_{OTAREFSENS}$	$\pm 1780$	5MHz E-UTRA signal, 1 RB (NOTE 2)
	$EIS_{minSENS} + 6\text{dB}$	$-44 - \Delta_{minSENS}$		
NOTE 1: $EIS_{REFSENS}$ and $EIS_{minSENS}$ depend on the RAT, the BS class and on the channel bandwidth, see subclauses 10.3 and 10.2.				
NOTE 2: Interfering signal consisting of one resource block positioned at the stated offset, the channel bandwidth of the interfering signal is located adjacently to the lower/upper Base Station RF Bandwidth edge.				
NOTE 3: This requirement shall apply only for a FRC A1-3 mapped to the frequency range at the channel edge adjacent to the interfering signals				

**Table 10.8.4-5: Narrowband intermodulation performance requirement for Medium Range BS for E-UTRA**

E-UTRA channel bandwidth of the lowest/highest carrier received [MHz]	Wanted signal mean power [dBm] (NOTE 1)	Interfering signal mean power [dBm]	Interfering RB centre frequency offset from the lower/upper Base Station RF Bandwidth edge or sub-block edge inside a sub-block gap [kHz]	Type of interfering signal
1.4	$EIS_{REFSENS} + 6\text{dB}$	$-47 - \Delta_{OTAREFSENS}$	$\pm 270$	CW
	$EIS_{minSENS} + 6\text{dB}$	$-47 - \Delta_{minSENS}$		
	$EIS_{REFSENS} + 6\text{dB}$	$-47 - \Delta_{OTAREFSENS}$	$\pm 790$	1.4 MHz E-UTRA signal, 1 RB (NOTE 2)
	$EIS_{minSENS} + 6\text{dB}$	$-47 - \Delta_{minSENS}$		
3	$EIS_{REFSENS} + 6\text{dB}$	$-47 - \Delta_{OTAREFSENS}$	$\pm 270$	CW
	$EIS_{minSENS} + 6\text{dB}$	$-47 - \Delta_{minSENS}$		
	$EIS_{REFSENS} + 6\text{dB}$	$-47 - \Delta_{OTAREFSENS}$	$\pm 780$	3.0 MHz E-UTRA signal, 1 RB (NOTE 2)
	$EIS_{minSENS} + 6\text{dB}$	$-47 - \Delta_{minSENS}$		
5	$EIS_{REFSENS} + 6\text{dB}$	$-47 - \Delta_{OTAREFSENS}$	$\pm 360$	CW
	$EIS_{minSENS} + 6\text{dB}$	$-47 - \Delta_{minSENS}$		
	$EIS_{REFSENS} + 6\text{dB}$	$-47 - \Delta_{OTAREFSENS}$	$\pm 1060$	5 MHz E-UTRA signal, 1 RB (NOTE 2)
	$EIS_{minSENS} + 6\text{dB}$	$-47 - \Delta_{minSENS}$		
10 (NOTE 3)	$EIS_{REFSENS} + 6\text{dB}$	$-47 - \Delta_{OTAREFSENS}$	$\pm 325$	CW
	$EIS_{minSENS} + 6\text{dB}$	$-47 - \Delta_{minSENS}$		
	$EIS_{REFSENS} + 6\text{dB}$	$-47 - \Delta_{OTAREFSENS}$	$\pm 1240$	5 MHz E-UTRA signal, 1 RB (NOTE 2)
	$EIS_{minSENS} + 6\text{dB}$	$-47 - \Delta_{minSENS}$		
15 (NOTE 3)	$EIS_{REFSENS} + 6\text{dB}$	$-47 - \Delta_{OTAREFSENS}$	$\pm 380$	CW
	$EIS_{minSENS} + 6\text{dB}$	$-47 - \Delta_{minSENS}$		
	$EIS_{REFSENS} + 6\text{dB}$	$-47 - \Delta_{OTAREFSENS}$	$\pm 1600$	5MHz E-UTRA signal, 1 RB (NOTE 2)
	$EIS_{minSENS} + 6\text{dB}$	$-47 - \Delta_{minSENS}$		
20 (NOTE 3)	$EIS_{REFSENS} + 6\text{dB}$	$-47 - \Delta_{OTAREFSENS}$	$\pm 345$	CW
	$EIS_{minSENS} + 6\text{dB}$	$-47 - \Delta_{minSENS}$		
	$EIS_{REFSENS} + 6\text{dB}$	$-47 - \Delta_{OTAREFSENS}$	$\pm 1780$	5MHz E-UTRA signal, 1 RB (NOTE 2)
	$EIS_{minSENS} + 6\text{dB}$	$-47 - \Delta_{minSENS}$		
NOTE 1: $EIS_{REFSENS}$ and $EIS_{minSENS}$ depend on the RAT, the BS class and on the channel bandwidth, see subclauses 10.3 and 10.2.				
NOTE 2: Interfering signal consisting of one resource block positioned at the stated offset, the channel bandwidth of the interfering signal is located adjacently to the lower/upper Base Station RF Bandwidth edge.				
NOTE 3: This requirement shall apply only for a FRC A1-3 mapped to the frequency range at the channel edge adjacent to the interfering signals				

## 10.9 OTA In-channel selectivity

### 10.9.1 General

In-channel selectivity (ICS) is a measure of the receiver unit ability to receive a wanted signal at its assigned resource block locations in the presence of an interfering signal received at a larger power spectral density. In this condition a throughput requirement shall be met for a specified reference measurement channel.

The requirement applies at the RIB when the AoA of the incident wave of a received signal and the interfering signal are from the same direction and are within the *minSENS* RoAoA.

The wanted and interfering signals apply to each supported polarization, under the assumption of *polarization match*.

### 10.9.2 Minimum requirement for MSR operation

For E-UTRA, the minimum requirement for in-channel selectivity is specified in subclause 10.9.4.

For NR, the minimum requirement for in channel selectivity is the same as that specified for *BS type I-O* in 3GPP TS 38.104 [28] in subclause 10.9.2

This requirement is not applicable for UTRA operation.

### 10.9.3 Minimum requirement for single RAT UTRA operation

This requirement is not applicable for UTRA BS.

### 10.9.4 Minimum requirement for single RAT E- UTRA operation

For E-UTRA, the throughput shall be  $\geq 95\%$  of the *maximum throughput* of the reference measurement channel as specified in 3GPP 36.104 [8] Annex A with parameters specified in table 10.9.4-1 for Wide Area BS, in table 10.9.4-2 for Local Area BS and in table 10.9.4-3 for Medium Range BS.

The OTA levels are applied referenced to  $\Delta_{\min\text{SENS}}$ .

**Table 10.9.4-1 Wide Area BS in-channel selectivity for E-UTRA**

E-UTRA channel bandwidth [MHz]	Reference measurement channel	Wanted signal mean power [dBm]	Interfering signal mean power [dBm]	Type of interfering signal
1.4	A1-4 in 3GPP 36.104 [8] Annex A.1	$-106.9 - \Delta_{\min\text{SENS}}$	$-87 - \Delta_{\min\text{SENS}}$	1.4 MHz E-UTRA signal, 3 RBs
3	A1-5 in 3GPP 36.104 [8] Annex A.1	$-102.1 - \Delta_{\min\text{SENS}}$	$-84 - \Delta_{\min\text{SENS}}$	3 MHz E-UTRA signal, 6 RBs
5	A1-2 in 3GPP 36.104 [8] Annex A.1	$-100.0 - \Delta_{\min\text{SENS}}$	$-81 - \Delta_{\min\text{SENS}}$	5 MHz E-UTRA signal, 10 RBs
10	A1-3 in 3GPP 36.104 [8] Annex A.1	$-98.5 - \Delta_{\min\text{SENS}}$	$-77 - \Delta_{\min\text{SENS}}$	10 MHz E-UTRA signal, 25 RBs
15	A1-3 in 3GPP 36.104 [8] Annex A.1 (NOTE)	$-98.5 - \Delta_{\min\text{SENS}}$	$-77 - \Delta_{\min\text{SENS}}$	15 MHz E-UTRA signal, 25 RBs (NOTE)
20	A1-3 in 3GPP 36.104 [8] Annex A.1 (NOTE)	$-98.5 - \Delta_{\min\text{SENS}}$	$-77 - \Delta_{\min\text{SENS}}$	20 MHz E-UTRA signal, 25 RBs (NOTE)

NOTE: Wanted and interfering signal are placed adjacently around  $F_c$

**Table 10.9.4-2 Local Area BS in-channel selectivity for E-UTRA**

E-UTRA channel bandwidth [MHz]	Reference measurement channel	Wanted signal mean power [dBm]	Interfering signal mean power [dBm]	Type of interfering signal
1.4	A1-4 in 3GPP 36.104 [8] Annex A.1	$-98.9 - \Delta_{\min\text{SENS}}$	$-79 - \Delta_{\min\text{SENS}}$	1.4 MHz E-UTRA signal, 3 RBs
3	A1-5 in 3GPP 36.104 [8] Annex A.1	$-94.1 - \Delta_{\min\text{SENS}}$	$-76 - \Delta_{\min\text{SENS}}$	3 MHz E-UTRA signal, 6 RBs
5	A1-2 in 3GPP 36.104 [8] Annex A.1	$-92.0 - \Delta_{\min\text{SENS}}$	$-73 - \Delta_{\min\text{SENS}}$	5 MHz E-UTRA signal, 10 RBs
10	A1-3 in 3GPP 36.104 [8] Annex A.1 (NOTE 3)	$-90.5 - \Delta_{\min\text{SENS}}$	$-69 - \Delta_{\min\text{SENS}}$	10 MHz E-UTRA signal, 25 RBs (NOTE 3)
15	A1-3 in 3GPP 36.104 [8] Annex A.1 (NOTE 1)	$-90.5 - \Delta_{\min\text{SENS}}$	$-69 - \Delta_{\min\text{SENS}}$	15 MHz E-UTRA signal, 25 RBs (NOTE 1)
20	A1-3 in 3GPP 36.104 [8] Annex A.1 (NOTE 1)	$-90.5 - \Delta_{\min\text{SENS}}$	$-69 - \Delta_{\min\text{SENS}}$	20 MHz E-UTRA signal, 25 RBs (NOTE 1)

NOTE 1: Wanted and interfering signal are placed adjacently around  $F_c$ , this reference measurement channel and interfering signal are not applied for Band 46 nor for Band 49.  
NOTE 2: Void  
NOTE 3: This reference measurement channel and interfering signal are not applied for Band 46 nor for Band 49.

Table 10.9.4-3 Medium Range BS in-channel selectivity for E-UTRA

E-UTRA channel bandwidth [MHz]	Reference measurement channel	Wanted signal mean power [dBm]	Interfering signal mean power [dBm]	Type of interfering signal
1.4	A1-4 in 3GPP 36.104 [8] Annex A.1	$-101.9 - \Delta_{\min\text{SENS}}$	$-82 - \Delta_{\min\text{SENS}}$	1.4 MHz E-UTRA signal, 3 RBs
3	A1-5 in 3GPP 36.104 [8] Annex A.1	$-97.1 - \Delta_{\min\text{SENS}}$	$-79 - \Delta_{\min\text{SENS}}$	3 MHz E-UTRA signal, 6 RBs
5	A1-2 in 3GPP 36.104 [8] Annex A.1	$-95.0 - \Delta_{\min\text{SENS}}$	$-76 - \Delta_{\min\text{SENS}}$	5 MHz E-UTRA signal, 10 RBs
10	A1-3 in 3GPP 36.104 [8] Annex A.1 (NOTE 3) A1-8 in 3GPP 36.104 [8] Annex A.1 (NOTE 2)	$-93.5 - \Delta_{\min\text{SENS}}$ $-96.2 - \Delta_{\min\text{SENS}}$	$-72 - \Delta_{\min\text{SENS}}$ $-74.8 - \Delta_{\min\text{SENS}}$	10 MHz E-UTRA signal, 25 RBs (NOTE 3) 10 MHz E-UTRA interlace signal, 10 RBs (NOTE 2)
15	A1-3 in 3GPP 36.104 [8] Annex A.1 (NOTE 1)	$-93.5 - \Delta_{\min\text{SENS}}$	$-72 - \Delta_{\min\text{SENS}}$	15 MHz E-UTRA signal, 25 RBs (NOTE 1)
20	A1-3 in 3GPP 36.104 [8] Annex A.1 (NOTE 1) A1-9 in 3GPP 36.104 [8] Annex A.1 (NOTE 2)	$-93.5 - \Delta_{\min\text{SENS}}$ $-96.2 - \Delta_{\min\text{SENS}}$	$-72 - \Delta_{\min\text{SENS}}$ $-74.8 - \Delta_{\min\text{SENS}}$	20 MHz E-UTRA signal, 25 RBs (NOTE 1) 20 MHz E-UTRA interlace signal, 10 RBs (NOTE 2)
NOTE 1: Wanted and interfering signal are placed adjacently around $F_c$ , this reference measurement channel and interfering signal are not applied for Band 46.				
NOTE 2: Wanted and interfering signal interlaces are mirrored around $F_c$ , this reference measurement channel and interfering signal are only applied for Band 46.				
NOTE 3: This reference measurement channel and interfering signal are not applied for Band 46.				

## 11 Radiated performance requirements

### 11.1 General

#### 11.1.1 OTA demodulation branches

OTA performance requirements are only specified for up to 2 *demodulation branches*.

If the OTA AAS BS uses polarization diversity and has the ability to maintain isolation between the signals for each of the *demodulation branches*, then OTA performance requirements can be tested for up to two *demodulation branches*. When tested for two *demodulation branches*, each demodulation branch maps to one polarization.

If the OTA AAS BS does not use polarization diversity then OTA performance requirements can only be tested for a single *demodulation branch*.

#### 11.1.2 UTRA operation

Performance requirements for *single RAT UTRA operation* in FDD are specified for the measurement channels defined in 3GPP TS 25.104 [2]. The requirements only apply to those measurement channels that are supported by AAS BS. For FRC8 in 3GPP TS 25.104 [2] the non E-DPCCH boosting and E-DPCCH boosting requirement only apply for the option supported by the AAS BS. The performance requirements for the high speed train scenarios defined in 3GPP TS 25.104 [2] are optional.

Unless stated otherwise, performance requirements apply for a single cell only. Performance requirements for an AAS BS supporting UTRA FDD DC-HSUPA or DB-DC-HSUPA and UTRA TDD MC\_HSUPA are defined in terms of single carrier requirements. For FDD operation the requirements in clause 11 shall be met with the transmitter unit(s) associated with the RIB in the operating band ON.

NOTE: In normal operating conditions the *transceiver units* in UTRA FDD operation are configured to transmit and receive at the same time. The transmitter unit(s) associated with the RIB may be OFF for some of the tests as specified in 3GPP TS 37.145 [13].

In the referred UTRA specifications and in this clause, the term BS with RX diversity refers to performance requirements for two *demodulation branches*, and BS without RX diversity refers to performance requirements for one *demodulation branch*.

For AAS BS with RX diversity, only the BS performance requirements with RX diversity apply, the required  $E_b/N_0$  for UTRA FDD and  $\hat{I}_{or}/I_{oc}$  for UTRA TDD shall be applied separately for each *demodulation branch*.

For AAS BS without RX diversity, only the BS performance requirements without RX diversity apply. The required  $E_b/N_0$  for UTRA FDD and  $\hat{I}_{or}/I_{oc}$  for UTRA TDD shall be applied for each AAS BS *demodulation branch*.

The  $E_b/N_0$  used for UTRA FDD is defined as:

$$E_b / N_o = \frac{E_c}{N_o} \cdot \frac{L_{chip}}{L_{inf}}$$

Where:

$E_c$  is the received total energy of DPDCH, DPCCH, S-DPCCH, HS-DPCCH, E-DPDCH, S-E-DPDCH, E-DPCCH and S-E-DPCCH per PN chip per *demodulation branch* from all branches

$N_o$  is the total one-sided noise power spectral density due to all noise sources

$L_{chip}$  is the number of chips per frame

$L_{inf}$  is the number of information bits in DTCH excluding CRC bits per frame

**Table 11.1.2-1: Summary of AAS BS performance targets for single RAT UTRA operation**

Physical channel	Measurement channel	Static	Multi-path Case 1	Multi-path Case 2	Multi-path Case 3	Moving	Birth / Death	High Speed Train
		Performance metric						
DCH	12.2 kbps	BLER<10 <sup>-2</sup>	BLER<10 <sup>-2</sup>	BLER<10 <sup>-2</sup>	BLER<10 <sup>-2</sup>	BLER<10 <sup>-2</sup>	BLER<10 <sup>-2</sup>	BLER<10 <sup>-2</sup>
	64 kbps	BLER<10 <sup>-1</sup> ,10 <sup>-2</sup>	BLER<10 <sup>-1</sup> ,10 <sup>-2</sup>	BLER<10 <sup>-1</sup> ,10 <sup>-2</sup>	BLER<10 <sup>-1</sup> ,10 <sup>-2</sup> ,10 <sup>-3</sup>	BLER<10 <sup>-1</sup> ,10 <sup>-2</sup>	BLER<10 <sup>-1</sup> ,10 <sup>-2</sup>	-
	144 kbps	BLER<10 <sup>-1</sup> ,10 <sup>-2</sup>	BLER<10 <sup>-1</sup> ,10 <sup>-2</sup>	BLER<10 <sup>-1</sup> ,10 <sup>-2</sup>	BLER<10 <sup>-1</sup> ,10 <sup>-2</sup> ,10 <sup>-3</sup>	-	-	-
	384 kbps	BLER<10 <sup>-1</sup> ,10 <sup>-2</sup>	BLER<10 <sup>-1</sup> ,10 <sup>-2</sup>	BLER<10 <sup>-1</sup> ,10 <sup>-2</sup>	BLER<10 <sup>-1</sup> ,10 <sup>-2</sup> ,10 <sup>-3</sup>	-	-	-

NOTE: In case of multiple BLER level thresholds listed for single requirement and measurement channel combination, those BLER level values are reflected by set multiple requirements in 3GPP TS 25.104 [2].

### 11.1.3 E-UTRA operation

Performance requirements for the AAS BS are specified for the fixed reference channels (FRC) and propagation conditions defined in 3GPP TS 36.104 [8] annex A and annex B, respectively. The requirements only apply to those FRCs that are supported by the AAS BS.

Unless stated otherwise, performance requirements apply for a single carrier only. Performance requirements for an AAS BS E-UTRA supporting *carrier aggregation* are defined in terms of single carrier requirements. For FDD operation the requirements shall be met with the transmitter unit(s) associated with the RIB in the operating band ON.

NOTE: In normal operating conditions the *transceiver units* in FDD operation are configured to transmit and receive at the same time. The transmitter unit(s) associated with the RIB may be OFF for some of the tests as specified in 3GPP TS 37.145 [13].

In the referred E-UTRA specification, the term "RX antennas" refers to *demodulation branches* (and not physical antennas).

The SNR used in this clause is specified based on a single carrier and defined as:

$$\text{SNR} = S / N$$

Where:

$S$  is the total signal energy in the subframe.

$N$  is the noise energy in a bandwidth corresponding to the *transmission bandwidth* over the duration of a subframe.

For enhanced performance requirements type A, the SINR used in this clause is specified based on a single carrier and defined as:

$$\text{SINR} = S / N'$$

Where:

$s$  is the total signal energy in the subframe.

$N'$  is the summation of the received energy of the strongest interferers explicitly defined in a test procedure plus the white noise energy  $N$ , in a bandwidth corresponding to the *transmission bandwidth* over the duration of a subframe. The respective energy of each interferer relative to  $N'$  is defined by its associated DIP value.

## 11.2 Minimum requirements for MSR operation

For *single RAT UTRA operation*, minimum requirements for demodulation performance are specified in subclause 8.3.

For *single RAT E-UTRA operation*, minimum requirements for demodulation performance are specified in subclause 8.4.

## 11.3 Minimum requirements for UTRA operation

The *single RAT UTRA operation* in FDD shall fulfil all mandatory BS demodulation performance requirements specified in subclauses 8.2 to 8.12 of 3GPP TS 25.104 [6].

In the referred UTRA specifications, the term BS with RX diversity refers to performance requirements for two *demodulation branches*, and BS without RX diversity refers to performance requirements for one *demodulation branch*.

## 11.4 Minimum requirements for E-UTRA operation

The *single RAT E-UTRA operation* shall fulfil all mandatory BS demodulation performance requirements specified in subclauses 8.2 - 8.4 (for PUSCH, PUCCH and PRACH) and 8.6 – 8.7 (for subslot-PUSCH and sPUCCH) of TS 36.104 [8].

In the referred E-UTRA specification, the term "RX antennas" refers to *demodulation branches* (i.e. not physical antennas).

---

## Annex A (normative): Environmental requirements for the BS equipment

The AAS BS equipment shall fulfil all the requirements in the full range of environmental conditions for the relevant environmental class. The environmental conditions and class shall be from the relevant IEC specifications or the corresponding ETSI specifications listed below.

IEC specifications for environmental requirements:

IEC 60721-3-3 [21]: "Stationary use at weather protected locations".

IEC 60721-3-4 [22]: "Stationary use at non weather protected locations".

ETSI specifications for environmental requirements:

ETSI EN 300 019-1-3 [23]: "Stationary use at weather protected locations".

ETSI EN 300 019-1-4 [24]: "Stationary use at non weather protected locations".

Normally it should be sufficient for all tests to be conducted using normal test conditions except where otherwise stated. For guidance on the use of test conditions to be used in order to show compliance refer to TS 37.145-1 [29] or TS 37.145-2 [30].

---

## Annex B (Informative): Calculation of EIRP based on fixed assumption of passive antenna gain

### B.1 Calculation of EIRP based on fixed assumption of passive antenna gain

Some regional requirements are defined per effective isotropic radiated power (EIRP), which is a combination of the transmitted power (or in some cases spectral density) and the effective antenna gain which is a site specific condition. Such requirements may be applied per antenna, per cell, or per base station. It shall be noted that the definition of BS or cell may differ between regulations. Where the regulator prescribes a method for EIRP calculation, that method supersedes the proposed assessment in this annex.

The regulations set an EIRP limit considering a passive antenna BS. Although the gain of passive antennas may vary somewhat, the gain variation is in the order of a few dBs. The instantaneous gain of an AAS BS may be much larger. However AAS unwanted emissions requirements are defined as TRP, since TRP impacts co-existence properties.

In order to relate the EIRP values in the specifications to TRP, a fixed assumption has been made on the gain of a typical passive BS antenna.

Thus, the maximum TRP can be estimated using the following formulas:

$$\text{TRP limit per antenna: } P_{\text{TRP, antenna}} = P_{\text{EIRP}} - G_{\text{Ant}}$$

$$\text{E-UTRA TRP limit per cell or per BS: } P_{\text{TRP}} = P_{\text{TRP, antenna}} + 9\text{dB}$$

$$\text{UTRA TRP limit per cell or per BS: } P_{\text{TRP}} = P_{\text{TRP, antenna}} + 6\text{dB}$$

It is noted that the AAS architecture assumes that a BS subject to OTA requirements will have at least 8 antennas.

In case the TRP requirement is set per polarisation, the summation shall be made per polarisation.

" $P_{\text{EIRP}}$ " is the effective isotropic radiated power (or radiated power spectral density) set in the regulation (assuming a passive BS antenna) in dBm (or dBm/measurement BW).

" $G_{\text{Ant}}$ " is the effective antenna gain, the antenna gain (dBi) is a fixed reference value of 17 dBi. Directivity value should be used in above equations, however with all antenna losses are assumed zero then we can use effective antenna gain.

## Annex C (informative): Change history

Change history							
Date	Meeting	TDoc	CR	Rev	Cat	Subject/Comment	New version
2015-10	RAN4#76 bis	R4-156540				Specification structure	0.0.1
2015-10	RAN4#77	R4-157517				Approved text proposals in the following documents were implemented: R4-156802 - TP - Text for TS, structure update R4-156926 - TP - Text for TS, General clauses R4-156804 - TP for TS Conducted transmitter requirements - subclause 6.5 R4-156805 - TP for TS Conducted transmitter requirements - clause 7 R4-156806 - Proposed OTA TX power TS text - clause 9 R4-156807 - TP - Text for TS, OTA sensitivity - clause 10	0.1.0
2016-02	RAN4#78	R4-161119				Approved text proposals in the following documents were implemented: R4-157316 - TP for TS37.105: correction on base station classes R4-157529 - TP - Text for TS, clean up missing references R4-157657 - TP for TS 37.105: Additions to OTA sensitivity in section 10 R4-158287 - TP for TS - clean up based on modification in section 4.9 R4-158288 - TP - Text for TS, definitions clean up. R4-158289 - TP - Text for TS, General section R4-158290 - TP - Text for TS, Section 5 R4-158291 - TP - Text for TS, Conducted Transmitter Requirements - section 6, 6.1, 6.2, 6.3, 6.4 R4-158292 - TP for 37.105: Unwanted Emissions R4-158293 - TP for TS 37.105: Radiated transmit power additions to section 9 R4-158294 - TP for TS 37.105: Adding transmitter IMD requirement text to section 6.7 R4-158295 - TP for TS 37.105: Adding receiver emission scaling to section 7.6	0.2.0
2016-02	RAN4#78	R4-161308				Approved text proposals in the following documents were implemented: R4-160932 - TP to TS 37.105 - EIRP accuracy value R4-160933 - TP to TS 37.105 - final clean up R4-160935 - TP-to TS 37.105 - add clarification of conformance requirements R4-160699 - TP for TS 37.105: Editorial corrections to radiated transmit power in clause 9 R4-161362 - TP for TS 37.105: AAS TS overall cleanup R4-161358 - TP for TS 37.105: Improvements to Radiated transmit power in section 3 and 9 R4-161364 - TP - to TS37.105 - Text amendment regarding multi-band exclusion bands for RX spurious emission R4-161363 - TP-to TS 37.105 - add annexes R4-161360 - TP for TS37.105 on UEM requirements R4-161236 - TP for 37.104: core specification design for AAS demodulation requirements R4-161495 - TP to 37.105 on Multi-band Tx/Rx TAB connector	0.3.0
2016-03	RAN#71	RP-160400				Presented to RAN for approval. Editorial cotrections recommended by ETSI editHelp	1.0.0
2016-03	RP-71					TR is approved by RAN plenary	13.0.0
06/2016	RP-72	RP-161142	2	1	F	Editorial corrections - alignment with 3GPP drafting rules	13.1.0
06/2016	RP-72	RP-161127	5	1	F	Clarifying UTRA TDD option in Performance section	13.1.0
06/2016	RP-72	RP-161142	6	-	F	Correction of interfering signal level for Tx intermodulation	13.1.0
06/2016	RP-72	RP-161142	7	1	F	Correct spectrum emission mask and operating band UEM absolute <i>basic limits</i>	13.1.0
06/2016	RP-72	RP-161142	11	1	D	37.105: Readability improvemenand corrections (sections 4 - 10)	13.1.0
09/2016	RP-73	RP-161635	15		D	TS 37.105: Readability improvements and corrections (section 3)	13.2.0
09/2016	RP-73	RP-161635	13	1	F	Correction of AAS Base Station performance targets	13.2.0
12/2016	RP-74	RP-162422	0018	1	F	MB MSR related corrections on receiver blocking	13.3.0
12/2016	RP-74	RP-162422	0020	2	D	CR to TS 37.105: Clarifications, definitions alignment and text improvements	13.3.0
12/2016	RP-74	RP-162422	0021	1	F	TS 37.105: Removal of operating band unwanted emissions for Band 46	13.3.0
12/2016	RP-74	RP-162422	0024	1	F	AAS ACLR absolute limit	13.3.0
12/2016	RP-74	RP-162422	0026	-	F	Clarification on the Rx diversity branches vs. demodulation branches terminology	13.3.0
03/2017	RP-75	RP-170586	0027	-	F	Corrections of the power range for SEM and OBUE requirement.	13.4.0

03/2017	RP-75	RP-170586	0028	1	F	TS 37.105: Alignment with legacy specifications on bands 45, 65, 66, 67, 68.	13.4.0
03/2017	RP-75	RP-170586	0029	1	F	TS 37.105: Corrections on references	13.4.0
03/2017	RP-75	RP-170586	0030	-	B	CR to TS 37.105: Isolation of the NB-IoT feature from the AAS BS specification	13.4.0
03/2017	RP-75	RP-170586	0031	1	B	CR to TS 37.105: Isolation of Band 46 from the AAS BS specification	13.4.0
03/2017	RP-75	RP-170586	0032	1	D	CR to TS 37.105: editorial corrections	13.4.0
03/2017	RP-75	RP-170586	0033	-	F	CR to TS 37.105: Rel-13 single RAT and MSR specification reference updates: MB MSR correction	13.4.0
03/2017	RP-75	-	-	-	-	Update to Rel-14 version (MCC)	14.0.0
06/2017	RP-76	RP-171305	0060	1	A	CR to TS 37.105: Correction of the spurious emissions requirement	14.1.0
06/2017	RP-76	RP-171305	0061		A	CR to TS 37.105: BS demodulation requirements update	14.1.0
06/2017	RP-76	RP-171305	0062		A	CR to TS 37.105: Addition of 1.4 and 3 MHz channel bandwidths for Band 65	14.1.0
09/2017	RP-77	RP-171968	0064		A	CR to TS 37.105: Corrections of the UTRA Inner loop power control and the frequency error requirements; Rel-14	14.2.0
09/2017	RP-77	RP-171968	0065	1	B	CR to TS 37.105: introduction of bands 48, 69, 70	14.2.0
09/2017	RP-77	RP-171968	0067		A	Transmit pulse shape filter for TDD operation	14.2.0
09/2017	RP-77	RP-171968	0068		F	CR to TS 37.105: versioned reference updates to Rel-14 non-AAS specifications	14.2.0
09/2017	RP-77	RP-171968	0070		A	CR to TS 37.105 on PS-LTE BS regional requirements for Band 28 in Korea	14.2.0
2017-12	RAN#78	RP-172599	0073		B	CR to TS 37.105: AAS RF specification, v15.0.0	15.0.0
2018-03	RAN#79	RP-180282	0074	1	F	CR to TS 37.105	15.1.0
2018-06	RAN#80	RP-181109	0077		A	CR to TS 37.105: absolute ACLR limit	15.2.0
2018-06	RAN#80	RP-181109	0081		A	CR to TS 37.105: Correction of regional requirements - removal of co-location and co-existence (4.5), Rel-15 This CR was not implemented as the changes are not based on the latest version	15.2.0
2018-06	RAN#80	RP-181109	0086		A	CR to TR 37.105: Clarifications on OTA sensitivity requirement (10.2.1)	15.2.0
2018-06	RAN#80	RP-181075	0090		B	Introduction of NR to eAAS	15.2.0
2018-09	RAN#81	RP-181896	0095	1	F	Correction on unwanted emission mask for TS 37.105	15.3.0
2018-09	RAN#81	RP-181917	0096		F	CR to TS 37.105: corrections of the regional requirements (4.5)	15.3.0
2018-09	RAN#81	RP-181917	0097		F	CR to TS 37.105: Correction of the OTA blocking requirement (10.6.2.1)	15.3.0
2018-12	RAN#82	RP-182360	0099	2	F	Corrections to AAS receiver requirements for NR	15.4.0
2018-12	RAN#82	RP-182360	0100	2	F	Addition of NR to of OTA out of band blocking requirements	15.4.0
2018-12	RAN#82	RP-182360	0101	2	F	Addition of NR to co-existence and co-location related emissions for single RAT BS	15.4.0
2018-12	RAN#82	RP-182360	0102	1	F	Correction of NR related OBUE emissions tables	15.4.0
2018-12	RAN#82	RP-182380	0108		A	CR to TS 37.105: TS37.145 reference correction, Rel-15	15.4.0
2018-12	RAN#82	RP-182386	0109		F	CR to TS 37.105: correction of the "EIRP accuracy directions set" into "OTA peak directions set"	15.4.0
2018-12	RAN#82	RP-182386	0110	1	F	CR to TS 37.105: Corrections to co-location requirements	15.4.0
2018-12	RAN#82	RP-182387	0112		F	CR to TS 37.105: Text alignment for the OTA demodulation branches	15.4.0
2018-12	RAN#82	RP-182360	0113	1	F	Correction of narrowband blocking requirement for NR	15.4.0
2018-12	RAN#82	RP-182380	0116		A	Cleanup to conducted requirements text	15.4.0
2018-12	RAN#82	RP-182386	0117	1	F	Cleanup to OTA requirements text	15.4.0
2018-12	RAN#82	RP-182387	0118	2	F	CR to TS 37.105 - polarisation wording improvements for OTA s reference sensitivity	15.4.0
2018-12	RAN#82	RP-182386	0120		F	CR for TS37.105: Clean up multi-band RIBs	15.4.0
2018-12	RAN#82	RP-182387	0121		F	CR to TS 37.105 Removal of referencing error for in-band blocking	15.4.0
2019-03	RAN#83	RP-190418	0123	3	F	Correction to definition of OTA reference sensitivity	15.5.0
2019-03	RAN#83	RP-190418	0124	1	F	Correction to TDD OFF power requirement	15.5.0
2019-03	RAN#83	RP-190412	0129	1	F	CR to TS 37.105 on Correction of unwanted emissions scaling	15.5.0
2019-03	RAN#83	RP-190418	0130		F	CR to TS 37.105: Implementation of 1024QAM for E-UTRA, Rel-15	15.5.0
2019-03	RAN#83	RP-190418	0131	1	F	CR to TS 37.105: Implementation of sTTI for E-UTRA, Rel-15	15.5.0
2019-03	RAN#83	RP-190418	0132	2	F	CR to TS 37.105: new Rel-15 bands and isolation of band 49, Tx, Rel-15	15.5.0
2019-03	RAN#83	RP-190418	0133	1	F	CR to TS 37.105: new Rel-15 bands and isolation of band 49, Rx, Rel-15	15.5.0
2019-03	RAN#83	RP-190418	0135	1	F	CR to TS37.105 Correction to OTA test requirements	15.5.0
2019-06	RAN#84	RP-191262	0136	1	F	CR to TS 37.105: Corrections on out-of-band blocking requirement	15.6.0
2019-06	RAN#84	RP-191262	0137		F	CR to TS 37.105: addition of Band 35, 36, 37 to Tx spurious colocation requirement	15.6.0
2019-06	RAN#84	RP-191262	0138		F	Corrections to operation in Band 46 and 49	15.6.0
2019-06	RAN#84	RP-191262	0140		F	Correction on $\Delta f_{OOB}$ for 37.105	15.6.0
2019-06	RAN#84	RP-191262	0141	1	F	Blocking requirement for MSR/NR operation	15.6.0
2019-06	RAN#84	RP-191262	0142		F	Correction to OTA Narrowband blocking requirement	15.6.0
2019-06	RAN#84	RP-191262	0143	1	F	Correction to out of band blocking requirement	15.6.0
2019-06	RAN#84	RP-191262	0146		F	Non-AAS CRs mirroring to the AAS specification	15.6.0

2019-06	RAN#84	RP-191236	0152	1	F	CR for TS37.105: correction on TX Diversity and CRS for NR for TAE requirement	15.6.0
2019-06	RAN#84	RP-191250	0144	1	B	n65 introduction to 37.105	16.0.0
2019-06	RAN#84	RP-191257	0147		B	CR to 37.105: Introduction of Band 87 and 88	16.0.0
2019-06	RAN#84	RP-191249	0148		B	CR to 37.105: Introduction of n48	16.0.0
2019-06	RAN#84	RP-191245	0149		B	Introduce Band n18 to 37.105	16.0.0
2019-06	RAN#84	RP-191243	0150		B	Introduction of Band n14 in TS 37.105	16.0.0
2019-06	RAN#84	RP-191247	0151		B	Introduction of Band n30 in TS 37.105	16.0.0
2019-09	RAN#85	RP-192053	0154		A	Correction to RX spurious emissions applicability range for SR E-UTRA BS	16.1.0
2019-09	RAN#85	RP-192053	0156		A	CR for TS37.105: definition of synchronization operation	16.1.0
2019-09	RAN#85	RP-192053	0158		A	CR to TS 37.105: Clarification on application of OTA receiver requirements for BS supporting polarization	16.1.0
2019-09	RAN#85	RP-192046	0162		A	CR to TS 37.105: Correction on operation band unwanted emission	16.1.0
2019-09	RAN#85	RP-192046	0164		A	CR to TS37.105 Corrections on NBB requirement (section 7.4 and 10.5)	16.1.0
2019-09	RAN#85	RP-192030	0165		F	CR on Protection of SUL band n89 to TS 37.105	16.1.0
2019-09	RAN#85	RP-192034	0166		B	n29 introduction to 37.105	16.1.0
2019-09	RAN#85	RP-192050	0170		A	CR to 37.105: correction of TAB connectors mapping to TAB connector TX min cell group, Rel-16	16.1.0
2019-12	RAN#86	RP-193014	0171		B	Introduction of 2010-2025MHz SUL band into Rel-16 TS 37.105	16.2.0
2019-12	RAN#86	RP-193037	0173		A	CR to 37.105 on Receiver spurious emission requirements	16.2.0
2019-12	RAN#86	RP-193037	0175	1	A	CR to 37.105 on Receiver Intermodulation signal offset correction	16.2.0
2019-12	RAN#86	RP-193037	0177		A	CR to TS37.105 Corrections on NBB requirement (section 7.4 and 10.5)	16.2.0
2019-12	RAN#86	RP-193048	0179		A	CR to TS 37.105: Requirement set applicability	16.2.0
2019-12	RAN#86	RP-192844	0180		B	CR to 37.105 on variable duplex FDD bands	16.2.0
2020-03	RAN#87	RP-200381	0181		B	Introduction of n26	16.3.0
2020-03	RAN#87	RP-200382	0182		B	Introduction of n53	16.3.0
2020-06	RAN#88	RP-200984	0184		F	CR to TS 37.105: removal of [], Rel-16	16.4.0
2020-09	RAN#89	RP-201512	0191		A	CR to TS 37.105: Rel-13 non-AAS CRs mirroring, Rel-16	16.5.0
2020-09	RAN#89	RP-201512	0194		A	CR to TS 37.105: Rel-14 non-AAS CRs mirroring, Rel-16	16.5.0
2020-09	RAN#89	RP-201512	0196		A	CR to TS 37.105: Rel-15 non-AAS CRs mirroring, Rel-16	16.5.0
2020-09	RAN#89	RP-201512	0197		F	CR to TS 37.105: Rel-15 non-AAS CRs mirroring, Rel-15	16.5.0
2020-09	RAN#89	RP-201512	0199		B	CR to 37.105: Introduction of NR-U co-existence requirements	16.5.0
2020-12	RAN#90	RP-202510	0206		A	CR to TS 37.105: Corrections to core requirements including UEM additional requirements, Rel-16	16.6.0
2020-12	RAN#90	RP-202414	0207		B	CR to 37.105: Introduction of n96 medium range requirements	16.6.0
2020-12	RAN#90	RP-202510	0209		A	CR to 37.105 on Removal of additional limit for Band 1	16.6.0
2020-12	RAN#90	RP-202510	0213		A	CR to TS 37.105: addition of the OBUE applicability table, Rel-16	16.6.0
2020-12	RAN#90	RP-202451	0200		B	Introduction of 1880-1920MHz SUL band into Rel-17 TS 37.105	17.0.0
2020-12	RAN#90	RP-202452	0201		B	Introduction of 2300-2400MHz SUL band into Rel-17 TS 37.105	17.0.0
2020-12	RAN#90	RP-202448	0203		B	CR to TS 37.105: introduction of NR band n13	17.0.0
2021-03	RAN#91e	RP-210097	0214		B	CR for 37.105 Introduction of NR band n24	17.1.0
2021-03	RAN#91e	RP-210096	0216		B	CR for TS 37.105 Introduction of SUL for UL of NR band n24	17.1.0
2021-03	RAN#91	RP-210110	0218		A	CR for 37.105: Corrections related to Band 24 regulatory updates	17.1.0
2021-03	RAN#91e	RP-210118	0223		A	CR to TS 37.105: Introduction of new BS capability set for NR+EUTRA+UTRA, Rel-17	17.1.0
2021-06	RAN#92	RP-211076	0232		A	CR to TS 37.105: Regional requirements for band 41 in Japan, Rel-17	17.2.0
2021-06	RAN#92	RP-211116	0233		B	CR to TS 37.105: Introduction of band n67	17.2.0
2021-06	RAN#92	RP-211116	0234	1	B	CR to TS 37.105: Introduction of band n85	17.2.0
2021-06	RAN#92	RP-211090	0238		A	CR to 37.105: In-band blocking for multi-band Base Stations	17.2.0
2021-09	RAN#93	RP-211909	0239		B	CR to TS 37.105: Introduction of 35 MHz and 45 MHz	17.3.0
2021-09	RAN#93	RP-211925	0242		A	Big CR for TS 37.105 Maintenance (Rel-17, CAT A)	17.3.0
2021-12	RAN#94	RP-212853	0246		A	Big CR for TS 37.105 Maintenance (Rel-17, CAT A)	17.4.0
2022-03	RAN#95	RP-220357	0249		B	CR for 37.105 on Introduction of lower 6GHz NR unlicensed operation for Europe	17.5.0
2022-03	RAN#95	RP-220347	0248	1	B	CR to TS37.105 on introduction of upper 700MHz A block	17.5.0
2022-03	RAN#95	RP-220331	0252		A	Big CR for TS 37.105 Maintenance (Rel-17, CAT A)	17.5.0
2022-03	RAN#95	RP-220376	0253		B	CR to TS 37.105: RMR 1900MHz band n101 introduction	17.5.0
2022-06	RAN#96	RP-221684	0255		B	CR to TS 37.105: introduction of n100 co-existence requirements, Rel-17	17.6.0
2022-06	RAN#96	RP-221673	0254	1	B	Introducing 6GHz licensed operation into 37.105	17.6.0
2022-06	RAN#96	RP-221652	0258		A	Big CR for TS 37.105 Maintenance (Rel-17, CAT A)	17.6.0
2023-03	RAN#99	RP-230500	0262		A	CR to TS 37.105: The applicability of additional BC3 requirements	17.7.0
2023-03	RAN#99	RP-230500	0265		A	CR to 37.105: Operating band unwanted emission requirements	17.7.0
2023-03	RAN#99	RP-230503	0271		A	CR to TS 37.105 - Wrong reference to NR additional spurious requirement	17.7.0
2023-06	RAN#100	RP-231352	0276		A	CR to 37.105: Clarification on the OBUE limites when narrow carrier adjacent to the sub block edge	17.8.0

2024-03	RAN#103	RP-240553	0281	1	F	(TE117) CR to TS 37.105 - BS spurious receiver protection note generalization R17	17.9.0
2024-03	RAN#103	RP-240554	0285		A	(AAS_BS_LTE_UTRA-Core) CR to TS 37.105: Correction of OBUE requirement applicability in Table 6.6.5.2.2-0	17.9.0
2024-06	RAN#104	RP-241389	0289		A	(AAS_BS_LTE_UTRA-Core) CR to TS 37.105 on correction for single RAT E-UTRA operation	17.10.0
2024-12	RAN#106	RP-243067	0291	1	F	(TE117) CR to TS 37.105 - BS spurious receiver protection note [MSR_BSRF_RX]	17.11.0
2025-09	RAN#109	RP-252377	0301		A	(AASenh_BS_LTE_UTRA-Core) CR to 37.105: Additional co-location requiremen for BC1 and BC2	17.12.0

---

# History

<b>Document history</b>		
V17.5.0	April 2022	Publication
V17.6.0	July 2022	Publication
V17.7.0	April 2023	Publication
V17.8.0	July 2023	Publication
V17.9.0	May 2024	Publication
V17.10.0	August 2024	Publication
V17.11.0	January 2025	Publication
V17.12.0	October 2025	Publication