

# ETSI TS 138 141-2 V18.7.0 (2024-10)



**5G;  
NR;  
Base Station (BS) conformance testing  
Part 2: Radiated conformance testing  
(3GPP TS 38.141-2 version 18.7.0 Release 18)**



---

Reference

RTS/TSGR-0438141-2vi70

---

Keywords

5G

**ETSI**

650 Route des Lucioles  
F-06921 Sophia Antipolis Cedex - FRANCE

Tel.: +33 4 92 94 42 00 Fax: +33 4 93 65 47 16

Siret N° 348 623 562 00017 - APE 7112B  
Association à but non lucratif enregistrée à la  
Sous-Préfecture de Grasse (06) N° w061004871

---

**Important notice**

The present document can be downloaded from the  
ETSI [Search & Browse Standards application](#).

The present document may be made available in electronic versions and/or in print. The content of any electronic and/or print versions of the present document shall not be modified without the prior written authorization of ETSI. In case of any existing or perceived difference in contents between such versions and/or in print, the prevailing version of an ETSI deliverable is the one made publicly available in PDF format on [ETSI deliver](#).

Users should be aware that the present document may be revised or have its status changed,  
this information is available in the [Milestones listing](#).

If you find errors in the present document, please send your comments to  
the relevant service listed under [Committee Support Staff](#).

If you find a security vulnerability in the present document, please report it through our  
[Coordinated Vulnerability Disclosure \(CVD\)](#) program.

---

**Notice of disclaimer & limitation of liability**

The information provided in the present deliverable is directed solely to professionals who have the appropriate degree of experience to understand and interpret its content in accordance with generally accepted engineering or other professional standard and applicable regulations.

No recommendation as to products and services or vendors is made or should be implied.

No representation or warranty is made that this deliverable is technically accurate or sufficient or conforms to any law and/or governmental rule and/or regulation and further, no representation or warranty is made of merchantability or fitness for any particular purpose or against infringement of intellectual property rights.

In no event shall ETSI be held liable for loss of profits or any other incidental or consequential damages.

Any software contained in this deliverable is provided "AS IS" with no warranties, express or implied, including but not limited to, the warranties of merchantability, fitness for a particular purpose and non-infringement of intellectual property rights and ETSI shall not be held liable in any event for any damages whatsoever (including, without limitation, damages for loss of profits, business interruption, loss of information, or any other pecuniary loss) arising out of or related to the use of or inability to use the software.

---

**Copyright Notification**

No part may be reproduced or utilized in any form or by any means, electronic or mechanical, including photocopying and microfilm except as authorized by written permission of ETSI.

The content of the PDF version shall not be modified without the written authorization of ETSI.

The copyright and the foregoing restriction extend to reproduction in all media.

© ETSI 2024.  
All rights reserved.

---

# Intellectual Property Rights

## Essential patents

IPRs essential or potentially essential to normative deliverables may have been declared to ETSI. The declarations pertaining to these essential IPRs, if any, are publicly available for **ETSI members and non-members**, and can be found in ETSI SR 000 314: "*Intellectual Property Rights (IPRs); Essential, or potentially Essential, IPRs notified to ETSI in respect of ETSI standards*", which is available from the ETSI Secretariat. Latest updates are available on the ETSI Web server (<https://ipr.etsi.org/>).

Pursuant to the ETSI Directives including the ETSI IPR Policy, no investigation regarding the essentiality of IPRs, including IPR searches, has been carried out by ETSI. No guarantee can be given as to the existence of other IPRs not referenced in ETSI SR 000 314 (or the updates on the ETSI Web server) which are, or may be, or may become, essential to the present document.

## Trademarks

The present document may include trademarks and/or tradenames which are asserted and/or registered by their owners. ETSI claims no ownership of these except for any which are indicated as being the property of ETSI, and conveys no right to use or reproduce any trademark and/or tradename. Mention of those trademarks in the present document does not constitute an endorsement by ETSI of products, services or organizations associated with those trademarks.

**DECT™**, **PLUGTESTS™**, **UMTS™** and the ETSI logo are trademarks of ETSI registered for the benefit of its Members. **3GPP™** and **LTE™** are trademarks of ETSI registered for the benefit of its Members and of the 3GPP Organizational Partners. **oneM2M™** logo is a trademark of ETSI registered for the benefit of its Members and of the oneM2M Partners. **GSM®** and the GSM logo are trademarks registered and owned by the GSM Association.

---

# Legal Notice

This Technical Specification (TS) has been produced by ETSI 3rd Generation Partnership Project (3GPP).

The present document may refer to technical specifications or reports using their 3GPP identities. These shall be interpreted as being references to the corresponding ETSI deliverables.

The cross reference between 3GPP and ETSI identities can be found under <https://webapp.etsi.org/key/queryform.asp>.

---

# Modal verbs terminology

In the present document "**shall**", "**shall not**", "**should**", "**should not**", "**may**", "**need not**", "**will**", "**will not**", "**can**" and "**cannot**" are to be interpreted as described in clause 3.2 of the [ETSI Drafting Rules](#) (Verbal forms for the expression of provisions).

"**must**" and "**must not**" are **NOT** allowed in ETSI deliverables except when used in direct citation.

# Contents

Intellectual Property Rights .....	2
Legal Notice .....	2
Modal verbs terminology.....	2
Foreword.....	18
1 Scope .....	20
2 References .....	20
3 Definitions, symbols and abbreviations .....	22
3.1 Definitions .....	22
3.2 Symbols.....	25
3.3 Abbreviations .....	27
4 General radiated test conditions and declarations .....	29
4.1 Measurement uncertainties and test requirements .....	29
4.1.1 General.....	29
4.1.2 Acceptable uncertainty of OTA Test System .....	31
4.1.2.1 General .....	31
4.1.2.2 Measurement of transmitter .....	32
4.1.2.3 Measurement of receiver .....	34
4.1.2.4 Measurement of performance requirement .....	38
4.1.3 Interpretation of measurement results.....	39
4.2 Radiated requirement reference points .....	39
4.3 Base station classes .....	41
4.4 Regional requirements.....	41
4.5 BS configurations .....	42
4.5.1 Transmit configurations .....	42
4.5.2 Receive configurations .....	43
4.5.3 Power supply options.....	44
4.5.4 BS with integrated Iuant BS modem .....	45
4.6 Manufacturer's declarations.....	45
4.7 Test configurations .....	55
4.7.1 General.....	55
4.7.2 Test signal configurations.....	56
4.7.2.1 Test signal used to build Test Configurations .....	56
4.7.2.2 NRTC1: Contiguous spectrum operation .....	56
4.7.2.2.1 NRTC1 generation.....	56
4.7.2.2.2 NRTC1 power allocation.....	56
4.7.2.3 NRTC2: Contiguous CA occupied bandwidth .....	57
4.7.2.3.1 NRTC2 generation.....	57
4.7.2.3.2 NRTC2 power allocation.....	57
4.7.2.4 NRTC3: Non-contiguous spectrum operation.....	57
4.7.2.4.1 NRTC3 generation.....	58
4.7.2.4.2 NRTC3 power allocation.....	58
4.7.2.5 NRTC4: Multi-band test configuration for full carrier allocation .....	58
4.7.2.5.1 NRTC4 generation.....	58
4.7.2.5.2 NRTC4 power allocation.....	59
4.7.2.6 NRTC5: Multi-band test configuration with high PSD per carrier .....	59
4.7.2.6.1 NRTC5 generation.....	59
4.7.2.6.2 NRTC5 power allocation.....	59
4.8 Applicability of requirements.....	60
4.8.1 Requirement set applicability .....	60
4.8.2 Applicability of test configurations for <i>single-band RIB</i> .....	60
4.8.3 Applicability of test configurations for <i>multi-band RIB</i> .....	61
4.8.4 Additional conformance .....	62
4.9 RF channels and test models .....	63
4.9.1 RF channels .....	63

4.9.2	Test models .....	64
4.9.2.1	General .....	64
4.9.2.2	NR FR2 test models .....	64
4.9.2.2.1	NR FR2 test model 1.1 (NR-FR2-TM1.1).....	65
4.9.2.2.2	NR FR2 test model 2 (NR-FR2-TM2).....	66
4.9.2.2.2a	NR FR2 test model 2a (NR-FR2-TM2a).....	66
4.9.2.2.3	NR FR2 test model 3.1 (NR-FR2-TM3.1).....	67
4.9.2.2.4	NR FR2 test model 3.1a (NR-FR2-TM3.1a).....	67
4.9.2.3	Data content of physical channels and signals for NR-FR2-TM.....	67
4.9.2.3.1	PDCCH.....	68
4.9.2.3.2	PDSCH .....	68
4.10	Requirements for contiguous and non-contiguous spectrum.....	69
4.11	Requirements for BS capable of multi-band operation .....	69
4.12	Co-location requirements .....	70
4.12.1	General.....	70
4.12.2	Co-location test antenna.....	70
4.12.2.1	General .....	70
4.12.2.2	Co-location test antenna characteristics .....	70
4.12.2.3	Co-location test antenna alignment .....	71
4.13	Format and interpretation of tests .....	72
4.14	Reference coordinate system .....	73
5	Operating bands and channel arrangement.....	75
6	Radiated transmitter characteristics.....	76
6.1	General .....	76
6.2	Radiated transmit power.....	76
6.2.1	Definition and applicability .....	76
6.2.2	Minimum requirement .....	77
6.2.3	Test purpose.....	77
6.2.4	Method of test .....	77
6.2.4.1	Initial conditions .....	77
6.2.4.2	Procedure .....	77
6.2.5	Test requirement .....	78
6.3	OTA base station output power .....	78
6.3.1	Definition and applicability .....	78
6.3.2	Minimum requirement .....	79
6.3.3	Test purpose.....	79
6.3.4	Method of test .....	79
6.3.4.1	Initial conditions .....	79
6.3.4.2	Procedure .....	79
6.3.5	Test requirement .....	80
6.3.5.1	<i>BS type 1-O</i> .....	80
6.3.5.2	<i>BS type 2-O</i> .....	80
6.4	OTA output power dynamics .....	80
6.4.1	General.....	80
6.4.2	OTA RE power control dynamic range .....	80
6.4.2.1	Definition and applicability.....	80
6.4.2.2	Minimum requirement .....	81
6.4.2.3	Method of test .....	81
6.4.3	OTA total power dynamic range.....	81
6.4.3.1	Definition and applicability.....	81
6.4.3.2	Minimum requirement .....	81
6.4.3.3	Test purpose .....	81
6.4.3.4	Method of test .....	81
6.4.3.4.1	Initial conditions.....	81
6.4.3.4.2	Procedure.....	81
6.4.3.5	Test requirement .....	82
6.4.3.5.1	<i>BS type 1-O</i> .....	82
6.4.3.5.2	<i>BS type 2-O</i> .....	83
6.5	OTA transmit ON/OFF power.....	83
6.5.1	OTA transmitter OFF power.....	83

6.5.1.1	Definition and applicability.....	83
6.5.1.2	Minimum requirement .....	84
6.5.1.3	Test purpose .....	84
6.5.1.4	Method of test .....	84
6.5.1.5	Test requirements.....	84
6.5.2	OTA transmitter transient period.....	84
6.5.2.1	Definition and applicability.....	84
6.5.2.2	Minimum requirement .....	85
6.5.2.3	Test purpose .....	85
6.5.2.4	Method of test .....	85
6.5.2.4.1	Initial conditions.....	85
6.5.2.4.2	Procedure.....	86
6.5.2.5	Test requirements.....	87
6.5.2.5.1	BS type 1-O.....	87
6.5.2.5.2	BS type 2-O.....	87
6.6	OTA transmitted signal quality .....	87
6.6.1	General.....	87
6.6.2	OTA frequency error .....	87
6.6.2.1	Definition and applicability.....	87
6.6.2.2	Minimum Requirement .....	87
6.6.2.3	Test purpose .....	88
6.6.2.4	Method of test .....	88
6.6.2.4.1	Initial conditions.....	88
6.6.2.5	Test Requirements.....	88
6.6.3	OTA modulation quality .....	88
6.6.3.1	Definition and applicability.....	88
6.6.3.2	Minimum Requirement .....	88
6.6.3.3	Test purpose .....	88
6.6.3.4	Method of test .....	88
6.6.3.4.1	Initial conditions.....	88
6.6.3.4.2	Procedure.....	89
6.6.3.5	Test requirements.....	90
6.6.3.5.1	BS type 1-O.....	90
6.6.3.5.2	BS type 2-O.....	92
6.6.4	OTA time alignment error .....	94
6.6.4.1	Definition and applicability.....	94
6.6.4.2	Minimum requirement .....	94
6.6.4.3	Test purpose .....	94
6.6.4.4	Method of test .....	94
6.6.4.4.1	Initial conditions.....	94
6.6.4.4.2	Procedure.....	94
6.6.4.5	Test Requirement .....	95
6.6.4.5.1	BS type 1-O.....	95
6.6.4.5.2	BS type 2-O.....	95
6.7	OTA unwanted emissions .....	96
6.7.1	General.....	96
6.7.2	OTA occupied bandwidth.....	96
6.7.2.1	Definition and applicability.....	96
6.7.2.2	Minimum requirement .....	97
6.7.2.3	Test purpose .....	97
6.7.2.4	Method of test .....	97
6.7.2.4.1	Initial conditions.....	97
6.7.2.4.2	Procedure.....	97
6.7.2.5	Test requirement .....	99
6.7.2.5.1	BS type 1-O.....	99
6.7.2.5.2	BS type 2-O.....	99
6.7.3	OTA Adjacent Channel Leakage Power Ratio (ACLR).....	99
6.7.3.1	Definition and applicability.....	99
6.7.3.2	Minimum requirement .....	99
6.7.3.3	Test purpose .....	99
6.7.3.4	Method of test .....	99
6.7.3.4.1	Initial conditions.....	99

6.7.3.4.2	Procedure .....	100
6.7.3.5	Test requirements .....	101
6.7.3.5.1	<i>BS type 1-O</i> .....	101
6.7.3.5.2	<i>BS type 2-O</i> .....	103
6.7.4	OTA operating band unwanted emissions .....	106
6.7.4.1	Definition and applicability .....	106
6.7.4.2	Minimum requirement .....	106
6.7.4.3	Test purpose .....	106
6.7.4.4	Method of test .....	106
6.7.4.4.1	Initial conditions .....	106
6.7.4.4.2	Procedure .....	107
6.7.4.5	Test requirements .....	107
6.7.4.5.1	<i>BS type 1-O</i> .....	107
6.7.4.5.2	<i>BS type 2-O</i> .....	121
6.7.5	OTA transmitter spurious emissions .....	124
6.7.5.1	General .....	124
6.7.5.2	General OTA transmitter spurious emissions requirements .....	125
6.7.5.2.1	Definition and applicability .....	125
6.7.5.2.2	Minimum requirement .....	125
6.7.5.2.3	Test purpose .....	125
6.7.5.2.4	Method of test .....	125
6.7.5.2.5	Test requirement .....	126
6.7.5.3	Protection of the BS receiver of own or different BS .....	128
6.7.5.3.1	Definition and applicability .....	128
6.7.5.3.2	Minimum requirements .....	128
6.7.5.3.3	Test purpose .....	129
6.7.5.3.4	Method of test .....	129
6.7.5.3.5	Test requirements .....	130
6.7.5.4	Additional spurious emissions requirements .....	130
6.7.5.4.1	Definition and applicability .....	130
6.7.5.4.2	Minimum Requirement .....	130
6.7.5.4.3	Test purpose .....	131
6.7.5.4.4	Method of test .....	131
6.7.5.4.5	Test requirement .....	132
6.7.5.5	Co-location requirements .....	142
6.7.5.5.1	Definition and applicability .....	142
6.7.5.5.2	Minimum requirements .....	143
6.7.5.5.3	Test purpose .....	143
6.7.5.5.4	Method of test .....	143
6.7.5.5.5	Test requirements .....	144
6.8	OTA transmitter intermodulation .....	149
6.8.1	Definition and applicability .....	149
6.8.2	Minimum requirement .....	149
6.8.3	Test purpose .....	149
6.8.4	Method of test .....	150
6.8.4.1	Initial conditions .....	150
6.8.4.2	Procedure .....	150
6.8.5	Test requirements .....	151
6.8.5.1	Requirement for BS type 1-O .....	151
6.8.5.2	Additional requirements (regional) .....	152
7	Radiated receiver characteristics .....	153
7.1	General .....	153
7.2	OTA sensitivity .....	154
7.2.1	Definition and applicability .....	154
7.2.2	Minimum requirement .....	154
7.2.3	Test Purpose .....	154
7.2.4	Method of test .....	154
7.2.4.1	Initial conditions .....	154
7.2.4.2	Procedure .....	155
7.2.5	Test requirements .....	155
7.2.5.1	General .....	155

7.2.5.2	Test requirements for <i>BS type 1-H</i> and <i>BS type 1-O</i> .....	155
7.2.5.3	Test requirements for <i>BS type 2-O</i> .....	156
7.3	OTA reference sensitivity level .....	157
7.3.1	Definition and applicability .....	157
7.3.2	Minimum requirement .....	157
7.3.3	Test Purpose.....	157
7.3.4	Method of test .....	157
7.3.4.1	Initial conditions .....	157
7.3.4.2	Procedure .....	157
7.3.5	Test requirements.....	158
7.3.5.1	General .....	158
7.3.5.2	Test requirements for <i>BS type 1-O</i> .....	158
7.3.5.3	Test requirements for <i>BS type 2-O</i> .....	159
7.4	OTA dynamic range .....	161
7.4.1	Definition and applicability .....	161
7.4.2	Minimum requirement .....	161
7.4.3	Test purpose.....	161
7.4.4	Method of test .....	161
7.4.4.1	Initial conditions .....	161
7.4.4.2	Procedure .....	161
7.4.5	Test requirement .....	162
7.4.5.1	General .....	162
7.4.5.2	Test requirements for <i>BS type 1-O</i> .....	162
7.5	OTA in-band selectivity and blocking.....	175
7.5.1	OTA adjacent channel selectivity .....	175
7.5.1.1	Definition and applicability.....	175
7.5.1.2	Minimum requirement .....	175
7.5.1.3	Test purpose .....	175
7.5.1.4	Method of test .....	175
7.5.1.4.1	Initial conditions .....	175
7.5.1.4.2	Procedure.....	175
7.5.1.5	Test requirement .....	176
7.5.1.5.1	General .....	176
7.5.1.5.2	Test requirements for <i>BS type 1-O</i> .....	176
7.5.1.5.3	Test requirements for <i>BS type 2-O</i> .....	177
7.5.2	OTA in-band blocking.....	178
7.5.2.1	Definition and applicability.....	178
7.5.2.2	Minimum requirement .....	178
7.5.2.3	Test purpose .....	178
7.5.2.4	Method of test .....	178
7.5.2.4.1	Initial conditions .....	178
7.5.2.4.2	Procedure.....	179
7.5.2.5	Test requirement .....	180
7.5.2.5.1	General .....	180
7.5.2.5.2	Test requirements for <i>BS type 1-O</i> .....	180
7.5.2.5.3	Test requirements for <i>BS type 2-O</i> .....	183
7.6	OTA out-of-band blocking .....	184
7.6.1	Definition and applicability .....	184
7.6.2	Minimum requirement .....	184
7.6.3	Test purpose.....	184
7.6.4	Method of test .....	185
7.6.4.1	Initial conditions .....	185
7.6.4.2	Procedure .....	185
7.6.4.2.1	<i>BS type 1-O</i> procedure for out-of-band blocking.....	185
7.6.4.2.2	<i>BS type 1-O</i> procedure for co-location blocking .....	186
7.6.4.2.3	<i>BS type 2-O</i> procedure for out-of-band blocking.....	186
7.6.5	Test requirements.....	187
7.6.5.1	Requirement for <i>BS type 1-O</i> .....	187
7.6.5.1.1	General .....	187
7.6.5.1.2	Co-location requirement .....	188
7.6.5.2	Requirement for <i>BS type 2-O</i> .....	188
7.6.5.2.1	General requirement .....	188



7.7	OTA receiver spurious emissions.....	189
7.7.1	Definition and applicability .....	189
7.7.2	Minimum requirement .....	189
7.7.3	Test purpose.....	190
7.7.4	Method of test .....	190
7.7.4.1	Initial conditions .....	190
7.7.4.2	Procedure .....	190
7.7.5	Test requirement .....	191
7.7.5.1	Test requirement for <i>BS type 1-O</i> .....	191
7.7.5.2	Test requirement for <i>BS type 2-O</i> .....	192
7.8	OTA receiver intermodulation .....	193
7.8.1	Definition and applicability .....	193
7.8.2	Minimum requirement .....	193
7.8.3	Test purpose.....	193
7.8.4	Method of test .....	193
7.8.4.1	Initial conditions .....	193
7.8.4.2	Procedure .....	194
7.8.5	Test requirement .....	194
7.8.5.1	<i>BS type 1-O</i> .....	194
7.8.5.2	<i>BS type 2-O</i> .....	200
7.9	OTA in-channel selectivity.....	201
7.9.1	Definition and applicability .....	201
7.9.2	Minimum requirement .....	201
7.9.3	Test purpose.....	202
7.9.4	Method of test .....	202
7.9.4.1	Initial conditions .....	202
7.9.4.2	Procedure .....	202
7.9.5	Test requirement .....	203
7.9.5.1	<i>BS type 1-O</i> .....	203
7.9.5.2	<i>BS type 2-O</i> .....	208
8	Radiated performance requirements.....	210
8.1	General .....	210
8.1.0	Scope and definitions.....	210
8.1.1	OTA demodulation branches .....	210
8.1.2	Applicability rule .....	211
8.1.2.0	General .....	211
8.1.2.1	Applicability of PUSCH performance requirements.....	211
8.1.2.1.1	Applicability of requirements for different subcarrier spacings .....	211
8.1.2.1.2	Applicability of requirements for different channel bandwidths .....	211
8.1.2.1.3	Applicability of requirements for different configurations.....	211
8.1.2.1.4	Applicability of requirements for uplink carrier aggregation .....	211
8.1.2.1.5	Applicability of requirements for TDD with different UL-DL patterns .....	211
8.1.2.1.6	Applicability of UL timing adjustment requirements for different scenarios .....	212
8.1.2.1.7	Applicability of 2-step RA type requirements for different subcarrier spacings .....	212
8.1.2.1.8	Applicability of PUSCH with 0.001% BLER requirements.....	212
8.1.2.1.9	Applicability of PUSCH repetition type A requirements .....	212
8.1.2.1.10	Applicability of requirements with 256QAM.....	212
8.1.2.1.11	Applicability of PUSCH with enhanced DM-RS requirements.....	212
8.1.2.2	Applicability of PUCCH performance requirements .....	212
8.1.2.2.1	Applicability of requirements for different formats.....	212
8.1.2.2.2	Applicability of requirements for different subcarrier spacings .....	212
8.1.2.2.3	Applicability of requirements for different channel bandwidths .....	212
8.1.2.2.4	Applicability of requirements for different configurations.....	213
8.1.2.2.5	Applicability of requirements for multi-slot PUCCH.....	213
8.1.2.2.6	Applicability of requirements for PUCCH sub-slot based repetition .....	213
8.1.2.3	Applicability of PRACH performance requirements .....	213
8.1.2.3.1	Applicability of requirements for different formats.....	213
8.1.2.3.2	Applicability of requirements for different subcarrier spacings .....	213
8.1.2.3.3	Applicability of requirements for different channel bandwidths .....	213
8.1.2.3.4	Applicability of requirements for different restricted set types of long PRACH format 0 .....	213
8.1.2.4	Applicability of PUSCH for high speed train performance requirements.....	214

8.1.2.4.1	Applicability of requirements for different speeds .....	214
8.1.2.4.2	Applicability of requirements for 1T1R .....	214
8.1.2.4.3	Applicability of requirements for different channel bandwidths .....	214
8.1.2.4.4	Applicability of requirements for different DM-RS configurations .....	214
8.1.2.5	Applicability of interlaced PUSCH performance requirements .....	214
8.1.2.5.1	General applicability of interlaced PUSCH performance requirements .....	214
8.1.2.5.2	Applicability of requirements for different subcarrier spacings .....	214
8.1.2.5.3	Applicability of requirements for different channel bandwidths .....	215
8.1.2.5.4	Applicability of requirements for different configurations .....	215
8.1.2.5.5	Applicability of CG-UCI multiplexed on PUSCH requirements .....	215
8.1.2.6	Applicability of interlaced PUCCH performance requirements .....	215
8.1.2.6.1	General applicability of interlaced PUCCH performance requirements .....	215
8.1.2.6.2	Applicability of requirements for different formats .....	215
8.1.2.6.3	Applicability of requirements for different subcarrier spacings .....	215
8.1.2.6.4	Applicability of requirements for different channel bandwidths .....	215
8.1.2.7	Applicability of performance requirements for PRACH with $L_{RA}=1151$ and $L_{RA}=571$ .....	215
8.1.2.7.1	Applicability of requirements for different formats .....	215
8.1.2.7.2	Applicability of requirements for different subcarrier spacings .....	216
8.1.2.7.3	Applicability of requirements for different channel bandwidths .....	216
8.1.2.8	Applicability of performance requirements for PUSCH with TB over Multi-Slots .....	216
8.1.2.8.1	Applicability of requirements for different UL-DL patterns .....	216
8.1.2.9	Applicability of performance requirements for PUSCH with DM-RS bundling .....	216
8.1.2.9.1	Applicability of requirements for TDD different subcarrier spacings .....	216
8.1.2.9.2	Applicability of requirements for TDD with different UL-DL patterns .....	216
8.1.2.9.3	Applicability of requirements for different receiver antenna connectors .....	216
8.1.2.10	Applicability of performance requirements for PUCCH with DM-RS bundling .....	216
8.1.2.10.1	Applicability of requirements for TDD different subcarrier spacings .....	216
8.1.2.10.2	Applicability of requirements for TDD with different UL-DL patterns .....	216
8.1.2.11	Applicability of ATG PUSCH performance requirements .....	217
8.1.2.11.1	Applicability of requirements for TDD with different UL-DL patterns .....	217
8.1.2.11.2	Applicability of requirements for different MCSs .....	217
8.1.2.12	Applicability of ATG PUCCH performance requirements .....	217
8.1.2.13	Applicability of ATG PRACH performance requirements .....	217
8.1.2.14	Applicability of performance requirements for Multiple PRACH transmission .....	217
8.1.2.14.1	Applicability of requirements for different formats .....	217
8.1.2.14.2	Applicability of requirements for different channel bandwidths .....	217
8.2	OTA performance requirements for PUSCH .....	217
8.2.1	Performance requirements for PUSCH with transform precoding disabled .....	217
8.2.1.1	Definition and applicability .....	217
8.2.1.2	Minimum Requirement .....	218
8.2.1.3	Test purpose .....	218
8.2.1.4	Method of test .....	218
8.2.1.4.1	Initial conditions .....	218
8.2.1.4.2	Procedure .....	218
8.2.1.5	Test Requirement .....	220
8.2.1.5.1	Test requirement for <i>BS type 1-O</i> .....	220
8.2.1.5.2	Test requirement for <i>BS type 2-O</i> .....	225
8.2.2	Performance requirements for PUSCH with transform precoding enabled .....	229
8.2.2.1	Definition and applicability .....	229
8.2.2.2	Minimum Requirement .....	229
8.2.2.3	Test Purpose .....	229
8.2.2.4	Method of test .....	229
8.2.2.4.1	Initial Conditions .....	229
8.2.2.4.2	Procedure .....	229
8.2.2.5	Test Requirement .....	231
8.2.2.5.1	Test requirement for <i>BS type 1-O</i> .....	231
8.2.2.5.2	Test requirement for <i>BS type 2-O</i> .....	232
8.2.3	Performance requirements for UCI multiplexed on PUSCH .....	233
8.2.3.1	Definition and applicability .....	233
8.2.3.2	Minimum Requirement .....	233
8.2.3.3	Test purpose .....	234
8.2.3.4	Method of test .....	234

8.2.3.4.1	Initial conditions .....	234
8.2.3.4.2	Procedure .....	234
8.2.3.5	Test Requirement .....	236
8.2.3.5.1	Test requirement for <i>BS type 1-O</i> .....	236
8.2.3.5.2	Test requirement for <i>BS type 2-O</i> .....	237
8.2.4	Performance requirements for PUSCH for high speed train .....	238
8.2.4.1	Definition and applicability .....	238
8.2.4.2	Minimum Requirement .....	238
8.2.4.3	Test Purpose .....	238
8.2.4.4	Method of test .....	238
8.2.4.4.1	Initial Conditions .....	238
8.2.4.4.2	Procedure .....	239
8.2.4.5	Test Requirement for <i>BS Type 1-O</i> .....	241
8.2.4.6	Test Requirement for <i>BS Type 2-O</i> .....	243
8.2.5	Performance requirements for UL timing adjustment .....	243
8.2.5.1	Definition and applicability .....	243
8.2.5.2	Minimum Requirement .....	244
8.2.5.3	Test Purpose .....	244
8.2.5.4	Method of test .....	244
8.2.5.4.1	Initial Conditions .....	244
8.2.5.4.2	Procedure .....	244
8.2.5.5	Test Requirement for High Speed Train for <i>BS type 1-O</i> .....	247
8.2.5.5a	Test Requirement for High Speed Train for <i>BS type 2-O</i> .....	248
8.2.5.6	Test Requirement for Normal Mode .....	248
8.2.6	Performance requirements for PUSCH with 0.001% BLER .....	248
8.2.6.1	Definition and applicability .....	248
8.2.6.2	Minimum Requirement .....	249
8.2.6.3	Test Purpose .....	249
8.2.6.4	Method of test .....	249
8.2.6.4.1	Initial Conditions .....	249
8.2.6.4.2	Procedure .....	249
8.2.6.5	Test requirement .....	250
8.2.6.5.1	Test requirement for <i>BS type 1-O</i> .....	250
8.2.7	Performance requirements for PUSCH repetition Type A .....	252
8.2.7.1	Definition and applicability .....	252
8.2.7.2	Minimum Requirement .....	252
8.2.7.3	Test purpose .....	252
8.2.7.4	Method of test .....	252
8.2.7.4.1	Initial conditions .....	252
8.2.7.4.2	Procedure .....	252
8.2.7.5	Test Requirement .....	254
8.2.7.5.1	Test requirement for <i>BS type 1-O</i> .....	254
8.2.7.5.2	Test requirement for <i>BS type 2-O</i> .....	256
8.2.8.1	Definition and applicability .....	256
8.2.8.2	Minimum Requirement .....	257
8.2.8.3	Test purpose .....	257
8.2.8.4	Method of test .....	257
8.2.8.4.1	Initial conditions .....	257
8.2.8.4.2	Procedure .....	257
8.2.8.5	Test Requirement .....	259
8.2.8.5.1	Test requirement for <i>BS type 1-O</i> .....	259
8.2.8.5.2	Test requirement for <i>BS type 2-O</i> .....	260
8.2.9	Performance requirements for MsgA PUSCH .....	261
8.2.9.1	Definition and applicability .....	261
8.2.9.2	Minimum Requirement .....	261
8.2.9.3	Test Purpose .....	261
8.2.9.4	Method of test .....	261
8.2.9.4.1	Initial Conditions .....	261
8.2.9.4.2	Procedure .....	261
8.2.9.5	Test Requirement .....	264
8.2.9.5.1	Test Requirement for <i>BS type 1-O</i> .....	264
8.2.9.5.2	Test Requirement for <i>BS type 2-O</i> .....	265

8.2.10	Requirements for interlaced PUSCH .....	266
8.2.10.1	Definition and applicability.....	266
8.2.10.2	Minimum Requirement .....	266
8.2.10.3	Test Purpose .....	266
8.2.10.4	Method of test .....	266
8.2.10.4.1	Initial Conditions .....	266
8.2.10.4.2	Procedure.....	267
8.2.10.5	Test Requirement .....	268
8.2.10.5.1	Test requirement for <i>BS type 1-O</i> .....	268
8.2.11	Performance requirements for CG-UCI multiplexed on interlaced PUSCH.....	269
8.2.11.1	Definition and applicability.....	269
8.2.11.2	Minimum Requirement .....	269
8.2.11.3	Test purpose .....	269
8.2.11.4	Method of test .....	269
8.2.11.4.1	Initial conditions .....	269
8.2.11.4.2	Procedure.....	269
8.2.11.5	Test Requirement .....	271
8.2.11.5.1	Test requirement for <i>BS type 1-O</i> .....	271
8.2.12	Performance requirements for TB processing over multi-slot PUSCH (TBoMS).....	271
8.2.12.1	Definition and applicability.....	271
8.2.12.2	Minimum Requirement .....	271
8.2.12.3	Test Purpose .....	272
8.2.12.4	Method of test .....	272
8.2.12.4.1	Initial Conditions .....	272
8.2.12.4.2	Procedure.....	272
8.2.12.5	Test Requirement .....	274
8.2.12.5.1	Test requirement for <i>BS type 1-O</i> .....	274
8.2.12.5.2	Test requirement for <i>BS type 2-O</i> .....	275
8.2.13	Performance requirements for PUSCH with DMRS bundling .....	275
8.2.13.1	Definition and applicability.....	275
8.2.13.2	Minimum Requirement .....	276
8.2.13.3	Test Purpose .....	276
8.2.13.4	Method of test .....	276
8.2.13.4.1	Initial Conditions .....	276
8.2.13.4.2	Procedure.....	276
8.2.13.5	Test Requirement .....	278
8.2.13.5.1	Test requirement for <i>BS type 1-O</i> .....	278
8.2.13.5.2	Test requirement for <i>BS type 2-O</i> .....	280
8.2.14	Performance requirements for PUSCH for ATG.....	281
8.2.14.1	Definition and applicability.....	281
8.2.14.2	Minimum Requirement .....	281
8.2.14.3	Test Purpose .....	281
8.2.14.4	Method of test .....	281
8.2.14.4.1	Initial conditions .....	281
8.2.14.4.2	Procedure.....	281
8.2.14.5	Test requirement .....	282
8.2.14.5.1	Test requirement for <i>BS type 1-O</i> .....	282
8.2.15	Performance requirements for PUSCH with enhanced DM-RS .....	283
8.2.15.1	Definition and applicability.....	283
8.2.15.2	Minimum Requirement .....	283
8.2.15.3	Test purpose .....	283
8.2.15.4	Method of test .....	283
8.2.15.4.1	Initial conditions .....	283
8.2.15.4.2	Procedure.....	284
8.2.15.5	Test Requirement .....	285
8.2.15.5.1	Test requirement for <i>BS type 1-O</i> .....	285
8.3	OTA performance requirements for PUCCH .....	286
8.3.1	Performance requirements for PUCCH format 0.....	286
8.3.1.1	Definition and applicability.....	286
8.3.1.2	Minimum Requirement .....	286
8.3.1.3	Test purpose .....	286
8.3.1.4	Method of test .....	286

8.3.1.4.1	Initial conditions .....	286
8.3.1.4.2	Procedure .....	287
8.3.1.5	Test Requirement .....	288
8.3.1.5.1	Test requirement for <i>BS type 1-O</i> .....	288
8.3.1.5.2	Test requirement for <i>BS type 2-O</i> .....	289
8.3.2	Performance requirements for PUCCH format 1 .....	289
8.3.2.1	NACK to ACK detection .....	289
8.3.2.1.1	Definition and applicability .....	289
8.3.2.1.2	Minimum Requirement .....	290
8.3.2.1.3	Test purpose .....	290
8.3.2.1.4	Method of test .....	290
8.3.2.1.5	Test Requirement .....	292
8.3.2.2	ACK missed detection .....	293
8.3.2.2.1	Definition and applicability .....	293
8.3.2.2.2	Minimum Requirement .....	294
8.3.2.2.3	Test purpose .....	294
8.3.2.2.4	Method of test .....	294
8.3.2.2.5	Test Requirement .....	296
8.3.3	Performance requirements for PUCCH format 2 .....	297
8.3.3.1	ACK missed detection performance requirements .....	297
8.3.3.1.1	Definition and applicability .....	297
8.3.3.1.2	Minimum Requirement .....	297
8.3.3.1.3	Test Purpose .....	297
8.3.3.1.4	Method of test .....	297
8.3.3.1.5	Test requirement .....	299
8.3.3.2	UCI BLER performance requirements .....	300
8.3.3.2.1	Definition and applicability .....	300
8.3.3.2.2	Minimum Requirement .....	301
8.3.3.2.3	Test Purpose .....	301
8.3.3.2.4	Method of test .....	301
8.3.3.2.5	Test requirement .....	302
8.3.4	Performance requirements for PUCCH format 3 .....	303
8.3.4.1	Definition and applicability .....	303
8.3.4.2	Minimum requirement .....	304
8.3.4.3	Test purpose .....	304
8.3.4.4	Method of test .....	304
8.3.4.4.1	Initial conditions .....	304
8.3.4.4.2	Procedure .....	304
8.3.4.5	Test requirement .....	305
8.3.4.5.1	Test requirement for <i>BS type 1-O</i> .....	305
8.3.4.5.2	Test requirement for <i>BS type 2-O</i> .....	306
8.3.5	Performance requirements for PUCCH format 4 .....	307
8.3.5.1	Definition and applicability .....	307
8.3.5.2	Minimum requirement .....	307
8.3.5.3	Test purpose .....	307
8.3.5.4	Method of test .....	307
8.3.5.4.1	Initial conditions .....	307
8.3.5.4.2	Procedure .....	307
8.3.5.5	Test requirement .....	309
8.3.5.5.1	Test requirement for <i>BS type 1-O</i> .....	309
8.3.5.5.2	Test requirement for <i>BS type 2-O</i> .....	309
8.3.6	Performance requirements for multi-slot PUCCH format .....	310
8.3.6.1	Performance requirements for multi-slot PUCCH format 1 .....	310
8.3.6.1.1	NACK to ACK detection .....	310
8.3.6.1.2	ACK missed detection .....	312
8.3.7	Performance requirements for interlaced PUCCH format 0 .....	314
8.3.7.1	Definition and applicability .....	314
8.3.7.2	Minimum Requirement .....	315
8.3.7.3	Test purpose .....	315
8.3.7.4	Method of test .....	315
8.3.7.4.1	Initial conditions .....	315
8.3.7.4.2	Procedure .....	315

8.3.7.5	Test Requirement .....	316
8.3.7.5.1	Test requirement for <i>BS type 1-O</i> .....	316
8.3.8	Performance requirements for interlaced PUCCH format 1 .....	316
8.3.8.1	NACK to ACK detection .....	316
8.3.8.1.1	Definition and applicability .....	316
8.3.8.1.2	Minimum Requirement .....	317
8.3.8.1.3	Test purpose .....	317
8.3.8.1.4	Method of test.....	317
8.3.8.1.5	Test Requirement.....	318
8.3.8.2	ACK missed detection.....	318
8.3.8.2.1	Definition and applicability .....	318
8.3.8.2.2	Minimum Requirement .....	319
8.3.8.2.3	Test purpose .....	319
8.3.8.2.4	Method of test.....	319
8.3.8.2.5	Test Requirement.....	320
8.3.9	Performance requirements for interlaced PUCCH format 2 .....	321
8.3.9.1	Definition and applicability.....	321
8.3.9.2	Minimum Requirement .....	321
8.3.9.3	Test Purpose .....	321
8.3.9.4	Method of test .....	321
8.3.9.4.1	Initial conditions .....	321
8.3.9.4.2	Procedure.....	321
8.3.9.5	Test requirement .....	322
8.3.10	Performance requirements for interlaced PUCCH format 3 .....	323
8.3.10.1	Definition and applicability.....	323
8.3.10.2	Minimum Requirement .....	323
8.3.10.3	Test Purpose .....	323
8.3.10.4	Method of test .....	323
8.3.10.4.1	Initial conditions .....	323
8.3.10.4.2	Procedure.....	323
8.3.10.5	Test requirement .....	324
8.3.11	Performance requirements for PUCCH sub-slot based repetition format 0 .....	325
8.3.11.1	Definition and applicability.....	325
8.3.11.2	Minimum Requirement .....	325
8.3.11.3	Test purpose .....	325
8.3.11.4	Method of test .....	326
8.3.11.4.1	Initial conditions .....	326
8.3.11.4.2	Procedure.....	326
8.3.11.5	Test Requirement .....	327
8.3.11.5.1	Test requirement for <i>BS type 1-O</i> .....	327
8.3.12	Performance requirements PUCCH format 1 with DM-RS bundling.....	327
8.3.12.1	NACK to ACK detection .....	327
8.3.12.1.1	Definition and applicability .....	327
8.3.12.1.2	Minimum Requirement .....	328
8.3.12.1.3	Test purpose .....	328
8.3.12.1.4	Method of test.....	328
8.3.12.1.4.1	Initial conditions .....	328
8.3.12.1.4.2	Procedure .....	328
8.3.12.1.5	Test Requirement.....	329
8.3.12.1.5.1	Test Requirement for <i>BS type 1-O</i> .....	329
8.3.12.1.5.2	Test Requirement for <i>BS type 2-O</i> .....	330
8.3.12.2	ACK missed detection.....	330
8.3.12.2.1	Definition and applicability .....	330
8.3.12.2.2	Minimum Requirement .....	331
8.3.12.2.3	Test purpose .....	331
8.3.12.2.4	Method of test.....	331
8.3.12.2.4.1	Initial conditions .....	331
8.3.12.2.4.2	Procedure .....	331
8.3.12.2.5	Test Requirement.....	333
8.3.12.2.5.1	Test Requirement for <i>BS type 1-O</i> .....	333
8.3.12.2.5.2	Test Requirement for <i>BS type 2-O</i> .....	333
8.3.13	Performance requirements for PUCCH format 3 with DM-RS bundling .....	334

8.3.13.1	Definition and applicability.....	334
8.3.13.2	Minimum requirement .....	334
8.3.13.3	Test purpose .....	334
8.3.13.4	Method of test .....	334
8.3.13.4.1	Initial conditions.....	334
8.3.13.4.2	Procedure.....	334
8.3.13.5	Test requirement .....	336
8.3.13.5.1	Test Requirement for BS type 1-O .....	336
8.3.13.5.2	Test Requirement for BS type 2-O .....	336
8.4	OTA performance requirements for PRACH .....	337
8.4.1	PRACH false alarm probability and missed detection.....	337
8.4.1.1	Definition and applicability.....	337
8.4.1.2	Minimum requirement .....	337
8.4.1.3	Test purpose .....	337
8.4.1.4	Method of test .....	338
8.4.1.4.1	Initial conditions.....	338
8.4.1.4.2	Procedure.....	338
8.4.1.5	Test requirement for Normal Mode.....	341
8.4.1.5.1	Test requirement for BS type 1-O .....	341
8.4.1.5.2	Test requirement for BS type 2-O .....	342
8.4.1.6	Test requirement for high speed train.....	342
8.4.1.6.1	Test requirement for BS type 1-O .....	342
8.4.1.6.2	Test requirement for BS type 2-O .....	343
8.4.1.7	Test requirement for PRACH with $L_{RA}=1151$ and $L_{RA}=571$ .....	343
8.4.1.7.1	Test requirement for BS type 1-O .....	343
8.4.1.7.2	Test requirement for BS type 2-O .....	344
8.4.1.8	Test requirement for PRACH with repetition transmission .....	345
8.4.1.8.1	Test requirement for BS type 2-O .....	345
<b>Annex A (normative): Reference measurement channels .....</b>		<b>346</b>
A.1	Fixed Reference Channels for OTA sensitivity, OTA reference sensitivity level, OTA ACS, OTA in-band blocking, OTA out-of-band blocking, OTA receiver intermodulation and OTA in-channel selectivity (QPSK, R=1/3).....	346
A.2	Fixed Reference Channels for OTA dynamic range (16QAM, R=2/3) .....	348
A.3	Fixed Reference Channels for performance requirements (QPSK, R=193/1024) .....	348
A.3A	Fixed Reference Channels for performance requirements (QPSK, R=99/1024) .....	356
A.3B	Fixed Reference Channels for performance requirements (QPSK, R=308/1024) .....	358
A.4	Fixed Reference Channels for performance requirements (16QAM, R=658/1024) .....	362
A.5	Fixed Reference Channels for performance requirements (64QAM, R=567/1024) .....	367
A.6	PRACH Test preambles .....	370
A.7	Fixed Reference Channels for performance requirements (16QAM, R=434/1024) .....	371
A.8	Fixed Reference Channels for performance requirements (QPSK, R=157/1024) .....	373
A.9	Fixed Reference Channels for performance requirements (256QAM, R=682.5/1024) .....	374
A.10	Fixed Reference Channels for performance requirements (64QAM, R=517/1024) .....	376
A.11	Fixed Reference Channels for performance requirements (64QAM, R=438/1024) .....	380
A.12	Void.....	380
A.13	Fixed Reference Channels for performance requirements (64QAM, R=948/1024) .....	380
A.14	Fixed Reference Channels for performance requirements (256QAM, R=754/1024) .....	380
<b>Annex B (normative): Environmental requirements for the BS equipment .....</b>		<b>382</b>
B.1	General .....	382

B.2	Normal test environment .....	382
B.3	Extreme test environment.....	382
B.3.1	Extreme temperature .....	382
B.4	Vibration.....	383
B.5	Power supply .....	383
B.6	Measurement of test environments.....	383
B.7	OTA extreme test methods.....	384
B.7.1	Direct far field method .....	384
B.7.2	Relative method.....	384
<b>Annex C (informative): Test tolerances and derivation of test requirements.....</b>		<b>386</b>
C.1	Measurement of transmitter.....	387
C.2	Measurement of receiver .....	393
C.3	Measurement of performance requirements .....	395
<b>Annex D (normative): Calibration.....</b>		<b>398</b>
<b>Annex E (informative): OTA measurement system set-up.....</b>		<b>399</b>
E.1	Transmitter .....	399
E.1.1	Radiated transmit power, OTA output power dynamics, OTA transmitted signal quality, OTA occupied bandwidth, and OTA transmit ON/OFF power ( <i>BS type 2-O</i> ) .....	399
E.1.2	OTA base station output power, OTA ACLR, OTA operating band unwanted emissions .....	400
E.1.3	OTA spurious emissions .....	400
E.1.4	OTA co-location emissions, OTA transmit ON/OFF power ( <i>BS type 1-O</i> ) .....	401
E.1.5	OTA transmitter intermodulation .....	402
E.2	Receiver.....	403
E.2.1	OTA sensitivity and OTA reference sensitivity level.....	403
E.2.2	OTA dynamic range .....	403
E.2.3	OTA adjacent channel selectivity, general OTA blocking, and OTA narrowband blocking .....	404
E.2.4	OTA blocking.....	405
E.2.4.1	General OTA out-of-band blocking.....	405
E.2.4.2	OTA co-location blocking .....	405
E.2.5	OTA receiver spurious emissions.....	406
E.2.6	OTA receiver intermodulation .....	406
E.2.7	OTA in-channel selectivity.....	407
E.3	Performance requirements.....	407
<b>Annex F (normative): Void.....</b>		<b>409</b>
<b>Annex G (informative): Transmitter spatial emissions declaration.....</b>		<b>410</b>
G.1	General .....	410
G.2	Declarations.....	411
<b>Annex H (normative): Characteristics of the interfering signals.....</b>		<b>412</b>
<b>Annex I (normative): TRP measurement procedures .....</b>		<b>413</b>
I.1	General .....	413
I.2	Spherical equal angle grid .....	413
I.2.1	General .....	413
I.2.2	Reference angular step criteria .....	413
I.3	Spherical equal area grid .....	415
I.4	Spherical Fibonacci grid.....	416



I.5	Orthogonal cut grid .....	416
I.5.1	General .....	416
I.5.2	Operating band unwanted emissions .....	417
I.5.3	Spurious unwanted emissions.....	417
I.6	Wave vector space grid .....	418
I.7	Void.....	418
I.8	Void.....	418
I.9	Full sphere with sparse sampling .....	418
I.10	Beam-based directions .....	419
I.11	Peak method .....	419
I.12	Equal sector with peak average .....	419
I.13	Pre-scan .....	420
<b>Annex J (normative): Propagation conditions.....</b>		<b>421</b>
J.1	Static propagation condition.....	421
J.2	Multi-path fading propagation conditions .....	421
J.2.1	Delay profiles .....	421
J.2.1.1	Delay profiles for FR1 .....	422
J.2.1.2	Delay profiles for FR2 .....	423
J.2.2	Combinations of channel model parameters .....	424
J.2.3	MIMO channel correlation matrices.....	425
J.2.3.1	MIMO correlation matrices using Uniform Linear Array .....	425
J.2.3.1.1	Definition of MIMO correlation matrices .....	425
J.2.3.1.2	MIMO correlation matrices at high, medium and low level .....	426
J.2.3.2	Multi-antenna channel models using cross polarized antennas.....	428
J.2.3.2.1	Definition of MIMO correlation matrices using cross polarized antennas.....	429
J.2.3.2.2	Spatial correlation matrices at UE and gNB sides.....	429
J.2.3.2.2.1	Spatial correlation matrices at UE side.....	429
J.2.3.2.2.2	Spatial correlation matrices at gNB side .....	429
J.2.3.2.3	MIMO correlation matrices using cross polarized antennas .....	430
J.3	High speed train condition .....	430
J.4	Moving propagation conditions.....	435
<b>Annex K (informative): Measuring noise close to noise-floor.....</b>		<b>437</b>
<b>Annex L (normative): In-channel TX tests.....</b>		<b>438</b>
L.1	General .....	438
L.2	Basic principles .....	438
L.2.1	Output signal of the TX under test .....	438
L.2.2	Ideal signal .....	438
L.2.3	Measurement results.....	439
L.2.4	Measurement points .....	439
L.3	Pre-FFT minimization process .....	441
L.4	Timing of the FFT window .....	441
L.5	Resource element TX power .....	442
L.6	Post-FFT equalisation.....	443
L.7	EVM.....	445
L.7.0	General .....	445
L.7.1	Averaged EVM (FDD).....	445
L.7.2	Averaged EVM (TDD) for FR1 and FR2-1 .....	446

L.7.3	Averaged EVM (TDD) for FR2-2 .....	446
<b>Annex M (normative):</b>	<b>General rules for statistical testing.....</b>	<b>448</b>
M.1	Testing methodology of PUSCH performance requirements with 0.001% BLER .....	448
M.1.1	General .....	448
M.1.2	Numerical definition of the pass-fail limits for testing PUSCH 0.001% BLER.....	449
M.1.3	Theory to derive the early pass/fail limits in M.1.2 (informative).....	450
M.1.3.1	Numerical definition of the pass-fail limits for testing PUSCH 0.001% BLER .....	450
M.1.3.2	Simulation to derive the pass-fail limits for testing PUSCH 0.001% BLER .....	450
<b>Annex N (informative):</b>	<b>Change history .....</b>	<b>452</b>
History .....		470

---

# Foreword

This Technical Specification has been produced by the 3rd Generation Partnership Project (3GPP).

The contents of the present document are subject to continuing work within the TSG and may change following formal TSG approval. Should the TSG modify the contents of the present document, it will be re-released by the TSG with an identifying change of release date and an increase in version number as follows:

Version x.y.z

where:

- x the first digit:
  - 1 presented to TSG for information;
  - 2 presented to TSG for approval;
  - 3 or greater indicates TSG approved document under change control.
- y the second digit is incremented for all changes of substance, i.e. technical enhancements, corrections, updates, etc.
- z the third digit is incremented when editorial only changes have been incorporated in the document.

In the present document, modal verbs have the following meanings:

- shall** indicates a mandatory requirement to do something
- shall not** indicates an interdiction (prohibition) to do something

The constructions "shall" and "shall not" are confined to the context of normative provisions, and do not appear in Technical Reports.

The constructions "must" and "must not" are not used as substitutes for "shall" and "shall not". Their use is avoided insofar as possible, and they are not used in a normative context except in a direct citation from an external, referenced, non-3GPP document, or so as to maintain continuity of style when extending or modifying the provisions of such a referenced document.

- should** indicates a recommendation to do something
- should not** indicates a recommendation not to do something
- may** indicates permission to do something
- need not** indicates permission not to do something

The construction "may not" is ambiguous and is not used in normative elements. The unambiguous constructions "might not" or "shall not" are used instead, depending upon the meaning intended.

- can** indicates that something is possible
- cannot** indicates that something is impossible

The constructions "can" and "cannot" are not substitutes for "may" and "need not".

- will** indicates that something is certain or expected to happen as a result of action taken by an agency the behaviour of which is outside the scope of the present document
- will not** indicates that something is certain or expected not to happen as a result of action taken by an agency the behaviour of which is outside the scope of the present document
- might** indicates a likelihood that something will happen as a result of action taken by some agency the behaviour of which is outside the scope of the present document

**might not** indicates a likelihood that something will not happen as a result of action taken by some agency the behaviour of which is outside the scope of the present document

In addition:

**is** (or any other verb in the indicative mood) indicates a statement of fact

**is not** (or any other negative verb in the indicative mood) indicates a statement of fact

The constructions "is" and "is not" do not indicate requirements.

---

# 1 Scope

The present document specifies the Radio Frequency (RF) test methods and conformance requirements for NR Base Station (BS) *type 1-H*, *BS type 1-O* and *BS type 2-O*. These have been derived from, and are consistent with the radiated requirements for *BS type 1-H*, *BS type 1-O* and *BS type 2-O* in BS specification defined in TS 38.104 [2].

A *BS type 1-C* only has conducted requirements so it does not require compliance to this specification.

A *BS type 1-H* has both conducted and radiated requirements so it requires compliance to the applicable requirements of this specification and TS 38.141-1 [3].

*BS type 1-O* and *BS type 2-O* have only radiated requirements so they require compliance to this specification only.

---

# 2 References

The following documents contain provisions which, through reference in this text, constitute provisions of the present document.

- References are either specific (identified by date of publication, edition number, version number, etc.) or non-specific.
- For a specific reference, subsequent revisions do not apply.
- For a non-specific reference, the latest version applies. In the case of a reference to a 3GPP document (including a GSM document), a non-specific reference implicitly refers to the latest version of that document *in the same Release as the present document*.

- [1] 3GPP TR 21.905: "Vocabulary for 3GPP Specifications"
- [2] 3GPP TS 38.104: "NR Base Station (BS) radio transmission and reception"
- [3] 3GPP TS 38.141-1: "NR, Base Station (BS) conformance testing, Part 1: Conducted conformance testing"
- [4] Recommendation ITU-R M.1545: "Measurement uncertainty as it applies to test limits for the terrestrial component of International Mobile Telecommunications-2000"
- [5] ITU-R Recommendation SM.329: "Unwanted emissions in the spurious domain"
- [6] Void
- [7] IEC 60 721-3-3: "Classification of environmental conditions - Part 3-3: Classification of groups of environmental parameters and their severities - Stationary use at weather protected locations"
- [8] IEC 60 721-3-4: "Classification of environmental conditions - Part 3: Classification of groups of environmental parameters and their severities - Clause 4: Stationary use at non-weather protected locations"
- [9] IEC 60 721: "Classification of environmental conditions"
- [10] IEC 60 068-2-1 (2007): "Environmental testing - Part 2: Tests. Tests A: Cold"
- [11] IEC 60 068-2-2: (2007): "Environmental testing - Part 2: Tests. Tests B: Dry heat"
- [12] IEC 60 068-2-6: (2007): "Environmental testing - Part 2: Tests - Test Fc: Vibration (sinusoidal)"
- [13] Recommendation ITU-R M.328: "Spectra and bandwidth of emissions"
- [14] FCC publication number 662911: "Emissions Testing of Transmitters with Multiple Outputs in the Same Band".
- [15] ECC/DEC/(17)06: "The harmonised use of the frequency bands 1427-1452 MHz and 1492-1518 MHz for Mobile/Fixed Communications Networks Supplemental Downlink (MFCN SDL)"

- [16] Void
- [17] Void
- [18] 3GPP TS 36.104: "E-UTRA; Base Station (BS) radio transmission and reception"
- [19] 3GPP TS 38.212: "NR; Multiplexing and channel coding"
- [20] 3GPP TS 38.211: "NR; Physical channels and modulation"
- [21] 3GPP TS 38.214: "NR; Physical layer procedures for data"
- [22] 3GPP TS 38.331: "NR; Radio Resource Control (RRC) protocol specification"
- [23] 3GPP TR 38.901: "Study on channel model for frequencies from 0.5 to 100 GHz"
- [24] 3GPP TS 38.101-1: "NR; User Equipment (UE) radio transmission and reception; Part 1: Range 1 Standalone"
- [25] 3GPP TS 38.101-2: "NR; User Equipment (UE) radio transmission and reception; Part 2: Range 2 Standalone"
- [26] ERC Recommendation 74-01: "Unwanted emissions in the spurious domain"
- [27] 3GPP TR 25.942: "RF system scenarios".
- [28] ITU-T Recommendation O.150, "Equipment for the measurement of digital and analogue/digital parameters"
- [29] 3GPP TR 37.941: "Radio Frequency (RF) conformance testing background for radiated Base Station (BS) requirements"
- [30] 3GPP TS 37.145-2: "Active Antenna System (AAS) Base Station (BS) conformance testing; Part 2: radiated conformance testing".

## 3 Definitions, symbols and abbreviations

### 3.1 Definitions

For the purposes of the present document, the terms and definitions given in TR 21.905 [1] and the following apply. A term defined in the present document takes precedence over the definition of the same term, if any, in TR 21.905 [1].

**aggregated BS channel bandwidth:** the RF bandwidth in which a Base Station transmits and receives multiple contiguously aggregated carriers. The *aggregated BS channel bandwidth* is measured in MHz.

**antenna connector:** connector at the conducted interface of the *BS type 1-C*.

**Base Station RF Bandwidth:** RF bandwidth in which a base station transmits and/or receives single or multiple carrier(s) within a supported *operating band*.

NOTE 1: In single carrier operation, the *Base Station RF Bandwidth* is equal to the channel bandwidth.

**Base Station RF Bandwidth edge:** frequency of one of the edges of the *Base Station RF Bandwidth*.

**basic limit:** emissions limit relating to the power supplied by a single transmitter to a single antenna transmission line in ITU-R SM.329 [5] used for the formulation of unwanted emission requirements for FR1.

**beam:** beam (of the antenna) is the main lobe of the radiation pattern of an *antenna array*.

NOTE 2: For certain BS *antenna array*, there may be more than one beam.

**beam centre direction:** direction equal to the geometric centre of the half-power contour of the beam.

**beam direction pair:** data set consisting of the *beam centre direction* and the related *beam peak direction*.

**beam peak direction:** direction where the maximum EIRP is found.

**beamwidth:** beam which has a half-power contour that is essentially elliptical, the half-power beamwidths in the two pattern cuts that respectively contain the major and minor axis of the ellipse.

**BS channel bandwidth:** RF bandwidth supporting a single NR RF carrier with the transmission bandwidth configured in the uplink or downlink.

NOTE 3: The *BS channel bandwidth* is measured in MHz and is used as a reference for transmitter and receiver RF requirements.

NOTE 4: It is possible for the BS to transmit to and/or receive from one or more UE bandwidth parts that are smaller than or equal to the BS transmission bandwidth configuration, in any part of the BS transmission bandwidth configuration.

**BS receiver:** composite receiver function of a BS receiving in an *operating band*.

**BS type 1-C:** NR base station operating at FR1 with requirements set consisting only of conducted requirements defined at individual *antenna connectors*.

**BS type 1-H:** NR base station operating at FR1 with a requirement set consisting of conducted requirements defined at individual *TAB connectors* and OTA requirements defined at RIB.

**BS type 1-O:** NR base station operating at FR1 with a requirement set consisting only of OTA requirements defined at the RIB.

**BS type 2-O:** NR base station operating at FR2 with a requirement set consisting only of OTA requirements defined at the RIB.

**channel edge:** lowest or highest frequency of the NR carrier, separated by the *BS channel bandwidth*.

**carrier aggregation:** aggregation of two or more component carriers in order to support wider transmission bandwidths.

**carrier aggregation configuration:** a set of one or more *operating bands* across which the BS aggregates carriers with a specific set of technical requirements.

**co-location reference antenna:** a passive antenna used as reference for base station to base station co-location requirements.

**contiguous carriers:** set of two or more carriers configured in a spectrum block where there are no RF requirements based on co-existence for un-coordinated operation within the spectrum block.

**contiguous spectrum:** spectrum consisting of a contiguous block of spectrum with no *sub-block gap(s)*.

**demodulation branch:** single input of the *BS receiver* to the demodulation algorithms.

**directional requirement:** requirement which is applied in a specific direction within the OTA coverage range for the Tx and when the AoA of the incident wave of a received signal is within the *FR1 OTA REFSENS RoAoA* or *FR2 OTA REFSENS RoAoA* or the *minSENS RoAoA* as appropriate for the receiver.

**equivalent isotropic radiated power:** equivalent power radiated from an isotropic directivity device producing the same field intensity at a point of observation as the field intensity radiated in the direction of the same point of observation by the discussed device.

NOTE 5: Isotropic directivity is equal in all directions (0 dBi).

**equivalent isotropic sensitivity:** sensitivity for an isotropic directivity device equivalent to the sensitivity of the discussed device exposed to an incoming wave from a defined AoA.

NOTE 6: The sensitivity is the minimum received power level at which specific requirement is met.

NOTE 7: Isotropic directivity is equal in all directions (0 dBi).

**fractional bandwidth:** fractional bandwidth FBW is defined in percent as  $FBW = 200 \cdot \frac{F_{FBW_{high}} - F_{FBW_{low}}}{F_{FBW_{high}} + F_{FBW_{low}}} \%$ .

**highest carrier:** the carrier with the highest carrier frequency transmitted/received in a specified frequency band.

**inter-band carrier aggregation:** carrier aggregation of component carriers in different operating bands.

NOTE 8: Carriers aggregated in each band can be contiguous or non-contiguous.

**intra-band contiguous carrier aggregation:** *contiguous carriers* aggregated in the same operating band.

**intra-band non-contiguous carrier aggregation:** non-contiguous carriers aggregated in the same operating band.

**Inter-band gap:** The frequency gap between two supported consecutive operating bands.

**Inter RF Bandwidth gap:** frequency gap between two consecutive Base Station RF Bandwidths that are placed within two supported *operating bands*.

**lowest Carrier:** the carrier with the lowest carrier frequency transmitted/received in a specified frequency band.

**lower sub-block edge:** frequency at the lower edge of one *sub-block*.

NOTE 9: It is used as a frequency reference point for both transmitter and receiver requirements.

**maximum carrier TRP:** mean power level measured per RIB during the *transmitter ON period* for a specific carrier in a specified reference condition and corresponding to the declared *rated carrier TRP* ( $P_{\text{rated,c,TRP}}$ ).

**maximum transmitter TRP:** mean power level measured per RIB during the *transmitter ON period* in a specified reference condition and corresponding to the declared *rated transmitter TRP* ( $P_{\text{rated,t,TRP}}$ ).

**measurement bandwidth:** RF bandwidth in which an emission level is specified.

**minSENS:** the lowest declared EIS value for the OSDD's declared for OTA sensitivity requirement.

**minSENS RoAoA:** The reference RoAoA associated with the OSDD with the lowest declared EIS.

**multi-band RIB:** *operating band* specific RIB associated with a transmitter or receiver that is characterized by the ability to process two or more carriers in common active RF components simultaneously, where at least one carrier is



configured at a different operating band than the other carrier(s) and where this different operating band is not a sub-band or superseding-band of another supported operating band.

**multi-carrier transmission configuration:** set of one or more contiguous or non-contiguous carriers that a BS is able to transmit simultaneously according to the manufacturer's specification.

**non-contiguous spectrum:** spectrum consisting of two or more sub-blocks separated by *sub-block gap(s)*.

**operating band:** frequency range in which NR operates (paired or unpaired), that is defined with a specific set of technical requirements.

NOTE 10: The operating band(s) for a BS is declared by the manufacturer according to the designations in TS 38.104 [2].

**OTA coverage range:** a common range of directions within which TX OTA requirements that are neither specified in the *OTA peak directions sets* nor as *TRP requirement* are intended to be met.

**OTA peak directions set:** set(s) of *beam peak directions* within which certain TX OTA requirements are intended to be met, where all *OTA peak directions set(s)* are subsets of the *OTA coverage range*.

NOTE 11: The *beam peak directions* are related to a corresponding contiguous range or discrete list of *beam centre directions* by the *beam direction pairs* included in the set.

**OTA REFSENS RoAoA:** Is the RoAoA determined by the contour defined by the points at which the achieved EIS is 3dB higher than the achieved EIS in the reference direction assuming that for any AoA, the receiver gain is optimized for that AoA.

NOTE 12: This contour will be related to the average element/sub-array radiation pattern 3dB beam width.

**OTA sensitivity directions declaration:** set of manufacturer declarations comprising at least one set of declared minimum EIS values (with *BS channel bandwidth*), and related directions over which the EIS applies.

NOTE 13: All the directions apply to all the EIS values in an OSDD.

**polarization match:** condition that exists when a plane wave, incident upon an antenna from a given direction, has a polarization that is the same as the receiving polarization of the antenna in that direction.

**radiated interface boundary:** *operating band* specific radiated requirements reference where the radiated requirements apply.

NOTE 14: For requirements based on EIRP/EIS, the *radiated interface boundary* is associated to the far-field region

**Radio Bandwidth:** frequency difference between the upper edge of the highest used carrier and the lower edge of the lowest used carrier.

**rated beam EIRP:** For a declared beam and *beam direction pair*, the *rated beam EIRP* level is the maximum power that the base station is declared to radiate at the associated *beam peak direction* during the *transmitter ON period*.

**rated carrier TRP:** mean power level declared by the manufacturer per carrier, for BS operating in single carrier, multi-carrier, or carrier aggregation configurations that the manufacturer has declared to be available at the RIB during the *transmitter ON period*.

**rated transmitter TRP:** mean power level declared by the manufacturer, that the manufacturer has declared to be available at the RIB during the *transmitter ON period*.

**reference beam direction pair:** declared *beam direction pair*, including reference *beam centre direction* and reference *beam peak direction* where the reference *beam peak direction* is the direction for the intended maximum EIRP within the *OTA peak directions set*.

**receiver target:** AoA in which reception is performed by *BS types 1-H*, *BS type 1-O* and *BS types 2-O*.

**receiver target redirection range:** union of all the *sensitivity RoAoA* achievable through redirecting the *receiver target* related to particular OSDD.

**receiver target reference direction:** direction inside the *OTA sensitivity directions declaration* declared by the manufacturer for conformance testing. For an OSDD without *receiver target redirection range*, this is a direction inside the *sensitivity RoAoA*.

**reference RoAoA:** the sensitivity RoAoA associated with the receiver target reference direction for each OSDD.

**requirement set:** one of the NR base station requirement's set as defined for *BS type 1-C*, *BS type 1-H*, *BS type 1-O*, and *BS type 2-O*.

**sensitivity RoAoA:** RoAoA within the *OTA sensitivity directions declaration*, within which the declared EIS(s) of an OSDD is intended to be achieved at any instance of time for a specific BS direction setting.

**single-band RIB:** *operating band* specific RIB supporting operation either in a single *operating band* only, or in multiple *operating bands* but does not meet the conditions for a *multi-band RIB*.

**sub-band:** A sub-band of an operating band contains a part of the uplink and downlink frequency range of the operating band.

**sub-block:** one contiguous allocated block of spectrum for transmission and reception by the same base station.

NOTE 15: There may be multiple instances of sub-blocks within a *Base Station RF Bandwidth*.

**sub-block gap:** frequency gap between two consecutive sub-blocks within a *Base Station RF Bandwidth*, where the RF requirements in the gap are based on co-existence for un-coordinated operation.

**superseding-band:** A superseding-band of an operating band includes the whole of the uplink and downlink frequency range of the operating band.

**TAB connector:** *transceiver array boundary* connector.

**total radiated power:** the total power radiated by the antenna.

NOTE 16: The total radiated power is the power radiating in all direction for two orthogonal polarizations. Total radiated power is defined in both the near-field region and the far-field region.

**total RF bandwidth:** maximum sum of Base Station RF Bandwidths in all supported *operating bands*.

**transceiver array boundary:** conducted interface between the transceiver unit array and the composite antenna.

**transmission bandwidth:** RF Bandwidth of an instantaneous transmission from a UE or BS, measured in resource block units.

**transmitter OFF period:** time period during which the BS transmitter is not allowed to transmit.

**transmitter ON period:** time period during which the BS transmitter is transmitting data and/or reference symbols.

**transmitter transient period:** time period during which the transmitter is changing from the OFF period to the ON period or vice versa.

**upper sub-block edge:** frequency at the upper edge of one *sub-block*.

NOTE 17: It is used as a frequency reference point for both transmitter and receiver requirements.

## 3.2 Symbols

For the purposes of the present document, the following symbols apply:

$\beta$	Percentage of the mean transmitted power emitted outside the occupied bandwidth on the assigned channel
$BeW_{\theta}$	The beam width in $\theta$
$BeW_{\phi}$	The beam width in $\phi$
$BeW_{\theta, REFSENS}$	The beamwidth equivalent to the OTA REFSENS RoAoA in the $\theta$ -axis in degrees, applicable for FR1 only
$BeW_{\phi, REFSENS}$	The beamwidth equivalent to the OTA REFSENS RoAoA in the $\phi$ -axis in degrees, applicable for FR1 only

$BW_{\text{Channel}}$	BS channel bandwidth
$BW_{\text{Channel\_CA}}$	Aggregated BS channel bandwidth, expressed in MHz. $BW_{\text{Channel\_CA}} = F_{\text{edge\_high}} - F_{\text{edge\_low}}$
$BW_{\text{Config}}$	Transmission bandwidth configuration, expressed in MHz, where $BW_{\text{Config}} = N_{\text{RB}} \times \text{SCS} \times 12$
$BW_{\text{Contiguous}}$	Contiguous transmission bandwidth, i.e. BS channel bandwidth for single carrier or aggregated BS channel bandwidth for contiguously aggregated carriers. For non-contiguous operation within a band the term is applied per sub-block.
$BW_{\text{tot}}$	Total RF bandwidth
$\Delta f$	Separation between the channel edge frequency and the nominal -3 dB point of the measuring filter closest to the carrier frequency
$\Delta f_{\text{max}}$	$f_{\text{offset\_max}}$ minus half of the bandwidth of the measuring filter
$\Delta F_{\text{Global}}$	Global frequency raster granularity
$\Delta f_{\text{OBUE}}$	Maximum offset of the operating band unwanted emissions mask from the downlink operating band edge
$\Delta_{\text{FR2\_REFSENS}}$	Offset applied to the FR2 OTA REFSENS depending on the AoA
$\Delta f_{\text{OOB}}$	Maximum offset of the out-of-band boundary from the uplink operating band edge
$\Delta_{\text{minSENS}}$	Difference between conducted reference sensitivity and $EIS_{\text{minsens}}$
$\Delta_{\text{OTAREFSENS}}$	Difference between conducted reference sensitivity and OTA REFSENS
$\Delta F_{\text{Raster}}$	Channel raster granularity
$\Delta_{\text{sample}}$	The difference between the nominal and extreme power measurements during extreme EIRP testing, $P_{\text{max, sample, nom}} - P_{\text{max, sample, ext}}$
$\Delta_{\text{SUL}}$	Channel raster offset for SUL
$EIS_{\text{minsens}}$	The EIS declared for the minSENS RoAoA
$EIS_{\text{REFSENS}}$	OTA REFSENS EIS value
$EIS_{\text{REFSENS\_50M}}$	Declared OTA reference sensitivity basis level for FR2 based on a reference measurement channel with 50MHz BS channel bandwidth
$F_{\text{FBWhigh}}$	Highest supported frequency within supported operating band, for which fractional bandwidth support was declared
$F_{\text{FBWlow}}$	Lowest supported frequency within supported operating band, for which fractional bandwidth support was declared
$F_{\text{C}}$	RF reference frequency on the channel raster
$F_{\text{C,block, high}}$	Fc of the highest transmitted/received carrier in a sub-block
$F_{\text{C,block, low}}$	Fc of the lowest transmitted/received carrier in a sub-block
$F_{\text{C\_low}}$	The Fc of the lowest carrier, expressed in MHz
$F_{\text{C\_high}}$	The Fc of the highest carrier, expressed in MHz
$F_{\text{edge\_low}}$	The lower edge of Aggregated BS channel bandwidth, expressed in MHz. $F_{\text{edge\_low}} = F_{\text{C\_low}} - F_{\text{offset\_low}}$
$F_{\text{edge\_high}}$	The upper edge of Aggregated BS channel bandwidth, expressed in MHz. $F_{\text{edge\_high}} = F_{\text{C\_high}} + F_{\text{offset\_high}}$
$F_{\text{edge,block,low}}$	The lower sub-block edge, where $F_{\text{edge,block,low}} = F_{\text{C,block,low}} - F_{\text{offset\_low}}$
$F_{\text{edge,block,high}}$	The upper sub-block edge, where $F_{\text{edge,block,high}} = F_{\text{C,block,high}} + F_{\text{offset\_high}}$
$F_{\text{offset\_high}}$	Frequency offset from $F_{\text{C\_high}}$ to the upper Base Station RF Bandwidth edge, or from $F_{\text{C,block, high}}$ to the upper sub-block edge
$F_{\text{offset\_low}}$	Frequency offset from $F_{\text{C\_low}}$ to the lower Base Station RF Bandwidth edge, or from $F_{\text{C,block, low}}$ to the lower sub-block edge
$f_{\text{offset}}$	Separation between the channel edge frequency and the centre of the measuring filter
$f_{\text{offset\_max}}$	The offset to the frequency $\Delta f_{\text{OBUE}}$ outside the downlink operating band
$F_{\text{REF}}$	RF reference frequency
$F_{\text{REF,SUL}}$	RF reference frequency for Supplementary Uplink (SUL) bands
$F_{\text{step,X}}$	Frequency steps for the OTA transmitter spurious emissions (Category B)
$F_{\text{DL\_low}}$	The lowest frequency of the downlink operating band
$F_{\text{DL\_high}}$	The highest frequency of the downlink operating band
$F_{\text{UL\_low}}$	The lowest frequency of the uplink operating band
$F_{\text{UL\_high}}$	The highest frequency of the uplink operating band
$I_{\text{uant}}$	gNB internal logical interface between the implementation specific O&M function and the RET antennas and TMAs control unit function of the gNB
$N_{\text{cells}}$	The declared number corresponding to the minimum number of cells that can be transmitted by an BS type 1-H in a particular operating band
$N_{\text{RB}}$	Transmission bandwidth configuration, expressed in resource blocks
$N_{\text{REF}}$	NR Absolute Radio Frequency Channel Number (NR-ARFCN)
$N_{\text{RXU,active}}$	The number of active receiver units. The same as the number of demodulation branches to which compliance is declared for chapter 8 performance requirements
$P_{\text{EM,n50,ind}}$	Declared emission level for Band n50 in the band 1518-1559 MHz; ind = a, b

$P_{\max,c,EIRP}$	The maximum carrier EIRP when the BS is configured at the maximum rated carrier TRP ( $P_{\text{rated},c,TRP}$ )
$P_{\max,c,EIRP,extreme}$	The maximum carrier EIRP when the BS is configured at the maximum rated carrier TRP ( $P_{\text{rated},c,TRP}$ ) under extreme conditions, either measured directly or calculated
$P_{\max,c,TRP}$	<i>Maximum carrier TRP</i> measured at the RIB(s), and corresponding to the declared <i>rated carrier TRP</i> ( $P_{\text{rated},c,TRP}$ )
$P_{\max,sample,nom}$	The measured sample power in extreme conditionals chamber when the BS is configured at the rated carrier TRP ( $P_{\text{rated},c,TRP}$ ), under nominal conditions
$P_{\max,sample,ext}$	The measured sample power in extreme conditionals chamber when the BS is configured at the rated carrier TRP ( $P_{\text{rated},c,TRP}$ ), under extreme conditions
$P_{\text{rated},c,EIRP}$	The rated carrier EIRP when the BS is configured at the rated carrier TRP ( $P_{\text{rated},c,TRP}$ )
$P_{\text{rated},c,FBW\text{high}}$	The rated carrier EIRP for the higher supported frequency range within supported <i>operating band</i> , for which <i>fractional bandwidth</i> support was declared
$P_{\text{rated},c,FBW\text{low}}$	The rated carrier EIRP for the lower supported frequency range within supported <i>operating band</i> , for which <i>fractional bandwidth</i> support was declared
$P_{\text{rated},c,TRP}$	Rated carrier TRP declared per RIB
$P_{\text{rated},t,TRP}$	<i>Rated transmitter TRP</i> declared per RIB
$P_{\text{REFSENS}}$	Conducted reference Sensitivity power level
$SS_{\text{REF}}$	SS block reference frequency position
$TRP_{\text{Estimate}}$	Numerically approximated TRP
$TT_{\text{OTA}}$	Test tolerance for OTA requirements
$W_{\text{gap}}$	Sub-block gap or Inter RF Bandwidth gap size
$\theta$	The angle in the reference coordinate system between the projection of the x/y plane and the radiation vector defined between $-90^\circ$ and $90^\circ$ . $0^\circ$ represents the y/z plane. The angle is aligned with the down-tilt angle
$\phi$	The angle in the reference coordinate system between the x-axis and the projection of the radiation vector onto the x/y plane defined between $-180^\circ$ and $180^\circ$

### 3.3 Abbreviations

For the purposes of the present document, the abbreviations given in TR 21.905 [1] and the following apply. An abbreviation defined in the present document takes precedence over the definition of the same abbreviation, if any, in TR 21.905 [1].

AA	Antenna Array
ACLR	Adjacent Channel Leakage Ratio
ACS	Adjacent Channel Selectivity
AoA	Angle of Arrival
ATG	Air-to-Ground
AWGN	Additive White Gaussian Noise
BS	Base Station
BW	Bandwidth
CA	Carrier Aggregation
CACLR	Cumulative ACLR
CATR	Compact Antenna Test Range
CPE	Common Phase Error
CP-OFDM	Cyclic Prefix-OFDM
CLTA	Co-Location Test Antenna
CW	Continuous Wave
DFT-s-OFDM	Discrete Fourier Transform-spread-OFDM
DM-RS	Demodulation Reference Signal
EUT	Equipment Under Test
EIRP	Equivalent Isotropic Radiated Power
EIS	Equivalent Isotropic Sensitivity
FBW	Fractional Bandwidth
FR	Frequency Range
GSCN	Global Synchronization Channel Number
ICS	In-Channel Selectivity
ITU-R	Radiocommunication Sector of the International Telecommunication Union
LA	Local Area
LNA	Low Noise Amplifier

MR	Medium Range
NR	New Radio
NR-ARFCN	NR Absolute Radio Frequency Channel Number
OBUE	Operating Band Unwanted Emissions
OCC	Orthogonal Covering Code
OSDD	OTA Sensitivity Directions Declaration
OTA	Over The Air
PT-RS	Phase Tracking Reference Signal
PWS	Plane Wave Synthesizer
RB	Resource Block
RDN	Radio Distribution Network
REFSENS	Reference Sensitivity
RIB	Radiated Interface Boundary
RMS	Root Mean Square (value)
RS	Reference Signal
RV	Redundancy Version
RX	Receiver
RoAoA	Range of Angles of Arrival
SCS	Sub-Carrier Spacing
SSB	Synchronization Signal Block
TAB	Transceiver Array Boundary
TAE	Time Alignment Error
TDD	Time Division Duplex
TDL	Tapped Delay Line
TRP	Total Radiated Power
TT	Test Tolerance
UCI	Uplink Control Information
ZF	Zero Forcing

---

## 4 General radiated test conditions and declarations

### 4.1 Measurement uncertainties and test requirements

#### 4.1.1 General

The requirements of this clause apply to all applicable tests in TS 38.141-2 (the present document), i.e. to all radiated tests defined in FR1 for *BS type 1-H*, *BS type 1-O* and radiated tests defined in FR2 for *BS type 2-O*. The frequency ranges FR1 and FR2 are defined in clause 5.1 of TS 38.104 [2].

The minimum requirements are given in TS 38.104 [2]. Test Tolerances for the radiated test requirements ( $TT_{OTA}$ ) explicitly stated in the present document are given in annex C.

Test Tolerances are individually calculated for each test. Test Tolerances are used to relax the minimum requirements to create test requirements.

When a test requirement differs from the corresponding minimum requirement, then the Test Tolerance applied for the test is non-zero. The Test Tolerance for the test and the explanation of how the minimum requirement has been relaxed by the Test Tolerance are given in annex C.

The requirements are classified according to spatial characteristics as shown in table 4.1.1-1 and table 4.1.1-2.

Table 4.1.1-1: Overview of radiated Tx requirements

Tx requirement		Classification	Coverage range		Number of conformance directions
			FR1	FR2	
Radiated transmit power		Directional	OTA peak directions set	OTA peak directions set	5
OTA BS output power		TRP	See annex I		
OTA output power dynamics		Directional	OTA peak directions set	OTA peak directions set	1
OTA transmitter OFF power		Co-location	See clause 4.12	N/A	See clause 4.12
		Directional	N/A	OTA peak directions set (Note 2)	1
OTA transient period		Co-location	See clause 4.12	N/A	See clause 4.12
		Directional	N/A	OTA peak directions set (Note 2)	1
OTA modulation quality		Directional	OTA coverage range	OTA coverage range	5
OTA frequency error		Directional	OTA coverage range	OTA coverage range	1
OTA time alignment error		Directional	OTA coverage range	OTA coverage range	1
OTA occupied bandwidth		Directional	OTA coverage range	OTA coverage range	1
OTA ACLR		TRP	N/A	N/A	See annex I
OTA operating band unwanted emission		TRP	N/A	N/A	See annex I
OTA transmitter spurious emission	General requirement	TRP	N/A	N/A	See annex I
	Protection of the BS receiver of own or different BS	Co-location	See clause 4.12	N/A	See clause 4.12
	Additional spurious emissions	TRP	N/A	N/A	See annex I
	Co-location with other base stations	Co-location	See clause 4.12	N/A	See clause 4.12
OTA transmitter intermodulation		Co-location	See clause 4.12	N/A	See clause 4.12
NOTE 1: Directional requirement does not imply one compliance direction only. The directional requirement applies to a single direction at a time.					
NOTE 2: For FR2, RF Core requirements are defined on TRP levels. Conformance requirements are verified by EIRP measurements in the reference direction.					

Table 4.1.1-2: Overview of radiated Rx requirements

Rx requirement		Classification	Applicability levels		Coverage range		Number of conformance directions
			FR1	FR2	FR1	FR2	
OTA sensitivity		Directional	Minimum EIS	N/A	OSDD	N/A	5
OTA reference sensitivity		Directional	OTA REFSENS	OTA REFSENS	OTA REFSENS RoAoA		5
OTA Dynamic range		Directional	OTA REFSENS	N/A	OTA REFSENS RoAoA	N/A	1
OTA adjacent channel selectivity		Directional	minSENS	OTA REFSENS	minSENS RoAoA	OTA REFSENS RoAoA	1
OTA in-band blocking		Directional	OTA REFSENS and minSENS	OTA REFSENS	OTA REFSENS RoAoA and minSENS RoAoA	OTA REFSENS RoAoA	5
OTA out-of-band blocking	General requirement	Directional	minSENS	OTA REFSENS	minSENS RoAoA	OTA REFSENS RoAoA	1
	Co-location with other base stations	Co-location (Note 2)	minSENS	N/A	minSENS RoAoA	N/A	1
OTA receiver spurious emissions		TRP	See clause 7.7	See clause 7.7	N/A	N/A	See annex I
OTA receiver intermodulation		Directional	OTA REFSENS and minSENS	OTA REFSENS	OTA REFSENS RoAoA and minSENS RoAoA	OTA REFSENS RoAoA	1
OTA in-channel selectivity		Directional	minSENS	OTA REFSENS	minSENS RoAoA	OTA REFSENS RoAoA	1
NOTE 1: Directional requirement does not imply one compliance direction only. The directional requirement applies to a single direction at a time.							
NOTE 2: The compliance direction for co-location blocking is applicable for the wanted signal only but not the interfering signal.							

## 4.1.2 Acceptable uncertainty of OTA Test System

### 4.1.2.1 General

The maximum acceptable uncertainty of the OTA Test System is specified below for each radiated test defined explicitly in the present specification, where appropriate.

The OTA Test System shall enable the stimulus signals in the test case to be adjusted to within the specified tolerance and the EUT to be measured with an uncertainty not exceeding the specified values. All tolerances and uncertainties are absolute values, and are valid for a confidence level of 95 %, unless otherwise stated.

A confidence level of 95% is the measurement uncertainty tolerance interval for a specific measurement that contains 95% of the performance of a population of test equipment.

For details on measurement uncertainty budget calculation, OTA measurement methodology description (including calibration and measurement stage for each test range), MU budget format and its contributions, refer to TR 37.941 [29].



#### 4.1.2.2 Measurement of transmitter

The maximum OTA Test System uncertainty for OTA transmitter tests minimum requirements are given in tables 4.1.2.2-1 and 4.1.2.2-2. Details for derivation of OTA Test System uncertainty are given in corresponding clauses in TR 37.941 [29].

Table 4.1.2.2-1: Maximum OTA Test System uncertainty for FR1 OTA transmitter tests

Clause	Maximum OTA Test System uncertainty
6.2 Radiated transmit power	Normal condition: $\pm 1.1$ dB, $f \leq 3$ GHz $\pm 1.3$ dB, $3 \text{ GHz} < f \leq 7.125$ GHz $\pm 1.8$ dB for band n96 Extreme condition: $\pm 2.5$ dB, $f \leq 3$ GHz $\pm 2.6$ dB, $3 \text{ GHz} < f \leq 7.125$ GHz
6.3 OTA base station output power	$\pm 1.4$ dB, $f \leq 3.0$ GHz $\pm 1.5$ dB, $3.0 \text{ GHz} < f \leq 4.2$ GHz $\pm 1.5$ dB, $4.2 \text{ GHz} < f \leq 7.125$ GHz
6.4.2 OTA RE power control dynamic range	N/A
6.4.3 OTA total power dynamic range	$\pm 0.4$ dB
6.5.1 OTA transmitter OFF power	$\pm 3.4$ dB, $f \leq 3.0$ GHz $\pm 3.6$ dB, $3.0 \text{ GHz} < f \leq 7.125$ GHz(NOTE 1)
6.5.2 OTA transmitter transient period	N/A
6.6.2 OTA frequency error	$\pm 12$ Hz
6.6.3 OTA modulation quality	$\pm 1$ %
6.6.4 OTA time alignment error	$\pm 25$ ns
6.7.2 OTA occupied bandwidth	$\pm 100$ kHz, $BW_{\text{Channel}}$ 5 MHz, 10 MHz $\pm 300$ kHz, $BW_{\text{Channel}}$ 15 MHz, 20 MHz, 25 MHz, 30 MHz, 35 MHz, 40 MHz, 45 MHz, 50 MHz $\pm 600$ kHz, $BW_{\text{Channel}}$ 60 MHz, 70 MHz, 80 MHz, 90 MHz, 100 MHz
6.7.3 OTA ACLR/CACLR	$f \leq 3.0$ GHz $\pm 1$ dB, $BW \leq 20$ MHz $\pm 1$ dB, $BW > 20$ MHz  $3.0 \text{ GHz} < f \leq 7.125$ GHz $\pm 1.2$ dB, $BW \leq 20$ MHz $\pm 1.2$ dB, $BW > 20$ MHz  Absolute power $\pm 2.2$ dB, $f \leq 3.0$ GHz Absolute power $\pm 2.7$ dB, $3.0 \text{ GHz} < f \leq 4.2$ GHz Absolute power $\pm 2.7$ dB, $4.2 \text{ GHz} < f \leq 7.125$ GHz
6.7.4 OTA operating band unwanted emissions	Absolute power $\pm 1.8$ dB, $f \leq 3.0$ GHz Absolute power $\pm 2$ dB, $3.0 \text{ GHz} < f \leq 4.2$ GHz Absolute power $\pm 2$ dB, $4.2 \text{ GHz} < f \leq 6.0$ GHz
6.7.5.2 OTA transmitter spurious emissions, mandatory requirements	$\pm 2.3$ dB, $30 \text{ MHz} < f \leq 6$ GHz $\pm 4.2$ dB, $6 \text{ GHz} < f \leq 26$ GHz
6.7.5.3 OTA transmitter spurious emissions, protection of BS receiver	$\pm 3.1$ dB, $f \leq 3$ GHz $\pm 3.3$ dB, $3 \text{ GHz} < f \leq 4.2$ GHz $\pm 3.4$ , $4.2 \text{ GHz} < f \leq 7.125$ GHz(NOTE 1)
6.7.5.4 OTA transmitter spurious emissions, additional spurious emissions requirements	$\pm 2.6$ dB, $f \leq 3$ GHz $\pm 3.0$ , $3 \text{ GHz} < f \leq 4.2$ GHz $\pm 3.5$ , $4.2 \text{ GHz} < f \leq 6$ GHz
6.7.5.5 OTA transmitter spurious emissions, co-location	$\pm 3.1$ dB, $f \leq 3$ GHz $\pm 3.3$ dB, $3 \text{ GHz} < f \leq 4.2$ GHz $\pm 3.4$ , $4.2 \text{ GHz} < f \leq 7.125$ GHz(NOTE 1)
6.8 OTA transmitter intermodulation	The value below applies only to the interfering signal and is unrelated to the measurement uncertainty of the tests in 6.7.3 (ACLR), 6.7.4 (OBUE) and 6.7.5 (spurious emissions) which have to be carried out in the presence of the interferer. $\pm 3.2$ dB, $f \leq 3.0$ GHz $\pm 3.4$ dB, $3.0 \text{ GHz} < f \leq 4.2$ GHz $\pm 3.5$ dB, $4.2 \text{ GHz} < f \leq 6$ GHz (NOTE 1)
NOTE 1:	Fulfilling the criteria for CLTA selection and placement in clause 4.12 is deemed sufficient for the test purposes. When these criteria are met, the measurement uncertainty related to the selection of the co-location test antenna and its alignment as specified in the appropriate measurement uncertainty budget in TR 37.941 [29] shall be used for evaluating the test system uncertainty.
NOTE 2:	Test system uncertainty values are applicable for normal condition unless otherwise stated.

**Table 4.1.2.2-2: Maximum OTA Test System uncertainty for FR2 OTA transmitter tests**

Clause	Maximum OTA Test System uncertainty
6.2 Radiated transmit power	Normal condition: $\pm 1.7$ dB, 24.25 GHz $\leq f \leq$ 29.5 GHz $\pm 2.0$ dB, 37 GHz $\leq f \leq$ 43.5 GHz $\pm 2.2$ dB, 43.5 GHz $< f \leq$ 48.2 GHz $\pm 3.0$ dB, 52.6 GHz $\leq f \leq$ 71 GHz Extreme condition: $\pm 3.1$ dB, 24.25 GHz $\leq f \leq$ 29.5 GHz $\pm 3.3$ dB, 37 GHz $\leq f \leq$ 43.5 GHz $\pm 3.5$ dB, 43.5 GHz $< f \leq$ 48.2 GHz $\pm 3.9$ dB, 52.6 GHz $\leq f \leq$ 71 GHz
6.3 OTA base station output power	$\pm 2.1$ dB, 24.25 GHz $\leq f \leq$ 29.5 GHz $\pm 2.4$ dB, 37 GHz $\leq f \leq$ 43.5 GHz $\pm 2.6$ dB, 43.5 GHz $< f \leq$ 48.2 GHz $\pm 3.2$ dB, 52.6 GHz $\leq f \leq$ 71 GHz
6.4.2 OTA RE power control dynamic range	N/A
6.4.3 OTA total power dynamic range	$\pm 0.4$ dB
6.5.1 OTA transmitter OFF power	$\pm 2.9$ dB, 24.25 GHz $\leq f \leq$ 29.5 GHz $\pm 3.3$ dB, 37 GHz $\leq f \leq$ 43.5 GHz $\pm 3.6$ dB, 43.5 GHz $< f \leq$ 48.2 GHz $\pm 5.6$ dB, 52.6 GHz $\leq f \leq$ 71 GHz
6.5.2 OTA transmitter transient period	N/A
6.6.2 OTA frequency error	$\pm 12$ Hz
6.6.3 OTA modulation quality	1%
6.6.4 OTA time alignment error	$\pm 25$ ns
6.7.2 OTA occupied bandwidth	600 kHz
6.7.3 OTA ACLR	Relative ACLR: $\pm 2.3$ dB, 24.25 GHz $\leq f \leq$ 29.5 GHz $\pm 2.6$ dB, 37 GHz $\leq f \leq$ 43.5 GHz $\pm 2.8$ dB, 43.5 GHz $< f \leq$ 48.2 GHz $\pm 4.6$ dB, 52.6 GHz $\leq f \leq$ 71 GHz Absolute ACLR: $\pm 2.7$ dB, 24.25 GHz $\leq f \leq$ 29.5 GHz $\pm 2.7$ dB, 37 GHz $\leq f \leq$ 43.5 GHz $\pm 2.9$ dB, 43.5 GHz $< f \leq$ 48.2 GHz $\pm 4.7$ dB, 52.6 GHz $\leq f \leq$ 71 GHz
6.7.4 OTA operating band unwanted emissions	$\pm 2.7$ dB, 24.25 GHz $\leq f \leq$ 29.5 GHz $\pm 2.7$ dB, 37 GHz $\leq f \leq$ 43.5 GHz $\pm 2.9$ dB, 43.5 GHz $< f \leq$ 48.2 GHz $\pm 4.7$ dB, 52.6 GHz $\leq f \leq$ 71 GHz
6.7.5.2 OTA transmitter spurious emissions, mandatory requirements	$\pm 2.3$ dB, 30 MHz $\leq f \leq$ 6 GHz $\pm 2.7$ dB, 6 GHz $< f \leq$ 40 GHz $\pm 5.0$ dB, 40 GHz $< f \leq$ 60 GHz $\pm 5.3$ dB, 60 GHz $< f \leq$ 110 GHz $\pm 5.9$ dB, 110 GHz $< f \leq$ 142 GHz
6.7.5.4 OTA transmitter spurious emissions, additional requirements	$\pm 2.3$ dB, 30 MHz $\leq f \leq$ 6 GHz $\pm 2.7$ dB, 6 GHz $< f \leq$ 40 GHz $\pm 5.0$ dB, 40 GHz $< f \leq$ 60 GHz $\pm 5.3$ dB, 60 GHz $< f \leq$ 110 GHz $\pm 5.9$ dB, 110 GHz $< f \leq$ 142 GHz
NOTE: Test system uncertainty values are applicable for normal condition unless otherwise stated.	

#### 4.1.2.3 Measurement of receiver

The maximum OTA Test System uncertainty for OTA receiver tests minimum requirements are given in tables 4.1.2.3-1 and 4.1.2.3-2. Details for derivation of OTA Test System uncertainty are given in corresponding clauses in TR 37.941 [29].

**Table 4.1.2.3-1: Maximum OTA Test System uncertainty for FR1 OTA receiver tests**

Clause	Maximum OTA Test System uncertainty
7.2 OTA sensitivity	$\pm 1.3$ dB, $f \leq 3.0$ GHz $\pm 1.4$ dB, $3.0$ GHz $< f \leq 4.2$ GHz $\pm 1.6$ dB, $4.2$ GHz $< f \leq 6.0$ GHz $\pm 1.9$ dB, $6.0$ GHz $< f \leq 7.125$ GHz $\pm 1.9$ dB for band n96
7.3 OTA reference sensitivity level	$\pm 1.3$ dB, $f \leq 3.0$ GHz $\pm 1.4$ dB, $3.0$ GHz $< f \leq 4.2$ GHz $\pm 1.6$ dB, $4.2$ GHz $< f \leq 6.0$ GHz $\pm 1.9$ dB, $6.0$ GHz $< f \leq 7.125$ GHz
7.4 OTA dynamic range	$\pm 0.3$ dB
7.5.1 OTA adjacent channel selectivity	$\pm 1.7$ dB, $f \leq 3.0$ GHz $\pm 2.1$ dB, $3.0$ GHz $< f \leq 4.2$ GHz $\pm 2.4$ dB, $4.2$ GHz $< f \leq 6.0$ GHz $\pm 2.8$ dB, $6.0$ GHz $< f \leq 7.125$ GHz
7.5.2 In-band blocking (General)	$\pm 1.9$ dB, $f \leq 3.0$ GHz $\pm 2.2$ dB, $3.0$ GHz $< f \leq 4.2$ GHz $\pm 2.5$ dB, $4.2$ GHz $< f \leq 6.0$ GHz $\pm 2.9$ dB, $6.0$ GHz $< f \leq 7.125$ GHz
7.5.2 In-band blocking (Narrowband)	$\pm 1.7$ dB, $f \leq 3.0$ GHz $\pm 2.1$ dB, $3.0$ GHz $< f \leq 4.2$ GHz $\pm 2.4$ dB, $4.2$ GHz $< f \leq 6.0$ GHz
7.6 OTA out-of-band blocking (General)	$f_{\text{wanted}} \leq 3.0$ GHz: $\pm 2.0$ dB, $f_{\text{interferer}} \leq 3.0$ GHz $\pm 2.1$ dB, $3.0$ GHz $< f_{\text{interferer}} \leq 6.0$ GHz $\pm 3.5$ dB, $6.0$ GHz $< f_{\text{interferer}} \leq 12.75$ GHz  $3$ GHz $< f_{\text{wanted}} \leq 4.2$ GHz: $\pm 2.0$ dB, $f_{\text{interferer}} \leq 3.0$ GHz $\pm 2.1$ dB, $3.0$ GHz $< f_{\text{interferer}} \leq 6.0$ GHz $\pm 3.6$ dB, $6.0$ GHz $< f_{\text{interferer}} \leq 12.75$ GHz  $4.2$ GHz $< f_{\text{wanted}} \leq 7.125$ GHz: $\pm 2.2$ dB, $f_{\text{interferer}} \leq 3.0$ GHz $\pm 2.3$ dB, $3.0$ GHz $< f_{\text{interferer}} \leq 6.0$ GHz $\pm 3.6$ dB, $6.0$ GHz $< f_{\text{interferer}} \leq 12.75$ GHz
7.6 OTA out-of-band blocking (Co-location) (NOTE 1)	$f_{\text{wanted}} \leq 3.0$ GHz: $\pm 3.4$ dB, $f_{\text{interferer}} \leq 3.0$ GHz $\pm 3.5$ dB, $3.0$ GHz $< f_{\text{interferer}} \leq 4.2$ GHz $\pm 3.7$ dB, $4.2$ GHz $< f_{\text{interferer}} \leq 6.0$ GHz  $3$ GHz $< f_{\text{wanted}} \leq 4.2$ GHz: $\pm 3.5$ dB, $f_{\text{interferer}} \leq 3.0$ GHz $\pm 3.6$ dB, $3.0$ GHz $< f_{\text{interferer}} \leq 4.2$ GHz $\pm 3.7$ dB, $4.2$ GHz $< f_{\text{interferer}} \leq 6.0$ GHz  $4.2$ GHz $< f_{\text{wanted}} \leq 6.0$ GHz: $\pm 3.6$ dB, $f_{\text{interferer}} \leq 3.0$ GHz $\pm 3.7$ dB, $3.0$ GHz $< f_{\text{interferer}} \leq 4.2$ GHz $\pm 3.8$ dB, $4.2$ GHz $< f_{\text{interferer}} \leq 6.0$ GHz  $6.0$ GHz $< f \leq 7.125$ GHz: $\pm 3.6$ dB, $f_{\text{interferer}} \leq 3.0$ GHz $\pm 3.8$ dB, $3.0$ GHz $< f_{\text{interferer}} \leq 4.2$ GHz $\pm 3.9$ dB, $4.2$ GHz $< f_{\text{interferer}} \leq 6.0$ GHz
7.7 OTA receiver spurious emissions	$\pm 2.5$ dB, $30$ MHz $\leq f \leq 6.0$ GHz $\pm 4.2$ dB, $6.0$ GHz $< f \leq 26$ GHz
7.8 OTA receiver intermodulation	$\pm 2.0$ dB, $f \leq 3.0$ GHz $\pm 2.6$ dB, $3.0$ GHz $< f \leq 4.2$ GHz $\pm 3.2$ dB, $4.2$ GHz $< f \leq 6.0$ GHz $\pm 3.5$ dB, $6.0$ GHz $< f \leq 7.125$ GHz
7.9 OTA in-channel selectivity	$\pm 1.7$ dB, $f \leq 3.0$ GHz $\pm 2.1$ dB, $3.0$ GHz $< f \leq 4.2$ GHz $\pm 2.4$ dB, $4.2$ GHz $< f \leq 6.0$ GHz $\pm 2.8$ dB, $6.0$ GHz $< f \leq 7.125$ GHz

NOTE 1: Fulfilling the criteria for CLTA selection and placement in clause 4.12 is deemed sufficient for the test purposes. When these criteria are met, the measurement uncertainty related to the selection of the co-location test antenna and its alignment as specified in the appropriate measurement uncertainty budget in TR 37.941 [29], shall be used for evaluating the test system uncertainty.

NOTE 2: Test system uncertainty values are applicable for normal condition unless otherwise stated.

**Table 4.1.2.3-2: Maximum OTA Test System uncertainty for FR2 OTA receiver tests**

Clause	Maximum OTA Test System uncertainty
7.3 OTA reference sensitivity level	$\pm 2.4$ dB, 24.25 GHz < f $\leq$ 29.5 GHz $\pm 2.4$ dB, 37 GHz < f $\leq$ 43.5 GHz $\pm 3.5$ dB, 43.5 GHz < f $\leq$ 48.2 GHz $\pm 3.0$ dB, 52.6 GHz $\leq$ f $\leq$ 71 GHz
7.5.1 OTA adjacent channel selectivity	$\pm 3.4$ dB, 24.25 GHz < f $\leq$ 29.5 GHz $\pm 3.4$ dB, 37 GHz < f $\leq$ 43.5 GHz $\pm 5.1$ dB, 43.5 GHz < f $\leq$ 48.2 GHz $\pm 4.0$ dB, 52.6 GHz $\leq$ f $\leq$ 71 GHz
7.5.2 In-band blocking (General)	$\pm 3.4$ dB, 24.25 GHz < f $\leq$ 29.5 GHz $\pm 3.4$ dB, 37 GHz < f $\leq$ 43.5 GHz $\pm 5.1$ dB, 43.5 GHz < f $\leq$ 48.2 GHz $\pm 4.0$ dB, 52.6 GHz $\leq$ f $\leq$ 71 GHz
7.6 OTA out-of-band blocking	$\pm 3.6$ dB, 24.25 GHz < f $\leq$ 43.5 GHz $\pm 4.5$ dB, 43.5 GHz < f $\leq$ 48.2 GHz $\pm 4.0$ dB, 52.6 GHz $\leq$ f $\leq$ 142 GHz
7.7 OTA receiver spurious emissions	$\pm 2.5$ dB, 30 MHz $\leq$ f $\leq$ 6 GHz $\pm 2.7$ dB, 6 GHz < f $\leq$ 40 GHz $\pm 5.0$ dB, 40 GHz < f $\leq$ 60 GHz $\pm 5.3$ dB, 60 GHz < f $\leq$ 110 GHz $\pm 5.9$ dB, 110 GHz < f $\leq$ 142 GHz
7.8 OTA receiver intermodulation	$\pm 3.9$ dB, 24.25 GHz < f $\leq$ 29.5 GHz $\pm 3.9$ dB, 37 GHz < f $\leq$ 43.5 GHz $\pm 5.4$ dB, 43.5 GHz < f $\leq$ 48.2 GHz $\pm 4.5$ dB, 52.6 GHz $\leq$ f $\leq$ 71 GHz
7.9 OTA in-channel selectivity	$\pm 3.4$ dB, 24.25 GHz < f $\leq$ 29.5 GHz $\pm 3.4$ dB, 37 GHz < f $\leq$ 43.5 GHz $\pm 5.1$ dB, 43.5 GHz < f $\leq$ 48.2 GHz $\pm 4.0$ dB, 52.6 GHz $\leq$ f $\leq$ 71 GHz
NOTE:	Test system uncertainty values are applicable for normal condition unless otherwise stated.

## 4.1.2.4 Measurement of performance requirement

**Table 4.1.2.4-1: Maximum OTA Test System uncertainty for FR1 OTA performance requirements**

Clause	Maximum OTA Test System uncertainty	Derivation of OTA Test System uncertainty
8 PUSCH, PUCCH, PRACH with single antenna port and fading channel	$\pm 0.6$ dB	Overall system uncertainty for fading conditions comprises two quantities: 1. Signal-to-noise ratio uncertainty 2. Fading profile power uncertainty  Items 1 and 2 are assumed to be uncorrelated so can be root sum squared: Test System uncertainty = SQRT (Signal-to-noise ratio uncertainty <sup>2</sup> + Fading profile power uncertainty <sup>2</sup> ) Signal-to-noise ratio uncertainty $\pm 0.3$ dB Fading profile power uncertainty $\pm 0.5$ dB
8 PUSCH, PRACH with single antenna port and AWGN	$\pm 0.3$ dB	Signal-to-noise ratio uncertainty $\pm 0.3$ dB
8 PUSCH with two antenna port and fading channel	$\pm 0.8$ dB	Overall system uncertainty for fading conditions comprises two quantities: 1. Signal-to-noise ratio uncertainty 2. Fading profile power uncertainty  Items 1 and 2 are assumed to be uncorrelated so can be root sum squared: Test System uncertainty = SQRT (Signal-to-noise ratio uncertainty <sup>2</sup> + Fading profile power uncertainty <sup>2</sup> ) Signal-to-noise ratio uncertainty $\pm 0.3$ dB Fading profile power uncertainty $\pm 0.7$ dB for MIMO
NOTE: Test system uncertainty values are applicable for normal condition unless otherwise stated.		

**Table 4.1.2.4-2: Maximum OTA Test System uncertainty for FR2 OTA performance requirements**

Clause	Maximum OTA Test System uncertainty	Derivation of OTA Test System uncertainty
8 PUSCH, PUCCH, PRACH with single antenna port and fading channel	$\pm 0.6$ dB	Overall system uncertainty for fading conditions comprises two quantities: 1. Signal-to-noise ratio uncertainty 2. Fading profile power uncertainty  Items 1 and 2 are assumed to be uncorrelated so can be root sum squared: Test System uncertainty = SQRT (Signal-to-noise ratio uncertainty <sup>2</sup> + Fading profile power uncertainty <sup>2</sup> ) Signal-to-noise ratio uncertainty $\pm 0.3$ dB Fading profile power uncertainty $\pm 0.5$ dB
8 PRACH with single antenna port and AWGN	$\pm 0.3$ dB	Signal-to-noise ratio uncertainty $\pm 0.3$ dB
8 PUSCH with two antenna port and fading channel	$\pm 0.8$ dB	Overall system uncertainty for fading conditions comprises two quantities: 1. Signal-to-noise ratio uncertainty 2. Fading profile power uncertainty  Items 1 and 2 are assumed to be uncorrelated so can be root sum squared: Test System uncertainty = SQRT (Signal-to-noise ratio uncertainty <sup>2</sup> + Fading profile power uncertainty <sup>2</sup> ) Signal-to-noise ratio uncertainty $\pm 0.3$ dB Fading profile power uncertainty $\pm 0.7$ dB for MIMO
NOTE: Test system uncertainty values are applicable for normal condition unless otherwise stated.		

### 4.1.3 Interpretation of measurement results

The measurement results returned by the OTA Test System are compared - without any modification - against the test requirements as defined by the Shared Risk principle in Recommendation ITU-R M.1545 [4].

The actual measurement uncertainty of the OTA Test System for the measurement of each parameter shall be included in the test report.

The recorded value for the OTA Test System uncertainty shall be, for each OTA measurement, equal to or lower than the appropriate figure in clause 4.1.2 of this specification.

If the OTA Test System for an OTA test is known to have a measurement uncertainty greater than that specified in clause 4.1.2, it is still permitted to use this apparatus provided that an adjustment is made as follows:

Any additional uncertainty in the OTA Test System over and above that specified in clause 4.1.2 shall be used to tighten the OTA test requirement, making the test harder to pass. For some tests e.g. receiver tests, this may require modification of stimulus signals. This procedure will ensure that an OTA Test System not compliant with clause 4.1.2 does not increase the chance of passing a EUT where that device would otherwise have failed the test if an OTA Test System compliant with clause 4.1.2 had been used.

## 4.2 Radiated requirement reference points

Radiated characteristics for *BS type 1-H*, *BS type 1-O* and *BS type 2-O* are defined over the air (OTA) where the operating band specific radiated interface is referred to as the *Radiated Interface Boundary* (RIB). Radiated requirements are also referred to as OTA requirements. The (spatial) characteristics in which the OTA requirements



apply are detailed for each requirement. For *BS type 1-H* the requirements are defined for two points of reference, signified by radiated requirements at the RIB and the conducted requirements at *transceiver array boundary* (TAB). The OTA requirements of *BS type 1-H* are tested in the far field (Fraunhofer) region.

General architecture and reference points of *BS type 1-H*, *BS type 1-O* and *BS type 2-O* are presented on the following figures 4.2-1 – 4.2-2.

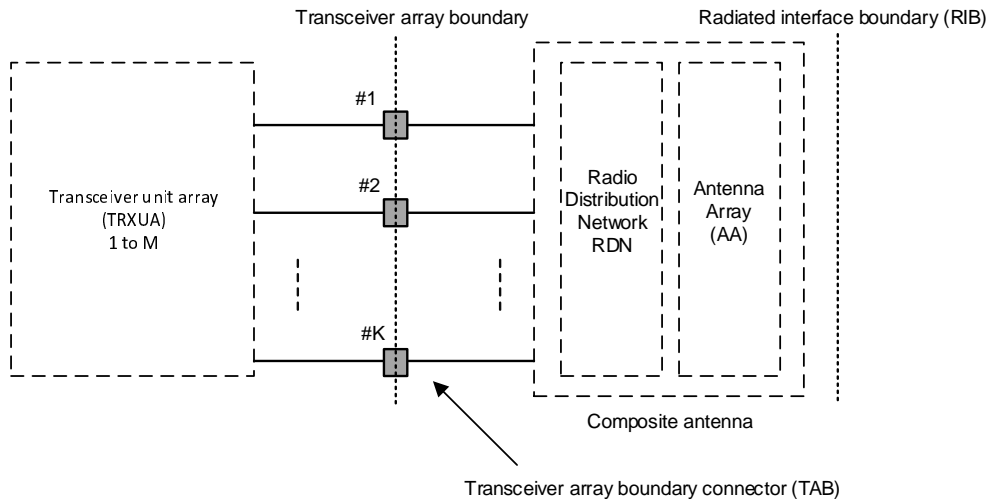

**Figure 4.2-1: General architecture of *BS type 1-H***

This specification details only radiated test requirements and hence only requires the radiated reference points.

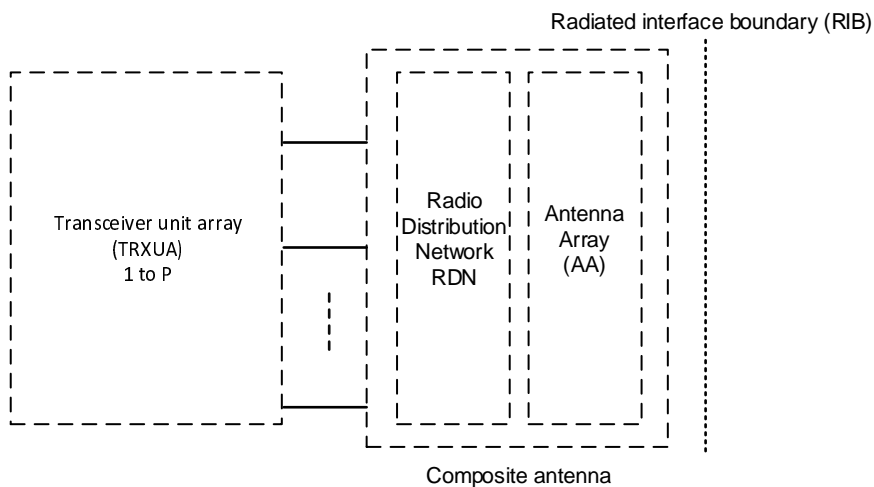

**Figure 4.2-2: General architecture of *BS type 1-O* and *BS type 2-O***

The transceiver unit array is part of the composite transceiver functionality generating modulated transmit signal structures and performing receiver combining and demodulation.

The transceiver unit array contains an implementation specific number of transmitter units and an implementation specific number of receiver units. Transmitter units and receiver units may be combined into transceiver units. The transmitter/receiver units have the ability to receive/send parallel independent modulated symbol streams.

The composite antenna contains a *radio distribution network* (RDN) and an antenna array. The RDN is a linear passive network that distributes the RF power between the *transceiver array boundary* and the antenna array, in an implementation specific way.

## 4.3 Base station classes

The requirements in this specification apply to Wide Area Base Stations, Medium Range Base Stations and Local Area Base Stations unless otherwise stated. The associated deployment scenarios and definitions of BS classes are exactly the same for BS with and without connectors.

BS classes for *BS type 1-H* are defined as indicated below:

- Wide Area Base Stations are characterised by requirements derived from Macro Cell scenarios with a BS to UE minimum coupling loss equal to 70 dB.
- Medium Range Base Stations are characterised by requirements derived from Micro Cell scenarios with a BS to UE minimum coupling loss equals to 53 dB.
- Local Area Base Stations are characterised by requirements derived from Pico Cell scenarios with a BS to UE minimum coupling loss equal to 45 dB.

BS classes for *BS type 1-O* and *BS type 2-O* are defined as indicated below:

- Wide Area Base Stations are characterised by requirements derived from Macro Cell scenarios with a BS to UE minimum distance along the ground equal to 35 m.
- Medium Range Base Stations are characterised by requirements derived from Micro Cell scenarios with a BS to UE minimum distance along the ground equal to 5 m.
- Local Area Base Stations are characterised by requirements derived from Pico Cell scenarios with a BS to UE minimum distance along the ground equal to 2 m.

For *BS type 1-H* and *1-O*, ATG BS class is defined as indicated below:

- ATG Base Stations are characterized by requirements derived from ATG scenarios with a ground BS to air UE with typical vertical altitude of around 10,000m and take-off/landing altitudes down to 3000m.
- Unless otherwise stated, ATG BS class would refer to Wide Area BS class, which is specified in clause 4.4.

The manufacturer shall declare the intended class of the BS under test.

## 4.4 Regional requirements

Some requirements in the present document may only apply in certain regions either as optional requirements, or set by local and regional regulation as mandatory requirements. It is normally not stated in the 3GPP specifications under what exact circumstances that the requirements apply, since this is defined by local or regional regulation.

Table 4.4-1 lists all requirements in the present specification that may be applied differently in different regions.

Table 4.4-1: List of regional requirements

Clause	Requirement	Comments
5	Operating bands	Some NR operating bands may be applied regionally.
6.3.1	OTA base station output power	Additional output power limits may be applied regionally.
6.7.2	OTA occupied bandwidth	The requirement may be applied regionally. There may also be regional requirements to declare the occupied bandwidth according to the definition in present specification.
6.7.4	OTA operating band unwanted emissions	Category A or Category B operating band unwanted emission limits may be applied regionally.
6.7.4.5.1.6.1	OTA operating band unwanted emissions Limits in FCC Title 47	The BS may have to comply with the applicable emission limits established by FCC Title 47, when deployed in regions where those limits are applied, and under the conditions declared by the manufacturer.
6.7.4.5.1.6.2	OTA operating band unwanted emissions Protection of DTT	The BS operating in Band n20 may have to comply with the additional requirements for protection of DTT, when deployed in certain regions.
6.7.4.5.1.6.3	Operating band unwanted emissions Additional requirements for n24	The BS operating in Band n24 may have to comply with the additional requirements when deployed in regions where FCC regulation applies.
6.7.5.2	General OTA transmitter spurious emissions	Category A or Category B spurious emission limits, as defined in ITU-R Recommendation SM.329 [5], may apply regionally. The emission limits for BS type 1-O specified as the <i>basic limit</i> + X (dB) are applicable, unless stated differently in regional regulation.
6.7.5.4	Additional OTA transmitter spurious emissions	These requirements may be applied for the protection of system operating in frequency ranges other than the BS operating band.
6.8.5.1	OTA transmitter intermodulation	Interfering signal positions that are partially or completely outside of any downlink <i>operating band</i> of the base station are not excluded from the requirement in Japan in Band n77, n78, n79.
6.8.5.2	Additional OTA transmitter intermodulation	For Band n79 operation in Japan, the BS shall comply with the additional requirements.
6.8.5.2	Additional OTA transmitter intermodulation	For Band n26 and n28 operation in Japan, the BS shall comply with the additional requirements when the narrowest channel bandwidth supported by the BS is 5MHz or wider.
7.7.5	OTA receiver spurious emissions	The emission limits for BS type 1-O specified as the <i>basic limit</i> + X (dB) are applicable, unless stated differently in regional regulation. Additional limits for <i>BS type 2-O</i> may apply regionally.

## 4.5 BS configurations

### 4.5.1 Transmit configurations

Unless otherwise stated, the radiated transmitter characteristics in clause 6 are specified at RIB, with a full complement of transceiver units for the configuration in normal operating conditions.

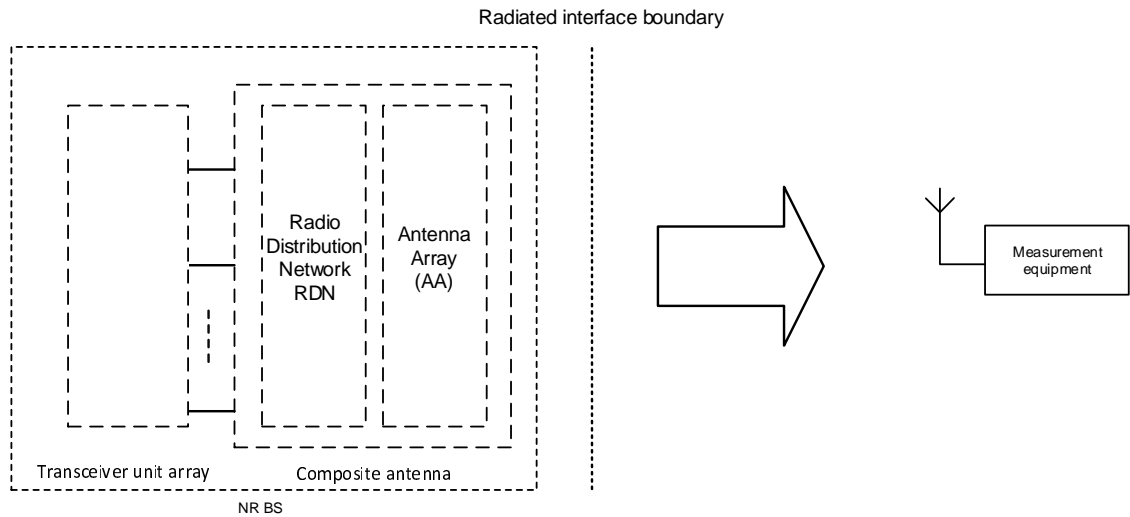

**Figure 4.5.1-1: Transmitter test interfaces**

Top view

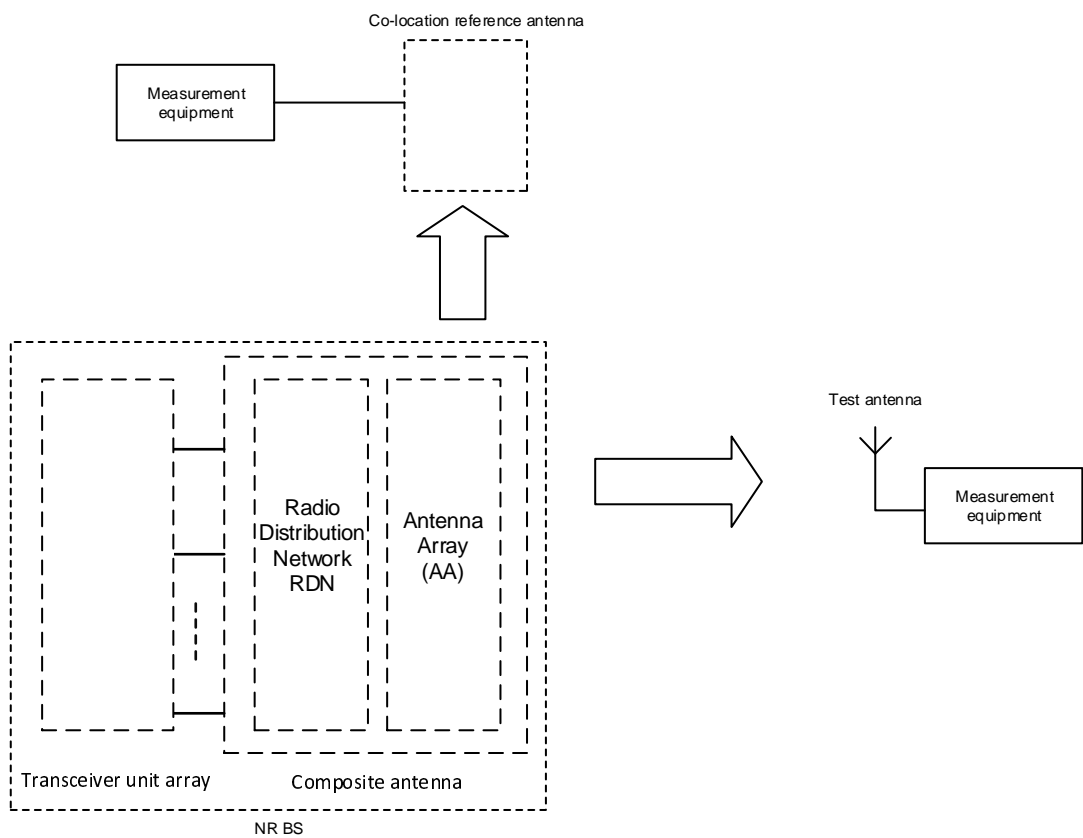

**Figure 4.5.1-2: Transmitter test interfaces for co-location concept**

4.5.2 Receive configurations

Unless otherwise stated, the radiated receiver characteristics in clause 7 are specified at RIB, with a full complement of transceiver units for the configuration in normal operating conditions.

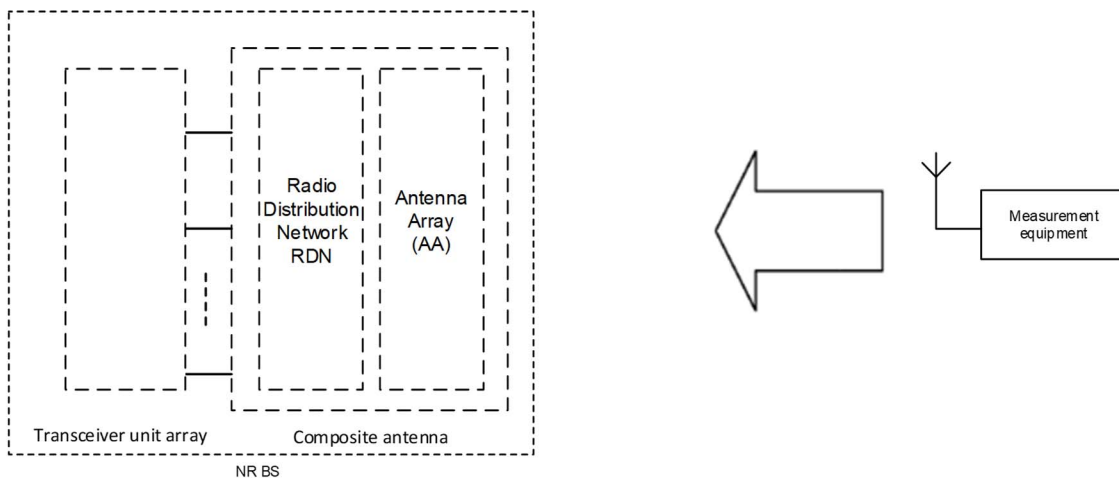

Figure 4.5.2-1: Receiver test interfaces

Top view

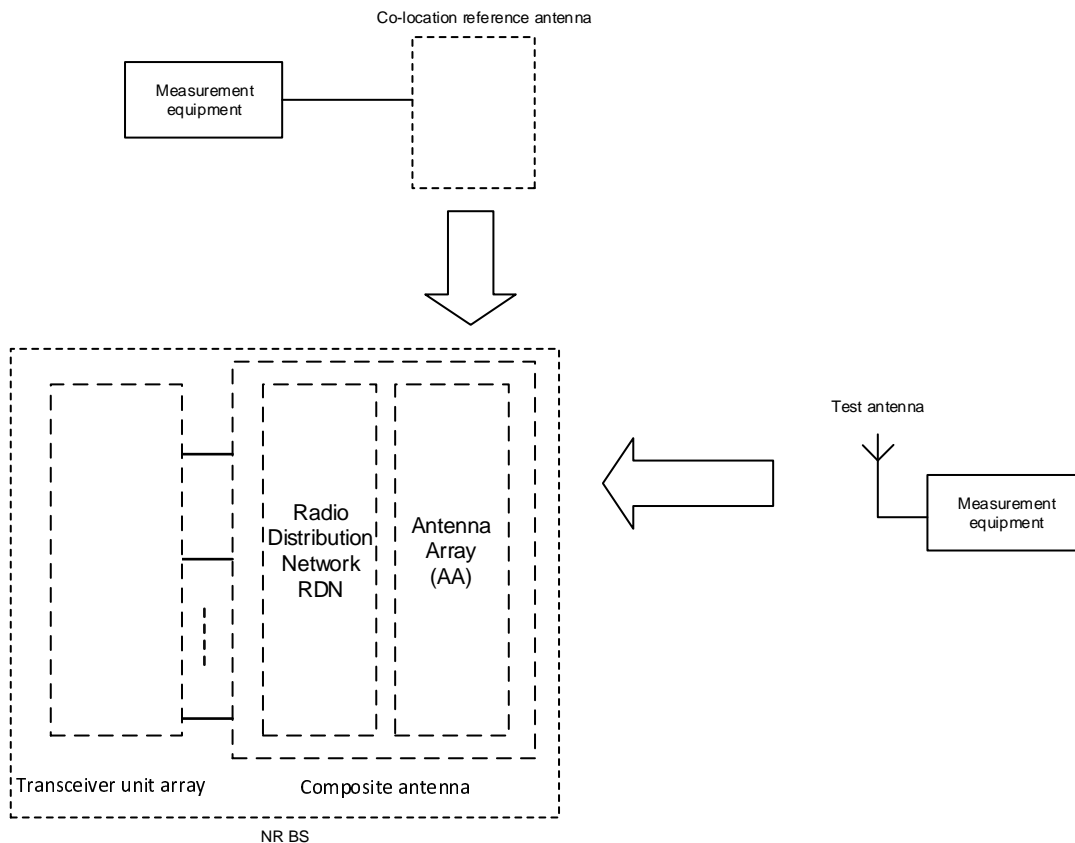

Figure 4.5.2-2: Receiver test interfaces for co-location concept

### 4.5.3 Power supply options

If the BS is supplied with a number of different power supply configurations, it may not be necessary to test RF parameters for each of the power supply options, provided that it can be demonstrated that the range of conditions over which the equipment is tested is at least as great as the range of conditions due to any of the power supply configurations.

#### 4.5.4 BS with integrated Iuant BS modem

Unless otherwise stated, for the tests in the present document, the integrated Iuant BS modem shall be switched OFF.

### 4.6 Manufacturer's declarations

The following BS manufacturer's declarations listed in table 4.6-1, when applicable to the BS under test, are required to be provided by the manufacturer for radiated requirements testing for *BS type 1-H*, *BS type 1-O* and *BS type 2-O*.

For the *BS type 1-H* declarations required for the conducted requirements testing, refer to TS 38.141-1 [3], clause 4.6.

**Table 4.6-1 Manufacturers declarations for *BS type 1-H*, *BS type 1-O* and *BS type 2-O* radiated test requirements**

Declaration identifier	Declaration	Description	Applicability (Note 1)		
			BS type 1-H (Note 2)	BS type 1-O	BS type 2-O
D.1	Coordinate system reference point	Location of coordinated system reference point in reference to an identifiable physical feature of the BS enclosure.	x	x	x
D.2	Coordinate system orientation	Orientation of the coordinate system in reference to an identifiable physical feature of the BS enclosure.	x	x	x
D.3	Beam identifier	<p>A unique title to identify a beam, e.g. a, b, c or 1, 2, 3. The vendor may declare any number of beams with unique identifiers. The minimum set to declare for conformance, corresponds to the beams at the reference beam direction with the highest intended EIRP, and covering the properties listed below:</p> <ol style="list-style-type: none"> <li>1) A beam with the narrowest intended <math>BeW_{\theta}</math> and narrowest intended <math>BeW_{\phi}</math> possible when narrowest intended <math>BeW_{\theta}</math> is used.</li> <li>2) A beam with the narrowest intended <math>BeW_{\phi}</math> and narrowest intended <math>BeW_{\theta}</math> possible when narrowest intended <math>BeW_{\phi}</math> is used.</li> <li>3) A beam with the widest intended <math>BeW_{\theta}</math> and widest intended <math>BeW_{\phi}</math> possible when widest intended <math>BeW_{\theta}</math> is used.</li> <li>4) A beam with the widest intended <math>BeW_{\phi}</math> and widest intended <math>BeW_{\theta}</math> possible when widest intended <math>BeW_{\phi}</math> is used.</li> <li>5) A beam which provides the highest intended EIRP of all possible beams.</li> </ol> <p>When selecting the above five beam widths for declaration, all beams that the BS is intended to produce shall be considered, including beams that during operation may be identified by any kind of cell or UE specific reference signals, with the exception of any type of beam that is created from a group of transmitters that are not all phase synchronised. (Note 3)</p>	x	x	x
D.4	<i>Operating bands and frequency ranges</i>	<p>List of NR <i>operating band(s)</i> supported by the BS and if applicable, frequency range(s) within the <i>operating band(s)</i> that the BS can operate in. Supported bands declared for every beam (D.3).</p> <p>(Note 4)</p>	c	x	x
D.5	BS requirements set	Declaration of one of the NR base station <i>requirements set</i> as defined for <i>BS type 1-H, BS type 1-O, or BS type 2-O</i> .	c	x	x
D.6	BS class	Declared as Wide Area BS, Medium Range BS, or Local Area BS.	c	x	x
D.7	BS channel band width and SCS support	BS supported SCS and channel bandwidth per supported SCS. Declared for each beam (D.3) and each <i>operating band</i> (D.4).	c	x	x
D.8	<i>OTA peak directions set reference beam direction pair</i>	The beam direction pair, describing the reference beam peak direction and the reference beam centre direction. Declared for every beam (D.3).	x	x	x
D.9	<i>OTA peak directions set</i>	The OTA peak directions set for each beam. Declared for every beam (D.3).	x	x	x



Declaration identifier	Declaration	Description	Applicability (Note 1)		
D.10	OTA peak directions set maximum steering direction(s)	The <i>beam direction pair(s)</i> corresponding to the following points: 1) The beam peak direction corresponding to the maximum steering from the reference beam centre direction in the positive $\Phi$ direction, while the $\theta$ value being the closest possible to the reference beam centre direction. 2) The beam peak direction corresponding to the maximum steering from the reference beam centre direction in the negative $\Phi$ direction, while the $\theta$ value being the closest possible to the reference beam centre direction. 3) The beam peak direction corresponding to the maximum steering from the reference beam centre direction in the positive $\theta$ direction, while the $\Phi$ value being the closest possible to the reference beam centre direction. 4) The beam peak direction corresponding to the maximum steering from the reference beam centre direction in the negative $\theta$ direction, while the $\Phi$ value being the closest possible to the reference beam centre direction. The maximum steering direction(s) may coincide with the reference beam centre direction. Declared for every beam (D.3).	x	x	x
D.11	Rated beam EIRP	The rated EIRP level per carrier ( $P_{\text{rated,c,EIRP}}$ ) at the <i>beam peak direction</i> associated with a particular <i>beam direction pair</i> for each of the declared maximum steering directions (D.10), as well as the reference <i>beam direction pair</i> (D.8). Declared for every beam (D.3). (Note 12, 14, 18, 20)	x	x	x
D.12	Beamwidth	The <i>beamwidth</i> for the reference <i>beam direction pair</i> and the four maximum steering directions. Declared for every beam (D.3).	x	x	x
D.13	Equivalent beams	List of beams which are declared to be equivalent. Equivalent beams imply that the beams are expected to have identical <i>OTA peak directions sets</i> and intended to have identical spatial properties at all steering directions within the <i>OTA peak directions set</i> when presented with identical signals. All declarations (D.4 – D.12) made for the beams are identical and the transmitter unit, RDN and antenna array responsible for generating the beam are of identical design.	x	x	x
D.14	Parallel beams	List of beams which have been declared equivalent (D.13) and can be generated in parallel using independent RF power resources. Independent power resources mean that the beams are transmitted from mutually exclusive transmitter units.	x	x	x
D.15	Number of carriers at maximum TRP	The number of carriers per operating band the BS is capable of generating at maximum TRP declared for every beam (D.3).	n/a	x	x
D.16	Operating bands with multi-band dependencies	List of <i>operating bands</i> which are generated using transceiver units supporting operation in multiple <i>operating bands</i> through common active RF components. Declared for each <i>operating band</i> for which multi-band transceiver is used.	c	x	n/a
D.17	Maximum radiated Base Station RF Bandwidth	Maximum <i>Base Station RF Bandwidth</i> in the <i>operating band</i> , declared for each supported operating band (D.4). (Note 15)	c	x	x

Declaration identifier	Declaration	Description	Applicability (Note 1)		
D.18	Maximum <i>Radio Bandwidth</i> of the <i>operating band</i> with multi-band dependencies	Largest <i>Radio Bandwidth</i> that can be supported by the <i>operating bands</i> with multi-band dependencies. Declared for each supported <i>operating band</i> which has multi-band dependencies (D.16).	c	x	n/a
D.19	Total RF bandwidth ( $BW_{tot}$ )	Total RF bandwidth $BW_{tot}$ of transmitter and receiver, declared per the band combinations (D.52).	c	x	x
D.20	CA-only operation	Declared of CA-only (with equal power spectral density among carriers) but not multiple carriers operation, declared per <i>operating band</i> (D.4) and per beam (D.3).	c	x	x
D.21	Maximum number of supported carriers per <i>operating band</i> in multi-band operations	Maximum number of supported carriers per supported <i>operating band</i> declared to have multi-band dependencies (D.16).	c	x	n/a
D.22	Contiguous or non-contiguous spectrum operation support	Ability of BS to support contiguous or non-contiguous (or both) frequency distribution of carriers when operating multi-carrier in an <i>operating band</i> .	c	x	x
D.23	OSDD identifier	A unique identifier for the OSDD.	x	x	n/a
D.24	OSDD operating band support	Operating band supported by the OSDD, declared for every OSDD (D.23). (Note 5)	x	x	n/a
D.25	OTA sensitivity supported BS channel bandwidth and SCS	The BS supported SCS and channel bandwidth per supported SCS by each OSDD.	x	x	n/a
D.26	Redirection of receiver target support	Ability to redirect the receiver target related to the OSDD.	x	x	n/a
D.27	Minimum EIS for FR1 ( $EIS_{minSENS}$ )	The minimum $EIS_{minSENS}$ requirement (i.e. maximum allowable EIS value) applicable to all sensitivity RoAoA per OSDD. Declared per NR supported channel BW for the OSDD (D.30). The lowest EIS value for all the declared OSDD's is called $minSENS$ , while its related range of angles of arrival is called <i>minSENS RoAoA</i> . (Note 6)	x	x	n/a
D.28	EIS REFSSENS for FR2 ( $EIS_{REFSENS\_50M}$ )	The $EIS_{REFSENS\_50M}$ level applicable in the OTA REFSSENS RoAoA, (used as a basis for the derivation of the FR2 $EIS_{REFSENS}$ for other channel bandwidths supported by BS). (Note 7)	n/a	n/a	x
D.29	Receiver target reference direction Sensitivity Range of Angle of Arrival	The sensitivity RoAoA associated with the receiver target reference direction (D.31) for each OSDD.	x	x	n/a
D.30	Receiver target redirection range	For each OSDD the associated union of all the sensitivity RoAoA achievable through redirecting the receiver target related to the OSDD. (Note 8)	x	x	n/a
D.31	Receiver target reference direction	For each OSDD an associated direction inside the receiver target redirection range (D.30). (Note 9)	x	x	n/a
D.32	Conformance test directions sensitivity RoAoA	For each OSDD that includes a receiver target redirection range, four sensitivity RoAoA comprising the conformance test directions (D.33).	x	x	n/a

Declaration identifier	Declaration	Description	Applicability (Note 1)		
D.33	Conformance test directions	<p>For each OSDD four conformance test directions.</p> <p>If the OSDD includes a receiver target redirection range the following four directions shall be declared:</p> <ol style="list-style-type: none"> <li>1) The direction determined by the maximum <math>\varphi</math> value achievable inside the receiver target redirection range, while <math>\theta</math> value being the closest possible to the receiver target reference direction.</li> <li>2) The direction determined by the minimum <math>\varphi</math> value achievable inside the receiver target redirection range, while <math>\theta</math> value being the closest possible to the receiver target reference direction.</li> <li>3) The direction determined by the maximum <math>\theta</math> value achievable inside the receiver target redirection range, while <math>\varphi</math> value being the closest possible to the receiver target reference direction.</li> <li>4) The direction determined by the minimum <math>\theta</math> value achievable inside the receiver target redirection range, while <math>\varphi</math> value being the closest possible to the receiver target reference direction.</li> </ol> <p>If an OSDD does not include a receiver target redirection range the following 4 directions shall be declared:</p> <ol style="list-style-type: none"> <li>1) The direction determined by the maximum <math>\varphi</math> value achievable inside the sensitivity RoAoA, while <math>\theta</math> value being the closest possible to the receiver target reference direction.</li> <li>2) The direction determined by the minimum <math>\varphi</math> value achievable inside the sensitivity RoAoA, while <math>\theta</math> value being the closest possible to the receiver target reference direction.</li> <li>3) The direction determined by the maximum <math>\theta</math> value achievable inside the sensitivity RoAoA, while <math>\varphi</math> value being the closest possible to the receiver target reference direction.</li> <li>4) The direction determined by the minimum <math>\theta</math> value achievable inside the sensitivity RoAoA, while <math>\varphi</math> value being the closest possible to the receiver target reference direction.</li> </ol>	x	x	n/a
D.34	OTA coverage range	<p>Declared as a single range of directions within which selected TX OTA requirements are intended to be met.</p> <p>(Note 10)</p>	x	x	x
D.35	OTA coverage range reference direction	<p>The direction describing the reference direction of the OTA coverage range (D.34).</p> <p>(Note 11)</p>	x	x	x

Declaration identifier	Declaration	Description	Applicability (Note 1)		
D.36	OTA coverage range maximum directions	The directions corresponding to the following points: 1) The direction determined by the maximum $\varphi$ value achievable inside the <i>OTA coverage range</i> , while $\theta$ value being the closest possible to the <i>OTA coverage range</i> reference direction. 2) The direction determined by the minimum $\varphi$ value achievable inside the <i>OTA coverage range</i> , while $\theta$ value being the closest possible to the <i>OTA coverage range</i> reference direction. 3) The direction determined by the maximum $\theta$ value achievable inside the <i>OTA coverage range</i> , while $\varphi$ value being the closest possible to the <i>OTA coverage range</i> reference direction. 4) The direction determined by the minimum $\theta$ value achievable inside the <i>OTA coverage range</i> , while $\varphi$ value being the closest possible to the <i>OTA coverage range</i> reference direction.	x	x	x
D.37	The rated carrier OTA BS power, $P_{\text{rated,c,TRP}}$	$P_{\text{rated,c,TRP}}$ is declared as TRP OTA power per carrier, declared per supported operating band. (Note 12, 14, 18, 20)	n/a	x	x
D.38	Rated transmitter TRP, $P_{\text{rated,t,TRP}}$	Rated total radiated output power. Declared per supported <i>operating band</i> . (Note 12,14, 18, 20)	n/a	x	x
D.39	CLTA placement for co-location test	The manufacturer shall declare the side of EUT where radiating elements are placed closest to the edge of EUT when applicable. The CLTA shall be placed at the EUT side where radiating elements are placed closest.	n/a	x	n/a
D.40	Spurious emission category	Declare the BS spurious emission category as either category A or B with respect to the limits for spurious emissions, as defined in Recommendation ITU-R SM.329 [5].	c	x	x
D.41	Additional operating band unwanted emissions	The manufacturer shall declare whether the BS under test is intended to operate in geographic areas where the additional operating band unwanted emission limits defined in clause 6.7.4 apply. (Note 16, Note 19)	c	x	x
D.42	Co-existence with other systems	The manufacturer shall declare whether the BS under test is intended to operate in geographic areas where one or more of the systems GSM850, GSM900, DCS1800, PCS1900, UTRA FDD, UTRA TDD, E-UTRA, PHS and/or NR operating in another operating band are deployed.	c	x	x
D.43	Co-location with other base stations	The manufacturer shall declare whether the BS under test is intended to operate co-located with Base Stations of one or more of the systems GSM850, GSM900, DCS1800, PCS1900, UTRA FDD, UTRA TDD, E-UTRA and/or NR operating in another operating band.	c	x	n/a
D.44	Single-band RIB or multi-band RIB	List of single-band RIB and/or multi-band RIB for the supported operating bands (D.4).	c	x	n/a
D.45	Single or multiple carrier	BS capability to operate with a single carrier (only) or multiple carriers. Declared per supported operating band, per RIB. (Note 17)	c	x	x
D.46	Maximum number of supported carriers per <i>operating band</i>	Maximum number of supported carriers. Declared per supported operating band, per RIB. (Note 15)	c	x	x
D.47	Total maximum number of supported carriers	Maximum number of supported carriers for all supported operating bands. Declared per RIB.	c	x	x

Declaration identifier	Declaration	Description	Applicability (Note 1)		
D.48	Other band combination multi-band restrictions	Declare any other limitation under simultaneous operation in the declared band combinations (D.16), which have any impact on the test configuration generation.	c	x	n/a
D.49	$N_{\text{cells}}$	Number corresponding to the minimum number of cells that can be transmitted by a BS in a particular <i>operating band</i> . Declared per <i>operating band</i> (D.4).	c	n/a	n/a
D.50	Maximum supported power difference between carriers	Maximum supported power difference between carriers in each supported <i>operating band</i> . Declared per <i>operating band</i> (D.4).	c	x	x
D.51	Maximum supported power difference between carriers is different <i>operating bands</i>	Maximum supported power difference between any two carriers in any two different supported <i>operating bands</i> . Declared per operating bands combination (D.52).	c	x	n/a
D.52	Operating band combination support	List of <i>operating bands</i> combinations supported by <i>single-band RIB(s)</i> and/or <i>multi-band RIB(s)</i> of the BS.	c	x	n/a
D.53	OTA REFSENS RoAoA	Range of angles of arrival associated with the OTA REFSENS.	n/a	x	x
D.54	OTA REFSENS receiver target reference direction	Reference direction inside the OTA REFSENS RoAoA (D.53).	n/a	x	x
D.55	OTA REFSENS conformance test directions	The following four OTA REFSENS conformance test directions shall be declared: 1) The direction determined by the maximum $\varphi$ value achievable inside the OTA REFSENS RoAoA, while $\theta$ value being the closest possible to the OTA REFSENS receiver target reference direction. 2) The direction determined by the minimum $\varphi$ value achievable inside the OTA REFSENS RoAoA, while $\theta$ value being the closest possible to the OTA REFSENS receiver target reference direction. 3) The direction determined by the maximum $\theta$ value achievable inside the OTA REFSENS RoAoA, while $\varphi$ value being the closest possible to the OTA REFSENS receiver target reference direction. 4) The direction determined by the minimum $\theta$ value achievable inside the OTA REFSENS RoAoA, while $\varphi$ value being the closest possible to the OTA REFSENS receiver target reference direction.	n/a	x	x
D.56	Supported frequency range of the NR <i>operating band</i>	List of supported frequency ranges representing <i>fractional bandwidths</i> (FBW) of <i>operating bands</i> with FBW larger than 6%.	x	x	x
D.57	Rated beam EIRP at lower end of the <i>fractional bandwidth</i> ( $P_{\text{rated,c,FBWlow}}$ )	The rated EIRP level per carrier at lower frequency range of the <i>fractional bandwidth</i> ( $P_{\text{rated,c,FBWlow}}$ ), at the <i>beam peak direction</i> associated with a particular <i>beam direction pair</i> for each of the declared maximum steering directions (D.10), as well as the reference <i>beam direction pair</i> (D.8). Declared per beam for all supported frequency ranges (D.56). (Note 12, 13, 14, 15, 18, 20)	x	x	x

Declaration identifier	Declaration	Description	Applicability (Note 1)		
D.58	Rated beam EIRP at higher frequency range of the <i>fractional bandwidth</i> ( $P_{\text{rated,c,FBWhigh}}$ )	The rated EIRP level per carrier at higher frequency range of the <i>fractional bandwidth</i> ( $P_{\text{rated,c,FBWhigh}}$ ), at the <i>beam peak direction</i> associated with a particular <i>beam direction pair</i> for each of the declared maximum steering directions (D.10), as well as the reference <i>beam direction pair</i> (D.8). Declared per beam for all supported frequency ranges in (D.56). (Note 12, 13, 14, 15, 18, 20)	x	x	x
D.59	Relation between supported maximum RF bandwidth, number of carriers and Rated maximum TRP	If the rated transmitter TRP and total number of supported carriers are not simultaneously supported, the manufacturer shall declare the following additional parameters: - The reduced number of supported carriers at the rated transmitter TRP; - The reduced total output power at the maximum number of supported carriers.	n/a	x	x
D.60	Inter-band CA	Declaration of operating band(s) combinations supporting inter-band CA. Declared per operating band combination (D.52).	c	x	x
D.61	Intra-band contiguous CA	Declaration of operating band(s) supporting intra-band contiguous CA. Declared per <i>operating band</i> with CA support.	c	x	x
D.62	Intra-band non-contiguous CA	Declaration of operating band(s) supporting intra-band non-contiguous CA. Declared per operating band with CA support.	c	x	x
D.63	Total maximum number of supported carriers in multi-band operation	Maximum number of supported carriers for all supported <i>operating bands</i> declared to have multi-band dependencies (D.16).	c	x	n/a
D.100	PUSCH mapping type	Declaration of the supported PUSCH mapping type for FR1 as specified in TS 38.211 [20], i.e., type A, type B or both.	c	x	n/a
D.101	PUSCH additional DM-RS positions	Declaration of the supported additional DM-RS position(s) for FR2, i.e., pos0, pos1, or both.	n/a	n/a	x
D.102	PUCCH format	Declaration of the supported PUCCH format(s) as specified in TS 38.211 [20], i.e., format 0, format 1, format 2, format 3, format 4.	c	x	x
D.103	PRACH format and SCS	Declaration of the supported PRACH format(s) as specified in TS 38.211 [20], i.e., format: 0, A1, A2, A3, B4, C0, C2.  Declaration of the supported SCS(s) per supported PRACH format with short sequence, as specified in TS 38.211 [20], i.e.:  - For <i>BS type 1-O</i> : 15 kHz, 30 kHz or both.  - For <i>BS type 2-O</i> : 60 kHz, 120 kHz or both.	c	x	x
D.104	Additional DM-RS for PUCCH format 3	Declaration of the supported additional DM-RS for PUCCH format 3: without additional DM-RS, with additional DM-RS or both.	c	x	x
D.105	Additional DM-RS for PUCCH format 4	Declaration of the supported additional DM-RS for PUCCH format 4: without additional DM-RS, with additional DM-RS or both.	c	x	x
D.106	PUSCH PT-RS	Declaration of PT-RS in PUSCH support: without PT-RS, with PT-RS or both.	n/a	n/a	x
D.107	PUCCH multi-slot	Declaration of multi-slot PUCCH support.	c	x	n/a
D.108	UL CA	For the highest supported SCS, declaration of the carrier combination with the largest aggregated bandwidth. If there is more than one combination, the carrier combination with the largest number of carriers shall be declared.	c	x	x

Declaration identifier	Declaration	Description	Applicability (Note 1)		
D.109	High speed train	Declaration of high speed train scenario support, i.e. HST support or no HST support	c	x	x
D.110	Maximum speed of high speed train for PUSCH	Declaration of supported maximum speed for high speed train scenario, i.e. 350 km/h or 500 km/h. This declaration is applicable to PUSCH for high speed train and UL timing adjustment only if BS declares to support high speed train in D.109.	c	x	n/a
D.111	PRACH format for high speed train	Declaration of supported PRACH format(s) for high speed train scenario, i.e. format 0 restricted set type A, format 0 restricted set type B, format A2, format B4, format C2. This declaration is applicable to PRACH for high speed train only if BS declares to support high speed train in D.109.	c	x	x
D.112	Interlaced formats	Declaration of support of interlaced PUSCH and PUCCH formats, i.e. interlaced format support or no interlaced format support.	c	x	n/a
D.113	PRACH format with $L_{RA} = 1151$ for 15 kHz SCS and $L_{RA} = 571$ for 30 kHz SCS	Declaration of the supported PRACH format(s) as specified in TS 38.211 [17], i.e., format: A2, B4, C2.  Declaration of the supported SCS(s) per supported PRACH format as specified in TS 38.211 [17], i.e., 15 kHz, 30 kHz or both.	c	x	n/a
D.114	CG-UCI	Declaration of support of GC-UCI multiplexed on PUSCH as specified in TS 38.211 [17].	c	x	n/a
D.115	2-step RA	Declaration of support of 2-step RA type.	c	x	x
D.116	PUSCH 256QAM	Declaration of PUSCH 256QAM support	c	x	x
D.117	Additional DM-RS for FR2 high speed train	Declaration of supported additional DM-RS position(s) for FR2 high speed train scenario for PUSCH and UL timing adjustment, i.e., pos0, pos1, pos2, or any combination	n/a	n/a	x
D.118	PUCCH sub-slot based repetition formats	Declaration of PUCCH sub-slot based repetition formats.	c	x	n/a
D.119	PUSCH TB over multi-slots	BS support TBoMS over physical consecutive UL slots	c	x	x
D.120	PUSCH TB over multi-slots	BS support TBoMS over physical non-consecutive UL slots	c	x	x
D.121	Supported SCS for TDD PUSCH DM-RS bundling and PUCCH DM-RS bundling	Declaration of supported SCS for TDD PUSCH DM-RS bundling and and PUCCH DM-RS bundling and, i.e. {15 kHz, 30 kHz, 60 kHz 120 kHz}	c	x	x
D.122	Supported FDD PUSCH DM-RS bundling and and PUCCH DM-RS bundling and	Declaration of supporting FDD PUSCH DM-RS bundling and PUCCH DM-RS bundling	c	x	x
D.123	MCS index table 3	Declaration of support MCS index table 3 as specified in TS 38.214 [18].	c	x	n/a
D.124	PUSCH repetition type A	Declaration of support PUSCH repetition type A	c	x	x
D.125	Air-to-ground scenario	Declaration of air-to-ground scenario support, i.e. ATG support or no ATG support	c	x	n/a
D.126	PRACH format and SCS for Multiple PRACH transmission	Declaration of the supported PRACH format(s) as specified in TS 38.211 [20] for Multiple PRACH transmission, i.e., format: A2, B4, C2. Declaration of the supported SCS(s) per supported PRACH format with short sequence for Multiple PRACH transmission, as specified in TS 38.211 [20], i.e.: - For BS type 2-O: 120 kHz.	c	n/a	x

Declaration identifier	Declaration	Description	Applicability (Note 1)		
D.127	PUSCH with enhanced DM-RS type	Declaration of support enhanced DM-RS type as specified in TS 38.211 [17].	x	x	n/a
D.128	PRACH format for HAPS scenario	Declaration of supported PRACH format(s) for HAPS scenario, i.e., format 1.	x	x	n/a
<p>NOTE 1: Manufacturer declarations applicable per BS <i>requirement set</i> were marked as "x". Manufacturer declarations not applicable per BS <i>requirement set</i> were marked as "n/a".</p> <p>NOTE 2: For BS type 1-H, the only radiated declarations are related to EIRP and EIS requirements. For BS type 1-H declarations required for the conducted requirements testing, refer to TS 38.141-1 [3]. For declarations marked as 'c', related conducted declarations in TS 38.141-1 [3] apply. When separately declared, they shall still use the same declaration identifier.</p> <p>NOTE 3: Depending on the capability of the system some of these beams may be the same. For those same beams, testing is not repeated.</p> <p>NOTE 4: These <i>operating bands</i> are related to their respective single-band RIBs.</p> <p>NOTE 5: As each identified OSDD has a declared minimum EIS value (D.27), multiple operating band can only be declared if they have the same minimum EIS declaration.</p> <p>NOTE 6: If the BS type 1-H or BS type 1-O is not capable of redirecting the receiver target related to the OSDD then there is only one RoAoA applicable to the OSDD.</p> <p>NOTE 7: Although EIS<sub>REFSENS_50M</sub> level is based on a reference measurement channel with BW<sub>Channel</sub> = 50 MHz, it does not imply that BS has to support 50 MHz channel bandwidth.</p> <p>NOTE 8: Not applicable for BS type 2-O.</p> <p>NOTE 9: For an OSDD without receiver target redirection range, this is a direction inside the sensitivity RoAoA.</p> <p>NOTE 10: <i>OTA coverage range</i> is used for conformance testing of such TX OTA requirements as occupied bandwidth, frequency error, TAE or EVM.</p> <p>NOTE 11: The <i>OTA coverage reference</i> direction may be the same as the Reference beam direction pair (D.8) but does not have to be.</p> <p>NOTE 12: If a BS type 2-O is capable of 64QAM DL operation but not capable of 256QAM DL operation, then up to two rated output power declarations may be made. One declaration is applicable when configured for 64QAM transmissions and the other declaration is applicable when not configured for 64QAM transmissions.</p> <p>NOTE 13: If D.57 and D.58 are declared for certain frequency range (D.56), there shall be no "Rated beam EIRP" declaration (D.11) for the <i>operating band</i> containing that particular frequency range.</p> <p>NOTE 14: If a BS is capable of 1024QAM DL operation then up to three rated output power declarations may be made. One declaration is applicable when configured for 1024QAM transmissions, a different declaration is applicable when configured 256QAM transmissions and the other declaration is applicable when configured neither for 256QAM nor 1024QAM transmissions.</p> <p>NOTE 15: Parameters for contiguous or non-contiguous spectrum operation in the operating band are assumed to be the same unless they are separately declared.</p> <p>NOTE 16: If BS is declared to support Band n20 (D.4), the manufacturer shall declare if the BS may operate in geographical areas allocated to broadcasting (DTT). Additionally, related declarations of the emission levels and maximum output power shall be declared.</p> <p>NOTE 17: In case of BS type 1-H, this declaration applies per <i>TAB connector</i>.</p> <p>NOTE 18: If a BS type 2-O is capable of 256QAM DL operation, then up to three rated output power declarations may be made. One declaration is applicable when configured for 256QAM transmissions, a different declaration is applicable when configured for 64QAM transmissions and the other declaration is applicable when not configured neither for 256QAM nor 64QAM transmissions.</p> <p>NOTE 19: If BS is declared to support Band n24 (D.4), the manufacturer shall declare if the BS may operate in geographical areas where FCC regulations apply. Additionally, related declarations of the emission levels and maximum output power shall be declared.</p> <p>NOTE 20: If a BS is capable of 256QAM DL operation but not capable of 1024QAM DL operation then up to two rated output power declarations may be made. One declaration is applicable when configured for 256QAM transmissions, and the other declaration is applicable when not configured for 256QAM transmissions</p>					

## 4.7 Test configurations

### 4.7.1 General

The test configurations shall be constructed using the methods defined below subject to the parameters declared by the manufacturer as listed in clause 4.6.

The applicable test models for generation of the carrier transmit test signal are defined in clause 4.9.2.

NOTE: If required, carriers are shifted to align with the channel raster.



## 4.7.2 Test signal configurations

### 4.7.2.1 Test signal used to build Test Configurations

The signal's *BS channel bandwidth* and subcarrier spacing used to build NR Test Configurations shall be selected according to tables 4.7.2.1-1 and 4.7.2.1-2.

**Table 4.7.2.1-1: Signal to be used to build NR TCs for BS type 1-H and BS type 1-O**

Operating band characteristics		$F_{DL\_high} - F_{DL\_low} < 100$ MHz	$F_{DL\_high} - F_{DL\_low} \geq 100$ MHz
TC signal characteristics	$BW_{channel}$	5 MHz (Note)	20 MHz (Note)
	Subcarrier spacing	Smallest supported subcarrier spacing declared per operating band (D.7)	
NOTE: If this <i>BS channel bandwidth</i> is not supported, the narrowest supported <i>BS channel bandwidth</i> declared per operating band (D.7) shall be used.			

**Table 4.7.2.1-2: Signal to be used to build NR TCs for BS type 2-O**

Operating band characteristics		$F_{DL\_high} - F_{DL\_low} \leq 3250$ MHz	$3250 < F_{DL\_high} - F_{DL\_low} \leq 14000$ MHz
TC signal characteristics	$BW_{channel}$	100 MHz (Note 1, Note 2)	400 MHz (Note 1, Note 2, Note 3)
	Subcarrier spacing	Smallest supported subcarrier spacing declared per operating band (D.7)	
NOTE 1: BS vendor can decide to test with 50 MHz <i>BS channel bandwidth</i> and smallest supported SCS declared per operating band (D.7) instead of 100 MHz <i>BS channel bandwidth</i> in certain regions, where spectrum allocation and regulation require testing with 50 MHz.			
NOTE 2: If this <i>BS channel bandwidth</i> is not supported, the narrowest supported <i>BS channel bandwidth</i> declared per operating band (D.7) shall be used.			
NOTE 3: For FR2-2 only NRTC1 and NRTC2 are applicable.			

### 4.7.2.2 NRTC1: Contiguous spectrum operation

The purpose of test configuration NRTC1 is to test all BS requirements excluding CA occupied bandwidth.

For NRTC1 used in receiver tests only the two outermost carriers within each supported operating band need to be generated by the test equipment.

#### 4.7.2.2.1 NRTC1 generation

NRTC1 shall be constructed on a per band basis using the following method:

- The *Base Station RF Bandwidth* of each supported operating band shall be the declared maximum radiated *Base Station RF Bandwidth* for contiguous operation (D.17).
- Select the carrier to be tested according to 4.7.2.1 and place it adjacent to the lower *Base Station RF Bandwidth edge*. Place same signal adjacent to the upper *Base Station RF Bandwidth edge*.
- For transmitter tests, select as many carriers (according to 4.7.2.1) that the beam supports within a band and that fit in the rest of the declared maximum *Base Station RF Bandwidth*. Place the carriers adjacent to each other starting from the upper *Base Station RF Bandwidth edge*. The nominal carrier spacing defined in TS 38.104 [2] clause 5.4.1 shall apply;

The test configuration should be constructed on a per band basis for all component carriers of the inter-band CA bands declared to be supported by the beam (D.60). All configured component carriers are transmitted simultaneously in the tests where the transmitter should be on.

#### 4.7.2.2.2 NRTC1 power allocation

Set the number of carriers to the number of carriers at maximum TRP (D.15).

For EIRP accuracy requirements set each beam to rated beam EIRP (D.11) for the tested *beam direction pair*.

For all other requirements set the power of each carrier to the same level so that the sum of the carrier powers equals the rated transmitter TRP  $P_{\text{rated,t,TRP}}$  (D.38).

For a beam declared to support CA-only operation (D.20), set the power spectral density of each carrier to the same level so that the sum of the carrier power equals the same value as above.

### 4.7.2.3 NRTC2: Contiguous CA occupied bandwidth

NRTC2 in this clause is used to test CA occupied bandwidth.

#### 4.7.2.3.1 NRTC2 generation

NRTC2 shall be constructed on a per band basis using the following method:

- Of all component carrier combinations supported by the beam, those which have smallest or largest sum of channel bandwidths of component carrier, shall be tested. Of all component carrier combinations which have smallest or largest sum of channel bandwidth of component carriers supported by the BS, only one combination having largest sum and one combination having smallest sum shall be tested irrespective of the number of component carriers.
- Of all component carrier combinations which have same sum of channel bandwidths of component carrier, select those with the narrowest carrier with the smallest supported subcarrier spacing declared per *operating band* (D.7) at the lower *Base Station RF Bandwidth edge*.
- Of the combinations selected in the previous step, select one with the narrowest carrier with the smallest supported subcarrier spacing declared per *operating band* (D.7) at the upper *Base Station RF Bandwidth edge*.
- If there are multiple combinations fulfilling previous steps, select the one with the smallest number of component carrier.
- If there are multiple combinations fulfilling previous steps, select the one with the widest carrier with the smallest supported subcarrier spacing declared per *operating band* (D.7) being adjacent to the lowest carrier.
- If there are multiple combinations fulfilling previous steps, select the one with the widest carrier with the smallest supported subcarrier spacing declared per *operating band* (D.7) being adjacent to the highest carrier.
- If there are multiple combinations fulfilling previous steps, select the one with the widest carrier with the smallest supported subcarrier spacing declared per *operating band* (D.7) being adjacent to the carrier which has been selected in the previous step.
- If there are multiple combinations fulfilling previous steps, repeat the previous step until there is only one combination left.
- The nominal channel spacing defined in TS 38.104 [2] clause 5.4.1 shall apply.

#### 4.7.2.3.2 NRTC2 power allocation

Set the number of carriers to the number of carriers at maximum TRP (D.15).

For EIRP accuracy requirements set each beam to rated beam EIRP (D.11) for the tested *beam direction pair*.

Set the power spectral density of each carrier to the same level so that the sum of the carrier powers equals the rated transmitter TRP  $P_{\text{rated,t,TRP}}$  (D.38).

### 4.7.2.4 NRTC3: Non-contiguous spectrum operation

The purpose of NRTC3 is to test NR multicarrier non-contiguous aspects.

For NRTC3 used in receiver tests, outermost carriers for each sub-block need to be generated by the test equipment; other supported carriers are optional to be generated.

#### 4.7.2.4.1 NRTC3 generation

NRTC3 is constructed on a per band basis using the following method:

- The *Base Station RF Bandwidth* of each supported operating band shall be the declared maximum radiated *Base Station RF Bandwidth* for non-contiguous operation (D.17). The *Base Station RF Bandwidth* consists of one sub-block gap and two sub-blocks located at the edges of the declared maximum radiated *Base Station RF Bandwidth* for non-contiguous operation (D.17).
- Select the carrier to be tested according to 4.7.2.1. Place it adjacent to the upper *Base Station RF Bandwidth edge* and another similar carrier adjacent to the lower *Base Station RF Bandwidth edge*.
- For single-band operation receiver tests, if the remaining gap is at least 15 MHz (or 60 MHz if channel bandwidth of the carrier to be tested is 20 MHz) for FR1 or 150 MHz for FR2 plus two times the *channel bandwidth* used in the previous step and the beam supports at least 4 carriers, place a NR carrier of this *channel bandwidth* adjacent to each already placed carrier for each sub-block. The nominal channel spacing defined in TS 38.104 [2] clause 5.4.1 shall apply.
- The sub-block edges adjacent to the sub-block gap shall be determined using the specified  $F_{\text{offset\_high}}$  and  $F_{\text{offset\_low}}$  for the carriers adjacent to the sub-block gap.

#### 4.7.2.4.2 NRTC3 power allocation

Set the number of carriers to the number of carriers at maximum TRP (D.15).

For EIRP accuracy requirements set each beam to rated beam EIRP (D.11) for the tested *beam direction pair*.

For all other requirements set the power of each carrier to the same level so that the sum of the carrier powers equals the rated transmitter TRP  $P_{\text{rated, t,TRP}}$  (D.38).

#### 4.7.2.5 NRTC4: Multi-band test configuration for full carrier allocation

The purpose of NRTC4 is to test beams which have been generated using transceiver units supporting operation in multiple operating bands through common active RF components, considering maximum supported number of carriers.

##### 4.7.2.5.1 NRTC4 generation

NRTC4 is based on re-using the existing test configuration applicable per band on beams generated using Multi-band transceiver units and hence have declared multi-band dependencies (D.16). It is constructed using the following method:

- The *Base Station RF Bandwidth* of each supported operating band shall be the declared maximum radiated *Base Station RF Bandwidth* (D.17).
- The number of carriers of each supported operating band shall be the declared maximum number of supported carriers per *operating band* in multi-band operation (D.21). Carriers shall be selected according to 4.7.2.1 and shall first be placed at the outermost edges of the declared maximum radiated *Radio Bandwidth* (D.18). Additional carriers shall next be placed at the edges of *Base Station RF Bandwidth*, if possible.
- The allocated *Base Station RF Bandwidth* of the outermost bands shall be located at the outermost edges of the declared maximum radiated *Radio Bandwidth* (D.18).
- Each concerned band shall be considered as an independent band and the carrier placement in each band shall be according to NRTC1 where the declared parameters for multi-band operation shall apply. The mirror image of the single band test configuration shall be used in the highest band being tested for the beam.
- If an operating band with multi-band dependencies supports three carriers only, two carriers shall be placed in one band according to the relevant test configuration while the remaining carrier shall be placed at the edge of the maximum *Radio Bandwidth* in the other band.
- If the sum of the maximum *base station RF bandwidths* of each of the supported operating bands is greater than the declared *total RF bandwidth*  $BW_{\text{tot}}$  (D.19) of transmitter and receiver for the declared band combinations of the BS, then repeat the steps above for test configurations where the *Base Station RF Bandwidth* of one of the operating band shall be reduced so that the declared *total RF bandwidth* is not exceeded and vice versa.

- If the sum of the maximum number of supported carriers per *operating band* in multi-band operation (D.21) is larger than the declared total maximum number of supported carriers in multi-band operation (D.63), repeat the steps above for test configurations where in each test configuration the number of carriers of one of the operating band shall be reduced so that the total number of supported carriers is not exceeded and vice versa.

#### 4.7.2.5.2 NRTC4 power allocation

Set the number of carriers to the total maximum number of supported carriers in multi-band operation (D.63).

For EIRP accuracy requirements set each beam to rated beam EIRP (D.11) for the tested *beam direction pair*.

For all other requirements set the power of each carrier to the same level so that the sum of the carrier powers equals the rated transmitter TRP  $P_{\text{rated, t, TRP}}$  (D.38).

If the allocated number of carriers in an operating band exceeds the declared number of carriers at maximum TRP in an operating band (D.15) the carriers should if possible be allocated to a different operating band.

#### 4.7.2.6 NRTC5: Multi-band test configuration with high PSD per carrier

The purpose of NRTC5 is to test multi-band operation aspects considering higher PSD cases with reduced number of carriers and non-contiguous operation (if supported) in multi-band mode.

##### 4.7.2.6.1 NRTC5 generation

NRTC5 is based on re-using the existing test configuration applicable for operating bands using multi-band transceiver units and hence have declared multi-band dependencies (D.16). It is constructed using the following method:

- The *Base Station RF Bandwidth* of each supported operating band shall be the declared maximum radiated *Base Station RF Bandwidth* (D.17).
- The allocated *Radio Bandwidth* of the outermost bands shall be located at the outermost edges of the declared maximum *Radio Bandwidth* of the operating band with multi-band dependencies (D.18).
- The maximum number of carriers is limited to two per band. Carriers shall be selected according to 4.7.2.1 and shall be placed at the outermost edges of the declared maximum *Radio Bandwidth* of the operating band with multi-band dependencies (D.18).
- Each concerned band shall be considered as an independent band and the carrier placement in each band shall be according to NRTC3, where the declared parameters for multi-band operation shall apply. Narrowest supported *BS channel bandwidth* with the smallest subcarrier spacing declared per *operating band* (D.7) shall be used in the test configuration.
- If an *operating band* with multi-band dependencies supports three carriers only, two carriers shall be placed in one band according to the relevant test configuration while the remaining carrier shall be placed at the edge of the maximum *Radio Bandwidth* in the other band.
- If the sum of the maximum *base station RF bandwidths* of each of the supported *operating bands* is greater than the declared *total RF bandwidth*  $BW_{\text{tot}}$  (D.19) of transmitter and receiver for the declared band combinations of the BS, then repeat the steps above for test configurations where the *Base Station RF Bandwidth* of one of the *operating band* shall be reduced so that the declared *total RF bandwidth*  $BW_{\text{tot}}$  of the *operating band* with multi-band dependencies (D.18) is not exceeded and vice versa.

##### 4.7.2.6.2 NRTC5 power allocation

Set the number of carriers to the total maximum number of supported carriers in multi-band operation (D.63).

For EIRP accuracy requirements set each beam to rated beam EIRP (D.11) for the tested *beam direction pair*.

For all other requirements set the power of each carrier to the same level so that the sum of the carrier powers equals the rated transmitter TRP  $P_{\text{rated, t, TRP}}$  (D.38).

If the sum of the TRP for all carriers in an operating band(s) exceeds the sum of the rated carrier TRP output power  $P_{\text{rated, c, TRP}}$  (D.37) for the number of carriers at maximum TRP (D.15) in multi-band operation, the exceeded part shall, if

possible, be reallocated into the other band(s). If the TRP allocated for a carrier exceeds the declared rated carrier OTA BS power,  $P_{\text{rated,c,TRP}}$ , the exceeded power shall, if possible, be reallocated into the other carriers.

## 4.8 Applicability of requirements

### 4.8.1 Requirement set applicability

In table 4.8.1-1, the requirement applicability for each requirement set is defined. For each requirement, the applicable requirement clause in the specification is identified. Requirements not included in a requirement set is marked not applicable (NA).

**Table 4.8.1-1: Requirement set applicability**

Requirement	Requirement set		
	BS type 1-H	BS type 1-O	BS type 2-O
Radiated transmit power	6.2	6.2	6.2
OTA base station output power	NA	6.3	6.3
OTA output power dynamics		6.4	6.4
OTA transmit ON/OFF power		6.5	6.5
OTA transmitted signal quality		6.6	6.6
OTA occupied bandwidth		6.7.2	6.7.2
OTA ACLR		6.7.3	6.7.3
OTA out-of-band emission		6.7.4	6.7.4
OTA transmitter spurious emission		6.7.5	6.7.5
OTA transmitter intermodulation		6.8	NA
OTA sensitivity		7.2	7.2
OTA reference sensitivity level	NA	7.3	7.3
OTA dynamic range		7.4	NA
OTA in-band selectivity and blocking		7.5	7.5
OTA out-of-band blocking		7.6	7.6
OTA receiver spurious emission		7.7	7.7
OTA receiver intermodulation		7.8	7.8
OTA in-channel selectivity		7.9	7.9
Radiated performance requirements		8	8

### 4.8.2 Applicability of test configurations for *single-band RIB*

The applicable test configurations are specified in the tables below for each the supported RF configuration, which shall be declared according to clause 4.6. The generation and power allocation for each test configuration is defined in clause 4.7. This clause contains the test configurations for *single-band RIB*.

For a BS declared to be capable of single carrier operation only, a single carrier (SC) shall be used for testing.

For a *single-band RIB* declared to support multi-carrier and/or CA operation in contiguous spectrum operation, the test configurations in the second column of table 4.8.2-1 shall be used for testing.

For a *single-band RIB* declared to support multi-carrier and/or CA operation in contiguous and non-contiguous spectrum and where the parameters in the manufacturer's declaration according to clause 4.6 are identical for contiguous (C) and non-contiguous (NC) spectrum operation, the test configurations in the third column of table 4.8.2-1 shall be used for testing.

For a *single-band RIB* declared to support multi-carrier and/or CA in contiguous and non-contiguous spectrum and where the parameters in the manufacture's declaration according to clause 4.6 are not identical for contiguous and non-contiguous spectrum operation, the test configurations in the fourth column of table 4.8.2-1 shall be used for testing.

Unless otherwise stated, single carrier configuration (SC) tests shall be performed using signal with narrowest supported *BS channel bandwidth* with the smallest supported subcarrier spacing declared per *operating band* (D.7).

Table 4.8.2-1: Test configurations for a *single-band RIB*

BS test case	Contiguous spectrum capable BS	C and NC capable BS with identical parameters	C and NC capable BS with different parameters
Radiated transmit power	NRTC1	NRTC1	NRTC1, NRTC3
OTA base station maximum output power	NRTC1	NRTC1	NRTC1, NRTC3
OTA RE Power control dynamic range	Tested with Error Vector Magnitude	Tested with Error Vector Magnitude	Tested with Error Vector Magnitude
OTA total power dynamic range	SC	SC	SC
OTA transmit ON/OFF power (only applied for NR TDD BS)	NRTC1	NRTC1	NRTC1, NRTC3
OTA frequency error	Tested with Error Vector Magnitude	Tested with Error Vector Magnitude	Tested with Error Vector Magnitude
OTA error Vector Magnitude	NRTC1	NRTC1	NRTC1, NRTC3
OTA time alignment error	NRTC1	NRTC1	NRTC1, NRTC3
OTA Occupied bandwidth	SC, NRTC2 (Note 1)	SC, NRTC2 (Note 1)	SC, NRTC2 (Note 1)
OTA ACLR	NRTC1	NRTC1, NRTC3	NRTC1, NRTC3
OTA CA CLR	-	NRTC3	NRTC3
OTA operating band unwanted emissions	NRTC1, SC (Note 2)	NRTC1, NRTC3, SC (Note 2)	NRTC1, NRTC3, SC (Note 2)
OTA transmitter spurious emissions	NRTC1	NRTC3	NRTC1, NRTC3
OTA transmitter intermodulation	NRTC1	NRTC1, NRTC3	NRTC1, NRTC3
OTA sensitivity	SC	SC	SC
OTA reference sensitivity level	SC	SC	SC
OTA dynamic range	SC	SC	SC
OTA adjacent channel selectivity	NRTC1	NRTC3	NRTC1, NRTC3
In-band blocking	NRTC1	NRTC3	NRTC1, NRTC3
OTA out-of-band blocking	NRTC1	NRTC3	NRTC1, NRTC3
OTA receiver spurious emissions	NRTC1	NRTC3	NRTC1, NRTC3
OTA receiver intermodulation	NRTC1	NRTC3	NRTC1, NRTC3
OTA in-channel selectivity	SC	SC	SC
Note 1: NRTC2 is only applicable when contiguous CA is supported.			
Note 2: OBUE SC shall be tested using the widest supported channel bandwidth and the highest supported subcarrier spacing.			

### 4.8.3 Applicability of test configurations for *multi-band RIB*

For a *multi-band RIB*, the test configuration in table 4.8.3-1 shall be used for testing.

Unless otherwise stated, single carrier configuration (SC) tests shall be performed using signal with narrowest supported *BS channel bandwidth* with the smallest supported subcarrier spacing declared per *operating band* (D.7).

NOTE: The applicability of test configurations in table 4.8.3-1 are not applicable to *BS type 2-O*.

**Table 4.8.3-1: Test configuration for a multi-band RIB**

BS test case	Test configuration
Radiated transmit power	NRTC1/3 (Note 1), NRTC4
OTA base station maximum output power	NRTC1/3 (Note 1), NRTC4
OTA RE power control dynamic range	Tested with Error Vector Magnitude
OTA total power dynamic range	SC
OTA transmit ON/OFF power (only applied for NR TDD BS)	NRTC4
OTA frequency error	Tested with Error Vector Magnitude
OTA Error Vector Magnitude	NRTC1/3 (Note 1), NRTC4
OTA time alignment error	NRTC1/3 (Note 1), NRTC5 (Note 2)
OTA occupied bandwidth	SC, NRTC2 (Note 3)
OTA ACLR	NRTC1/3 (Note 1), NRTC5 (Note 4)
OTA CA CLR	NRTC3 (Note 1), NRTC5 (Note 4)
OTA operating band unwanted emissions	NRTC1/3 (Note 1), NRTC5, SC (Note 5)
OTA transmitter spurious emissions	NRTC1/3 (Note 1), NRTC5
OTA transmitter intermodulation	NRTC1/3 (Note 1)
OTA sensitivity	SC
OTA reference sensitivity level	SC
OTA dynamic range	SC
OTA adjacent channel selectivity	NRTC5
In-band blocking	NRTC5
OTA out-of-band blocking	NRTC5
OTA receiver spurious emissions	NRTC1/3 (Note 1), NRTC5
OTA receiver intermodulation	NRTC5
OTA in-channel selectivity	SC
Note 1: NRTC1 and/or NRTC3 shall be applied in each supported operating band. Note 2: NRTC5 is only applicable when inter-band CA is supported. Note 3: NRTC2 is only applicable when contiguous CA is supported. Note 4: NRTC5 may be applied for Inter RF Bandwidth gap only. Note 5: OBUE SC shall be tested using the widest supported channel bandwidth and the highest supported sub-carrier spacing.	

#### 4.8.4 Additional conformance

For a BS type 1-H additionally conforming to TS 37.145-2 [30], conformance to some of the RF requirements in the present document can be demonstrated through the corresponding requirements in TS 37.145-2 [30] as listed in Table 4.8.4-1.

**Table 4.8.4-1: Alternative RF test requirements for a BS additionally conforming to TS 37.145-2 [30] for BS type 1-H**

RF requirement	Clause in the present document	Alternative clause in TS 37.145-2 [30]
Radiated transmit power	6.2.5	6.2.5
OTA sensitivity	7.2.5.2	7.2.5.5

For a BS type 1-O additionally conforming to TS 37.145-2 [30], conformance to some of the RF requirements in the present document can be demonstrated through the corresponding requirements in TS 37.145-2 [30] as listed in Table 4.8.4-2.

**Table 4.8.4-2: Alternative RF test requirements for a BS additionally conforming to TS 37.145-2 [30] for BS type 1-O**

RF requirement	Clause in the present document	Alternative clause in TS 37.145-2 [30]
Radiated transmit power	6.2.5	6.2.5
OTA base station output power	6.3.5.1	6.3.2.5
OTA transmit ON/OFF power	6.5	6.5
OTA Unwanted emissions		
OTA transmitter spurious emission	6.7.5.2.5, 6.7.5.3.5, 6.7.5.4.5, 6.7.5.5.5	6.7.6.2.5, 6.7.6.3.5, 6.7.6.4.5, 6.7.6.5.5
OTA Operating band unwanted emissions	6.7.4.5.1	6.7.5.5 (except for 6.7.5.5.5)
OTA Transmitter intermodulation	6.8.5	6.8.5.1
OTA sensitivity	7.2.5.2	7.2.5.5
OTA reference sensitivity level	7.3.5.2	7.3.5.4
OTA Narrowband blocking	7.5.2.5.2	7.5.5.1.2
OTA Blocking	7.5.2.5.2	7.5.5.1.1
OTA Out-of-band blocking	7.6.5.1.1	7.6.2.5.1
Co-location with other base stations	7.6.5.1.2	7.6.3.5.1
OTA Receiver spurious emissions	7.7.5.1	7.7.5
OTA Intermodulation	7.8.5.1	7.8.5.1.1
OTA Narrowband intermodulation	7.8.5.1	7.8.5.1.2

## 4.9 RF channels and test models

### 4.9.1 RF channels

For the single carrier testing many tests in this TS are performed with appropriate frequencies in the bottom, middle and top channels of the supported frequency range of the BS. These are denoted as RF channels B (bottom), M (middle) and T (top).

Unless otherwise stated, the test shall be performed with a single carrier at each of the RF channels B, M and T.

Many tests in this TS are performed with the maximum *Base Station RF Bandwidth* located at the bottom, middle and top of the supported frequency range in the operating band. These are denoted as  $B_{RFBW}$  (bottom),  $M_{RFBW}$  (middle) and  $T_{RFBW}$  (top).

Unless otherwise stated, the test shall be performed at  $B_{RFBW}$ ,  $M_{RFBW}$  and  $T_{RFBW}$  defined as following:

- $B_{RFBW}$ : maximum *Base Station RF Bandwidth* located at the bottom of the supported frequency range in the operating band.
- $M_{RFBW}$ : maximum *Base Station RF Bandwidth* located in the middle of the supported frequency range in the operating band.
- $T_{RFBW}$ : maximum *Base Station RF Bandwidth* located at the top of the supported frequency range in the operating band.

For a BS capable of multi-band operation and capable of dual-band operation, unless otherwise stated, the test shall be performed at  $B_{RFBW\_T_{RFBW}}$  and  $B'_{RFBW\_T_{RFBW}}$  defined as following:

- $B_{RFBW\_T_{RFBW}}$ : the *Base Station RF Bandwidths* located at the bottom of the supported frequency range in the lower operating band and at the highest possible simultaneous frequency position, within the maximum *Radio Bandwidth*, in the upper operating band.
- $B'_{RFBW\_T_{RFBW}}$ : the *Base Station RF Bandwidths* located at the top of the supported frequency range in the upper operating band and at the lowest possible simultaneous frequency position, within the maximum *Radio Bandwidth*, in the lower operating band.



NOTE:  $B_{\text{RFBW\_T'RFBW}} = B'_{\text{RFBW\_T'RFBW}} = B_{\text{RFBW\_T'RFBW}}$  when the declared maximum *Radio Bandwidth* (see clause 4.6) spans both operating bands.  $B_{\text{RFBW\_T'RFBW}}$  means the *Base Station RF Bandwidths* are located at the bottom of the supported frequency range in the lower operating band and at the top of the supported frequency range in the upper operating band.

Occupied bandwidth test in this TS are performed with the *aggregated BS channel bandwidth* and sub-block bandwidths located at the bottom, middle and top of the supported frequency range in the operating band. These are denoted as  $B_{\text{BW Channel CA}}$  (bottom),  $M_{\text{BW Channel CA}}$  (middle) and  $T_{\text{BW Channel CA}}$  (top) for contiguous spectrum operation.

Unless otherwise stated, the test for contiguous spectrum operation shall be performed at  $B_{\text{BW Channel CA}}$ ,  $M_{\text{BW Channel CA}}$  and  $T_{\text{BW Channel CA}}$  defined as following:

- $B_{\text{BW Channel CA}}$ : *aggregated BS channel bandwidth* located at the bottom of the supported frequency range in each operating band;
- $M_{\text{BW Channel CA}}$ : *aggregated BS channel bandwidth* located close in the middle of the supported frequency range in each operating band;
- $T_{\text{BW Channel CA}}$ : *aggregated BS channel bandwidth* located at the top of the supported frequency range in each operating band.

When a test is performed by a test laboratory, the position of B, M and T for single carrier,  $B_{\text{RFBW}}$ ,  $M_{\text{RFBW}}$  and  $T_{\text{RFBW}}$  for single band operation,  $B_{\text{BW Channel CA}}$ ,  $M_{\text{BW Channel CA}}$  and  $T_{\text{BW Channel CA}}$  for contiguous spectrum operation in the operating band, the position of  $B_{\text{RFBW\_T'RFBW}}$  and  $B'_{\text{RFBW\_T'RFBW}}$  in the supported operating band combinations shall be specified by the laboratory. The laboratory may consult with operators, the manufacturer or other bodies.

## 4.9.2 Test models

### 4.9.2.1 General

The following clauses will describe the NR test models needed for *BS type 2-O*. Note the NR FR1 test models described in TS 38.141-1 [3] are also applicable for *BS type 1-O* conformance testing.

### 4.9.2.2 NR FR2 test models

The set-up of physical channels for transmitter tests shall be according to one of the NR test models (NR- FR2-TM) below. A reference to the applicable test model is made within each test.

The following general parameters are used by all NR test models:

- For FR2-1, duration is 2 radio frames for TDD (20 ms). For FR2-2, duration is twice of 80 slots in time length (160 slots time length).
- The slots are numbered 0 to  $10 \times 2^\mu - 1$  where  $\mu$  is the numerology corresponding to the subcarrier spacing
- $N_{\text{RB}}$  is the maximum transmission bandwidth configuration seen in table 5.3.2-2 and table 5.3.2-3 in TS 38.104 [2].
- Normal CP
- Virtual resource blocks of localized type

For NR FR2 TDD, test models are derived based on the uplink/downlink configuration as shown in the table 4.9.2.2-1 using information element *TDD-UL-DL-ConfigCommon* as defined in TS 38.331 [22].

**Table 4.9.2.2-1: Configurations of TDD for BS type 2-O test models**

Field name	Value			
referenceSubcarrierSpacing (kHz)	60	120	480	960
Periodicity (ms) for dl-UL-TransmissionPeriodicity	1.25	1.25	1.25	1.25
nrofDownlinkSlots	3	7	29	59
nrofDownlinkSymbols	10	6	10	6
nrofUplinkSlots	1	2	9	18
nrofUplinkSymbols	2	4	2	4

Common physical channel parameters for all FR2 test models are specified in the following tables: table 4.9.2.2-2 for PDCCH, table 4.9.2.2-3 and table 4.9.2.2-4 for PDSCH. Specific physical channel parameters for FR2 test models are described in clauses 4.9.2.2.1 to 4.9.2.2.3.

**Table 4.9.2.2-2: Common physical channel parameters for BS type 2-O PDCCH**

Parameter	Value
# of symbols used for control channel	2
Starting symbol number for control channel	0
# of CCEs allocated to PDCCH	1
Starting RB location for PDCCH	0
# of available REGs	6
Aggregation level	1
# of RBs not allocated for PDCCH in each symbol	$N_{RB} - 3$
Ratio of PDCCH EPRE to DM-RS EPRE	0 dB
Boosting level of control channel	0 dB

**Table 4.9.2.2-3: Common physical channel parameters for BS type 2-O PDSCH**

Parameter	Value
mapping type	PDSCH mapping type A
<i>dmrs-TypeA-Position</i> for the first DM-RS symbol	'pos2'
<i>dmrs-AdditionalPosition</i> for additional DM-RS symbol(s)	0
<i>dmrs-Type</i> for comb pattern	Configuration type 1
maxLength	1
Ratio of PDSCH EPRE to DM-RS EPRE	0 dB
PTRS configuration and density	$L_{PT-RS} = 4$ $K_{PT-RS} = 2$ $k_{ref}^{RE} = 00$
Ratio of PT-RS EPRE to DM-RS EPRE	0 dB

**Table 4.9.2.2-4: Common physical channel parameters for PDSCH by RNTI for BS type 2-O test models**

Parameter	Value
PDSCH $n_{RNTI} = 0$	
Starting symbol	0
Ratio of PDSCH EPRE to PDCCH EPRE	0 dB
PDSCH $n_{RNTI} = 2$	
Starting symbol	2
Ratio of PDSCH EPRE to PDCCH EPRE	0 dB
Starting PRB location	0
Number of PRBs	3

#### 4.9.2.2.1 NR FR2 test model 1.1 (NR-FR2-TM1.1)

This model shall be used for tests on:

- Radiated transmit power
- BS output power

- Transmit ON/OFF power
- TAE
- Unwanted emissions
  - Occupied bandwidth
  - ACLR
  - Operating band unwanted emissions
  - Transmitter spurious emissions
- Receiver spurious emissions

Common physical channel parameters are defined in clause 4.9.2.2. Specific physical channel parameters for NR-FR2-TM1.1 are defined in table 4.9.2.2.1-1.

**Table 4.9.2.2.1-1: Specific physical channel parameters of NR-FR2-TM1.1**

Parameter	Value
# of PRBs PDSCH $n_{\text{RNTI}} = 0$	$N_{\text{RB}} - 3$
Modulation PDSCH $n_{\text{RNTI}} = 0$	QPSK
Starting RB location of PDSCH $n_{\text{RNTI}} = 0$	3
Modulation of PDSCH $n_{\text{RNTI}} = 2$	QPSK
Starting RB location of PDSCH $n_{\text{RNTI}} = 2$	0

4.9.2.2.2 NR FR2 test model 2 (NR-FR2-TM2)

This model shall be used for tests on:

- Total power dynamic range (lower OFDM symbol TX power limit (OSTP) at min power)
- EVM of single PRB allocation (at min power)
- Frequency error (at min power)

Common physical channel parameters are defined in clause 4.9.2.2. Specific physical channel parameters for NR-FR2-TM2 are defined in table 4.9.2.2.2-1 for 64QAM. For 16QAM and QPSK, specific physical channel parameters for NR-FR2-TM2 are defined in table 4.9.2.2.2-1 with 64QAM PDSCH PRB replaced with selected modulation order PDSCH PRB according to the corresponding test procedure.

**Table 4.9.2.2.2-1: Specific physical channel parameters of NR-FR2-TM2**

Parameter	Value												
# of 64QAM PDSCH PRBs	1												
Level of boosting (dB)	0												
Location of 64QAM PRB	<table style="border: none;"> <tr> <td style="padding-right: 20px;">Slot</td> <td style="padding-right: 20px;">RB</td> <td style="text-align: center;"><math>n</math></td> </tr> <tr> <td style="padding-right: 20px;"><math>3n</math></td> <td style="padding-right: 20px;">0</td> <td style="text-align: center;"><math>n = 0, \dots, \left\lfloor \frac{10 \times 2^\mu - 1}{3} \right\rfloor - 1</math></td> </tr> <tr> <td style="padding-right: 20px;"><math>3n+1</math></td> <td style="padding-right: 20px;"><math>\left\lfloor \frac{N_{\text{RB}}}{2} \right\rfloor</math></td> <td style="text-align: center;"><math>n = 0, \dots, \left\lfloor \frac{10 \times 2^\mu - 1}{3} \right\rfloor - 1</math></td> </tr> <tr> <td style="padding-right: 20px;"><math>3n+2</math></td> <td style="padding-right: 20px;"><math>N_{\text{RB}} - 1</math></td> <td style="text-align: center;"><math>n = 0, \dots, \left\lfloor \frac{10 \times 2^\mu - 2}{3} \right\rfloor - 1</math></td> </tr> </table>	Slot	RB	$n$	$3n$	0	$n = 0, \dots, \left\lfloor \frac{10 \times 2^\mu - 1}{3} \right\rfloor - 1$	$3n+1$	$\left\lfloor \frac{N_{\text{RB}}}{2} \right\rfloor$	$n = 0, \dots, \left\lfloor \frac{10 \times 2^\mu - 1}{3} \right\rfloor - 1$	$3n+2$	$N_{\text{RB}} - 1$	$n = 0, \dots, \left\lfloor \frac{10 \times 2^\mu - 2}{3} \right\rfloor - 1$
Slot	RB	$n$											
$3n$	0	$n = 0, \dots, \left\lfloor \frac{10 \times 2^\mu - 1}{3} \right\rfloor - 1$											
$3n+1$	$\left\lfloor \frac{N_{\text{RB}}}{2} \right\rfloor$	$n = 0, \dots, \left\lfloor \frac{10 \times 2^\mu - 1}{3} \right\rfloor - 1$											
$3n+2$	$N_{\text{RB}} - 1$	$n = 0, \dots, \left\lfloor \frac{10 \times 2^\mu - 2}{3} \right\rfloor - 1$											
# of PDSCH PRBs which are not allocated	$N_{\text{RB}} - 1$												

4.9.2.2.2a NR FR2 test model 2a (NR-FR2-TM2a)

This model shall be used for tests on:

- Total power dynamic range (lower OFDM symbol power limit at min power)

- EVM of single 256QAM PRB allocation (at min power)
- Frequency error (at min power)

Common physical channel parameters are defined in clause 4.9.2.2. Specific physical channel parameters for NR-FR2-TM2a are defined in table 4.9.2.2.1 with all 64QAM PDSCH PRBs replaced by 256QAM PDSCH PRBs.

#### 4.9.2.2.3 NR FR2 test model 3.1 (NR-FR2-TM3.1)

This model shall be used for tests on:

- Output power dynamics
  - Total power dynamic range (upper OFDM symbol TX power limit (OSTP) at max power with all PRBs allocated)
- Transmitted signal quality
  - Frequency error
  - EVM for modulation (at max power)

NOTE: EVM shall be evaluated over PDSCH allocated PRBs with  $n_{\text{RNTI}} = 0$  and  $n_{\text{RNTI}} = 2$ .

Common physical channel parameters are defined in clause 4.9.2.2. Specific physical channel parameters for NR-FR2-TM3.1 are defined in table 4.9.2.2.1-1 with all QPSK PDSCH PRBs replaced with selected modulation order PDSCH PRBs according to the corresponding test procedure.

#### 4.9.2.2.4 NR FR2 test model 3.1a (NR-FR2-TM3.1a)

This model shall be used for tests on:

- Output power dynamics
  - Total power dynamic range (upper OFDM symbol power limit at max power with all 256QAM PRBs allocated)
- Transmitted signal quality
  - Frequency error
  - EVM for 256QAM modulation (at max power)

NOTE: EVM shall be evaluated over PDSCH allocated PRBs with  $n_{\text{RNTI}} = 0$  and  $n_{\text{RNTI}} = 2$ .

Common physical channel parameters are defined in clause 4.9.2.2. Specific physical channel parameters for NR-FR2-TM3.1a shall be defined in table 4.9.2.2.1-1 with all QPSK PDSCH PRBs replaced by 256QAM.

### 4.9.2.3 Data content of physical channels and signals for NR-FR2-TM

Randomisation of the data content is obtained by utilizing a PN sequence generator and the length-31 Gold sequence scrambling of TS 38.211 [20], clause 5.2.1 which is invoked by all physical channels prior to modulation and mapping to the RE grid.

Initialization of the scrambler and RE-mappers as defined in TS 38.211 [20] use the following additional parameters:

- $N_{ID}^{cell} = 1$  for the lowest configured carrier,  $N_{ID}^{cell} = 2$  for the 2<sup>nd</sup> lowest configured carrier, ...  $N_{ID}^{cell} = n$  for the n<sup>th</sup> configured carrier
- Antenna ports starting with 2000 for PDCCH
- $q = 0$  (single code word)
- For NR-FR2-TM1.1 when used for TAE requirement of two-layers MIMO transmission

- Rank 2, two layers, no precoding
- Antenna ports starting with 1000 and 1001 for PDSCH

Otherwise

- Rank 1, single layer
- Antenna port starting with 1000 for PDSCH

#### 4.9.2.3.1 PDCCH

- $N_{sym}^{CORESET} = 2$
- PDCCH modulation to be QPSK as described in TS 38.211 [20], clause 5.1.3.
- For each slot the required amount of bits for all PDCCHs is as follows: 1(# of PDCCH) \* 1(# of CCE per PDCCH) \* 6(REG per CCE) \* 9(data RE per REG) \* 2(bits per RE) with these parameters according to the NR-FR2-TM definitions in clause 4.4.9.2.2.
- Generate this amount of bits from the output of the PN23 sequence generator [28]. For FR2-1, the PN sequence generator is initialized with a starting seed of "all ones" in the first allocated slot of each frame. The PN sequence is continuous over the slot boundaries. For FR2-2, the PN sequence generator is initialized with a starting seed of "all ones" in the first allocated slot of each 80 slots time period of test model length, identical payload data sequence repeated in following 80 slot. The PN sequence is continuous over the slot boundaries.
- 1 CCE shall be according to TS 38.211 [20], clause 7.3.2. PDCCH using non-interleaved CCE-to-REG mapping. PDCCH occupies the first two symbols for 6 resource-element groups, where a resource element group equals one resource block during one OFDM symbol.
- Perform PDCCH scrambling according to TS 38.211 [20], clause 7.3.2.3.
- $N_{ID} = N_{ID}^{cell}$  in DM-RS sequence generation in TS 38.211 [20], clause 7.4.1.3.
- $n_{RNTI} = 0$  in scrambling sequence generation in TS 38.211 [20], clause 7.3.2.3.
- Perform mapping to REs according to TS 38.211 [20], clause 7.3.2.5.

#### 4.9.2.3.2 PDSCH

- Generate the required amount of bits from the output of the PN23 sequence generator [28]. For FR2-1, the PN sequence generator is initialized with a starting seed of "all ones" in the first allocated slot of each frame. For FR2-2, the PN sequence generator is initialized with a starting seed of "all ones" in the first allocated slot of each 80 slots time period of test model length, identical payload data sequence repeated in following 80 slot. The PN sequence is continuous over the slot boundaries. For TDD TMs, the PN sequence can be generated for all symbols (in the DL, UL or special slots) or only DL symbols (in the DL or special slots). For TMs with multi-users, the PN sequence can be generated per user ( $n_{RNTI}$ ).
- NR-FR2-TMs utilize 1 or 2 user PDSCH transmissions distinguished by  $n_{RNTI}$ . For each NR-FR2-TM, PRBs are mapped to user ( $n_{RNTI}$ ) as follows:

**Table 4.9.2.3.2-1: Mapping of PRBs to  $n_{RNTI}$  for NR-FR2-TM**

Test model	$n_{RNTI}$	Number of users
NR-FR2-TM1.1	2 for PRBs located in PRB#0-2 0 for remaining PRBs	2
NR-FR2-TM2	2 for all PRBs	1
NR-FR2-TM2a	2 for all PRBs	1
NR-FR2-TM3.1	2 for PRBs located in PRB#0-2 0 for remaining PRBs	2
NR-FR2-TM3.1a	2 for PRBs located in PRB#0-2 0 for remaining PRBs	2

- Perform user specific scrambling according to TS 38.211 [20], clause 7.3.1.1.
- $n_{ID} = N_{ID}^{cell}$
- Perform modulation of the scrambled bits with the modulation scheme defined for each user according to TS 38.211 [20], clause 7.3.1.2.
- Perform mapping of the complex-valued symbols to layer according to TS 38.211 [20], clause 7.3.1.3.  
 $x^{(0)}(i) = d^{(0)}(i)$   $M_{symb}^{layer} = M_{symb}^{(0)}$  Complex-valued modulation symbols  $d^{(q)}(0), \dots, d^{(q)}(M_{symb}^{(q)} - 1)$  for codeword  $q$  shall be mapped onto the layers  $x(i) = [x^{(0)}(i) \dots x^{(v-1)}(i)]^T$ ,  $i = 0, 1, \dots, M_{symb}^{layer} - 1$  where  $v$  is equal to 1.
- Perform PDSCH mapping type A according to TS 38.211 [20].
- PDSCH resource allocation according to TS 38.214 [21] as following;
  - NR-FR2-TM1.1, NR-FR2-TM3.1, NR-FR2-TM3.1a: type 1 for PDSCH with  $n_{RNTI} = 0$ ,  $n_{RNTI} = 2$
  - NR-FR2-TM2, NR-FR2-TM2a: type 1 for PDSCH with  $n_{RNTI} = 2$
- DM-RS sequence generation according to TS 38.211 [20], clause 7.4.1.1.1 where  $l$  is the OFDM symbol number within the slot with symbols indicated by table 4.9.2.2-3.
- $N_{ID}^{nSCID} = N_{ID}^{cell}$
- $n_{SCID} = 0$
- DM-RS mapping according to TS 38.211 [20], clause 7.4.1.1.2 with parameters listed in table 4.9.2.2-3.
- For NR-FR2-TM PT-RS sequence generation according to TS 38.211 [20], clause 7.4.1.2.1, with parameters listed in table 4.9.2.2-3.
- For NR-FR2-TM PT-RS mapping according to TS 38.211 [20], clause 7.4.1.2.2, with parameters listed in table 4.9.2.2-3.

## 4.10 Requirements for contiguous and non-contiguous spectrum

A spectrum allocation where a BS operates can either be contiguous or non-contiguous. Unless otherwise stated, the requirements in the present specification apply for BS configured for both contiguous spectrum operation and non-contiguous spectrum operation.

For BS operation in non-contiguous spectrum, some requirements apply both at the *Base Station RF Bandwidth* edges and inside the sub-block gaps. For each such requirement, it is stated how the limits apply relative to the Base Station RF Bandwidth edges and the sub-block edges respectively.

There are no CA requirements for ATG BS in the present specification.

## 4.11 Requirements for BS capable of multi-band operation

For *multi-band RIB*, the radiated test requirements in clause 6 and 7 apply separately to each supported *operating band*, unless otherwise stated. For some radiated test requirements, it is explicitly stated that specific additions or exclusions to the test requirement apply at *multi-band RIB(s)* as detailed in the requirement clause.

*BS type 1-O* may be capable of supporting operation in multiple *operating bands* with one of the following implementations at the *radiated interface boundary*:

- All RIBs are single-band RIBs.
- All RIBs are *multi-band RIBs*.
- A combination of single-band *RIBs* and *multi-band RIBs* provides support of the *BS type 1-O* capability of operation in multiple *operating bands*.

For *multi-band RIBs* supporting the bands for TDD, the radiated test requirements in the present specification assume no simultaneous uplink and downlink occur between the bands.

NOTE: The radiated test requirements for *multi-band RIBs* supporting bands for both FDD and TDD are not covered by the present release of this specification.

There is no multi-band operation requirement for ATG BS.

## 4.12 Co-location requirements

### 4.12.1 General

Co-location requirements are requirements which are based on assuming the *BS type I-O* is co-located with another BS of the same base station class. They ensure that both co-located systems can operate with minimal degradation to each other.

The co-location requirements in table 4.12.1-1 rely on a *co-location reference antenna* used to mimic a base station to base station co-location scenario.

**Table 4.12.1-1: Co-location requirements**

Clause number	Requirement	Co-location reference antenna operation	Type
6.5	OTA transmit ON/OFF power for FR1	Measure emission	Mandatory
6.7.5.3 6.7.5.5	OTA spurious emission: Protection of the BS receiver of own or different BS OTA spurious emission: Co-location with other base stations	Measure emission	Optional based on declaration
6.8	OTA transmitter intermodulation	Inject the interferer signal	Mandatory
7.6.3	OTA out-of-band blocking: Co-location with other base stations	Inject the interferer signal	Optional based on declaration

The OTA transmit ON/OFF power requirement and OTA transmitter intermodulation requirement are mandatory requirements where the test requirement is derived using the *co-location reference antenna*, which represents the worst-case scenario.

The *co-location reference antenna* is defined in TS 38.104 [2].

### 4.12.2 Co-location test antenna

#### 4.12.2.1 General

Co-location requirements are specified as power levels into or out of the conducted interface of the *co-location reference antenna*. For conformance testing the requirements are translated to the input or output of a *co-location test antenna* (CLTA).

A CLTA is a practical antenna which can be used to test conformance to the co-location requirements.

#### 4.12.2.2 Co-location test antenna characteristics

A *co-location test antenna* is a practical passive antenna that is used for conformance testing of the co-location requirements and is based on the definition of the *co-location reference antenna*. A CLTA shall comply with the requirements specified in table 4.12.2.2-1.

Translation of the requirements to other test antennas are not precluded but suitable translations between the co-location reference antenna and test antenna must be provided to demonstrate that the method is within the specified MU.

NOTE: The currently defined CLTAs are suitable for testing *BS type 1-O* implemented with a planar antenna array. The method for testing BS with other antenna array implementations is not covered by the present release of this specification.

**Table 4.12.2.2-1: CLTA characteristics**

Parameter	In-band CLTA	Out-of-band CLTAs
Vertical radiating dimension (h)	Test object vertical radiating length $\pm 30\%$	Test object vertical radiating length $\pm 30\%$ (Note 2)
Horizontal beam width	$65^\circ \pm 10^\circ$	$65^\circ \pm 10^\circ$
Vertical beam width	N/A	The half-power vertical beam width of the CLTA equals the narrowest declared (D.3) vertical beamwidth $\pm 3^\circ$ (Note 2)
Polarization (Note 3)	Match (Note4)	Match to in-band (Note 4)
Conducted interface return loss	> 10 dB	> 10 dB
NOTE 1: If a multi-column or multi-band antenna is used the column closest to the NR BS shall be selected while other columns are terminated during testing.		
NOTE 2: The vertical radiating dimension definition shall be used instead of the vertical beam width definition when the test chamber dimensions limit the use of vertical beam width definition. Otherwise the vertical beam width definition shall be used.		
NOTE 3: For <i>BS type 1-O</i> with dual polarization the CLTA has two conducted interfaces each representing one polarization.		
NOTE 4: Matched to the polarization of EUT antenna.		

#### 4.12.2.3 Co-location test antenna alignment

The alignment between the NR BS under test and the *co-location test antenna* is described in table 4.12.2.3-1 and figure 4.12.2.3-1. The same physical alignment applies to in-band and out-of-band co-location requirements.

**Table 4.12.2.3-1: CLTA alignment tolerances**

Parameter	
Edge-to-edge separation between the NR BS and the CLTA, d	0.1 m $\pm$ 0.01 m
Vertical alignment	Centre $\pm$ 0.01 m
Front alignment	Radome front $\pm$ 0.01 m



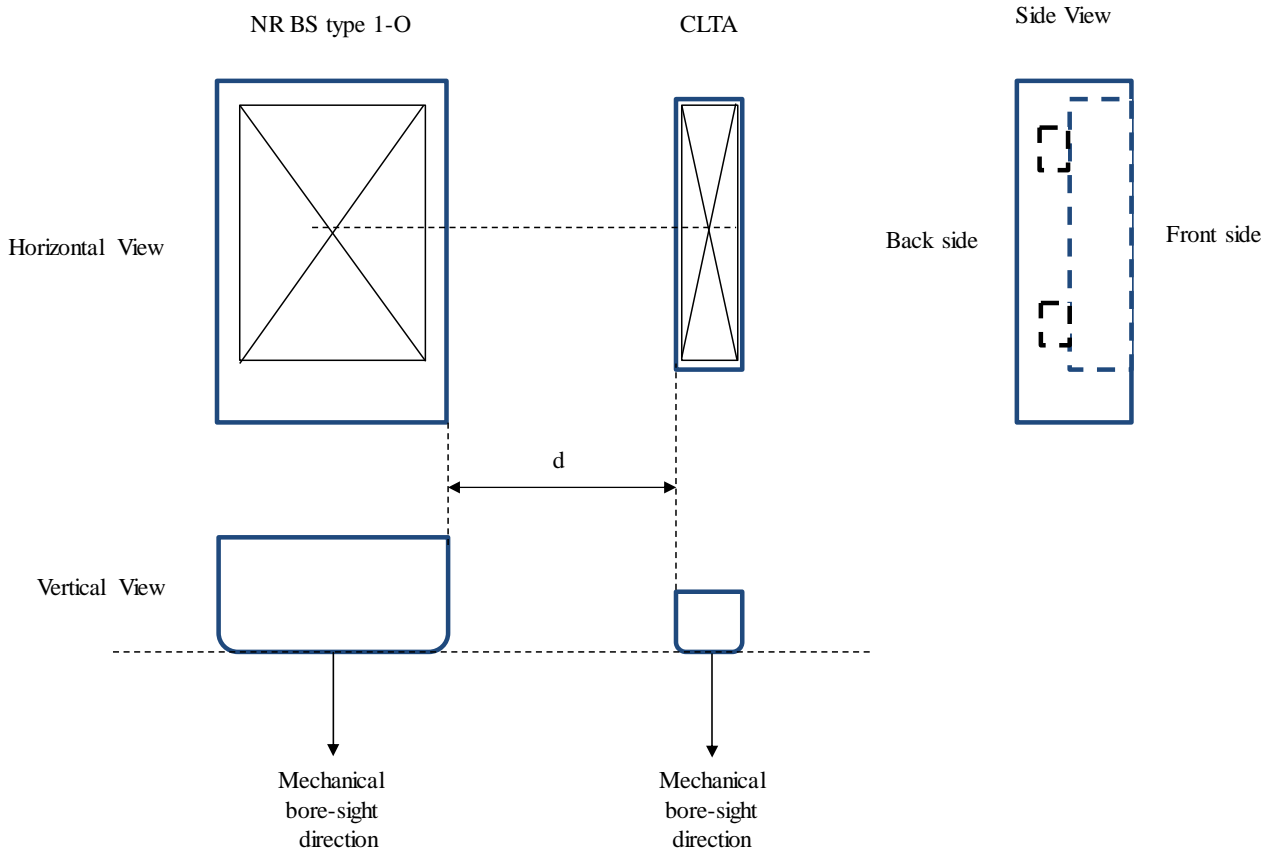

**Figure 4.12.2.3-1: Alignment of NR BS and CLTA**

## 4.13 Format and interpretation of tests

Each test has a standard format:

### X Title

All tests are applicable to all equipment within the scope of the present document, unless otherwise stated.

#### X.1 Definition and applicability

This clause gives the general definition of the parameter under consideration and specifies whether the test is applicable to all equipment or only to a certain subset. Required manufacturer declarations may be included here.

#### X.2 Minimum requirement

This clause contains the reference to the clause to the 3GPP reference (or core) specification which defines the minimum requirement.

#### X.3 Test purpose

This clause defines the purpose of the test.

#### X.4 Method of test

##### X.4.1 General

In some cases there are alternative test procedures or initial conditions. In such cases, guidance for which initial conditions and test procedures can be applied are stated here. In the case only one test procedure is applicable, that is stated here.

##### X.4.2y First test method

#### X.4.2y.1 Initial conditions

This clause defines the initial conditions for each test, including the test environment, the RF channels to be tested and the basic measurement set-up. The OTA Test System is assumed to be correctly calibrated as part of the initial conditions. Calibration is not explicitly mentioned.

#### X.4.2y.2 Procedure

This clause describes the steps necessary to perform the test and provides further details of the test definition like domain (e.g. frequency-span), range, weighting (e.g. bandwidth), and algorithms (e.g. averaging). The procedure may comprise data processing of the measurement result before comparison with the test requirement (e.g. average result from several measurement positions).

#### X.4.3y Alternative test method (if any)

If there are alternative test methods, each is described with its initial conditions and procedures.

#### X.5 Test requirement

This clause defines the pass/fail criteria for the equipment under test, see clause 4.1.3 (Interpretation of measurement results). Test requirements for every minimum requirement referred in clause X.2 are listed here. Cases where minimum requirements do not apply need not be mentioned.

## 4.14 Reference coordinate system

Radiated requirements are stated in terms of electromagnetic characteristics (e.g. EIRP and EIS) at certain angles with respect to the base station. To be able to declare radiated characteristics part of radiated requirements a reference coordinate system is required. The reference coordinate system is should be associated to an identifiable physical feature on the base station enclosure. The location of the origin and the orientation of the reference coordinate system are for the base station manufacturer to declare.

The reference coordinate system is created of a Cartesian coordinate system with rectangular axis ( $x$ ,  $y$ ,  $z$ ) and spherical angles ( $\theta$ ,  $\phi$ ) as showed in figure 4.14-1.

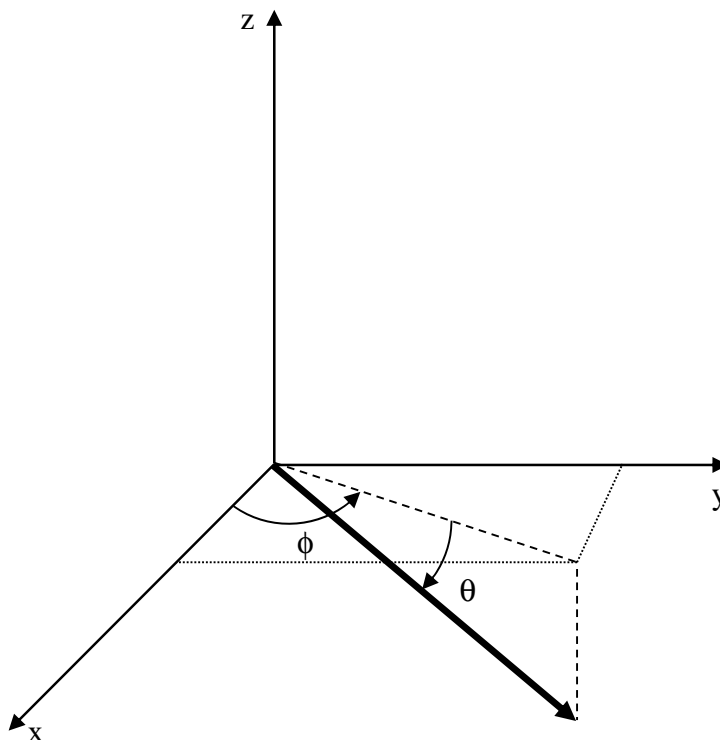

Figure 4.14-1: Reference coordinate system

$\phi$  is the angle in the x/y plane, between the x-axis and the projection of the radiating vector onto the x/y plane and is defined between  $-180^\circ$  and  $+180^\circ$ , inclusive.  $\theta$  is the angle between the projection of the vector in the x/y plane and the radiating vector and is defined between  $-90^\circ$  and  $+90^\circ$ , inclusive. Note that  $\theta$  is defined as positive along the down-tilt angle.

---

## 5 Operating bands and channel arrangement

For the NR operating bands specification, their channel bandwidth configurations, channel spacing and raster, as well as synchronization raster specification, refer to TS 38.104 [2], clause 5 and its relevant clauses.

For radiated testing purposes in this specification, FR1 and FR2 operating bands are considered.

For ATG BS, their operating bands refer to TS 38.104.

## 6 Radiated transmitter characteristics

### 6.1 General

General test conditions for transmitter tests are given in clause 4, including interpretation of measurement results and configurations for testing. BS configurations for the tests are defined in clause 4.5.

If beams have been declared equivalent and parallel (D.13, D.14), only a representative beam is necessary to be tested to demonstrate conformance.

### 6.2 Radiated transmit power

#### 6.2.1 Definition and applicability

Radiated transmit power is defined as the EIRP level for a declared beam at a specific *beam peak direction*.

For each declared beam, the requirement is based on declarations captured in clause 4.6 for a beam identifier (D.3), *reference beam direction pair* (D.8), *rated beam EIRP* (D.11) at the beam's reference direction pair, *OTA peak directions set* (D.9), the *beam direction pairs* at the maximum steering directions (D.10) and their associated *rated beam EIRP* and *beamwidth(s)* for *reference beam direction pair* and maximum steering directions (D.12).

For a declared beam identifier and *beam direction pair*, the *rated beam EIRP* level is the maximum power that the BS is declared to radiate at the associated *beam peak direction* during the *transmitter ON period*.

For each *beam peak direction* associated with a *beam direction pair* within the *OTA peak directions set*, a specific *rated beam EIRP* level may be claimed. Any claimed value shall be met within the accuracy requirement as described below. *Rated beam EIRP* is only required to be declared for the *beam direction pairs* subject to conformance testing as detailed in clause 6.2.4.1.

NOTE 1: The *OTA peak directions set* for a beam is the complete continuous or discrete set of all *beam direction* for which the EIRP accuracy is intended to be achieved for the beam.

NOTE 2: A beam direction pair consists of a beam centre direction and an associated beam peak direction.

NOTE 3: A declared EIRP value is a value provided by the manufacturer for verification according to the conformance specification declaration requirements, whereas a claimed EIRP value is provided by the manufacturer to the equipment user for normal operation of the equipment and is not subject to formal conformance testing.

For *operating bands* where the supported *fractional bandwidth* (FBW) is larger than 6%, two rated carrier EIRP may be declared by manufacturer:

- $P_{\text{rated,c,FBWlow}}$  for lower supported frequency range, and
- $P_{\text{rated,c,FBWhigh}}$  for higher supported frequency range.

For frequencies in between  $F_{\text{FBWlow}}$  and  $F_{\text{FBWhigh}}$  the rated carrier EIRP is:

- $P_{\text{rated,c,FBWlow}}$ , for the carrier whose carrier frequency is within frequency range  $F_{\text{FBWlow}} \leq f < (F_{\text{FBWlow}} + F_{\text{FBWhigh}}) / 2$ ,
- $P_{\text{rated,c,FBWhigh}}$ , for the carrier whose carrier frequency is within frequency range  $(F_{\text{FBWlow}} + F_{\text{FBWhigh}}) / 2 \leq f \leq F_{\text{FBWhigh}}$ .

Radiated transmit power is directional requirement applicable to BS type 1-H, BS type 1-O and BS type 2-O.

For BS Type 1-H, for operation with shared spectrum channel access operation, the BS may have to comply with the applicable BS power limits established regionally, when deployed in regions where those limits apply and under the conditions declared by the manufacturer.

For BS type 1-H there is no requirement specified for band n46, n100, n101 and n102.

For *BS type 1-O* there is no requirement specified for bands n46, n96, n100, n101 and n102.

## 6.2.2 Minimum requirement

Radiated transmit power minimum requirement for *BS type 1-H* and *BS type 1-O* is defined in TS 38.104 [2], clause 9.2.2.

Radiated transmit power minimum requirement for *BS type 2-O* is defined in TS 38.104 [2], clause 9.2.3.

## 6.2.3 Test purpose

The test purpose is to verify the ability to accurately generate and direct radiated power per beam, across the frequency range and under normal conditions, for all declared beams of the *BS type 1-H*, *BS type 1-O* and *BS type 2-O*.

## 6.2.4 Method of test

### 6.2.4.1 Initial conditions

Test environments:

- Normal, see annex B.2.
- Extreme (*BS type 1-O* and *BS type 2-O* only), see annexes B.3 and B.5.

RF channels to be tested for single carrier: B, M and T; see clause 4.9.1.

*Base station RF bandwidth* positions to be tested for multi-carrier and/or CA:

- $B_{\text{RFBW}}$ ,  $M_{\text{RFBW}}$  and  $T_{\text{RFBW}}$  in single-band operation, see clause 4.9.1,
- $B'_{\text{RFBW}}T'_{\text{RFBW}}$  and  $B'_{\text{RFBW}}T_{\text{RFBW}}$  in multi-band operation, see clause 4.9.1.

Directions to be tested:

- OTA peak directions set reference beam direction pair (D.8), and
- OTA peak directions set maximum steering directions (D.10).

Beams to be tested:

- The *beam* with the highest *rated beam EIRP* (D.11), or
- The beams with highest *rated beam EIRP*, *Prated,c,FBWlow* (D.57) and *Prated,c,FBWhigh* (D.58), if these are provided.

Under extreme test environment, for the *BS type 1-O* and *BS type 2-O* it is sufficient to test on one NR-ARFCN or one RF bandwidth position, and with one applicable test configuration defined in clauses 4.7 and 4.8. Direction to be tested is only at *OTA peak directions set reference beam direction pair* (D.8). Testing shall be performed under extreme power supply conditions, as defined in annex B.5.

NOTE: Tests under extreme power supply conditions also test extreme temperatures.

### 6.2.4.2 Procedure

For normal test environment conditions in OTA domain, the test procedure is as follows:

- 1) Place the BS at the positioner.
- 2) Align the manufacturer declared coordinate system orientation (D.2) of the BS with the test system.

- 3) Orient the positioner (and BS) in order that the direction to be tested aligns with the test antenna.
- 4) Configure the *beam peak direction* of the BS according to the declared *beam direction pair*.
- 5) Set the BS to transmit according to the applicable test configuration in clause 4.8 using the corresponding test model(s) in clause 4.9.2.

For a BS declared to be capable of multi-carrier and/or CA operation use the applicable test signal configuration and corresponding power setting specified in clauses 4.7.2 and 4.8 using the corresponding test model(s) in clause 4.9.2 on all carriers configured.

- 6) Measure EIRP for any two orthogonal polarizations (denoted  $p_1$  and  $p_2$ ) and calculate total radiated transmit power for particular *beam direction pair* as  $EIRP = EIRP_{p_1} + EIRP_{p_2}$ .
- 7) Test steps 3 to 6 are repeated for all declared beams (D.3) and their reference *beam direction pairs* and *maximum steering directions* (D.8 and D.10).

For multi-band capable BS and single band tests, repeat the steps above per involved *operating band* where single band test configurations and test models shall apply with no carriers activated in the other band.

For extreme conditions tests the methods in annex B.7 may be used.

## 6.2.5 Test requirement

For each declared conformance *beam direction pair*, the EIRP measurement results in clause 6.2.4.2 shall remain within the values provided in table 6.2.5-1, relative to the manufacturer's declared rated beam EIRP (D.11) value:

**Table 6.2.5-1: Test requirement for radiated transmit power**

	Normal test environment	Extreme test environment
BS type 1-H	$f \leq 3$ GHz: $\pm 3.3$ dB	N/A
	3 GHz < $f \leq 7.125$ GHz: $\pm 3.5$ dB For band n96: $\pm 4.0$ dB	
BS type 1-O	$f \leq 3$ GHz: $\pm 3.3$ dB	$f \leq 3$ GHz: $\pm 5.2$ dB
	3 GHz < $f \leq 7.125$ GHz: $\pm 3.5$ dB	3 GHz < $f \leq 4.2$ GHz: $\pm 5.3$ dB
		4.2 GHz < $f \leq 7.125$ GHz: $\pm 5.3$ dB
BS type 2-O	24.15 GHz < $f \leq 29.5$ GHz: $\pm 5.1$ dB	24.15 GHz < $f \leq 29.5$ GHz: $\pm 7.6$ dB
	37 GHz < $f \leq 43.5$ GHz: $\pm 5.4$ dB	37 GHz < $f \leq 43.5$ GHz: $\pm 7.8$ dB
	43.5 GHz < $f \leq 48.2$ GHz: $\pm 5.6$ dB	43.5 GHz < $f \leq 48.2$ GHz: $\pm 8.0$ dB
	52.6 GHz < $f \leq 71$ GHz: $\pm 6.4$ dB	52.6 GHz < $f \leq 71$ GHz: $\pm 8.4$ dB

## 6.3 OTA base station output power

### 6.3.1 Definition and applicability

OTA BS output power is declared as rated carrier TRP, with the output power accuracy requirement defined at the RIB during the *transmitter ON period*.

The BS *rated carrier TRP* for BS type 1-O shall be within limits as specified in table 6.3.1-1.

**Table 6.3.1-1: BS rated carrier TRP limits for BS type 1-O**

BS class	$P_{\text{rated,c,TRP}}$
Wide Area BS	(note)
Medium Range BS	$\leq + 47$ dBm
Local Area BS	$\leq + 33$ dBm
NOTE: There is no upper limit for the $P_{\text{rated,c,TRP}}$ of the Wide Area Base Station.	

For Band n41 and n90 operation in Japan, the rated output power,  $P_{\text{rated,c,TRP}}$ , declared by the manufacturer shall be equal to or less than 20 W per 10 MHz bandwidth.

There is no upper limit for the *rated carrier TRP* of *BS type 2-O*.

Despite the general requirements for the BS output power described in TS 38.104 [2] clauses 9.3.2 – 9.3.3, additional regional requirements might be applicable.

NOTE: In certain regions, power limits corresponding to BS classes may apply for *BS type 2-O*.

## 6.3.2 Minimum requirement

The minimum requirement for *BS type 1-O* is in TS 38.104 [2], clause 9.3.2.

The minimum requirement for *BS type 2-O* is in TS 38.104 [2], clause 9.3.3.

## 6.3.3 Test purpose

The test purpose is to verify the accuracy of the *maximum carrier TRP* ( $P_{\max,c,TRP}$ ) across the frequency range for all *RIBs*.

## 6.3.4 Method of test

### 6.3.4.1 Initial conditions

Test environment: Normal, see annex B.2.

RF channels to be tested for single carrier: B, M, T; see clause 4.9.1.

*Base Station RF Bandwidth* positions to be tested for multi-carrier and/or CA:

- $B_{RFBW}$ ,  $M_{RFBW}$  and  $T_{RFBW}$  in single band operation; see clause 4.9.1.
- $B'_{RFBW}$ ,  $T'_{RFBW}$  and  $B'_{RFBW}$ ,  $T'_{RFBW}$  in multi-band operation, see clause 4.9.1.

Beams to be tested:

As the requirement is TRP the beam pattern(s) may be set up to optimise the TRP measurement procedure (see annex I).

### 6.3.4.2 Procedure

The following procedure for measuring TRP is based on the directional power measurements as described in annex I. An alternative method to measure TRP is to use a characterized and calibrated reverberation chamber. If so, follow steps 1, 3, 5, and 7. When calibrated and operated within the guidance of 3GPP TR 37.941 [29] the measurement methods are applicable and selected depending on availability at the test facility.

- 1) Place the BS at the positioner.
- 2) Align the manufacturer declared coordinate system orientation (D.2) of the BS with the test system.
- 3) Configure the BS such that the beam peak direction(s) applied during the power measurement step 6 are consistent with the grid and measurement approach for the TRP test.
- 4) Set the BS to transmit according to the applicable test configuration in clause 4.8 using the corresponding test model(s) in clause 4.9.2.

For a BS declared to be capable of multi-carrier and/or CA operation use the applicable test signal configuration and corresponding power setting specified in clauses 4.7.2 and 4.8 using the corresponding test model(s) in clause 4.9.2 on all carriers configured.

- 5) Orient the positioner (and BS) in order that the direction to be tested aligns with the test antenna such that measurements to determine TRP can be performed (see annex I).
- 6) Measure the radiated power for any two orthogonal polarizations (denoted p1 and p2) and calculate total radiated transmit power for particular beam direction pair as  $EIRP = EIRP_{p1} + EIRP_{p2}$ .



If the test chamber is a reverberation chamber measure TRP directly.

- 7) Repeat step 6-7 for all directions in the appropriated TRP measurement grid needed for full TRP estimation (see annex I).
- 8) Calculate TRP using the EIRP measurements.

For *multi-band RIBs* and single band tests, repeat the steps above per involved band where single band test configurations and test models shall apply with no carriers activated in the other band.

## 6.3.5 Test requirement

### 6.3.5.1 BS type 1-0

The final TRP measurement result in clause 6.3.4.2 shall remain:

- within +3.4 dB and -3.4 dB of the manufacturer's declared *rated carrier TRP*  $P_{\text{rated,c,TRP}}$  carrier frequency  $f \leq 3.0$  GHz;
- within +3.5 dB and -3.5 dB of the manufacturer's declared *rated carrier TRP*  $P_{\text{rated,c,TRP}}$  for carrier frequency  $3.0 \text{ GHz} < f \leq 4.2 \text{ GHz}$ .
- within +3.5 dB and -3.5 dB of the manufacturer's declared *rated carrier TRP*  $P_{\text{rated,c,TRP}}$  for carrier frequency  $4.2 \text{ GHz} < f \leq 7.125 \text{ GHz}$ .

### 6.3.5.2 BS type 2-0

The final TRP measurement result in clause 6.3.4.2 shall remain:

- within +5.1 dB and -5.1 dB of the manufacturer's declared *rated carrier TRP*  $P_{\text{rated,c,TRP}}$  carrier frequency  $24.25 \text{ GHz} < f \leq 29.5 \text{ GHz}$ .
- within +5.4 dB and -5.4 dB of the manufacturer's declared *rated carrier TRP*  $P_{\text{rated,c,TRP}}$  for carrier frequency  $37 \text{ GHz} < f \leq 43.5 \text{ GHz}$ .
- within +5.6 dB and -5.6 dB of the manufacturer's declared *rated carrier TRP*  $P_{\text{rated,c,TRP}}$  for carrier frequency  $43.5 \text{ GHz} < f \leq 48.2 \text{ GHz}$ .
- within +6.2 dB and -6.2 dB of the manufacturer's declared *rated carrier TRP*  $P_{\text{rated,c,TRP}}$  for carrier frequency  $52.6 \text{ GHz} \leq f \leq 71 \text{ GHz}$ .

## 6.4 OTA output power dynamics

### 6.4.1 General

The requirements in clause 6.4 apply during the *transmitter ON period*. Transmit signal quality (as specified in clause 6.6) shall be maintained for the output power dynamics requirements.

The OTA output power requirements are single direction requirements and apply to the beam peak directions over the OTA peak directions set.

### 6.4.2 OTA RE power control dynamic range

#### 6.4.2.1 Definition and applicability

The OTA RE power control dynamic range is the difference between the power of an RE and the average RE power for a BS at maximum output power ( $P_{\text{max,c,EIRP}}$ ) for a specified reference condition.

This requirement shall apply at each RIB supporting transmission in the *operating band*.

### 6.4.2.2 Minimum requirement

The minimum requirement for *BS type 1-O* is in TS 38.104 [2], clause 9.4.2.2.

### 6.4.2.3 Method of test

No specific test or test requirements are defined for RE power control dynamic range. The Error Vector Magnitude test, as described in clause 6.6 provides sufficient test coverage for this requirement.

## 6.4.3 OTA total power dynamic range

### 6.4.3.1 Definition and applicability

The OTA total power dynamic range is the difference between the maximum and the minimum transmit power of an OFDM symbol for a specified reference condition.

This requirement shall apply at each RIB supporting transmission in the *operating band*.

NOTE: The upper limit of the OTA total power dynamic range is the BS maximum carrier EIRP ( $P_{\max,c,EIRP}$ ) when transmitting on all RBs. The lower limit of the OTA total power dynamic range is the average EIRP for single RB transmission in the same direction using the same beam. The OFDM symbols shall carry PDSCH and not contain PDCCH, RS or SSB.

### 6.4.3.2 Minimum requirement

The minimum requirement for *BS type 1-O* is in TS 38.104 [2], clause 9.4.3.2.

The minimum requirement for *BS type 2-O* is in TS 38.104 [2], clause 9.4.3.3.

### 6.4.3.3 Test purpose

The test purpose is to verify that the total power dynamic range is within the limits specified by the minimum requirement.

### 6.4.3.4 Method of test

#### 6.4.3.4.1 Initial conditions

Test environment: Normal, see annex B.2.

RF channels to be tested for single carrier:  $M$ ; see clause 4.9.1.

Beams to be tested: Declared beam with the highest intended EIRP for the narrowest intended beam corresponding to the smallest  $BeW\theta$ , or for the narrowest intended beam corresponding to the smallest  $BeW\phi$  (D.3, D.11).

Directions to be tested: The OTA peak directions set reference beam direction pair (D.8).

#### 6.4.3.4.2 Procedure

- 1) Place the BS at the positioner.
- 2) Align the manufacturer declared coordinate system orientation (D.2) of the BS with the test system.
- 3) Orient the positioner (and BS) in order that the direction to be tested aligns with the test antenna.
- 4) Configure the beam peak direction of the BS according to the declared beam direction pair.
- 5) For *BS type 1-O*, set the BS to transmit a signal according to the applicable test configuration in clause 4.8 using the corresponding test models:
  - NR-FR1-TM3.1b if 1024QAM is supported by BS without power back off, or

- NR-FR1-TM3.1a in TS 38.141-1 [3] clause 4.9.2.2.6 if 1024QAM is not supported by BS without power back off but 256QAM is supported by BS without power back off, or
- NR-FR1-TM3.1 in TS 38.141-1 [3] clause 4.9.2.2.5 if 1024QAM and 256QAM are both not supported by BS without power back off. For *BS type 2-O*, set the BS to transmit a signal according to the applicable test configuration in clause 4.8 using the corresponding test model:
  - NR-FR2-TM3.1a if 256QAM is supported by BS without power back off, or
  - NR-FR2-TM3.1 if 256QAM is supported by BS with power back off, or 256QAM is not supported by BS; with 64QAM signals if 64QAM is supported by BS without power back off, or;
  - NR-FR2-TM3.1 with highest modulation order supported without power back off if 64QAM is not supported by BS, or;
  - NR-FR2-TM3.1 with highest modulation order supported without power back off if 64QAM is supported by BS with power back off;
- 6) Measure the OFDM symbol TX power as defined in annex L by measuring the EIRP for any two orthogonal polarizations (denoted p1 and p2) and calculate total radiated transmit power for particular *beam direction pair* as  $EIRP = EIRP_{p1} + EIRP_{p2}$ .
- 7) For *BS type 1-O*, set the BS to transmit a signal according to the applicable test configuration in clause 4.8 using the corresponding test models:
  - NR-FR1-TM2b if 1024QAM is supported by BS, or
    - NR-FR1-TM2a in TS 38.141-1 [3] clause 4.9.2.2.4 if 1024QAM is not supported by BS and 256QAM is supported by BS; or
    - NR-FR1-TM2 in TS 38.141-1 [3] clause 4.9.2.2.3 if 1024QAM and 256QAM is not supported by BS;

For *BS type 2-O*, set the BS to transmit a signal according to the applicable test configuration in clause 4.8 using the corresponding test models:

  - NR-FR2-TM2a if 256QAM is supported by BS, or;
  - NR-FR2-TM2 with highest modulation order supported if 256QAM is not supported by BS;
- 8) Measure the OFDM symbol TX power (OSTP) as defined in annex L by measuring the EIRP for any two orthogonal polarizations (denoted p1 and p2) and calculate total radiated transmit power for particular *beam direction pair* as  $EIRP = EIRP_{p1} + EIRP_{p2}$ .

The measured OFDM symbols shall not contain RS or SSB.

In addition, for *multi-band RIB(s)*, the following steps shall apply:

- 9) For *multi-band RIBs* and single band tests, repeat the steps above per involved band where single band test configurations and test models shall apply with no carrier activated in the other band.

### 6.4.3.5 Test requirement

#### 6.4.3.5.1 *BS type 1-O*

The downlink (DL) total power dynamic range for each NR carrier shall be larger than or equal to the level in table 6.4.3.5.1-1.

**Table 6.4.3.5.1-1: Total power dynamic range**

BS channel bandwidth (MHz)	Total power dynamic range (dB)		
	15 kHz SCS	30 kHz SCS	60 kHz SCS
5	13.5	10	N/A
10	16.7	13.4	10
15	18.5	15.3	12.1
20	19.8	16.6	13.4
25	20.8	17.7	14.5
30	21.6	18.5	15.3
35	22.7	19.6	16.4
40	22.9	19.8	16.6
45	23.8	20.7	17.6
50	23.9	20.8	17.7
60	N/A	21.6	18.5
70	N/A	22.3	19.2
80	N/A	22.9	19.8
90	N/A	23.4	20.4
100	N/A	23.9	20.9

NOTE: Additional test requirements for the Error Vector Magnitude (EVM) at the lower limit of the dynamic range are defined in clause 6.6.

#### 6.4.3.5.2 BS type 2-O

OTA total power dynamic range minimum requirement for *BS type 2-O* is specified such as for each NR carrier it shall be larger than or equal to the levels specified in table 6.4.3.5.2-1 in FR2-1 and table 6.4.3.5.2-2 in FR2-2.

**Table 6.4.3.5.2-1: Minimum requirement for BS type 2-O total power dynamic range in FR2-1**

SCS (kHz)	50 MHz	100 MHz	200 MHz	400 MHz
	OTA total power dynamic range (dB)			
60	17.7	20.8	23.8	N/A
120	14.6	17.7	20.8	23.8

**Table 6.4.3.5.2-2: Minimum requirement for BS type 2-O total power dynamic range in FR2-2**

SCS (kHz)	OTA total power dynamic range (dB)				
	100 MHz	400 MHz	800 MHz	1600 MHz	2000 MHz
120	17.7	23.8	N/A	N/A	N/A
480	N/A	17.7	20.8	23.8	N/A
960	N/A	14.7	17.7	20.8	[21.5]

NOTE: Additional test requirements for the EVM at the lower limit of the dynamic range are defined in clause 6.6.

## 6.5 OTA transmit ON/OFF power

### 6.5.1 OTA transmitter OFF power

#### 6.5.1.1 Definition and applicability

OTA transmitter OFF power requirements apply only to TDD operation of NR BS.

OTA transmitter OFF power is defined as the mean power measured over  $70/N \mu\text{s}$  filtered with a square filter of bandwidth equal to the transmission bandwidth configuration of the BS ( $BW_{\text{Config}}$ ) centred on the assigned channel frequency during the *transmitter OFF period*.  $N = \text{SCS}/15$ , where SCS is Sub Carrier Spacing in kHz.

For BS supporting intra-band contiguous CA, the transmitter OFF power is defined as the mean power measured over  $70/N$   $\mu$ s filtered with a square filter of bandwidth equal to the *aggregated BS channel bandwidth*  $BW_{\text{Channel\_CA}}$  centred on  $(F_{\text{edge\_high}}+F_{\text{edge\_low}})/2$  during the *transmitter OFF period*.  $N = \text{SCS}/15$ , where SCS is the smallest supported Sub Carrier Spacing in kHz in the *aggregated BS channel bandwidth*.

For *BS type 1-O*, the transmitter OFF power is defined as the output power at the *co-location test antenna* conducted output(s). For *BS type 2-O* the transmitter OFF power is defined as TRP.

For *multi-band RIBs* or *single band RIBs* supporting transmission in multiple bands, the requirement is only applicable during the *transmitter OFF period* in all supported *operating bands*.

### 6.5.1.2 Minimum requirement

The minimum requirement for *BS type 1-O* is in TS 38.104 [2], clause 9.5.2.2.

The minimum requirement for *BS type 2-O* is in TS 38.104 [2], clause 9.5.2.3.

### 6.5.1.3 Test purpose

The purpose of this test is to verify the OTA transmitter OFF power is within the limits of the minimum requirements.

### 6.5.1.4 Method of test

Requirement is tested together with transmitter transient period, as described in clause 6.5.2.4.

### 6.5.1.5 Test requirements

The conformance testing of transmit OFF power is included in the conformance testing of transmitter transient period; therefore, see clause 6.5.2.5 for test requirements.

## 6.5.2 OTA transmitter transient period

### 6.5.2.1 Definition and applicability

The OTA *transmitter transient period* requirements apply only to TDD operation of BS.

The OTA *transmitter transient period* is the time period during which the transmitter unit is changing from the OFF period to the ON period or vice versa. The OTA *transmitter transient period* is illustrated in figure 6.5.2.1-1.

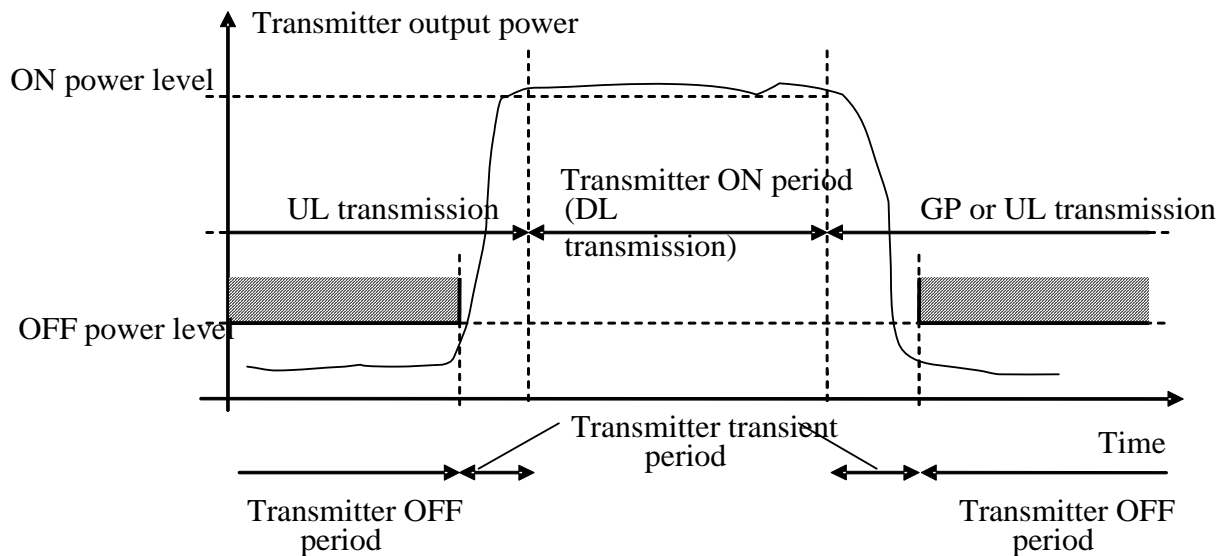

**Figure 6.5.2.1-1: Illustration of the relations of transmitter ON period, transmitter OFF period and transmitter transient period**

For *BS type 1-O*, this requirement applies for RIB supporting transmission in the *operating band* and is measured at the *co-location test antenna* conducted outputs. For *BS type 2-O*, the requirement applies at each RIB supporting transmission in the *operating band*.

### 6.5.2.2 Minimum requirement

The minimum requirement for *BS type 1-O* is in TS 38.104 [2], clause 9.5.3.2.

The minimum requirement for *BS type 2-O* is in TS 38.104 [2], clause 9.5.3.3.

### 6.5.2.3 Test purpose

The purpose of this test is to verify the OTA transmitter transient periods are within the limits of the minimum requirements.

### 6.5.2.4 Method of test

#### 6.5.2.4.1 Initial conditions

Test environment: Normal; see annex B.2.

RF channels to be tested: M; see clause 4.9.1.

*Base Station RF Bandwidth* positions to be tested for multi-carrier and/or CA:

- $M_{\text{RFBW}}$  in single band operation, see clause 4.9.1;
- $B_{\text{RFBW\_T'RFBW}}$  and  $B'_{\text{RFBW\_T'RFBW}}$  in multi-band operation; see clause 4.9.1.

Directions to be tested:

- The requirement for *BS type 1-O* is specified as co-location requirement. For general description of co-location requirements, refer to clause 4.12.
- The requirement for *BS type 2-O* is verified by an EIRP measurement at a direction corresponding to the OTA peak directions set reference beam direction pair (D.8) for the beam identifier (D.3) which provides the highest intended EIRP.

## 6.5.2.4.2 Procedure

### 6.5.2.4.2.1 General procedure

- 1) Place the BS at the positioner.
- 2) Align the manufacturer declared coordinate system orientation (D.2) of the BS with the test system.

### 6.5.2.4.2.2 BS type 1-O

- 3) Set the BS in the direction of the declared beam peak direction of the beam direction pair, for the beam to be tested.
- 4) Place the *co-location test antenna* as specified in clause 4.12.
- 5) Configure the beam peak direction of the BS according to the declared beam direction pair.
- 6) Set the BS to transmit according to the applicable test configuration in clause 4.8 using the corresponding test models or set of physical channels in clause 4.9.2.

For a BS declared to be capable of multi-carrier and/or CA operation, use the applicable test signal configuration and corresponding power setting specified in clauses 4.7.2 and 4.8 using the corresponding test models or set of physical channels in clause 4.9.2 on all carriers configured.

- 7) Measure the mean power spectral density at the output(s) of co-location test antenna as power sum over two orthogonal polarizations over  $70/N$   $\mu\text{s}$  filtered with a square filter of bandwidth equal to the RF bandwidth of the BS centred on the central frequency of the RF bandwidth.  $70/N$   $\mu\text{s}$  average window centre is set from  $35/N$   $\mu\text{s}$  after end of one transmitter ON period +  $10$   $\mu\text{s}$  to  $35/N$   $\mu\text{s}$  before start of next transmitter ON period -  $10$   $\mu\text{s}$ .  $N = \text{SCS}/15$ , where SCS is Sub Carrier Spacing in kHz.
- 8) For an BS supporting contiguous CA, measure the mean power spectral density at the output(s) of co-location test antenna as power sum over two orthogonal polarizations over  $70/N$   $\mu\text{s}$  filtered with a square filter of bandwidth equal to the *aggregated BS channel bandwidth*  $\text{BW}_{\text{Channel\_CA}}$  centred on  $(F_{\text{edge\_high}} + F_{\text{edge\_low}})/2$ .  $70/N$   $\mu\text{s}$  average window centre is set from  $35/N$   $\mu\text{s}$  after end of one transmitter ON period +  $10$   $\mu\text{s}$  to  $35/N$   $\mu\text{s}$  before start of next transmitter ON period -  $10$   $\mu\text{s}$ .  $N = \text{SCS}/15$ , where SCS is the smallest supported Sub Carrier Spacing in kHz in the *aggregated BS channel bandwidth*.

In addition, for a *multi-band RIB*, the following steps shall apply:

- 9) For a *multi-band RIB* and single band tests, repeat the steps above per involved band where single band test configurations and test models shall apply with no carrier activated in the other band.

### 6.5.2.4.2.3 BS type 2-O

- 3) Set the BS in the direction of the declared beam peak direction of the *beam direction pair*, for the beam to be tested.
- 4) Set the BS to transmit according to the applicable test configuration in clause 4.8 using the corresponding test model NR-FR2-TM1.1 and set of physical channels in clause 4.9.2.

For a BS declared to be capable of multi-carrier and/or CA operation, use the applicable test signal configuration and corresponding power setting specified in clauses 4.7.2 and 4.8 using the corresponding test model NR-FR2-TM1.1 and set of physical channels in clause 4.9.2 on all carriers configured.

- 5) Measure the mean EIRP spectral density as the power sum over two orthogonal polarizations over  $70/N$   $\mu\text{s}$  filtered with a square filter of bandwidth equal to the RF bandwidth of the NR BS centred on the central frequency of the RF bandwidth.  $70/N$   $\mu\text{s}$  average window centre is set from  $35/N$   $\mu\text{s}$  after end of one transmitter ON period +  $3$   $\mu\text{s}$  to  $35/N$   $\mu\text{s}$  before start of next transmitter ON period -  $3$   $\mu\text{s}$ .  $N = \text{SCS}/15$ , where SCS is Sub Carrier Spacing in kHz.

NOTE: Make sure that the measurement receiver is not overloaded.

- 6) For an NR BS supporting contiguous CA, measure the mean EIRP spectral density as the power sum over two orthogonal polarizations over  $70/N$   $\mu\text{s}$  filtered with a square filter of bandwidth equal to the *aggregated BS*

*channel bandwidth*  $BW_{\text{Channel\_CA}}$  centred on  $(F_{\text{edge\_high}} + F_{\text{edge\_low}})/2$ .  $70/N$   $\mu\text{s}$  average window centre is set from  $35/N$   $\mu\text{s}$  after end of one transmitter ON period + 3  $\mu\text{s}$  to  $35/N$   $\mu\text{s}$  before start of next transmitter ON period – 3  $\mu\text{s}$ .  $N = \text{SCS}/15$ , where SCS is the smallest supported Sub Carrier Spacing in kHz in the *aggregated BS channel bandwidth*.

## 6.5.2.5 Test requirements

### 6.5.2.5.1 BS type 1-0

The mean power spectral density measured according to clause 6.5.2.4.2 shall be less than -102.6 dBm/MHz for carrier frequency  $f \leq 3.0$  GHz.

The mean power spectral density measured according to clause 6.5.2.4.2 shall be less than -102.4 dBm/MHz for carrier frequency  $3.0 \text{ GHz} < f \leq 7.125$  GHz.

For *multi-band RIB*, the requirement is only applicable during the transmitter OFF period in all supported operating bands.

### 6.5.2.5.2 BS type 2-0

The measured mean EIRP spectral density according to clause 6.5.2.4.2 shall be less than  $-33.1 + P_{\text{rated,c,EIRP}} - P_{\text{rated,c,TRP}}$  dBm/MHz for carrier frequency  $24.15 \text{ GHz} < f \leq 29.5$  GHz, where  $P_{\text{rated,c,EIRP}}$  is the value declared for the *reference beam direction pair* (D.8) for the beam identifier (D.3) which provides the highest intended EIRP.

The measured mean EIRP spectral density according to clause 6.5.2.4.2 shall be less than  $-32.7 + P_{\text{rated,c,EIRP}} - P_{\text{rated,c,TRP}}$  dBm/MHz for carrier frequency  $37 \text{ GHz} < f \leq 43.5$  GHz, where  $P_{\text{rated,c,EIRP}}$  is the value declared for the *reference beam direction pair* (D.8) for the beam identifier (D.3) which provides the highest intended EIRP.

The measured mean EIRP spectral density according to clause 6.5.2.4.2 shall be less than  $-32.4 + P_{\text{rated,c,EIRP}} - P_{\text{rated,c,TRP}}$  dBm/MHz for carrier frequency  $43.5 \text{ GHz} < f \leq 48.2$  GHz, where  $P_{\text{rated,c,EIRP}}$  is the value declared for the *reference beam direction pair* (D.8) for the beam identifier (D.3) which provides the highest intended EIRP.

The measured mean EIRP spectral density according to clause 6.5.2.4.2 shall be less than  $-30.4 + P_{\text{rated,c,EIRP}} - P_{\text{rated,c,TRP}}$  dBm/MHz for carrier frequency  $52.6 \text{ GHz} \leq f \leq 71$  GHz, where  $P_{\text{rated,c,EIRP}}$  is the value declared for the *reference beam direction pair* (D.8) for the beam identifier (D.3) which provides the highest intended EIRP.

## 6.6 OTA transmitted signal quality

### 6.6.1 General

Unless otherwise stated, the requirements in clause 6.6 apply during the *transmitter ON period*.

### 6.6.2 OTA frequency error

#### 6.6.2.1 Definition and applicability

OTA frequency error is the measure of the difference between the actual BS transmit frequency and the assigned frequency. The same source shall be used for RF frequency and data clock generation.

OTA frequency error requirement is defined as a directional requirement at the RIB and shall be met within the OTA coverage range.

#### 6.6.2.2 Minimum Requirement

The minimum requirement for *BS type 1-0* is in TS 38.104 [2], clause 9.6.1.2.

The minimum requirement for *BS type 2-0* is in TS 38.104 [2], clause 9.6.1.3.



### 6.6.2.3 Test purpose

The test purpose is to verify that OTA frequency error is within the limit specified by the minimum requirement.

### 6.6.2.4 Method of test

Requirement is tested together with OTA modulation quality test, as described in clause 6.6.3.

#### 6.6.2.4.1 Initial conditions

Directions to be tested: OTA coverage range reference direction (D.35).

### 6.6.2.5 Test Requirements

The modulated carrier frequency of each NR carrier configured by the BS shall be accurate to within the accuracy range given in table 6.6.2.5-1 observed over 1 ms.

**Table 6.6.2.5-1: OTA frequency error test requirement for *BS type 1-O* and *BS type 2-O***

BS class	Accuracy
Wide Area BS	$\pm(0.05 \text{ ppm} + 12 \text{ Hz})$
Medium Range BS	$\pm(0.1 \text{ ppm} + 12 \text{ Hz})$
Local Area BS	$\pm(0.1 \text{ ppm} + 12 \text{ Hz})$

## 6.6.3 OTA modulation quality

### 6.6.3.1 Definition and applicability

OTA modulation quality is defined by the difference between the measured carrier signal and an ideal signal. Modulation quality can e.g. be expressed as Error Vector Magnitude (EVM). The Error Vector Magnitude is a measure of the difference between the ideal symbols and the measured symbols after the equalization. This difference is called the error vector.

OTA modulation quality requirement is defined as a directional requirement at the RIB and shall be met within the *OTA coverage range*.

### 6.6.3.2 Minimum Requirement

The minimum requirement for *BS type 1-O*, is in TS 38.104 [2], clause 9.6.2.2.

The minimum requirement for *BS type 2-O*, is in TS 38.104 [2], clause 9.6.2.3.

### 6.6.3.3 Test purpose

The test purpose is to verify that OTA modulation quality is within the limit specified by the minimum requirement.

### 6.6.3.4 Method of test

#### 6.6.3.4.1 Initial conditions

Test environment: Normal; see annex B.2.

RF channels to be tested for single carrier:

- B and T; see clause 4.9.1.

*Base station RF bandwidth* positions to be tested for multi-carrier and/or CA:

- $B_{\text{RFBW}}$  and  $T_{\text{RFBW}}$  in single-band operation, see clause 4.9.1;

- $B_{\text{RFBW}} T_{\text{RFBW}}$  and  $B'_{\text{RFBW}} T_{\text{RFBW}}$  in multi-band operation, see clause 4.9.1.

Directions to be tested:

- The OTA coverage range reference direction (D.35).
- The OTA coverage range maximum directions (D.36).

Polarizations to be tested: For dual polarized systems the requirement shall be tested and met for both polarizations.

#### 6.6.3.4.2 Procedure

- 1) Place the BS at the positioner.
- 2) Align the manufacturer declared coordinate system orientation (D.2) of the BS with the test system.
- 3) Orient the positioner (and BS) in order that the direction to be tested aligns with the test antenna.
- 4) Configure the beamforming settings of the BS according to the direction to be tested.
- 5) Set the BS to output according to the applicable test configuration in clause 4.8 using the corresponding test models or set of physical channels in clause 4.9.2.

For BS type 1-O declared to be capable of single carrier operation only, set the BS to transmit a signal according to:

- NR-FR1-TM 3.1b if 1024QAM is supported by BS without power back off, or
- NR-FR1-TM 3.1b at manufacturer's declared related output power if 1024QAM is supported by BS with power back off, and NR-FR1-TM3.1a if 256QAM is supported by BS without power back off, or
- NR-FR1-TM 3.1b at manufacturer's declared rated output power if 1024QAM is supported by BS with power back off, and NR-FR1-TM 3.1a at manufacturer's declared rated output power if 256QAM is supported by BS with power back off, and NR-FR1-TM3.1 at maximum power, or
  - NR-FR1-TM 3.1a if 1024QAM is not supported by BS and 256 QAM is supported by BS without power back off, or
  - NR-FR1-TM3.1a if 256QAM is supported by BS with power back off and 1024QAM is not supported, at manufacturer's declared rated output power ( $P_{\text{rated,c,EIRP}}$ ) and NR-FR1-TM3.1 at maximum power
  - or NR-FR1-TM3.1 if highest modulation order supported by BS is 64QAM
  - or NR-FR1-TM3.2 if highest modulation order supported by BS is 16QAM
  - or NR-FR1-TM3.3 if highest modulation order supported by BS is QPSK.

For BS type 1-O declared to be capable of multi-carrier and/or CA operation, set the BS to transmit according to the applicable test signal configuration and corresponding power setting specified in clauses 4.7.2 and 4.8 using the corresponding test models on all carriers configured:

- NR-FR1-TM 3.1b if 1024QAM is supported by BS without power back off, or,
  - NR-FR1-TM 3.1b at manufacturer's declared rated output power if 1024QAM is supported by BS with power back off, and NR-FR1-TM3.1a if 256QAM is supported by BS without power back off, or
  - NR-FR1-TM 3.1b at manufacturer's declared rated output power if 1024QAM is supported by BS with power back off and NR-FR1-TM3.1a at manufacturer's declared rated output power if 256QAM is supported by BS with power back off, and NR-FR1-TM3.1 at maximum power, or
  - NR-FR1-TM 3.1a if 1024QAM is not supported by BS and 256QAM is supported by BS without power back off, or
  - NR-FR1-TM3.1a if 256QAM is supported by BS with power back off, at manufacturer's declared rated output power ( $P_{\text{rated,c,EIRP}}$ ) and NR-FR1-TM3.1 at maximum power, or
  - NR-FR1-TM3.1 if highest modulation order supported by BS is 64QAM, or

- NR-FR1-TM3.2 if highest modulation order supported by BS is 16QAM, or
- NR-FR1-TM3.3 if highest modulation order supported by BS is QPSK.

For *BS type 2-O* declared to be capable of single carrier operation only, set the BS to transmit a signal according to the applicable test signal configuration and corresponding power setting specified in clause 4.7.2 and 4.8 using the corresponding test models on all carriers configured:

- NR-FR2-TM3.1a with 256QAM signal if 256QAM is supported by BS without power back off, or
- NR-FR2-TM3.1a at manufacturer's declared rated output power if 256QAM is supported by BS with power back off, and NR-FR2-TM3.1 with highest modulation order supported without power back off, or
- NR-FR2-TM3.1 with 64QAM signal if 64QAM is supported by BS without power back off, or
- NR-FR2-TM 3.1 with highest modulation order without power back off if 64QAM is not supported by BS, or
- if 64 QAM is supported by BS with power back off, NR-FR2-TM 3.1 with 64QAM at manufacturer's declared rated output power ( $P_{\text{rated,c,EIRP}}$ ) and NR-FR2-TM3.1 with highest modulation order supported at maximum power.

For *BS type 2-O* declared to be capable of multi-carrier and/or CA operation, set the BS to transmit according to:

- NR-FR2-TM3.1a with 256QAM signal if 256QAM is supported by BS without power back off, or
- NR-FR2-TM3.1a at manufacturer's declared rated output power if 256QAM is supported by BS with power back off, and NR-FR2-TM3.1 at maximum power, or
- NR-FR2-TM3.1 with 64QAM signal if 64QAM is supported by BS without power back off, or
- NR-FR2-TM3.1 with highest modulation order supported without power back off if 64QAM is not supported by BS, or
- if 64QAM is supported by BS with power back off, NR-FR2-TM3.1 with 64QAM signal at manufacturer's declared rated output power ( $P_{\text{rated,c,EIRP}}$ ) and NR-FR2-TM3.1 with highest supported modulation order at maximum power

For NR-FR1-TM 3.1a and NR-FR2-TM 3.1, power back-off shall be applied if it is declared.

- 6) For each carrier, measure the EVM and frequency error as defined in annex L.
- 7) Repeat steps 5 and 6 for NR-FR1-TM2 if 256QAM and 1024 QAM is not supported by *BS type 1-O* or for NR-FR1-TM2a if 256QAM is supported by *BS type 1-O* and 1024 QAM is not supported by BS or for NR-FR1-TM2b if 1024QAM is supported. For NR-FR1-TM2, NR-FR1-TM2a and NR-FR1-TM2b, the OFDM symbol power (in the conformance direction) shall be at the lower limit of the dynamic range according to the test procedure in clause 6.4.3.4.2 and test requirements in clause 6.4.3.5.1.

Repeat steps 5 and 6 for NR-FR2-TM2 if 256QAM is not supported by *BS type 2-O* or for NR-FR2-TM2a if 256QAM is supported by *BS type 2-O*. For NR-FR2-TM2 and NR-FR1-TM2a the OFDM symbol power (in the conformance direction) shall be at the lower limit of the dynamic range according to the test procedure in clause 6.4.3.4.2 and test requirements in clause 6.4.3.5.2.

In addition, for multi-band RIB, the following steps shall apply:

- 8) For multi-band RIB and single band tests, repeat the steps above per involved band where single band test configurations and test models shall apply with no carrier activated in the other band.

### 6.6.3.5 Test requirements

#### 6.6.3.5.1 *BS type 1-O*

For *BS type 1-O*, the EVM of each NR carrier for different modulation schemes on PDSCH shall be less than the limits in table 6.6.3.5.1-1.

**Table 6.6.3.5.1-1: EVM requirements for *BS type 1-O***

Modulation scheme for PDSCH	Required EVM (%)
QPSK	18.5
16QAM	13.5
64QAM	9
256QAM	4.5
1024QAM	3.5 % <sup>1</sup>
	3.8 % <sup>2</sup>
NOTE 1: This requirement is applicable for frequencies equal to or below 4.2 GHz.	
NOTE 2: This requirement is applicable for frequencies above 4.2 GHz.	

EVM shall be evaluated for each NR carrier over all allocated resource blocks and downlink slots. Different modulation schemes listed in table 6.6.3.5.1-1 shall be considered for rank 1.

For NR, for all bandwidths, the EVM measurement shall be performed for each NR carrier over all allocated resource blocks and downlink slots within 10 ms measurement periods. The boundaries of the EVM measurement periods need not be aligned with radio frame boundaries.

Table 6.6.3.5.1-2, 6.6.3.5.1-3, 6.6.3.5.1-4 below specify the EVM window length ( $W$ ) for normal CP for *BS type 1-O*.

**Table 6.6.3.5.1-2: EVM window length for normal CP, FR1, 15 kHz SCS**

Channel bandwidth (MHz)	FFT size	Cyclic prefix length for symbols 1-6 and 8-13 in FFT samples	EVM window length $W$	Ratio of $W$ to total CP length for symbols 1-6 and 8-13 (Note) (%)
5	512	36	14	40
10	1024	72	28	40
15	1536	108	44	40
20	2048	144	58	40
25	2048	144	72	50
30	3072	216	108	50
35	3072	216	108	50
40	4096	288	144	50
45	4096	288	144	50
50	4096	288	144	50
NOTE: These percentages are informative and apply to a slot's symbols 1 to 6 and 8 to 13. Symbols 0 and 7 have a longer CP and therefore a lower percentage.				

Table 6.6.3.5.1-3: EVM window length for normal CP, FR1, 30 kHz SCS

Channel bandwidth (MHz)	FFT size	Cyclic prefix length for symbols 1-13 in FFT samples	EVM window length $W$	Ratio of $W$ to total CP length for symbols 1-13 (Note) (%)
5	256	18	8	40
10	512	36	14	40
15	768	54	22	40
20	1024	72	28	40
25	1024	72	36	50
30	1536	108	54	50
35	1536	108	54	50
40	2048	144	72	50
45	2048	144	72	50
50	2048	144	72	50
60	3072	216	130	60
70	3072	216	130	60
80	4096	288	172	60
90	4096	288	172	60
100	4096	288	172	60

NOTE: These percentages are informative and apply to a slot's symbols 1 through 13. Symbol 0 has a longer CP and therefore a lower percentage.

Table 6.6.3.5.1-4: EVM window length for normal CP for NR, FR1, 60 kHz SCS

Channel bandwidth (MHz)	FFT size	Cyclic prefix length in FFT samples	EVM window length $W$	Ratio of $W$ to total CP (Note) (%)
10	256	18	8	40
15	384	27	11	40
20	512	36	14	40
25	512	36	18	50
30	768	54	26	50
35	768	54	26	50
40	1024	72	36	50
45	1024	72	36	50
50	1024	72	36	50
60	1536	108	64	60
70	1536	108	64	60
80	2048	144	86	60
90	2048	144	86	60
100	2048	144	86	60

NOTE: These percentages are informative and apply to all OFDM symbols within subframe except for symbol 0 of slot 0 and slot 2. Symbol 0 of slot 0 and slot 2 may have a longer CP and therefore a lower percentage.

### 6.6.3.5.2 BS type 2-O

For *BS type 2-O*, the EVM of each NR carrier for different modulation schemes on PDSCH shall be less than the limits in table 6.6.3.5.2-1 for FR2-1 and table 6.6.3.5.2-1a for FR2-2.

Table 6.6.3.5.2-1: EVM requirements for BS type 2-O for FR2-1

Modulation scheme for PDSCH	Required EVM (%)
QPSK	18.5
16QAM	13.5
64QAM	9
256QAM	4.5

**Table 6.6.3.5.2-1a: EVM requirements for *BS type 2-O* for *FR2-2***

Modulation scheme for PDSCH	Required EVM (%)
QPSK	[18.5]
16QAM	[13.5]
64QAM	[9.0]

EVM requirements shall apply for each NR carrier over all allocated resource blocks and downlink slots. PT-RS should be configured for localized setting for every fourth symbol for every second RB. Different modulation schemes listed in table 6.6.3.5.2-1 and table 6.6.3.5.2-1a shall be considered for rank 1.

For FR2-1, for all bandwidths, the EVM measurement shall be performed for each NR carrier over all allocated resource blocks and downlink slots within 10 ms measurement periods. The boundaries of the EVM measurement periods need not be aligned with radio frame boundaries.

For FR2-2, for all bandwidths, the EVM measurement shall be performed for each NR carrier over all allocated resource blocks and downlink slots within 80 slots measurement periods. The boundaries of the EVM measurement periods need not be aligned with radio frame boundaries.

Table 6.6.3.5.2-2, 6.6.3.5.2-3, 6.6.3.5.2-4, and 6.6.3.5.2-5 below specify the EVM window length ( $W$ ) for normal CP for *BS type 2-O*.

**Table 6.6.3.5.2-2: EVM window length for normal CP, FR2-1, 60 kHz SCS**

Channel bandwidth (MHz)	FFT size	Cyclic prefix length in FFT samples	EVM window length $W$	Ratio of $W$ to total CP length (Note) (%)
50	1024	72	36	50
100	2048	144	72	50
200	4096	288	144	50

NOTE: These percentages are informative and apply to all OFDM symbols within subframe except for symbol 0 of slot 0 and slot 2. Symbol 0 of slot 0 and slot 2 may have a longer CP and therefore a lower percentage.

**Table 6.6.3.5.2-3: EVM window length for normal CP, FR2, 120 kHz SCS**

Channel bandwidth (MHz)	FFT size	Cyclic prefix length in FFT samples	EVM window length $W$	Ratio of $W$ to total CP length (Note) (%)
50	512	36	18	50
100	1024	72	36	50
200	2048	144	72	50
400	4096	288	144	50

NOTE: These percentages are informative and apply to all OFDM symbols within subframe except for symbol 0 of slot 0 and slot 4. Symbol 0 of slot 0 and slot 4 may have a longer CP and therefore a lower percentage.

**Table 6.6.3.5.2-4: EVM window length for normal CP, FR2-2, 480 kHz SCS**

Channel bandwidth (MHz)	FFT size	Cyclic prefix length in FFT samples	EVM window length $W$	Ratio of $W$ to total CP length (Note) (%)
400	1024	72	36	50
800	2048	144	72	50
1600	4096	288	144	50

NOTE: These percentages are informative and apply to all OFDM symbols within subframe except for symbol 0 of slot 0 and slot 16. Symbol 0 of slot 0 and slot 16 may have a longer CP and therefore a lower percentage.

Table 6.6.3.5.2-5: EVM window length for normal CP, FR2-2, 960 kHz SCS

Channel bandwidth (MHz)	FFT size	Cyclic prefix length in FFT samples	EVM window length $W$	Ratio of $W$ to total CP length (Note) (%)
400	512	36	18	50
800	1024	72	36	50
1600	2048	144	72	50
2000	2048	144	72	50

NOTE: These percentages are informative and apply to all OFDM symbols within subframe except for symbol 0 of slot 0 and slot 32. Symbol 0 of slot 0 and slot 32 may have a longer CP and therefore a lower percentage.

## 6.6.4 OTA time alignment error

### 6.6.4.1 Definition and applicability

This requirement shall apply to frame timing in MIMO transmission, carrier aggregation and their combinations.

Frames of the NR signals present in the radiated domain are not perfectly aligned in time. In relation to each other, the RF signals present in the radiated domain may experience certain timing differences.

For a specific set of signals/transmitter configuration/transmission mode, the OTA Time Alignment Error (OTA TAE) is defined as the largest timing difference between any two different NR signals. The OTA time alignment error requirement is defined as a *directional requirement* at the RIB and shall be met within the *OTA coverage range*.

### 6.6.4.2 Minimum requirement

The minimum requirement for *BS type 1-O* is in TS 38.104 [2], clause 9.6.3.2.

The minimum requirement for *BS type 2-O* is in TS 38.104 [2], clause 9.6.3.3.

### 6.6.4.3 Test purpose

To verify that the OTA time alignment error is within the limit specified by the minimum requirement.

### 6.6.4.4 Method of test

#### 6.6.4.4.1 Initial conditions

Test environment: Normal; see annex B.2.

RF channels to be tested for single carrier: M; see clause 4.9.1.

*Base Station RF Bandwidth* positions to be tested for multi-carrier and/or CA:

- $M_{\text{RFBW}}$  in single-band operation, see clause 4.9.1;
- $B_{\text{RFBW}} \cdot T_{\text{RFBW}}$  and  $B'_{\text{RFBW}} \cdot T_{\text{RFBW}}$  in multi-band operation, see clause 4.9.1.

Directions to be tested: OTA coverage range reference direction (D.35).

Polarizations to be tested: For dual polarized systems the requirement shall be tested and met considering both polarisations. If the measurement antenna does not support dual polarization, time alignment error shall be measured under the condition that measurement antenna is aligned between the BS polarisations such that it receives half the power from each polarisation.

#### 6.6.4.4.2 Procedure

- 1) Place the BS at the positioner.
- 2) Align the manufacturer declared coordinate system orientation (D.2) of the BS with the test system.

- 3) Orient the positioner (and BS) in order that the direction to be tested aligns with the test antenna.
- 4) Configure the beamforming settings of the BS according to the direction of the testing.
- 5) Set the *BS type 1-O* to transmit NR-FR1-TM1.1 or any DL signal using MIMO transmission or carrier aggregation, using the configuration with the minimum number of cells and reference signals.

Set the *BS type 2-O* to transmit NR-FR2-TM 1.1 or any DL signal using MIMO transmission or carrier aggregation, using the configuration with the minimum number of cells and reference signals.

NOTE: For MIMO transmission, different ports may be configured in NR-FR1-TM1.1 and NR-FR2-TM 1.1 (using DMRS ports  $p = 1000$  and  $1001$  with CDM).

For a BS declared to be capable of single carrier operation only, set the BS to transmit according to the applicable test configuration in clause 4.8 using the corresponding test model at manufacturer's declared rated output power,  $P_{\text{rated,c,TRP}}$ .

If the BS supports intra band contiguous or non-contiguous Carrier Aggregation set the BS to transmit using the applicable test configuration and corresponding power setting specified in clauses 4.7.2 and 4.8.

If the BS supports inter band carrier aggregation set the BS to transmit, for each band, a single carrier or all carriers, using the applicable test configuration and corresponding power setting specified in clauses 4.7.2 and 4.8.

For *BS type 1-O* declared to be capable of multi-carrier operation, set the BS to transmit according to the applicable test signal configuration and corresponding power setting specified in clauses 4.7.2 and 4.8 using the corresponding test model on all carriers configured.

For *BS type 2-O* declared to be capable of multi-carrier operation, set the BS to transmit according to the applicable test signal configuration and corresponding power setting specified in clauses 4.7.2 and 4.8 using the corresponding test model on all carriers configured.

- 6) Measure the time alignment error between the different reference symbols on different beams on the carrier(s).

In addition, for a multi-band RIB, the following steps shall apply:

- 7) For a multi-band RIB and single band tests, repeat the steps above per involved band where single band test configurations and test models shall apply with no carrier activated in the other band.

## 6.6.4.5 Test Requirement

### 6.6.4.5.1 *BS type 1-O*

For MIMO transmission, at each carrier frequency, OTA TAE shall not exceed 90 ns.

For intra-band contiguous carrier aggregation, with or without MIMO, OTA TAE shall not exceed 285 ns.

For intra-band non-contiguous carrier aggregation, with or without MIMO, OTA TAE shall not exceed 3.025  $\mu\text{s}$ .

For inter-band carrier aggregation, with or without MIMO, OTA TAE shall not exceed 3.025  $\mu\text{s}$ .

The TAE requirement does not apply to ATG BS.

### 6.6.4.5.2 *BS type 2-O*

The minimum requirement for TAE is given in Table 6.6.4.5.2-1.



Table 6.6.4.5.2-1: TAE requirements for *BS type 2-O*

Requirement	TAE		
	60, 120 kHz SCS (ns)	480 kHz SCS (ns)	960 kHz SCS (ns)
MIMO transmission	90	57.5	57.5
<i>intra-band contiguous carrier aggregation</i> , with or without MIMO	155	57.5	57.5
<i>intra-band non-contiguous carrier aggregation</i> , with or without MIMO (Note)	285	N/A	N/A
<i>inter-band carrier aggregation</i> , with or without MIMO	3025	3025	3025
NOTE: <i>Intra-band non-contiguous carrier aggregation</i> is not supported for FR2-2 in this release.			

## 6.7 OTA unwanted emissions

### 6.7.1 General

OTA unwanted emissions consist of so-called out-of-band emissions and spurious emissions according to ITU definitions ITU-R SM.329 [5]. In ITU terminology, out of band emissions are unwanted emissions immediately outside the *BS channel bandwidth* resulting from the modulation process and non-linearity in the transmitter but excluding spurious emissions. Spurious emissions are emissions which are caused by unwanted transmitter effects such as harmonics emission, parasitic emission, intermodulation products and frequency conversion products, but exclude out of band emissions.

The OTA out-of-band emissions requirement for the *BS type 1-O* and *BS type 2-O* transmitter is specified both in terms of Adjacent Channel Leakage power Ratio (ACLR) and operating band unwanted emissions (OBUE). The OTA Operating band unwanted emissions define all unwanted emissions in each supported downlink operating band plus the frequency ranges  $\Delta f_{\text{OBUE}}$  above and  $\Delta f_{\text{OBUE}}$  below each band. OTA Unwanted emissions outside of this frequency range are limited by an OTA spurious emissions requirement.

The maximum offset of the operating band unwanted emissions mask from the operating band edge is  $\Delta f_{\text{OBUE}}$ . The value of  $\Delta f_{\text{OBUE}}$  is defined in table 6.7.1-1 for *BS type 1-O* and *BS type 2-O* for the NR operating bands.

Table 6.7.1-1: Maximum offset  $\Delta f_{\text{OBUE}}$  outside the downlink operating band

BS type	Operating band characteristics	$\Delta f_{\text{OBUE}}$ (MHz)
BS type 1-O	$F_{\text{DL,high}} - F_{\text{DL,low}} < 100$ MHz	10
	$100 \text{ MHz} \leq F_{\text{DL,high}} - F_{\text{DL,low}} \leq 900$ MHz	40
	n104	100
BS type 2-O	$F_{\text{DL,high}} - F_{\text{DL,low}} \leq 4000$ MHz	1500
	$4000 < F_{\text{DL,high}} - F_{\text{DL,low}} \leq 14000$ MHz	3500

The OTA unwanted emission requirements are applied per cell for all the configurations. Requirements for OTA unwanted emissions are captured using TRP, *directional requirements* or co-location requirements as described per requirement.

There is in addition a requirement for OTA occupied bandwidth.

### 6.7.2 OTA occupied bandwidth

#### 6.7.2.1 Definition and applicability

The OTA occupied bandwidth is the width of a frequency band such that, below the lower and above the upper frequency limits, the mean powers emitted are each equal to a specified percentage  $\beta/2$  of the total mean transmitted power. See also recommendation ITU-R SM.328 [13].

The value of  $\beta/2$  shall be taken as 0.5%.

The OTA occupied bandwidth requirement applies during the *transmitter ON period* for a single transmitted carrier. The minimum requirement below may be applied regionally. There may also be regional requirements to declare the OTA occupied bandwidth according to the definition in the present clause.

The OTA occupied bandwidth is defined as a *directional requirement* and shall be met in the manufacturer's declared *OTA coverage range* at the RIB.

### 6.7.2.2 Minimum requirement

The minimum requirement for *BS type 1-O* and *BS type 2-O* is in TS 38.104 [2], clause 9.7.2.2.

### 6.7.2.3 Test purpose

The test purpose is to verify that the emission at the *RIB* does not occupy an excessive bandwidth for the service to be provided and is, therefore, not likely to create interference to other users of the spectrum beyond undue limits.

### 6.7.2.4 Method of test

#### 6.7.2.4.1 Initial conditions

Test environment: Normal, see annex B.2.

RF channels to be tested for single carrier: M; see clause 4.9.1.

Directions to be tested: OTA coverage range reference direction (D.35).

Beams to be tested: Declared beam with the highest intended EIRP for the narrowest intended beam corresponding to the smallest  $BeW\theta$ , or for the narrowest intended beam corresponding to the smallest  $BeW\phi$  (D.3, D.11).

*Aggregated BS channel bandwidth* positions to be tested for contiguous carrier aggregation:  $M_{BW\ Channel\ CA}$ ; see clause 4.9.1.

For a BS declared to be capable of single carrier operation, start transmission according to the applicable test configuration in clause 4.8 using the corresponding test model NR-FR1-TM1.1 for *BS type 1-O* or NR-FR2-TM1.1 for *BS type 2-O* in clause 4.9.2 at manufacturers declared rated carrier EIRP ( $P_{rated,c,EIRP}$ , D.11).

For a BS declared to be capable of contiguous carrier aggregation operation, set the base station to transmit according to NR-FR1-TM1.1 for *BS type 1-O* or NR-FR2-TM1.1 for *BS type 2-O* in clause 4.9.2 on all carriers configured using the applicable test configuration and corresponding power setting specified in clauses 4.7.2.3.1 and 4.8.

#### 6.7.2.4.2 Procedure

- 1) Place the BS at the positioner.
- 2) Align the manufacturer declared coordinate system orientation (D.2) of the BS with the test system.
- 3) Orient the positioner (and BS) in order that the direction to be tested aligns with the test antenna..
- 4) Configure the beam peak direction of the BS according to the declared beam direction pair.
- 5) Set the BS to transmit signal.
- 6) Measure the spectrum emission of the transmitted signal using at least the number of measurement points, and across a span, as listed in table 6.7.2.4.2-1, table 6.7.2.4.2-2, and table 6.7.2.4.2-3. The selected resolution bandwidth (RBW) filter of the analyser shall be 30 kHz or less.

NOTE: The detection mode of the spectrum analyzer will not have any effect on the result if the statistical properties of the out-of-OBW power are the same as those of the inside-OBW power. Both are expected to have the Rayleigh distribution of the amplitude of Gaussian noise. In any case where the statistics are not the same, though, the detection mode is power responding. There are at least two ways to be power responding. The spectrum analyser can be set to "sample" detection, with its video bandwidth setting at least three times its RBW setting. Or the analyser may be set to respond to the average of the power (root-mean-square of the voltage) across the measurement cell.

Table 6.7.2.4.2-1: Span and number of measurement points for OBW measurements for FR1

Bandwidth	BS channel bandwidth $BW_{Channel}$ (MHz)					Aggregated BS channel bandwidth $BW_{Channel\_CA}$ (MHz)
	5	10	15	20	> 20	> 20
Span (MHz)	10	20	30	40	$2 \times BW_{Channel}$	$2 \times BW_{Channel\_CA}$
Minimum number of measurement points	400	400	400	400	$\left\lceil \frac{2 \times BW_{Channel}}{100kHz} \right\rceil$	$\left\lceil \frac{2 \times BW_{Channel\_CA}}{100kHz} \right\rceil$

Table 6.7.2.4.2-2: Span and number of measurement points for OBW measurements for FR2-1

Bandwidth	BS channel bandwidth $BW_{Channel}$ (MHz)				Aggregated BS channel bandwidth $BW_{Channel\_CA}$ (MHz)
	50	100	200	400	> 50
Span (MHz)	$2 \times BW_{Channel}$				$2 \times BW_{Channel\_CA}$
Minimum number of measurement points	$\left\lceil \frac{2 \times BW_{Channel}}{200kHz} \right\rceil$				$\left\lceil \frac{2 \times BW_{Channel\_CA}}{200kHz} \right\rceil$

Table 6.7.2.4.2-3: Span and number of measurement points for OBW measurements for FR2-2

Bandwidth	BS channel bandwidth $BW_{Channel}$ (MHz)					Aggregated BS channel bandwidth $BW_{Channel\_CA}$ (MHz)	
	100	400	800	1600	2000	$\leq 400$	> 400
Span (MHz)	$2 \times BW_{Channel}$					$2 \times BW_{Channel\_CA}$	
Minimum number of measurement points	$\left\lceil \frac{2 \times BW_{Channel}}{200 \text{ kHz}} \right\rceil$		$\left\lceil \frac{2 \times BW_{Channel}}{800 \text{ kHz}} \right\rceil$			$\left\lceil \frac{2 \times BW_{Channel\_CA}}{200 \text{ kHz}} \right\rceil$	$\left\lceil \frac{2 \times BW_{Channel\_CA}}{800 \text{ kHz}} \right\rceil$

- 7) Compute the total of the EIRP,  $P_0$ , (in power units, not decibel units) of all the measurement cells in the measurement span. Compute  $P_1$ , the EIRP outside the occupied bandwidth on each side.  $P_1$  is half of the total EIRP outside the bandwidth.  $P_1$  is half of (100 % - (occupied percentage)) of  $P_0$ . Measure the EIRP for any two orthogonal polarizations (denoted  $p_1$  and  $p_2$ ) and calculate total radiated transmit power for particular *beam direction pair* as  $EIRP = EIRP_{p_1} + EIRP_{p_2}$ .
- 8) Determine the lowest frequency,  $f_1$ , for which the sum of all EIRP in the measurement cells from the beginning of the span to  $f_1$  exceeds  $P_1$ .
- 9) Determine the highest frequency,  $f_2$ , for which the sum of all EIRP in the measurement cells from the end of the span to  $f_2$  exceeds  $P_1$ .
- 10) Compute the OTA occupied bandwidth as  $f_2 - f_1$ .

In addition, for *multi-band RIB(s)*, the following steps shall apply:

- 11) For *multi-band RIBs* and single band tests, repeat the steps 6) - 10) above per involved band where single band test configurations and test models shall apply with no carriers activated in the other band.

## 6.7.2.5 Test requirement

### 6.7.2.5.1 *BS type 1-O*

The OTA occupied bandwidth for each NR carrier shall be less than the channel bandwidth as defined in TS 38.104 [2], table 5.3.5-1. For contiguous CA, the occupied bandwidth shall be less than or equal to the *aggregated BS channel bandwidth* as defined in TS 38.104 [2], clause 5.3A.

### 6.7.2.5.2 *BS type 2-O*

The OTA occupied bandwidth for each NR carrier shall be less than the channel bandwidth as defined in TS 38.104 [2], table 5.3.5-2. For contiguous CA, the occupied bandwidth shall be less than or equal to the *aggregated BS channel bandwidth* as defined in TS 38.104 [2], clause 5.3A.

## 6.7.3 OTA Adjacent Channel Leakage Power Ratio (ACLR)

### 6.7.3.1 Definition and applicability

OTA Adjacent Channel Leakage power Ratio (ACLR) is the ratio of the filtered mean power centred on the assigned channel frequency to the filtered mean power centred on an adjacent channel frequency. The measured power is TRP.

For both *BS type 1-O* and *BS type 2-O*, for a *RIB* operating in multi-carrier or contiguous CA, the OTA ACLR requirements in clause 6.7.3.2 apply to *BS channel bandwidths* of the outermost carrier.

For *BS type 1-O*, for a *RIB* operating in non-contiguous spectrum, the OTA ACLR requirements in clause 6.7.3.2 shall apply inside sub-block gaps for the frequency ranges defined in table 6.7.3.5.1-2a, while the CACLR requirement in clause 6.7.3.2 shall apply in *sub block gaps* for the frequency ranges defined in table 6.7.3.5.1-3. In addition, for a *multi-band RIB*, the ACLR requirement in clause 6.7.3.2 shall apply in *Inter RF Bandwidth gaps* for the frequency ranges defined in table 6.7.3.5.1-2a, while the CACLR requirement in clause 6.7.3.2 shall apply in *Inter RF Bandwidth gaps* for the frequency ranges defined in table 6.7.3.5.1-3.

For *BS type 2-O*, for a *RIB* operating in non-contiguous spectrum, the OTA ACLR requirements in clause 6.7.3.2 shall apply inside any sub-block gap for the frequency ranges defined in table 6.7.3.5.2-3, while the CACLR requirement in clause 6.6.3.2 shall apply in *sub block gaps* for the frequency ranges defined in table 6.7.3.5.2-3.

The requirement shall be applied per *RIB* during the *transmitter ON period*.

### 6.7.3.2 Minimum requirement

The minimum requirement for *BS type 1-O* is in TS 38.104 [2], clause 9.7.3.2.

The minimum requirement for *BS type 2-O* is in TS 38.104 [2], clause 9.7.3.3.

### 6.7.3.3 Test purpose

To verify that the OTA adjacent channel leakage ratio requirement shall be met as specified by the minimum requirement.

### 6.7.3.4 Method of test

#### 6.7.3.4.1 Initial conditions

Test environment: normal; see annex B.2.

RF channels to be tested for single carrier: B and T; see clause 4.9.1.

*Base Station RF Bandwidth* positions to be tested for multi-carrier and/or CA:

- $B_{\text{RFBW}}$  and  $T_{\text{RFBW}}$  in single-band operation, see clause 4.9.1;
- $B'_{\text{RFBW}}T'_{\text{RFBW}}$  and  $B'_{\text{RFBW}}T_{\text{RFBW}}$  in multi-band operation, see clause 4.9.1.

Directions to be tested: As the requirement is TRP the beam pattern(s) may be set up to optimise the TRP measurement procedure (see annex I).

#### 6.7.3.4.2 Procedure

The following procedure for measuring TRP is based on the directional power measurements as described in annex I. An alternative method to measure TRP is to use a characterized and calibrated reverberation chamber. If so, follow steps 1, 3, 4, 6, 8, 9, 10, 11, 12 and 13. When calibrated and operated within the guidance of 3GPP TR 37.941 [29] the measurement methods are applicable and selected depending on availability at the test facility.

- 1) Place the BS at the positioner.
- 2) Align the manufacturer declared coordinate system orientation (D.2) of the BS with the test system.
- 3) The measurement devices characteristics shall be:

measurement filter bandwidth: defined in clause 6.7.3.5.

detection mode: true RMS voltage or true power averaging.

The emission power should be averaged over an appropriate time duration to ensure the measurement is within the measurement uncertainty in Table 4.1.2.2-1 for FR1 and Table 4.1.2.2-2 for FR2.

- 4) For single carrier operation, set the BS to transmit according to the applicable test configuration in clause 4.8 using the corresponding test model(s) in clause 4.9.2 at manufacturers declared *rated carrier output power* ( $P_{\text{rated,c,TRP}}$ ).

For a BS declared to be capable of multi-carrier and/or CA operation use the applicable test signal configuration and corresponding power setting specified in clauses 4.7.2 and 4.8 using the corresponding test model(s) in clause 4.9.2 on all carriers configured.

- 5) Orient the positioner (and BS) in order that the direction to be tested aligns with the test antenna such that measurements to determine TRP can be performed (see annex I).
- 6) Measure the absolute power of the assigned channel frequency and the (adjacent channel frequency).
- 7) Repeat step 5-6 for all directions in the appropriated TRP measurement grid needed for  $\text{TRP}_{\text{Estimate}}$  (see annex I).
- 8) Calculate  $\text{TRP}_{\text{Estimate}}$  for the absolute total radiated power of the wanted channel and the adjacent channel using the measurements made in Step 7.
- 9) Calculate relative ACLR estimate.

NOTE 1: ACLR is calculated by the ratio of the absolute TRP of the assigned channel frequency and the absolute TRP of the adjacent frequency channel.

NOTE 2: For FR1 the measurement uncertainty of the reverberation chamber for the relative ACLR is higher than the measurement uncertainty in clause 4.1.2 the test requirements in table 6.7.3.5.1-1 shall be tightened following the procedure in clause 4.1.3.

10) Measure OTA ACLR for the frequency offsets both side of channel frequency as specified in table 6.7.3.5.1-1 for *BS type 1-O* or table 6.7.3.5.2-1 for *BS type 2-O* respectively. In multiple carrier case only offset frequencies below the lowest and above the highest carrier frequency used shall be measured.

11) For the OTA ACLR requirement applied inside sub-block gap for non-contiguous spectrum operation or inside *Inter RF Bandwidth gap* for multi-band operation:

- a) Measure OTA ACLR inside sub-block gap or *Inter RF Bandwidth gap*, if applicable.
- b) Measure OTA CACLR inside sub-block gap or *Inter RF Bandwidth gap*, if applicable.

12) Repeat the test with the channel set-up using NR- FR1-TM1.2 defined in clause 4.9.2 in TS 38.141-1 [3] for *BS type 1-O*.

In addition, for *multi-band RIB*, the following steps shall apply:

13) For *BS type 1-O* and *multi-band RIB* and single band tests, repeat the steps above per involved band where single band test configurations and test models shall apply with no carrier activated in the other band.

### 6.7.3.5 Test requirements

#### 6.7.3.5.1 *BS type 1-O*

For the OTA ACLR requirement either the OTA ACLR limits in tables 6.7.3.5.1-1/2a or the OTA ACLR absolute limits in table 6.7.3.5.1-2 shall apply, whichever is less stringent. The OTA CACLR limits in table 6.7.3.5.1-3 or the OTA CACLR absolute limits in table 6.7.3.5.1-3a shall apply, whichever is less stringent.

The CACLR in a sub-block gap and Inter RF Bandwidth gap is the ratio of:

- the sum of the filtered mean power centred on the assigned channel frequencies for the two carriers adjacent to each side of the sub-block gap or the Inter RF Bandwidth gap, and
- the filtered mean power centred on a frequency channel adjacent to one of the respective sub-block edges or Base Station RF Bandwidth edges.

The assumed filter for the adjacent channel frequency is defined in table 6.7.3.5.1-3 and the filters on the assigned channels are defined in table 6.7.3.5.1-4.

For operation in paired and unpaired spectrum, the OTA ACLR measurement result shall not be less than the OTA ACLR limit specified in table 6.7.3.5.1-1.

**Table 6.7.3.5.1-1: *BS type 1-O* ACLR limit**

<i>BS channel bandwidth of lowest/highest NR carrier transmitted</i> $BW_{\text{Channel}}$ (MHz)	<i>BS adjacent channel centre frequency offset below the lowest or above the highest carrier centre frequency transmitted</i>	<i>Assumed adjacent channel carrier (informative)</i>	<i>Filter on the adjacent channel frequency and corresponding filter bandwidth</i>	<i>OTA ACLR limit (0 – 3 GHz)</i>	<i>OTA ACLR limit (3 – 6 GHz)</i>	<i>OTA ACLR limit (6.0 – 7.125 GHz)</i>
5, 10, 15, 20, 25, 30, 35, 40, 45, 50, 60, 70, 80, 90, 100	$BW_{\text{Channel}}$	NR of same BW (Note 2)	Square ( $BW_{\text{Config}}$ )	44 dB	43.8 dB	36.8 dB
	$2 \times BW_{\text{Channel}}$	NR of same BW (Note 2)	Square ( $BW_{\text{Config}}$ )	44 dB	43.8 dB	36.8 dB
	$BW_{\text{Channel}}/2 + 2.5$ MHz	5 MHz E-UTRA	Square (4.5 MHz)	44 dB (Note 3)	43.8 dB (Note 3)	NA
	$BW_{\text{Channel}}/2 + 7.5$ MHz	5 MHz E-UTRA	Square (4.5 MHz)	44 dB (Note 3)	43.8 dB (Note 3)	NA

NOTE 1:  $BW_{\text{Channel}}$  and  $BW_{\text{Config}}$  are the *BS channel bandwidth* and transmission bandwidth configuration of the lowest/highest NR carrier transmitted on the assigned channel frequency.

NOTE 2: With SCS that provides largest transmission bandwidth configuration ( $BW_{\text{Config}}$ ).

NOTE 3: The requirements are applicable when the band is also defined for E-UTRA or UTRA.

The absolute total power measurement shall not exceed the OTA ACLR absolute limit specified in table 6.7.3.5.1-2.

**Table 6.7.3.5.1-2: *BS type 1-O* ACLR absolute limit**

<i>BS category / BS class</i>	<i>OTA ACLR absolute limit</i>
Category A Wide Area BS	-4 dBm/MHz
Category B Wide Area BS	-6 dBm/MHz
Medium Range BS	-16 dBm/MHz
Local Area BS	-23 dBm/MHz
NOTE 1: The test requirement is derived from the basic limit a scaling factor of 9 dB and any applicable TT.	
NOTE 2: Void	

For operation in non-contiguous spectrum or multiple bands, the OTA ACLR measurement result shall not be less than the OTA ACLR limit specified in table 6.7.3.5.1-2a.

Table 6.7.3.5.1-2a: *BS type 1-O ACLR limit in non-contiguous spectrum or multiple bands*

<i>BS channel bandwidth of NR carrier transmitted</i> <i>BW<sub>Channel</sub> adjacent to sub-block gap or inter RF Bandwidth gap (MHz)</i>	<i>Sub-block or Inter RF Bandwidth gap size (W<sub>gap</sub>) where the limit applies (MHz)</i>	<i>BS adjacent channel centre frequency offset below or above the sub-block or Base Station RF Bandwidth edge (inside the gap)</i>	<i>Assumed adjacent channel carrier</i>	<i>Filter on the adjacent channel frequency and corresponding filter bandwidth</i>	<i>OTA ACLR limit (0-3GHz)</i>	<i>OTA ACLR limit (3-6GHz)</i>	<i>OTA ACLR limit (6.0 – 7.125 GHz)</i>
5, 10, 15, 20	W <sub>gap</sub> ≥ 15 (Note 3) W <sub>gap</sub> ≥ 45 (Note 4)	2.5 MHz	5 MHz NR (Note 2)	Square (BW <sub>Config</sub> )	44 dB	43.8 dB	36.8 dB
	W <sub>gap</sub> ≥ 20 (Note 3) W <sub>gap</sub> ≥ 50 (Note 4)	7.5 MHz	5 MHz NR (Note 2)	Square (BW <sub>Config</sub> )	44 dB	43.8 dB	36.8 dB
25, 30, 35, 40, 45, 50, 60, 70, 80, 90, 100	W <sub>gap</sub> ≥ 60 (Note 4) W <sub>gap</sub> ≥ 30 (Note 3)	10 MHz	20 MHz NR (Note 2)	Square (BW <sub>Config</sub> )	44 dB	43.8 dB	36.8 dB
	W <sub>gap</sub> ≥ 80 (Note 4) W <sub>gap</sub> ≥ 50 (Note 3)	30 MHz	20 MHz NR (Note 2)	Square (BW <sub>Config</sub> )	44 dB	43.8 dB	36.8 dB

NOTE 1: BW<sub>Config</sub> is the transmission bandwidth configuration of the assumed adjacent channel carrier.  
NOTE 2: With SCS that provides largest transmission bandwidth configuration (BW<sub>Config</sub>).  
NOTE 3: Applicable in case the *BS channel bandwidth* of the NR carrier transmitted at the other edge of the gap is 5, 10, 15, 20 MHz.  
NOTE 4: Applicable in case the *BS channel bandwidth* of the NR carrier transmitted at the other edge of the gap is 25, 30, 35, 40, 45, 50, 60, 70, 80, 90, 100 MHz.

The OTA CA CLR measurement result shall not less than the OTA CA CLR limit specified in table 6.7.3.5.1-3.

Table 6.7.3.5.1-3: *BS type 1-O* CACLR limit

<i>BS channel bandwidth</i> of NR carrier transmitted $BW_{Channel}$ adjacent to <i>sub-block gap</i> or <i>inter RF Bandwidth gap</i> (MHz)	Sub-block or Inter RF Bandwidth gap size ( $W_{gap}$ ) where the limit applies (MHz)	BS adjacent channel centre frequency offset below or above the sub-block or Base Station RF Bandwidth edge (inside the gap)	Assumed adjacent channel carrier	Filter on the adjacent channel frequency and corresponding filter bandwidth	OTA CACLR limit (0-3 GHz)	OTA CACLR limit (3-6 GHz)	OTA CACLR limit (6.0 – 7.125 GHz)
5, 10, 15, 20	$5 \leq W_{gap} < 15$ (Note 3) $5 \leq W_{gap} < 45$ (Note 4)	2.5 MHz	5 MHz NR (Note 2)	Square ( $BW_{Config}$ )	44 dB	43.8 dB	36.8dB
	$10 < W_{gap} < 20$ (Note 3) $10 \leq W_{gap} < 50$ (Note 4)	7.5 MHz	5 MHz NR (Note 2)	Square ( $BW_{Config}$ )	44 dB	43.8 dB	36.8dB
25, 30, 35, 40, 45, 50, 60, 70, 80,90, 100	$20 \leq W_{gap} < 60$ (Note 4) $20 \leq W_{gap} < 30$ (Note 3)	10 MHz	20 MHz NR (Note 2)	Square ( $BW_{Config}$ )	44 dB	43.8 dB	36.8dB
	$40 < W_{gap} < 80$ (Note 4) $40 \leq W_{gap} < 50$ (Note 3)	30 MHz	20 MHz NR (Note 2)	Square ( $BW_{Config}$ )	44 dB	43.8 dB	36.8dB

NOTE 1:  $BW_{Config}$  is the transmission bandwidth configuration of the assumed adjacent channel carrier.  
NOTE 2: With SCS that provides largest transmission bandwidth configuration ( $BW_{Config}$ ).  
NOTE 3: Applicable in case the *BS channel bandwidth* of the NR carrier transmitted at the other edge of the gap is 5, 10, 15, 20 MHz.  
NOTE 4: Applicable in case the *BS channel bandwidth* of the NR carrier transmitted at the other edge of the gap is 25, 30, 35, 40, 45, 50, 60, 70, 80, 90, 100 MHz.

The absolute total power measurement shall not exceed the OTA CACLR absolute limit specified in table 6.7.3.5.1-3a.

Table 6.7.3.5.1-3a: *BS type 1-O* CACLR absolute limit

BS category / BS class	OTA CACLR absolute limit
Category A Wide Area BS	-4 dBm/MHz
Category B Wide Area BS	-6 dBm/MHz
Medium Range BS	-16 dBm/MHz
Local Area BS	-23 dBm/MHz

NOTE 1: The test requirement is derived from the basic limit a scaling factor of 9 dB and any applicable TT.  
NOTE 2: Void

Table 6.7.3.5.1-4: Filter parameters for the assigned channel

RAT of the carrier adjacent to the sub-block or Inter RF Bandwidth gap	Filter on the assigned channel frequency and corresponding filter bandwidth
NR	NR of same BW with SCS that provides largest transmission bandwidth configuration

### 6.7.3.5.2 *BS type 2-O*

For the OTA ACLR requirement either the OTA ACLR limits in tables 6.7.3.5.2-1/3 or the OTA ACLR absolute limits in table 6.7.3.5.2-2 shall apply, whichever is less stringent. The OTA CACLR limits in table 6.7.3.5.2-4 or the OTA CACLR absolute limits in table 6.7.3.5.2-4a shall apply, whichever is less stringent.

The CACLR in a sub-block gap is the ratio of:



- a) the sum of the filtered mean power centred on the assigned channel frequencies for the two carriers adjacent to each side of the sub-block gap, and
- b) the filtered mean power centred on a frequency channel adjacent to one of the respective sub-block edges.

The assumed filter for the adjacent channel frequency is defined in table 6.7.3.5.2-4 and the filters on the assigned channels are defined in table 6.7.3.5.2-5.

The OTA ACLR measurement result shall not be less than the OTA ACLR limit specified in table 6.7.3.5.2-1.

**Table 6.7.3.5.2-1: BS type 2-O ACLR limit**

<b>BS channel bandwidth of lowest/highest NR carrier transmitted</b> <b>BW<sub>Channel</sub></b> <b>(MHz)</b>	<b>BS adjacent channel centre frequency offset below the lowest or above the highest carrier centre frequency transmitted</b>	<b>Assumed adjacent channel carrier</b>	<b>Filter on the adjacent channel frequency and corresponding filter bandwidth</b>	<b>OTA ACLR limit (dB)</b>
50, 100, 200, 400, 800, 1600, 2000	BW <sub>Channel</sub>	NR of same BW (Note 2)	Square (BW <sub>Config</sub> )	25.7 (Note 3) 23.4 (Note 4) 23.2 (Note 5) 19.4 (Note 6)
NOTE 1: BW <sub>Channel</sub> and BW <sub>Config</sub> are the BS channel bandwidth and transmission bandwidth configuration of the lowest/highest NR carrier transmitted on the assigned channel frequency. NOTE 2: With SCS that provides largest transmission bandwidth configuration (BW <sub>Config</sub> ). NOTE 3: Applicable to bands defined within the frequency spectrum range of 24.25 – 33.4 GHz. NOTE 4: Applicable to bands defined within the frequency spectrum range of 37 – 43.5 GHz. NOTE 5: Applicable to bands defined within the frequency spectrum range of 43.5 – 48.2 GHz. NOTE 6: Applicable to bands defined within the frequency spectrum range of 52.6 – 71 GHz.				

The absolute total power measurement shall not exceed the OTA ACLR absolute limit specified in table 6.7.3.5.2-2

**Table 6.7.3.5.2-2: BS type 2-O ACLR absolute limit**

<b>BS class</b>	<b>ACLR absolute limit (Note 1)</b>	<b>ACLR absolute limit (Note 2)</b>	<b>ACLR absolute limit (Note 3)</b>
Wide area BS	-10.3 dBm/MHz	-10.1 dBm/MHz	-8.3 dBm/MHz
Medium range BS	-17.3 dBm/MHz	-17.1 dBm/MHz	-15.3 dBm/MHz
Local area BS	-17.3 dBm/MHz	-17.1 dBm/MHz	-15.3 dBm/MHz
NOTE 1: Applicable to bands defined within the frequency spectrum range of 24.25 – 43.5 GHz NOTE 2: Applicable to bands defined within the frequency spectrum range of 43.5 – 48.2 GHz. NOTE 3: Applicable to bands defined within the frequency spectrum range of 52.6 – 71 GHz.			

For operation in non-contiguous spectrum, the OTA ACLR measurement result shall not be less than the OTA ACLR limit specified in table 6.7.3.5.2-3.

Table 6.7.3.5.2-3: *BS type 2-O ACLR limit in non-contiguous spectrum*

<i>BS channel bandwidth of NR carrier transmitted adjacent to sub-block gap (MHz)</i>	<i>Sub-block gap size (W<sub>gap</sub>) where the limit applies (MHz)</i>	<i>BS adjacent channel centre frequency offset below or above the sub-block edge (inside the gap)</i>	<i>Assumed adjacent channel carrier</i>	<i>Filter on the adjacent channel frequency and corresponding filter bandwidth</i>	<i>OTA ACLR limit (MHz)</i>
50, 100	W <sub>gap</sub> ≥ 100 (Note 5) W <sub>gap</sub> ≥ 250 (Note 6)	25 MHz	50 MHz NR (Note 2)	Square (BW <sub>Config</sub> )	25.7 (Note 3) 23.4 (Note 4) 23.2 (Note 7)
200, 400	W <sub>gap</sub> ≥ 400 (Note 6) W <sub>gap</sub> ≥ 250 (Note 5)	100 MHz	200 MHz NR (Note 2)	Square (BW <sub>Config</sub> )	25.7 (Note 3) 23.4 (Note 4) 23.2 (Note 7)

NOTE 1: BW<sub>Config</sub> is the transmission bandwidth configuration of the assumed adjacent channel carrier.  
NOTE 2: With SCS that provides largest transmission bandwidth configuration (BW<sub>Config</sub>).  
NOTE 3: Applicable to bands defined within the frequency spectrum range of 24.24 – 33.4 GHz.  
NOTE 4: Applicable to bands defined within the frequency spectrum range of 37 – 43.5 GHz.  
NOTE 5: Applicable in case the *BS channel bandwidth* of the NR carrier transmitted at the other edge of the gap is 50 or 100 MHz.  
NOTE 6: Applicable in case the *BS channel bandwidth* of the NR carrier transmitted at the other edge of the gap is 200 or 400 MHz.  
NOTE 7: Applicable to bands defined within the frequency spectrum range of 43.5 – 48.2 GHz.

For operation in non-contiguous spectrum, the CACLR for carriers located on either side of the sub-block gap shall be less than the value specified in table 6.7.3.5.2-4.

Table 6.7.3.5.2-4: *BS type 2-O CACLR limit in non-contiguous spectrum*

<i>BS channel bandwidth of NR carrier transmitted adjacent to sub-block gap (MHz)</i>	<i>Sub-block gap size (W<sub>gap</sub>) where the limit applies (MHz)</i>	<i>BS adjacent channel centre frequency offset below or above the sub-block edge (inside the gap)</i>	<i>Assumed adjacent channel carrier</i>	<i>Filter on the adjacent channel frequency and corresponding filter bandwidth</i>	<i>OTA CACLR limit (dB)</i>
50, 100	50 ≤ W <sub>gap</sub> < 100 (Note 5) 50 ≤ W <sub>gap</sub> < 250 (Note 6)	25 MHz	50 MHz NR (Note 2)	Square (BW <sub>Config</sub> )	25.7 (Note 3) 23.4 (Note 4) 23.2 (Note 7)
200, 400	200 ≤ W <sub>gap</sub> < 400 (Note 6) 200 ≤ W <sub>gap</sub> < 250 (Note 5)	100 MHz	200 MHz NR (Note 2)	Square (BW <sub>Config</sub> )	25.7 (Note 3) 23.4 (Note 4) 23.2 (Note 7)

NOTE 1: BW<sub>Config</sub> is the transmission bandwidth configuration of the assumed adjacent channel carrier.  
NOTE 2: With SCS that provides largest transmission bandwidth configuration (BW<sub>Config</sub>).  
NOTE 3: Applicable to bands defined within the frequency spectrum range of 24.24 – 33.4 GHz.  
NOTE 4: Applicable to bands defined within the frequency spectrum range of 37 – 43.5 GHz.  
NOTE 5: Applicable in case the *BS channel bandwidth* of the NR carrier transmitted at the other edge of the gap is 50 or 100 MHz.  
NOTE 6: Applicable in case the *BS channel bandwidth* of the NR carrier transmitted at the other edge of the gap is 200 or 400 MHz.  
NOTE 7: Applicable to bands defined within the frequency spectrum range of 43.5 – 48.2 GHz.

The absolute total power measurement shall not exceed the OTA CACLR absolute limit specified in table 6.7.3.5.2-4a.

**Table 6.7.3.5.2-4a: BS type 2-O CACLR absolute limit**

BS class	CACLR absolute limit (Note 1)	ACLR absolute limit (Note 2)
Wide area BS	-10.3 dBm/MHz	-10.1 dBm/MHz
Medium range BS	-17.3 dBm/MHz	-17.1 dBm/MHz
Local area BS	-17.3 dBm/MHz	-17.1 dBm/MHz
NOTE 1: Applicable to bands defined within the frequency spectrum range of 24.25 – 43.5 GHz		
NOTE 2: Applicable to bands defined within the frequency spectrum range of 43.5 – 48.2 GHz		

**Table 6.7.3.5.2-5: Filter parameters for the assigned channel**

RAT of the carrier adjacent to the sub-block gap	Filter on the assigned channel frequency and corresponding filter bandwidth
NR	NR of same BW with SCS that provides largest transmission bandwidth configuration

## 6.7.4 OTA operating band unwanted emissions

### 6.7.4.1 Definition and applicability

The OTA limits for operating band unwanted emissions are specified as TRP per RIB, unless otherwise stated.

For *BS type 1-O*, for a *RIB* operating in multi-carrier or contiguous CA, the requirements apply to *BS channel bandwidths* of the outermost carrier. In addition, for a *RIB* operating in non-contiguous spectrum, the requirements shall apply inside any sub-block gap. In addition, for a *multi-band RIB*, the requirements shall apply inside any Inter RF Bandwidth gap.

For *BS type 2-O*, for a *RIB* operating in multi-carrier or contiguous CA, the requirements apply to the frequencies starting from the edge of the *contiguous transmission bandwidth*. In addition, for a *RIB* operating in non-contiguous spectrum, the requirements apply inside any sub-block gap.

### 6.7.4.2 Minimum requirement

The minimum requirement for *BS type 1-O* is defined in TS 38.104 [2], clause 9.7.4.2.

The minimum requirement for *BS type 2-O* is defined in TS 38.104 [2], clause 9.7.4.3.

### 6.7.4.3 Test purpose

This test measures the emissions of the BS, close to the assigned channel bandwidth of the wanted signal, while the BS is in operation.

### 6.7.4.4 Method of test

#### 6.7.4.4.1 Initial conditions

Test environment: normal; see annex B.2.

RF channels to be tested for single carrier: B, M and T; see clause 4.9.1.

*Base Station RF Bandwidth* positions to be tested for multi-carrier and/or CA:

- $B_{\text{RFBW}}$ ,  $M_{\text{RFBW}}$  and  $T_{\text{RFBW}}$  in single-band operation, see clause 4.9.1;
- $B'_{\text{RFBW}}T_{\text{RFBW}}$  and  $B_{\text{RFBW}}T_{\text{RFBW}}$  in multi-band operation, see clause 4.9.1.

Directions to be tested: As the requirement is TRP the beam pattern(s) may be set up to optimise the TRP measurement procedure (see annex I).

#### 6.7.4.4.2 Procedure

The following procedure for measuring TRP is based on the directional power measurements as described in annex I. An alternative method to measure TRP is to use a characterized and calibrated reverberation chamber. If so, follow steps 1, 3, 4, 6 and 9. When calibrated and operated within the guidance of 3GPP TR 37.941 [29] the measurement methods are applicable and selected depending on availability at the test facility.

- 1) Place the BS at the positioner.
- 2) Align the manufacturer declared coordinate system orientation (D.2) of the BS with the test system.
- 3) The measurement devices characteristics shall be:
  - measurement filter bandwidth: defined in clause 6.7.4.5.
  - detection mode: true RMS voltage or true power averaging.

As a general rule, the resolution bandwidth of the measuring equipment should be equal to the measurement bandwidth. However, to improve measurement accuracy, sensitivity, efficiency and avoiding e.g. carrier leakage, the resolution bandwidth may be smaller than the measurement bandwidth. When the resolution bandwidth is smaller than the measurement bandwidth, the result should be integrated over the measurement bandwidth in order to obtain the equivalent noise bandwidth of the measurement bandwidth.

The emission power should be averaged over an appropriate time duration to ensure the measurement is within the measurement uncertainty in Table 4.1.2.2-1 for FR1 and Table 4.1.2.2-2 for FR2.

- 4) For single carrier operation, set the BS to transmit according to the applicable test configuration in clause 4.8 using the corresponding test model(s) in clause 4.9.2 at manufacturers declared *rated carrier output power* ( $P_{\text{rated,c,TRP}}$ ).
 

For a BS declared to be capable of multi-carrier and/or CA operation, use the applicable test signal configuration and corresponding power setting specified in clause 4.7.2 and 4.8 using the corresponding test model(s) in clause 4.9.2 on all carriers configured.
- 5) Orient the positioner (and BS) in order that the direction to be tested aligns with the test antenna such that measurements to determine TRP can be performed (see annex I).
- 6) Sweep the centre frequency of the measurement filter in contiguous steps and measure emission power within the specified frequency ranges with the specified measurement bandwidth.
- 7) Repeat step 5-6 for all directions in the appropriated TRP measurement grid needed for  $\text{TRP}_{\text{Estimate}}$  (see annex I).
- 8) Calculate  $\text{TRP}_{\text{Estimate}}$  using the measurements made in step 6.
- 9) For *BS type 1-O* and *multi-band RIB* and single band tests, repeat the steps above per involved band where single band test configurations and test models shall apply with no carrier activated in the other band.

#### 6.7.4.5 Test requirements

##### 6.7.4.5.1 BS type 1-O

The emission measurement result shall not exceed the maximum levels specified in tables 6.7.4.5.1.1-1 to 6.7.4.5.1.5-3, where:

- $\Delta f$  is the separation between the channel edge frequency and the nominal -3dB point of the measuring filter closest to the carrier frequency.
- $f_{\text{offset}}$  is the separation between the channel edge frequency and the centre of the measuring filter.
- $f_{\text{offset}_{\text{max}}}$  is the offset to the frequency  $\Delta f_{\text{OBUe}}$  MHz outside the downlink operating band.
- $\Delta f_{\text{max}}$  is equal to  $f_{\text{offset}_{\text{max}}}$  minus half of the bandwidth of the measuring filter.

For a *multi-band RIB* inside any *Inter RF Bandwidth gaps* with  $W_{\text{gap}} < 2 \cdot \Delta f_{\text{OBUE}}$ , emissions shall not exceed the cumulative sum of the test requirements specified at the *Base Station RF Bandwidth edges* on each side of the *Inter RF Bandwidth gap*. The test requirement for *Base Station RF Bandwidth edge* is specified in the tables 6.7.4.5.1.1-1 to 6.7.4.5.1.5-3 below, where in this case:

- $\Delta f$  is the separation between the *Base Station RF Bandwidth edge* frequency and the nominal -3 dB point of the measuring filter closest to the *Base Station RF Bandwidth edge*.
- $f_{\text{offset}}$  is the separation between the *Base Station RF Bandwidth edge* frequency and the centre of the measuring filter.
- $f_{\text{offset}_{\text{max}}}$  is equal to the *Inter RF Bandwidth gap* minus half of the bandwidth of the measuring filter.
- $\Delta f_{\text{max}}$  is equal to  $f_{\text{offset}_{\text{max}}}$  minus half of the bandwidth of the measuring filter.

For a *multi-band RIB*, the operating band unwanted emission limits apply also in a supported operating band without any carrier transmitted, in the case where there are carrier(s) transmitted in another supported operating band. In this case, no cumulative limit is applied in the *inter-band gap* between a supported downlink operating band with carrier(s) transmitted and a supported downlink operating band without any carrier transmitted and

- In case the *inter-band gap* between a supported downlink operating band with carrier(s) transmitted and a supported downlink operating band without any carrier transmitted is less than  $2 \cdot \Delta f_{\text{OBUE}}$ ,  $f_{\text{offset}_{\text{max}}}$  shall be the offset to the frequency  $\Delta f_{\text{OBUE}}$  MHz outside the outermost edges of the two supported downlink operating bands and the operating band unwanted emission limit of the band where there are carriers transmitted, as defined in the tables of the present clause, shall apply across both downlink bands.
- In other cases, the operating band unwanted emission limit of the band where there are carriers transmitted, as defined in the tables of the present clause for the largest frequency offset ( $\Delta f_{\text{max}}$ ), shall apply from  $\Delta f_{\text{OBUE}}$  MHz below the lowest frequency, up to  $\Delta f_{\text{OBUE}}$  MHz above the highest frequency of the supported downlink operating band without any carrier transmitted.

For a multicarrier *single-band RIB* or a *single-band RIB* configured for intra-band contiguous or non-contiguous carrier aggregation the definitions above apply to the lower edge of the carrier transmitted at the lowest carrier frequency and the upper edge of the carrier transmitted at the highest carrier frequency within a specified frequency band.

In addition inside any sub-block gap for a *single-band RIB* operating in non-contiguous spectrum, emissions shall not exceed the cumulative sum of the test requirements specified for the adjacent sub blocks on each side of the sub block gap. The test requirement for each sub block is specified in the tables 6.7.4.5.1.1-1 to 6.7.4.5.1.5-3 below, where in this case:

- $\Delta f$  is the separation between the sub block edge frequency and the nominal -3 dB point of the measuring filter closest to the sub block edge.
- $f_{\text{offset}}$  is the separation between the sub block edge frequency and the centre of the measuring filter.
- $f_{\text{offset}_{\text{max}}}$  is equal to the sub block gap bandwidth minus half of the bandwidth of the measuring filter.
- $\Delta f_{\text{max}}$  is equal to  $f_{\text{offset}_{\text{max}}}$  minus half of the bandwidth of the measuring filter.

#### 6.7.4.5.1.1 Wide Area BS (Category A)

For a *RIB* operating in Bands n5, n8, n12, n13, n14, n26, n28, n29, n71, n85, n106, emissions shall not exceed the maximum levels specified in table 6.7.4.5.1.1-1.

**Table 6.7.4.5.1.1-1: Wide Area BS operating band unwanted emission limits (NR bands  $\leq 1$  GHz) for Category A**

Frequency offset of measurement filter -3dB point, $\Delta f$	Frequency offset of measurement filter centre frequency, $f_{\text{offset}}$	Test requirement (Note 1, 2, 4)	Measurement bandwidth
$0 \text{ MHz} \leq \Delta f < 5 \text{ MHz}$	$0.05 \text{ MHz} \leq f_{\text{offset}} < 5.05 \text{ MHz}$	$3.8 \text{ dBm} - 7/5(f_{\text{offset}}/\text{MHz} - 0.05) \text{ dB}$	100 kHz
$5 \text{ MHz} \leq \Delta f < \min(10 \text{ MHz}, \Delta f_{\text{max}})$	$5.05 \text{ MHz} \leq f_{\text{offset}} < \min(10.05 \text{ MHz}, f_{\text{offset}_{\text{max}}})$	-3.2 dBm	100 kHz
$10 \text{ MHz} \leq \Delta f \leq \Delta f_{\text{max}}$	$10.05 \text{ MHz} \leq f_{\text{offset}} < f_{\text{offset}_{\text{max}}}$	-4 dBm (Note 3)	100 kHz
<p>NOTE 1: For a BS supporting non-contiguous spectrum operation within any <i>operating band</i>, the emission limits within sub-block gaps is calculated as a cumulative sum of contributions from adjacent sub blocks on each side of the sub block gap. Exception is <math>\Delta f \geq 10\text{MHz}</math> from both adjacent sub blocks on each side of the sub-block gap, where the emission limits within sub-block gaps shall be -4 dBm/100 kHz.</p> <p>NOTE 2: For a <i>multi-band RIB</i> with Inter RF Bandwidth gap <math>&lt; 2 \cdot \Delta f_{\text{OBUe}}</math> the emission limits within the Inter RF Bandwidth gaps is calculated as a cumulative sum of contributions from adjacent sub-blocks or RF Bandwidth on each side of the Inter RF Bandwidth gap.</p> <p>NOTE 3: The requirement is not applicable when <math>\Delta f_{\text{max}} &lt; 10 \text{ MHz}</math>.</p> <p>NOTE 4: The test requirement is derived from the basic limit a scaling factor of 9 dB and any applicable TT.</p> <p>NOTE 5: Void</p>			

For a RIB operating in Bands n1, n2, n3, n7, n25, n30, n34, n38, n39, n40, n41, n50, n54, n65, n66, n70, n74, n75, n77, n78, n79, n109 emissions shall not exceed the maximum levels specified in tables 6.7.4.5.1.1-2 to 6.7.4.5.1.1-4:

**Table 6.7.4.5.1.1-2: Wide Area BS *operating band* unwanted emission limits (1 GHz  $<$  NR bands  $\leq 3$  GHz) for Category A**

Frequency offset of measurement filter -3dB point, $\Delta f$	Frequency offset of measurement filter centre frequency, $f_{\text{offset}}$	Test requirement (Note 1, 2, 4)	Measurement bandwidth
$0 \text{ MHz} \leq \Delta f < 5 \text{ MHz}$	$0.05 \text{ MHz} \leq f_{\text{offset}} < 5.05 \text{ MHz}$	$3.8 \text{ dBm} - 7/5(f_{\text{offset}}/\text{MHz} - 0.05) \text{ dB}$	100 kHz
$5 \text{ MHz} \leq \Delta f < \min(10 \text{ MHz}, \Delta f_{\text{max}})$	$5.05 \text{ MHz} \leq f_{\text{offset}} < \min(10.05 \text{ MHz}, f_{\text{offset}_{\text{max}}})$	-3.2 dBm	100 kHz
$10 \text{ MHz} \leq \Delta f \leq \Delta f_{\text{max}}$	$10.5 \text{ MHz} \leq f_{\text{offset}} < f_{\text{offset}_{\text{max}}}$	-4 dBm (Note 3)	1MHz
<p>NOTE 1: For a BS supporting non-contiguous spectrum operation within any <i>operating band</i>, the emission limits within sub-block gaps is calculated as a cumulative sum of contributions from adjacent sub blocks on each side of the sub block gap, where the contribution from the far-end sub-block shall be scaled according to the measurement bandwidth of the near-end sub-block. Exception is <math>\Delta f \geq 10\text{MHz}</math> from both adjacent sub blocks on each side of the sub-block gap, where the emission limits within sub-block gaps shall be -4 dBm/1 MHz.</p> <p>NOTE 2: For a <i>multi-band RIB</i> with Inter RF Bandwidth gap <math>&lt; 2 \cdot \Delta f_{\text{OBUe}}</math> the emission limits within the Inter RF Bandwidth gaps is calculated as a cumulative sum of contributions from adjacent sub-blocks or RF Bandwidth on each side of the Inter RF Bandwidth gap, where the contribution from the far-end sub-block or RF Bandwidth shall be scaled according to the measurement bandwidth of the near-end sub-block or RF Bandwidth.</p> <p>NOTE 3: The requirement is not applicable when <math>\Delta f_{\text{max}} &lt; 10 \text{ MHz}</math>.</p> <p>NOTE 4: The test requirement is derived from the basic limit a scaling factor of 9 dB and any applicable TT.</p> <p>NOTE 5: Void</p>			

**Table 6.7.4.5.1.1-3: Wide Area BS *operating band* unwanted emission limits  
(3 GHz < NR bands ≤ 4.2 GHz) for Category A**

Frequency offset of measurement filter -3dB point, $\Delta f$	Frequency offset of measurement filter centre frequency, $f_{\text{offset}}$	Test requirement (Note 1, 2, 4)	Measurement bandwidth
$0 \text{ MHz} \leq \Delta f < 5 \text{ MHz}$	$0.05 \text{ MHz} \leq f_{\text{offset}} < 5.05 \text{ MHz}$	$4 \text{ dBm} - 7/5(f_{\text{offset}}/\text{MHz} - 0.05)\text{dB}$	100 kHz
$5 \text{ MHz} \leq \Delta f < \min(10 \text{ MHz}, \Delta f_{\text{max}})$	$5.05 \text{ MHz} \leq f_{\text{offset}} < \min(10.05 \text{ MHz}, f_{\text{offset}_{\text{max}}})$	-3 dBm	100 kHz
$10 \text{ MHz} \leq \Delta f \leq \Delta f_{\text{max}}$	$10.5 \text{ MHz} \leq f_{\text{offset}} < f_{\text{offset}_{\text{max}}}$	-4 dBm (Note 3)	1MHz
<p>NOTE 1: For a BS supporting non-contiguous spectrum operation within any <i>operating band</i>, the emission limits within sub-block gaps is calculated as a cumulative sum of contributions from adjacent sub blocks on each side of the sub block gap, where the contribution from the far-end sub-block shall be scaled according to the measurement bandwidth of the near-end sub-block. Exception is <math>\Delta f \geq 10\text{MHz}</math> from both adjacent sub blocks on each side of the sub-block gap, where the emission limits within sub-block gaps shall be -4 dBm/1 MHz.</p> <p>NOTE 2: For a <i>multi-band RIB</i> with Inter RF Bandwidth gap &lt; <math>2 \cdot \Delta f_{\text{OBUe}}</math> the emission limits within the Inter RF Bandwidth gaps is calculated as a cumulative sum of contributions from adjacent sub-blocks or RF Bandwidth on each side of the Inter RF Bandwidth gap, where the contribution from the far-end sub-block or RF Bandwidth shall be scaled according to the measurement bandwidth of the near-end sub-block or RF Bandwidth.</p> <p>NOTE 3: The requirement is not applicable when <math>\Delta f_{\text{max}} &lt; 10 \text{ MHz}</math>.</p> <p>NOTE 4: The test requirement is derived from the basic limit a scaling factor of 9 dB and any applicable TT.</p> <p>NOTE 5: Void</p>			

**Table 6.7.4.5.1.1-4: Wide Area BS *operating band* unwanted emission limits  
(4.2 GHz < NR bands ≤ 6 GHz) for Category A**

Frequency offset of measurement filter -3dB point, $\Delta f$	Frequency offset of measurement filter centre frequency, $f_{\text{offset}}$	Test requirement (Note 1, 2, 4)	Measurement bandwidth
$0 \text{ MHz} \leq \Delta f < 5 \text{ MHz}$	$0.05 \text{ MHz} \leq f_{\text{offset}} < 5.05 \text{ MHz}$	$4 \text{ dBm} - 7/5(f_{\text{offset}}/\text{MHz} - 0.05)\text{dB}$	100 kHz
$5 \text{ MHz} \leq \Delta f < \min(10 \text{ MHz}, \Delta f_{\text{max}})$	$5.05 \text{ MHz} \leq f_{\text{offset}} < \min(10.05 \text{ MHz}, f_{\text{offset}_{\text{max}}})$	-3 dBm	100 kHz
$10 \text{ MHz} \leq \Delta f \leq \Delta f_{\text{max}}$	$10.5 \text{ MHz} \leq f_{\text{offset}} < f_{\text{offset}_{\text{max}}}$	-4 dBm (Note 3)	1MHz
<p>NOTE 1: For a BS supporting non-contiguous spectrum operation within any <i>operating band</i>, the emission limits within sub-block gaps is calculated as a cumulative sum of contributions from adjacent sub blocks on each side of the sub block gap, where the contribution from the far-end sub-block shall be scaled according to the measurement bandwidth of the near-end sub-block. Exception is <math>\Delta f \geq 10\text{MHz}</math> from both adjacent sub blocks on each side of the sub-block gap, where the emission limits within sub-block gaps shall be -4 dBm/1 MHz.</p> <p>NOTE 2: For a <i>multi-band RIB</i> with Inter RF Bandwidth gap &lt; <math>2 \cdot \Delta f_{\text{OBUe}}</math> the emission limits within the Inter RF Bandwidth gaps is calculated as a cumulative sum of contributions from adjacent sub-blocks or RF Bandwidth on each side of the Inter RF Bandwidth gap, where the contribution from the far-end sub-block or RF Bandwidth shall be scaled according to the measurement bandwidth of the near-end sub-block or RF Bandwidth.</p> <p>NOTE 3: The requirement is not applicable when <math>\Delta f_{\text{max}} &lt; 10 \text{ MHz}</math>.</p> <p>NOTE 4: The test requirement is derived from the basic limit a scaling factor of 9 dB and any applicable TT.</p> <p>NOTE 5: Void</p>			

#### 6.7.4.5.1.2 Wide Area BS Category B (Option 1)

For Category B operating band unwanted emissions, there are two options for the limits that may be applied regionally. option 1 is as follows.

For a *RIB* operating in Bands n5, n8, n12, n20, n26, n28, n29, n67, n71, n85, emissions shall not exceed the maximum levels specified in table 6.7.4.5.1.2-1:

**Table 6.7.4.5.1.2-1: Wide Area BS operating band unwanted emission limits  
(NR bands  $\leq 1$  GHz) for Category B**

Frequency offset of measurement filter -3dB point, $\Delta f$	Frequency offset of measurement filter centre frequency, $f_{\text{offset}}$	Test requirement (Note 1, 2, 4)	Measurement bandwidth
$0 \text{ MHz} \leq \Delta f < 5 \text{ MHz}$	$0.05 \text{ MHz} \leq f_{\text{offset}} < 5.05 \text{ MHz}$	$3.8 \text{ dBm} - 7/5(f_{\text{offset}}/\text{MHz} - 0.05)\text{dB}$	100 kHz
$5 \text{ MHz} \leq \Delta f < \min(10 \text{ MHz}, \Delta f_{\text{max}})$	$5.05 \text{ MHz} \leq f_{\text{offset}} < \min(10.05 \text{ MHz}, f_{\text{offset}_{\text{max}}})$	-3.2 dBm	100 kHz
$10 \text{ MHz} \leq \Delta f \leq \Delta f_{\text{max}}$	$10.05 \text{ MHz} \leq f_{\text{offset}} < f_{\text{offset}_{\text{max}}}$	-7 dBm (Note 3)	100 kHz
<p>NOTE 1: For a BS supporting non-contiguous spectrum operation within any <i>operating band</i>, the emission limits within sub-block gaps is calculated as a cumulative sum of contributions from adjacent sub blocks on each side of the sub block gap. Exception is <math>\Delta f \geq 10\text{MHz}</math> from both adjacent sub blocks on each side of the sub-block gap, where the emission limits within sub-block gaps shall be -7 dBm/ 100 kHz.</p> <p>NOTE 2: For a <i>multi-band RIB</i> with Inter RF Bandwidth gap <math>&lt; 2 \cdot \Delta f_{\text{OBUe}}</math> the emission limits within the Inter RF Bandwidth gaps is calculated as a cumulative sum of contributions from adjacent sub-blocks or RF Bandwidth on each side of the Inter RF Bandwidth gap, where the contribution from the far-end sub-block or RF Bandwidth shall be scaled according to the measurement bandwidth of the near-end sub-block or RF Bandwidth.</p> <p>NOTE 3: The requirement is not applicable when <math>\Delta f_{\text{max}} &lt; 10 \text{ MHz}</math>.</p> <p>NOTE 4: The test requirement is derived from the basic limit a scaling factor of 9 dB and any applicable TT.</p> <p>NOTE 5: Void</p>			

For a *RIB* operating in Bands n1, n2, n3, n7, n25, n34, n38, n39, n40, n41, n50, n65, n66, n70, n75, n77, n78, n79, n104, n109 emissions shall not exceed the maximum levels specified in tables 6.7.4.5.1.2-2 to 6.7.4.5.1.2-5:

**Table 6.7.4.5.1.2-2: Wide Area BS operating band unwanted emission limits  
( $1 \text{ GHz} < \text{NR bands} \leq 3 \text{ GHz}$ ) for Category B**

Frequency offset of measurement filter -3dB point, $\Delta f$	Frequency offset of measurement filter centre frequency, $f_{\text{offset}}$	Test requirement (Note 1, 2, 4)	Measurement bandwidth
$0 \text{ MHz} \leq \Delta f < 5 \text{ MHz}$	$0.05 \text{ MHz} \leq f_{\text{offset}} < 5.05 \text{ MHz}$	$3.8 \text{ dBm} - 7/5(f_{\text{offset}}/\text{MHz} - 0.05)\text{dB}$	100 kHz
$5 \text{ MHz} \leq \Delta f < \min(10 \text{ MHz}, \Delta f_{\text{max}})$	$5.05 \text{ MHz} \leq f_{\text{offset}} < \min(10.05 \text{ MHz}, f_{\text{offset}_{\text{max}}})$	-3.2 dBm	100 kHz
$10 \text{ MHz} \leq \Delta f \leq \Delta f_{\text{max}}$	$10.5 \text{ MHz} \leq f_{\text{offset}} < f_{\text{offset}_{\text{max}}}$	-6 dBm (Note 3)	1MHz
<p>NOTE 1: For a BS supporting non-contiguous spectrum operation within any <i>operating band</i>, the emission limits within sub-block gaps is calculated as a cumulative sum of contributions from adjacent sub blocks on each side of the sub block gap, where the contribution from the far-end sub-block shall be scaled according to the measurement bandwidth of the near-end sub-block. Exception is <math>\Delta f \geq 10\text{MHz}</math> from both adjacent sub blocks on each side of the sub-block gap, where the emission limits within sub-block gaps shall be -6 dBm/1 MHz.</p> <p>NOTE 2: For a <i>multi-band RIB</i> with Inter RF Bandwidth gap <math>&lt; 2 \cdot \Delta f_{\text{OBUe}}</math> the emission limits within the Inter RF Bandwidth gaps is calculated as a cumulative sum of contributions from adjacent sub-blocks or RF Bandwidth on each side of the Inter RF Bandwidth gap, where the contribution from the far-end sub-block or RF Bandwidth shall be scaled according to the measurement bandwidth of the near-end sub-block or RF Bandwidth.</p> <p>NOTE 3: The requirement is not applicable when <math>\Delta f_{\text{max}} &lt; 10 \text{ MHz}</math>.</p> <p>NOTE 4: The test requirement is derived from the basic limit a scaling factor of 9 dB and any applicable TT.</p> <p>NOTE 5: Void</p>			



**Table 6.7.4.5.1.2-3: Wide Area BS operating band unwanted emission limits  
(3 GHz < NR bands ≤ 4.2 GHz) for Category B**

Frequency offset of measurement filter -3dB point, $\Delta f$	Frequency offset of measurement filter centre frequency, $f_{\text{offset}}$	Test requirement (Note 1, 2, 4)	Measurement bandwidth
$0 \text{ MHz} \leq \Delta f < 5 \text{ MHz}$	$0.05 \text{ MHz} \leq f_{\text{offset}} < 5.05 \text{ MHz}$	$4 \text{ dBm} - 7/5(f_{\text{offset}}/\text{MHz} - 0.05)\text{dB}$	100 kHz
$5 \text{ MHz} \leq \Delta f < \min(10 \text{ MHz}, \Delta f_{\text{max}})$	$5.05 \text{ MHz} \leq f_{\text{offset}} < \min(10.05 \text{ MHz}, f_{\text{offset}_{\text{max}}})$	-3 dBm	100 kHz
$10 \text{ MHz} \leq \Delta f \leq \Delta f_{\text{max}}$	$10.5 \text{ MHz} \leq f_{\text{offset}} < f_{\text{offset}_{\text{max}}}$	-6 dBm (Note 3)	1MHz
<p>NOTE 1: For a BS supporting non-contiguous spectrum operation within any <i>operating band</i>, the emission limits within sub-block gaps is calculated as a cumulative sum of contributions from adjacent sub blocks on each side of the sub block gap, where the contribution from the far-end sub-block shall be scaled according to the measurement bandwidth of the near-end sub-block. Exception is <math>\Delta f \geq 10\text{MHz}</math> from both adjacent sub blocks on each side of the sub-block gap, where the emission limits within sub-block gaps shall be -6 dBm/1 MHz.</p> <p>NOTE 2: For a <i>multi-band RIB</i> with Inter RF Bandwidth gap &lt; <math>2 * \Delta f_{\text{OBUe}}</math> the emission limits within the Inter RF Bandwidth gaps is calculated as a cumulative sum of contributions from adjacent sub-blocks or RF Bandwidth on each side of the Inter RF Bandwidth gap, where the contribution from the far-end sub-block or RF Bandwidth shall be scaled according to the measurement bandwidth of the near-end sub-block or RF Bandwidth.</p> <p>NOTE 3: The requirement is not applicable when <math>\Delta f_{\text{max}} &lt; 10 \text{ MHz}</math>.</p> <p>NOTE 4: The test requirement is derived from the basic limit a scaling factor of 9 dB and any applicable TT.</p> <p>NOTE 5: Void</p>			

**Table 6.7.4.5.1.2-4: Wide Area BS operating band unwanted emission limits  
(4.2 GHz < NR bands ≤ 6 GHz) for Category B**

Frequency offset of measurement filter -3dB point, $\Delta f$	Frequency offset of measurement filter centre frequency, $f_{\text{offset}}$	Test requirement (Note 1, 2, 4)	Measurement bandwidth
$0 \text{ MHz} \leq \Delta f < 5 \text{ MHz}$	$0.05 \text{ MHz} \leq f_{\text{offset}} < 5.05 \text{ MHz}$	$4 \text{ dBm} - 7/5(f_{\text{offset}}/\text{MHz} - 0.05)\text{dB}$	100 kHz
$5 \text{ MHz} \leq \Delta f < \min(10 \text{ MHz}, \Delta f_{\text{max}})$	$5.05 \text{ MHz} \leq f_{\text{offset}} < \min(10.05 \text{ MHz}, f_{\text{offset}_{\text{max}}})$	-3 dBm	100 kHz
$10 \text{ MHz} \leq \Delta f \leq \Delta f_{\text{max}}$	$10.5 \text{ MHz} \leq f_{\text{offset}} < f_{\text{offset}_{\text{max}}}$	-6 dBm (Note 3)	1MHz
<p>NOTE 1: For a BS supporting non-contiguous spectrum operation within any <i>operating band</i>, the emission limits within sub-block gaps is calculated as a cumulative sum of contributions from adjacent sub blocks on each side of the sub block gap, where the contribution from the far-end sub-block shall be scaled according to the measurement bandwidth of the near-end sub-block. Exception is <math>\Delta f \geq 10\text{MHz}</math> from both adjacent sub blocks on each side of the sub-block gap, where the emission limits within sub-block gaps shall be -6 dBm/1 MHz.</p> <p>NOTE 2: For a <i>multi-band RIB</i> with Inter RF Bandwidth gap &lt; <math>2 * \Delta f_{\text{OBUe}}</math> the emission limits within the Inter RF Bandwidth gaps is calculated as a cumulative sum of contributions from adjacent sub-blocks or RF Bandwidth on each side of the Inter RF Bandwidth gap, where the contribution from the far-end sub-block or RF Bandwidth shall be scaled according to the measurement bandwidth of the near-end sub-block or RF Bandwidth.</p> <p>NOTE 3: The requirement is not applicable when <math>\Delta f_{\text{max}} &lt; 10 \text{ MHz}</math>.</p> <p>NOTE 4: The test requirement is derived from the basic limit a scaling factor of 9 dB and any applicable TT.</p> <p>NOTE 5: Void</p>			

**Table 6.7.4.5.1.2-5: Wide Area BS operating band unwanted emission limits  
(6 GHz < NR bands ≤ 7.125 GHz) for Category B**

Frequency offset of measurement filter -3dB point, $\Delta f$	Frequency offset of measurement filter centre frequency, $f_{\text{offset}}$	Basic limit (Note 1, 2, 5)	Measurement bandwidth
$0 \text{ MHz} \leq \Delta f < 50 \text{ MHz}$	$0.05 \text{ MHz} \leq f_{\text{offset}} < 50.05 \text{ MHz}$	$4 \text{ dBm} - \frac{7}{50} \cdot \left( \frac{f_{\text{offset}}}{\text{MHz}} - 0.05 \right) \text{ dB}$	100 kHz
(Note 4)			
$50 \text{ MHz} \leq \Delta f \leq \min(100 \text{ MHz}, \Delta f_{\text{max}})$	$50.05 \text{ MHz} \leq f_{\text{offset}} < \min(100.05 \text{ MHz}, f_{\text{offset}_{\text{max}}})$	-3 dBm	100 kHz
$100 \text{ MHz} \leq \Delta f \leq \Delta f_{\text{max}}$	$100.5 \text{ MHz} \leq f_{\text{offset}} < f_{\text{offset}_{\text{max}}}$	-6 dBm (Note 3)	1 MHz
<p>NOTE 1: For a BS supporting non-contiguous spectrum operation within any operating band, the minimum requirement within sub-block gaps is calculated as a cumulative sum of contributions from adjacent sub blocks on each side of the sub block gap, where the contribution from the far-end sub-block shall be scaled according to the measurement bandwidth of the near-end sub-block. Exception is <math>\Delta f \geq 100\text{MHz}</math> from both adjacent sub blocks on each side of the sub-block gap, where the minimum requirement within sub-block gaps shall be -6 dBm/1MHz.</p> <p>NOTE 2: For a <i>multi-band connector</i> with Inter RF Bandwidth gap &lt; <math>2 \cdot \Delta f_{\text{OBUe}}</math> the minimum requirement within the Inter RF Bandwidth gaps is calculated as a cumulative sum of contributions from adjacent sub-blocks or RF Bandwidth on each side of the Inter RF Bandwidth gap, where the contribution from the far-end sub-block or RF Bandwidth shall be scaled according to the measurement bandwidth of the near-end sub-block or RF Bandwidth.</p> <p>NOTE 3: The requirement is not applicable when <math>\Delta f_{\text{max}} &lt; 100 \text{ MHz}</math>.</p> <p>NOTE 4: This frequency range ensures that the range of values of <math>f_{\text{offset}}</math> is continuous.</p> <p>NOTE 5: The test requirement is derived from the basic limit a scaling factor of 9 dB and any applicable TT.</p>			

#### 6.7.4.5.1.3 Wide Area BS Category B (Option 2)

The limits in this clause are intended for Europe and may be applied regionally for a *RIB* operating in bands n1, n3, n8.

For a *RIB* operating in bands n1, n3, n8, n65 emissions shall not exceed the maximum levels specified in table 6.7.4.5.1.3-1:

**Table 6.7.4.5.1.3-1: Regional Wide Area BS operating band unwanted emission limits for Category B**

Frequency offset of measurement filter -3dB point, $\Delta f$	Frequency offset of measurement filter centre frequency, $f_{\text{offset}}$	Basic limit (Note 1, 2, 5)	Measurement bandwidth
$0 \text{ MHz} \leq \Delta f < 0.2 \text{ MHz}$	$0.015 \text{ MHz} \leq f_{\text{offset}} < 0.215 \text{ MHz}$	-3.2 dBm	30 kHz
$0.2 \text{ MHz} \leq \Delta f < 1 \text{ MHz}$	$0.215 \text{ MHz} \leq f_{\text{offset}} < 1.015 \text{ MHz}$	$-3.2 \text{ dBm} - 15 \cdot \left( \frac{f_{\text{offset}}}{\text{MHz}} - 0.215 \right) \text{ dB}$	30 kHz
(Note 4)	$1.015 \text{ MHz} \leq f_{\text{offset}} < 1.5 \text{ MHz}$	-15.2 dBm	30 kHz
$1 \text{ MHz} \leq \Delta f \leq \min(10 \text{ MHz}, \Delta f_{\text{max}})$	$1.5 \text{ MHz} \leq f_{\text{offset}} < \min(10.5 \text{ MHz}, f_{\text{offset}_{\text{max}}})$	-2.2 dBm	1 MHz
$10 \text{ MHz} \leq \Delta f \leq \Delta f_{\text{max}}$	$10.5 \text{ MHz} \leq f_{\text{offset}} < f_{\text{offset}_{\text{max}}}$	-6 dBm (Note 3)	1 MHz
<p>NOTE 1: For a BS supporting non-contiguous spectrum operation within any operating band, the minimum requirement within sub-block gaps is calculated as a cumulative sum of contributions from adjacent sub blocks on each side of the sub block gap, where the contribution from the far-end sub-block shall be scaled according to the measurement bandwidth of the near-end sub-block. Exception is <math>\Delta f \geq 10\text{MHz}</math> from both adjacent sub blocks on each side of the sub-block gap, where the minimum requirement within sub-block gaps shall be -6 dBm/1MHz.</p> <p>NOTE 2: For a <i>multi-band connector</i> with Inter RF Bandwidth gap &lt; <math>2 \cdot \Delta f_{\text{OBUe}}</math> the minimum requirement within the Inter RF Bandwidth gaps is calculated as a cumulative sum of contributions from adjacent sub-blocks or RF Bandwidth on each side of the Inter RF Bandwidth gap, where the contribution from the far-end sub-block or RF Bandwidth shall be scaled according to the measurement bandwidth of the near-end sub-block or RF Bandwidth.</p> <p>NOTE 3: The requirement is not applicable when <math>\Delta f_{\text{max}} &lt; 10 \text{ MHz}</math>.</p> <p>NOTE 4: This frequency range ensures that the range of values of <math>f_{\text{offset}}</math> is continuous.</p> <p>NOTE 5: The test requirement is derived from the basic limit a scaling factor of 9 dB and any applicable TT.</p> <p>NOTE 6: Void</p>			

## 6.7.4.5.1.4 Medium Range BS (Category A and Category B)

For Medium Range BS class in NR bands  $\leq 3$  GHz, emissions shall not exceed the maximum levels specified in tables 6.7.4.5.1.4-1 and 6.7.4.5.1.4-4.

For Medium Range BS class in 3GHz < NR bands  $\leq 4.2$  GHz, emissions shall not exceed the maximum levels specified in tables 6.7.4.5.1.4-2 and 6.7.4.5.1.4-5.

For Medium Range BS class in 4.2GHz < NR bands  $\leq 6$  GHz, emissions shall not exceed the maximum levels specified in tables 6.7.4.5.1.4-3 and 6.7.4.5.1.4-6.

For Medium Range BS class in 6.0 GHz < NR bands  $\leq 7.125$  GHz, emissions shall not exceed the maximum levels specified in tables 6.7.4.5.1.4-3a and 6.7.4.5.1.4-7.

**Table 6.7.4.5.1.4-1: Medium Range BS operating band unwanted emission limits,  $40 < P_{\text{rated,c,TRP}} \leq 47$  dBm (NR bands  $\leq 3$  GHz)**

Frequency offset of measurement filter -3dB point, $\Delta f$	Frequency offset of measurement filter centre frequency, $f_{\text{offset}}$	Test requirement (Note 1, 2, 4)	Measurement bandwidth
$0 \text{ MHz} \leq \Delta f < 5 \text{ MHz}$	$0.05 \text{ MHz} \leq f_{\text{offset}} < 5.05 \text{ MHz}$	$P_{\text{rated,c,TRP}} - 51.2 \text{ dB} - \frac{7}{5} \left( \frac{f_{\text{offset}}}{\text{MHz}} - 0.05 \right) \text{ dB}$	100 kHz
$5 \text{ MHz} \leq \Delta f < \min(10 \text{ MHz}, \Delta f_{\text{max}})$	$5.05 \text{ MHz} \leq f_{\text{offset}} < \min(10.05 \text{ MHz}, f_{\text{offset}_{\text{max}}})$	$P_{\text{rated,c,TRP}} - 58.2 \text{ dB}$	100 kHz
$10 \text{ MHz} \leq \Delta f \leq \Delta f_{\text{max}}$	$10.05 \text{ MHz} \leq f_{\text{offset}} < f_{\text{offset}_{\text{max}}}$	$\text{Min}(P_{\text{rated,c,TRP}} - 60 \text{ dB}, -16 \text{ dBm})$ (Note 3)	100 kHz
<p>NOTE 1: For a BS supporting non-contiguous spectrum operation within any <i>operating band</i> the emission limits within sub-block gaps is calculated as a cumulative sum of contributions from adjacent sub blocks on each side of the sub block gap. Exception is <math>\Delta f \geq 10</math> MHz from both adjacent sub blocks on each side of the sub-block gap, where the emission limits within sub-block gaps shall be <math>\text{Min}(P_{\text{rated,c,TRP}} - 60 \text{ dB}, -16 \text{ dBm})/100 \text{ KHz}</math>.</p> <p>NOTE 2: For a <i>multi-band RIB</i> with Inter RF Bandwidth gap <math>&lt; 2 * \Delta f_{\text{OBUE}}</math> the emission limits within the Inter RF Bandwidth gaps is calculated as a cumulative sum of contributions from adjacent sub-blocks or RF Bandwidth on each side of the Inter RF Bandwidth gap.</p> <p>NOTE 3: The requirement is not applicable when <math>\Delta f_{\text{max}} &lt; 10 \text{ MHz}</math>.</p> <p>NOTE 4: The test requirement is derived from the basic limit a scaling factor of 9 dB and any applicable TT.</p> <p>NOTE 5: Void</p>			

**Table 6.7.4.5.1.4-2: Medium Range BS operating band unwanted emission limits,  $40 < P_{\text{rated,c,TRP}} \leq 47$  dBm (3 GHz < NR bands  $\leq 4.2$  GHz)**

Frequency offset of measurement filter -3dB point, $\Delta f$	Frequency offset of measurement filter centre frequency, $f_{\text{offset}}$	Test requirement (Note 1, 2, 4)	Measurement bandwidth
$0 \text{ MHz} \leq \Delta f < 5 \text{ MHz}$	$0.05 \text{ MHz} \leq f_{\text{offset}} < 5.05 \text{ MHz}$	$P_{\text{rated,c,TRP}} - 51 \text{ dB} - \frac{7}{5} \left( \frac{f_{\text{offset}}}{\text{MHz}} - 0.05 \right) \text{ dB}$	100 kHz
$5 \text{ MHz} \leq \Delta f < \min(10 \text{ MHz}, \Delta f_{\text{max}})$	$5.05 \text{ MHz} \leq f_{\text{offset}} < \min(10.05 \text{ MHz}, f_{\text{offset}_{\text{max}}})$	$P_{\text{rated,c,TRP}} - 58 \text{ dB}$	100 kHz
$10 \text{ MHz} \leq \Delta f \leq \Delta f_{\text{max}}$	$10.05 \text{ MHz} \leq f_{\text{offset}} < f_{\text{offset}_{\text{max}}}$	$\text{Min}(P_{\text{rated,c,TRP}} - 60 \text{ dB}, -16 \text{ dBm})$ (Note 3)	100 kHz
<p>NOTE 1: For a BS supporting non-contiguous spectrum operation within any <i>operating band</i> the emission limits within sub-block gaps is calculated as a cumulative sum of contributions from adjacent sub blocks on each side of the sub block gap. Exception is <math>\Delta f \geq 10</math> MHz from both adjacent sub blocks on each side of the sub-block gap, where the emission limits within sub-block gaps shall be <math>\text{Min}(P_{\text{rated,c,TRP}} - 60 \text{ dB}, -16 \text{ dBm})/100 \text{ KHz}</math>.</p> <p>NOTE 2: For a <i>multi-band RIB</i> with Inter RF Bandwidth gap <math>&lt; 2 * \Delta f_{\text{OBUE}}</math> the emission limits within the Inter RF Bandwidth gaps is calculated as a cumulative sum of contributions from adjacent sub-blocks or RF Bandwidth on each side of the Inter RF Bandwidth gap.</p> <p>NOTE 3: The requirement is not applicable when <math>\Delta f_{\text{max}} &lt; 10 \text{ MHz}</math>.</p> <p>NOTE 4: The test requirement is derived from the basic limit a scaling factor of 9 dB and any applicable TT.</p> <p>NOTE 5: Void</p>			

**Table 6.7.4.5.1.4-3: Medium Range BS operating band unwanted emission limits,  $40 < P_{\text{rated,c,TRP}} \leq 47$  dBm ( 4.2 GHz < NR bands  $\leq$  6 GHz)**

Frequency offset of measurement filter -3dB point, $\Delta f$	Frequency offset of measurement filter centre frequency, $f_{\text{offset}}$	Test requirement (Note 1, 2, 4)	Measurement bandwidth
$0 \text{ MHz} \leq \Delta f < 5 \text{ MHz}$	$0.05 \text{ MHz} \leq f_{\text{offset}} < 5.05 \text{ MHz}$	$P_{\text{rated,c,TRP}} - 51 \text{ dB} - \frac{7}{5} \left( \frac{f_{\text{offset}}}{\text{MHz}} - 0.05 \right) \text{ dB}$	100 kHz
$5 \text{ MHz} \leq \Delta f < \min(10 \text{ MHz}, \Delta f_{\text{max}})$	$5.05 \text{ MHz} \leq f_{\text{offset}} < \min(10.05 \text{ MHz}, f_{\text{offset,max}})$	$P_{\text{rated,c,TRP}} - 58 \text{ dB}$	100 kHz
$10 \text{ MHz} \leq \Delta f \leq \Delta f_{\text{max}}$	$10.05 \text{ MHz} \leq f_{\text{offset}} < f_{\text{offset,max}}$	$\text{Min}(P_{\text{rated,c,TRP}} - 60 \text{ dB}, -16 \text{ dBm})$ (Note 3)	100 kHz
<p>NOTE 1: For a BS supporting non-contiguous spectrum operation within any <i>operating band</i> the emission limits within sub-block gaps is calculated as a cumulative sum of contributions from adjacent sub blocks on each side of the sub block gap. Exception is <math>\Delta f \geq 10\text{MHz}</math> from both adjacent sub blocks on each side of the sub-block gap, where the emission limits within sub-block gaps shall be <math>\text{Min}(P_{\text{rated,c,TRP}} - 60 \text{ dB}, -16 \text{ dBm})/100 \text{ KHz}</math>.</p> <p>NOTE 2: For a <i>multi-band RIB</i> with Inter RF Bandwidth gap <math>&lt; 2^* \Delta f_{\text{OBUe}}</math> the emission limits within the Inter RF Bandwidth gaps is calculated as a cumulative sum of contributions from adjacent sub-blocks or RF Bandwidth on each side of the Inter RF Bandwidth gap.</p> <p>NOTE 3: The requirement is not applicable when <math>\Delta f_{\text{max}} &lt; 10 \text{ MHz}</math>.</p> <p>NOTE 4: The test requirement is derived from the basic limit a scaling factor of 9 dB and any applicable TT.</p> <p>NOTE 5: Void</p>			

**Table 6.7.4.5.1.4-3a: Medium Range BS operating band unwanted emission limits,  $40 < P_{\text{rated,c,TRP}} \leq 47$  dBm (for 6.0 GHz < NR bands  $\leq$  7.125 GHz)**

Frequency offset of measurement filter -3dB point, $\Delta f$	Frequency offset of measurement filter centre frequency, $f_{\text{offset}}$	Test requirement (Note 1, 2, 4)	Measurement bandwidth
$0 \text{ MHz} \leq \Delta f < 50 \text{ MHz}$	$0.05 \text{ MHz} \leq f_{\text{offset}} < 50.05 \text{ MHz}$	$P_{\text{rated,x}} - 51 \text{ dB} - \frac{7}{50} \left( \frac{f_{\text{offset}}}{\text{MHz}} - 0.05 \right)$	100 kHz
$50 \text{ MHz} \leq \Delta f < \min(100 \text{ MHz}, \Delta f_{\text{max}})$	$50.05 \text{ MHz} \leq f_{\text{offset}} < \min(100.05 \text{ MHz}, f_{\text{offset,max}})$	$P_{\text{rated,x}} - 58 \text{ dB}$	100 kHz
$100 \text{ MHz} \leq \Delta f \leq \Delta f_{\text{max}}$	$100.05 \text{ MHz} \leq f_{\text{offset}} < f_{\text{offset,max}}$	$\text{Min}(P_{\text{rated,x}} - 60 \text{ dB}, -16 \text{ dBm})$ (Note 3)	100 kHz
<p>NOTE 1: For a BS supporting <i>non-contiguous spectrum</i> operation within any <i>operating band</i> the emission limits within sub-block gaps is calculated as a cumulative sum of contributions from adjacent sub-blocks on each side of the sub-block gap. Exception is <math>\Delta f \geq 100\text{MHz}</math> from both adjacent sub-blocks on each side of the sub-block gap, where the emission limits within sub-block gaps shall be <math>\text{Min}(P_{\text{rated,x}} - 60 \text{ dB}, -16 \text{ dBm})/100 \text{ kHz}</math>.</p> <p>NOTE 2: For a <i>multi-band connector</i> with Inter RF Bandwidth gap <math>&lt; 2^* \Delta f_{\text{OBUe}}</math> the emission limits within the Inter RF Bandwidth gaps is calculated as a cumulative sum of contributions from adjacent sub-blocks or RF Bandwidth on each side of the Inter RF Bandwidth gap.</p> <p>NOTE 3: The requirement is not applicable when <math>\Delta f_{\text{max}} &lt; 100 \text{ MHz}</math>.</p> <p>NOTE 4: The test requirement is derived from the basic limit applying a scaling factor of 9 dB and any applicable TT.</p>			

Table 6.7.4.5.1.4-4: Medium Range BS operating band unwanted emission limits,  $P_{\text{rated,c,TRP}} \leq 40$  dBm(NR bands  $\leq 3$  GHz)

Frequency offset of measurement filter -3dB point, $\Delta f$	Frequency offset of measurement filter centre frequency, $f_{\text{offset}}$	Test requirement (Note 1, 2, 4)	Measurement bandwidth
$0 \text{ MHz} \leq \Delta f < 5 \text{ MHz}$	$0.05 \text{ MHz} \leq f_{\text{offset}} < 5.05 \text{ MHz}$	$-11.2 \text{ dB} - \frac{7}{5} \left( \frac{f_{\text{offset}}}{\text{MHz}} - 0.05 \right) \text{ dB}$	100 kHz
$5 \text{ MHz} \leq \Delta f < \min(10 \text{ MHz}, \Delta f_{\text{max}})$	$5.05 \text{ MHz} \leq f_{\text{offset}} < \min(10.05 \text{ MHz}, f_{\text{offset}_{\text{max}}})$	-18.2 dBm	100 kHz
$10 \text{ MHz} \leq \Delta f \leq \Delta f_{\text{max}}$	$10.05 \text{ MHz} \leq f_{\text{offset}} < f_{\text{offset}_{\text{max}}}$	-20 dBm (Note 3)	100 kHz
<p>NOTE 1: For a BS supporting non-contiguous spectrum operation within any <i>operating band</i> the emission limits within sub-block gaps is calculated as a cumulative sum of contributions from adjacent sub blocks on each side of the sub block gap. Exception is <math>\Delta f \geq 10</math> MHz from both adjacent sub blocks on each side of the sub-block gap, where the emission limits within sub-block gaps shall be -20 dBm/100 KHz.</p> <p>NOTE 2: For a <i>multi-band RIB</i> with Inter RF Bandwidth gap <math>&lt; 2 \cdot \Delta f_{\text{OBUE}}</math> the emission limits within the Inter RF Bandwidth gaps is calculated as a cumulative sum of contributions from adjacent sub-blocks or RF Bandwidth on each side of the Inter RF Bandwidth gap.</p> <p>NOTE 3: The requirement is not applicable when <math>\Delta f_{\text{max}} &lt; 10</math> MHz.</p> <p>NOTE 4: The test requirement is derived from the basic limit a scaling factor of 9 dB and any applicable TT.</p> <p>NOTE 5: Void</p>			

Table 6.7.4.5.1.4-5: Medium Range BS operating band unwanted emission limits,  $P_{\text{rated,c,TRP}} \leq 40$  dBm(3 GHz  $<$  NR bands  $\leq 4.2$  GHz)

Frequency offset of measurement filter -3dB point, $\Delta f$	Frequency offset of measurement filter centre frequency, $f_{\text{offset}}$	Test requirement (Note 1, 2, 4)	Measurement bandwidth
$0 \text{ MHz} \leq \Delta f < 5 \text{ MHz}$	$0.05 \text{ MHz} \leq f_{\text{offset}} < 5.05 \text{ MHz}$	$-1 \text{ dB} - \frac{7}{5} \left( \frac{f_{\text{offset}}}{\text{MHz}} - 0.05 \right) \text{ dB}$	100 kHz
$5 \text{ MHz} \leq \Delta f < \min(10 \text{ MHz}, \Delta f_{\text{max}})$	$5.05 \text{ MHz} \leq f_{\text{offset}} < \min(10.05 \text{ MHz}, f_{\text{offset}_{\text{max}}})$	-18 dBm	100 kHz
$10 \text{ MHz} \leq \Delta f \leq \Delta f_{\text{max}}$	$10.05 \text{ MHz} \leq f_{\text{offset}} < f_{\text{offset}_{\text{max}}}$	-20 dBm (Note 3)	100 kHz
<p>NOTE 1: For a BS supporting non-contiguous spectrum operation within any <i>operating band</i> the emission limits within sub-block gaps is calculated as a cumulative sum of contributions from adjacent sub blocks on each side of the sub block gap. Exception is <math>\Delta f \geq 10</math> MHz from both adjacent sub blocks on each side of the sub-block gap, where the emission limits within sub-block gaps shall be -20 dBm/100 KHz.</p> <p>NOTE 2: For a <i>multi-band RIB</i> with Inter RF Bandwidth gap <math>&lt; 2 \cdot \Delta f_{\text{OBUE}}</math> the emission limits within the Inter RF Bandwidth gaps is calculated as a cumulative sum of contributions from adjacent sub-blocks or RF Bandwidth on each side of the Inter RF Bandwidth gap.</p> <p>NOTE 3: The requirement is not applicable when <math>\Delta f_{\text{max}} &lt; 10</math> MHz.</p> <p>NOTE 4: The test requirement is derived from the basic limit a scaling factor of 9 dB and any applicable TT.</p> <p>NOTE 5: Void</p>			

**Table 6.7.4.5.1.4-6: Medium Range BS operating band unwanted emission limits,  $P_{\text{rated,c,TRP}} \leq 40$  dBm  
(4.2 GHz < NR bands  $\leq$  6 GHz)**

Frequency offset of measurement filter -3dB point, $\Delta f$	Frequency offset of measurement filter centre frequency, $f_{\text{offset}}$	Test requirement (Note 1, 2, 4)	Measurement bandwidth
$0 \text{ MHz} \leq \Delta f < 5 \text{ MHz}$	$0.05 \text{ MHz} \leq f_{\text{offset}} < 5.05 \text{ MHz}$	$-11\text{dB} - \frac{7}{5} \left( \frac{f_{\text{offset}}}{\text{MHz}} - 0.05 \right) \text{dB}$	100 kHz
$5 \text{ MHz} \leq \Delta f < \min(10 \text{ MHz}, \Delta f_{\text{max}})$	$5.05 \text{ MHz} \leq f_{\text{offset}} < \min(10.05 \text{ MHz}, f_{\text{offset}_{\text{max}}})$	-18 dBm	100 kHz
$10 \text{ MHz} \leq \Delta f \leq \Delta f_{\text{max}}$	$10.05 \text{ MHz} \leq f_{\text{offset}} < f_{\text{offset}_{\text{max}}}$	-20 dBm (Note 3)	100 kHz
<p>NOTE 1: For a BS supporting non-contiguous spectrum operation within any <i>operating band</i> the emission limits within sub-block gaps is calculated as a cumulative sum of contributions from adjacent sub blocks on each side of the sub block gap. Exception is <math>\Delta f \geq 10\text{MHz}</math> from both adjacent sub blocks on each side of the sub-block gap, where the emission limits within sub-block gaps shall be -20 dBm/100 KHz.</p> <p>NOTE 2: For a <i>multi-band RIB</i> with Inter RF Bandwidth gap &lt; <math>2 \cdot \Delta f_{\text{OBUE}}</math> the emission limits within the Inter RF Bandwidth gaps is calculated as a cumulative sum of contributions from adjacent sub-blocks or RF Bandwidth on each side of the Inter RF Bandwidth gap.</p> <p>NOTE 3: The requirement is not applicable when <math>\Delta f_{\text{max}} &lt; 10</math> MHz.</p> <p>NOTE 4: The test requirement is derived from the basic limit a scaling factor of 9 dB and any applicable TT.</p> <p>NOTE 5: Void</p>			

**Table 6.7.4.5.1.4-7: Medium Range BS operating band unwanted emission limits,  $P_{\text{rated,c,TRP}} \leq 40$  dBm  
(for 6.0 GHz < NR bands  $\leq$  7.125 GHz)**

Frequency offset of measurement filter -3dB point, $\Delta f$	Frequency offset of measurement filter centre frequency, $f_{\text{offset}}$	Test requirement (Note 1, 2, 4)	Measurement bandwidth
$0 \text{ MHz} \leq \Delta f < 50 \text{ MHz}$	$0.05 \text{ MHz} \leq f_{\text{offset}} < 50.05 \text{ MHz}$	$-11\text{dBm} - \frac{7}{50} \left( \frac{f_{\text{offset}}}{\text{MHz}} - 0.05 \right)$	100 kHz
$50 \text{ MHz} \leq \Delta f < \min(100 \text{ MHz}, \Delta f_{\text{max}})$	$50.05 \text{ MHz} \leq f_{\text{offset}} < \min(100.05 \text{ MHz}, f_{\text{offset}_{\text{max}}})$	-18 dBm	100 kHz
$100 \text{ MHz} \leq \Delta f \leq \Delta f_{\text{max}}$	$100.05 \text{ MHz} \leq f_{\text{offset}} < f_{\text{offset}_{\text{max}}}$	-20 dBm	100 kHz
<p>NOTE 1: For a BS supporting <i>non-contiguous spectrum</i> operation within any <i>operating band</i> the emission limits within sub-block gaps is calculated as a cumulative sum of contributions from adjacent sub-blocks on each side of the sub-block gap. Exception is <math>\Delta f \geq 100\text{MHz}</math> from both adjacent sub-blocks on each side of the sub-block gap, where the emission limits within sub-block gaps shall be -20 dBm/100 kHz.</p> <p>NOTE 2: For a <i>multi-band connector</i> with Inter RF Bandwidth gap &lt; <math>2 \cdot \Delta f_{\text{OBUE}}</math> the emission limits within the Inter RF Bandwidth gaps is calculated as a cumulative sum of contributions from adjacent sub-blocks or RF Bandwidth on each side of the Inter RF Bandwidth gap.</p> <p>NOTE 3: The requirement is not applicable when <math>\Delta f_{\text{max}} &lt; 100</math> MHz.</p> <p>NOTE 4: The test requirement is derived from the basic limit a scaling factor of 9 dB and any applicable TT.</p>			

#### 6.7.4.5.1.5 Local Area BS (Category A and Category B)

For Local Area BS class in NR bands  $\leq 3$  GHz, emissions shall not exceed the maximum levels specified in table 6.7.4.5.1.5-1.

For Local Area BS class in 3 GHz < NR bands  $\leq 4.2$  GHz, emissions shall not exceed the maximum levels specified in tables 6.7.4.5.1.5-2.

For Local Area BS class in 4.2 GHz < NR bands  $\leq 6$  GHz, emissions shall not exceed the maximum levels specified in tables 6.7.4.5.1.5-3.

For Local Area BS class in 6.0 GHz < NR bands  $\leq 7.125$  GHz, emissions shall not exceed the maximum levels specified in tables 6.7.4.5.1.5-4.

Table 6.7.4.5.1.5-1: Local Area BS operating band unwanted emission limits (NR bands ≤ 3 GHz)

Frequency offset of measurement filter -3dB point, $\Delta f$	Frequency offset of measurement filter centre frequency, $f_{\text{offset}}$	Test requirement (Note 1, 2, 4)	Measurement bandwidth
$0 \text{ MHz} \leq \Delta f < 5 \text{ MHz}$	$0.05 \text{ MHz} \leq f_{\text{offset}} < 5.05 \text{ MHz}$	$-19.2 \text{ dB} - \frac{7}{5} \left( \frac{f_{\text{offset}}}{\text{MHz}} - 0.05 \right) \text{ dB}$	100 kHz
$5 \text{ MHz} \leq \Delta f < \min(10 \text{ MHz}, \Delta f_{\text{max}})$	$5.05 \text{ MHz} \leq f_{\text{offset}} < \min(10.05 \text{ MHz}, f_{\text{offset}_{\text{max}}})$	-26.2 dBm	100 kHz
$10 \text{ MHz} \leq \Delta f \leq \Delta f_{\text{max}}$	$10.05 \text{ MHz} \leq f_{\text{offset}} < f_{\text{offset}_{\text{max}}}$	-28 dBm (Note 3)	100 kHz
NOTE 1: For a BS supporting non-contiguous spectrum operation within any <i>operating band</i> the emission limits within sub-block gaps is calculated as a cumulative sum of contributions from adjacent sub blocks on each side of the sub block gap. Exception is $\Delta f \geq 10 \text{ MHz}$ from both adjacent sub blocks on each side of the sub-block gap, where the emission limits within sub-block gaps shall be -28 dBm/100 KHz.			
NOTE 2: For a <i>multi-band RIB</i> with Inter RF Bandwidth gap $< 2 * \Delta f_{\text{OBUE}}$ the emission limits within the Inter RF Bandwidth gaps is calculated as a cumulative sum of contributions from adjacent sub-blocks or RF Bandwidth on each side of the Inter RF Bandwidth gap			
NOTE 3: The requirement is not applicable when $\Delta f_{\text{max}} < 10 \text{ MHz}$ .			
NOTE 4: The test requirement is derived from the basic limit a scaling factor of 9 dB and any applicable TT.			
NOTE 5: Void			

Table 6.7.4.5.1.5-2: Local Area BS operating band unwanted emission limits (3 GHz &lt; NR bands ≤ 4.2 GHz)

Frequency offset of measurement filter -3dB point, $\Delta f$	Frequency offset of measurement filter centre frequency, $f_{\text{offset}}$	Test requirement (Note 1, 2, 4)	Measurement bandwidth
$0 \text{ MHz} \leq \Delta f < 5 \text{ MHz}$	$0.05 \text{ MHz} \leq f_{\text{offset}} < 5.05 \text{ MHz}$	$-19 \text{ dB} - \frac{7}{5} \left( \frac{f_{\text{offset}}}{\text{MHz}} - 0.05 \right) \text{ dB}$	100 kHz
$5 \text{ MHz} \leq \Delta f < \min(10 \text{ MHz}, \Delta f_{\text{max}})$	$5.05 \text{ MHz} \leq f_{\text{offset}} < \min(10.05 \text{ MHz}, f_{\text{offset}_{\text{max}}})$	-26 dBm	100 kHz
$10 \text{ MHz} \leq \Delta f \leq \Delta f_{\text{max}}$	$10.05 \text{ MHz} \leq f_{\text{offset}} < f_{\text{offset}_{\text{max}}}$	-28 dBm (Note 3)	100 kHz
NOTE 1: For a BS supporting non-contiguous spectrum operation within any <i>operating band</i> the emission limits within sub-block gaps is calculated as a cumulative sum of contributions from adjacent sub blocks on each side of the sub block gap. Exception is $\Delta f \geq 10 \text{ MHz}$ from both adjacent sub blocks on each side of the sub-block gap, where the emission limits within sub-block gaps shall be -28 dBm/100 KHz.			
NOTE 2: For a <i>multi-band RIB</i> with Inter RF Bandwidth gap $< 2 * \Delta f_{\text{OBUE}}$ the emission limits within the Inter RF Bandwidth gaps is calculated as a cumulative sum of contributions from adjacent sub-blocks or RF Bandwidth on each side of the Inter RF Bandwidth gap			
NOTE 3: The requirement is not applicable when $\Delta f_{\text{max}} < 10 \text{ MHz}$ .			
NOTE 4: The test requirement is derived from the basic limit a scaling factor of 9 dB and any applicable TT.			
NOTE 5: Void			

**Table 6.7.4.5.1.5-3: Local Area BS operating band unwanted emission limits (4.2 GHz < NR bands ≤ 6 GHz)**

Frequency offset of measurement filter -3dB point, $\Delta f$	Frequency offset of measurement filter centre frequency, $f_{\text{offset}}$	Test requirement (Note 1, 2, 4)	Measurement bandwidth
$0 \text{ MHz} \leq \Delta f < 5 \text{ MHz}$	$0.05 \text{ MHz} \leq f_{\text{offset}} < 5.05 \text{ MHz}$	$-19\text{dB} - \frac{7}{5} \left( \frac{f_{\text{offset}}}{\text{MHz}} - 0.05 \right) \text{dB}$	100 kHz
$5 \text{ MHz} \leq \Delta f < \min(10 \text{ MHz}, \Delta f_{\text{max}})$	$5.05 \text{ MHz} \leq f_{\text{offset}} < \min(10.05 \text{ MHz}, f_{\text{offset}_{\text{max}}})$	-26 dBm	100 kHz
$10 \text{ MHz} \leq \Delta f \leq \Delta f_{\text{max}}$	$10.05 \text{ MHz} \leq f_{\text{offset}} < f_{\text{offset}_{\text{max}}}$	-28 dBm (Note 3)	100 kHz
<p>NOTE 1: For a BS supporting non-contiguous spectrum operation within any <i>operating band</i> the emission limits within sub-block gaps is calculated as a cumulative sum of contributions from adjacent sub blocks on each side of the sub block gap. Exception is <math>\Delta f \geq 10\text{MHz}</math> from both adjacent sub blocks on each side of the sub-block gap, where the emission limits within sub-block gaps shall be -28 dBm/100 KHz.</p> <p>NOTE 2: For a <i>multi-band RIB</i> with Inter RF Bandwidth gap &lt; <math>2 \cdot \Delta f_{\text{OBUE}}</math> the emission limits within the Inter RF Bandwidth gaps is calculated as a cumulative sum of contributions from adjacent sub-blocks or RF Bandwidth on each side of the Inter RF Bandwidth gap</p> <p>NOTE 3: The requirement is not applicable when <math>\Delta f_{\text{max}} &lt; 10 \text{ MHz}</math>.</p> <p>NOTE 4: The test requirement is derived from the basic limit a scaling factor of 9 dB and any applicable TT.</p> <p>NOTE 5: Void</p>			

**Table 6.7.4.5.1.5-4: Local Area BS operating band unwanted emission limits (for 6.0 GHz < NR bands ≤ 7.125 GHz)**

Frequency offset of measurement filter -3dB point, $\Delta f$	Frequency offset of measurement filter centre frequency, $f_{\text{offset}}$	Test requirement (Note 1, 2, 4)	Measurement bandwidth
$0 \text{ MHz} \leq \Delta f < 50 \text{ MHz}$	$0.05 \text{ MHz} \leq f_{\text{offset}} < 50.05 \text{ MHz}$	$-19\text{dBm} - \frac{7}{50} \left( \frac{f_{\text{offset}}}{\text{MHz}} - 0.05 \right)$	100 kHz
$50 \text{ MHz} \leq \Delta f < \min(100 \text{ MHz}, \Delta f_{\text{max}})$	$50.05 \text{ MHz} \leq f_{\text{offset}} < \min(100.05 \text{ MHz}, f_{\text{offset}_{\text{max}}})$	-26 dBm	100 kHz
$100 \text{ MHz} \leq \Delta f \leq \Delta f_{\text{max}}$	$100.05 \text{ MHz} \leq f_{\text{offset}} < f_{\text{offset}_{\text{max}}}$	-28 dBm	100 kHz
<p>NOTE 1: For a BS supporting <i>non-contiguous spectrum</i> operation within any <i>operating band</i> the emission limits within sub-block gaps is calculated as a cumulative sum of contributions from adjacent sub-blocks on each side of the sub-block gap. Exception is <math>\Delta f \geq 100\text{MHz}</math> from both adjacent sub-blocks on each side of the sub-block gap, where the emission limits within sub-block gaps shall be -28 dBm/100 kHz.</p> <p>NOTE 2: For a <i>multi-band connector</i> with Inter RF Bandwidth gap &lt; <math>2 \cdot \Delta f_{\text{OBUE}}</math> the emission limits within the Inter RF Bandwidth gaps is calculated as a cumulative sum of contributions from adjacent sub-blocks or RF Bandwidth on each side of the Inter RF Bandwidth gap</p> <p>NOTE 3: The requirement is not applicable when <math>\Delta f_{\text{max}} &lt; 100 \text{ MHz}</math>.</p> <p>NOTE 4: The test requirement is derived from the basic limit a scaling factor of 9 dB and any applicable TT.</p>			

#### 6.7.4.5.1.6 Additional requirements

##### 6.7.4.5.1.6.1 Limits in FCC Title 47

In addition to the requirements in tables 6.7.4.5.1.1-1 to 6.7.4.5.1.5-3, the BS may have to comply with the applicable emission limits established by FCC Title 47 [14], when deployed in regions where those limits are applied, and under the conditions declared by the manufacturer.

##### 6.7.4.5.1.6.2 Protection of DTT

In certain regions the following requirement may apply for protection of DTT. For *BS type 1-O* operating in Band n20, the level of emissions in the band 470-790 MHz, measured in an 8 MHz filter bandwidth on centre frequencies  $F_{\text{filter}}$  according to table 6.7.4.5.1.6.2-1, shall not exceed the maximum emission TRP level shown in the table. This requirement applies in the frequency range 470-790 MHz even though part of the range falls in the spurious domain.



Table 6.7.4.5.1.6.2-1: Declared emissions levels for protection of DTT

Case	Measurement filter centre frequency	Condition on BS maximum aggregate EIRP / 10 MHz, $P_{\text{EIRP}_10\text{MHz}}$ (NOTE)	Maximum level $P_{\text{EIRP},N,\text{MAX}}$	Measurement bandwidth
A: for DTT frequencies where broadcasting is protected	$N*8 + 306 \text{ MHz}$ , $21 \leq N \leq 60$	$P_{\text{EIRP}_10\text{MHz}} \geq 59 \text{ dBm}$	0 dBm	8 MHz
	$N*8 + 306 \text{ MHz}$ , $21 \leq N \leq 60$	$36 \leq P_{\text{EIRP}_10\text{MHz}} < 59 \text{ dBm}$	$P_{\text{EIRP}_10\text{MHz}} - 59 \text{ dBm}$	8 MHz
	$N*8 + 306 \text{ MHz}$ , $21 \leq N \leq 60$	$P_{\text{EIRP}_10\text{MHz}} < 36 \text{ dBm}$	-23 dBm	8 MHz
B: for DTT frequencies where broadcasting is subject to an intermediate level of protection	$N*8 + 306 \text{ MHz}$ , $21 \leq N \leq 60$	$P_{\text{EIRP}_10\text{MHz}} \geq 59 \text{ dBm}$	10 dBm	8 MHz
	$N*8 + 306 \text{ MHz}$ , $21 \leq N \leq 60$	$36 \leq P_{\text{EIRP}_10\text{MHz}} < 59 \text{ dBm}$	$P_{\text{EIRP}_10\text{MHz}} - 49 \text{ dBm}$	8 MHz
	$N*8 + 306 \text{ MHz}$ , $21 \leq N \leq 60$	$P_{\text{EIRP}_10\text{MHz}} < 36 \text{ dBm}$	-13 dBm	8 MHz
C: for DTT frequencies where broadcasting is not protected	$N*8 + 306 \text{ MHz}$ , $21 \leq N \leq 60$	N.A.	22 dBm	8 MHz
NOTE: $P_{\text{EIRP}_10\text{MHz}}$ (dBm) is defined by $P_{\text{EIRP}_10\text{MHz}} = P_{10\text{MHz}} + G_{\text{ant}} + 9\text{dB}$ , where $G_{\text{ant}}$ is 17 dBi.				

## 6.7.4.5.1.6.3 Protection of GPS

In regions where FCC regulation applies, requirements for protection of GPS according to FCC Order DA 10-48 applies for operation in Band n24. The following normative requirement covers *BS type I-O* operating in Band n24 to verify compliance with the requirement in FCC Order DA 10-48.

The level of emissions in the 1541 – 1650 MHz band, measured in measurement bandwidth according to Table 6.7.4.5.1.6.3-1 shall not exceed the maximum emission TRP limits indicated in the table. This requirement applies in the frequency range 1541-1650 MHz even though part of the range falls in the spurious domain.

Table 6.7.4.5.1.6.3-1: Emissions levels for protection of GPS

Operating Band	Frequency range (MHz)	Emission level (dBW) (Measurement bandwidth = 1 MHz)	Emission level (dBW) of discrete emissions of less than 700 Hz bandwidth (Measurement bandwidth = 1 kHz)	Emission level (dBW) of discrete emissions of less than 2 kHz bandwidth (Measurement bandwidth = 1 kHz)
n24	1541 - 1559	$P_{\text{EIRP}} - 17 \text{ dBi} + 9 \text{ dB}$		$P_{\text{EIRP}} - 17 \text{ dBi} + 9 \text{ dB}$
	1559 - 1610	$P_{\text{EIRP}} - 17 \text{ dBi} + 9 \text{ dB}$	$P_{\text{EIRP}} - 17 \text{ dBi} + 9 \text{ dB}$	
	1610 - 1650	$P_{\text{EIRP}} - 17 \text{ dBi} + 9 \text{ dB}$	$P_{\text{EIRP}} - 17 \text{ dBi} + 9 \text{ dB}$	

Note: The regional requirements in FCC Order DA 20-48 are defined in terms of EIRP (effective isotropic radiated power), which is dependent on both the BS emissions at the antenna connector and the deployment (including antenna gain and feeder loss).  $P_{\text{EIRP}}$  values in table 6.7.4.5.1.6.3-1 are the effective isotropic power (or radiated power spectral density) set in the FCC Order DA 20-48 for the specified frequency ranges and bandwidths.

## 6.7.4.5.1.6.4 Additional limits for BS operating in Bands n50, n51, n74, n75, n76

For BS operating in bands n50, n51, n74, n75 and n76 additional emission limits that might be applicable in the OBUE frequency domain are specified in clause 6.7.5.4.5.

## 6.7.4.5.2 BS type 2-O

### 6.7.4.5.2.1 General

The requirements of either clause 6.7.4.5.2.2 (Category A limits) or clause 6.7.4.5.2.3 (Category B limits) shall apply. The application of either Category A or Category B limits shall be the same as for General OTA transmitter spurious emissions requirements (*BS type 2-O*) in clause 6.7.5.2.5.2. In addition, the limits in clause 6.7.4.5.2.4 may also apply. The emission measurement result shall not exceed the maximum levels specified in the tables below, where:

- $\Delta f$  is the separation between the *contiguous transmission bandwidth* edge frequency and the nominal -3dB point of the measuring filter closest to the *contiguous transmission bandwidth* edge.
- $f_{\text{offset}}$  is the separation between the *contiguous transmission bandwidth* edge frequency and the centre of the measuring filter.
- $f_{\text{offset}_{\text{max}}}$  is the offset to the frequency  $\Delta f_{\text{OBUE}}$  outside the downlink *operating band*, where  $\Delta f_{\text{OBUE}}$  is defined in table 6.7.1-1.

In addition, inside any sub-block gap for a *RIB* operating in non-contiguous spectrum, emissions shall not exceed the cumulative sum of the test requirements specified for the adjacent sub blocks on each side of the sub block gap. The test requirement for each sub-block is specified in the clauses 6.7.4.5.2.2 and 6.7.4.5.2.3 below, where in this case:

- $\Delta f$  is the separation between the sub block edge frequency and the nominal -3 dB point of the measuring filter closest to the sub block edge.
- $f_{\text{offset}}$  is the separation between the sub block edge frequency and the centre of the measuring filter.
- $f_{\text{offset}_{\text{max}}}$  is equal to the sub block gap bandwidth minus half of the bandwidth of the measuring filter.
- $\Delta f_{\text{max}}$  is equal to  $f_{\text{offset}_{\text{max}}}$  minus half of the bandwidth of the measuring filter.

**Table 6.7.4.5.2-1: Void**

**Table 6.7.4.5.2-2: Void**

### 6.7.4.5.2.2 OTA operating band unwanted emission limits (Category A)

The power of unwanted emission shall not exceed the limits in table 6.7.4.5.2.2-1, 6.7.4.5.2.2-2 or 6.7.4.5.2.2-3.

**Table 6.7.4.5.2.2-1: OBUE limits applicable in the frequency range 24.25 – 33.4 GHz**

Frequency offset of measurement filter -3 dB point, $\Delta f$	Frequency offset of measurement filter centre frequency, $f_{\text{offset}}$	Test limit	Measurement bandwidth
$0 \text{ MHz} \leq \Delta f < 0.1 * \text{BW}_{\text{contiguous}}$	$0.5 \text{ MHz} \leq f_{\text{offset}} < 0.1 * \text{BW}_{\text{contiguous}} + 0.5 \text{ MHz}$	Min(-2.3 dBm, Max( $P_{\text{rated,t,TRP}}$ – 32.3 dB, -9.3 dBm))	1 MHz
$0.1 * \text{BW}_{\text{contiguous}} \leq \Delta f < \Delta f_{\text{max}}$	$0.1 * \text{BW}_{\text{contiguous}} + 0.5 \text{ MHz} \leq f_{\text{offset}} < f_{\text{offset}_{\text{max}}}$	Min(-13 dBm, Max( $P_{\text{rated,t,TRP}}$ – 43 dB, -20 dBm))	1 MHz
NOTE: For non-contiguous spectrum operation within any operating band the limit within sub-block gaps is calculated as a cumulative sum of contributions from adjacent sub blocks on each side of the sub block gap.			

**Table 6.7.4.5.2.2-2: OBUE limits applicable in the frequency range 37– 43.5 GHz**

Frequency offset of measurement filter -3 dB point, $\Delta f$	Frequency offset of measurement filter centre frequency, $f_{\text{offset}}$	Test limit	Measurement bandwidth
$0 \text{ MHz} \leq \Delta f < 0.1 * \text{BW}_{\text{contiguous}}$	$0.5 \text{ MHz} \leq f_{\text{offset}} < 0.1 * \text{BW}_{\text{contiguous}} + 0.5 \text{ MHz}$	Min(-2.3 dBm, Max( $P_{\text{rated,t,TRP}} - 30.3 \text{ dB}$ , -9.3 dBm))	1 MHz
$0.1 * \text{BW}_{\text{contiguous}} \leq \Delta f < \Delta f_{\text{max}}$	$0.1 * \text{BW}_{\text{contiguous}} + 0.5 \text{ MHz} \leq f_{\text{offset}} < f_{\text{offsetmax}}$	Min(-13 dBm, Max( $P_{\text{rated,t,TRP}} - 41 \text{ dB}$ , -20 dBm))	1 MHz
NOTE: For non-contiguous spectrum operation within any operating band the limit within sub-block gaps is calculated as a cumulative sum of contributions from adjacent sub blocks on each side of the sub block gap.			

**Table 6.7.4.5.2.2-3: OBUE limits applicable in the frequency range 43.5– 48.2 GHz**

Frequency offset of measurement filter -3 dB point, $\Delta f$	Frequency offset of measurement filter centre frequency, $f_{\text{offset}}$	Test limit	Measurement bandwidth
$0 \text{ MHz} \leq \Delta f < 0.1 * \text{BW}_{\text{contiguous}}$	$0.5 \text{ MHz} \leq f_{\text{offset}} < 0.1 * \text{BW}_{\text{contiguous}} + 0.5 \text{ MHz}$	Min(-2.1 dBm, Max( $P_{\text{rated,t,TRP}} - 30.1 \text{ dB}$ , -9.1 dBm))	1 MHz
$0.1 * \text{BW}_{\text{contiguous}} \leq \Delta f < \Delta f_{\text{max}}$	$0.1 * \text{BW}_{\text{contiguous}} + 0.5 \text{ MHz} \leq f_{\text{offset}} < f_{\text{offsetmax}}$	Min(-13 dBm, Max( $P_{\text{rated,t,TRP}} - 41 \text{ dB}$ , -20 dBm))	1 MHz
NOTE: For non-contiguous spectrum operation within any operating band the limit within sub-block gaps is calculated as a cumulative sum of contributions from adjacent sub blocks on each side of the sub block gap.			

**Table 6.7.4.5.2.2-4: OBUE limits applicable in the frequency range 52.6 – 71 GHz**

Frequency offset of measurement filter -3B point, $\Delta f$	Frequency offset of measurement filter centre frequency, $f_{\text{offset}}$	Limit	Measurement bandwidth
$0 \text{ MHz} \leq \Delta f < 0.1 * \text{BW}_{\text{contiguous}}$	$0.5 \text{ MHz} \leq f_{\text{offset}} < 0.1 * \text{BW}_{\text{contiguous}} + 0.5 \text{ MHz}$	Min(-0.3 dBm, Max( $P_{\text{rated,t,TRP}} - 26.3 \text{ dB}$ , - 7.3 dBm))	1 MHz
$0.1 * \text{BW}_{\text{contiguous}} \leq \Delta f < \Delta f_{\text{max}}$	$0.1 * \text{BW}_{\text{contiguous}} + 0.5 \text{ MHz} \leq f_{\text{offset}} < f_{\text{offsetmax}}$	Min(-13 dBm, Max( $P_{\text{rated,t,TRP}} - 39 \text{ dB}$ , -20 dBm))	1 MHz
NOTE: For <i>non-contiguous spectrum</i> operation within any <i>operating band</i> the limit within <i>sub-block gaps</i> is calculated as a cumulative sum of contributions from adjacent <i>sub-blocks</i> on each side of the <i>sub-block gap</i> .			

### 6.7.4.5.2.3 OTA operating band unwanted emission limits (Category B)

The power of unwanted emission shall not exceed the limits in table 6.7.4.5.2.3-1, 6.7.4.5.2.3-2 or 6.7.4.5.2.3-3.

Table 6.7.4.5.2.3-1: OBUE limits applicable in the frequency range 24.25 – 33.4 GHz

Frequency offset of measurement filter -3 dB point, $\Delta f$	Frequency offset of measurement filter centre frequency, $f_{\text{offset}}$	Test limit	Measurement bandwidth
$0 \text{ MHz} \leq \Delta f < 0.1 * \text{BW}_{\text{contiguous}}$	$0.5 \text{ MHz} \leq f_{\text{offset}} < 0.1 * \text{BW}_{\text{contiguous}} + 0.5 \text{ MHz}$	Min(-2.3 dBm, Max( $P_{\text{rated,t,TRP}} - 32.3 \text{ dB}$ , -9.3 dBm))	1 MHz
$0.1 * \text{BW}_{\text{contiguous}} \leq \Delta f < \Delta f_{\text{B}}$	$0.1 * \text{BW}_{\text{contiguous}} + 0.5 \text{ MHz} \leq f_{\text{offset}} < \Delta f_{\text{B}} + 0.5 \text{ MHz}$	Min(-13 dBm, Max( $P_{\text{rated,t,TRP}} - 43 \text{ dB}$ , -20 dBm))	1 MHz
$\Delta f_{\text{B}} \leq \Delta f < \Delta f_{\text{max}}$	$\Delta f_{\text{B}} + 5 \text{ MHz} \leq f_{\text{offset}} < f_{\text{offset}_{\text{max}}}$	Min(-5 dBm, Max( $P_{\text{rated,t,TRP}} - 33 \text{ dB}$ , -10 dBm))	10 MHz
NOTE 1: For non-contiguous spectrum operation within any <i>operating band</i> the limit within sub-block gaps is calculated as a cumulative sum of contributions from adjacent sub blocks on each side of the sub block gap, where the contribution from the far-end sub-block shall be scaled according to the measurement bandwidth of the near-end sub-block.			
NOTE 2: $\Delta f_{\text{B}} = 2 * \text{BW}_{\text{contiguous}}$ when $\text{BW}_{\text{contiguous}} \leq 500 \text{ MHz}$ , otherwise $\Delta f_{\text{B}} = \text{BW}_{\text{contiguous}} + 500 \text{ MHz}$ .			

Table 6.7.4.5.2.3-2: OBUE limits applicable in the frequency range 37 – 43.5 GHz

Frequency offset of measurement filter -3 dB point, $\Delta f$	Frequency offset of measurement filter centre frequency, $f_{\text{offset}}$	Test limit	Measurement bandwidth
$0 \text{ MHz} \leq \Delta f < 0.1 * \text{BW}_{\text{contiguous}}$	$0.5 \text{ MHz} \leq f_{\text{offset}} < 0.1 * \text{BW}_{\text{contiguous}} + 0.5 \text{ MHz}$	Min(-2.3 dBm, Max( $P_{\text{rated,t,TRP}} - 30.3 \text{ dB}$ , -9.3 dBm))	1 MHz
$0.1 * \text{BW}_{\text{contiguous}} \leq \Delta f < \Delta f_{\text{B}}$	$0.1 * \text{BW}_{\text{contiguous}} + 0.5 \text{ MHz} \leq f_{\text{offset}} < \Delta f_{\text{B}} + 0.5 \text{ MHz}$	Min(-13 dBm, Max( $P_{\text{rated,t,TRP}} - 41 \text{ dB}$ , -20 dBm))	1 MHz
$\Delta f_{\text{B}} \leq \Delta f < \Delta f_{\text{max}}$	$\Delta f_{\text{B}} + 5 \text{ MHz} \leq f_{\text{offset}} < f_{\text{offset}_{\text{max}}}$	Min(-5 dBm, Max( $P_{\text{rated,t,TRP}} - 31 \text{ dB}$ , -10 dBm))	10 MHz
NOTE 1: For non-contiguous spectrum operation within any <i>operating band</i> the limit within sub-block gaps is calculated as a cumulative sum of contributions from adjacent sub blocks on each side of the sub block gap, where the contribution from the far-end sub-block shall be scaled according to the measurement bandwidth of the near-end sub-block.			
NOTE 2: $\Delta f_{\text{B}} = 2 * \text{BW}_{\text{contiguous}}$ when $\text{BW}_{\text{contiguous}} \leq 500 \text{ MHz}$ , otherwise $\Delta f_{\text{B}} = \text{BW}_{\text{contiguous}} + 500 \text{ MHz}$ .			

Table 6.7.4.5.2.3-3: OBUE limits applicable in the frequency range 43.5 – 48.2 GHz

Frequency offset of measurement filter -3 dB point, $\Delta f$	Frequency offset of measurement filter centre frequency, $f_{\text{offset}}$	Test limit	Measurement bandwidth
$0 \text{ MHz} \leq \Delta f < 0.1 * \text{BW}_{\text{contiguous}}$	$0.5 \text{ MHz} \leq f_{\text{offset}} < 0.1 * \text{BW}_{\text{contiguous}} + 0.5 \text{ MHz}$	Min(-2.1 dBm, Max( $P_{\text{rated,t,TRP}} - 30.1 \text{ dB}$ , -9.1 dBm))	1 MHz
$0.1 * \text{BW}_{\text{contiguous}} \leq \Delta f < \Delta f_{\text{B}}$	$0.1 * \text{BW}_{\text{contiguous}} + 0.5 \text{ MHz} \leq f_{\text{offset}} < \Delta f_{\text{B}} + 0.5 \text{ MHz}$	Min(-13 dBm, Max( $P_{\text{rated,t,TRP}} - 41 \text{ dB}$ , -20 dBm))	1 MHz
$\Delta f_{\text{B}} \leq \Delta f < \Delta f_{\text{max}}$	$\Delta f_{\text{B}} + 5 \text{ MHz} \leq f_{\text{offset}} < f_{\text{offset}_{\text{max}}}$	Min(-5 dBm, Max( $P_{\text{rated,t,TRP}} - 31 \text{ dB}$ , -10 dBm))	10 MHz
NOTE 1: For non-contiguous spectrum operation within any <i>operating band</i> the limit within sub-block gaps is calculated as a cumulative sum of contributions from adjacent sub blocks on each side of the sub block gap, where the contribution from the far-end sub-block shall be scaled according to the measurement bandwidth of the near-end sub-block.			
NOTE 2: $\Delta f_{\text{B}} = 2 * \text{BW}_{\text{contiguous}}$ when $\text{BW}_{\text{contiguous}} \leq 500 \text{ MHz}$ , otherwise $\Delta f_{\text{B}} = \text{BW}_{\text{contiguous}} + 500 \text{ MHz}$ .			

Table 6.7.4.5.2.3-4: OBUE limits applicable in the frequency range 52.6 – 71 GHz

Frequency offset of measurement filter -3 dB point, $\Delta f$	Frequency offset of measurement filter centre frequency, $f_{\text{offset}}$	Limit	Measurement bandwidth
$0 \text{ MHz} \leq \Delta f < 0.1 * \text{BW}_{\text{contiguous}}$	$0.5 \text{ MHz} \leq f_{\text{offset}} < 0.1 * \text{BW}_{\text{contiguous}} + 0.5 \text{ MHz}$	Min(-0.3 dBm, Max( $P_{\text{rated,t,TRP}} - 26.3 \text{ dB}$ , -7.3 dBm))	1 MHz
$0.1 * \text{BW}_{\text{contiguous}} \leq \Delta f < \Delta f_{\text{B}}$	$0.1 * \text{BW}_{\text{contiguous}} + 0.5 \text{ MHz} \leq f_{\text{offset}} < \Delta f_{\text{B}} + 0.5 \text{ MHz}$	Min(-13 dBm, Max( $P_{\text{rated,t,TRP}} - 39 \text{ dB}$ , -20 dBm))	1 MHz
$\Delta f_{\text{B}} \leq \Delta f < \Delta f_{\text{max}}$	$\Delta f_{\text{B}} + 5 \text{ MHz} \leq f_{\text{offset}} < f_{\text{offset}_{\text{max}}}$	Min(-5 dBm, Max( $P_{\text{rated,t,TRP}} - 29 \text{ dB}$ , -10 dBm))	10 MHz
NOTE 1: For non-contiguous spectrum operation within any <i>operating band</i> the limit within sub-block gaps is calculated as a cumulative sum of contributions from adjacent sub-blocks on each side of the sub-block gap, where the contribution from the far-end sub-block shall be scaled according to the measurement bandwidth of the near-end sub-block.			
NOTE 2: $\Delta f_{\text{B}} = 2 * \text{BW}_{\text{contiguous}}$ when $\text{BW}_{\text{contiguous}} \leq 500 \text{ MHz}$ , otherwise $\Delta f_{\text{B}} = \text{BW}_{\text{contiguous}} + 500 \text{ MHz}$ .			

#### 6.7.4.5.2.4 Additional OTA operating band unwanted emission limits

##### 6.7.4.5.2.4.1 Protection of Earth Exploration Satellite Service

For BS operating in the frequency range 24.25 – 27.5 GHz, the power of unwanted emission shall not exceed the limits in table 6.7.4.5.2.4.1-1.

Table 6.7.4.5.2.4.1-1: BS radiated limits for protection of EESS

Frequency range	Measurement filter centre frequency range	Limit	Measurement Bandwidth
23.6 – 24 GHz	23.7 – 23.9 GHz	-3 dBm (Note 1)	200 MHz
23.6 – 24 GHz	23.7 – 23.9 GHz	-9 dBm (Note 2)	200 MHz
NOTE 1: This limit applies to BS brought into use on or before 1 September 2027.			
NOTE 2: This limit applies to BS brought into use after 1 September 2027.			

## 6.7.5 OTA transmitter spurious emissions

### 6.7.5.1 General

Unless otherwise stated, all requirements are measured as mean power.

The OTA transmitter spurious emissions limits are specified as TRP per RIB, unless otherwise stated.

The OTA transmitter spurious emission limits for FR1 shall apply from 30 MHz to 12.75 GHz, excluding the frequency range from  $\Delta f_{\text{OBUE}}$  below the lowest frequency of each supported downlink *operating band*, up to  $\Delta f_{\text{OBUE}}$  above the highest frequency of each supported downlink *operating band*, where the  $\Delta f_{\text{OBUE}}$  is defined in clause 6.7.1. For some *operating bands*, the upper limit of the spurious range might be higher than 12.75 GHz in order to comply with the 5<sup>th</sup> harmonic limit of the downlink *operating band*, as specified in ITU-R recommendation SM.329 [5].

For *multi-band RIB* each supported *operating band* and the  $\Delta f_{\text{OBUE}}$  MHz around each band are excluded from the OTA transmitter spurious emissions requirements.

Additional limits in clause 6.7.5.4.5 may apply closer than  $\Delta f_{\text{OBUE}}$  from the edges of *downlink operating band*.

The requirements shall apply whatever the type of transmitter considered (single carrier or multi-carrier). It applies for all transmission modes foreseen by the manufacturer's specification.

*BS type I-O* requirements consists of OTA transmitter spurious emission requirements based on TRP and co-location requirements not based on TRP.

The OTA transmitter spurious emission limits for FR2 shall apply from 30 MHz to 2<sup>nd</sup> harmonic of the upper frequency edge of the downlink *operating band*, excluding the frequency range from  $\Delta f_{\text{OBUE}}$  below the lowest frequency of each supported downlink *operating band*, up to  $\Delta f_{\text{OBUE}}$  above the highest frequency of each supported downlink *operating band*, where the  $\Delta f_{\text{OBUE}}$  is defined in clause 6.7.1.

## 6.7.5.2 General OTA transmitter spurious emissions requirements

### 6.7.5.2.1 Definition and applicability

The general OTA transmitter spurious emissions requirements are specified as TRP per RIB, per cell, unless otherwise specified.

### 6.7.5.2.2 Minimum requirement

The minimum requirement for *BS type 1-O* is specified in TS 38.104 [2], clause 9.7.5.2.2.

The minimum requirement for *BS type 2-O* is specified in TS 38.104 [2], clause 9.7.5.3.2.

### 6.7.5.2.3 Test purpose

The test purpose is to verify if the radiated spurious emissions from the BS at the RIB are within the specified minimum requirements.

### 6.7.5.2.4 Method of test

#### 6.7.5.2.4.1 Initial conditions

Test environment: Normal; see annex B.2.

RF channels to be tested for single carrier, see clause 4.9.1:

- For FR1:
  - B when testing from 30 MHz to  $F_{\text{DL\_low}} - \Delta f_{\text{OBUE}}$
  - T when testing from  $F_{\text{DL\_high}} + \Delta f_{\text{OBUE}}$  to 12.75 GHz (or to 5<sup>th</sup> harmonic)
- For FR2:
  - B when testing from 30 MHz to  $F_{\text{DL\_low}} - \Delta f_{\text{OBUE}}$
  - T when testing from  $F_{\text{DL\_high}} + \Delta f_{\text{OBUE}}$  to 2<sup>nd</sup> harmonic (or to 60 GHz)

RF bandwidth positions to be tested in single-band multi-carrier operation, see clause 4.9.1:

- For FR1:
  - $B_{\text{RFBW}}$  when testing from 30 MHz to  $F_{\text{DL\_low}} - \Delta f_{\text{OBUE}}$
  - $T_{\text{RFBW}}$  when testing from  $F_{\text{DL\_high}} + \Delta f_{\text{OBUE}}$  to 12.75 GHz (or 5<sup>th</sup> harmonic)
- For FR2:
  - $B_{\text{RFBW}}$  when testing from 30 MHz to  $F_{\text{DL\_low}} - \Delta f_{\text{OBUE}}$
  - $T_{\text{RFBW}}$  when testing from  $F_{\text{DL\_high}} + \Delta f_{\text{OBUE}}$  to 2<sup>nd</sup> harmonic (or to 60 GHz)

RF bandwidth positions to be tested in multi-band multi-carrier operation, see clause 4.9.1:

- For FR1:
  - $B_{\text{RFBW\_T'RFBW}}$  when testing from 30 MHz to  $F_{\text{DL\_Blow\_low}} - \Delta f_{\text{OBUE}}$
  - $B'_{\text{RFBW\_T'RFBW}}$  when testing from  $F_{\text{DL\_Bhigh\_high}} + \Delta f_{\text{OBUE}}$  to 12.75 GHz (or to 5<sup>th</sup> harmonic)

- $B_{\text{RFBW}_T^{\text{RFBW}}}$  and  $B_{\text{RFBW}_T^{\text{RFBW}}}$  when testing from  $F_{\text{DL\_Blow\_high}} + \Delta f_{\text{OBUE}}$  to  $F_{\text{DL\_Bhigh\_low}} - \Delta f_{\text{OBUE}}$

Directions to be tested: As the requirement is TRP the beam pattern(s) may be set up to optimise the TRP measurement procedure (see annex I).

#### 6.7.5.2.4.2 Procedure

The following procedure for measuring TRP is based on directional power measurements as described in annex I. An alternative method to measure TRP is to use a characterized and calibrated reverberation chamber. If so, follow steps 1, 3, 4, 5, 7 and 10. When calibrated and operated within the guidance of 3GPP TR 37.941 [29] the measurement methods are applicable and selected depending on availability at the test facility.

- 1) Place the BS at the positioner.
- 2) Align the manufacturer declared coordinate system orientation (D.2) of the BS with the test system.
- 3) Measurements shall use a measurement bandwidth in accordance to the conditions in clause 6.7.5.2.5.
- 4) The measurement device characteristics shall be:
  - Detection mode: True RMS.
  - The emission power should be averaged over an appropriate time duration to ensure the measurement is within the measurement uncertainty in Table 4.1.2.2-1 for FR1 and Table 4.1.2.2-2 for FR2.
- 5) Set the BS to transmit:
  - For RIB declared to be capable of single carrier operation only, set the RIB to transmit a signal according to the applicable test configuration in clause 4.8 using the corresponding test model in clause 4.9.2 (i.e. NR-FR1-TM1.1 for *BS type 1-O* and NR-FR2-TM1.1 for *BS type 2-O*), at manufacturer's declared rated output power  $P_{\text{rated,c,TRP}}$ .
  - For a RIB declared to be capable of multi-carrier and/or CA operation, set the RIB to transmit according to the corresponding test model in clause 4.9.2 on all carriers configured using the applicable test configuration and corresponding power setting specified in clause 4.7.2 and 4.8.
- 6) Orient the positioner (and BS) in order that the direction to be tested aligns with the test antenna such that measurements to determine TRP can be performed (see annex I).
- 7) Measure the emission at the specified frequencies with specified measurement bandwidth.
- 8) Repeat step 6-7 for all directions in the appropriated TRP measurement grid needed for full TRP estimation (see annex I).

NOTE 1: The TRP measurement grid may not be the same for all measurement frequencies.

NOTE 2: The frequency sweep or the TRP measurement grid sweep may be done in any order.

- 9) Calculate TRP at each specified frequency using the directional measurements.

In addition, for *multi-band RIB(s)*, the following steps shall apply:

- 10) For *BS type 1-O* and *multi-band RIBs* and single band tests, repeat the steps above per involved band where single band test configurations and test models shall apply with no carrier activated in the other band.

#### 6.7.5.2.5 Test requirement

##### 6.7.5.2.5.1 Test requirement for *BS type 1-O*

For a BS meeting category A the TRP of any spurious emission shall not exceed the limits in table 6.7.5.2.5.1-1.

**Table 6.7.5.2.5.1-1: General OTA BS transmitter spurious emission limits for *BS type 1-O*, Category A**

Spurious frequency range	Test limit	Measurement bandwidth	Notes
30 MHz – 1 GHz	-13 + X dBm	100 kHz	Note 1, Note 6
1 GHz – 12.75 GHz		1 MHz	Note 1, Note 2, Note 6
12.75 GHz – 5 <sup>th</sup> harmonic of the upper frequency edge of the DL <i>operating band</i> in GHz		1 MHz	Note 1, Note 2, Note 3, Note 6
12.75 GHz - 26 GHz	-13 + X dBm	1 MHz	Note 1, Note 2, Note 6, Note 7
NOTE 1: Measurement bandwidths as in ITU-R SM.329 [5], s4.1. NOTE 2: Upper frequency as in ITU-R SM.329 [5], s2.5 table 1. NOTE 3: Applies for Band for which the upper frequency edge of the DL <i>operating band</i> is greater than 2.55 GHz and less than or equal to 5.2 GHz. NOTE 4: Void. NOTE 5: Void. NOTE 6: X = 9 dB, unless stated differently in regional regulation. NOTE 7: Applies for Band for which the upper frequency edge of the DL <i>operating band</i> is greater than 5.2 GHz.			

For a BS meeting category B the TRP of any spurious emission shall not exceed the limits in table 6.7.5.2.5.1-2.

**Table 6.7.5.2.5.1-2: General OTA BS transmitter spurious emission limits for *BS type 1-O*, Category B**

Spurious frequency range	Test limit	Measurement bandwidth	Notes
30 MHz – 1 GHz	-36 + X dBm	100 kHz	Note 1, Note 5
1 GHz – 12.75 GHz	-30 + X dBm	1 MHz	Note 1, Note 2, Note 5
12.75 GHz – 5 <sup>th</sup> harmonic of the upper frequency edge of the DL <i>operating band</i> in GHz		1 MHz	Note 1, Note 2, Note 3, Note 5
12.75 GHz - 26 GHz	-30 + X dBm	1 MHz	Note 1, Note 2, Note 5, Note 6
NOTE 1: Measurement bandwidths as in ITU-R SM.329 [5], s4.1. NOTE 2: Upper frequency as in ITU-R SM.329 [5], s2.5 table 1. NOTE 3: Applies for Band for which the upper frequency edge of the DL <i>operating band</i> is greater than 2.55 GHz and less than or equal to 5.2 GHz. NOTE 4: Void. NOTE 5: X = 9 dB, unless stated differently in regional regulation. NOTE 6: Applies for Band for which the upper frequency edge of the DL <i>operating band</i> is greater than 5.2 GHz.			

#### 6.7.5.2.5.2 Test requirement for *BS type 2-O*

##### 6.7.5.2.5.2.1 General

The requirements of either clause 6.7.5.2.5.2.2 (Category A limits) or clause 6.7.5.2.5.2.3 (Category B limits) shall apply. The application of either Category A or Category B limits shall be the same as for Operating band unwanted emissions in clause 6.7.1.

**Table 6.7.5.2.5.2-1: Void**

NOTE: Table 6.7.5.2.5.2-1 is moved to clause 6.7.5.2.5.2.2 as table 6.7.5.2.5.2.2-1.

##### 6.7.5.2.5.2.2 OTA transmitter spurious emissions (Category A)

The power of any spurious emission shall not exceed the limits in table 6.7.5.2.5.2-1.



**Table 6.7.5.2.5.2.2-1: General OTA BS transmitter spurious emission limits for BS type 2-O**

Spurious frequency range	Test limit	Measurement bandwidth	Notes
30 MHz – 1 GHz	-13 dBm	100 kHz	Note 1
1 GHz – min(2 <sup>nd</sup> harmonic of the upper frequency edge of the DL operating band in GHz; 60 GHz)		1 MHz	Note 1, Note 2
NOTE 1: Measurement bandwidth as in ITU-R SM.329 [5], s4.1.			
NOTE 2: Upper frequency as in ITU-R SM.329 [5], s2.5 table 1.			

### 6.7.5.2.5.2.3 OTA transmitter spurious emissions (Category B)

The power of any spurious emission shall not exceed the limits in table 6.7.5.2.5.2.3-1.

**Table 6.7.5.2.5.2.3-1: BS radiated Tx spurious emission limits in FR2 (Category B)**

Frequency range (Note 4)	Test limit	Measurement Bandwidth	Note
30 MHz ↔ 1 GHz	-36 dBm	100 kHz	Note 1
1 GHz ↔ 18 GHz	-30 dBm	1 MHz	Note 1
18 GHz ↔ $F_{\text{step},1}$	-20 dBm	10 MHz	Note 2
$F_{\text{step},1}$ ↔ $F_{\text{step},2}$	-15 dBm	10 MHz	Note 2
$F_{\text{step},2}$ ↔ $F_{\text{step},3}$	-10 dBm	10 MHz	Note 2
$F_{\text{step},4}$ ↔ $F_{\text{step},5}$	-10 dBm	10 MHz	Note 2
$F_{\text{step},5}$ ↔ $F_{\text{step},6}$	-15 dBm	10 MHz	Note 2
$F_{\text{step},6}$ ↔ min(2 <sup>nd</sup> harmonic of the upper frequency edge of the DL operating band in GHz; 60 GHz)	-20 dBm	10 MHz	Note 2, Note 3
NOTE 1: Bandwidth as in ITU-R SM.329 [5], s4.1			
NOTE 2: Limit and bandwidth as in ERC Recommendation 74-01 [26], annex 2.			
NOTE 3: Upper frequency as in ITU-R SM.329 [5], s2.5 table 1.			
NOTE 4: The step frequencies $F_{\text{step},X}$ are defined in table 6.7.5.2.5.2.3-2.			

**Table 6.7.5.2.5.2.3-2: Step frequencies for defining the BS radiated Tx spurious emission limits in FR2 (Category B)**

Operating band	$F_{\text{step},1}$ (GHz)	$F_{\text{step},2}$ (GHz)	$F_{\text{step},3}$ (GHz) (Note 2)	$F_{\text{step},4}$ (GHz) (Note 2)	$F_{\text{step},5}$ (GHz)	$F_{\text{step},6}$ (GHz)
n257	18	23.5	25	31	32.5	41.5
n258	18	21	22.75	29	30.75	40.5
n259	23.5	35.5	38	45	47.5	59.5
NOTE 1: $F_{\text{step},X}$ are based on ERC Recommendation 74-01 [26], annex 2.						
NOTE 2: $F_{\text{step},3}$ and $F_{\text{step},4}$ are aligned with the values for $\Delta f_{\text{OBUe}}$ in table 6.7.1-1.						

## 6.7.5.3 Protection of the BS receiver of own or different BS

### 6.7.5.3.1 Definition and applicability

This requirement shall be applied for NR FDD operation in order to prevent the receivers of own or a different BS of the same band being desensitised by emissions from a BS type I-O.

This requirement is a co-location requirement as defined in clause 4.9, in TS 38.104 [2], the power levels are specified at the CLTA output.

### 6.7.5.3.2 Minimum requirements

The minimum requirement for BS type I-O is defined in TS 38.104 [2], clause 9.7.5.2.

### 6.7.5.3.3 Test purpose

For OTA co-location spurious emission, the test purpose is to verify that the emission is within the specified requirement limits at the CLTA conducted output(s).

### 6.7.5.3.4 Method of test

#### 6.7.5.3.4.1 Initial conditions

Test environment: Normal; see annex B.2.

RF channels to be tested for single carrier:  $M$ ; see clause 4.9.1.

*Base Station RF Bandwidth* positions to be tested for multi-carrier:

- $M_{\text{RFBW}}$  in *single-band RIB*, see clause 4.9.1;
- $B_{\text{RFBW}_T}$  and  $B'_{\text{RFBW}_T}$  in *multi-band RIB*, see clause 4.9.1.

In addition, for *multi-band RIB*:

- For  $B_{\text{RFBW}_T}$ , emission testing above the highest operating band may be omitted.
- For  $B'_{\text{RFBW}_T}$ , emission testing below the lowest operating band may be omitted.

Directions to be tested: The requirement is specified as co-location requirement. For general description of co-location requirements, refer to clause 4.12.

The co-location spurious emission is measured at the CLTA conducted output(s).

#### 6.7.5.3.4.2 Procedure

- 1) Select and place the NR BS and CLTA as described in clause 4.12 with parameters as specified in table 4.12.2.2-1 and table 4.12.2.3-1.
- 2) Several CLTAs might be required to cover the whole co-location spurious emission frequency ranges.
- 3) Place test antenna in reference direction at far-field distance, aligned in all supported polarizations (single or dual) with the NR BS as depicted in annex E.1.3.
- 4) The test antenna shall be dual (or single) polarized with the same frequency range as the NR BS for co-location spurious emission test case.
- 5) Connect test antenna and CLTA to the measurement equipment as depicted in annex E.1.3.
- 6) OTA co-location spurious emission is measured as the power sum over all supported polarizations at the CLTA conducted output(s).
- 7) The measurement device (signal analyzer) characteristics shall be:
  - Detection mode: True RMS.

The emission power should be averaged over an appropriate time duration to ensure the measurement is within the measurement uncertainty in Table 4.1.2.2-1.

- 8) Set the *BS type I-O* to transmit:
  - Set the NR BS to transmit maximum power according to the applicable test configuration in clause 4.8 using the corresponding test models or set of physical channels in clause 4.9.2.
  - For the NR BS declared to be capable of multi-carrier and/or CA operation, set the BS to transmit according to NR-FR1-TM1.1 on all carriers configured using the applicable test configuration and corresponding power setting specified in clause 4.7.2 and 4.8.
- 9) Measure the emission at the specified frequencies with specified measurement bandwidth.

NOTE: An alternative measurement method to be used for measuring the OTA emission is described in annex K.

In addition, for *multi-band RIB*, the following steps shall apply:

- 10) For *multi-band RIB* and single band tests, repeat the steps above per involved band where single band test configurations and test models shall apply with no carrier activated in the other band.

### 6.7.5.3.5 Test requirements

#### 6.7.5.3.5.1 Test requirement for *BS type 1-O*

This requirement shall be applied for NR FDD operation in order to prevent the receivers of own or a different BS of the same band being desensitised by emissions from a *BS type 1-O*.

This requirement is a co-location requirement as defined in clause 4.9, in TS 38.104 [2], the power levels are specified at the CLTA output.

The total power of any spurious emission from both polarizations of the CLTA connector output shall not exceed the limits in table 6.7.5.3.5.1-1.

**Table 6.7.5.3.5.1-1: *BS type 1-O* OTA spurious emissions limits for protection of the BS receiver**

BS class	Frequency range	Maximum Level for bands below 3GHz	Maximum Level for bands between 3 and 4.2GHz	Maximum Level for bands between 4.2 and 7.125 GHz	Measurement bandwidth
Wide Area BS	$F_{UL\_low} - F_{UL\_high}$	-113.9 dBm	-113.7 dBm	-113.6 dBm	100 kHz
Medium Range BS		-108.9 dBm	-108.7 dBm	-108.6 dBm	
Local Area BS		-105.9 dBm	-105.7 dBm	-105.6 dBm	
NOTE 1: For BS operating in regions where a band is only partially allocated for NR operations (e.g. band n28), this requirement only applies in the UL frequency range of the partial allocation. NOTE 2: For BS capable of multi-band operation, Table 6.7.5.3.5.1-1 assumes that the supported <i>operating bands</i> , where the corresponding BS transmit and receive frequency ranges in table 5.2-1 in TS 38.104 [2] would be overlapping, are not deployed in the same geographical area. For such a case of operation with overlapping frequency arrangements in the same geographical area, special protection requirements may apply that are not covered by the 3GPP specifications.					

### 6.7.5.4 Additional spurious emissions requirements

#### 6.7.5.4.1 Definition and applicability

These requirements may be applied for the protection of systems operating in frequency ranges other than the BS downlink operating band. The limits may apply as an optional protection of such systems that are deployed in the same geographical area as the BS, or they may be set by local or regional regulation as a mandatory requirement for an NR operating band. It is in some cases not stated in the present document whether a requirement is mandatory or under what exact circumstances that a limit applies, since this is set by local or regional regulation. An overview of regional requirements in the present document is given in clause 4.4.

Some requirements may apply for the protection of specific equipment (UE, MS and/or BS) or equipment operating in specific systems (GSM, CDMA, UTRA, E-UTRA, NR, etc.).

The requirement shall apply at each RIB supporting transmission in the *operating band*.

All additional spurious requirements are TRP unless otherwise stated.

#### 6.7.5.4.2 Minimum Requirement

The minimum requirement for *BS type 1-O* is specified in TS 38.104 [2], clause 9.7.5.2.4.

The minimum requirement for *BS type 2-O* is specified in TS 38.104 [2], clause 9.7.5.3.3.

### 6.7.5.4.3 Test purpose

The test purpose is to verify the radiated spurious emissions from the BS at the RIB are within the specified additional spurious emissions requirements.

### 6.7.5.4.4 Method of test

#### 6.7.5.4.4.1 Initial conditions

Test environment: Normal; see annex B.2.

RF channels to be tested for single carrier:

- For FR1:
  - B when testing from 30 MHz to  $F_{DL\_low} - \Delta f_{OBUE}$
  - T when testing from  $F_{DL\_high} + \Delta f_{OBUE}$  to 12.75 GHz (or to 5<sup>th</sup> harmonic)
- For FR2:
  - B when testing from 30 MHz to  $F_{DL\_low} - \Delta f_{OBUE}$
  - T when testing from  $F_{DL\_high} + \Delta f_{OBUE}$  to 60 GHz (or to 2<sup>nd</sup> harmonic)

RF bandwidth positions to be tested in single-band multi-carrier operation:

- For FR1:
  - $B_{RFBW}$  when testing from 30 MHz to  $F_{DL\_low} - \Delta f_{OBUE}$
  - $T_{RFBW}$  when testing from  $F_{DL\_high} + \Delta f_{OBUE}$  to 12.75 GHz (or to 5<sup>th</sup> harmonic)
- For FR2:
  - $B_{RFBW}$  when testing from 30 MHz to  $F_{DL\_low} - \Delta f_{OBUE}$
  - $T_{RFBW}$  when testing from  $F_{DL\_high} + \Delta f_{OBUE}$  to 60 GHz (or to 2<sup>nd</sup> harmonic)

RF bandwidth positions to be tested in multi-band multi-carrier operation:

- For FR1:
  - $B_{RFBW\_T'RFBW}$  when testing from 30 MHz to  $F_{DL\_Blow\_low} - \Delta f_{OBUE}$
  - $B'_{RFBW\_T'RFBW}$  when testing from  $F_{DL\_Bhigh\_high} + \Delta f_{OBUE}$  to 12.75 GHz (or to 5<sup>th</sup> harmonic)
  - $B_{RFBW\_T'RFBW}$  and  $B'_{RFBW\_T'RFBW}$  when testing from  $F_{DL\_Blow\_high} + \Delta f_{OBUE}$  to  $F_{DL\_Bhigh\_low} - \Delta f_{OBUE}$

Directions to be tested: As the requirements are TRP the beam pattern(s) may be set up to optimise the TRP measurement procedure (see annex I).

#### 6.7.5.4.4.2 Procedure

The following procedure for measuring TRP is based on the directional power measurements as described in annex I. An alternative method to measure TRP is to use a characterized and calibrated reverberation chamber. If so, follow steps 1, 3, 4, 5, 7 and 10. When calibrated and operated within the guidance of 3GPP TR 37.941 [29] the measurement methods are applicable and selected depending on availability at the test facility.1) Place the BS at the positioner.

- 2) Align the manufacturer declared coordinate system orientation (D.2) of the BS with the test system.
- 3) Measurements shall use a measurement bandwidth in accordance to the conditions in clause 6.7.5.4.5.
- 4) The measurement device characteristics shall be:
  - Detection mode: True RMS.

- The emission power should be averaged over an appropriate time duration to ensure the measurement is within the measurement uncertainty in Table 4.1.2.2-1 for FR1 and Table 4.1.2.2-2 for FR2.
- 5) Set the BS to transmit:
- For RIB declared to be capable of single carrier operation only, set the RIB to transmit a signal according to the applicable test configuration in clause 4.8 using the corresponding test model in clause 4.9.2 (NR-FR1-TM1.1 for *BS type 1-O* and NR-FR2-TM1.1 for *BS type 2-O*), at manufacturer's declared rated output power  $P_{\text{rated,c,TRP}}$ .
  - For a RIB declared to be capable of multi-carrier and/or CA operation, set the RIB to transmit according to NR-FR1-TM1.1 in clause 4.9.2 on all carriers configured using the applicable test configuration and corresponding power setting specified in clause 4.7.2 and 4.8.
- 6) Orient the positioner (and BS) in order that the direction to be tested aligns with the test antenna such that measurements to determine TRP can be performed (see annex I).
- 7) Measure the emission at the specified frequencies with specified measurement bandwidth.
- 8) Repeat step 6-7 for all directions in the appropriated TRP measurement grid needed for full TRP estimation (see annex I).

NOTE 1: The TRP measurement grid may not be the same for all measurement frequencies.

NOTE 2: The frequency sweep or the TRP measurement grid sweep may be done in any order.

- 9) Calculate TRP at each specified frequency using the directional measurements.

In addition, for *multi-band RIB(s)*, the following steps shall apply:

- 10) For *multi-band RIBs* and single band tests, repeat the steps above per involved band where single band test configurations and test models shall apply with no carrier activated in the other band.

#### 6.7.5.4.5 Test requirement

##### 6.7.5.4.5.1 Test requirement for *BS type 1-O*

The power of any spurious emission shall not exceed the test limits in table 6.7.5.4.5-1 for a BS where requirements for co-existence with the system listed in the first column apply. For a *multi-band RIB*, the exclusions and conditions in the Note column of table 6.7.5.4.5-1 apply for each supported *operating band*.

**Table 6.7.5.4.5-1: BS spurious emissions test limits for BS for co-existence with systems operating in other frequency bands**

System type for NR to co-exist with	Frequency range for co-existence requirement	Test limit	Measurement bandwidth	Notes
GSM900	921 – 960 MHz	-45.4 dBm	100 kHz	This requirement does not apply to BS operating in band n8.
	876 – 915 MHz	-49.4 dBm	100 kHz	For the frequency range 880-915 MHz, this requirement does not apply to BS operating in band n8, since it is already covered by the requirement in clause 6.7.5.3.
DCS1800	1805 – 1880 MHz	-35.4 dBm	100 kHz	This requirement does not apply to BS operating in band n3.
	1710 – 1785 MHz	-49.4 dBm	100 kHz	This requirement does not apply to BS operating in band n3, since it is already covered by the requirement in clause 6.7.5.3.
PCS1900	1930 – 1990 MHz	-35.4 dBm	100 kHz	This requirement does not apply to BS operating in band n2, n25 or band n70.
	1850 – 1910 MHz	-49.4 dBm	100 kHz	This requirement does not apply to BS operating in band n2 or n25 since it is already covered by the requirement in clause 6.7.5.3.
GSM850 or CDMA850	869 – 894 MHz	-45.4 dBm	100 kHz	This requirement does not apply to BS operating in band n5 or n26.
	824 – 849 MHz	-49.4 dBm	100 kHz	This requirement does not apply to BS operating in band n5 or n26, since it is already covered by the requirement in clause 6.7.5.3.
UTRA FDD Band I or E-UTRA Band 1 or NR Band n1	2110 – 2170 MHz	-40.4 dBm	1 MHz	This requirement does not apply to BS operating in band n1 or n65.
	1920 – 1980 MHz	-37.4 dBm	1 MHz	This requirement does not apply to BS operating in band n1 or n65, since it is already covered by the requirement in clause 6.7.5.3.
UTRA FDD Band II or E-UTRA Band 2 or NR Band n2	1930 – 1990 MHz	-40.4 dBm	1 MHz	This requirement does not apply to BS operating in band n2 or n70.
	1850 – 1910 MHz	-37.4 dBm	1 MHz	This requirement does not apply to BS operating in band n2, since it is already covered by the requirement in clause 6.7.5.3.
UTRA FDD Band III or E-UTRA Band 3 or NR Band n3	1805 – 1880 MHz	-40.4 dBm	1 MHz	This requirement does not apply to BS operating in band n3.
	1710 – 1785 MHz	-37.4 dBm	1 MHz	This requirement does not apply to BS operating in band n3, since it is already covered by the requirement in clause 6.7.5.3.
UTRA FDD Band IV or E-UTRA Band 4	2110 – 2155 MHz	-40.4 dBm	1 MHz	This requirement does not apply to BS operating in band n66.
	1710 – 1755 MHz	-37.4 dBm	1 MHz	This requirement does not apply to BS operating in band n66, since it is already covered by the requirement in clause 6.7.5.3.
UTRA FDD Band V or E-UTRA Band 5 or NR Band n5	869 – 894 MHz	-40.4 dBm	1 MHz	This requirement does not apply to BS operating in band n5 or n26.
	824 – 849 MHz	-37.4 dBm	1 MHz	This requirement does not apply to BS operating in band n5 or n26, since it is already covered by the requirement in clause 6.7.5.3.
UTRA FDD Band VI, XIX or E-UTRA Band 6, 18, 19 or NR Band n18	860 – 890 MHz	-40.4 dBm	1 MHz	This requirement does not apply to BS operating in band n18.
	815 – 830 MHz	-37.4 dBm	1 MHz	This requirement does not apply to BS operating in band n18, since it is already covered by the requirement in clause 6.7.5.3.
	830 – 845 MHz	-37.4 dBm	1 MHz	
UTRA FDD Band VII or E-UTRA Band 7 or NR Band n7	2620 – 2690 MHz	-40.4 dBm	1 MHz	This requirement does not apply to BS operating in band n7.
	2500 – 2570 MHz	-37.4 dBm	1 MHz	This requirement does not apply to BS operating in band n7, since it is already covered by the requirement in clause 6.7.5.3.
UTRA FDD Band VIII or E-UTRA Band 8 or NR Band n8	925 – 960 MHz	-40.4 dBm	1 MHz	This requirement does not apply to BS operating in band n8.
	880 – 915 MHz	-37.4 dBm	1 MHz	This requirement does not apply to BS operating in band n8, since it is already covered by the requirement in clause 6.7.5.3.

System type for NR to co-exist with	Frequency range for co-existence requirement	Test limit	Measurement bandwidth	Notes
UTRA FDD Band IX or E-UTRA Band 9	1844.9 – 1879.9 MHz	-40.4 dBm	1 MHz	This requirement does not apply to BS operating in band n3.
	1749.9 – 1784.9 MHz	-37.4 dBm	1 MHz	This requirement does not apply to BS operating in band n3, since it is already covered by the requirement in clause 6.7.5.3.
UTRA FDD Band X or E-UTRA Band 10	2110 – 2170 MHz	-40.4 dBm	1 MHz	This requirement does not apply to BS operating in band n66
	1710 – 1770 MHz	-37.4 dBm	1 MHz	This requirement does not apply to BS operating in band n66, since it is already covered by the requirement in clause 6.7.5.3.
UTRA FDD Band XI or XXI or E-UTRA Band 11 or 21	1475.9 – 1510.9 MHz	-40.4 dBm	1 MHz	This requirement does not apply to BS operating in Band n50, n74, n75 or n109.
	1427.9 – 1447.9 MHz	-37.4 dBm	1 MHz	This requirement does not apply to BS operating in Band n50, n51, n74, n75, n76 or n109.
	1447.9 – 1462.9 MHz	-37.4 dBm	1 MHz	This requirement does not apply to BS operating in Band n50, n74, n75 or n109.
UTRA FDD Band XII or E-UTRA Band 12 or NR Band n12	729 – 746 MHz	-40.4 dBm	1 MHz	This requirement does not apply to BS operating in band n12 or n85.
	699 – 716 MHz	-37.4 dBm	1 MHz	This requirement does not apply to BS operating in band n12 or n85, since it is already covered by the requirement in clause 6.7.5.3. For NR BS operating in n29, it applies 1 MHz below the Band n29 downlink operating band (Note 5).
UTRA FDD Band XIII or E-UTRA Band 13 or NR Band n13	746 – 756 MHz	-40.4 dBm	1 MHz	This requirement does not apply to BS operating in band n13.
	777 – 787 MHz	-37.4 dBm	1 MHz	This requirement does not apply to BS operating in band n13, since it is already covered by the requirement in clause 6.7.5.3.
UTRA FDD Band XIV or E-UTRA Band 14 or NR Band n14	758 – 768 MHz	-40.4 dBm	1 MHz	This requirement does not apply to BS operating in band n14.
	788 – 798 MHz	-37.4 dBm	1 MHz	This requirement does not apply to BS operating in band n14, since it is already covered by the requirement in clause 6.7.5.3.
E-UTRA Band 17	734 – 746 MHz	-40.4 dBm	1 MHz	
	704 – 716 MHz	-37.4 dBm	1 MHz	For NR BS operating in n29, it applies 1 MHz below the Band n29 downlink operating band (Note 5).
UTRA FDD Band XX or E-UTRA Band 20 or NR Band n20	791 – 821 MHz	-40.4 dBm	1 MHz	This requirement does not apply to BS operating in band n20 or n28.
	832 – 862 MHz	-37.4 dBm	1 MHz	This requirement does not apply to BS operating in band n20, since it is already covered by the requirement in clause 6.7.5.3.
UTRA FDD Band XXII or E-UTRA Band 22	3510 – 3590 MHz	-40 dBm	1 MHz	This requirement does not apply to BS operating in Band n77 or n78.
	3410 – 3490 MHz	-37 dBm	1 MHz	This requirement does not apply to BS operating in Band n77 or n78.
E-UTRA Band 24 or NR Band n24	1525 – 1559 MHz	-40.4 dBm	1 MHz	
	1626.5 – 1660.5 MHz	-37.4 dBm	1 MHz	
UTRA FDD Band XXV or E-UTRA Band 25 or NR band n25	1930 – 1995 MHz	-40.4 dBm	1 MHz	This requirement does not apply to BS operating in band n2, n25 or n70.
	1850 – 1915 MHz	-37.4 dBm	1 MHz	This requirement does not apply to BS operating in band n25 since it is already covered by the requirement in clause 6.7.5.3. For BS operating in Band n2, it applies for 1910 MHz to 1915 MHz, while the rest is covered in clause 6.7.5.3.
UTRA FDD Band XXVI or	859 – 894 MHz	-40.4 dBm	1 MHz	This requirement does not apply to BS operating in band n5 or n26.



System type for NR to co-exist with	Frequency range for co-existence requirement	Test limit	Measurement bandwidth	Notes
E-UTRA Band 26 or NR Band n26	814 – 849 MHz	-37.4 dBm	1 MHz	This requirement does not apply to BS operating in band n26 since it is already covered by the requirement in clause 6.7.5.3. For BS operating in Band n5, it applies for 814 MHz to 824 MHz, while the rest is covered in clause 6.7.5.3.
E-UTRA Band 27	852 – 869 MHz	-40.4 dBm	1 MHz	This requirement does not apply to BS operating in Band n5.
	807 – 824 MHz	-37.4 dBm	1 MHz	This requirement also applies to BS operating in Band n28, starting 4 MHz above the Band n28 downlink <i>operating band</i> (Note 5).
E-UTRA Band 28 or NR Band n28	758 – 803 MHz	-40.4 dBm	1 MHz	This requirement does not apply to BS operating in band n20, n67 or n28.
	703 – 748 MHz	-37.4 dBm	1 MHz	This requirement does not apply to BS operating in band n28, since it is already covered by the requirement in clause 6.7.5.3. For BS operating in band n67, it applies for 703 MHz to 736 MHz.
E-UTRA Band 29 or NR Band n29	717 – 728 MHz	-40.4 dBm	1 MHz	This requirement does not apply to BS operating in Band n29 or n85.
E-UTRA Band 30 or NR Band n30	2350 – 2360 MHz	-40.4 dBm	1 MHz	This requirement does not apply to BS operating in band n30.
	2305 – 2315 MHz	-37.4 dBm	1 MHz	This requirement does not apply to BS operating in band n30, since it is already covered by the requirement in clause 6.7.5.3.
E-UTRA Band 31 or NR Band n31	462.5 -467.5 MHz	-40.4 dBm	1 MHz	This requirement does not apply to BS operating in band n31 or n72.
	452.5 -457.5 MHz	-37.4 dBm	1 MHz	This requirement does not apply to BS operating in band n31, since it is already covered by the requirement in clause 6.7.5.3. This requirement does not apply to BS operating in band n72.
UTRA FDD band XXXII or E-UTRA band 32	1452 – 1496 MHz	-40.4 dBm	1 MHz	This requirement does not apply to BS operating in Band n50, n74, n75 or n109.
UTRA TDD Band a) or E-UTRA Band 33	1900 – 1920 MHz	-40.4 dBm	1 MHz	
UTRA TDD Band a) or E-UTRA Band 34 or NR band n34	2010 – 2025 MHz	-40.4 dBm	1 MHz	This requirement does not apply to BS operating in Band n34.
UTRA TDD Band b) or E-UTRA Band 35	1850 – 1910 MHz	-40.4 dBm	1 MHz	
UTRA TDD Band b) or E-UTRA Band 36	1930 – 1990 MHz	-40.4 dBm	1 MHz	This requirement does not apply to BS operating in Band n2 or n25.
UTRA TDD Band c) or E-UTRA Band 37	1910 – 1930 MHz	-40.4 dBm	1 MHz	
UTRA TDD Band d) or E-UTRA Band 38 or NR Band n38	2570 – 2620 MHz	-40.4 dBm	1 MHz	This requirement does not apply to BS operating in Band n38.

System type for NR to co-exist with	Frequency range for co-existence requirement	Test limit	Measurement bandwidth	Notes
UTRA TDD Band f) or E-UTRA Band 39 or NR band n39	1880 – 1920MHz	-40.4 dBm	1 MHz	This requirement does not apply to BS operating in Band n39.
UTRA TDD Band e) or E-UTRA Band 40 or NR Band n40	2300 – 2400MHz	-40.4 dBm	1 MHz	This requirement does not apply to BS operating in Bands n30 or n40.
E-UTRA Band 41 or NR Band n41	2496 – 2690 MHz	-40.4 dBm	1 MHz	This is not applicable to BS operating in Band n41.
E-UTRA Band 42	3400 – 3600 MHz	-40 dBm	1 MHz	This requirement does not apply to BS operating in Band n77 or n78.
E-UTRA Band 43	3600 – 3800 MHz	-40 dBm	1 MHz	This requirement does not apply to BS operating in Band n77 or n78.
E-UTRA Band 44	703 – 803 MHz	-40.4 dBm	1 MHz	This is not applicable to BS operating in Band n28.
E-UTRA Band 45	1447 – 1467 MHz	-40.4 dBm	1 MHz	
E-UTRA Band 46 or NR Band n46	5150 – 5925 MHz	-39.5 dBm	1 MHz	
E-UTRA Band 47	5855 – 5925 MHz	-39.5 dBm	1 MHz	
E-UTRA Band 48	3550 – 3700 MHz	-40 dBm	1 MHz	This requirement does not apply to BS operating in Band n77 or n78.
E-UTRA Band 50 or NR Band n50	1432 – 1517 MHz	-40.4 dBm	1 MHz	This requirement does not apply to BS operating in Band n50, n51, n74, n75, n76 or n109.
E-UTRA Band 51 or NR Band n51	1427 – 1432 MHz	-40.4 dBm	1 MHz	This requirement does not apply to BS operating in Band n50, n51, n75, n76 or n109.
E-UTRA Band 53 or NR Band n53	2483.5 - 2495 MHz	-40.4 dBm	1 MHz	This requirement does not apply to BS operating in Band n41 or n90.
E-UTRA Band 54 or NR Band n54	1670 - 1675 MHz	-40.4 dBm	1 MHz	This requirement does not apply to BS operating in Band n54
E-UTRA Band 65 or NR Band n65	2110 – 2200 MHz	-40.4 dBm	1 MHz	This requirement does not apply to BS operating in band n1 or n65.
	1920 – 2010 MHz	-37.4 dBm	1 MHz	For BS operating in Band n1, it applies for 1980 MHz to 2010 MHz, while the rest is covered in clause 6.7.5.3. This requirement does not apply to BS operating in band n65, since it is already covered by the requirement in clause 6.7.5.3.
E-UTRA Band 66 or NR Band n66	2110 – 2200 MHz	-40.4 dBm	1 MHz	This requirement does not apply to BS operating in band n66.
	1710 – 1780 MHz	-37.4 dBm	1 MHz	This requirement does not apply to BS operating in band n66, since it is already covered by the requirement in clause 6.7.5.3.
E-UTRA Band 67 or NR Band n67	738 – 758 MHz	-40.4 dBm	1 MHz	This requirement does not apply to BS operating in Band n28 or n67.
E-UTRA Band 68	753 - 783 MHz	-40.4 dBm	1 MHz	This requirement does not apply to BS operating in band n28.
	698-728 MHz	-37.4 dBm	1 MHz	For BS operating in Band n28, this requirement applies between 698 MHz and 703 MHz, while the rest is covered in clause 6.7.5.3.
E-UTRA Band 69	2570 – 2620 MHz	-40.4 dBm	1 MHz	This requirement does not apply to BS operating in Band n38.

System type for NR to co-exist with	Frequency range for co-existence requirement	Test limit	Measurement bandwidth	Notes
E-UTRA Band 70 or NR Band n70	1995 – 2020 MHz	-40.4 dBm	1 MHz	This requirement does not apply to BS operating in band n2, n25 or n70
	1695 – 1710 MHz	-37.4 dBm	1 MHz	This requirement does not apply to BS operating in band n70, since it is already covered by the requirement in clause 6.7.5.3.
E-UTRA Band 71 or NR Band n71	617 – 652 MHz	-40.4 dBm	1 MHz	This requirement does not apply to BS operating in band n71 or n105
	663 – 698 MHz	-37.4 dBm	1 MHz	This requirement does not apply to BS operating in band n71 or n105, since it is already covered by the requirement in clause 6.7.5.3.
E-UTRA Band 72 or NR Band n72	461 – 466 MHz	-40.4 dBm	1 MHz	This requirement does not apply to BS operating in band n31 or n72.
	451 – 456 MHz	-37.4 dBm	1 MHz	This requirement does not apply to BS operating in band n72, since it is already covered by the requirement in clause 6.7.5.3. This requirement does not apply to BS operating in band n31.
E-UTRA Band 74 or NR Band n74	1475 – 1518 MHz	-40.4 dBm	1 MHz	This requirement does not apply to BS operating in Band n50, n74, n75 or n109.
	1427 – 1470 MHz	-37.4 dBm	1MHz	This requirement does not apply to BS operating in Band n50, n51, n74, n75, n76 or n109.
E-UTRA Band 75 or NR Band n75	1432 – 1517 MHz	-40.4 dBm	1 MHz	This requirement does not apply to BS operating in Band n50, n51, n74, n75, n76 or n109.
E-UTRA Band 76 or NR Band n76	1427 – 1432 MHz	-40.4 dBm	1 MHz	This requirement does not apply to BS operating in Band n50, n51, n75, n76 or n109.
NR Band n77	3.3 – 4.2 GHz	-40 dBm	1 MHz	This requirement does not apply to BS operating in Band n77 or n78
NR Band n78	3.3 – 3.8 GHz	-40 dBm	1 MHz	This requirement does not apply to BS operating in Band n77 or n78
NR Band n79	4.4 – 5.0 GHz	-39.5 dBm	1 MHz	This requirement does not apply to BS operating in Band n79
NR Band n80	1710 – 1785 MHz	-37.4 dBm	1 MHz	This requirement does not apply to BS operating in band n3, since it is already covered by the requirement in clause 6.7.5.3.
NR Band n81	880 – 915 MHz	-37.4 dBm	1 MHz	This requirement does not apply to BS operating in band n8, since it is already covered by the requirement in clause 6.7.5.3.
NR Band n82	832 – 862 MHz	-37.4 dBm	1 MHz	This requirement does not apply to BS operating in band n20, since it is already covered by the requirement in clause 6.7.5.3.
NR Band n83	703 – 748 MHz	-37.4 dBm	1 MHz	This requirement does not apply to BS operating in band n28, since it is already covered by the requirement in clause 6.7.5.3.
NR Band n84	1920 – 1980 MHz	-37.4 dBm	1 MHz	This requirement does not apply to BS operating in band n1, since it is already covered by the requirement in clause 6.7.5.3.
E-UTRA Band 85 or NR Band n85	728 - 746 MHz	-40.4 dBm	1 MHz	This requirement does not apply to BS operating in band n12 or n85.
	698 - 716 MHz	-37.4 dBm	1 MHz	This requirement does not apply to BS operating in band n12 or n85, since it is already covered by the requirement in clause 6.7.5.3. For NR BS operating in n29, it applies 1 MHz below the Band n29 downlink operating band (Note 5).
NR Band n86	1710 – 1780 MHz	-37.4 dBm	1 MHz	This requirement does not apply to BS operating in band n66, since it is already covered by the requirement in clause 6.7.5.3.
NR Band n89	824 – 849 MHz	-37.4 dBm	1 MHz	This requirement does not apply to BS operating in band n5, since it is already covered by the requirement in clause 6.7.5.3.
NR Band n91	1427 – 1432 MHz	-40.4 dBm	1 MHz	This requirement does not apply to BS operating in Band n50, n51, n75, n76 or n109.

System type for NR to co-exist with	Frequency range for co-existence requirement	Test limit	Measurement bandwidth	Notes
	832 – 862 MHz	-37.4 dBm	1 MHz	This requirement does not apply to BS operating in band n20, since it is already covered by the requirement in clause 6.7.5.3.
NR Band n92	1432 – 1517 MHz	-40.4 dBm	1 MHz	This requirement does not apply to BS operating in Band n50, n51, n74, n75, n76 or n109.
	832 – 862 MHz	-37.4 dBm	1 MHz	This requirement does not apply to BS operating in band n20, since it is already covered by the requirement in clause 6.7.5.3.
NR Band n93	1427 – 1432 MHz	-40.4 dBm	1 MHz	This requirement does not apply to BS operating in Band n50, n51, n75, n76 or n109.
	880 – 915 MHz	-37.4 dBm	1 MHz	This requirement does not apply to BS operating in band n8, since it is already covered by the requirement in clause 6.7.5.3.
NR Band n94	1432 – 1517 MHz	-40.4 dBm	1 MHz	This requirement does not apply to BS operating in Band n50, n51, n74, n75, n76 or n109.
	880 – 915 MHz	-37.4 dBm	1 MHz	This requirement does not apply to BS operating in band n8, since it is already covered by the requirement in clause 6.7.5.3.
NR Band n95	2010 – 2025 MHz	-40.4 dBm	1 MHz	
NR Band n96	5925 – 7125 MHz	-39.5 dBm	1 MHz	This requirement does not apply to BS operating in Band n104.
NR Band n97	2300 – 2400MHz	-40.4 dBm	1 MHz	NR Band n97
NR Band n98	1880 – 1920MHz	-40.4 dBm	1 MHz	
NR Band n99	1626.5 – 1660.5 MHz	-37.4 dBm	1 MHz	This requirement does not apply to BS operating in band n24, since it is already covered by the requirement in clause 6.7.5.3.
NR Band n100	919.4 – 925 MHz	-40.4 dBm	1 MHz	This requirement does not apply to BS operating in Band n8.
	874.4 – 880 MHz	-37.4 dBm	1MHz	
NR Band n101	1900 - 1910 MHz	-40.4 dBm	1 MHz	
NR Band n102	6425 – 7125 MHz	-39.5 dBm	1 MHz	This requirement does not apply to BS operating in Band n104.
E-UTRA Band 103	757 – 758 MHz	-40.4 dBm	1 MHz	
	787 – 788 MHz	-37.4 dBm	1 MHz	
NR Band n104	6425 – 7125 MHz	-39.5 dBm	1 MHz	This requirement does not apply to BS operating in Band n104
NR Band n105	612 – 652 MHz	-40.4 dBm	1 MHz	This requirement does not apply to BS operating in band n71 or n105
	663 – 703 MHz	-37.4 dBm	1 MHz	This requirement does not apply to BS operating in band n105, since it is already covered by the requirement in clause 6.7.5.3.
E-UTRA Band 106 or NR Band n106	935 - 940 MHz	-40.4 dBm	1 MHz	This requirement does not apply to BS operating in Band n106
	896 – 901 MHz	-37.4 dBm	1 MHz	This requirement does not apply to BS operating in band n106, since it is already covered by the requirement in clause 6.7.5.3. This requirement does not apply to BS operating in Band n5 or n26.
NR Band n109	1432 – 1517 MHz	-40.4 dBm	1 MHz	This requirement does not apply to BS operating in Band n50, n51, n74, n75 or n76.
	703 – 733 MHz	-37.4 dBm	1 MHz1 MHz	This requirement does not apply to BS operating in band n28, since it is already covered by the requirement in clause 6.7.5.3.

NOTE 1: As defined in the scope for spurious emissions in this clause, except for the cases where the noted requirements apply to a BS operating in Band n28, the co-existence requirements in 6.7.5.4.5-1 do not apply for the  $\Delta f_{\text{OBUE}}$  frequency range immediately outside the downlink *operating band* (see TS 38.104 [2], table 5.2-1). Emission limits for this excluded frequency range may be covered by local or regional requirements.

NOTE 2: Table 6.7.5.4.5-1 assumes that two *operating bands*, where the frequency ranges in TS 38.104 [2] table 5.2-1 would be overlapping, are not deployed in the same geographical area. For such a case of operation with overlapping frequency arrangements in the same geographical area, special co-existence requirements may apply that are not covered by the 3GPP specifications.

NOTE 3: TDD base stations deployed in the same geographical area, that are synchronized and use the same or adjacent *operating bands* can transmit without additional co-existence requirements. For unsynchronized base stations, special co-existence requirements may apply that are not covered by the 3GPP specifications.

NOTE 4: For NR Band n28 BS, specific solutions may be required to fulfil the spurious emissions limits for BS for co-existence with E-UTRA Band 27 UL *operating band*.

NOTE 5: For NR Band n29 BS, specific solutions may be required to fulfil the spurious emissions limits for NR BS for co-existence with UTRA Band XII, E-UTRA Band 12 or NR Band n12 UL *operating band*, E-UTRA Band 17 UL *operating band* or E-UTRA Band 85 UL or NR Band n85 UL *operating band*.

The following requirement may be applied for the protection of PHS. This requirement is also applicable at specified frequencies falling between  $\Delta f_{\text{OBUE}}$  below the lowest BS transmitter frequency of the downlink *operating band* and  $\Delta f_{\text{OBUE}}$  above the highest BS transmitter frequency of the downlink *operating band*.  $\Delta f_{\text{OBUE}}$  is defined in clause 6.7.1.

The power of any spurious emission shall not exceed:

**Table 6.7.5.4.5-2: BS spurious emissions test limits for BS for co-existence with PHS**

Frequency range	Test limit	Measurement bandwidth	Note
1884.5 – 1915.7 MHz	-32 dBm	300 kHz	Applicable when co-existence with PHS system operating in 1884.5 - 1915.7 MHz

In certain regions, the following requirement may apply to BS operating in Band n50 and n75 within 1432-1452 MHz, and in Band n51 and Band n76. Emissions shall not exceed the test level specified in table 6.7.5.4.5-3. This requirement is also applicable at the frequency range from  $\Delta f_{\text{OBUE}}$  below the lowest frequency of the BS downlink *operating band* up to  $\Delta f_{\text{OBUE}}$  above the highest frequency of the BS downlink *operating band*.

**Table 6.7.5.4.5-3: Additional emission test limit for BS operating in Band n50 and n75 within 1432-1452 MHz, and in Band n51 and n76**

Filter centre frequency, $F_{\text{filter}}$	Test limit (dBm)	Measurement bandwidth
$F_{\text{filter}} = 1413.5 \text{ MHz}$	-42	27 MHz

In certain regions, the following requirement may apply to BS operating in NR Band n50 and n75 within 1492-1517 MHz, and in Band n74 within 1492-1518 MHz. The maximum level of emissions, measured as EIRP, on centre frequencies  $F_{\text{filter}}$  with filter bandwidth according to table 6.7.5.4.5-4, shall not exceed the EIRP limit.

**Table 6.7.5.4.5-4: Operating band n50, n74 and n75 emission test limits above 1518 MHz**

Filter centre frequency, $F_{\text{filter}}$	EIRP limit (dBm)	Measurement bandwidth
$1518.5 \text{ MHz} \leq F_{\text{filter}} \leq 1519.5 \text{ MHz}$	-0.8	1 MHz
$1520.5 \text{ MHz} \leq F_{\text{filter}} \leq 1558.5 \text{ MHz}$	-30	1 MHz

In certain regions, the following requirement shall be applied to BS operating in Band n14 to ensure that appropriate interference protection is provided to 700 MHz public safety operations. This requirement is also applicable at the

frequency range from 10 MHz below the lowest frequency of the BS downlink operating band up to 10 MHz above the highest frequency of the BS downlink operating band.

The power of any spurious emission shall not exceed:

**Table 6.7.5.4.5-5: BS Spurious emissions limits for protection of 700 MHz public safety operations**

Operating Band	Frequency range	Maximum Level	Measurement Bandwidth
n13	763 - 775 MHz	-37 dBm	6.25 kHz
n13	793 - 805 MHz	-37 dBm	6.25 kHz
n14	769 – 775 MHz	-37 dBm	6.25 kHz
n14	799 – 805 MHz	-37 dBm	6.25 kHz

The following requirement may apply to NR BS operating in Band n30 in certain regions. This requirement is also applicable at the frequency range from 10 MHz below the lowest frequency of the BS downlink operating band up to 10 MHz above the highest frequency of the BS downlink operating band.

The power of any spurious emission shall not exceed:

**Table 6.7.5.4.5-6: Additional NR BS Spurious emissions limits for Band n30**

Frequency range	Basic limit	Measurement bandwidth
2200 – 2345 MHz	-33.4 dBm	1 MHz
2362.5 – 2365 MHz	-13.4 dBm	
2365 – 2367.5 MHz	-28.4 dBm	
2367.5 – 2370 MHz	-30.4 dBm	
2370 – 2395 MHz	-33.4 dBm	

NOTE: The regional requirement, included in ECC/DEC/(17)06 [15], is defined in terms of EIRP, which is dependent on both the BS emissions at the antenna connector and the deployment (including antenna gain and feeder loss). The requirement defined above provides the characteristics of the base station needed to verify compliance with the regional requirement. The assessment of the EIRP level is described in TS 38.104 [2] annex E.

The following requirement shall be applied to BS operating in Band n26 to ensure that appropriate interference protection is provided to 800 MHz public safety operations. This requirement is also applicable at the frequency range from 10 MHz below the lowest frequency of the BS downlink operating band up to 10 MHz above the highest frequency of the BS downlink operating band.

The TRP of any spurious emission shall not exceed:

**Table 6.7.5.4.5-7: BS OTA Spurious emissions limits for protection of 800 MHz public safety operations**

Operating Band	Frequency range	Maximum Level	Measurement Bandwidth	Note
n26	851 - 859 MHz	-4 dBm	100 kHz	Applicable for offsets > 37.5kHz from the channel edge

The following requirement may apply to BS for Band n41 and n90 operation in Japan. This requirement is also applicable at the frequency range from  $\Delta f_{\text{OBUE}}$  below the lowest frequency of the BS downlink operating band up to  $\Delta f_{\text{OBUE}}$  above the highest frequency of the BS downlink operating band.

The power of any spurious emission shall not exceed:

**Table 6.7.5.4.5-8: Additional BS Spurious emissions limits for Band n41 and n90**

Frequency range	Test limit	Measurement Bandwidth
2505 MHz – 2535 MHz	-33 dBm	1 MHz
NOTE: This requirement applies for carriers allocated within 2545-2645 MHz.		

The following requirement may also apply to BS operating in Band n54 in certain regions. The level of emissions in the 1541 – 1650 MHz band, measured in measurement bandwidth according to Table 6.7.5.4.5-9 shall not exceed the maximum TRP limits indicated in the table.

**Table 6.7.5.4.5-9: Declared Band n54 emissions levels for protection of the 1541-1650 MHz band**

Operating Band	Frequency range	Declared emission level (dBW) (Measurement bandwidth = 1 MHz)	Declared emission level (dBW) of discrete emissions of less than 700 Hz bandwidth (Measurement bandwidth = 1 kHz)	Declared emission level (dBW) of discrete emissions of less than 2 kHz bandwidth (Measurement bandwidth = 1 kHz)
n54	1541 - 1559 MHz	$P_{\text{EIRP}} - 17 \text{ dBi} + 9 \text{ dB}$		$P_{\text{EIRP}} - 17 \text{ dBi} + 9 \text{ dB}$
	1559 - 1610 MHz	$P_{\text{EIRP}} - 17 \text{ dBi} + 9 \text{ dB}$	$P_{\text{EIRP}} - 17 \text{ dBi} + 9 \text{ dB}$	
	1610 - 1650 MHz	$P_{\text{EIRP}} - 17 \text{ dBi} + 9 \text{ dB}$	$P_{\text{EIRP}} - 17 \text{ dBi} + 9 \text{ dB}$	

Note: The regional requirements in attachment to the FCC reference document, 0007135419, are defined in terms of EIRP (effective isotropic radiated power), which is dependent on both the BS emissions at the antenna connector and the deployment (including antenna gain and feeder loss).

#### 6.7.5.4.5.2 Test requirement for BS type 2-0

For BS operating in the frequency range 24.25 – 27.5 GHz, the power of any spurious emissions shall not exceed the limits in Table 6.7.5.4.5.2-1.

**Table 6.7.5.4.5.2-1: BS spurious emissions test limits for protection of Earth Exploration Satellite Service**

Frequency range	Limit	Measurement Bandwidth	Note
23.6 – 24 GHz	-3 dBm	200 MHz	Note 1
23.6 – 24 GHz	-9 dBm	200 MHz	Note 2
NOTE 1: This limit applies to BS brought into use on or before 1 September 2027.			
NOTE 2: This limit applies to BS brought into use after 1 September 2027.			

### 6.7.5.5 Co-location requirements

#### 6.7.5.5.1 Definition and applicability

These requirements may be applied for the protection of other BS receivers when GSM900, DCS1800, PCS1900, GSM850, CDMA850, UTRA FDD, UTRA TDD, E-UTRA and/or NR BS are co-located with a BS.

The requirements assume co-location with base stations of the same class.

NOTE: For co-location with UTRA, the requirements are based on co-location with UTRA FDD or TDD base stations.

This requirement is a co-location requirement as defined in clause 4.9, in TS 38.104 [2], the power levels are specified at the CLTA output.

### 6.7.5.5.2 Minimum requirements

The minimum requirement for *BS type I-O* is defined in TS 38.104 [2], clause 9.7.5.2.

### 6.7.5.5.3 Test purpose

For OTA co-locate spurious emission, the test purpose is to verify that the emission is within the specified requirement limits at the CLTA conducted output(s).

### 6.7.5.5.4 Method of test

#### 6.7.5.5.4.1 Initial conditions

Test environment: normal; see clause B.2.

RF channels to be tested for single carrier: M; see clause 4.9.1.

*Base Station RF Bandwidth* positions to be tested for multi-carrier:

- $M_{\text{RFBW}}$  in *single-band RIB*, see clause 4.9.1;
- $B'_{\text{RFBW}}T'_{\text{RFBW}}$  and  $B'_{\text{RFBW}}T_{\text{RFBW}}$  in *multi-band RIB*, see clause 4.9.1.

In addition, for *multi-band RIB*:

- For  $B'_{\text{RFBW}}T'_{\text{RFBW}}$ , emission testing above the highest operating band may be omitted.
- For  $B'_{\text{RFBW}}T_{\text{RFBW}}$ , emission testing below the lowest operating band may be omitted.

Directions to be tested: The FR1 requirement is specified as co-location requirement. For general description of co-location requirements, refer to clause 4.12.

The co-location spurious emission is measured at the CLTA conducted output(s).

#### 6.7.5.5.4.2 Procedure

- 1) Select and place the NR BS and CLTA as described in clause 4.12, with parameters as specified in table 4.12.2.2-1 and table 4.12.2.3-1.
- 2) Several CLTAs might be required to cover the whole co-location spurious emission frequency ranges.
- 3) Place test antenna in reference direction at far-field distance, aligned in all supported polarizations (single or dual) with the NR BS as depicted in annex E.1.3.
- 4) The test antenna shall be dual (or single) polarized with the same frequency range as the NR BS for co-location spurious emission test case.
- 5) Connect test antenna and CLTA to the measurement equipment as depicted in annex E.1.3.
- 6) OTA co-location spurious emission is measured as the power sum over all supported polarizations at the CLTA conducted output(s).
- 7) The measurement device (signal analyzer) characteristics shall be:
  - Detection mode: True RMS.

The emission power should be averaged over an appropriate time duration to ensure the measurement is within the measurement uncertainty in Table 4.1.2.2-1.

- 8) Set the *BS type I-O* to transmit:
  - Set the NR BS to transmit maximum power according to the applicable test configuration in clause 4.8 using the corresponding test models or set of physical channels in clause 4.9.2.



- For the NR BS declared to be capable of multi-carrier and/or CA operation, set the BS to transmit according to the applicable test configuration and corresponding power setting specified in clause 4.7.2 and 4.8 using the corresponding test models on all carriers configured.

9) Measure the emission at the specified frequencies with specified measurement bandwidth.

In addition, for *multi-band RIB*, the following steps shall apply:

- 10) For *multi-band RIB* and single band tests, repeat the steps above per involved band where single band test configurations and test models shall apply with no carrier activated in the other band.

#### 6.7.5.5.5 Test requirements

##### 6.7.5.5.5.1 Test requirement for *BS type 1-O*

These requirements may be applied for the protection of other BS receivers when GSM900, DCS1800, PCS1900, GSM850, CDMA850, UTRA FDD, UTRA TDD, E-UTRA and/or NR BS are co-located with a BS.

The requirements assume co-location with base stations of the same class.

NOTE: For co-location with UTRA, the requirements are based on co-location with UTRA FDD or TDD base stations.

This requirement is a co-location requirement as defined in clause 4.9, in TS 38.104 [2], the power levels are specified at the CLTA output.

The output of the CLTA of any spurious emission shall not exceed the test limit in table 6.7.5.5.1-1.

For a *multi-band RIB*, the exclusions and conditions in the notes column of table 6.7.5.5.1-1 apply for each supported operating band.

**Table 6.7.5.5.1-1: *BS type 1-O* OTA spurious emissions limits for BS co-located with another BS**

Type of co-located BS	Frequency range for co-location requirement	Test limit			Measurement bandwidth	Note
		WA BS	MR BS	LA BS		
GSM900	876-915 MHz	-115.9 dBm	-108.9 dBm	-87.9 dBm	100 kHz	
DCS1800	1710 – 1785 MHz	-115.9 dBm	-108.9 dBm	-97.9 dBm	100 kHz	
PCS1900	1850 – 1910 MHz	-115.9 dBm	-108.9 dBm	-97.9 dBm	100 kHz	
GSM850 or CDMA850	824 – 849 MHz	-115.9 dBm	-108.9 dBm	-87.9 dBm	100 kHz	
UTRA FDD Band I or E-UTRA Band 1 or NR Band n1	1920 – 1980 MHz	-113.9 dBm	-108.9 dBm	-105.9 dBm	100 kHz	
UTRA FDD Band II or E-UTRA Band 2 or NR Band n2	1850 – 1910 MHz	-113.9 dBm	-108.9 dBm	-105.9 dBm	100 kHz	
UTRA FDD Band III or E-UTRA Band 3 or NR Band n3	1710 – 1785 MHz	-113.9 dBm	-108.9 dBm	-105.9 dBm	100 kHz	
UTRA FDD Band IV or E-UTRA Band 4	1710 – 1755 MHz	-113.9 dBm	-108.9 dBm	-105.9 dBm	100 kHz	
UTRA FDD Band V or E-UTRA Band 5 or NR Band n5	824 – 849 MHz	-113.9 dBm	-108.9 dBm	-105.9 dBm	100 kHz	
UTRA FDD Band VI, XIX or E-UTRA Band 6, 19	830 – 845 MHz	-113.9 dBm	-108.9 dBm	-105.9 dBm	100 kHz	
UTRA FDD Band VII or E-UTRA Band 7 or NR Band n7	2500 – 2570 MHz	-113.9 dBm	-108.9 dBm	-105.9 dBm	100 kHz	
UTRA FDD Band VIII or E-UTRA Band 8 or NR Band n8	880 – 915 MHz	-113.9 dBm	-108.9 dBm	-105.9 dBm	100 kHz	
UTRA FDD Band IX or E-UTRA Band 9	1749.9 – 1784.9 MHz	-113.9 dBm	-108.9 dBm	-105.9 dBm	100 kHz	
UTRA FDD Band X or E-UTRA Band 10	1710 – 1770 MHz	-113.9 dBm	-108.9 dBm	-105.9 dBm	100 kHz	
UTRA FDD Band XI or E-UTRA Band 11	1427.9 – 1447.9 MHz	-113.9 dBm	-108.9 dBm	-105.9 dBm	100 kHz	This is not applicable to BS operating in Band n50 , n75 or n109
UTRA FDD Band XII or E-UTRA Band 12	699 – 716 MHz	-113.9 dBm	-108.9 dBm	-105.9 dBm	100 kHz	
UTRA FDD Band XIII or E-UTRA Band 13 or NR Band n13	777 – 787 MHz	-113.9 dBm	-108.9 dBm	-105.9 dBm	100 kHz	
UTRA FDD Band XIV or E-UTRA Band 14 or NR Band n14	788 – 798 MHz	-113.9 dBm	-108.9 dBm	-105.9 dBm	100 kHz	
E-UTRA Band 17	704 – 716 MHz	-113.9 dBm	-108.9 dBm	-105.9 dBm	100 kHz	
E-UTRA Band 18	815 – 830 MHz	-113.9 dBm	-108.9 dBm	-105.9 dBm	100 kHz	
UTRA FDD Band XX or E-UTRA Band 20 or NR Band n20	832 – 862 MHz	-113.9 dBm	-108.9 dBm	-105.9 dBm	100 kHz	
UTRA FDD Band XXI or E-UTRA Band 21	1447.9 – 1462.9 MHz	-113.9 dBm	-108.9 dBm	-105.9 dBm	100 kHz	This is not applicable to BS operating in Band n50, n75 or n109
UTRA FDD Band XXII or E-UTRA Band 22	3410 – 3490 MHz	-113.7 dBm	-108.7 dBm	-105.7 dBm	100 kHz	This is not applicable to BS operating in Band n77 or n78

E-UTRA Band 24 or NR Band n24	1626.5 – 1660.5 MHz	-113.9 dBm	-108.9 dBm	-105.9 dBm	100 kHz	
UTRA FDD Band XXV or E-UTRA Band 25	1850 – 1915 MHz	-113.9 dBm	-108.9 dBm	-105.9 dBm	100 kHz	
UTRA FDD Band XXVI or E-UTRA Band 26 or NR Band n26	814 – 849 MHz	-113.9 dBm	-108.9 dBm	-105.9 dBm	100 kHz	
E-UTRA Band 27	807 – 824 MHz	-113.9 dBm	-108.9 dBm	-105.9 dBm	100 kHz	
E-UTRA Band 28 or NR Band n28	703 – 748 MHz	-113.9 dBm	-108.9 dBm	-105.9 dBm	100 kHz	
E-UTRA Band 30 or NR Band n30	2305 – 2315 MHz	-113.9 dBm	-108.9 dBm	-105.9 dBm	100 kHz	
E-UTRA Band 31 or NR Band n31	452.5 -457.5 MHz	-113.9 dBm	-108.9 dBm	-105.9 dBm	100 kHz	
UTRA TDD Band a) or E-UTRA Band 33	1900 – 1920 MHz	-113.9 dBm	-108.9 dBm	-105.9 dBm	100 kHz	
UTRA TDD Band a) or E-UTRA Band 34	2010 – 2025 MHz	-113.9 dBm	-108.9 dBm	-105.9 dBm	100 kHz	
UTRA TDD Band b) or E-UTRA Band 35	1850 – 1910 MHz	-113.9 dBm	-108.9 dBm	-105.9 dBm	100 kHz	
UTRA TDD Band b) or E-UTRA Band 36	1930 – 1990 MHz	-113.9 dBm	-108.9 dBm	-105.9 dBm	100 kHz	This is not applicable to BS operating in Band n2
UTRA TDD Band c) or E-UTRA Band 37	1910 – 1930 MHz	-113.9 dBm	-108.9 dBm	-105.9 dBm	100 kHz	
UTRA TDD Band d) or E-UTRA Band 38 or NR Band n38	2570 – 2620 MHz	-113.9 dBm	-108.9 dBm	-105.9 dBm	100 kHz	This is not applicable to BS operating in Band n38.
UTRA TDD Band f) or E-UTRA Band 39	1880 – 1920 MHz	-113.9 dBm	-108.9 dBm	-105.9 dBm	100 kHz	
UTRA TDD Band e) or E-UTRA Band 40	2300 – 2400MHz	-113.9 dBm	-108.9 dBm	-105.9 dBm	100 kHz	
E-UTRA Band 41 or NR Band n41	2496 – 2690 MHz	-113.9 dBm	-108.9 dBm	-105.9 dBm	100 kHz	This is not applicable to BS operating in Band n41
E-UTRA Band 42	3400 – 3600 MHz	-113.7 dBm	-108.7 dBm	-105.7 dBm	100 kHz	This is not applicable to BS operating in Band n77 or n78
E-UTRA Band 43	3600 – 3800 MHz	-113.7 dBm	-108.7 dBm	-105.7 dBm	100 kHz	This is not applicable to BS operating in Band n77 or n78
E-UTRA Band 44	703 – 803 MHz	-113.9 dBm	-108.9 dBm	-105.9 dBm	100 kHz	This is not applicable to BS operating in Band n28
E-UTRA Band 45	1447 – 1467 MHz	-113.9 dBm	-108.9 dBm	-105.9 dBm	100 kHz	
E-UTRA Band 46 or NR Band n46	5150 – 5925 MHz	N/A	-108.6 dBm	-105.6 dBm	100 kHz	
E-UTRA Band 48	3550 – 3700 MHz	-113.7 dBm	-108.7 dBm	-105.7 dBm	100 kHz	This is not applicable to BS operating in Band n77 or n78
E-UTRA Band 50 or NR Band n50	1432 – 1517 MHz	-113.9 dBm	-108.9 dBm	-105.9 dBm	100 kHz	This is not applicable to BS operating in Band n74, n75 or n109

E-UTRA Band 51 or NR Band n51	1427 – 1432 MHz	N/A	N/A	-105.9 dBm	100 kHz	This is not applicable to BS operating in Band n50, n75, n76 or n109
E-UTRA Band 53 or NR Band n53	2483.5 – 2495 MHz	N/A	-108.9 dBm	-105.9 dBm	100 kHz	This is not applicable to BS operating in Band n41 or n90
E-UTRA Band 54 or NR Band n54	1670 – 1675 MHz	-113.9 dBm	-108.9 dBm	-105.9 dBm	100 kHz	This is not applicable to BS operating in Band n54
E-UTRA Band 65 or NR Band n65	1920 – 2010 MHz	-113.9 dBm	-108.9 dBm	-105.9 dBm	100 kHz	
E-UTRA Band 66 or NR Band n66	1710 – 1780 MHz	-113.9 dBm	-108.9 dBm	-105.9 dBm	100 kHz	
E-UTRA Band 68	698 – 728 MHz	-113.9 dBm	-108.9 dBm	-105.9 dBm	100 kHz	
E-UTRA Band 70 or NR Band n70	1695 – 1710 MHz	-113.9 dBm	-108.9 dBm	-105.9 dBm	100 kHz	
E-UTRA Band 71 or NR Band n71	663 – 698 MHz	-113.9 dBm	-108.9 dBm	-105.9 dBm	100 kHz	
E-UTRA Band 72 or NR Band n72	451 – 456 MHz	-113.9 dBm	-108.9 dBm	-105.9 dBm	100 kHz	
E-UTRA Band 74 or NR Band n74	1427 – 1470 MHz	-113.9 dBm	-108.9 dBm	-105.9 dBm	100 kHz	This is not applicable to BS operating in Band n50
NR Band n77	3.3 – 4.2 GHz	-113.7 dBm	-108.7 dBm	-105.7 dBm	100 kHz	This is not applicable to BS operating in Band n77 or n78
NR Band n78	3.3 – 3.8 GHz	-113.7 dBm	-108.7 dBm	-105.7 dBm	100 kHz	This is not applicable to BS operating in Band n77 or n78
NR Band n79	4.4 – 5.0 GHz	-113.6 dBm	-108.6 dBm	-105.6 dBm	100 kHz	
NR Band n80	1710 – 1785 MHz	-113.9 dBm	-108.9 dBm	-105.9 dBm	100 kHz	
NR Band n81	880 – 915 MHz	-113.9 dBm	-108.9 dBm	-105.9 dBm	100 kHz	
NR Band n82	832 – 862 MHz	-113.9 dBm	-108.9 dBm	-105.9 dBm	100 kHz	
NR Band n83	703 – 748 MHz	-113.9 dBm	-108.9 dBm	-105.9 dBm	100 kHz	
NR Band n84	1920 – 1980 MHz	-113.9 dBm	-108.9 dBm	-105.9 dBm	100 kHz	
E-UTRA Band 85 or NR Band n85	698 - 716 MHz	-113.9 dBm	-108.9 dBm	-105.9 dBm	100 kHz	
NR Band n86	1710 – 1780 MHz	-113.9 dBm	-108.9 dBm	-105.9 dBm	100 kHz	
NR Band n89	824 – 849 MHz	-113.9 dBm	-108.9 dBm	-105.9 dBm	100 kHz	
NR Band n95	2010 – 2025 MHz	-113.9 dBm	-108.9 dBm	-105.9 dBm	100 kHz	
NR Band 96	5925 - 7125	N/A	-107.6 dBm	-104.6 dBm	100 kHz	
NR Band n97	2300 – 2400MHz	-113.9 dBm	-108.9 dBm	-105.9 dBm	100 kHz	
NR Band n98	1880 – 1920 MHz	-113.9 dBm	-108.9 dBm	-105.9 dBm	100 kHz	
NR Band n99	1626.5 – 1660.5 MHz	-113.9 dBm	-108.9 dBm	-105.9 dBm	100 kHz	
NR band n100	874.4 – 880 MHz	-113.9 dBm	NA	NA	100 kHz	

NR band n101	1900 - 1910 MHz	-113.9 dBm	NA	NA	100 kHz	
NR Band n102	6425 – 7125 MHz	N/A	-107.6 dBm	-104.6 dBm	100 kHz	
E-UTRA Band 103	787 – 788 MHz	-113.9 dBm	-108.9 dBm	-105.9 dBm	100 kHz	
NR Band n104	6425 – 7125 MHz	-112.6 dBm	-107.6 dBm	-104.6 dBm	100 kHz	This is not applicable to BS operating in Band n104
NR Band n105	663 – 703 MHz	-113.9 dBm	-108.9 dBm	-105.9 dBm	100 kHz	
E-UTRA Band 106 or NR Band n106	896 – 901 MHz	-113.9 dBm	-108.9 dBm	-105.9 dBm	100 kHz	
NR Band n109	703 – 733 MHz	-113.9 dBm	-108.9 dBm	-105.9 dBm	100 kHz/100 kHz	

NOTE 1: As defined in the scope for spurious emissions in this clause, the co-location requirements in table 6.7.5.5.1-1 do not apply for the frequency range extending  $\Delta f_{\text{OBUE}}$  immediately outside the BS transmit frequency range of a downlink *operating band* (see table 5.2-1 in TS 38.104 [2]). The current state-of-the-art technology does not allow a single generic solution for co-location with other system on adjacent frequencies for 30 dB BS-BS minimum coupling loss. However, there are certain site-engineering solutions that can be used. These techniques are addressed in TR 25.942 [27].

NOTE 2: Table 6.7.5.5.1-1 assumes that two *operating bands*, where the corresponding BS transmit and receive frequency ranges in table 5.2-1 in TS 38.104 [2] would be overlapping, are not deployed in the same geographical area. For such a case of operation with overlapping frequency arrangements in the same geographical area, special co-location requirements may apply that are not covered by the 3GPP specifications.

NOTE 3: Co-located TDD base stations that are synchronized and using the same or adjacent *operating band* can transmit without special co-locations requirements. For unsynchronized base stations, special co-location requirements may apply that are not covered by the 3GPP specifications.

## 6.8 OTA transmitter intermodulation

### 6.8.1 Definition and applicability

The OTA transmitter intermodulation requirement is a measure of the capability of the transmitter unit to inhibit the generation of signals in its non-linear elements caused by presence of the wanted signal and an interfering signal reaching the transmitter unit via the RDN and antenna array from a co-located base station. The requirement applies during the *transmitter ON period* and the *transmitter transient period*.

The requirement applies at each RIB supporting transmission in the operating band.

The transmitter intermodulation level is the total radiated power of the intermodulation products when an interfering signal is injected into the CLTA.

For *BS type 1-O*, the transmitter intermodulation requirement is captured by the co-location transmitter intermodulation scenario case, in which the interfering signal is injected into the CLTA.

### 6.8.2 Minimum requirement

The minimum requirement for *BS type 1-O* operation is defined in TS 38.104 [2], clause 9.8.2.

The OTA transmitter intermodulation requirement is not applicable for *BS type 2-O*.

### 6.8.3 Test purpose

The test purpose is to verify the ability of the transmitter units associated with the *RIB* under test to restrict the generation of intermodulation products in its nonlinear elements caused by presence of the wanted signal and an

interfering signal reaching the transmitter unit via the RDN and antenna array from a co-located base station to below specified levels.

## 6.8.4 Method of test

### 6.8.4.1 Initial conditions

Test environment: normal; see annex B.2.

RF channels to be tested for single carrier:  $M$ ; see clause 4.9.1.

*Base Station RF Bandwidth* positions to be tested for multi-carrier:

- $M_{\text{RFBW}}$  in *single-band RIB*, see clause 4.9.1;
- $B'_{\text{RFBW}}T'_{\text{RFBW}}$  and  $B'_{\text{RFBW}}T_{\text{RFBW}}$  in *multi-band RIB*, see clause 4.9.1.

In addition, for *multi-band RIB*:

- For  $B'_{\text{RFBW}}T'_{\text{RFBW}}$ , emission testing above the highest operating band may be omitted.
- For  $B'_{\text{RFBW}}T_{\text{RFBW}}$ , emission testing below the lowest operating band may be omitted.

Directions to be tested: The FR1 requirement is specified as co-location requirement. For general description of co-location requirements, refer to clause 4.12.

### 6.8.4.2 Procedure

- 1) Select a CLTA according to the description in clause 4.12 and parameters given in table 4.12.2.2-1.
- 2) Place the CLTA according to the description in clause 4.12 and parameters given in table 4.12.2.3-1.
- 3) The test antenna(s) shall be dual (or single) polarized covering the same frequency range as the NR BS and the emission frequencies.
- 4) Several test antennas are required to cover both the NR BS and the whole emission frequency range.
- 5) Connect test antenna and CLTA to the measurement equipment as shown in annex E.1.5.
- 6) During the OTA emission measurements at the test antenna conducted output(s), both NR BS and CLTA are rotated around same axis.
- 7) The OTA emission measurement method shall be TRP, according to the procedure described in annex I.
- 8) The measurement device (signal analyzer) characteristics shall be:
  - Detection mode: True RMS.

The emission power should be averaged over an appropriate time duration to ensure the measurement is within the measurement uncertainty in Table 4.1.2.2-1.

- 9) Set the BS *type I-O* to transmit:
  - Set the NR BS to transmit maximum power according to the applicable test configuration in clause 4.8 using the corresponding test models or set of physical channels in clause 4.9.2.
  - For the NR BS declared to be capable of multi-carrier and/or CA operation, set the BS to transmit according to the applicable test configuration and corresponding power setting specified in clause 4.7.2 and 4.8 using the corresponding test models on all carriers configured.
- 10) Generate the interfering signal using test model as defined in clause 4.9.2, at a centre frequency offset according to the conditions in table 9.8.2-1 in TS 38.104 [2], but exclude interfering frequencies that are outside of the allocated downlink operating band or interfering frequencies that are not completely within the sub-block gap or within the *Inter RF Bandwidth gap*.

- 11) Connect the interfering signal to the CLTA input interfaces, equally dividing the power among supported polarizations. Adjust the interfering signal level at the CLTA conducted input(s) as defined in table 6.8.5.1-1.
- 12) If the interfering signal is applicable according to clause 4.7, perform the unwanted emission tests specified in clauses 6.7.3 (OTA ACLR) and 6.7.4 (OTA OBUE) for all third and fifth order intermodulation products which appear in the frequency ranges defined in clauses 6.7.3 and 6.7.4 (Note 2). The width of the intermodulation products shall be taken into account.
- 13) If the interfering signal is applicable according to clause 4.7, perform the Transmitter spurious emissions test as specified in clause 6.7.5 (OTA spurious emission), except OTA co-location spurious emission, for all third and fifth order intermodulation products which appear in the frequency ranges defined in clause 6.7.5 (Note 2). The width of the intermodulation products shall be taken into account.
- 14) Verify that the emission level does not exceed the required level in clause 6.8.5 (Test requirements) with the exception of interfering signal frequencies.
- 15) Repeat the test for the remaining interfering signal centre frequency offsets defined in table 6.8.5.1-1.
- 16) Repeat the test for the remaining interfering signals defined in clause 4.7 for requirements 6.7.3 (OTA ACLR), 6.7.4 (OTA OBUE) and 6.7.5 (OTA spurious emission), except OTA co-location spurious emission.

In addition, for *multi-band RIB*, the following steps shall apply:

- 17) For *multi-band RIB* and single band tests, repeat the steps above per involved band where single band test configurations and test models shall apply with no carrier activated in the other band.

NOTE 1: The third order intermodulation products are centred at  $2F1 \pm F2$  and  $2F2 \pm F1$ . The fifth order intermodulation products are centred at  $3F1 \pm 2F2$ ,  $3F2 \pm 2F1$ ,  $4F1 \pm F2$ , and  $4F2 \pm F1$  where  $F1$  represents the test signal centre frequency or centre frequency of each sub-block and  $F2$  represents the interfering signal centre frequency. The widths of intermodulation products are:

- $(n \cdot BW_{F1} + m \cdot BW_{F2})$  for the  $nF1 \pm mF2$  products;
- $(n \cdot BW_{F2} + m \cdot BW_{F1})$  for the  $nF2 \pm mF1$  products;

where  $BW_{F1}$  represents the test wanted signal RF bandwidth or channel bandwidth in case of single carrier, or sub-block bandwidth and  $BW_{F2}$  represents the interfering signal channel bandwidth.

NOTE 2: During the conformance test the interferer signal can be applied on one side of the wanted signal, while the transmitter intermodulation emission is measured only on the opposite side of the wanted signal. This applies for intermodulation products which are within the operating band or OBUE region.

## 6.8.5 Test requirements

### 6.8.5.1 Requirement for BS type 1-O

The transmitter intermodulation level shall not exceed the TRP unwanted emission limits specified for OTA transmitter spurious emission in clause 6.7.5 (except co-location with other base stations), OTA out-of-band emissions in clause 6.7.4 and OTA ACLR in clause 6.7.3 in the presence of a wanted signal and an interfering signal, defined in table 6.8.5.1-1.

The requirement is applicable outside the *Base Station RF Bandwidth edges*. The interfering signal offset is defined relative to the *Base Station RF Bandwidth edges* or *Radio Bandwidth edges*.

For RIBs supporting operation in *non-contiguous spectrum*, the requirement is also applicable inside a *sub-block gap* for interfering signal offsets where the interfering signal falls completely within the *sub-block gap*. The interfering signal offset is defined relative to the *sub-block edges*.

For RIBs supporting operation in multiple *operating bands*, the requirement shall apply relative to the *Base Station RF Bandwidth edges* of each *operating band*. In case the inter *RF Bandwidth gap* is less than  $3 \cdot BW_{\text{Channel}}$  MHz (where  $BW_{\text{Channel}}$  is the minimal *BS channel bandwidth* of the band), the requirement in the gap shall apply only for interfering signal offsets where the interfering signal falls completely within the inter *RF Bandwidth gap*.



**Table 6.8.5.1-1: Interfering and wanted signals for the OTA transmitter intermodulation requirement**

Parameter	Value
Wanted signal	NR single or multi-carrier, or multiple intra-band contiguously or non-contiguously aggregated carriers
Interfering signal type	NR signal, the minimum <i>BS channel bandwidth</i> ( $BW_{\text{channel}}$ ) with 15 kHz SCS of the band defined in clause 5.3.5 of TS 38.104 [2]
Interfering signal power level	$\min(46 \text{ dBm}, P_{\text{rated,t,TRP}})$
Interfering signal centre frequency offset from the lower (upper) edge of the wanted signal or edge of <i>sub-block</i> inside a gap	$f_{\text{offset}} = \pm BW_{\text{channel}} \left( n - \frac{1}{2} \right)$ , for $n=1, 2$ and $3$
NOTE 1: Interfering signal positions that are partially or completely outside of any downlink <i>operating band</i> of the BS are excluded from the requirement, unless the interfering signal positions fall within the frequency range of adjacent downlink <i>operating bands</i> in the same geographical area.	
NOTE 2: In Japan, note 1 is not applied in Band n77, n78, n79.	
NOTE 3: For <i>BS type 1-0</i> supporting dual polarization, the interfering signal power shall be equally divided between supported polarizations at the CLTA interfaces.	

### 6.8.5.2 Additional requirements (regional)

For Band n26 and n28 operation in Japan, when the narrowest channel bandwidth supported by the BS is 5 MHz or wider, the transmitter intermodulation level shall not exceed the TRP unwanted emission limits specified for OTA transmitter spurious emission in clause 6.7.5 (except co-location with other base stations), OTA out-of-band emissions in clause 6.7.4 and OTA ACLR in clause 6.7.3 in the presence of a wanted signal and an interfering signal, defined in table 6.8.5.2-1.

**Table 6.8.5.2-1: Interfering and wanted signals for the OTA transmitter intermodulation requirement for n26 and n28 when the narrowest channel bandwidth supported by the BS is 5MHz or wider**

Parameter	Value
Wanted signal	NR single carrier
Interfering signal type	NR signal of 5 MHz <i>channel bandwidth</i>
Interfering signal power level	$\min(46 \text{ dBm}, P_{\text{rated,t,TRP}})$
Interfering signal centre frequency offset from the lower (upper) edge of the wanted signal	$\pm 2.5 \text{ MHz}$ $\pm 7.5 \text{ MHz}$ $\pm 12.5 \text{ MHz}$

For Band n79 operation in Japan, the transmitter intermodulation level shall not exceed the TRP unwanted emission limits specified for OTA transmitter spurious emission in clause 6.7.5 (except co-location with other base stations), OTA out-of-band emissions in clause 6.7.4 and OTA ACLR in clause 6.7.3 in the presence of a wanted signal and an interfering signal, defined in table 6.8.5.2-2.

**Table 6.8.5.2-2: Interfering and wanted signals for the OTA transmitter intermodulation requirement for n79**

Parameter	Value
Wanted signal	NR single carrier
Interfering signal type	NR signal of 40 MHz <i>channel bandwidth</i>
Interfering signal power level	$\min(46 \text{ dBm}, P_{\text{rated,t,TRP}})$
Interfering signal centre frequency offset from the lower (upper) edge of the wanted signal	$\pm 20 \text{ MHz}$ $\pm 60 \text{ MHz}$ $\pm 100 \text{ MHz}$

## 7 Radiated receiver characteristics

### 7.1 General

General test conditions for receiver tests are given in clause 4, including interpretation of measurement results and configurations for testing. BS configurations for the tests are defined in clause 4.5.

Unless otherwise stated, the following arrangements apply for radiated receiver characteristics requirements in clause 7:

- Requirements apply during the BS receive period.
- Requirements shall be met for any transmitter setting.
- For FDD operation the requirements shall be met with the transmitter unit(s) ON.
- Throughput requirements defined for the radiated receiver characteristics do not assume HARQ retransmissions.
- When BS is configured to receive multiple carriers, all the throughput requirements are applicable for each received carrier.
- For ACS, blocking and intermodulation characteristics, the negative offsets of the interfering signal apply relative to the lower *Base Station RF Bandwidth* edge or *sub-block* edge inside a *sub-block gap*, and the positive offsets of the interfering signal apply relative to the upper *Base Station RF Bandwidth* edge or *sub-block* edge inside a *sub-block gap*.

NOTE 1: In normal operating condition the BS in FDD operation is configured to transmit and receive at the same time.

NOTE 2: In normal operating condition the BS in TDD operation is configured to TX OFF power during *receive period*.

Each requirement, except OTA receiver spurious emissions, shall be met over the RoAoA specified.

For FR1 requirements which are to be met over the *OTA REFSENS RoAoA* absolute requirement values are offset by the following term:

$$\Delta_{\text{OTAREFSENS}} = 44.1 - 10 \cdot \log_{10}(\text{BeW}_{\theta, \text{REFSENS}} \cdot \text{BeW}_{\phi, \text{REFSENS}}) \text{ (dB) for the reference direction.}$$

And

$$\Delta_{\text{OTAREFSENS}} = 41.1 - 10 \cdot \log_{10}(\text{BeW}_{\theta, \text{REFSENS}} \cdot \text{BeW}_{\phi, \text{REFSENS}}) \text{ (dB) for all other directions.}$$

For requirements which are to be met over the *minSENS RoAoA* absolute requirement values are offset by the following term:

$$\Delta_{\text{minSENS}} = P_{\text{REFSENS}} - \text{EIS}_{\text{minSENS}} \text{ (dB)}$$

For FR2 requirements which are to be met over the *OTA REFSENS RoAoA* absolute requirement values are offset by the following term:

$$\Delta_{\text{FR2\_REFSENS}} = -3 \text{ dB for the reference direction}$$

and

$$\Delta_{\text{FR2\_REFSENS}} = 0 \text{ dB for all other directions}$$

For *BS type 1-H* there is no requirement specified for band n46, n100, n101 and n102.

For *BS type 1-O* there is no requirement specified for bands n46, n96, n100, n101 and n102.

## 7.2 OTA sensitivity

### 7.2.1 Definition and applicability

The OTA sensitivity requirement is based upon the declaration of one or more *OTA sensitivity direction declarations* (OSDD), related to a *BS type 1-H* and *BS type 1-O receiver*.

The *BS type 1-H* and *BS type 1-O receiver* may optionally be capable of redirecting/changing the *receiver target* by means of adjusting BS settings resulting in multiple *sensitivity RoAoA*. The *sensitivity RoAoA* resulting from the current BS settings is the active *sensitivity RoAoA*.

If the BS is capable of redirecting the *receiver target* related to the OSDD then the OSDD shall include:

- *BS channel bandwidth* and declared minimum EIS level applicable to any active *sensitivity RoAoA* inside the *receiver target redirection range* in the OSDD.
- A declared *receiver target redirection range*, describing all the angles of arrival that can be addressed for the OSDD through alternative settings in the BS.
- Five declared *sensitivity RoAoA* comprising the conformance testing directions as detailed in TR 37. 941 [29].
- The receiver target reference direction.

NOTE 1: Some of the declared *sensitivity RoAoA* may coincide depending on the redirection capability.

NOTE 2: In addition to the declared *sensitivity RoAoA*, several *sensitivity RoAoA* may be implicitly defined by the *receiver target redirection range* without being explicitly declared in the OSDD.

If the BS is not capable of redirecting the *receiver target* related to the OSDD, then the OSDD includes only:

- *BS channel bandwidth* and declared minimum EIS level applicable to the *sensitivity RoAoA* in the OSDD.
- One declared active *sensitivity RoAoA*.
- The receiver target reference direction.

NOTE 3: For BS without target redirection capability, the declared (fixed) *sensitivity RoAoA* is always the active *sensitivity RoAoA*.

The OTA sensitivity EIS level declaration shall apply to each supported polarization, under the assumption of *polarization match*.

### 7.2.2 Minimum requirement

For a received signal whose AoA of the incident wave is within the active *sensitivity RoAoA* of an OSDD, the error rate criterion as described in TS 38.104 [2] clause 7.2.2 shall be met when the level of the arriving signal is equal to the minimum EIS level in the respective declared set of EIS level and *BS channel bandwidth*.

### 7.2.3 Test Purpose

The test purpose is to verify that the BS can meet the throughput requirement for a specified measurement channel at the EIS level and the range of angles of arrival declared in the OSDD.

### 7.2.4 Method of test

#### 7.2.4.1 Initial conditions

Test environment: Normal, see annex B.2.

RF channels to be tested for single carrier: M; see clause 4.9.1.

Directions to be tested:

- receiver target reference direction (D.31),
- conformance test directions (D.33).

## 7.2.4.2 Procedure

- 1) Place the BS with its manufacturer declared coordinate system reference point in the same place as calibrated point in the test system, as shown in annex E.2.1.
- 2) Align the manufacturer declared coordinate system orientation of the BS with the test system.
- 3) Align the BS with the test antenna in the declared direction to be tested.
- 4) Ensure the polarization is accounted for such that all the power from the test antenna is captured by the BS under test.
- 5) Configure the beam peak direction for the transmitter according to the declared reference beam direction pair for the appropriate beam identifier.
- 6) For FDD operation, set the BS to transmit beam(s) of the same operational band as the OSDD being tested according to the appropriate test configuration in clauses 4.7 and 4.8.
- 7) Start the signal generator for the wanted signal to transmit:
  - The test signal as specified in clause 7.2.5.
- 8) Set the test signal mean power so the calibrated radiated power at the BS Antenna Array coordinate system reference point is as specified in clause 7.2.5.
- 9) Measure the throughput according to annex A.1 for each supported polarization.
- 10) Repeat steps 3 to 9 for all OSDD(s) declared for the BS (D.23), and supported polarizations.

For multi-band capable BS and single band tests, repeat the steps above per involved band where single band test configurations and test models shall apply with no carriers activated in the other band.

## 7.2.5 Test requirements

### 7.2.5.1 General

The minimum EIS level is a declared figure (D.27, D.28) for each OSDD (D.23). The test requirement is calculated from the declared value offset by the EIS Test Tolerance specified in clause 4.1.

### 7.2.5.2 Test requirements for *BS type 1-H* and *BS type 1-O*

For each measured carrier, the throughput measured in step 9 of clause 7.2.4.2 shall be  $\geq 95$  % of the maximum throughput of the reference measurement channel as specified in annex A.1 with parameters specified in table 7.2.5.2-1.

Table 7.2.5.2-1: EIS levels

BS channel bandwidth (MHz)	Sub-carrier spacing (kHz)	Reference measurement channel (annex A.1)	OTA sensitivity level, EIS (dBm)			
			$f \leq 3.0$ GHz	$3.0$ GHz $< f \leq 4.2$ GHz	$4.2$ GHz $< f \leq 6.0$ GHz	$6.0$ GHz $< f \leq 7.125$ GHz
5, 10, 15	15	G-FR1-A1-1	Declared minimum EIS  + 1.3	Declared minimum EIS  + 1.4	Declared minimum EIS  + 1.6	Declared minimum EIS  + 1.9
10, 15	30	G-FR1-A1-2				
10, 15	60	G-FR1-A1-3				
20, 25, 30, 35, 40, 45, 50	15	G-FR1-A1-4				
20, 25, 30, 35, 40, 45, 50, 60, 70, 80, 90, 100	30	G-FR1-A1-5				
20, 25, 30, 35, 40, 45, 50, 60, 70, 80, 90, 100	60	G-FR1-A1-6				
NOTE: EIS is the power level of a single instance of the reference measurement channel. This requirement shall be met for each consecutive application of a single instance of the reference measurement channel mapped to disjoint frequency ranges with a width corresponding to the number of resource blocks of the reference measurement channel each, except for one instance that might overlap one other instance to cover the full <i>BS channel bandwidth</i> .						

Table 7.2.5-2: Void

Table 7.2.5-3: EIS levels for band n96 for BS Type 1-H

BS channel bandwidth (MHz)	Sub-carrier spacing (kHz)	Reference measurement channel	OTA sensitivity level, EIS (dBm)
20	15	G-FR1-A1-14 (Note 2)	Declared minimum EIS + 1.9
	30	G-FR1-A1-15 (Note 2)	
	60	G-FR1-A1-6 (Note 1)	
40	15	G-FR1-A1-16 (Note 2)	
	30	G-FR1-A1-17 (Note 2)	
	60	G-FR1-A1-6 (Note 1)	
60	30	G-FR1-A1-18 (Note 2)	
	60	G-FR1-A1-6 (Note 1)	
80	30	G-FR1-A1-19 (Note 2)	
	60	G-FR1-A1-6 (Note 1)	
NOTE 1: EIS is the power level of a single instance of the reference measurement channel. This requirement shall be met for each consecutive application of a single instance of the reference measurement channel mapped to disjoint frequency ranges with a width corresponding to the number of resource blocks of the reference measurement channel each, except for one instance that might overlap one other instance to cover the full <i>BS channel bandwidth</i> .			
NOTE 2: EIS is the power level of a single instance of the reference measurement channel. This requirement shall be met for each interleaved application of a single instance of the reference measurement channel mapped to disjoint frequency ranges with a width corresponding to the number of resource blocks of the reference measurement channel each, except for one instance that might overlap one other instance to cover the full <i>BS channel bandwidth</i> .			

### 7.2.5.3 Test requirements for *BS type 2-O*

There is no OTA sensitivity requirement for FR2, the OTA sensitivity is the same as the OTA reference sensitivity in clause 7.3.

## 7.3 OTA reference sensitivity level

### 7.3.1 Definition and applicability

The OTA REFSENS requirement is a directional requirement and is intended to ensure the minimum OTA reference sensitivity level for a declared *OTA REFSENS RoAoA*. The OTA reference sensitivity power level  $EIS_{REFSENS}$  is the minimum mean power received at the RIB at which a reference performance requirement shall be met for a specified reference measurement channel.

The OTA REFSENS EIS level declaration shall apply to each supported polarization, under the assumption of *polarization match*.

### 7.3.2 Minimum requirement

For *BS type 1-O* the minimum requirement is in TS 38.104 [2], clause 10.3.2.

For *BS type 2-O* the minimum requirement is in TS 38.104 [2], clause 10.3.3.

### 7.3.3 Test Purpose

The test purpose is to verify that the BS can meet the throughput requirement for a specified measurement channel at the  $EIS_{REFSENS}$  level and the range of angles of arrival within the *OTA REFSENS RoAoA*.

### 7.3.4 Method of test

#### 7.3.4.1 Initial conditions

Test environment: Normal, see annex B.2.

RF channels to be tested for single carrier:

- B, M and T; see clause 4.9.1.

Directions to be tested:

- OTA REFSENS receiver target reference direction (D.54),
- OTA REFSENS conformance test directions (D.55).

#### 7.3.4.2 Procedure

- 1) Place the BS with its manufacturer declared coordinate system reference point in the same place as calibrated point in the test system, as shown in annex E.2.1.
- 2) Align the manufacturer declared coordinate system orientation of the BS with the test system.
- 3) Align the BS with the test antenna in the declared direction to be tested.
- 4) Ensure the polarization is accounted for such that all the power from the test antenna is captured by the BS under test.
- 5) Configure the beam peak direction for the transmitter according to the declared reference beam direction pair for the appropriate beam identifier.
- 6) For FDD operation, set the BS to transmit beam(s) of the same operational band as the *OTA REFSENS RoAoA* being tested according to the appropriate test configuration in clauses 4.7 and 4.8.
- 7) Start the signal generator for the wanted signal to transmit:
  - The test signal as specified in clause 7.3.5.

- 8) Set the test signal mean power so the calibrated radiated power at the BS Antenna Array coordinate system reference point is as specified in clause 7.3.5.
- 9) Measure the throughput according to annex A.1 for each supported polarization.
- 10) Repeat steps 3 to 9 for all OTA REFSSENS conformance test directions of the BS (D.55), and supported polarizations.

For multi-band capable FR1 BS and single band tests, repeat the steps above per involved band where single band test configurations and test models shall apply with no carriers activated in the other band.

## 7.3.5 Test requirements

### 7.3.5.1 General

The FR1 EIS<sub>REFSENS</sub> level is the conducted REFSSENS requirement value offset by  $\Delta_{OTAREFSSENS}$ . The test requirement is calculated from the EIS<sub>REFSENS</sub> level offset by the EIS<sub>REFSENS</sub> Test Tolerance specified in clause 4.1.

### 7.3.5.2 Test requirements for BS type 1-0

For each measured carrier, the throughput measured in step 9 of clause 7.3.4.2 shall be  $\geq 95\%$  of the maximum throughput of the reference measurement channel as specified in annex A.1 with parameters specified in tables 7.3.5.2-1 to 7.3.5.2-3.

**Table 7.3.5.2-1: Wide Area BS EIS<sub>REFSENS</sub> levels**

BS channel bandwidth (MHz)	Sub-carrier spacing (kHz)	Reference measurement channel (annex A.1)	OTA reference sensitivity level, EIS <sub>REFSENS</sub> (dBm)			
			$f \leq 3.0$ GHz	$3.0$ GHz $< f \leq 4.2$ GHz	$4.2$ GHz $< f \leq 6.0$ GHz	$6.0$ GHz $< f \leq 7.125$ GHz
5, 10, 15	15	G-FR1-A1-1	-100.4 – $\Delta_{OTAREFSSENS}$	-100.3 – $\Delta_{OTAREFSSENS}$	-100.1 – $\Delta_{OTAREFSSENS}$	NA
10, 15	30	G-FR1-A1-2	-100.5 – $\Delta_{OTAREFSSENS}$	-100.4 – $\Delta_{OTAREFSSENS}$	-100.2 – $\Delta_{OTAREFSSENS}$	NA
10, 15	60	G-FR1-A1-3	-97.6 – $\Delta_{OTAREFSSENS}$	-97.5 – $\Delta_{OTAREFSSENS}$	-97.3 – $\Delta_{OTAREFSSENS}$	NA
20, 25, 30, 35, 40, 45, 50	15	G-FR1-A1-4	-94 – $\Delta_{OTAREFSSENS}$	-93.9 – $\Delta_{OTAREFSSENS}$	-93.7 – $\Delta_{OTAREFSSENS}$	-92.4 – $\Delta_{OTAREFSSENS}$
20, 25, 30, 35, 40, 45, 50, 60, 70, 80, 90, 100	30	G-FR1-A1-5	-94.3 – $\Delta_{OTAREFSSENS}$	-94.2 – $\Delta_{OTAREFSSENS}$	-94 – $\Delta_{OTAREFSSENS}$	-92.7 – $\Delta_{OTAREFSSENS}$
20, 25, 30, 35, 40, 45, 50, 60, 70, 80, 90, 100	60	G-FR1-A1-6	-94.4 – $\Delta_{OTAREFSSENS}$	-94.3 – $\Delta_{OTAREFSSENS}$	-94.1 – $\Delta_{OTAREFSSENS}$	-92.8 – $\Delta_{OTAREFSSENS}$

NOTE: EIS<sub>REFSENS</sub> is the power level of a single instance of the reference measurement channel. This requirement shall be met for each consecutive application of a single instance of the reference measurement channel mapped to disjoint frequency ranges with a width corresponding to the number of resource blocks of the reference measurement channel each, except for one instance that might overlap one other instance to cover the full BS channel bandwidth.

Table 7.3.5.2-2: Medium Range BS EIS<sub>REFSENS</sub> levels

BS channel bandwidth (MHz)	Sub-carrier spacing (kHz)	Reference measurement channel (annex A.1)	EIS <sub>REFSENS</sub> (dBm)			
			f ≤ 3.0 GHz	3.0 GHz < f ≤ 4.2 GHz	4.2 GHz < f ≤ 6.0 GHz	6.0 GHz < f ≤ 7.125 GHz
5, 10, 15	15	G-FR1-A1-1	-95.4 – Δ <sub>OTAREFSNS</sub>	-95.3 – Δ <sub>OTAREFSNS</sub>	-95.1 – Δ <sub>OTAREFSNS</sub>	NA
10, 15	30	G-FR1-A1-2	-95.5 – Δ <sub>OTAREFSNS</sub>	-95.4 – Δ <sub>OTAREFSNS</sub>	-95.2 – Δ <sub>OTAREFSNS</sub>	NA
10, 15	60	G-FR1-A1-3	-92.6 – Δ <sub>OTAREFSNS</sub>	-92.5 – Δ <sub>OTAREFSNS</sub>	-92.3 – Δ <sub>OTAREFSNS</sub>	NA
20, 25, 30, 35, 40, 45, 50	15	G-FR1-A1-4	-89 – Δ <sub>OTAREFSNS</sub>	-88.9 – Δ <sub>OTAREFSNS</sub>	-88.7 – Δ <sub>OTAREFSNS</sub>	-87.4 – Δ <sub>OTAREFSNS</sub>
20, 25, 30, 35, 40, 45, 50, 60, 70, 80, 90, 100	30	G-FR1-A1-5	-89.3 – Δ <sub>OTAREFSNS</sub>	-89.2 – Δ <sub>OTAREFSNS</sub>	-89 – Δ <sub>OTAREFSNS</sub>	-87.7 – Δ <sub>OTAREFSNS</sub>
20, 25, 30, 35, 40, 45, 50, 60, 70, 80, 90, 100	60	G-FR1-A1-6	-89.4 – Δ <sub>OTAREFSNS</sub>	-89.3 – Δ <sub>OTAREFSNS</sub>	-89.1 – Δ <sub>OTAREFSNS</sub>	-87.8 – Δ <sub>OTAREFSNS</sub>

NOTE: EIS<sub>REFSENS</sub> is the power level of a single instance of the reference measurement channel. This requirement shall be met for each consecutive application of a single instance of the reference measurement channel mapped to disjoint frequency ranges with a width corresponding to the number of resource blocks of the reference measurement channel each, except for one instance that might overlap one other instance to cover the full *BS channel bandwidth*.

Table 7.3.5.2-3: Local Area BS EIS<sub>REFSENS</sub> levels

BS channel bandwidth (MHz)	Sub-carrier spacing (kHz)	Reference measurement channel (annex A.1)	OTA reference sensitivity level, EIS <sub>REFSENS</sub> (dBm)			
			f ≤ 3.0 GHz	3.0 GHz < f ≤ 4.2 GHz	4.2 GHz < f ≤ 6.0 GHz	6.0 GHz < f ≤ 7.125 GHz
5, 10, 15	15	G-FR1-A1-1	-92.4 – Δ <sub>OTAREFSNS</sub>	-92.3 – Δ <sub>OTAREFSNS</sub>	-92.1 – Δ <sub>OTAREFSNS</sub>	NA
10, 15	30	G-FR1-A1-2	-92.5 – Δ <sub>OTAREFSNS</sub>	-92.4 – Δ <sub>OTAREFSNS</sub>	-92.2 – Δ <sub>OTAREFSNS</sub>	NA
10, 15	60	G-FR1-A1-3	-89.6 – Δ <sub>OTAREFSNS</sub>	-89.5 – Δ <sub>OTAREFSNS</sub>	-89.3 – Δ <sub>OTAREFSNS</sub>	NA
20, 25, 30, 35, 40, 45, 50	15	G-FR1-A1-4	-86 – Δ <sub>OTAREFSNS</sub>	-85.9 – Δ <sub>OTAREFSNS</sub>	-85.7 – Δ <sub>OTAREFSNS</sub>	-84.4 – Δ <sub>OTAREFSNS</sub>
20, 25, 30, 35, 40, 45, 50, 60, 70, 80, 90, 100	30	G-FR1-A1-5	-86.3 – Δ <sub>OTAREFSNS</sub>	-86.2 – Δ <sub>OTAREFSNS</sub>	-86 – Δ <sub>OTAREFSNS</sub>	-84.7 – Δ <sub>OTAREFSNS</sub>
20, 25, 30, 35, 40, 45, 50, 60, 70, 80, 90, 100	60	G-FR1-A1-6	-86.4 – Δ <sub>OTAREFSNS</sub>	-86.3 – Δ <sub>OTAREFSNS</sub>	-86.1 – Δ <sub>OTAREFSNS</sub>	-84.8 – Δ <sub>OTAREFSNS</sub>

NOTE: EIS<sub>REFSENS</sub> is the power level of a single instance of the reference measurement channel. This requirement shall be met for each consecutive application of a single instance of the reference measurement channel mapped to disjoint frequency ranges with a width corresponding to the number of resource blocks of the reference measurement channel each, except for one instance that might overlap one other instance to cover the full *BS channel bandwidth*.

### 7.3.5.3 Test requirements for BS type 2-0

The throughput shall be ≥ 95% of the maximum throughput of the reference measurement channel as specified in annex A.1 when the OTA test signal is at the corresponding EIS<sub>REFSENS</sub> level and arrives from any direction within the *OTA REFSENS RoAoA*.

EIS<sub>REFSENS</sub> levels are derived from a single declared basis level EIS<sub>REFSENS\_50M</sub>, which is based on a reference measurement channel with 50 MHz *BS channel bandwidth*. EIS<sub>REFSENS\_50M</sub> itself is not a requirement and although it is based on a reference measurement channel with 50 MHz *BS channel bandwidth* it does not imply that BS has to support 50 MHz *BS channel bandwidth*.



For Wide Area BS,  $EIS_{REFSENS\_50M}$  is an integer value in the range -96 to -119 dBm. The specific value is declared by the vendor.

For Medium Range BS,  $EIS_{REFSENS\_50M}$  is an integer value in the range -91 to -114 dBm. The specific value is declared by the vendor.

For Local Area BS,  $EIS_{REFSENS\_50M}$  is an integer value in the range -86 to -109 dBm. The specific value is declared by the vendor.

**Table 7.3.5.3-1: FR2-1 OTA reference sensitivity requirement applicable in the frequency range 24.25 – 43.5 GHz**

BS channel bandwidth (MHz)	Sub-carrier spacing (kHz)	Reference measurement channel (annex A.1)	OTA reference sensitivity level, $EIS_{REFSENS}$ (dBm)
50, 100, 200	60	G-FR2-A1-1	$EIS_{REFSENS\_50M} + 2.4 + \Delta_{FR2\_REFSENS}$
50	120	G-FR2-A1-2	$EIS_{REFSENS\_50M} + 2.4 + \Delta_{FR2\_REFSENS}$
100, 200, 400	120	G-FR2-A1-3	$EIS_{REFSENS\_50M} + 3 + 2.4 + \Delta_{FR2\_REFSENS}$

NOTE 1:  $EIS_{REFSENS}$  is the power level of a single instance of the reference measurement channel. This requirement shall be met for each consecutive application of a single instance of the reference measurement channel mapped to disjoint frequency ranges with a width corresponding to the number of resource blocks of the reference measurement channel each, except for one instance that might overlap one other instance to cover the full *BS channel bandwidth*.

NOTE 2: The declared  $EIS_{REFSENS\_50M}$  shall be within the range specified in table 10.3.3-2.

**Table 7.3.5.3-2: FR2-1 OTA reference sensitivity requirement applicable in the frequency range 43.5 – 48.2 GHz**

BS channel bandwidth (MHz)	Sub-carrier spacing (kHz)	Reference measurement channel (annex A.1)	OTA reference sensitivity level, $EIS_{REFSENS}$ (dBm)
50, 100, 200	60	G-FR2-A1-1	$EIS_{REFSENS\_50M} + 3.5 + \Delta_{FR2\_REFSENS}$
50	120	G-FR2-A1-2	$EIS_{REFSENS\_50M} + 3.5 + \Delta_{FR2\_REFSENS}$
100, 200, 400	120	G-FR2-A1-3	$EIS_{REFSENS\_50M} + 3 + 3.5 + \Delta_{FR2\_REFSENS}$

NOTE 1:  $EIS_{REFSENS}$  is the power level of a single instance of the reference measurement channel. This requirement shall be met for each consecutive application of a single instance of the reference measurement channel mapped to disjoint frequency ranges with a width corresponding to the number of resource blocks of the reference measurement channel each, except for one instance that might overlap one other instance to cover the full *BS channel bandwidth*.

NOTE 2: The declared  $EIS_{REFSENS\_50M}$  shall be within the range specified in table 10.3.3-2.

**Table 7.3.5.3-3 FR2-2 OTA reference sensitivity requirement applicable in the frequency range 52.6 – 71 GHz**

BS channel bandwidth (MHz)	Sub-carrier spacing (kHz)	Reference measurement channel (annex A.1)	OTA reference sensitivity level, $EIS_{REFSENS}$ (dBm)
100,400	120	G-FR2-A1-3	$EIS_{REFSENS\_50M} + 3 + 3.0 + \Delta_{FR2\_REFSENS}$
400, 800, 1600	480	G-FR2-A1-6	$EIS_{REFSENS\_50M} + 9 + 3.0 + \Delta_{FR2\_REFSENS}$
400, 800, 1600, 2000	960	G-FR2-A1-7	$EIS_{REFSENS\_50M} + 9 + 3.0 + \Delta_{FR2\_REFSENS}$
<p>NOTE 1: <math>EIS_{REFSENS}</math> is the power level of a single instance of the reference measurement channel. This requirement shall be met for each consecutive application of a single instance of the reference measurement channel mapped to disjoint frequency ranges with a width corresponding to the number of resource blocks of the reference measurement channel each, except for one instance that might overlap one other instance to cover the full <i>BS channel bandwidth</i>.</p> <p>NOTE 2: The declared <math>EIS_{REFSENS\_50M}</math> shall be within the range specified in table 10.3.3-2.</p>			

## 7.4 OTA dynamic range

### 7.4.1 Definition and applicability

The OTA dynamic range is a measure of the capability of the receiver unit to receive a wanted signal in the presence of an interfering signal inside the received *BS channel bandwidth*.

The requirement shall apply at the RIB when the AoA of the incident wave of a received signal and the interfering signal are from the same direction and are within the *OTA REFSENS RoAoA*.

The wanted and interfering signals apply to each supported polarization, under the assumption of *polarization match*.

### 7.4.2 Minimum requirement

For *BS type I-O*, the minimum requirement is in TS 38.104 [2], clause 10.4.2.

### 7.4.3 Test purpose

The test purpose is to verify that at the BS receiver dynamic range, the relative throughput shall fulfil the specified limit.

### 7.4.4 Method of test

#### 7.4.4.1 Initial conditions

Test environment: Normal: see annex B.2.

RF channels to be tested for single carrier: M; see clause 4.9.1.

Directions to be tested: OTA REFSENS receiver target reference direction (D.54).

#### 7.4.4.2 Procedure

- 1) Place the BS with its manufacturer declared coordinate system reference point in the same place as calibrated point in the test system, as shown in annex E.2.2.
- 2) Align the manufacturer declared coordinate system orientation of the BS with the test system.
- 3) Align the BS with the test antenna in the declared direction to be tested.

- 4) Ensure the polarization is accounted for such that all the power from the test antenna is captured by the BS under test.
- 5) Configure the beam peak direction for the transmitter according to the declared reference beam direction pair for the appropriate beam identifier.
- 6) For FDD operation, set the BS to transmit beam(s) of the same operational band as the *OTA REFSENS RoAoA* being tested according to the appropriate test configuration in clauses 4.7 and 4.8.
- 7) Set the test signal mean power so that the calibrated radiated power at the BS Antenna Array coordinate system reference point is as follows:
  - a) Set the signal generator for the wanted signal to transmit as specified in table 7.4.5.2-1 to 7.4.5.2-3.
  - b) Set the signal generator for the AWGN interfering signal at the same frequency as the wanted signal to transmit as specified in table 7.4.5.2-1 to 7.4.5.2-3.
- 8) Measure the throughput according to annex A.2 for each supported polarization.

For *multi-band RIB(s)* and single band tests, repeat the steps above per involved band where single band test configurations and test models shall apply with no carriers activated in the other band.

## 7.4.5 Test requirement

### 7.4.5.1 General

The test requirement is calculated from the OTA wanted signal mean power level offset by the OTA dynamic range Test Tolerance specified in clause 4.1.

### 7.4.5.2 Test requirements for *BS type 1-0*

For each measured carrier, the throughput measured in step 6 of clause 7.4.4.2 shall be  $\geq 95$  % of the maximum throughput of the reference measurement channel as specified in annex A.2 with parameters specified in tables 7.4.5.2-1 to 7.4.5.2-3a.

**Table 7.4.5.2-1: Wide Area BS dynamic range for  $f \leq 6.0$  GHz**

BS channel bandwidth (MHz)	Subcarrier spacing (kHz)	Reference measurement channel (annex A.2)	Wanted signal mean power (dBm)			Interfering signal mean power (dBm) / $BW_{Config}$	Type of interfering signal
			$f \leq 3.0$ GHz	$3.0$ GHz $< f \leq 4.2$ GHz	$4.2$ GHz $< f \leq 6.0$ GHz		
5	15	G-FR1-A2-1	-70.4 – $\Delta_{OTAREFSENS}$	-70.4 – $\Delta_{OTAREFSENS}$	-70.4 – $\Delta_{OTAREFSENS}$	-82.5 – $\Delta_{OTAREFSENS}$	AWGN
	30	G-FR1-A2-2	-71.1 – $\Delta_{OTAREFSENS}$	-71.1 – $\Delta_{OTAREFSENS}$	-71.1 – $\Delta_{OTAREFSENS}$		
10	15	G-FR1-A2-1	-70.4 – $\Delta_{OTAREFSENS}$	-70.4 – $\Delta_{OTAREFSENS}$	-70.4 – $\Delta_{OTAREFSENS}$	-79.3 – $\Delta_{OTAREFSENS}$	AWGN
	30	G-FR1-A2-2	-71.1 – $\Delta_{OTAREFSENS}$	-71.1 – $\Delta_{OTAREFSENS}$	-71.1 – $\Delta_{OTAREFSENS}$		
	60	G-FR1-A2-3	-68.1 – $\Delta_{OTAREFSENS}$	-68.1 – $\Delta_{OTAREFSENS}$	-68.1 – $\Delta_{OTAREFSENS}$		
15	15	G-FR1-A2-1	-70.4 – $\Delta_{OTAREFSENS}$	-70.4 – $\Delta_{OTAREFSENS}$	-70.4 – $\Delta_{OTAREFSENS}$	-77.5 – $\Delta_{OTAREFSENS}$	AWGN
	30	G-FR1-A2-2	-71.1 – $\Delta_{OTAREFSENS}$	-71.1 – $\Delta_{OTAREFSENS}$	-71.1 – $\Delta_{OTAREFSENS}$		
	60	G-FR1-A2-3	-68.1 – $\Delta_{OTAREFSENS}$	-68.1 – $\Delta_{OTAREFSENS}$	-68.1 – $\Delta_{OTAREFSENS}$		
20	15	G-FR1-A2-4	-64.2 – $\Delta_{OTAREFSENS}$	-64.2 – $\Delta_{OTAREFSENS}$	-64.2 – $\Delta_{OTAREFSENS}$	-76.2 – $\Delta_{OTAREFSENS}$	AWGN
	30	G-FR1-A2-5	-64.2 – $\Delta_{OTAREFSENS}$	-64.2 – $\Delta_{OTAREFSENS}$	-64.2 – $\Delta_{OTAREFSENS}$		
	60	G-FR1-A2-6	-64.5 – $\Delta_{OTAREFSENS}$	-64.5 – $\Delta_{OTAREFSENS}$	-64.5 – $\Delta_{OTAREFSENS}$		
25	15	G-FR1-A2-4	-64.2 – $\Delta_{OTAREFSENS}$	-64.2 – $\Delta_{OTAREFSENS}$	-64.2 – $\Delta_{OTAREFSENS}$	-75.2 – $\Delta_{OTAREFSENS}$	AWGN
	30	G-FR1-A2-5	-64.2 – $\Delta_{OTAREFSENS}$	-64.2 – $\Delta_{OTAREFSENS}$	-64.2 – $\Delta_{OTAREFSENS}$		
	60	G-FR1-A2-6	-64.5 – $\Delta_{OTAREFSENS}$	-64.5 – $\Delta_{OTAREFSENS}$	-64.5 – $\Delta_{OTAREFSENS}$		
30	15	G-FR1-A2-4	-64.2 – $\Delta_{OTAREFSENS}$	-64.2 – $\Delta_{OTAREFSENS}$	-64.2 – $\Delta_{OTAREFSENS}$	-74.4 – $\Delta_{OTAREFSENS}$	AWGN
	30	G-FR1-A2-5	-64.2 – $\Delta_{OTAREFSENS}$	-64.2 – $\Delta_{OTAREFSENS}$	-64.2 – $\Delta_{OTAREFSENS}$		
	60	G-FR1-A2-6	-64.5 – $\Delta_{OTAREFSENS}$	-64.5 – $\Delta_{OTAREFSENS}$	-64.5 – $\Delta_{OTAREFSENS}$		
35	15	G-FR1-A2-4	-64.2 – $\Delta_{OTAREFSENS}$	-64.2 – $\Delta_{OTAREFSENS}$	-64.2 – $\Delta_{OTAREFSENS}$	-73.7– $\Delta_{OTAREFSENS}$	AWGN
	30	G-FR1-A2-5	-64.2 – $\Delta_{OTAREFSENS}$	-64.2 – $\Delta_{OTAREFSENS}$	-64.2 – $\Delta_{OTAREFSENS}$		
	60	G-FR1-A2-6	-64.5 – $\Delta_{OTAREFSENS}$	-64.5 – $\Delta_{OTAREFSENS}$	-64.5 – $\Delta_{OTAREFSENS}$		
40	15	G-FR1-A2-4	-64.2 – $\Delta_{OTAREFSENS}$	-64.2 – $\Delta_{OTAREFSENS}$	-64.2 – $\Delta_{OTAREFSENS}$	-73.1 – $\Delta_{OTAREFSENS}$	AWGN
	30	G-FR1-A2-5	-64.2 – $\Delta_{OTAREFSENS}$	-64.2 – $\Delta_{OTAREFSENS}$	-64.2 – $\Delta_{OTAREFSENS}$		
	60	G-FR1-A2-6	-64.5 – $\Delta_{OTAREFSENS}$	-64.5 – $\Delta_{OTAREFSENS}$	-64.5 – $\Delta_{OTAREFSENS}$		
45	15	G-FR1-A2-4	-64.2 – $\Delta_{OTAREFSENS}$	-64.2 – $\Delta_{OTAREFSENS}$	-64.2 – $\Delta_{OTAREFSENS}$	-72.6– $\Delta_{OTAREFSENS}$	AWGN
	30	G-FR1-A2-5	-64.2 – $\Delta_{OTAREFSENS}$	-64.2 – $\Delta_{OTAREFSENS}$	-64.2 – $\Delta_{OTAREFSENS}$		
	60	G-FR1-A2-6	-64.5 – $\Delta_{OTAREFSENS}$	-64.5 – $\Delta_{OTAREFSENS}$	-64.5 – $\Delta_{OTAREFSENS}$		
50	15	G-FR1-A2-4	-64.2 – $\Delta_{OTAREFSENS}$	-64.2 – $\Delta_{OTAREFSENS}$	-64.2 – $\Delta_{OTAREFSENS}$	-72.1 – $\Delta_{OTAREFSENS}$	AWGN
	30	G-FR1-A2-5	-64.2 – $\Delta_{OTAREFSENS}$	-64.2 – $\Delta_{OTAREFSENS}$	-64.2 – $\Delta_{OTAREFSENS}$		
	60	G-FR1-A2-6	-64.5 – $\Delta_{OTAREFSENS}$	-64.5 – $\Delta_{OTAREFSENS}$	-64.5 – $\Delta_{OTAREFSENS}$		
60	30	G-FR1-A2-5	-64.2 – $\Delta_{OTAREFSENS}$	-64.2 – $\Delta_{OTAREFSENS}$	-64.2 – $\Delta_{OTAREFSENS}$	-71.3 – $\Delta_{OTAREFSENS}$	AWGN
	60	G-FR1-A2-6	-64.5 – $\Delta_{OTAREFSENS}$	-64.5 – $\Delta_{OTAREFSENS}$	-64.5 – $\Delta_{OTAREFSENS}$		

70	30	G-FR1-A2-5	-64.2 – $\Delta_{\text{OTAREFSENS}}$	-64.2 – $\Delta_{\text{OTAREFSENS}}$	-64.2 – $\Delta_{\text{OTAREFSENS}}$	-70.7 – $\Delta_{\text{OTAREFSENS}}$	AWGN
	60	G-FR1-A2-6	-64.5 – $\Delta_{\text{OTAREFSENS}}$	-64.5 – $\Delta_{\text{OTAREFSENS}}$	-64.5 – $\Delta_{\text{OTAREFSENS}}$		
80	30	G-FR1-A2-5	-64.2 – $\Delta_{\text{OTAREFSENS}}$	-64.2 – $\Delta_{\text{OTAREFSENS}}$	-64.2 – $\Delta_{\text{OTAREFSENS}}$	-70.1 – $\Delta_{\text{OTAREFSENS}}$	AWGN
	60	G-FR1-A2-6	-64.5 – $\Delta_{\text{OTAREFSENS}}$	-64.5 – $\Delta_{\text{OTAREFSENS}}$	-64.5 – $\Delta_{\text{OTAREFSENS}}$		
90	30	G-FR1-A2-5	-64.2 – $\Delta_{\text{OTAREFSENS}}$	-64.2 – $\Delta_{\text{OTAREFSENS}}$	-64.2 – $\Delta_{\text{OTAREFSENS}}$	-69.5 – $\Delta_{\text{OTAREFSENS}}$	AWGN
	60	G-FR1-A2-6	-64.5 – $\Delta_{\text{OTAREFSENS}}$	-64.5 – $\Delta_{\text{OTAREFSENS}}$	-64.5 – $\Delta_{\text{OTAREFSENS}}$		
100	30	G-FR1-A2-5	-64.2 – $\Delta_{\text{OTAREFSENS}}$	-64.2 – $\Delta_{\text{OTAREFSENS}}$	-64.2 – $\Delta_{\text{OTAREFSENS}}$	-69.1 – $\Delta_{\text{OTAREFSENS}}$	AWGN
	60	G-FR1-A2-6	-64.5 – $\Delta_{\text{OTAREFSENS}}$	-64.5 – $\Delta_{\text{OTAREFSENS}}$	-64.5 – $\Delta_{\text{OTAREFSENS}}$		

NOTE: The wanted signal mean power is the power level of a single instance of the corresponding reference measurement channel. This requirement shall be met for each consecutive application of a single instance of the reference measurement channel mapped to disjoint frequency ranges with a width corresponding to the number of resource blocks of the reference measurement channel each, except for one instance that might overlap one other instance to cover the full *BS channel bandwidth*.

Table 7.4.5.2-1a: Wide Area BS dynamic range for  $6.0 < f \leq 7.125$  GHz

BS channel bandwidth (MHz)	Subcarrier spacing (kHz)	Reference measurement channel (annex A.2)	Wanted signal mean power (dBm)	Interfering signal mean power (dBm) / $BW_{Config}$	Type of interfering signal
20	15	G-FR1-A2-4	-63.2 – $\Delta_{OTAREFSENS}$	-75.2 – $\Delta_{OTAREFSENS}$	AWGN
	30	G-FR1-A2-5	-63.2 – $\Delta_{OTAREFSENS}$		
	60	G-FR1-A2-6	-63.5 – $\Delta_{OTAREFSENS}$		
30	15	G-FR1-A2-4	-63.2 – $\Delta_{OTAREFSENS}$	-73.4 – $\Delta_{OTAREFSENS}$	AWGN
	30	G-FR1-A2-5	-63.2 – $\Delta_{OTAREFSENS}$		
	60	G-FR1-A2-6	-63.5 – $\Delta_{OTAREFSENS}$		
40	15	G-FR1-A2-4	-63.2 – $\Delta_{OTAREFSENS}$	-72.1 – $\Delta_{OTAREFSENS}$	AWGN
	30	G-FR1-A2-5	-63.2 – $\Delta_{OTAREFSENS}$		
	60	G-FR1-A2-6	-63.5 – $\Delta_{OTAREFSENS}$		
50	15	G-FR1-A2-4	-63.2 – $\Delta_{OTAREFSENS}$	-71.1 – $\Delta_{OTAREFSENS}$	AWGN
	30	G-FR1-A2-5	-63.2 – $\Delta_{OTAREFSENS}$		
	60	G-FR1-A2-6	-63.5 – $\Delta_{OTAREFSENS}$		
60	30	G-FR1-A2-5	-63.2 – $\Delta_{OTAREFSENS}$	-70.3 – $\Delta_{OTAREFSENS}$	AWGN
	60	G-FR1-A2-6	-63.5 – $\Delta_{OTAREFSENS}$		
70	30	G-FR1-A2-5	-63.2 – $\Delta_{OTAREFSENS}$	-69.7 – $\Delta_{OTAREFSENS}$	AWGN
	60	G-FR1-A2-6	-63.5 – $\Delta_{OTAREFSENS}$		
80	30	G-FR1-A2-5	-63.2 – $\Delta_{OTAREFSENS}$	-69.1 – $\Delta_{OTAREFSENS}$	AWGN
	60	G-FR1-A2-6	-63.5 – $\Delta_{OTAREFSENS}$		
90	30	G-FR1-A2-5	-63.2 – $\Delta_{OTAREFSENS}$	-68.5 – $\Delta_{OTAREFSENS}$	AWGN
	60	G-FR1-A2-6	-63.5 – $\Delta_{OTAREFSENS}$		
100	30	G-FR1-A2-5	-63.2 – $\Delta_{OTAREFSENS}$	-68.1 – $\Delta_{OTAREFSENS}$	AWGN
	60	G-FR1-A2-6	-63.5 – $\Delta_{OTAREFSENS}$		
<p>NOTE: The wanted signal mean power is the power level of a single instance of the corresponding reference measurement channel. This requirement shall be met for each consecutive application of a single instance of the reference measurement channel mapped to disjoint frequency ranges with a width corresponding to the number of resource blocks of the reference measurement channel each, except for one instance that might overlap one other instance to cover the full <i>BS channel bandwidth</i>.</p>					

**Table 7.4.5.2-2: Medium Range BS dynamic range for  $f \leq 6.0$  GHz**



BS channel bandwidth (MHz)	Subcarrier spacing (kHz)	Reference measurement channel (annex A.2)	Wanted signal mean power (dBm)			Interfering signal mean power (dBm) / BW <sub>Config</sub>	Type of interfering signal
			f ≤ 3.0 GHz	3.0 GHz < f ≤ 4.2 GHz	4.2 GHz < f ≤ 6.0 GHz		
5	15	G-FR1-A2-1	-65.4 – Δ <sub>OTAREFSENS</sub>	-65.4 – Δ <sub>OTAREFSENS</sub>	-65.4 – Δ <sub>OTAREFSENS</sub>	-77.5 – Δ <sub>OTAREFSENS</sub>	AWGN
	30	G-FR1-A2-2	-66.1 – Δ <sub>OTAREFSENS</sub>	-66.1 – Δ <sub>OTAREFSENS</sub>	-66.1 – Δ <sub>OTAREFSENS</sub>		
10	15	G-FR1-A2-1	-65.4 – Δ <sub>OTAREFSENS</sub>	-65.4 – Δ <sub>OTAREFSENS</sub>	-65.4 – Δ <sub>OTAREFSENS</sub>	-74.3 – Δ <sub>OTAREFSENS</sub>	AWGN
	30	G-FR1-A2-2	-66.1 – Δ <sub>OTAREFSENS</sub>	-66.1 – Δ <sub>OTAREFSENS</sub>	-66.1 – Δ <sub>OTAREFSENS</sub>		
	60	G-FR1-A2-3	-63.1 – Δ <sub>OTAREFSENS</sub>	-63.1 – Δ <sub>OTAREFSENS</sub>	-63.1 – Δ <sub>OTAREFSENS</sub>		
15	15	G-FR1-A2-1	-65.4 – Δ <sub>OTAREFSENS</sub>	-65.4 – Δ <sub>OTAREFSENS</sub>	-65.4 – Δ <sub>OTAREFSENS</sub>	-72.5 – Δ <sub>OTAREFSENS</sub>	AWGN
	30	G-FR1-A2-2	-66.1 – Δ <sub>OTAREFSENS</sub>	-66.1 – Δ <sub>OTAREFSENS</sub>	-66.1 – Δ <sub>OTAREFSENS</sub>		
	60	G-FR1-A2-3	-63.1 – Δ <sub>OTAREFSENS</sub>	-63.1 – Δ <sub>OTAREFSENS</sub>	-63.1 – Δ <sub>OTAREFSENS</sub>		
20	15	G-FR1-A2-4	-59.2 – Δ <sub>OTAREFSENS</sub>	-59.2 – Δ <sub>OTAREFSENS</sub>	-59.2 – Δ <sub>OTAREFSENS</sub>	-71.2 – Δ <sub>OTAREFSENS</sub>	AWGN
	30	G-FR1-A2-5	-59.2 – Δ <sub>OTAREFSENS</sub>	-59.2 – Δ <sub>OTAREFSENS</sub>	-59.2 – Δ <sub>OTAREFSENS</sub>		
	60	G-FR1-A2-6	-59.5 – Δ <sub>OTAREFSENS</sub>	-59.5 – Δ <sub>OTAREFSENS</sub>	-59.5 – Δ <sub>OTAREFSENS</sub>		
25	15	G-FR1-A2-4	-59.2 – Δ <sub>OTAREFSENS</sub>	-59.2 – Δ <sub>OTAREFSENS</sub>	-59.2 – Δ <sub>OTAREFSENS</sub>	-70.2 – Δ <sub>OTAREFSENS</sub>	AWGN
	30	G-FR1-A2-5	-59.2 – Δ <sub>OTAREFSENS</sub>	-59.2 – Δ <sub>OTAREFSENS</sub>	-59.2 – Δ <sub>OTAREFSENS</sub>		
	60	G-FR1-A2-6	-59.5 – Δ <sub>OTAREFSENS</sub>	-59.5 – Δ <sub>OTAREFSENS</sub>	-59.5 – Δ <sub>OTAREFSENS</sub>		
30	15	G-FR1-A2-4	-59.2 – Δ <sub>OTAREFSENS</sub>	-59.2 – Δ <sub>OTAREFSENS</sub>	-59.2 – Δ <sub>OTAREFSENS</sub>	-69.4 – Δ <sub>OTAREFSENS</sub>	AWGN
	30	G-FR1-A2-5	-59.2 – Δ <sub>OTAREFSENS</sub>	-59.2 – Δ <sub>OTAREFSENS</sub>	-59.2 – Δ <sub>OTAREFSENS</sub>		
	60	G-FR1-A2-6	-59.5 – Δ <sub>OTAREFSENS</sub>	-59.5 – Δ <sub>OTAREFSENS</sub>	-59.5 – Δ <sub>OTAREFSENS</sub>		
35	15	G-FR1-A2-4	-59.2 – Δ <sub>OTAREFSENS</sub>	-59.2 – Δ <sub>OTAREFSENS</sub>	-59.2 – Δ <sub>OTAREFSENS</sub>	-68.7– Δ <sub>OTAREFSENS</sub>	AWGN
	30	G-FR1-A2-5	-59.2 – Δ <sub>OTAREFSENS</sub>	-59.2 – Δ <sub>OTAREFSENS</sub>	-59.2 – Δ <sub>OTAREFSENS</sub>		
	60	G-FR1-A2-6	-59.5 – Δ <sub>OTAREFSENS</sub>	-59.5 – Δ <sub>OTAREFSENS</sub>	-59.5 – Δ <sub>OTAREFSENS</sub>		
40	15	G-FR1-A2-4	-59.2 – Δ <sub>OTAREFSENS</sub>	-59.2 – Δ <sub>OTAREFSENS</sub>	-59.2 – Δ <sub>OTAREFSENS</sub>	-68.1 – Δ <sub>OTAREFSENS</sub>	AWGN
	30	G-FR1-A2-5	-59.2 – Δ <sub>OTAREFSENS</sub>	-59.2 – Δ <sub>OTAREFSENS</sub>	-59.2 – Δ <sub>OTAREFSENS</sub>		
	60	G-FR1-A2-6	-59.5 – Δ <sub>OTAREFSENS</sub>	-59.5 – Δ <sub>OTAREFSENS</sub>	-59.5 – Δ <sub>OTAREFSENS</sub>		
45	15	G-FR1-A2-4	-59.2 – Δ <sub>OTAREFSENS</sub>	-59.2 – Δ <sub>OTAREFSENS</sub>	-59.2 – Δ <sub>OTAREFSENS</sub>	-67.6– Δ <sub>OTAREFSENS</sub>	AWGN
	30	G-FR1-A2-5	-59.2 – Δ <sub>OTAREFSENS</sub>	-59.2 – Δ <sub>OTAREFSENS</sub>	-59.2 – Δ <sub>OTAREFSENS</sub>		
	60	G-FR1-A2-6	-59.5 – Δ <sub>OTAREFSENS</sub>	-59.5 – Δ <sub>OTAREFSENS</sub>	-59.5 – Δ <sub>OTAREFSENS</sub>		
50	15	G-FR1-A2-4	-59.2 – Δ <sub>OTAREFSENS</sub>	-59.2 – Δ <sub>OTAREFSENS</sub>	-59.2 – Δ <sub>OTAREFSENS</sub>	-67.1 – Δ <sub>OTAREFSENS</sub>	AWGN
	30	G-FR1-A2-5	-59.2 – Δ <sub>OTAREFSENS</sub>	-59.2 – Δ <sub>OTAREFSENS</sub>	-59.2 – Δ <sub>OTAREFSENS</sub>		
	60	G-FR1-A2-6	-59.5 – Δ <sub>OTAREFSENS</sub>	-59.5 – Δ <sub>OTAREFSENS</sub>	-59.5 – Δ <sub>OTAREFSENS</sub>		
60	30	G-FR1-A2-5	-59.2 – Δ <sub>OTAREFSENS</sub>	-59.2 – Δ <sub>OTAREFSENS</sub>	-59.2 – Δ <sub>OTAREFSENS</sub>	-66.3 – Δ <sub>OTAREFSENS</sub>	AWGN
	60	G-FR1-A2-6	-59.5 – Δ <sub>OTAREFSENS</sub>	-59.5 – Δ <sub>OTAREFSENS</sub>	-59.5 – Δ <sub>OTAREFSENS</sub>		

70	30	G-FR1-A2-5	-59.2 – $\Delta_{\text{OTAREFSENS}}$	-59.2 – $\Delta_{\text{OTAREFSENS}}$	-59.2 – $\Delta_{\text{OTAREFSENS}}$	-65.7 – $\Delta_{\text{OTAREFSENS}}$	AWGN
	60	G-FR1-A2-6	-59.5 – $\Delta_{\text{OTAREFSENS}}$	-59.5 – $\Delta_{\text{OTAREFSENS}}$	-59.5 – $\Delta_{\text{OTAREFSENS}}$		
80	30	G-FR1-A2-5	-59.2 – $\Delta_{\text{OTAREFSENS}}$	-59.2 – $\Delta_{\text{OTAREFSENS}}$	-59.2 – $\Delta_{\text{OTAREFSENS}}$	-65.1 – $\Delta_{\text{OTAREFSENS}}$	AWGN
	60	G-FR1-A2-6	-59.5 – $\Delta_{\text{OTAREFSENS}}$	-59.5 – $\Delta_{\text{OTAREFSENS}}$	-59.5 – $\Delta_{\text{OTAREFSENS}}$		
90	30	G-FR1-A2-5	-59.2 – $\Delta_{\text{OTAREFSENS}}$	-59.2 – $\Delta_{\text{OTAREFSENS}}$	-59.2 – $\Delta_{\text{OTAREFSENS}}$	-64.5 – $\Delta_{\text{OTAREFSENS}}$	AWGN
	60	G-FR1-A2-6	-59.5 – $\Delta_{\text{OTAREFSENS}}$	-59.5 – $\Delta_{\text{OTAREFSENS}}$	-59.5 – $\Delta_{\text{OTAREFSENS}}$		
100	30	G-FR1-A2-5	-59.2 – $\Delta_{\text{OTAREFSENS}}$	-59.2 – $\Delta_{\text{OTAREFSENS}}$	-59.2 – $\Delta_{\text{OTAREFSENS}}$	-64.1 – $\Delta_{\text{OTAREFSENS}}$	AWGN
	60	G-FR1-A2-6	-59.5 – $\Delta_{\text{OTAREFSENS}}$	-59.5 – $\Delta_{\text{OTAREFSENS}}$	-59.5 – $\Delta_{\text{OTAREFSENS}}$		

NOTE: The wanted signal mean power is the power level of a single instance of the corresponding reference measurement channel. This requirement shall be met for each consecutive application of a single instance of the reference measurement channel mapped to disjoint frequency ranges with a width corresponding to the number of resource blocks of the reference measurement channel each, except for one instance that might overlap one other instance to cover the full *BS channel bandwidth*.

Table 7.4.5.2-2a: Medium Range BS dynamic range for  $6.0 < f \leq 7.125$  GHz

BS channel bandwidth (MHz)	Subcarrier spacing (kHz)	Reference measurement channel (annex A.2)	Wanted signal mean power (dBm)	Interfering signal mean power (dBm) / $BW_{Config}$	Type of interfering signal
20	15	G-FR1-A2-4	-58.2 – $\Delta_{OTAREFSENS}$	-70.2 – $\Delta_{OTAREFSENS}$	AWGN
	30	G-FR1-A2-5	-58.2 – $\Delta_{OTAREFSENS}$		
	60	G-FR1-A2-6	-58.5 – $\Delta_{OTAREFSENS}$		
30	15	G-FR1-A2-4	-58.2 – $\Delta_{OTAREFSENS}$	-68.4 – $\Delta_{OTAREFSENS}$	AWGN
	30	G-FR1-A2-5	-58.2 – $\Delta_{OTAREFSENS}$		
	60	G-FR1-A2-6	-58.5 – $\Delta_{OTAREFSENS}$		
40	15	G-FR1-A2-4	-58.2 – $\Delta_{OTAREFSENS}$	-67.1 – $\Delta_{OTAREFSENS}$	AWGN
	30	G-FR1-A2-5	-58.2 – $\Delta_{OTAREFSENS}$		
	60	G-FR1-A2-6	-58.5 – $\Delta_{OTAREFSENS}$		
50	15	G-FR1-A2-4	-58.2 – $\Delta_{OTAREFSENS}$	-66.1 – $\Delta_{OTAREFSENS}$	AWGN
	30	G-FR1-A2-5	-58.2 – $\Delta_{OTAREFSENS}$		
	60	G-FR1-A2-6	-58.5 – $\Delta_{OTAREFSENS}$		
60	30	G-FR1-A2-5	-58.2 – $\Delta_{OTAREFSENS}$	-65.3 – $\Delta_{OTAREFSENS}$	AWGN
	60	G-FR1-A2-6	-58.5 – $\Delta_{OTAREFSENS}$		
70	30	G-FR1-A2-5	-58.2 – $\Delta_{OTAREFSENS}$	-64.7 – $\Delta_{OTAREFSENS}$	AWGN
	60	G-FR1-A2-6	-58.5 – $\Delta_{OTAREFSENS}$		
80	30	G-FR1-A2-5	-58.2 – $\Delta_{OTAREFSENS}$	-64.1 – $\Delta_{OTAREFSENS}$	AWGN
	60	G-FR1-A2-6	-58.5 – $\Delta_{OTAREFSENS}$		
90	30	G-FR1-A2-5	-58.2 – $\Delta_{OTAREFSENS}$	-63.5 – $\Delta_{OTAREFSENS}$	AWGN
	60	G-FR1-A2-6	-58.5 – $\Delta_{OTAREFSENS}$		
100	30	G-FR1-A2-5	-58.2 – $\Delta_{OTAREFSENS}$	-63.1 – $\Delta_{OTAREFSENS}$	AWGN
	60	G-FR1-A2-6	-58.5 – $\Delta_{OTAREFSENS}$		
<p>NOTE: The wanted signal mean power is the power level of a single instance of the corresponding reference measurement channel. This requirement shall be met for each consecutive application of a single instance of the reference measurement channel mapped to disjoint frequency ranges with a width corresponding to the number of resource blocks of the reference measurement channel each, except for one instance that might overlap one other instance to cover the full <i>BS channel bandwidth</i>.</p>					

**Table 7.4.5.2-3: Local Area BS dynamic range for  $f \leq 6.0$  GHz**

BS channel bandwidth (MHz)	Subcarrier spacing (kHz)	Reference measurement channel (annex A.2)	Wanted signal mean power (dBm)			Interfering signal mean power (dBm) / $BW_{Config}$	Type of interfering signal
			$f \leq 3.0$ GHz	$3.0$ GHz $< f \leq 4.2$ GHz	$4.2$ GHz $< f \leq 6.0$ GHz		
5	15	G-FR1-A2-1	-62.4 – $\Delta_{OTAREFSENS}$	-62.4 – $\Delta_{OTAREFSENS}$	-62.4 – $\Delta_{OTAREFSENS}$	-74.5 – $\Delta_{OTAREFSENS}$	AWGN
	30	G-FR1-A2-2	-64.1 – $\Delta_{OTAREFSENS}$	-64.1 – $\Delta_{OTAREFSENS}$	-64.1 – $\Delta_{OTAREFSENS}$		
10	15	G-FR1-A2-1	-62.4 – $\Delta_{OTAREFSENS}$	-62.4 – $\Delta_{OTAREFSENS}$	-62.4 – $\Delta_{OTAREFSENS}$	-71.3 – $\Delta_{OTAREFSENS}$	AWGN
	30	G-FR1-A2-2	-64.1 – $\Delta_{OTAREFSENS}$	-64.1 – $\Delta_{OTAREFSENS}$	-64.1 – $\Delta_{OTAREFSENS}$		
	60	G-FR1-A2-3	-60.1 – $\Delta_{OTAREFSENS}$	-60.1 – $\Delta_{OTAREFSENS}$	-60.1 – $\Delta_{OTAREFSENS}$		
15	15	G-FR1-A2-1	-62.4 – $\Delta_{OTAREFSENS}$	-62.4 – $\Delta_{OTAREFSENS}$	-62.4 – $\Delta_{OTAREFSENS}$	-69.5 – $\Delta_{OTAREFSENS}$	AWGN
	30	G-FR1-A2-2	-64.1 – $\Delta_{OTAREFSENS}$	-64.1 – $\Delta_{OTAREFSENS}$	-64.1 – $\Delta_{OTAREFSENS}$		
	60	G-FR1-A2-3	-60.1 – $\Delta_{OTAREFSENS}$	-60.1 – $\Delta_{OTAREFSENS}$	-60.1 – $\Delta_{OTAREFSENS}$		
20	15	G-FR1-A2-4	-56.2 – $\Delta_{OTAREFSENS}$	-56.2 – $\Delta_{OTAREFSENS}$	-56.2 – $\Delta_{OTAREFSENS}$	-68.2 – $\Delta_{OTAREFSENS}$	AWGN
	30	G-FR1-A2-5	-56.2 – $\Delta_{OTAREFSENS}$	-56.2 – $\Delta_{OTAREFSENS}$	-56.2 – $\Delta_{OTAREFSENS}$		
	60	G-FR1-A2-6	-56.5 – $\Delta_{OTAREFSENS}$	-56.5 – $\Delta_{OTAREFSENS}$	-56.5 – $\Delta_{OTAREFSENS}$		
25	15	G-FR1-A2-4	-56.2 – $\Delta_{OTAREFSENS}$	-56.2 – $\Delta_{OTAREFSENS}$	-56.2 – $\Delta_{OTAREFSENS}$	-67.2 – $\Delta_{OTAREFSENS}$	AWGN
	30	G-FR1-A2-5	-56.2 – $\Delta_{OTAREFSENS}$	-56.2 – $\Delta_{OTAREFSENS}$	-56.2 – $\Delta_{OTAREFSENS}$		
	60	G-FR1-A2-6	-56.5 – $\Delta_{OTAREFSENS}$	-56.5 – $\Delta_{OTAREFSENS}$	-56.5 – $\Delta_{OTAREFSENS}$		
30	15	G-FR1-A2-4	-56.2 – $\Delta_{OTAREFSENS}$	-56.2 – $\Delta_{OTAREFSENS}$	-56.2 – $\Delta_{OTAREFSENS}$	-66.4 – $\Delta_{OTAREFSENS}$	AWGN
	30	G-FR1-A2-5	-56.2 – $\Delta_{OTAREFSENS}$	-56.2 – $\Delta_{OTAREFSENS}$	-56.2 – $\Delta_{OTAREFSENS}$		
	60	G-FR1-A2-6	-56.5 – $\Delta_{OTAREFSENS}$	-56.5 – $\Delta_{OTAREFSENS}$	-56.5 – $\Delta_{OTAREFSENS}$		
35	15	G-FR1-A2-4	-56.2 – $\Delta_{OTAREFSENS}$	-56.2 – $\Delta_{OTAREFSENS}$	-56.2 – $\Delta_{OTAREFSENS}$	-65.7 – $\Delta_{OTAREFSENS}$	AWGN
	30	G-FR1-A2-5	-56.2 – $\Delta_{OTAREFSENS}$	-56.2 – $\Delta_{OTAREFSENS}$	-56.2 – $\Delta_{OTAREFSENS}$		
	60	G-FR1-A2-6	-56.5 – $\Delta_{OTAREFSENS}$	-56.5 – $\Delta_{OTAREFSENS}$	-56.5 – $\Delta_{OTAREFSENS}$		
40	15	G-FR1-A2-4	-56.2 – $\Delta_{OTAREFSENS}$	-56.2 – $\Delta_{OTAREFSENS}$	-56.2 – $\Delta_{OTAREFSENS}$	-65.1 – $\Delta_{OTAREFSENS}$	AWGN
	30	G-FR1-A2-5	-56.2 – $\Delta_{OTAREFSENS}$	-56.2 – $\Delta_{OTAREFSENS}$	-56.2 – $\Delta_{OTAREFSENS}$		
	60	G-FR1-A2-6	-56.5 – $\Delta_{OTAREFSENS}$	-56.5 – $\Delta_{OTAREFSENS}$	-56.5 – $\Delta_{OTAREFSENS}$		
45	15	G-FR1-A2-4	-56.2 – $\Delta_{OTAREFSENS}$	-56.2 – $\Delta_{OTAREFSENS}$	-56.2 – $\Delta_{OTAREFSENS}$	-64.6 – $\Delta_{OTAREFSENS}$	AWGN
	30	G-FR1-A2-5	-56.2 – $\Delta_{OTAREFSENS}$	-56.2 – $\Delta_{OTAREFSENS}$	-56.2 – $\Delta_{OTAREFSENS}$		
	60	G-FR1-A2-6	-56.5 – $\Delta_{OTAREFSENS}$	-56.5 – $\Delta_{OTAREFSENS}$	-56.5 – $\Delta_{OTAREFSENS}$		
50	15	G-FR1-A2-4	-56.2 – $\Delta_{OTAREFSENS}$	-56.2 – $\Delta_{OTAREFSENS}$	-56.2 – $\Delta_{OTAREFSENS}$	-64.1 – $\Delta_{OTAREFSENS}$	AWGN
	30	G-FR1-A2-5	-56.2 – $\Delta_{OTAREFSENS}$	-56.2 – $\Delta_{OTAREFSENS}$	-56.2 – $\Delta_{OTAREFSENS}$		
	60	G-FR1-A2-6	-56.5 – $\Delta_{OTAREFSENS}$	-56.5 – $\Delta_{OTAREFSENS}$	-56.5 – $\Delta_{OTAREFSENS}$		
60	30	G-FR1-A2-5	-56.2 – $\Delta_{OTAREFSENS}$	-56.2 – $\Delta_{OTAREFSENS}$	-56.2 – $\Delta_{OTAREFSENS}$	-63.3 – $\Delta_{OTAREFSENS}$	AWGN
	60	G-FR1-A2-6	-56.5 – $\Delta_{OTAREFSENS}$	-56.5 – $\Delta_{OTAREFSENS}$	-56.5 – $\Delta_{OTAREFSENS}$		

70	30	G-FR1-A2-5	-56.2 – $\Delta_{\text{OTAREFSENS}}$	-56.2 – $\Delta_{\text{OTAREFSENS}}$	-56.2 – $\Delta_{\text{OTAREFSENS}}$	-62.7 – $\Delta_{\text{OTAREFSENS}}$	AWGN
	60	G-FR1-A2-6	-56.5 – $\Delta_{\text{OTAREFSENS}}$	-56.5 – $\Delta_{\text{OTAREFSENS}}$	-56.5 – $\Delta_{\text{OTAREFSENS}}$		
80	30	G-FR1-A2-5	-56.2 – $\Delta_{\text{OTAREFSENS}}$	-56.2 – $\Delta_{\text{OTAREFSENS}}$	-56.2 – $\Delta_{\text{OTAREFSENS}}$	-62.1 – $\Delta_{\text{OTAREFSENS}}$	AWGN
	60	G-FR1-A2-6	-56.5 – $\Delta_{\text{OTAREFSENS}}$	-56.5 – $\Delta_{\text{OTAREFSENS}}$	-56.5 – $\Delta_{\text{OTAREFSENS}}$		
90	30	G-FR1-A2-5	-56.2 – $\Delta_{\text{OTAREFSENS}}$	-56.2 – $\Delta_{\text{OTAREFSENS}}$	-56.2 – $\Delta_{\text{OTAREFSENS}}$	-61.5 – $\Delta_{\text{OTAREFSENS}}$	AWGN
	60	G-FR1-A2-6	-56.5 – $\Delta_{\text{OTAREFSENS}}$	-56.5 – $\Delta_{\text{OTAREFSENS}}$	-56.5 – $\Delta_{\text{OTAREFSENS}}$		
100	30	G-FR1-A2-5	-56.2 – $\Delta_{\text{OTAREFSENS}}$	-56.2 – $\Delta_{\text{OTAREFSENS}}$	-56.2 – $\Delta_{\text{OTAREFSENS}}$	-61.1 – $\Delta_{\text{OTAREFSENS}}$	AWGN
	60	G-FR1-A2-6	-56.5 – $\Delta_{\text{OTAREFSENS}}$	-56.5 – $\Delta_{\text{OTAREFSENS}}$	-56.5 – $\Delta_{\text{OTAREFSENS}}$		

NOTE: The wanted signal mean power is the power level of a single instance of the corresponding reference measurement channel. This requirement shall be met for each consecutive application of a single instance of the reference measurement channel mapped to disjoint frequency ranges with a width corresponding to the number of resource blocks of the reference measurement channel each, except for one instance that might overlap one other instance to cover the full *BS channel bandwidth*.

Table 7.4.5.2-3a: Local Area BS dynamic range for  $6.0 < f \leq 7.125$  GHz

BS channel bandwidth (MHz)	Subcarrier spacing (kHz)	Reference measurement channel (annex A.2)	Wanted signal mean power (dBm)	Interfering signal mean power (dBm) / $BW_{Config}$	Type of interfering signal
20	15	G-FR1-A2-4	-55.2 – $\Delta_{OTAREFSENS}$	-67.2 – $\Delta_{OTAREFSENS}$	AWGN
	30	G-FR1-A2-5	-55.2 – $\Delta_{OTAREFSENS}$		
	60	G-FR1-A2-6	-55.5 – $\Delta_{OTAREFSENS}$		
30	15	G-FR1-A2-4	-55.2 – $\Delta_{OTAREFSENS}$	-65.4 – $\Delta_{OTAREFSENS}$	AWGN
	30	G-FR1-A2-5	-55.2 – $\Delta_{OTAREFSENS}$		
	60	G-FR1-A2-6	-55.5 – $\Delta_{OTAREFSENS}$		
40	15	G-FR1-A2-4	-55.2 – $\Delta_{OTAREFSENS}$	-64.1 – $\Delta_{OTAREFSENS}$	AWGN
	30	G-FR1-A2-5	-55.2 – $\Delta_{OTAREFSENS}$		
	60	G-FR1-A2-6	-55.5 – $\Delta_{OTAREFSENS}$		
50	15	G-FR1-A2-4	-55.2 – $\Delta_{OTAREFSENS}$	-63.1 – $\Delta_{OTAREFSENS}$	AWGN
	30	G-FR1-A2-5	-55.2 – $\Delta_{OTAREFSENS}$		
	60	G-FR1-A2-6	-55.5 – $\Delta_{OTAREFSENS}$		
60	30	G-FR1-A2-5	-55.2 – $\Delta_{OTAREFSENS}$	-62.3 – $\Delta_{OTAREFSENS}$	AWGN
	60	G-FR1-A2-6	-55.5 – $\Delta_{OTAREFSENS}$		
70	30	G-FR1-A2-5	-55.2 – $\Delta_{OTAREFSENS}$	-61.7 – $\Delta_{OTAREFSENS}$	AWGN
	60	G-FR1-A2-6	-55.5 – $\Delta_{OTAREFSENS}$		
80	30	G-FR1-A2-5	-55.2 – $\Delta_{OTAREFSENS}$	-61.1 – $\Delta_{OTAREFSENS}$	AWGN
	60	G-FR1-A2-6	-55.5 – $\Delta_{OTAREFSENS}$		
90	30	G-FR1-A2-5	-55.2 – $\Delta_{OTAREFSENS}$	-60.5 – $\Delta_{OTAREFSENS}$	AWGN
	60	G-FR1-A2-6	-55.5 – $\Delta_{OTAREFSENS}$		
100	30	G-FR1-A2-5	-55.2 – $\Delta_{OTAREFSENS}$	-60.1 – $\Delta_{OTAREFSENS}$	AWGN
	60	G-FR1-A2-6	-55.5 – $\Delta_{OTAREFSENS}$		
<p>NOTE: The wanted signal mean power is the power level of a single instance of the corresponding reference measurement channel. This requirement shall be met for each consecutive application of a single instance of the reference measurement channel mapped to disjoint frequency ranges with a width corresponding to the number of resource blocks of the reference measurement channel each, except for one instance that might overlap one other instance to cover the full <i>BS channel bandwidth</i>.</p>					

## 7.5 OTA in-band selectivity and blocking

### 7.5.1 OTA adjacent channel selectivity

#### 7.5.1.1 Definition and applicability

OTA Adjacent channel selectivity (ACS) is a measure of the receiver's ability to receive an OTA wanted signal at its assigned channel frequency in the presence of an OTA adjacent channel signal with a specified centre frequency offset of the interfering signal to the band edge of a victim system. The wanted and interfering signals apply to each supported polarization, under the assumption of polarization match.

#### 7.5.1.2 Minimum requirement

For *BS type 1-O*, the minimum requirement is in TS 38.104 [2], clause 10.5.1.2.

For *BS type 2-O*, the minimum requirement is in TS 38.104 [2], clause 10.5.1.3.

#### 7.5.1.3 Test purpose

The test purpose is to verify the ability of the BS receiver filter to suppress interfering signals in the channels adjacent to the wanted channel.

#### 7.5.1.4 Method of test

##### 7.5.1.4.1 Initial conditions

Test environment: Normal, see annex B.2.

RF channels to be tested for single carrier:

- M; see clause 4.9.1.

*Base Station RF Bandwidth* edge position to be tested for multi-carrier and/or CA:

- $M_{\text{RFBW}}$  in single-band operation, see clause 4.9.1;
- $B'_{\text{RFBW}}T'_{\text{RFBW}}$  and  $B'_{\text{RFBW}}T_{\text{RFBW}}$  in multi-band operation, see clause 4.9.1.

Directions to be tested:

- For BS type 1-O, receiver target reference direction (D.31),
- For BS type 2-O, OTA REFSENS receiver target reference direction (D.54).

##### 7.5.1.4.2 Procedure

- 1) Place the BS with its manufacturer declared coordinate system reference point in the same place as calibrated point in the test system, as shown in annex E.2.3.
- 2) Align the manufacturer declared coordinate system orientation of the BS with the test system.
- 3) Align the BS with the test antenna in the declared direction to be tested.
- 4) Align the BS so that the wanted signal and interferer signal is *polarization matched* with the test antenna(s).
- 5) Configure the beam peak direction for the transmitter according to the declared reference beam direction pair for the appropriate beam identifier.
- 6) For FDD operation, set the BS to transmit beam(s) of the same operational band as the OSDD or *OTA REFSENS RoAoA* being tested according to the appropriate test configuration in clauses 4.7 and 4.8.



- 7) Set the test signal mean power so that the calibrated radiated power at the BS Antenna Array coordinate system reference point is as follows:
  - a) Set the signal generator for the wanted signal to transmit as specified in table 7.5.1.4.1-1 for *BS type 1-O* and table 7.5.1.4.2-1 for *BS type 2-O*.
  - b) Set the signal generator for the interfering signal at the adjacent channel frequency of the wanted signal to transmit as specified in table 7.5.1.4.1-1 for *BS type 1-O* and table 7.5.1.4.2-1 for *BS type 2-O*.
- 8) Measure throughput according to annex A.1 for each supported polarization, for multi-carrier and/or CA operation the throughput shall be measured for relevant carriers specified by the test configuration specified in clauses 4.7.2 and 4.8.

For *multi-band RIB(s)* and single band tests, repeat the steps above per involved band where single band test configurations and test models shall apply with no carriers activated in the other band.

### 7.5.1.5 Test requirement

#### 7.5.1.5.1 General

The test requirement is calculated from the OTA wanted signal mean power level offset by the OTA ACS Test Tolerance specified in clause 4.1.

#### 7.5.1.5.2 Test requirements for *BS type 1-O*

The requirement shall apply at the RIB when the AoA of the incident wave of a received signal and the interfering signal are from the same direction, and the AoA of the incident wave of a received signal and the interfering signal are within the *minSENS RoAoA*.

The wanted and interfering signals apply to each supported polarization, under the assumption of *polarization match*.

The throughput shall be  $\geq 95\%$  of the maximum throughput of the reference measurement channel.

For FR1, the OTA wanted and the interfering signal are specified in table 7.5.1.5.2-1, 7.5.1.5.2-1a and table 7.5.1.5.2-2 for ACS. The reference measurement channel for the OTA wanted signal is identified in clause 7.3.5.2 and is further specified in annex A.1. The characteristics of the interfering signal is further specified in TS 38.104 [2] annex D.

The OTA ACS requirement is applicable outside the Base Station RF Bandwidth or Radio Bandwidth. The OTA interfering signal offset is defined relative to the Base station RF Bandwidth edges or Radio Bandwidth edges.

For RIBs supporting operation in *non-contiguous spectrum* within any operating band, the OTA ACS requirement shall apply in addition inside any sub-block gap, in case the sub-block gap size is at least as wide as the NR interfering signal in table 7.5.1.5.2-2. The OTA interfering signal offset is defined relative to the sub-block edges inside the sub-block gap.

For *multi-band RIBs*, the OTA ACS requirement shall apply in addition inside any Inter RF Bandwidth gap, in case the Inter RF Bandwidth gap size is at least as wide as the NR interfering signal in table 7.5.1.5.2-2. The interfering signal offset is defined relative to the Base Station RF Bandwidth edges inside the Inter RF Bandwidth gap.

**Table 7.5.1.5.2-1: OTA ACS requirement for *BS type 1-O* for  $f \leq 6.0$  GHz**

<b><i>BS channel bandwidth of the lowest/highest carrier received (MHz)</i></b>	<b>Wanted signal mean power (dBm)</b> <b>(Note 2)</b>			<b>Interfering signal mean power (dBm)</b>
	<b><math>f \leq 3.0</math> GHz</b>	<b><math>3.0 \text{ GHz} &lt; f \leq 4.2 \text{ GHz}</math></b>	<b><math>4.2 \text{ GHz} &lt; f \leq 6.0 \text{ GHz}</math></b>	
5, 10, 15, 20, 25, 30, 35, 40, 45, 50, 60, 70, 80, 90, 100 (Note 1)	$EIS_{\min\text{SENS}} + 6 \text{ dB}$			Wide Area BS: $-52 - \Delta_{\min\text{SENS}}$ Medium Range BS: $-47 - \Delta_{\min\text{SENS}}$ Local Area BS: $-44 - \Delta_{\min\text{SENS}}$
NOTE 1: The SCS for the lowest/highest carrier received is the lowest SCS supported by the BS for that bandwidth. NOTE 2: $EIS_{\min\text{SENS}}$ depends on the <i>BS channel bandwidth</i> as specified in TS 38.104 [2], clause 10.2.1.				

Table 7.5.1.5.2-1a: OTA ACS requirement for *BS type 1-O* for band 6.0 GHz <  $f \leq 7.125$  GHz

<b>BS channel bandwidth of the lowest/highest carrier received (MHz)</b>	<b>Wanted signal mean power (dBm) (Note 2)</b>	<b>Interfering signal mean power (dBm)</b>
20, 30, 40, 50, 60, 70, 80, 90, 100 (Note 1)	$EIS_{\min\text{SENS}} + 6$ dB	Wide Area BS: $-55 - \Delta_{\min\text{SENS}}$ Medium Range BS: $-50 - \Delta_{\min\text{SENS}}$ Local Area BS: $-47 - \Delta_{\min\text{SENS}}$
NOTE 1: The SCS for the lowest/highest carrier received is the lowest SCS supported by the BS for that bandwidth. NOTE 2: $EIS_{\min\text{SENS}}$ depends on the <i>BS channel bandwidth</i> as specified in TS 38.104 [2], clause 10.2.1.		

Table 7.5.1.5.2-2: OTA ACS interferer frequency offset for *BS type 1-O*

<b>BS channel bandwidth of the lowest/highest carrier received (MHz)</b>	<b>Interfering signal centre frequency offset from the lower/upper Base Station RF Bandwidth edge or sub-block edge inside a sub-block gap (MHz)</b>	<b>Type of interfering signal</b>
5	$\pm 2.5025$	5 MHz DFT-s-OFDM NR signal, 15 kHz SCS, 25 RBs
10	$\pm 2.5075$	
15	$\pm 2.5125$	
20	$\pm 2.5025$	
25	$\pm 9.4675$	20 MHz DFT-s-OFDM NR signal, 15 kHz SCS, 100 RBs
30	$\pm 9.4725$	
35	$\pm 9.4625$	
40	$\pm 9.4675$	
45	$\pm 9.4725$	
50	$\pm 9.4625$	
60	$\pm 9.4725$	
70	$\pm 9.4675$	
80	$\pm 9.4625$	
90	$\pm 9.4725$	
100	$\pm 9.4675$	

### 7.5.1.5.3 Test requirements for *BS type 2-O*

The requirement shall apply at the RIB when the AoA of the incident wave of a received signal and the interfering signal are from the same direction and are within the *OTA REFSENS RoAoA*.

The wanted and interfering signals apply to each supported polarization, under the assumption of *polarization match*.

The throughput shall be  $\geq 95\%$  of the maximum throughput of the reference measurement channel.

For FR2, the OTA wanted and the interfering signal are specified in table 7.5.1.5.3-1 and table 7.5.1.5.3-2 for ACS. The reference measurement channel for the OTA wanted signal is identified in clause 7.3.5.3 and is further specified in annex A.1. The characteristics of the interfering signal is further specified in TS 38.104 [2] annex D.

The OTA ACS requirement is applicable outside the Base Station RF Bandwidth. The OTA interfering signal offset is defined relative to the Base station RF Bandwidth edges.

For RIBs supporting operation in *non-contiguous spectrum* within any *operating band*, the OTA ACS requirement shall apply in addition inside any sub-block gap, in case the sub-block gap size is at least as wide as the NR interfering signal in table 7.5.1.5.3-2. The OTA interfering signal offset is defined relative to the sub-block edges inside the sub-block gap.

Table 7.5.1.5.3-1: OTA ACS requirement for *BS type 2-O*

Frequency range	BS channel bandwidth of the lowest/highest carrier received (MHz)	Wanted signal mean power (dBm)	Interfering signal mean power (dBm)
FR2-1	50, 100, 200, 400	EIS <sub>REFSENS</sub> + 6 dB (Note 3)	EIS <sub>REFSENS_50M</sub> + 27.7 + Δ <sub>FR2_REFSENS</sub> (Note 1)
			EIS <sub>REFSENS_50M</sub> + 26.7 + Δ <sub>FR2_REFSENS</sub> (Note 2)
FR2-2	100, 400, 800, 1600, 2000		EIS <sub>REFSENS_50M</sub> + 28.7 + Δ <sub>FR2_REFSENS</sub> (Note 4)
NOTE 1: Applicable to bands defined within the frequency spectrum range of 24.25 – 33.4 GHz.			
NOTE 2: Applicable to bands defined within the frequency spectrum range of 37 – 52.6 GHz.			
NOTE 3: EIS <sub>REFSENS</sub> is specified in TS 38.104 [2], clause 10.3.3.			
NOTE 4: Applicable to bands defined within the frequency spectrum range of 52.6 – 71 GHz.			

Table 7.5.1.5.3-2: OTA ACS interferer frequency offset for *BS type 2-O*

Frequency range	BS channel bandwidth of the lowest/highest carrier received (MHz)	Interfering signal centre frequency offset from the lower/upper Base Station RF Bandwidth edge or sub-block edge inside a sub-block gap (MHz)	Type of interfering signal
FR2-1	50	±24.29	50 MHz DFT-s-OFDM NR signal, 60 kHz SCS, 64 RBs
	100	±24.31	
	200	±24.29	
	400	±24.31	
FR2-2	100	±48.58	100 MHz DFT-s-OFDM NR signal, 120 kHz SCS, 64 RBs
	400	±48.58	
	800	±48.62	
	1600	±48.58	
	2000	±48.62	

## 7.5.2 OTA in-band blocking

### 7.5.2.1 Definition and applicability

The OTA in-band blocking characteristics is a measure of the receiver's ability to receive a OTA wanted signal at its assigned channel in the presence of an unwanted OTA interferer, which is an NR signal for general blocking or an NR signal with one RB for narrowband blocking.

### 7.5.2.2 Minimum requirement

For *BS type 1-O*, the minimum requirement is in TS 38.104 [2], clause 10.5.2.2.

For *BS type 2-O*, the minimum requirement is in TS 38.104 [2], clause 10.5.2.3.

### 7.5.2.3 Test purpose

The test purpose is to verify the ability of the BS receiver to withstand high-levels of in-band interference from unwanted signals at specified frequency offsets without undue degradation of its sensitivity.

### 7.5.2.4 Method of test

#### 7.5.2.4.1 Initial conditions

Test environment: Normal, see annex B.2.

RF channels to be tested for single carrier:M; see clause 4.9.1.

*Base Station RF Bandwidth* edge position to be tested for multi-carrier and/or CA:

- $M_{\text{RFBW}}$  in single-band operation, see clause 4.9.1;
- $B_{\text{RFBW}_T}$  and  $B'_{\text{RFBW}_T}$  in multi-band operation, see clause 4.9.1.

Directions to be tested:

For BS type 1-O:

- receiver target reference direction for the minSENS OSDD (D.31),
- OTA REFSSENS conformance test directions (D.55),

For BS type 2-O:

- OTA REFSSENS receiver target reference direction (D.54),
- OTA REFSSENS conformance test directions (D.55).

#### 7.5.2.4.2 Procedure

- 1) Place the BS with its manufacturer declared coordinate system reference point in the same place as calibrated point in the test system, as shown in annex E.2.3.
- 2) Align the manufacturer declared coordinate system orientation of the BS with the test system.
- 3) Align the BS with the test antenna in the declared direction to be tested.
- 4) Align the BS so that the wanted signal and interferer signal is *polarization matched* with the test antenna(s).
- 5) Configure the beam peak direction for the transmitter according to the declared reference beam direction pair for the appropriate beam identifier.
- 6) For FDD operation, set the BS to transmit beam(s) of the same operational band as the OSDD or *OTA REFSSENS RoAoA* being tested according to the appropriate test configuration in clauses 4.7 and 4.8.
- 7) Set the test signal mean power so that the calibrated radiated power at the BS Antenna Array coordinate system reference point is as follows:

For general OTA blocking:

- a) Set the signal generator for the wanted signal to transmit as specified in table 7.5.2.5.2-1 for *BS type 1-O* and table 7.5.2.5.3-1 for *BS type 2-O*.
- b) Set the signal generator for the interfering signal at the specified frequency offset from the wanted signal to transmit as specified in table 7.5.2.5.2-1 for *BS type 1-O* and table 7.5.2.5.3-1 for *BS type 2-O*. The interfering signal shall be swept with a step size of 1 MHz for *BS type 1-O* or as indicated in Table 7.5.2.4.2-1 for *BS type 2-O* starting from the minimum offset to the channel edges of the wanted signals.

**Table 7.5.2.4.2-1: FR2 Interferer signal step size**

Minimum supported <i>BS channel bandwidth</i> (MHz)	Measurement step size (MHz)
50	15
100	30
200	60
400	60

For OTA narrowband blocking:

- a) Set the signal generator for the wanted signal to transmit as specified in table 7.5.2.5.2-2 for *BS type 1-O*.

- b) Set the signal generator for the interfering signal at the specified frequency offset from the wanted signal to transmit as specified in tables 7.5.2.5.2-2 and 7.5.2.5.2-3 for *BS type 1-O*. Set-up and sweep the interfering RB centre frequency offset to the channel edge of the wanted signal according to table 7.5.2.5.2-3.
- 8) Measure throughput according to annex A.1 for each supported polarization, for multi-carrier and/or CA operation the throughput shall be measured for relevant carriers specified by the test configuration specified in clauses 4.7.2 and 4.8.
- 9) Repeat steps 3 to 8 for all the specified measurement directions.

For *multi-band RIB(s)* and single band tests, repeat the steps above per involved band where single band test configurations and test models shall apply with no carriers activated in the other band.

## 7.5.2.5 Test requirement

### 7.5.2.5.1 General

The test requirement is calculated from the OTA wanted signal mean power level offset by the OTA in-band blocking Test Tolerance specified in clause 4.1.

### 7.5.2.5.2 Test requirements for *BS type 1-O*

The requirement shall apply at the RIB when the AoA of the incident wave of a received signal and the interfering signal are from the same direction, and:

- when the wanted signal is based on  $EIS_{REFSENS}$ : the AoA of the incident wave of a received signal and the interfering signal are within the *OTA REFSENS RoAoA*.
- when the wanted signal is based on  $EIS_{minSENS}$ : the AoA of the incident wave of a received signal and the interfering signal are within the *minSENS RoAoA*.

The wanted and interfering signals apply to each supported polarization, under the assumption of *polarization match*.

The throughput shall be  $\geq 95\%$  of the maximum throughput of the reference measurement channel, with OTA wanted and OTA interfering signal specified in tables 7.5.2.5.2-1, table 7.5.2.5.2-2 and table 7.5.2.5.2-3 for general OTA and narrowband OTA blocking requirements. Narrowband blocking requirements shall not be applied for band n104. The reference measurement channel for the OTA wanted signal is identified in clause 7.3.5.2 and is further specified in annex A.1. The characteristics of the interfering signal is further specified in TS 38.104 [2] annex D.

The OTA in-band blocking requirements apply outside the *Base Station RF Bandwidth* or *Radio Bandwidth*. The interfering signal offset is defined relative to the *Base Station RF Bandwidth edges* or *Radio Bandwidth edges*.

For *BS type 1-O* the OTA in-band blocking requirement shall apply in the in-band blocking frequency range, which is defined within frequency range from  $F_{UL\_low} - \Delta f_{OOB}$  to  $F_{UL\_high} + \Delta f_{OOB}$ , excluding the downlink frequency range of the *FDD operating band*, where the  $\Delta f_{OOB}$  for *BS type 1-O* is defined in table 7.5.2.5.2-0.

**Table 7.5.2.5.2-0:  $\Delta f_{OOB}$  offset for NR operating bands in FR1**

BS type	Operating band characteristics	$\Delta f_{OOB}$ (MHz)
BS type 1-O	$F_{UL\_high} - F_{UL\_low} < 100$ MHz	20
	$100$ MHz $\leq F_{UL\_high} - F_{UL\_low} \leq 900$ MHz	60
	n104	100

For RIBs supporting operation in *non-contiguous spectrum* within any *operating band*, the OTA in-band blocking requirements apply in addition inside any sub-block gap, in case the sub-block gap size is at least as wide as twice the interfering signal minimum offset in table 7.5.2.5.2-1. The interfering signal offset is defined relative to the sub-block edges inside the sub-block gap.

For *multi-band RIBs*, the OTA in-band blocking requirements apply in the in-band blocking frequency ranges for each supported *operating band*. The requirement shall apply in addition inside any *Inter RF Bandwidth gap*, in case the *Inter RF Bandwidth gap* size is at least as wide as twice the interfering signal minimum offset in tables 7.5.2.5.2-1 and 7.5.2.5.2-3.

For a RIBs supporting operation in *non-contiguous spectrum* within any operating band, the OTA narrowband blocking requirements apply in addition inside any sub-block gap, in case the sub-block gap size is at least as wide as the interfering signal minimum offset in table 7.5.2.5.2-3. The interfering signal offset is defined relative to the sub-block edges inside the sub-block gap.

For a *multi-band RIBs*, the OTA narrowband blocking requirements apply in the narrowband blocking frequency ranges for each supported *operating band*. The requirement shall apply in addition inside any *Inter RF Bandwidth gap*, in case the *Inter RF Bandwidth gap* size is at least as wide as the interfering signal minimum offset in table 7.5.2.5.2-3.

**Table 7.5.2.5.2-1: General OTA blocking requirement for BS type 1-0**

BS channel bandwidth of the lowest/highest carrier received (MHz)	Wanted signal mean power (dBm)			Interfering signal mean power (dBm)	Interfering signal centre frequency minimum offset from the lower/upper Base Station RF Bandwidth edge or sub-block edge inside a sub-block gap (MHz)	Type of interfering signal
	$f \leq 3.0$ GHz	3.0 GHz < $f \leq 4.2$ GHz	4.2 GHz < $f \leq 7.125$ GHz			
5, 10, 15, 20	EIS <sub>REFSENS</sub> + X dB (NOTE 2, NOTE 4)			Wide Area BS: -43 - $\Delta_{OTAREFSENS}$ Medium Range BS: -38 - $\Delta_{OTAREFSENS}$ Local Area BS: -35 - $\Delta_{OTAREFSENS}$ (NOTE 2)	$\pm 7.5$	5 MHz DFT-s-OFDM NR signal, 15 kHz SCS, 25 RBs
	EIS <sub>minSENS</sub> + X dB (NOTE 3, NOTE 4)			Wide Area BS: -43 - $\Delta_{minSENS}$ Medium Range BS: -38 - $\Delta_{minSENS}$ Local Area BS: -35 - $\Delta_{minSENS}$ (NOTE 3)		
25, 30, 35, 40, 45, 50, 60, 70, 80, 90, 100	EIS <sub>REFSENS</sub> + X dB (NOTE 2, NOTE 4)			Wide Area BS: -43 - $\Delta_{OTAREFSENS}$ Medium Range BS: -38 - $\Delta_{OTAREFSENS}$ Local Area BS: -35 - $\Delta_{OTAREFSENS}$ (NOTE 2)	$\pm 30$	20 MHz DFT-s-OFDM NR signal, 15 kHz SCS, 100 RBs
	EIS <sub>minSENS</sub> + X dB (NOTE 3, NOTE 4)			Wide Area BS: -43 - $\Delta_{minSENS}$ Medium Range BS: -38 - $\Delta_{minSENS}$ Local Area BS: -35 - $\Delta_{minSENS}$ (NOTE 3)		

NOTE 1: EIS<sub>REFSENS</sub> and EIS<sub>minSENS</sub> depends on the BS channel bandwidth as specified in TS 38.104 [2], clause 10.3.2 and 10.2.1.

NOTE 2: This test requirement is only applied in the OTA REFSENS conformance test directions.

NOTE 3: This test requirement is only applied in the OTA minSENS receiver target reference direction.

NOTE 4: For a BS capable of single band operation only, "x" is equal to 6 dB. For a BS capable of multi-band operation, "x" is equal to 6 dB in case of interfering signals that are in the in-band blocking frequency range of the operating band where the wanted signal is present or in the in-band blocking frequency range of an adjacent or overlapping operating band. For other in-band blocking frequency ranges of the interfering signal for the supported operating bands, "x" is equal to 1.4 dB.

Table 7.5.2.5.2-2: OTA narrowband blocking requirement for *BS type 1-O*

<i>BS channel bandwidth</i> of the lowest/highest carrier received (MHz)	OTA Wanted signal mean power (dBm)			OTA Interfering signal mean power (dBm)
	$f \leq 3.0$ GHz	$3.0 \text{ GHz} < f \leq 4.2 \text{ GHz}$	$4.2 \text{ GHz} < f \leq 6.0 \text{ GHz}$	
5, 10, 15, 20	EIS <sub>REFSENS</sub> + 6 dB (NOTE 3)			Wide Area BS: -49 - $\Delta_{\text{OTAREFSENS}}$ Medium Range BS: -44 - $\Delta_{\text{OTAREFSENS}}$ Local Area BS: -41 - $\Delta_{\text{OTAREFSENS}}$
	EIS <sub>minSENS</sub> + 6 dB (NOTE 4)			Wide Area BS: -49 - $\Delta_{\text{minSENS}}$ Medium Range BS: -44 - $\Delta_{\text{minSENS}}$ Local Area BS: -41 - $\Delta_{\text{minSENS}}$
25, 30, 35, 40, 45, 50, 60, 70, 80, 90, 100	EIS <sub>REFSENS</sub> + 6 dB (NOTE 3)			Wide Area BS: -49 - $\Delta_{\text{OTAREFSENS}}$ Medium Range BS: -44 - $\Delta_{\text{OTAREFSENS}}$ Local Area BS: -41 - $\Delta_{\text{OTAREFSENS}}$
	EIS <sub>minSENS</sub> + 6 dB (NOTE 4)			Wide Area BS: -49 - $\Delta_{\text{minSENS}}$ Medium Range BS: -44 - $\Delta_{\text{minSENS}}$ Local Area BS: -41 - $\Delta_{\text{minSENS}}$
NOTE 1: The SCS for the lowest/highest carrier received is the lowest SCS supported by the BS for that bandwidth.				
NOTE 2: EIS <sub>REFSENS</sub> and EIS <sub>minSENS</sub> depends on the <i>BS channel bandwidth</i> as specified in TS 38.104 [2], clause 10.3.2 and 10.2.1.				
NOTE 3: This test requirement is only applied in the OTA REFSENS conformance test directions.				
NOTE 4: This test requirement is only applied in the OTA minSENS receiver target reference direction.				
NOTE 5: 7.5 kHz shift is not applied to the wanted signal.				

Table 7.5.2.5.2-3: OTA narrowband blocking interferer frequency offsets for *BS type 1-O*

<i>BS channel bandwidth</i> of the lowest/highest carrier received (MHz)	Interfering RB centre frequency offset to the lower/upper Base Station RF Bandwidth edge or sub-block edge inside a sub-block gap (kHz) (Note 2)	Type of interfering signal	
5	$\pm(350 + m \cdot 180)$ , m=0, 1, 2, 3, 4, 9, 14, 19, 24	5 MHz DFT-s-OFDM NR signal, 15 kHz SCS, 1 RB	
10	$\pm(355 + m \cdot 180)$ , m=0, 1, 2, 3, 4, 9, 14, 19, 24		
15	$\pm(360 + m \cdot 180)$ , m=0, 1, 2, 3, 4, 9, 14, 19, 24		
20	$\pm(350 + m \cdot 180)$ , m=0, 1, 2, 3, 4, 9, 14, 19, 24		
25	$\pm(565 + m \cdot 180)$ , m=0, 1, 2, 3, 4, 29, 54, 79, 99	20 MHz DFT-s-OFDM NR signal, 15 kHz SCS, 1 RB	
30	$\pm(570 + m \cdot 180)$ , m=0, 1, 2, 3, 4, 29, 54, 79, 99		
35	$\pm(560 + m \cdot 180)$ , m=0, 1, 2, 3, 4, 29, 54, 79, 99		
40	$\pm(565 + m \cdot 180)$ , m=0, 1, 2, 3, 4, 29, 54, 79, 99		
45	$\pm(570 + m \cdot 180)$ , m=0, 1, 2, 3, 4, 29, 54, 79, 99		
50	$\pm(560 + m \cdot 180)$ , m=0, 1, 2, 3, 4, 29, 54, 79, 99		
60	$\pm(570 + m \cdot 180)$ , m=0, 1, 2, 3, 4, 29, 54, 79, 99		
70	$\pm(565 + m \cdot 180)$ , m=0, 1, 2, 3, 4, 29, 54, 79, 99		
80	$\pm(560 + m \cdot 180)$ , m=0, 1, 2, 3, 4, 29, 54, 79, 99		
90	$\pm(570 + m \cdot 180)$ , m=0, 1, 2, 3, 4, 29, 54, 79, 99		
100	$\pm(565 + m \cdot 180)$ , m=0, 1, 2, 3, 4, 29, 54, 79, 99		
NOTE 1: Interfering signal consisting of one resource block is positioned at the stated offset, the channel bandwidth of the interfering signal is located adjacently to the lower/upper Base Station RF Bandwidth edge.			
NOTE 2: The centre of the interfering RB refers to the frequency location between the two central subcarriers.			

### 7.5.2.5.3 Test requirements for *BS type 2-O*

The requirement shall apply at the RIB when the AoA of the incident wave of a received signal and the interfering signal are from the same direction and are within the *OTA REFSENS RoAoA*.

The wanted and interfering signals apply to each supported polarization, under the assumption of *polarization match*.

The throughput shall be  $\geq 95\%$  of the maximum throughput of the reference measurement channel.

For *BS type 2-O*, the OTA wanted and OTA interfering signals are provided at RIB using the parameters in table 7.5.2.5.3-1 for general OTA blocking requirements. The reference measurement channel for the OTA wanted signal is identified in clause 7.3.5.3 and is further specified in annex A.1. The characteristics of the interfering signal is further specified in TS 38.104 [2] annex D.

The OTA blocking requirements are applicable outside the *Base Station RF Bandwidth*. The interfering signal offset is defined relative to the *Base Station RF Bandwidth edges*.

For *BS type 2-O* the OTA blocking requirement shall apply in the in-band blocking frequency range, which is defined within frequency range from  $F_{UL\_low} - \Delta f_{OOB}$  to  $F_{UL\_high} + \Delta f_{OOB}$ , where the  $\Delta f_{OOB}$  for *BS type 2-O* is defined in table 7.5.2.5.3-0.



Table 7.5.2.5.3-0:  $\Delta f_{\text{OOB}}$  offset for NR operating bands in FR2

BS type	Frequency range	Operating band characteristics (MHz)	$\Delta f_{\text{OOB}}$ (MHz)
BS type 2-O	FR2-1	$F_{\text{UL\_high}} - F_{\text{UL\_low}} \leq 4000$	1500
	FR2-2	$4000 < F_{\text{UL\_high}} - F_{\text{UL\_low}} \leq 14000$	3500

For a RIBs supporting operation in *non-contiguous spectrum* within any *operating band*, the OTA blocking requirements apply in addition inside any sub-block gap, in case the sub-block gap size is at least as wide as twice the interfering signal minimum offset in table 7.5.2.5.3-1. The interfering signal offset is defined relative to the sub-block edges inside the sub-block gap.

Table 7.5.2.5.3-1: General OTA blocking requirement for BS type 2-O

Frequency range	BS channel bandwidth of the lowest/highest carrier received (MHz)	OTA wanted signal mean power (dBm)	OTA interfering signal mean power (dBm)	OTA interfering signal centre frequency offset from the lower/upper Base Station RF Bandwidth edge or sub-block edge inside a sub-block gap (MHz)	Type of OTA interfering signal
FR2-1	50, 100, 200, 400	$EIS_{\text{REFSENS}} + 6$ dB	$EIS_{\text{REFSENS\_50M}} + 33 + \Delta_{\text{FR2\_REFSENS}}$ dB	$\pm 75$	50 MHz DFT-s-OFDM NR signal, 60 kHz SCS, 64 RBs
FR2-2	100, 400, 800, 1600, 2000		$EIS_{\text{REFSENS\_50M}} + 36 + \Delta_{\text{FR2\_REFSENS}}$	$\pm 150$	100 MHz DFT-s-OFDM NR signal, 120 kHz SCS, 64 RBs
NOTE: $EIS_{\text{REFSENS}}$ and $EIS_{\text{REFSENS\_50M}}$ are given in TS 38.104 [2], clause 10.3.3.					

## 7.6 OTA out-of-band blocking

### 7.6.1 Definition and applicability

The OTA out-of-band blocking characteristics are a measure of the receiver unit ability to receive a wanted signal at the RIB at its assigned channel in the presence of an unwanted interferer.

For the general OTA out-of-band blocking the requirement applies to the wanted signal for each supported polarization, under the assumption of *polarization match*. The interferer shall be polarization matched for in-band frequencies and the polarization maintained for out-of-band frequencies.

### 7.6.2 Minimum requirement

The minimum requirement for BS type 1-O is defined in TS 38.104 [2], clause 10.6.2.

The minimum requirement for BS type 2-O is defined in TS 38.104 [2], clause 10.6.3.

### 7.6.3 Test purpose

The test stresses the ability of the receiver unit associated with the RIB under test to withstand high-level interference from unwanted signals at specified frequency bands, without undue degradation of its sensitivity.

## 7.6.4 Method of test

### 7.6.4.1 Initial conditions

Test environment: Normal; see annex B.2.

RF channels to be tested for single carrier (SC): M; see clause 4.9.1.

*Base Station RF Bandwidth* positions to be tested for multi-carrier (MC):

- $M_{\text{RFBW}}$  in *single-band RIB*, see clause 4.9.1;  $B_{\text{RFBW\_T'RFBW}}$  and  $B'_{\text{RFBW\_T'RFBW}}$  in *multi-band RIB*, see clause 4.9.1.

In addition, for *multi-band RIB*:

- For  $B_{\text{RFBW\_T'RFBW}}$ , blocking testing above the highest operating band may be omitted.
- For  $B'_{\text{RFBW\_T'RFBW}}$ , blocking testing below the lowest operating band may be omitted.

Directions to be tested:

- For *BS type 1-O*, receiver target reference direction (D.31).
- For *BS type 2-O*, OTA REFSSENS receiver target reference direction (D.54).

### 7.6.4.2 Procedure

#### 7.6.4.2.1 *BS type 1-O* procedure for out-of-band blocking

- 1) Place BS and the test antenna(s) according to annex E.2.4.1.
- 2) Align the BS and test antenna(s) according to the directions to be tested.
- 3) Connect test antenna(s) to the measurement equipment as shown in annex E.2.4.1.
- 4) The test antenna(s) shall be dual (or single) polarized covering the same frequency ranges as the *BS* and the blocking frequencies. If the test antenna does not cover both the wanted and interfering signal frequencies, separate test antennas for the wanted and interfering signal are required.
- 5) The OTA blocking interferer is injected into the test antenna, with the blocking interferer producing specified interferer field strength level for each supported polarization. The interferer shall be *polarization matched* in-band and the polarization maintained for out-of-band frequencies.
- 6) Generate the wanted signal in receiver target reference direction, according to the applicable test configuration (see clause 4.8) using applicable reference measurement channel to the RIB, according to annex A.1.
- 7) For FDD operation, configure the beam peak direction for the transmitter units associated with the RIB under test according to the declared reference beam direction pair for the appropriate beam identifier with the carrier set-up and power allocation according to the applicable test configuration(s) (see clause 4.8). The transmitter may be turned OFF for the out-of-band blocker tests when the frequency of the blocker is such that no IM2 or IM3 products fall inside the bandwidth of the wanted signal.
- 8) Adjust the signal generators to the type of interfering signals, levels and the frequency offsets as specified for general test requirements in table 7.6.5.1.1-1. The distance between the test object and test antenna injecting the interferer signal is adjusted when necessary to ensure specified interferer signal level to be received.
- 9) The CW interfering signal shall be swept with a step size of 1 MHz within the frequency range specified in clause 7.6.5.1.1.
- 10) Measure the performance of the wanted signal at the receiver unit associated with the RIB, as defined in the clause 7.6.5, for the relevant carriers specified by the test configuration in clause 4.7 and 4.8.
- 11) Repeat for all supported polarizations.

In addition, for *multi-band RIB*, the following steps shall apply:

12) For *multi-band RIB* and single band tests, repeat the steps above per involved band where single band test configurations and test models shall apply with no carrier activated in the other band.

#### 7.6.4.2.2 *BS type 1-O procedure for co-location blocking*

- 1) Place NR BS and CLTA as specified in clause 4.12.2.3.
- 2) Several CLTA are required to cover the whole co-location blocking frequency ranges. The CLTA shall be selected according to clause 4.12.2.2.
- 3) Align the NR BS and test antenna(s) according to the directions to be tested.
- 4) Connect test antenna and CLTA to the measurement equipment as depicted in annex E.2.4.2.
- 5) The NR BS receives the wanted signal in all supported polarizations, in the receiver target reference direction from the test antenna.
- 6) The OTA co-location blocking interferer is injected via the CLTA. The CLTA is fed with the specified co-location blocking interferer power per supported polarization.
- 7) Generate the wanted signal in receiver target reference direction, all supported polarizations, from the test antenna, according to the applicable test configuration (see clause 4.8) using applicable reference measurement channel to the RIB, according to annex A.1.
- 8) For FDD operation, configure the beam peak direction for the transmitter units associated with the RIB under test according to the declared reference beam direction pair for the appropriate beam identifier with the carrier set-up and power allocation according to the applicable test configuration(s) (see clause 4.8). The transmitter may be turned OFF for the out-of-band blocker tests when the frequency of the blocker is such that no IM2 or IM3 products fall inside the bandwidth of the wanted signal.
- 9) Adjust the signal generators to the type of interfering signals, levels and the frequency offsets as specified for general test requirements in table 7.6.5.1.1-1 and, when applicable, for co-location test requirements in table 7.6.5.1.2-1.
- 10) The CW interfering signal shall be swept with a step size of 1 MHz within the frequency range corresponding to downlink operating bands related to co-located systems (according to declaration D.43).
- 11) Measure the performance of the wanted signal at the receiver unit associated with the RIB, as defined in the clause 7.6.5, for the relevant carriers specified by the test configuration in clause 4.7 and 4.8.

In addition, for *multi-band RIB*, the following steps shall apply:

12) For *multi-band RIB* and single band tests, repeat the steps above per involved band where single band test configurations and test models shall apply with no carrier activated in the other band.

#### 7.6.4.2.3 *BS type 2-O procedure for out-of-band blocking*

- 1) Place BS and the test antenna(s) according to annex E.2.4.1.
- 2) Align the BS and test antenna(s) according to the directions to be tested.
- 3) Connect test antenna(s) to the measurement equipment as shown in annex E.2.4.1.
- 4) The test antenna(s) shall be dual (or single) polarized covering the same frequency ranges as the *BS* and the blocking frequencies. If the test antenna does not cover both the wanted and interfering signal frequencies, separate test antennas for the wanted and interfering signal are required.
- 5) The OTA blocking interferer is injected into the test antenna, with the blocking interferer producing specified interferer field strength level for each supported polarization. The interferer shall be *polarization matched* in-band and the polarization maintained for out-of-band frequencies.
- 6) Generate the wanted signal, according to the applicable test configuration (see clause 4.7 and 4.8) using applicable reference measurement channel to the RIB, according to annex A.1.

- 7) Adjust the signal generators to the type of interfering signals, levels and the frequency offsets as specified for general test requirements in table 7.6.5.2.1-1. The distance between the test object and test antenna injecting the interferer signal is adjusted when necessary to ensure specified interferer signal level to be received.
- 8) The interfering signal shall be swept within the frequency range specified in table 7.6.5.2.1-1 with the step size specified in table 7.6.4.2.3-1 and table 7.6.4.2.3-2.
- 9) Measure the performance of the wanted signal at the receiver unit associated with the RIB, as defined in the clause 7.6.5, for the relevant carriers specified by the test configuration in clause 4.7 and 4.8.

**Table 7.6.4.2.3-1: Interferer signal step size for FR2-1**

Frequency range (MHz)	Minimum supported <i>BS channel bandwidth</i> (MHz)	Measurement step size (MHz)
30 to 6000	50, 100, 200, 400	1
6000 to 60000	50	15
	100	30
	200	60
	400	60

**Table 7.6.4.2.3-2: Interferer signal step size for FR2-2**

Frequency range (MHz)	Minimum supported <i>BS channel bandwidth</i> (MHz)	Measurement step size (MHz)
30 to 6000	100, 400, 800, 1600, 2000	1
6000 to 142000	100	30
	400	60
	800	240
	1600	240
	2000	240

- 10) Repeat for all supported polarizations.

## 7.6.5 Test requirements

### 7.6.5.1 Requirement for *BS type 1-0*

The test requirement consists of general and co-location requirements.

#### 7.6.5.1.1 General

For OTA wanted and OTA interfering signals provided at the RIB using the parameters in table 7.6.5.1.1-1, the following requirements shall be met:

- The throughput shall be  $\geq 95\%$  of the maximum throughput of the reference measurement channel. The reference measurement channel for the OTA wanted signal is identified in clause 10.3.2 in TS 38.104 [2] for each *BS channel bandwidth* and further specified in annex A.1.

For a *multi-band RIB*, the OTA out-of-band requirement shall apply for each supported *operating band*, with the exception that the in-band blocking frequency ranges of all supported *operating bands* according to clause 7.4.2.2 in TS 38.104 [2] shall be excluded from the OTA out-of-band blocking requirement.

For *BS type 1-0* the OTA out-of-band blocking requirement apply from 30 MHz to  $F_{UL\_low} - \Delta f_{OOB}$  and from  $F_{UL\_high} + \Delta f_{OOB}$  up to 12750 MHz, including the downlink frequency range of the FDD *operating band* for BS supporting FDD. The  $\Delta f_{OOB}$  for *BS type 1-0* is defined in table 7.5.2.5.2-0.

Table 7.6.5.1.1-1: OTA out-of-band blocking performance requirement

Wanted signal mean power (dBm)	Interfering signal RMS field-strength (V/m)	Type of interfering signal
EIS <sub>minSENS</sub> + 6 dB (Note 1)	0.36 V/m	CW carrier
NOTE 1: EIS <sub>minSENS</sub> depends on the <i>channel bandwidth</i> as specified in TS 38.104 [2], clause 10.2.1. NOTE 2: The RMS field-strength level in V/m is related to the interferer EIRP level at a distance described as $E = \frac{\sqrt{30EIRP}}{r}$ , where EIRP is in W and r is in m; for example, 0.36 V/m is equivalent to 36 dBm at fixed distance of 30 m.		

### 7.6.5.1.2 Co-location requirement

This additional OTA out-of-band blocking requirement may be applied for the protection of BS receivers when NR, E-UTRA BS, UTRA BS, CDMA BS or GSM/EDGE BS operating in a different frequency band are co-located with a BS.

The interferer power level is specified at the CLTA conducted input(s) as the signal power per supported polarization.

For OTA wanted and OTA interfering signal provided at the RIB using the parameters in table 7.6.5.1.2-1, the following requirements shall be met:

- The throughput shall be  $\geq 95\%$  of the maximum throughput of the reference measurement channel. The reference measurement channel for the OTA wanted signal is identified in clause 10.3.2 in TS 38.104 [2] for each *BS channel bandwidth* and further specified in annex A.1.

For *BS type 1-O* the OTA blocking requirement for co-location with BS in other frequency bands is applied for all operating bands for which co-location protection is provided.

Table 7.6.5.1.2-1: OTA blocking requirement for co-location with BS in other frequency bands

Frequency range of interfering signal	Wanted signal mean power (dBm)	Interfering signal mean power for WA BS (dBm)	Interfering signal mean power for MR BS (dBm)	Interfering signal mean power for LA BS (dBm)	Type of interfering signal
Frequency range of co-located downlink operating band	EIS <sub>minSENS</sub> + 6 dB (Note 1)	+46	+38	+24	CW carrier
NOTE 1: EIS <sub>minSENS</sub> depends on the BS class and on the <i>BS channel bandwidth</i> as specified in TS 38.104 [2], clause 10.2.1. NOTE 2: The requirement does not apply when the interfering signal falls within any of the supported uplink operating band(s) or in $\Delta f_{OOB}$ immediately outside any of the supported uplink operating band(s). NOTE 3: The specified interferer signal power level is applied to all supported CLTA input ports..					

### 7.6.5.2 Requirement for *BS type 2-O*

The test requirement consists of general requirements.

#### 7.6.5.2.1 General requirement

For OTA wanted and OTA interfering signals provided at the RIB using the parameters in table 7.6.5.2.1-1 and table 7.6.5.2.1-2, the following requirements shall be met:

- The throughput shall be  $\geq 95\%$  of the maximum throughput of the reference measurement channel. The reference measurement channel for the OTA wanted signal is identified in clause 10.3.3 in TS 38.104 [2] for each *BS channel bandwidth* and further specified in annex A.1.

For *BS type 2-O* within FR2-1 the OTA out-of-band blocking requirement apply from 30 MHz to  $F_{UL\_low} - \Delta f_{OOB}$  and from  $F_{UL\_high} + \Delta f_{OOB}$  up to  $\min(2^{\text{nd}} \text{ harmonic of the upper frequency edge of the operating band}, 60 \text{ GHz})$ . The  $\Delta f_{OOB}$  for *BS type 2-O* is defined in table 7.5.2.5.3-0.

For *BS type 2-O* within FR2-2 the OTA out-of-band blocking requirement apply from 30 MHz to  $F_{UL\_low} - \Delta f_{OOB}$  and from  $F_{UL\_high} + \Delta f_{OOB}$  up to [142] GHz. The  $\Delta f_{OOB}$  for *BS type 2-O* is defined in table 7.5.2.5.3-0.

**Table 7.6.5.2.1-1: OTA out-of-band blocking performance requirement for FR2-1**

Frequency range of interfering signal (MHz)	Wanted signal mean power (dBm)	Interferer RMS field-strength (V/m)	Type of interfering signal
30 to 12750	$EIS_{REFSENS} + 6$ dB	0.36	CW carrier
12750 to $F_{UL\_low} - \Delta f_{OOB}$		0.1	
$F_{UL\_high} + \Delta f_{OOB}$ to min( $2^{nd}$ harmonic of the upper frequency edge of the operating band, 60000)		0.1	
NOTE: $EIS_{REFSENS}$ is given in TS 38.104 [2], clause 10.3.3.			

**Table 7.6.5.2.1-2: OTA out-of-band blocking performance requirement for FR2-2**

Frequency range of interfering signal (MHz)	Wanted signal mean power (dBm)	Interferer RMS field-strength (V/m)	Type of interfering signal
30 to 12750	$EIS_{REFSENS} + 6$ dB	0.36	CW carrier
12750 to $F_{UL\_low} - \Delta f_{OOB}$		0.1	
$F_{UL\_high} + \Delta f_{OOB}$ to $2^{nd}$ harmonic of the upper frequency edge of the operating band		0.1	
NOTE: $EIS_{REFSENS}$ is given in TS 38.104 [2], clause 10.3.3.			

## 7.7 OTA receiver spurious emissions

### 7.7.1 Definition and applicability

The OTA RX spurious emission is the power of the emissions radiated from the antenna array from a receiver unit.

Unless otherwise stated, all requirements are measured as mean power.

The OTA receiver spurious emission limits for FR1 shall apply from 30 MHz to 12.75 GHz, excluding the frequency range from  $\Delta f_{OBUE}$  below the lowest frequency of each supported downlink *operating band*, up to  $\Delta f_{OBUE}$  above the highest frequency of each supported downlink *operating band*, where the  $\Delta f_{OBUE}$  is defined in clause 6.7.1. For some *operating bands*, the upper limit of the spurious range might be higher than 12.75 GHz in order to comply with the 5<sup>th</sup> harmonic limit of the uplink *operating band*, as specified in ITU-R recommendation SM.329 [5].

For *multi-band RIB* the above exclusion applies for each supported *operating band*.

The OTA receiver spurious emission limits for FR2 shall apply from 30 MHz to  $2^{nd}$  harmonic of the upper frequency edge of the uplink *operating band*, excluding the frequency range from  $\Delta f_{OBUE}$  below the lowest frequency of each supported downlink *operating band*, up to  $\Delta f_{OBUE}$  above the highest frequency of each supported downlink *operating band*, where the  $\Delta f_{OBUE}$  is defined in clause 6.7.1.

For a BS operating in FDD, OTA RX spurious emissions requirement do not apply as they are superseded by the OTA TX spurious emissions requirement. This is due to the fact that TX and RX spurious emissions cannot be distinguished in OTA domain.

For a BS operating in TDD, the OTA RX spurious emissions requirement shall apply during the *transmitter OFF period* only.

The metric used to capture OTA receiver spurious emissions for *BS type 1-O* and *BS type 2-O* is total radiated power (TRP), with the requirement defined at the RIB.

### 7.7.2 Minimum requirement

The minimum requirement for *BS type 1-O* is specified in TS 38.104 [2], clause 10.7.2.

The minimum requirement for *BS type 2-O* is specified in TS 38.104 [2], clause 10.7.3.

### 7.7.3 Test purpose

The test purpose is to verify if the receiver radiated spurious emissions from the BS at the RIB are within the specified minimum requirements.

### 7.7.4 Method of test

#### 7.7.4.1 Initial conditions

Test environment: Normal; see annex B.2.

RF channels to be tested for single carrier, see clause 4.9.1:

- For FR1:
  - B when testing from 30 MHz to  $F_{DL\_low} - \Delta f_{OBUE}$
  - T when testing from  $F_{DL\_high} + \Delta f_{OBUE}$  to 12.75 GHz (or to 5<sup>th</sup> harmonic)
- For FR2:
  - B when testing from 30 MHz to  $F_{DL\_low} - \Delta f_{OBUE}$
  - T when testing from  $F_{DL\_high} + \Delta f_{OBUE}$  to 2<sup>nd</sup> harmonic (or to 60 GHz) for FR2-1
  - T when testing from  $F_{DL\_high} + \Delta f_{OBUE}$  to 2<sup>nd</sup> harmonic (or to 142 GHz) for FR2-2

RF bandwidth positions to be tested in single-band operation, see clause 4.9.1:

- For FR1:
  - $B_{RFBW}$  when testing from 30 MHz to  $F_{DL\_low} - \Delta f_{OBUE}$
  - $T_{RFBW}$  when testing from  $F_{DL\_high} + \Delta f_{OBUE}$  to 12.75 GHz (or to 5<sup>th</sup> harmonic)
- For FR2:
  - $B_{RFBW}$  when testing from 30 MHz to  $F_{DL\_low} - \Delta f_{OBUE}$
  - $T_{RFBW}$  when testing from  $F_{DL\_high} + \Delta f_{OBUE}$  to 2<sup>nd</sup> harmonic (or to 60 GHz) for FR2-1
  - $T_{RFBW}$  when testing from  $F_{DL\_high} + \Delta f_{OBUE}$  to 2<sup>nd</sup> harmonic (or to 142 GHz) for FR2-2

RF bandwidth positions to be tested in multi-band operation, see clause 4.9.1:

- For FR1:
  - $B_{RFBW\_T_{RFBW}}$  when testing from 30 MHz to  $F_{DL\_Blow\_low} - \Delta f_{OBUE}$
  - $B'_{RFBW\_T_{RFBW}}$  when testing from  $F_{DL\_Bhigh\_high} + \Delta f_{OBUE}$  to 12.75 GHz (or to 5<sup>th</sup> harmonic)
  - $B_{RFBW\_T_{RFBW}}$  and  $B'_{RFBW\_T_{RFBW}}$  when testing from  $F_{DL\_Blow\_high} + \Delta f_{OBUE}$  to  $F_{DL\_Bhigh\_low} - \Delta f_{OBUE}$

Directions to be tested: As the requirement is TRP the beam pattern(s) may be set up to optimise the TRP measurement procedure (see annex I).

#### 7.7.4.2 Procedure

The following procedure for measuring TRP is based on the directional power measurements as described in annex I. An alternative method to measure TRP is to use a characterized and calibrated reverberation chamber if so follow steps 1, 3, 4, 5, 7 and 10. When calibrated and operated within the guidance of 3GPP TR 37.941 [29] the measurement methods are applicable and selected depending on availability at the test facility.

- 1) Place the BS at the positioner.
- 2) Align the manufacturer declared coordinate system orientation (D.2) of the BS with the test system.
- 3) Measurements shall use a measurement bandwidth in accordance to the conditions in clause 7.7.5.
- 4) The measurement device characteristics shall be:
  - Detection mode: True RMS.
  - The emission power should be averaged over an appropriate time duration to ensure the measurement is within the measurement uncertainty in Table 4.1.2.3-1 for FR1 and Table 4.1.2.3-2 for FR2.
- 5) Set the TDD BS to receive only.
- 6) Orient the positioner (and BS) in order that the direction to be tested aligns with the test antenna such that measurements to determine TRP can be performed (see annex I).
- 7) Measure the emission at the specified frequencies with specified measurement bandwidth
- 8) Repeat step 6-9 for all directions in the appropriated TRP measurement grid needed for full TRP estimation (see annex I).

NOTE 1: The TRP measurement grid may not be the same for all measurement frequencies.

NOTE 2: The frequency sweep or the TRP measurement grid sweep may be done in any order

- 9) Calculate TRP at each specified frequency using the directional measurements.

In addition, for *multi-band RIB(s)*, the following steps shall apply:

- 10) For *BS type 1-0* and *multi-band RIB(s)* and single band tests, repeat the steps above per involved band where single band test configurations and test models shall apply with no carrier activated in the other band.

## 7.7.5 Test requirement

### 7.7.5.1 Test requirement for *BS type 1-0*

For RX only *multi-band RIB*, the OTA receiver spurious emissions requirements are subject to exclusion zones in each supported *operating band*.

The power of any spurious emission shall not exceed the levels in table 7.7.5.1-1:



**Table 7.7.5.1-1: General OTA BS receiver spurious emission limits for BS type 1-O**

Spurious frequency range	Test limits (Note 6, Note 8)	Measurement bandwidth	Notes
30 MHz – 1 GHz	-36 + X dBm	100 kHz	Note 1, Note 6
1 GHz – 6 GHz	-30 + X dBm	1 MHz	Note 1, Note 2, Note 6
12.75 GHz – 5 <sup>th</sup> harmonic of the upper frequency edge of the UL <i>operating band</i> in GHz	-30 + X dBm	1 MHz	Note 1, Note 2, Note 3, Note 6
12.75 GHz - 26 GHz	-30 + X dBm	1 MHz	Note 1, Note 2, Note 6, Note 9
<p>NOTE 1: Measurement bandwidths as in ITU-R SM.329 [5], s4.1.            NOTE 2: Upper frequency as in ITU-R SM.329 [5], s2.5 table 1.            NOTE 3: Applies for Band for which the upper frequency edge of the UL <i>operating band</i> is greater than 2.55 GHz and less than or equal to 5.2 GHz.            NOTE 4: The frequency range from <math>\Delta f_{\text{OBUE}}</math> below the lowest frequency of the BS transmitter operating band to <math>\Delta f_{\text{OBUE}}</math> above the highest frequency of the BS transmitter <i>operating band</i> may be excluded from the requirement. <math>\Delta f_{\text{OBUE}}</math> is defined in clause 6.7.1. For <i>multi-band RIBs</i>, the exclusion applies for all supported <i>operating bands</i>.            NOTE 5: Void            NOTE 6: X = 9 dB, unless stated differently in regional regulation.            NOTE 7: Void            NOTE 8: Additional limits may apply regionally.            NOTE 9: Applies for Band for which the upper frequency edge of the UL <i>operating band</i> is greater than 5.2 GHz.</p>			

### 7.7.5.2 Test requirement for BS type 2-O

The power of any receiver spurious emission shall not exceed the limits in table 7.7.5.2-1.

**Table 7.7.5.2-1: Radiated Rx spurious emission limits for BS type 2-O**

Spurious frequency range (Note 4)	Limit (Note 5)	Measurement Bandwidth	Note
30 MHz ↔ 1 GHz	-36 dBm	100 kHz	Note 1
1 GHz ↔ 18 GHz	-30 dBm	1 MHz	Note 1
18 GHz ↔ $F_{\text{step},1}$	-20 dBm	10 MHz	Note 2
$F_{\text{step},1}$ ↔ $F_{\text{step},2}$	-15 dBm	10 MHz	Note 2
$F_{\text{step},2}$ ↔ $F_{\text{step},3}$	-10 dBm	10 MHz	Note 2
$F_{\text{step},4}$ ↔ $F_{\text{step},5}$	-10 dBm	10 MHz	Note 2
$F_{\text{step},5}$ ↔ $F_{\text{step},6}$	-15 dBm	10 MHz	Note 2
$F_{\text{step},6}$ ↔ min( $2^{\text{nd}}$ harmonic of the upper frequency edge of the UL <i>operating band</i> in GHz; 60 GHz)	-20 dBm	10 MHz	Note 2, Note 3
<p>NOTE 1: Bandwidth as in ITU-R SM.329 [2], s4.1.            NOTE 2: Limit and bandwidth as in ERC Recommendation 74-01 [19], Annex 2.            NOTE 3: Upper frequency as in ITU-R SM.329 [2], s2.5 table 1.            NOTE 4: The step frequencies <math>F_{\text{step},x}</math> are defined in table 7.7.5.2-2.            NOTE 5: Additional limits may apply regionally.</p>			

**Table 7.7.5.2-2: Step frequencies for defining the radiated Rx spurious emission limits for BS type 2-O**

Operating band	F <sub>step,1</sub> (GHz)	F <sub>step,2</sub> (GHz)	F <sub>step,3</sub> (GHz)	F <sub>step,4</sub> (GHz)	F <sub>step,5</sub> (GHz)	F <sub>step,6</sub> (GHz)
n257	18	23.5	25	31	32.5	41.5
n258	18	21	22.75	29	30.75	40.5
n259	23.5	35.5	38	45	47.5	59.5
n260	25	34	35.5	41.5	43	52
n261	18	25.5	26.0	29.85	30.35	38.35
n262	37.2	45.2	45.7	49.7	50.2	58.2
n263	18	43	53.5	74.5	85	127

In addition, the following requirement may be applied for protection of EESS for BS operating in frequency range 24.25 – 27.5 GHz.

The power of any receiver spurious emission shall not exceed the limits in Table 7.7.5.2-3.

**Table 7.7.5.2-3: Limits for protection of Earth Exploration Satellite Service**

Frequency range	Limit	Measurement Bandwidth	Note
23.6 – 24 GHz	-3 dBm	200 MHz	Note 1
23.6 – 24 GHz	-9 dBm	200 MHz	Note 2
NOTE 1: This limit applies to BS brought into use on or before 1 September 2027. NOTE 2: This limit applies to BS brought into use after 1 September 2027.			

## 7.8 OTA receiver intermodulation

### 7.8.1 Definition and applicability

Third and higher order mixing of the two interfering RF signals can produce an interfering signal in the band of the desired channel. Intermodulation response rejection is a measure of the capability of the receiver unit to receive a wanted signal on its assigned channel frequency in the presence of two interfering signals which have a specific frequency relationship to the wanted signal. The requirement is defined as a directional requirement at the *RIB*.

The wanted and interfering signals apply to each supported polarization, under the assumption of *polarization match*.

### 7.8.2 Minimum requirement

The minimum requirement for *BS type 1-O* is in TS 38.104 [2], clause 10.8.2.

The minimum requirement for *BS type 2-O* is in TS 38.104 [2], clause 10.8.3.

### 7.8.3 Test purpose

The test purpose is to verify the ability of the *BS* receiver to inhibit the generation of intermodulation products in its non-linear elements caused by the presence of two high-level interfering signals at frequencies with a specific relationship to the frequency of the wanted signal.

### 7.8.4 Method of test

#### 7.8.4.1 Initial conditions

Test environment: Normal, annex B.2.

RF channels to be tested for single carrier: *M*; see clause 4.9.1.

*Base Station RF Bandwidth* positions to be tested for multi-carrier and/or CA:

- $M_{\text{RFBW}}$  for single-band operation, see clause 4.9.1.
- $B_{\text{RFBW}_T}$  and  $B'_{\text{RFBW}_T}$  for multi-band operation, see clause 4.9.1.

Directions to be tested:

- OTA REFSENS receiver target reference direction (D.54).
- In addition, for *BS type 1-O*, receiver target reference direction (D.31).

## 7.8.4.2 Procedure

- 1) Place the BS with its manufacturer declared coordinate system reference point in the same place as calibrated point in the test system, as shown in annex E.2.6.
- 2) Align the manufacturer declared coordinate system orientation of the BS with the test system.
- 3) Align the BS with the test antenna in the declared direction to be tested.
- 4) Align the BS to that the wanted signal and interferer signal is *polarization matched* with the test antenna(s).
- 5) Configure the beam peak direction of the BS according to declared reference beam direction pair for the appropriate beam identifier.
- 6) For FDD operation, set the BS to transmit the beam(s) of the same operational band as the *OTA REFSENS RoAoA* or OSDD being tested according to the appropriate test configuration in clauses 4.7 and 4.8.
- 7) Set the test signal mean power so the calibrated radiated power at the BS Antenna Array coordinate system reference point is as specified as follows:
  - a) Set the signal generator for the wanted signal to transmit as specified in table 7.8.5.1-1 (for general intermodulation) or 7.8.5.1-3 (for narrowband intermodulation) for *BS type 1-O*, or table 7.8.5.2-1 (for general intermodulation) for *BS type 2-O*.
  - b) Set the signal generator for the interfering signal at the same frequency as the wanted signal to transmit as specified in table 7.8.5.1-1 (for general intermodulation) or 7.8.5.1-3 (for narrowband intermodulation) for *BS type 1-O*, or table 7.8.5.2-1 (for general intermodulation) for *BS type 2-O*.
- 8) Set the signal generator for the interfering signal to transmit at the frequency offset and as specified in table 7.8.5.1-2 (for general intermodulation) or 7.8.5.1-4 (for narrowband intermodulation) for *BS type 1-O*, or table 7.8.5.2-2 (for general intermodulation) for *BS type 2-O*.
- 9) Measure the throughput according to annex A.1 for each supported polarization, for multi-carrier and/or CA operation the throughput shall be measured for relevant carriers specified by the test configuration specified in clause 4.7.
- 10) Repeat for all the specified measurement directions and supported polarizations.

In addition, for *multi-band RIB(s)*, the following steps shall apply:

- 11) For *multi-band RIBs* and single band tests, repeat the steps above per involved band where single band test configurations and test models shall apply with no carrier activated in the other band.

## 7.8.5 Test requirement

### 7.8.5.1 *BS type 1-O*

The requirement shall apply at the RIB when the AoA of the incident wave of a received signal and the interfering signal are from the same direction, and:

- when the wanted signal is based on  $EIS_{\text{REFSENS}}$ : the AoA of the incident wave of a received signal and the interfering signal are within the *FRI OTA REFSENS RoAoA*.

- when the wanted signal is based on  $EIS_{\min SENS}$ : the AoA of the incident wave of a received signal and the interfering signal are within the  $minSENS RoAoA$ .

The throughput shall be  $\geq 95\%$  of the maximum throughput of the reference measurement channel, with a wanted signal at the assigned channel frequency and two interfering signals at the RIB with the conditions specified in tables 7.8.5.1-1 and 7.8.5.1-2 for intermodulation performance and in tables 7.8.5.1-3 and 7.8.5.1-4 for narrowband intermodulation performance. Narrowband intermodulation requirements shall not be applied for band n104.

The reference measurement channel for the wanted signal is identified in table 7.3.5.2-1, table 7.3.5.2-2 and table 7.3.5.2-3 for each *BS channel bandwidth* and further specified in annex A.1.

The subcarrier spacing for the modulated interfering signal shall be the same as the subcarrier spacing for the wanted signal, except for the case of wanted signal subcarrier spacing 60 kHz and *BS channel bandwidth*  $\leq 20$  MHz, for which the subcarrier spacing of the interfering signal should be 30 kHz.

The receiver intermodulation requirement is applicable outside the Base Station RF Bandwidth or Radio Bandwidth edges. The interfering signal offset is defined relative to the Base Station RF Bandwidth edges or Radio Bandwidth edges.

For a RIBs supporting operation in non-contiguous spectrum within any *operating band*, the narrowband intermodulation requirement shall apply in addition inside any sub-block gap in case the sub-block gap is at least as wide as the *BS channel bandwidth* of the NR interfering signal in tables 7.8.5.1-2 and 7.8.5.1-4. The interfering signal offset is defined relative to the sub-block edges inside the sub-block gap.

For *multi-band RIBs*, the intermodulation requirement shall apply in addition inside any Inter RF Bandwidth gap, in case the gap size is at least twice as wide as the NR interfering signal centre frequency offset from the Base Station RF Bandwidth edge.

For *multi-band RIBs*, the narrowband intermodulation requirement shall apply in addition inside any Inter RF Bandwidth gap in case the gap size is at least as wide as the NR interfering signal in tables 7.8.5.1-2 and 7.8.5.1-4. The interfering signal offset is defined relative to the Base Station RF Bandwidth edges inside the Inter RF Bandwidth gap.

**Table 7.8.5.1-1: General intermodulation requirement**

BS class	Wanted Signal mean power (dBm)	Mean power of interfering signals (dBm)	Type of interfering signal
Wide Area BS	$EIS_{REFSENS} + 6$ dB	$-52 - \Delta_{OTAREFSENS}$	See table 7.8.5.1-2
	$EIS_{\min SENS} + 6$ dB	$-52 - \Delta_{\min SENS}$	
Medium Range BS	$EIS_{REFSENS} + 6$ dB	$-47 - \Delta_{OTAREFSENS}$	
	$EIS_{\min SENS} + 6$ dB	$-47 - \Delta_{\min SENS}$	
Local Area BS	$EIS_{REFSENS} + 6$ dB	$-44 - \Delta_{OTAREFSENS}$	
	$EIS_{\min SENS} + 6$ dB	$-44 - \Delta_{\min SENS}$	
NOTE: $EIS_{REFSENS}$ and $EIS_{\min SENS}$ depend on the BS class and on the <i>BS channel bandwidth</i> as specified in TS 38.104 [2], clause 10.3.2 and 10.2.1.			

Table 7.8.5.1-2: Interfering signals for intermodulation requirement

<i>BS channel bandwidth of the lowest/highest carrier received (MHz)</i>	<i>Interfering signal centre frequency offset from the lower/upper base station RF Bandwidth edge (MHz)</i>	<i>Type of interfering signal (Note 3)</i>
5	±7.5	CW
	±17.5	5MHz DFT-s-OFDM NR signal (Note 1)
10	±7.465	CW
	±17.5	5MHz DFT-s-OFDM NR signal (Note 1)
15	±7.43	CW
	±17.5	5MHz DFT-s-OFDM NR signal (Note 1)
20	±7.395	CW
	±17.5	5MHz DFT-s-OFDM NR signal (Note 1)
25	±7.465	CW
	±25	20 MHz DFT-s-OFDM NR signal (Note 2)
30	±7.43	CW
	±25	20MHz DFT-s-OFDM NR signal (Note 2)
35	±7.44	CW
	±25	20 MHz DFT-s-OFDM NR signal, (Note 2)
40	±7.45	CW
	±25	20MHz DFT-s-OFDM NR signal (Note 2)
45	±7.37	CW
	±25	20 MHz DFT-s-OFDM NR signal, (Note 2)
50	±7.35	CW
	±25	20MHz DFT-s-OFDM NR signal (Note 2)
60	±7.49	CW
	±25	20MHz DFT-s-OFDM NR signal (Note 2)
70	±7.42	CW
	±25	20 MHz DFT-s-OFDM NR signal (Note 2)
80	±7.44	CW
	±25	20MHz DFT-s-OFDM NR signal (Note 2)
90	±7.46	CW
	±25	20 MHz DFT-s-OFDM NR signal (Note 2)
100	±7.48	CW
	±25	20MHz DFT-s-OFDM NR signal (Note 2)

NOTE 1: For the 15 kHz subcarrier spacing, the number of RB is 25. For the 30 kHz subcarrier spacing, the number of RB is 10.

NOTE 2: For the 15 kHz subcarrier spacing, the number of RB is 100. For the 30 kHz subcarrier spacing, the number of RB is 50. For the 60 kHz subcarrier spacing, the number of RB is 24.

NOTE 3: The RBs shall be placed adjacent to the transmission bandwidth configuration edge which is closer to the *Base Station RF Bandwidth* edge.

**Table 7.8.5.1-3: Narrowband intermodulation performance requirement in FR1**

BS class	Wanted signal mean power (dBm)	Interfering signal mean power (dBm)	Type of interfering signal
Wide Area BS	$EIS_{REFSENS} + 6$ dB (Note 1)	$-52 - \Delta_{OTAREFSNS}$	See table 7.8.5.1-4
	$EIS_{minSENS} + 6$ dB (Note 1)	$-52 - \Delta_{minSENS}$	
Medium Range BS	$EIS_{REFSENS} + 6$ dB (Note 1)	$-47 - \Delta_{OTAREFSNS}$	
	$EIS_{minSENS} + 6$ dB (Note 1)	$-47 - \Delta_{minSENS}$	
Local Area BS	$EIS_{REFSENS} + 6$ dB (Note 1)	$-44 - \Delta_{OTAREFSNS}$	
	$EIS_{minSENS} + 6$ dB (Note 1)	$-44 - \Delta_{minSENS}$	
NOTE: $EIS_{REFSENS}$ and $EIS_{minSENS}$ depends on the <i>BS channel bandwidth</i> as specified in TS 38.104 [2], clause 10.3.2 and 10.2.1.			

**Table 7.8.5.1-4: Interfering signals for narrowband intermodulation requirement in FR1**

<b>BS channel bandwidth of the lowest/highest carrier received (MHz)</b>	<b>Interfering RB centre frequency offset from the lower/upper Base Station RF Bandwidth edge or sub-block edge inside a sub-block gap (kHz) (Note 3)</b>	<b>Type of interfering signal</b>
5	±360	CW
	±1420	5MHz DFT-s-OFDM NR signal, 1 RB (NOTE 1)
10	±370	CW
	±1960	5MHz DFT-s-OFDM NR signal, 1 RB (NOTE 1)
15 (NOTE 2)	±380	CW
	±1960	5MHz DFT-s-OFDM NR signal, 1 RB (NOTE 1)
20 (NOTE 2)	±390	CW
	±2320	5MHz DFT-s-OFDM NR signal, 1 RB (NOTE 1)
25 (NOTE 2)	±325	CW
	±2350	20MHz DFT-s-OFDM NR signal, 1 RB (NOTE 1)
30 (NOTE 2)	±335	CW
	±2350	20MHz DFT-s-OFDM NR signal, 1 RB (NOTE 1)
35 (NOTE 2)	±345	CW
	±2710	20 MHz DFT-s-OFDM NR signal, 1 RB (NOTE 1)
40 (NOTE 2)	±355	CW
	±2710	20MHz DFT-s-OFDM NR signal, 1 RB (NOTE 1)
45 (NOTE 2)	±365	CW
	±2710	20 MHz DFT-s-OFDM NR signal, 1 RB (NOTE 1)
50 (NOTE 2)	±375	CW
	±2710	20MHz DFT-s-OFDM NR signal, 1 RB (NOTE 1)
60 (NOTE 2)	±395	CW
	±2710	20MHz DFT-s-OFDM NR signal, 1 RB (NOTE 1)
70 (NOTE 2)	±415	CW
	±2710	20MHz DFT-s-OFDM NR signal, 1 RB (NOTE 1)
80 (NOTE 2)	±435	CW
	±2710	20MHz DFT-s-OFDM NR signal, 1 RB (NOTE 1)
90 (NOTE 2)	±365	CW
	±2530	20MHz DFT-s-OFDM NR signal, 1 RB (NOTE 1)
100 (NOTE 2)	±385	CW
	±2530	20MHz DFT-s-OFDM NR signal, 1 RB (NOTE 1)



NOTE 1: Interfering signal consisting of one resource block positioned at the stated offset, the <i>BS channel bandwidth</i> of the interfering signal is located adjacently to the lower/upper Base Station RF Bandwidth edge.
NOTE 2: This requirement shall apply only for a G-FRC mapped to the frequency range at the channel edge adjacent to the interfering signals.
NOTE 3: The centre of the interfering RB refers to the frequency location between the two central subcarriers.

### 7.8.5.2 *BS type 2-0*

Throughput shall be  $\geq 95\%$  of the maximum throughput of the reference measurement channel, with OTA wanted signal at the assigned channel frequency and two OTA interfering signals provided at the RIB using the parameters in tables 7.8.5.2-1 and 7.8.5.2-2. All of the OTA test signals arrive from the same direction, and the requirement is valid if the signals arrive from any direction within the *FR2 OTA REFSENS RoAoA*. The reference measurement channel for the wanted signal is identified in table 7.3.5.3-1 for each *BS channel bandwidth* and further specified in annex A.1.

The subcarrier spacing for the modulated interfering signal shall be the same as the subcarrier spacing for the wanted signal except for FR2-2 with 400 MHz, 800 MHz, 1600 MHz and 2000 MHz case.

The receiver intermodulation requirement is applicable outside the Base Station RF Bandwidth. The interfering signal offset is defined relative to the Base Station RF Bandwidth edges.

**Table 7.8.5.2-1: General intermodulation requirement**

<i>BS channel bandwidth</i> of the lowest/highest carrier received (MHz)	Mean power of interfering signals (dBm)	Wanted signal mean power (dBm)	Type of interfering signal
50, 100, 200, 400, 800, 1600, 2000	$EIS_{REFSENS\_50M} + 25 + \Delta_{FR2\_REFSENS}$ dB (Note 2), $EIS_{REFSENS\_50M} + 28 + \Delta_{FR2\_REFSENS}$ (Note 3)	$EIS_{REFSENS} + 6$ dB	See table 7.8.5.2-2
NOTE 1: $EIS_{REFSENS}$ and $EIS_{REFSENS\_50M}$ are given in TS 38.104 [2], clause 10.3.3.			
NOTE 2: Applicable to bands defined within the frequency spectrum range of FR2-1.			
NOTE 3: Applicable to bands defined within the frequency spectrum range of FR2-2.			

Table 7.8.5.2-2: Interfering signals for intermodulation requirement

Frequency range	BS channel bandwidth of the lowest/highest carrier received (MHz)	Interfering signal centre frequency offset from the Base Station RF Bandwidth edge (MHz)	Type of interfering signal
FR2-1	50	$\pm 7.5$	CW
		$\pm 40$	50MHz DFT-s-OFDM NR signal (Note 1)
	100	$\pm 6.88$	CW
		$\pm 40$	50MHz DFT-s-OFDM NR signal (Note 1)
	200	$\pm 5.64$	CW
		$\pm 40$	50MHz DFT-s-OFDM NR signal (Note 1)
	400	$\pm 6.02$	CW
		$\pm 45$	50MHz DFT-s-OFDM NR signal (Note 1)
FR2-2	100	$\pm 7.5$	CW
		$\pm 65$	100MHz DFT-s-OFDM NR signal (Note 2)
	400	$\pm 6.28$	CW
		$\pm 70$	100MHz DFT-s-OFDM NR signal (Note 2)
	800	$[\pm 7.3]$	CW
		$[\pm 105]$	100MHz DFT-s-OFDM NR signal (Note 2)
	1600	$[\pm 5.86]$	CW
		$[\pm 145]$	100MHz DFT-s-OFDM NR signal (Note 2)
	2000	$\pm 7.48$	CW
		$\pm 210$	100MHz DFT-s-OFDM NR signal (Note 2)
NOTE 1: For the 60 kHz subcarrier spacing, the number of RB is 64. For the 120 kHz subcarrier spacing, the number of RB is 32.			
NOTE 2: Number of RBs is 64 with 120 kHz subcarrier spacing.			

## 7.9 OTA in-channel selectivity

### 7.9.1 Definition and applicability

In-channel selectivity (ICS) is a measure of the receiver ability to receive a wanted signal at its assigned resource block locations in the presence of an interfering signal received at a larger power spectral density. In this condition a throughput requirement shall be met for a specified reference measurement channel. The interfering signal shall be an NR signal as specified in annex E in TS 38.141-1 [3] and shall be time aligned with the wanted signal.

### 7.9.2 Minimum requirement

The minimum requirement for *BS type 1-O* is in TS 38.104 [2], clause 10.9.2.

The minimum requirement for *BS type 2-O* is in TS 38.104 [2], clause 10.9.3.

### 7.9.3 Test purpose

The purpose of this test is to verify the BS receiver ability to suppress the IQ leakage.

### 7.9.4 Method of test

#### 7.9.4.1 Initial conditions

Test environment: Normal, see annex B.2.

RF channels to be tested for single carrier: M; see clause 4.9.1.

Directions to be tested:

- For BS type 1-O, receiver target reference direction (D.31),
- For BS type 2-O, OTA REFSENS receiver target reference direction (D.54).

#### 7.9.4.2 Procedure

- 1) Place the BS with its manufacturer declared coordinate system reference point in the same place as calibrated point in the test system, as shown in annex E.2.7.
- 2) Align the manufacturer declared coordinate system orientation of the BS with the test system.
- 3) Align the BS with the test antenna in the declared direction to be tested.
- 4) Align the BS to that the wanted signal and interferer signal is *polarization matched* with the test antenna(s).
- 5) Configure the beam peak direction for the transmitter according to the declared reference beam direction pair for the appropriate beam identifier.
- 6) For FDD operation, set the BS to transmit beam(s) of the same operational band as the *OTA REFSENS RoAoA* or *OSDD* being tested according to the appropriate test configuration in clauses 4.7 and 4.8.
- 7) Set the test signal mean power so the calibrated radiated power at the BS Antenna Array coordinate system reference point is as specified as follows:
  - a) Adjust the signal generator for the wanted signal as specified in:
 

For BS type 1-O, table 7.9.5.1-1 for BS of Wide Area BS class, in table 7.9.5.1-2 for BS of Local Area BS class and in table 7.9.5.1-3 for BS of Medium Range BS class on one side of the  $F_C$ .

For BS type 2-O, tables 7.9.5.2-1, 7.9.5.2-2 and 7.9.5.2-3 on one side of the  $F_C$ .
  - b) Adjust the signal generator for the interfering signal as specified in:
 

For BS type 1-O, table 7.9.5.1-1 for BS of Wide Area BS class, in table 7.9.5.1-2 for BS of Local Area BS class and in table 7.9.5.1-3 for BS of Medium Range BS class at opposite side of the  $F_C$  and adjacent to the wanted signal.

For BS type 2-O, tables 7.9.5.2-1, 7.9.5.2-2 and 7.9.5.2-3 at opposite side of the  $F_C$  and adjacent to the wanted signal.
- 8) Measure throughput according to annex A.1 for each supported polarization.
- 9) Repeat the measurement with the wanted signal on the other side of the  $F_C$ , and the interfering signal at opposite side of the  $F_C$  and adjacent to the wanted signal.
- 10) Repeat for all the specified measurement directions and supported polarizations.

In addition, for *multi-band RIB(s)*, the following steps shall apply:

- 9) For *multi-band RIBs* and single band tests, repeat the steps above per involved band where single band test configurations and test models shall apply with no carrier activated in the other band.

## 7.9.5 Test requirement

### 7.9.5.1 BS type 1-O

The requirement shall apply at the RIB when the AoA of the incident wave of the received signal and the interfering signal are the same direction and are within the *minSENS RoAoA*

The wanted and interfering signals applies to each supported polarization, under the assumption of *polarization match*.

For a wanted and an interfering signal coupled to the RIB, the following requirements shall be met:

- For *BS type 1-O*, the throughput shall be  $\geq 95\%$  of the maximum throughput of the reference measurement channel as specified in annex A.1 with parameters specified in tables 7.9.5.1-1 and 7.9.5.1-1a for Wide Area BS, in tables 7.9.5.1-2 and 7.9.5.1-2a for Medium Range BS and in tables 7.9.5.1-3 and 7.9.5.1-3a for Local Area BS.

**Table 7.9.5.1-1: Wide Area BS in-channel selectivity for  $f \leq 6$  GHz**

BS channel bandwidth (MHz)	Subcarrier spacing (kHz)	Reference measurement channel (annex A.1)	Wanted signal mean power (dBm)			Interfering signal mean power (dBm)	Type of interfering signal
			$f \leq 3.0$ GHz	3.0 GHz < $f \leq 4.2$ GHz	4.2 GHz < $f \leq 6.0$ GHz		
5	15	G-FR1-A1-7	-98.9- $\Delta_{\text{minSENS}}$	-98.5- $\Delta_{\text{minSENS}}$	-98.2- $\Delta_{\text{minSENS}}$	-81.4 - $\Delta_{\text{minSENS}}$	DFT-s-OFDM NR signal, 15 kHz SCS, 10 RBs
10, 15, 20, 25, 30, 35	15	G-FR1-A1-1	-97- $\Delta_{\text{minSENS}}$	-96.6- $\Delta_{\text{minSENS}}$	-96.3- $\Delta_{\text{minSENS}}$	-77.4 - $\Delta_{\text{minSENS}}$	DFT-s-OFDM NR signal, 15 kHz SCS, 25 RBs
40, 45, 50	15	G-FR1-A1-4	-90.6- $\Delta_{\text{minSENS}}$	-90.2- $\Delta_{\text{minSENS}}$	-89.9- $\Delta_{\text{minSENS}}$	-71.4 - $\Delta_{\text{minSENS}}$	DFT-s-OFDM NR signal, 15 kHz SCS, 100 RBs
5	30	G-FR1-A1-8	-99.6- $\Delta_{\text{minSENS}}$	-99.2- $\Delta_{\text{minSENS}}$	-98.9- $\Delta_{\text{minSENS}}$	-81.4 - $\Delta_{\text{minSENS}}$	DFT-s-OFDM NR signal, 30 kHz SCS, 5 RBs
10, 15, 20, 25, 30, 35	30	G-FR1-A1-2	-97.1- $\Delta_{\text{minSENS}}$	-96.7- $\Delta_{\text{minSENS}}$	-96.4- $\Delta_{\text{minSENS}}$	-78.4 - $\Delta_{\text{minSENS}}$	DFT-s-OFDM NR signal, 30 kHz SCS, 10 RBs
40, 45, 50, 60, 70, 80, 90, 100	30	G-FR1-A1-5	-90.9- $\Delta_{\text{minSENS}}$	-90.5- $\Delta_{\text{minSENS}}$	-90.2- $\Delta_{\text{minSENS}}$	-71.4 - $\Delta_{\text{minSENS}}$	DFT-s-OFDM NR signal, 30 kHz SCS, 50 RBs
10, 15, 20, 25, 30, 35	60	G-FR1-A1-9	-96.5- $\Delta_{\text{minSENS}}$	-96.1- $\Delta_{\text{minSENS}}$	-95.8- $\Delta_{\text{minSENS}}$	-78.4 - $\Delta_{\text{minSENS}}$	DFT-s-OFDM NR signal, 60 kHz SCS, 5 RBs
40, 45, 50, 60, 70, 80, 90, 100	60	G-FR1-A1-6	-91- $\Delta_{\text{minSENS}}$	-90.6- $\Delta_{\text{minSENS}}$	-90.3- $\Delta_{\text{minSENS}}$	-71.6 - $\Delta_{\text{minSENS}}$	DFT-s-OFDM NR signal, 60 kHz SCS, 24 RBs
NOTE: Wanted and interfering signal are placed adjacently around $F_c$ , where the $F_c$ is defined for <i>BS channel bandwidth</i> of the wanted signal according to the table 5.4.2.2-1 in TS 38.104 [2]. The aggregated wanted and interferer signal shall be centred in the BS channel bandwidth of the wanted signal.							

Table 7.9.5.1-1a: Wide Area BS in-channel selectivity for  $6 < f \leq 7.125$  GHz

BS channel bandwidth (MHz)	Subcarrier spacing (kHz)	Reference measurement channel (annex A.1)	Wanted signal mean power (dBm)	Interfering signal mean power (dBm)	Type of interfering signal
20, 30	15	G-FR1-A1-1	-94.9 - $\Delta_{\text{minSENS}}$	-76.4 - $\Delta_{\text{minSENS}}$	DFT-s-OFDM NR signal, 15 kHz SCS, 25 RBs
40, 50	15	G-FR1-A1-4	-88.5 - $\Delta_{\text{minSENS}}$	-70.4 - $\Delta_{\text{minSENS}}$	DFT-s-OFDM NR signal, 15 kHz SCS, 100 RBs
20, 30	30	G-FR1-A1-2	-95.0 - $\Delta_{\text{minSENS}}$	-77.4 - $\Delta_{\text{minSENS}}$	DFT-s-OFDM NR signal, 30 kHz SCS, 10 RBs
40, 50, 60, 70, 80, 90, 100	30	G-FR1-A1-5	-88.8 - $\Delta_{\text{minSENS}}$	-70.4 - $\Delta_{\text{minSENS}}$	DFT-s-OFDM NR signal, 30 kHz SCS, 50 RBs
20, 30	60	G-FR1-A1-9	-94.4 - $\Delta_{\text{minSENS}}$	-77.4 - $\Delta_{\text{minSENS}}$	DFT-s-OFDM NR signal, 60 kHz SCS, 5 RBs
40, 50, 60, 70, 80, 90, 100	60	G-FR1-A1-6	-88.9 - $\Delta_{\text{minSENS}}$	-70.6 - $\Delta_{\text{minSENS}}$	DFT-s-OFDM NR signal, 60 kHz SCS, 24 RBs

Table 7.9.5.1-2: Medium Range BS in-channel selectivity for  $f \leq 6.0$  GHz

BS channel bandwidth (MHz)	Subcarrier spacing (kHz)	Reference measurement channel (annex A.1)	Wanted signal mean power (dBm)			Interfering signal mean power (dBm)	Type of interfering signal
			$f \leq 3.0$ GHz	3.0 GHz < $f \leq 4.2$ GHz	4.2 GHz < $f \leq 6.0$ GHz		
5	15	G-FR1-A1-7	-93.9- $\Delta_{\text{minSENS}}$	-93.5- $\Delta_{\text{minSENS}}$	-93.2- $\Delta_{\text{minSENS}}$	-76.4 - $\Delta_{\text{minSENS}}$	DFT-s-OFDM NR signal, 15 kHz SCS, 10 RBs
10, 15, 20, 25, 30, 35	15	G-FR1-A1-1	-92- $\Delta_{\text{minSENS}}$	-91.6- $\Delta_{\text{minSENS}}$	-91.3- $\Delta_{\text{minSENS}}$	-72.4 - $\Delta_{\text{minSENS}}$	DFT-s-OFDM NR signal, 15 kHz SCS, 25 RBs
40, 45, 50	15	G-FR1-A1-4	-85.6- $\Delta_{\text{minSENS}}$	-85.2- $\Delta_{\text{minSENS}}$	-84.9- $\Delta_{\text{minSENS}}$	-66.4 - $\Delta_{\text{minSENS}}$	DFT-s-OFDM NR signal, 15 kHz SCS, 100 RBs
5	30	G-FR1-A1-8	-94.6- $\Delta_{\text{minSENS}}$	-94.2- $\Delta_{\text{minSENS}}$	-93.9- $\Delta_{\text{minSENS}}$	-76.4 - $\Delta_{\text{minSENS}}$	DFT-s-OFDM NR signal, 30 kHz SCS, 5 RBs
10, 15, 20, 25, 30, 35	30	G-FR1-A1-2	-92.1- $\Delta_{\text{minSENS}}$	-91.7- $\Delta_{\text{minSENS}}$	-91.4- $\Delta_{\text{minSENS}}$	-73.4 - $\Delta_{\text{minSENS}}$	DFT-s-OFDM NR signal, 30 kHz SCS, 10 RBs
40, 45, 50, 60, 70, 80, 90, 100	30	G-FR1-A1-5	-85.9- $\Delta_{\text{minSENS}}$	-85.5- $\Delta_{\text{minSENS}}$	-85.2- $\Delta_{\text{minSENS}}$	-66.4 - $\Delta_{\text{minSENS}}$	DFT-s-OFDM NR signal, 30 kHz SCS, 50 RBs
10, 15, 20, 25, 30, 35	60	G-FR1-A1-9	-91.5- $\Delta_{\text{minSENS}}$	-91.1- $\Delta_{\text{minSENS}}$	-90.8- $\Delta_{\text{minSENS}}$	-73.4 - $\Delta_{\text{minSENS}}$	DFT-s-OFDM NR signal, 60 kHz SCS, 5 RBs
40, 45, 50, 60, 70, 80, 90, 100	60	G-FR1-A1-6	-86- $\Delta_{\text{minSENS}}$	-85.6- $\Delta_{\text{minSENS}}$	-85.3- $\Delta_{\text{minSENS}}$	-66.6 - $\Delta_{\text{minSENS}}$	DFT-s-OFDM NR signal, 60 kHz SCS, 24 RBs
NOTE: Wanted and interfering signal are placed adjacently around $F_c$ , where the $F_c$ is defined for <i>BS channel bandwidth</i> of the wanted signal according to the table 5.4.2.2-1 in TS 38.104 [2]. The aggregated wanted and interferer signal shall be centred in the BS channel bandwidth of the wanted signal.							

Table 7.9.5.1-2a: Medium Range BS in-channel selectivity for  $6.0 < f \leq 7.125$  GHz

BS channel bandwidth (MHz)	Subcarrier spacing (kHz)	Reference measurement channel (annex A.1)	Wanted signal mean power (dBm)	Interfering signal mean power (dBm)	Type of interfering signal
20, 30	15	G-FR1-A1-1	-89.9 - $\Delta_{\text{minSENS}}$	-71.4 - $\Delta_{\text{minSENS}}$	DFT-s-OFDM NR signal, 15 kHz SCS, 25 RBs
40, 50	15	G-FR1-A1-4	-83.5 - $\Delta_{\text{minSENS}}$	-65.4 - $\Delta_{\text{minSENS}}$	DFT-s-OFDM NR signal, 15 kHz SCS, 100 RBs
20, 30	30	G-FR1-A1-2	-90.0 - $\Delta_{\text{minSENS}}$	-72.4 - $\Delta_{\text{minSENS}}$	DFT-s-OFDM NR signal, 30 kHz SCS, 10 RBs
40, 50, 60, 70, 80, 90, 100	30	G-FR1-A1-5	-83.8 - $\Delta_{\text{minSENS}}$	-65.4 - $\Delta_{\text{minSENS}}$	DFT-s-OFDM NR signal, 30 kHz SCS, 50 RBs
20, 30	60	G-FR1-A1-9	-89.4 - $\Delta_{\text{minSENS}}$	-72.4 - $\Delta_{\text{minSENS}}$	DFT-s-OFDM NR signal, 60 kHz SCS, 5 RBs
40, 50, 60, 70, 80, 90, 100	60	G-FR1-A1-6	-83.9 - $\Delta_{\text{minSENS}}$	-65.6 - $\Delta_{\text{minSENS}}$	DFT-s-OFDM NR signal, 60 kHz SCS, 24 RBs

Table 7.9.5.1-3: Local area BS in-channel selectivity for  $f \leq 6.0$  GHz

BS channel bandwidth (MHz)	Subcarrier spacing (kHz)	Reference measurement channel (annex A.1)	Wanted signal mean power (dBm)			Interfering signal mean power (dBm)	Type of interfering signal
			$f \leq 3.0$ GHz	3.0 GHz < $f \leq 4.2$ GHz	4.2 GHz < $f \leq 6.0$ GHz		
5	15	G-FR1-A1-7	-90.9- $\Delta_{\min\text{SENS}}$	-90.5- $\Delta_{\min\text{SENS}}$	-90.2- $\Delta_{\min\text{SENS}}$	-73.4 - $\Delta_{\min\text{SENS}}$	DFT-s-OFDM NR signal, 15 kHz SCS, 10 RBs
10, 15, 20, 25, 30, 35	15	G-FR1-A1-1	-89- $\Delta_{\min\text{SENS}}$	-88.6- $\Delta_{\min\text{SENS}}$	-88.3- $\Delta_{\min\text{SENS}}$	-69.4 - $\Delta_{\min\text{SENS}}$	DFT-s-OFDM NR signal, 15 kHz SCS, 25 RBs
40, 45, 50	15	G-FR1-A1-4	-82.6- $\Delta_{\min\text{SENS}}$	-82.2- $\Delta_{\min\text{SENS}}$	-81.9- $\Delta_{\min\text{SENS}}$	-63.4 - $\Delta_{\min\text{SENS}}$	DFT-s-OFDM NR signal, 15 kHz SCS, 100 RBs
5	30	G-FR1-A1-8	-91.6- $\Delta_{\min\text{SENS}}$	-91.2- $\Delta_{\min\text{SENS}}$	-90.9- $\Delta_{\min\text{SENS}}$	-73.4 - $\Delta_{\min\text{SENS}}$	DFT-s- NR signal, 30 kHz SCS, 5 RBs
10, 15, 20, 25, 30, 35	30	G-FR1-A1-2	-89.1- $\Delta_{\min\text{SENS}}$	-88.7- $\Delta_{\min\text{SENS}}$	-88.4- $\Delta_{\min\text{SENS}}$	-70.4 - $\Delta_{\min\text{SENS}}$	DFT-s-OFDM NR signal, 30 kHz SCS, 10 RBs
40, 45, 50, 60, 70, 80, 90, 100	30	G-FR1-A1-5	-82.9- $\Delta_{\min\text{SENS}}$	-82.5- $\Delta_{\min\text{SENS}}$	-82.2- $\Delta_{\min\text{SENS}}$	-63.4 - $\Delta_{\min\text{SENS}}$	DFT-s-OFDM NR signal, 30 kHz SCS, 50 RBs
10, 15, 20, 25, 30, 35	60	G-FR1-A1-9	-88.5- $\Delta_{\min\text{SENS}}$	-88.1- $\Delta_{\min\text{SENS}}$	-87.8- $\Delta_{\min\text{SENS}}$	-70.4 - $\Delta_{\min\text{SENS}}$	DFT-s-OFDM NR signal, 60 kHz SCS, 5 RBs
40, 45, 50, 60, 70, 80, 90, 100	60	G-FR1-A1-6	-83- $\Delta_{\min\text{SENS}}$	-82.6- $\Delta_{\min\text{SENS}}$	-82.3- $\Delta_{\min\text{SENS}}$	-63.6 - $\Delta_{\min\text{SENS}}$	DFT-s-OFDM NR signal, 60 kHz SCS, 24 RBs
NOTE: Wanted and interfering signal are placed adjacently around $F_c$ , where the $F_c$ is defined for BS channel bandwidth of the wanted signal according to the table 5.4.2.2-1 in TS 38.104 [2]. The aggregated wanted and interferer signal shall be centred in the BS channel bandwidth of the wanted signal.							



Table 7.9.5.1-3a: Local area BS in-channel selectivity for  $6.0 < f \leq 7.125$  GHz

BS channel bandwidth (MHz)	Subcarrier spacing (kHz)	Reference measurement channel (annex A.1)	Wanted signal mean power (dBm)	Interfering signal mean power (dBm)	Type of interfering signal
20, 30	15	G-FR1-A1-1	-86.9 - $\Delta_{\text{minSENS}}$	-68.4 - $\Delta_{\text{minSENS}}$	DFT-s-OFDM NR signal, 15 kHz SCS, 25 RBs
40, 50	15	G-FR1-A1-4	-80.5 - $\Delta_{\text{minSENS}}$	-62.4 - $\Delta_{\text{minSENS}}$	DFT-s-OFDM NR signal, 15 kHz SCS, 100 RBs
20, 30	30	G-FR1-A1-2	-87.0 - $\Delta_{\text{minSENS}}$	-69.4 - $\Delta_{\text{minSENS}}$	DFT-s-OFDM NR signal, 30 kHz SCS, 10 RBs
40, 50, 60, 70, 80, 90, 100	30	G-FR1-A1-5	-80.8 - $\Delta_{\text{minSENS}}$	-62.4 - $\Delta_{\text{minSENS}}$	DFT-s-OFDM NR signal, 30 kHz SCS, 50 RBs
20, 30	60	G-FR1-A1-9	-86.4 - $\Delta_{\text{minSENS}}$	-69.4 - $\Delta_{\text{minSENS}}$	DFT-s-OFDM NR signal, 60 kHz SCS, 5 RBs
40, 50, 60, 70, 80, 90, 100	60	G-FR1-A1-6	-80.9 - $\Delta_{\text{minSENS}}$	-62.6 - $\Delta_{\text{minSENS}}$	DFT-s-OFDM NR signal, 60 kHz SCS, 24 RBs

### 7.9.5.2 BS type 2-O

For *BS type 2-O*, the throughput shall be  $\geq 95\%$  of the maximum throughput of the reference measurement channel as specified in annex A.1 with parameters specified in tables 7.9.5.2-1, 7.9.5.2-2 and 7.9.5.2-3.

The wanted and interfering signals applies to each supported polarization, under the assumption of *polarization match*.

**Table 7.9.5.2-1: OTA in-channel selectivity requirement for *BS type 2-O* applicable in the frequency range 24.25 – 43.5 GHz**

BS channel bandwidth (MHz)	Subcarrier spacing (kHz)	Reference measurement channel (annex A.1)	Wanted signal mean power (dBm) (Note 2)	Interfering signal mean power (dBm) (Note 2)	Type of interfering signal
50	60	G-FR2-A1-4	$EIS_{\text{REFSENS}_{50\text{M}}} + 3.4 + \Delta_{\text{FR2\_REFSENS}}$	$EIS_{\text{REFSENS}_{50\text{M}}} + 10 + \Delta_{\text{FR2\_REFSENS}}$	DFT-s-OFDM NR signal, 60 kHz SCS, 32 RBs
100, 200	60	G-FR2-A1-1	$EIS_{\text{REFSENS}_{50\text{M}}} + 6.4 + \Delta_{\text{FR2\_REFSENS}}$	$EIS_{\text{REFSENS}_{50\text{M}}} + 13 + \Delta_{\text{FR2\_REFSENS}}$	DFT-s-OFDM NR signal, 60 kHz SCS, 64 RBs
50	120	G-FR2-A1-5	$EIS_{\text{REFSENS}_{50\text{M}}} + 3.4 + \Delta_{\text{FR2\_REFSENS}}$	$EIS_{\text{REFSENS}_{50\text{M}}} + 10 + \Delta_{\text{FR2\_REFSENS}}$	DFT-s-OFDM NR signal, 120 kHz SCS, 16 RBs
100, 200, 400	120	G-FR2-A1-2	$EIS_{\text{REFSENS}_{50\text{M}}} + 6.4 + \Delta_{\text{FR2\_REFSENS}}$	$EIS_{\text{REFSENS}_{50\text{M}}} + 13 + \Delta_{\text{FR2\_REFSENS}}$	DFT-s-OFDM NR signal, 120 kHz SCS, 32 RBs

NOTE 1: Wanted and interfering signal are placed adjacently around  $F_c$ , where the  $F_c$  is defined for *BS channel bandwidth* of the wanted signal according to the table 5.4.2.2-1 in TS 38.104 [2]. The aggregated wanted and interferer signal shall be centred in the BS channel bandwidth of the wanted signal.

NOTE 2:  $EIS_{\text{REFSENS}_{50\text{M}}}$  is defined in TS38.104 [2], clause 7.3.3.

**Table 7.9.5.2-2: OTA in-channel selectivity requirement for *BS type 2-O* applicable in the frequency range 43.5 – 48.2 GHz**

BS channel bandwidth (MHz)	Subcarrier spacing (kHz)	Reference measurement channel (annex A.1)	Wanted signal mean power (dBm) (Note 2)	Interfering signal mean power (dBm) (Note 2)	Type of interfering signal
50	60	G-FR2-A1-4	$EIS_{REFSENS\_50M} + 5.1 + \Delta_{FR2\_REFSENS}$	$EIS_{REFSENS\_50M} + 10 + \Delta_{FR2\_REFSENS}$	DFT-s-OFDM NR signal, 60 kHz SCS, 32 RBs
100, 200	60	G-FR2-A1-1	$EIS_{REFSENS\_50M} + 8.1 + \Delta_{FR2\_REFSENS}$	$EIS_{REFSENS\_50M} + 13 + \Delta_{FR2\_REFSENS}$	DFT-s-OFDM NR signal, 60 kHz SCS, 64 RBs
50	120	G-FR2-A1-5	$EIS_{REFSENS\_50M} + 5.1 + \Delta_{FR2\_REFSENS}$	$EIS_{REFSENS\_50M} + 10 + \Delta_{FR2\_REFSENS}$	DFT-s-OFDM NR signal, 120 kHz SCS, 16 RBs
100, 200, 400	120	G-FR2-A1-2	$EIS_{REFSENS\_50M} + 8.1 + \Delta_{FR2\_REFSENS}$	$EIS_{REFSENS\_50M} + 13 + \Delta_{FR2\_REFSENS}$	DFT-s-OFDM NR signal, 120 kHz SCS, 32 RBs

NOTE 1: Wanted and interfering signal are placed adjacently around  $F_c$ , where the  $F_c$  is defined for *BS channel bandwidth* of the wanted signal according to the table 5.4.2.2-1 in TS 38.104 [2]. The aggregated wanted and interferer signal shall be centred in the BS channel bandwidth of the wanted signal.

NOTE 2:  $EIS_{REFSENS\_50M}$  is defined in TS38.104 [2], clause 7.3.3.

**Table 7.9.5.2-3: OTA in-channel selectivity requirement for *BS type 2-O* applicable in the frequency range 52.6 – 71 GHz**

BS channel bandwidth (MHz)	Subcarrier spacing (kHz)	Reference measurement channel	Wanted signal mean power (dBm) (Note 2)	Interfering signal mean power (dBm) (Note 2)	Type of interfering signal
100, 400	120	G-FR2-A1-2	$EIS_{REFSENS\_50M} + 3 + 4.0 + \Delta_{FR2\_REFSENS}$	$EIS_{REFSENS\_50M} + 13 + \Delta_{FR2\_REFSENS}$	DFT-s-OFDM NR signal, 120 kHz SCS, 32 RB
400	480	G-FR2-A1-8	$EIS_{REFSENS\_50M} + 9 + 4.0 + \Delta_{FR2\_REFSENS}$	$EIS_{REFSENS\_50M} + 19 + \Delta_{FR2\_REFSENS}$	DFT-s-OFDM NR signal, 480 kHz SCS, 32 RB
800, 1600	480	G-FR2-A1-6	$EIS_{REFSENS\_50M} + 12 + 4.0 + \Delta_{FR2\_REFSENS}$	$EIS_{REFSENS\_50M} + 22 + \Delta_{FR2\_REFSENS}$	DFT-s-OFDM NR signal, 480 kHz SCS, 54 RB
400	960	G-FR2-A1-9	$EIS_{REFSENS\_50M} + 9 + 4.0 + \Delta_{FR2\_REFSENS}$	$EIS_{REFSENS\_50M} + 19 + \Delta_{FR2\_REFSENS}$	DFT-s-OFDM NR signal, 960 kHz SCS, 16 RB
800, 1600, 2000	960	G-FR2-A1-7	$EIS_{REFSENS\_50M} + 12 + 4.0 + \Delta_{FR2\_REFSENS}$	$EIS_{REFSENS\_50M} + 22 + \Delta_{FR2\_REFSENS}$	DFT-s-OFDM NR signal, 960 kHz SCS, 27 RB

NOTE 1: Wanted and interfering signal are placed adjacently around  $F_c$ , where the  $F_c$  is defined for *BS channel bandwidth* of the wanted signal according to the table 5.4.2.2-1 in TS 38.104 [2]. The aggregated wanted and interferer signal shall be centred in the BS channel bandwidth of the wanted signal.

NOTE 2:  $EIS_{REFSENS\_50M}$  is defined in TS 38.104 [2], clause 7.3.3.

## 8 Radiated performance requirements

### 8.1 General

#### 8.1.0 Scope and definitions

Radiated performance requirements specify the ability of the *BS type 1-O* or *BS type 2-O* to correctly demodulate radiated signals in various conditions and configurations. Radiated performance requirements are specified at the RIB.

Radiated performance requirements for the BS are specified for the fixed reference channels and propagation conditions defined in TS 38.104 [2] annex A and annex J, respectively. The requirements only apply to those FRCs that are supported by the BS.

The radiated performance requirements for *BS type 1-O* and for the *BS type 2-O* are limited to two OTA *demodulation branches* as described in clause 8.1.1. Conformance requirements can only be tested for 1 or 2 *demodulation branches* depending on the number of polarizations supported by the BS, with the required SNR applied separately per polarization.

NOTE 1: BS can support more than 2 *demodulation branches*, however OTA conformance testing can only be performed for 1 or 2 *demodulation branches*.

Unless stated otherwise, radiated performance requirements apply for a single carrier only. Radiated performance requirements for a BS supporting CA are defined in terms of single carrier requirements.

For *BS type 1-O* in FDD operation the requirements in clause 8 shall be met with the transmitter units associated with the RIB in the *operating band* turned ON.

NOTE 2: *BS type 1-O* in normal operating conditions in FDD operation is configured to transmit and receive at the same time. The transmitter unit(s) associated with the RIB may be OFF for some of the tests.

In tests performed with signal generators a synchronization signal may be provided between the BS and the signal generator, to enable correct timing of the wanted signal.

The SNR used in this clause is specified based on a single carrier and defined as:

$$\text{SNR} = S / N$$

Where:

S is the total signal energy in a slot on a RIB.

N is the noise energy in a bandwidth corresponding to the transmission bandwidth over the same duration where signal energy exists.

#### 8.1.1 OTA demodulation branches

Radiated performance requirements are only specified for up to 2 *demodulation branches*.

If the *BS type 1-O*, or the *BS type 2-O* uses polarization diversity and has the ability to maintain isolation between the signals for each of the *demodulation branches*, then radiated performance requirements can be tested for up to two *demodulation branches* (i.e. 1RX or 2RX test setups). When tested for two *demodulation branches*, each demodulation branch maps to one polarization.

If the *BS type 1-O*, or the *BS type 2-O* does not use polarization diversity then radiated performance requirements can only be tested for a single *demodulation branch* (i.e. 1RX test setup).

## 8.1.2 Applicability rule

### 8.1.2.0 General

Unless otherwise stated, for a BS declared to support more than 2 demodulation branches (for *BS type 1-O* and *BS type 2-O*), the performance requirement tests for 2 demodulation branches shall apply, and the mapping between connectors and demodulation branches is up to BS implementation.

The tests requiring more than [20] dB SNR level are set to N/A in the test requirements.

### 8.1.2.1 Applicability of PUSCH performance requirements

#### 8.1.2.1.1 Applicability of requirements for different subcarrier spacings

Unless otherwise stated, PUSCH requirement tests shall apply only for each subcarrier spacing declared to be supported (see D.7 in table 4.6-1).

Unless otherwise stated, PUSCH requirement tests with 30% of maximum throughput shall apply only for the lowest subcarrier spacing declared to be supported (see D.7 in table 4.6-1) for each frequency range.

#### 8.1.2.1.2 Applicability of requirements for different channel bandwidths

For each subcarrier spacing declared to be supported, the test requirements for a specific channel bandwidth shall apply only if the BS supports it (see D.7 in table 4.6-1).

Unless otherwise stated, for each subcarrier spacing declared to be supported, the tests shall be done only for the widest supported channel bandwidth. If performance requirement is not specified for this widest supported channel bandwidth, the tests shall be done by using performance requirement for the closest channel bandwidth lower than this widest supported bandwidth; the tested PRBs shall then be centered in this widest supported channel bandwidth.

#### 8.1.2.1.3 Applicability of requirements for different configurations

Unless otherwise stated, for *BS type 1-O*, PUSCH requirement tests shall apply only for the mapping type declared to be supported (see D.100 in table 4.6-1). If both mapping type A and type B are declared to be supported, the tests shall be done for either type A or type B; the same chosen mapping type shall then be used for all tests.

Unless otherwise stated, for *BS type 2-O*, PUSCH requirement tests shall apply only for the additional DM-RS position declared to be supported (see D.101 in table 4.6-1). If both options (i.e., pos0 and pos1) are declared to be supported, the tests shall be done for pos1.

Unless otherwise stated, for *BS type 2-O*, PUSCH requirement tests with transform precoding disabled shall apply for the PT-RS option declared to be supported (see D.106 in table 4.6-1). If both PT-RS options (without and with PT-RS) are declared to be supported, the tests shall be done for either without or with PT-RS only; the same chosen option shall then be used for all tests.

Unless otherwise stated, for *BS type 2-O*, PUSCH requirement tests with transform precoding enabled shall be done for without PT-RS.

#### 8.1.2.1.4 Applicability of requirements for uplink carrier aggregation

The tests for uplink carrier aggregation shall be carried out according to the declaration (see D.108 in table 4.6-1).

Unless otherwise stated, the tests for uplink carrier aggregation shall apply only for PUSCH with transform precoding disabled, and shall be conducted on per component carrier basis.

#### 8.1.2.1.5 Applicability of requirements for TDD with different UL-DL patterns

Unless otherwise stated, for each subcarrier spacing declared to be supported, if BS supports multiple TDD UL-DL patterns, only one of the supported TDD UL-DL patterns shall be used for all tests.

Note: For PUSCH Performance test cases, FRCs are not expected to be defined for the special slots, unless otherwise stated.

#### 8.1.2.1.6 Applicability of UL timing adjustment requirements for different scenarios

Unless otherwise stated, for *BS type 1-O*, the tests for UL timing adjustment for scenario Y and scenario Z shall apply only if high speed train is declared to be supported (see D.109 in table 4.6-1). A BS that passes the tests for scenario Y or scenario Z, can also consider the tests for scenario X passed.

Unless otherwise stated, for *BS type 2-O*, the tests for UL timing adjustment for scenario Y shall apply only if high speed train is declared to be supported (see D.109 in table 4.6-1).

#### 8.1.2.1.7 Applicability of 2-step RA type requirements for different subcarrier spacings

In 2-step RA type requirements, unless otherwise stated, MsgA PUSCH tests shall be done only for a BS declaring support of 2-step RA type (see D.115 in table 4.6-1) for one (freely selected) subcarrier spacing declared to be supported (see D.7 in table 4.6-1).

#### 8.1.2.1.8 Applicability of PUSCH with 0.001% BLER requirements

Unless otherwise stated, PUSCH with 0.001% BLER requirements shall apply only for a BS declaring support of low spectral efficiency MCS index table 3 (see D.123 in table 4.6-1).

#### 8.1.2.1.9 Applicability of PUSCH repetition type A requirements

Unless otherwise stated, PUSCH repetition type A requirements shall apply only for a BS declaring support of low spectral efficiency MCS index table 3 and PUSCH repetition type A (see D.123 and D.124 in table 4.6-1).

#### 8.1.2.1.10 Applicability of requirements with 256QAM

Unless otherwise stated, PUSCH with 256QAM requirements shall apply only for a BS declaring support of 256QAM (see D.116 in table 4.6-1).

#### 8.1.2.1.11 Applicability of PUSCH with enhanced DM-RS requirements

Unless otherwise stated, a BS declares to support PUSCH enhanced DM-RS type (see [D.127] in table 4.6-1) and pass the requirements defined in section 8.2.14, can also consider the tests defined in section 8.2.1 with same configurations except the DM-RS ports as passed.

### 8.1.2.2 Applicability of PUCCH performance requirements

#### 8.1.2.2.1 Applicability of requirements for different formats

Unless otherwise stated, PUCCH requirement tests shall apply only for each PUCCH format declared to be supported (see D.102 in table 4.6-1).

#### 8.1.2.2.2 Applicability of requirements for different subcarrier spacings

Unless otherwise stated, PUCCH requirement tests shall apply only for each subcarrier spacing declared to be supported (see D.7 in table 4.6-1).

#### 8.1.2.2.3 Applicability of requirements for different channel bandwidths

For each subcarrier spacing declared to be supported by the BS, the test requirements for a specific channel bandwidth shall apply only if the BS supports it (see D.7 in table 4.6-1).

Unless otherwise stated, for each subcarrier spacing declared to be supported, the tests shall be done only for the widest supported channel bandwidth. If performance requirement is not specified for this widest supported channel bandwidth, the tests shall be done by using performance requirement for the closest channel bandwidth lower than this widest supported bandwidth; the tested PRBs shall then be centered in this widest supported channel bandwidth.

For a BS declaring to support less than 5MHz (see D.14 in table 4.6-1) a UCI BLER performance test with Format 2 PUCCH shall be tested in 3 MHz. The UCI BLER performance tests on 5MHz PUCCH Format 2 to be skipped if applicable.

#### 8.1.2.2.4 Applicability of requirements for different configurations

Unless otherwise stated, PUCCH format 3 requirement tests shall apply only for the additional DM-RS configuration declared to be supported (see D.104 in table 4.6-1). If both options (without and with additional DM-RS) are declared to be supported, the tests shall be done for either without or with additional DM-RS; the same chosen option shall then be used for all tests.

Unless otherwise stated, PUCCH format 4 requirement tests shall apply only for the additional DM-RS configuration declared to be supported (see D.105 in table 4.6-1). If both options (without and with additional DM-RS) are declared to be supported, the tests shall be done for either without or with additional DM-RS; the same chosen option shall then be used for all tests.

#### 8.1.2.2.5 Applicability of requirements for multi-slot PUCCH

Unless otherwise stated, multi-slot PUCCH requirement tests shall apply only if the BS supports it (see D.107 in table 4.6-1).

#### 8.1.2.2.6 Applicability of requirements for PUCCH sub-slot based repetition

Unless otherwise stated, PUCCH sub-slot based repetition requirement tests shall apply only if the BS supports it (see D.118 in table 4.6-1).

### 8.1.2.3 Applicability of PRACH performance requirements

#### 8.1.2.3.1 Applicability of requirements for different formats

Unless otherwise stated, PRACH requirement tests shall apply only for each PRACH format declared to be supported (see D.103 in table 4.6-1).

Unless otherwise stated, PRACH requirement tests for high speed train shall apply only for each PRACH formats declared to be supported (see D.111 in table 4.6-1).

Unless otherwise stated, PRACH requirement tests for HAPS scenario shall apply only for each PRACH formats declared to be supported (see D.xxx in table 4.6-1).

#### 8.1.2.3.2 Applicability of requirements for different subcarrier spacings

Unless otherwise stated, for each PRACH format with short sequence declared to be supported, for each FR, the tests shall apply only for the smallest supported subcarrier spacing in the FR (see D.103 in table 4.6-1).

#### 8.1.2.3.3 Applicability of requirements for different channel bandwidths

Unless otherwise stated, for the subcarrier spacing to be tested, the test requirements shall apply only for anyone channel bandwidth declared to be supported (see D.7 in table 4.6-1).

Unless otherwise stated, for BS declaring to support less than 5MHz carrier bandwidth (see D.7 in table 4.6-1), only test requirements relating to RACH preamble formats with 15kHz SCS with sequence length LRA=139, and PRACH formats with 1.25kHz SCS with sequence length LRA=839 shall apply.

#### 8.1.2.3.4 Applicability of requirements for different restricted set types of long PRACH format 0

Unless otherwise stated, PRACH requirement tests for long PRACH preamble format 0 with restricted set Type A and B shall apply only for the restricted set type declared to be supported (see D.111 in table 4.6-1). If both restricted set

type A and type B are declared to be supported, the tests shall be done for type B; the same chosen mapping type shall then be used for all tests.

Unless otherwise stated, for BS declaring to support less than 5MHz carrier bandwidth (see D.7 in table 4.6-1), only test requirements relating to RACH preamble formats with 15kHz SCS with sequence length LRA=139, and PRACH formats with 1.25kHz SCS with sequence length LRA=839 shall apply.

#### 8.1.2.4 Applicability of PUSCH for high speed train performance requirements

##### 8.1.2.4.1 Applicability of requirements for different speeds

Unless otherwise stated, a *BS type 1-O* that declares to support 500 km/h (see D.110 in table 4.6-1) and passes the tests for 500 km/h, can also consider the tests for 350 km/h as passed.

##### 8.1.2.4.2 Applicability of requirements for 1T1R

In high speed train requirements, unless otherwise stated, for a BS supporting different numbers of TAB connectors for BS type 1-H (see D.37 in table 4.6-1), if the BS supports 1RX, the tests with low MIMO correlation level shall apply only for either one connector or the second lowest number of supported connectors, in addition to the highest numbers of supported connectors, and the specific connectors used for testing are based on manufacturer declaration.

If the BS doesn't support 1RX, the tests with low MIMO correlation level shall apply only for the lowest and highest numbers of supported connectors, and the specific connectors used for testing are based on manufacturer declaration.

NOTE: The highest number of connectors can simultaneously be second lowest number.

##### 8.1.2.4.3 Applicability of requirements for different channel bandwidths

For each subcarrier spacing declared to be supported, the test requirements for a specific channel bandwidth shall apply only if the BS supports it (see D.7 in table 4.6-1).

Unless otherwise stated, for each subcarrier spacing declared to be supported, the tests shall be done only for the widest supported channel bandwidth. If performance requirement is not specified for this widest supported channel bandwidth, the tests shall be done by using performance requirement for the closest channel bandwidth lower than this widest supported bandwidth; the tested PRBs shall then be centered in this widest supported channel bandwidth.

##### 8.1.2.4.4 Applicability of requirements for different DM-RS configurations

Unless otherwise stated, for *BS type 2-O*, FR2 HST PUSCH requirement test shall apply only for the additional DM-RS position declared to be supported (see D.117 in table 4.6-1). If more than one DM-RS configuration is declared to be supported, the test shall be done for the minimum number of DM-RS supported.

#### 8.1.2.5 Applicability of interlaced PUSCH performance requirements

##### 8.1.2.5.1 General applicability of interlaced PUSCH performance requirements

Interlaced PUSCH requirement tests shall apply only for a BS declaring support of interlaced formats (see D.112 in table 4.6-1).

##### 8.1.2.5.2 Applicability of requirements for different subcarrier spacings

Unless otherwise stated, PUSCH requirement tests shall apply only for each subcarrier spacing declared to be supported (see D.7 in table 4.6-1).

Unless otherwise stated, for each subcarrier-spacing declared to be supported for interlaced PUSCH, the tests shall apply only for the supported subcarrier spacing. If both 15 KHz and 30 KHz SCS are declared to be supported, the tests shall be done for 30 KHz SCS (see D.7 in table 4.6-1).

### 8.1.2.5.3 Applicability of requirements for different channel bandwidths

For each subcarrier spacing declared to be supported, the tests for a specific channel bandwidth shall apply only if the BS supports it (see D.7 in table 4.6-1).

Unless otherwise stated, for each subcarrier spacing declared to be supported, the tests shall be done only for the widest supported channel bandwidth. If performance requirement is not specified for this widest supported channel bandwidth, the tests shall be done by using performance requirement defined for 20 MHz channel bandwidth. For 15 KHz subcarrier spacing, the tested RB's are uniformly spaced over the channel bandwidth at RB index {110, 120, ...,210}. For 30 KHz subcarrier spacing, the tested RB's are uniformly spaced over the channel bandwidth at RB index {55, 60, ...,105}.

### 8.1.2.5.4 Applicability of requirements for different configurations

Unless otherwise stated, PUSCH requirement tests shall apply only for the mapping type declared to be supported (see D.100 in table 4.6-1). If both mapping type A and type B are declared to be supported, the tests shall be done for either type A or type B; the same chosen mapping type shall then be used for all tests.

### 8.1.2.5.5 Applicability of CG-UCI multiplexed on PUSCH requirements

Unless otherwise stated, interlaced CG-UCI multiplexed on interlaced PUSCH requirements shall apply only for a BS declaring support of CG-UCI (see D.114 in table 4.6-1).

## 8.1.2.6 Applicability of interlaced PUCCH performance requirements

### 8.1.2.6.1 General applicability of interlaced PUCCH performance requirements

Interlaced PUCCH requirement tests shall apply only for a BS declaring support of interlaced formats (see D.112 in table 4.6-1).

### 8.1.2.6.2 Applicability of requirements for different formats

Unless otherwise stated, interlaced PUCCH requirement tests shall apply only for each interlaced PUCCH format declared to be supported (see D.102 in table 4.6-1).

### 8.1.2.6.3 Applicability of requirements for different subcarrier spacings

Unless otherwise stated, PUCCH requirement tests shall apply only for each subcarrier spacing declared to be supported (see D.7 in table 4.6-1).

### 8.1.2.6.4 Applicability of requirements for different channel bandwidths

For each subcarrier spacing declared to be supported by the BS, the tests for a specific channel bandwidth shall apply only if the BS supports it (see D.7 in table 4.6-1).

Unless otherwise stated, for each subcarrier spacing declared to be supported, the tests shall be done only for the widest supported channel bandwidth. If performance requirement is not specified for this widest supported channel bandwidth, the tests shall be done by using performance requirement defined for 20 MHz channel bandwidth. For 15 KHz subcarrier spacing, the tested RB's are uniformly spaced over the channel bandwidth at RB index {110, 120, ...,210} for PUCCH formats 0, 1, and 2, and {110, 120, ...,200} for PUCCH format 3. For 30 KHz subcarrier spacing, the tested RB's are uniformly spaced over the channel bandwidth at RB index {55, 60, ...,105} for PUCCH formats 0, 1, and 2, and {55, 60, ...,100} for PUCCH format 3.

## 8.1.2.7 Applicability of performance requirements for PRACH with $L_{RA} = 1151$ and $L_{RA} = 571$

### 8.1.2.7.1 Applicability of requirements for different formats

Unless otherwise stated, PRACH requirement tests shall apply only for each PRACH format declared to be supported (see [D.113] in table 4.6-1).



#### 8.1.2.7.2 Applicability of requirements for different subcarrier spacings

Unless otherwise stated, for each PRACH format with  $L_{RA} = 1151$  and  $L_{RA} = 571$  declared to be supported, the tests shall apply only for the supported subcarrier spacing. If both 15 KHz and 30 KHz SCS are declared to be supported, the tests shall be done for 30 KHz SCS (see D.113 in table 4.6-1).

#### 8.1.2.7.3 Applicability of requirements for different channel bandwidths

Unless otherwise stated, for the subcarrier spacing to be tested, the tests shall apply only for anyone channel bandwidth declared to be supported (see D.7 in table 4.6-1).

#### 8.1.2.8 Applicability of performance requirements for PUSCH with TB over Multi-Slots

##### 8.1.2.8.1 Applicability of requirements for different UL-DL patterns

Unless otherwise stated, PUSCH with TB over multi-slots requirement tests shall apply only for UL-DL pattern characters declared to be supported (see D.119 and D.120 in table 4.6-1).

Unless otherwise stated, for each UL-DL pattern character declared to be supported, if BS supports multiple TDD UL-DL patterns, only one of the supported TDD UL-DL patterns shall be used for PUSCH with TB over multi-slots performance tests.

#### 8.1.2.9 Applicability of performance requirements for PUSCH with DM-RS bundling

##### 8.1.2.9.1 Applicability of requirements for TDD different subcarrier spacings

Unless otherwise stated, PUSCH with DM-RS bundling requirement tests shall apply only for each subcarrier spacing declared to be supported (see D.121 and D.122 in table 4.6-1).

##### 8.1.2.9.2 Applicability of requirements for TDD with different UL-DL patterns

Unless otherwise stated, for each subcarrier spacing declared to be supported, if BS supports multiple TDD UL-DL patterns, only one of the supported TDD UL-DL patterns with more than one consecutive UL slots shall be used for the PUSCH with DM-RS bundling performance tests.

##### 8.1.2.9.3 Applicability of requirements for different receiver antenna connectors

Unless otherwise stated, for a BS supporting different numbers of antenna connectors (for *BS type I-O*) (see D.37 in table 4.6-1), the PUSCH with DM-RS bundling performance tests with low MIMO correlation level shall apply only for the highest numbers of supported connectors, and the specific connectors used for testing are based on manufacturer declaration.

#### 8.1.2.10 Applicability of performance requirements for PUCCH with DM-RS bundling

##### 8.1.2.10.1 Applicability of requirements for TDD different subcarrier spacings

Unless otherwise stated, PUCCH with DM-RS bundling requirement tests shall apply only for each subcarrier spacing declared to be supported (see D.121 and D.122 in table 4.6-1).

##### 8.1.2.10.2 Applicability of requirements for TDD with different UL-DL patterns

Unless otherwise stated, for each subcarrier spacing declared to be supported, if BS supports multiple TDD UL-DL patterns, only one of the supported TDD UL-DL patterns with more than one consecutive UL slots shall be used for the PUCCH with DM-RS bundling performance tests.

### 8.1.2.11 Applicability of ATG PUSCH performance requirements

Unless otherwise stated, PUSCH requirement tests in clause 8.2.1, 8.2.2 and 8.2.3 with 1Tx test cases shall apply only for the BS declared to be supported (see D.125 in table 4.6-1).

Unless otherwise stated, PUSCH requirement tests in clause 8.2.14 shall apply only for the BS declared to be supported (see D.125 in table 4.6-1)

#### 8.1.2.11.1 Applicability of requirements for TDD with different UL-DL patterns

In ATG requirements, unless otherwise stated, for each subcarrier spacing declared to be supported, if BS supports multiple TDD UL-DL patterns including new TDD pattern (e.g., 30D4S6U) for ATG scenario, only one of the supported TDD UL-DL patterns shall be used for all tests.

#### 8.1.2.11.2 Applicability of requirements for different MCSs

In ATG requirements, Unless otherwise stated, PUSCH requirement tests with 256QAM in clause 8.2.14.5 shall apply only for the BS declared to be supported (see D.116 in table 4.6-1). A BS that declares to support 256QAM, and passes the test with 256QAM and the test with 64QAM in clause 8.2.1, the PUSCH requirement tests with 64QAM in clause 8.2.14.5 can be skipped.

### 8.1.2.12 Applicability of ATG PUCCH performance requirements

Unless otherwise stated, PUCCH requirement tests in clauses 8.3.1 to 8.3.6 shall apply only for the BS declared to be supported (see D.125 in table 4.6-1).

### 8.1.2.13 Applicability of ATG PRACH performance requirements

Unless otherwise stated, PRACH requirement tests in clauses 8.4.1.5 shall apply only for shall apply only for the BS declared to be supported (see D.125 in table 4.6-1).

### 8.1.2.14 Applicability of performance requirements for Multiple PRACH transmission

#### 8.1.2.14.1 Applicability of requirements for different formats

Unless otherwise stated, Multiple PRACH transmission requirements shall apply only for each PRACH format declared to be supported (see D.126 in table 4.6-1).

#### 8.1.2.14.2 Applicability of requirements for different channel bandwidths

Unless otherwise stated, for the subcarrier spacing to be tested, Multiple PRACH transmission requirements shall apply only for anyone channel bandwidth declared to be supported (see D.7 in table 4.6-1).

## 8.2 OTA performance requirements for PUSCH

### 8.2.1 Performance requirements for PUSCH with transform precoding disabled

#### 8.2.1.1 Definition and applicability

The performance requirement of PUSCH is determined by a minimum required throughput for a given SNR. The required throughput is expressed as a fraction of maximum throughput for the FRCs listed in annex A. The performance requirements assume HARQ re-transmissions.

Which specific test(s) are applicable to BS is based on the test applicability rules defined in clause 8.1.2.1.

### 8.2.1.2 Minimum Requirement

For *BS type 1-O*, the minimum requirement is in TS 38.104 [2], clause 11.2.1.1.

For *BS type 2-O*, the minimum requirement is in TS 38.104 [2], clause 11.2.2.1.

### 8.2.1.3 Test purpose

The test shall verify the receiver's ability to achieve throughput under multipath fading propagation conditions for a given SNR.

### 8.2.1.4 Method of test

#### 8.2.1.4.1 Initial conditions

Test environment: Normal, see annex B.2.

RF channels to be tested for single carrier:  $M$ , see clause 4.9.1.

RF channels to be tested for carrier aggregation:  $M_{\text{BW Channel CA}}$ ; see clause 4.9.1.

Direction to be tested: OTA REFSSENS *receiver target reference direction* (see D.54 in table 4.6-1).

#### 8.2.1.4.2 Procedure

- 1) Place the BS with its manufacturer declared coordinate system reference point in the same place as calibrated point in the test system, as shown in annex E.3.
- 2) Align the manufacturer declared coordinate system orientation of the BS with the test system.
- 3) Set the BS in the declared direction to be tested.
- 4) Connect the BS tester generating the wanted signal, multipath fading simulators and AWGN generators to a test antenna via a combining network in OTA test setup, as shown in annex E.3. Each of the demodulation branch signals should be transmitted on one polarization of the test antenna(s).
- 5) The characteristics of the wanted signal shall be configured according to the corresponding UL reference measurement channel defined in annex A, and according to additional test parameters listed in table 8.2.1.4.2-1.

Table 8.2.1.4.2-1: Test parameters for testing PUSCH

Parameter		BS type 1-O	BS type 2-O
Transform precoding		Disabled	
Default TDD UL-DL pattern (Note 1)		15 kHz SCS: 3D1S1U, S=10D:2G:2U 30 kHz SCS: 7D1S2U, S=6D:4G:4U	60 kHz and 120 kHz SCS: 3D1S1U, S=10D:2G:2U 480 kHz SCS:14D2S4U,S1=12D:2G 0U,S2=0D:6G:8U
HARQ	Maximum number of HARQ transmissions	4	
	RV sequence	0, 2, 3, 1	
DM-RS	DM-RS configuration type	1	
	DM-RS duration	single-symbol DM-RS	
	Additional DM-RS position	pos1	{pos0, pos1}
	Number of DM-RS CDM group(s) without data	2	
	Ratio of PUSCH EPRE to DM-RS EPRE	-3 dB	
	DM-RS port(s)	{0}, {0,1}	
	DM-RS sequence generation	$N_{ID}^0=0, n_{SCID}=0$	
Time domain resource assignment	PUSCH mapping type	A, B	B
	Start symbol	0	0
	Allocation length	14	10
Frequency domain resource assignment	RB assignment	Full applicable test bandwidth	
	Frequency hopping	Disabled	
TPMI index for 2Tx two layer spatial multiplexing transmission		0	
Code block group based PUSCH transmission		Disabled	
PTRS configuration	Frequency density ( $K_{PT-RS}$ )	N.A.	2, Disabled
	Time density ( $L_{PT-RS}$ )	N.A.	1, Disabled
Note 1: The same requirements are applicable to FDD and TDD with different UL-DL patterns for BS type 1-O, and the same requirements are applicable to TDD with different UL-DL patterns for BS type 2-O.			

- 6) The multipath fading emulators shall be configured according to the corresponding channel model defined in annex J.
- 7) Adjust the test signal mean power so the calibrated radiated SNR value at the BS receiver is as specified in clause 8.2.1.5.1 and 8.2.1.5.2 for *BS type 1-O* and *BS type 2-O* respectively, and that the SNR at the BS receiver is not impacted by the noise floor.

The power level for the transmission may be set such that the AWGN level at the RIB is equal to the AWGN level in table 8.2.1.4.2-2.

Table 8.2.1.4.2-2: AWGN power level at the BS input

BS type	Sub-carrier spacing (kHz)	Channel bandwidth (MHz)	AWGN power level
BS type 1-O (Note 4)	15	5	-86.5 - $\Delta_{\text{OTAREFSSENS}}$ dBm / 4.5 MHz
		10	-83.3 - $\Delta_{\text{OTAREFSSENS}}$ dBm / 9.36 MHz
		20	-80.2 - $\Delta_{\text{OTAREFSSENS}}$ dBm / 19.08 MHz
	30	10	-83.6 - $\Delta_{\text{OTAREFSSENS}}$ dBm / 8.64 MHz
		20	-80.4 - $\Delta_{\text{OTAREFSSENS}}$ dBm / 18.36 MHz
		40	-77.2 - $\Delta_{\text{OTAREFSSENS}}$ dBm / 38.16 MHz
		100	-73.1 - $\Delta_{\text{OTAREFSSENS}}$ dBm / 98.28 MHz
BS type 2-O (Note 5)	60	50	$\text{EIS}_{\text{REFSENS\_50M}} + \Delta_{\text{FR2\_REFSENS}} + 15$ dBm / 47.52 MHz
		100	$\text{EIS}_{\text{REFSENS\_50M}} + \Delta_{\text{FR2\_REFSENS}} + 18$ dBm / 95.04 MHz
	120	50	$\text{EIS}_{\text{REFSENS\_50M}} + \Delta_{\text{FR2\_REFSENS}} + 15$ dBm / 46.08 MHz
		100	$\text{EIS}_{\text{REFSENS\_50M}} + \Delta_{\text{FR2\_REFSENS}} + 18$ dBm / 95.04 MHz
		200	$\text{EIS}_{\text{REFSENS\_50M}} + \Delta_{\text{FR2\_REFSENS}} + 21$ dBm / 190.08 MHz
		400	$\text{EIS}_{\text{REFSENS\_50M}} + \Delta_{\text{FR2\_REFSENS}} + 24$ dBm / 380.16 MHz
	480	400	$\text{EIS}_{\text{REFSENS\_50M}} + \Delta_{\text{FR2\_REFSENS}} + 24$ dBm / 380.16 MHz
	<p>NOTE 1: <math>\Delta_{\text{OTAREFSSENS}}</math> as declared in D.53 in table 4.6-1 and clause 7.1.</p> <p>NOTE 2: <math>\Delta_{\text{FR2\_REFSENS}} = -3</math> dB as described in clause 7.1, since the OTA REFSSENS reference direction (as declared in D.54 in table 4.6-1) is used for testing.</p> <p>NOTE 3: <math>\text{EIS}_{\text{REFSENS\_50M}}</math> as declared in D.28 in table 4.6-1.</p> <p>NOTE 4: The AWGN power level contains an AWGN offset of 16dB by default. If needed for test purposes, the AWGN level can be reduced from the default by any value in the range 0dB to 16dB. Changing the AWGN level does not impact the validity of the test, as it reduces the effective base band SNR level.</p> <p>NOTE 5: The AWGN power level contains an AWGN offset of 15dB by default. If needed for test purposes, the AWGN level can be reduced from the default by any value in the range 0dB to 15dB. Changing the AWGN level does not impact the validity of the test, as it reduces the effective base band SNR level.</p>		

8) For reference channels applicable to the BS, measure the throughput.

## 8.2.1.5 Test Requirement

### 8.2.1.5.1 Test requirement for BS type 1-O

The throughput measured according to clause 8.2.1.4.2 shall not be below the limits for the SNR levels specified in table 8.2.1.5.1-1 to table 8.2.1.5.1-18 for 1Tx and for 2Tx two layer spatial multiplexing transmission.

**Table 8.2.1.5.1-1: Test requirements for PUSCH with 70% of maximum throughput, Type A, 5 MHz channel bandwidth, 15 kHz SCS**

Number of TX antennas	Number of demodulation branches	Cyclic prefix	Propagation conditions and correlation matrix (annex J)	Fraction of maximum throughput	FRC (annex A)	Additional DM-RS position	SNR (dB)
1	2	Normal	TDLB100-400 Low	70 %	G-FR1-A3-8	pos1	-1.7
		Normal	TDLC300-100 Low	70 %	G-FR1-A4-8	pos1	10.7
		Normal	TDLA30-10 Low	70 %	G-FR1-A5-8	pos1	12.9
		Normal	TDLA30-10 Low	70 %	G-FR1-A9-1	pos1	19.7
2	2	Normal	TDLB100-400 Low	70 %	G-FR1-A3-22	pos1	1.8
		Normal	TDLC300-100 Low	70 %	G-FR1-A4-22	pos1	19.0

**Table 8.2.1.5.1-2: Test requirements for PUSCH with 70% of maximum throughput, Type A, 10 MHz channel bandwidth, 15 kHz SCS**

Number of TX antennas	Number of demodulation branches	Cyclic prefix	Propagation conditions and correlation matrix (annex J)	Fraction of maximum throughput	FRC (annex A)	Additional DM-RS position	SNR (dB)
1	2	Normal	TDLB100-400 Low	70 %	G-FR1-A3-9	pos1	-1.9
		Normal	TDLC300-100 Low	70 %	G-FR1-A4-9	pos1	10.8
		Normal	TDLA30-10 Low	70 %	G-FR1-A5-9	pos1	12.8
		Normal	TDLA30-10 Low	70 %	G-FR1-A9-2	pos1	20.1
2	2	Normal	TDLB100-400 Low	70 %	G-FR1-A3-23	pos1	2.5
		Normal	TDLC300-100 Low	70 %	G-FR1-A4-23	pos1	19.1

**Table 8.2.1.5.1-3: Test requirements for PUSCH with 70% of maximum throughput, Type A, 20 MHz channel bandwidth, 15 kHz SCS**

Number of TX antennas	Number of demodulation branches	Cyclic prefix	Propagation conditions and correlation matrix (annex J)	Fraction of maximum throughput	FRC (annex A)	Additional DM-RS position	SNR (dB)
1	2	Normal	TDLB100-400 Low	70 %	G-FR1-A3-10	pos1	-1.5
		Normal	TDLC300-100 Low	70 %	G-FR1-A4-10	pos1	10.6
		Normal	TDLA30-10 Low	70 %	G-FR1-A5-10	pos1	13.0
2	2	Normal	TDLB100-400 Low	70 %	G-FR1-A3-24	pos1	2.9
		Normal	TDLC300-100 Low	70 %	G-FR1-A4-24	pos1	19.1

**Table 8.2.1.5.1-4: Test requirements for PUSCH with 70% of maximum throughput, Type A, 10 MHz channel bandwidth, 30 kHz SCS**

Number of TX antennas	Number of demodulation branches	Cyclic prefix	Propagation conditions and correlation matrix (annex J)	Fraction of maximum throughput	FRC (annex A)	Additional DM-RS position	SNR (dB)
1	2	Normal	TDLB100-400 Low	70 %	G-FR1-A3-11	pos1	-1.7
		Normal	TDLC300-100 Low	70 %	G-FR1-A4-11	pos1	10.8
		Normal	TDLA30-10 Low	70 %	G-FR1-A5-11	pos1	13.4
		Normal	TDLA30-10 Low	70 %	G-FR1-A9-3	pos1	19.9
2	2	Normal	TDLB100-400 Low	70 %	G-FR1-A3-25	pos1	2.1
		Normal	TDLC300-100 Low	70 %	G-FR1-A4-25	pos1	19.2

**Table 8.2.1.5.1-5: Test requirements for PUSCH with 70% of maximum throughput, Type A, 20 MHz channel bandwidth, 30 kHz SCS**

Number of TX antennas	Number of demodulation branches	Cyclic prefix	Propagation conditions and correlation matrix (annex J)	Fraction of maximum throughput	FRC (annex A)	Additional DM-RS position	SNR (dB)
1	2	Normal	TDLB100-400 Low	70 %	G-FR1-A3-12	pos1	-2.3
		Normal	TDLC300-100 Low	70 %	G-FR1-A4-12	pos1	10.8
		Normal	TDLA30-10 Low	70 %	G-FR1-A5-12	pos1	13.1
2	2	Normal	TDLB100-400 Low	70 %	G-FR1-A3-26	pos1	2.1
		Normal	TDLC300-100 Low	70 %	G-FR1-A4-26	pos1	18.9

**Table 8.2.1.5.1-6: Test requirements for PUSCH with 70% of maximum throughput, Type A, 40 MHz channel bandwidth, 30 kHz SCS**

Number of TX antennas	Number of demodulation branches	Cyclic prefix	Propagation conditions and correlation matrix (annex J)	Fraction of maximum throughput	FRC (annex A)	Additional DM-RS position	SNR (dB)
1	2	Normal	TDLB100-400 Low	70 %	G-FR1-A3-13	pos1	-1.9
		Normal	TDLC300-100 Low	70 %	G-FR1-A4-13	pos1	10.6
		Normal	TDLA30-10 Low	70 %	G-FR1-A5-13	pos1	13.0
		Normal	TDLA30-10 Low	70 %	G-FR1-A9-4	pos1	20.5
2	2	Normal	TDLB100-400 Low	70 %	G-FR1-A3-27	pos1	2.1
		Normal	TDLC300-100 Low	70 %	G-FR1-A4-27	pos1	20.3

**Table 8.2.1.5.1-7: Test requirements for PUSCH with 70% of maximum throughput, Type A, 100 MHz channel bandwidth, 30 kHz SCS**

Number of TX antennas	Number of demodulation branches	Cyclic prefix	Propagation conditions and correlation matrix (annex J)	Fraction of maximum throughput	FRC (annex A)	Additional DM-RS position	SNR (dB)
1	2	Normal	TDLB100-400 Low	70 %	G-FR1-A3-14	pos1	-2.2
		Normal	TDLC300-100 Low	70 %	G-FR1-A4-14	pos1	10.8
		Normal	TDLA30-10 Low	70 %	G-FR1-A5-14	pos1	13.6
		Normal	TDLA30-10 Low	70 %	G-FR1-A9-5	pos1	21.7
2	2	Normal	TDLB100-400 Low	70 %	G-FR1-A3-28	pos1	2.2
		Normal	TDLC300-100 Low	70 %	G-FR1-A4-28	pos1	20.0

**Table 8.2.1.5.1-8: Test requirements for PUSCH with 70% of maximum throughput, Type B, 5 MHz channel bandwidth, 15 kHz SCS**

Number of TX antennas	Number of demodulation branches	Cyclic prefix	Propagation conditions and correlation matrix (annex J)	Fraction of maximum throughput	FRC (annex A)	Additional DM-RS position	SNR (dB)
1	2	Normal	TDLB100-400 Low	70 %	G-FR1-A3-8	pos1	-1.7
		Normal	TDLC300-100 Low	70 %	G-FR1-A4-8	pos1	10.8
		Normal	TDLA30-10 Low	70 %	G-FR1-A5-8	pos1	13.1
		Normal	TDLA30-10 Low	70 %	G-FR1-A9-1	pos1	19.7
2	2	Normal	TDLB100-400 Low	70 %	G-FR1-A3-22	pos1	2.3
		Normal	TDLC300-100 Low	70 %	G-FR1-A4-22	pos1	19.1

**Table 8.2.1.5.1-9: Test requirements for PUSCH with 70% of maximum throughput, Type B, 10 MHz channel bandwidth, 15 kHz SCS**

Number of TX antennas	Number of demodulation branches	Cyclic prefix	Propagation conditions and correlation matrix (annex J)	Fraction of maximum throughput	FRC (annex A)	Additional DM-RS position	SNR (dB)
1	2	Normal	TDLB100-400 Low	70 %	G-FR1-A3-9	pos1	-1.7
		Normal	TDLC300-100 Low	70 %	G-FR1-A4-9	pos1	11.1
		Normal	TDLA30-10 Low	70 %	G-FR1-A5-9	pos1	13.2
		Normal	TDLA30-10 Low	70 %	G-FR1-A9-2	pos1	20.1
2	2	Normal	TDLB100-400 Low	70 %	G-FR1-A3-23	pos1	2.8
		Normal	TDLC300-100 Low	70 %	G-FR1-A4-23	pos1	19.5

**Table 8.2.1.5.1-10: Test requirements for PUSCH with 70% of maximum throughput, Type B, 20 MHz channel bandwidth, 15 kHz SCS**

Number of TX antennas	Number of demodulation branches	Cyclic prefix	Propagation conditions and correlation matrix (annex J)	Fraction of maximum throughput	FRC (annex A)	Additional DM-RS position	SNR (dB)
1	2	Normal	TDLB100-400 Low	70 %	G-FR1-A3-10	pos1	-1.5
		Normal	TDLC300-100 Low	70 %	G-FR1-A4-10	pos1	11.0
		Normal	TDLA30-10 Low	70 %	G-FR1-A5-10	pos1	12.9
2	2	Normal	TDLB100-400 Low	70 %	G-FR1-A3-24	pos1	2.4
		Normal	TDLC300-100 Low	70 %	G-FR1-A4-24	pos1	18.9

**Table 8.2.1.5.1-11: Test requirements for PUSCH with 70% of maximum throughput, Type B, 10 MHz channel bandwidth, 30 kHz SCS**

Number of TX antennas	Number of demodulation branches	Cyclic prefix	Propagation conditions and correlation matrix (annex J)	Fraction of maximum throughput	FRC (annex A)	Additional DM-RS position	SNR (dB)
1	2	Normal	TDLB100-400 Low	70 %	G-FR1-A3-11	pos1	-1.8
		Normal	TDLC300-100 Low	70 %	G-FR1-A4-11	pos1	10.7
		Normal	TDLA30-10 Low	70 %	G-FR1-A5-11	pos1	13.1
		Normal	TDLA30-10 Low	70 %	G-FR1-A9-3	pos1	19.8
2	2	Normal	TDLB100-400 Low	70 %	G-FR1-A3-25	pos1	1.9
		Normal	TDLC300-100 Low	70 %	G-FR1-A4-25	pos1	19.3

**Table 8.2.1.5.1-12: Test requirements for PUSCH with 70% of maximum throughput, Type B, 20 MHz channel bandwidth, 30 kHz SCS**

Number of TX antennas	Number of demodulation branches	Cyclic prefix	Propagation conditions and correlation matrix (annex J)	Fraction of maximum throughput	FRC (annex A)	Additional DM-RS position	SNR (dB)
1	2	Normal	TDLB100-400 Low	70 %	G-FR1-A3-12	pos1	-2.3
		Normal	TDLC300-100 Low	70 %	G-FR1-A4-12	pos1	10.7
		Normal	TDLA30-10 Low	70 %	G-FR1-A5-12	pos1	13.1
2	2	Normal	TDLB100-400 Low	70 %	G-FR1-A3-26	pos1	2.1
		Normal	TDLC300-100 Low	70 %	G-FR1-A4-26	pos1	19.0



**Table 8.2.1.5.1-13: Test requirements for PUSCH with 70% of maximum throughput, Type B, 40 MHz channel bandwidth, 30 kHz SCS**

Number of TX antennas	Number of demodulation branches	Cyclic prefix	Propagation conditions and correlation matrix (annex J)	Fraction of maximum throughput	FRC (annex A)	Additional DM-RS position	SNR (dB)
1	2	Normal	TDLB100-400 Low	70 %	G-FR1-A3-13	pos1	-1.9
		Normal	TDLC300-100 Low	70 %	G-FR1-A4-13	pos1	10.6
		Normal	TDLA30-10 Low	70 %	G-FR1-A5-13	pos1	13.1
		Normal	TDLA30-10 Low	70 %	G-FR1-A9-4	pos1	20.5
2	2	Normal	TDLB100-400 Low	70 %	G-FR1-A3-27	pos1	2.5
		Normal	TDLC300-100 Low	70 %	G-FR1-A4-27	pos1	19.5

**Table 8.2.1.5.1-14: Test requirements for PUSCH with 70% of maximum throughput, Type B, 100 MHz channel bandwidth, 30 kHz SCS**

Number of TX antennas	Number of demodulation branches	Cyclic prefix	Propagation conditions and correlation matrix (annex J)	Fraction of maximum throughput	FRC (annex A)	Additional DM-RS position	SNR (dB)
1	2	Normal	TDLB100-400 Low	70 %	G-FR1-A3-14	pos1	-1.9
		Normal	TDLC300-100 Low	70 %	G-FR1-A4-14	pos1	10.7
		Normal	TDLA30-10 Low	70 %	G-FR1-A5-14	pos1	13.7
		Normal	TDLA30-10 Low	70 %	G-FR1-A9-5	pos1	21.7
2	2	Normal	TDLB100-400 Low	70 %	G-FR1-A3-28	pos1	2.4
		Normal	TDLC300-100 Low	70 %	G-FR1-A4-28	pos1	20.1

**Table 8.2.1.5.1-15: Test requirements for PUSCH with 30% of maximum throughput, Type A, 5 MHz channel bandwidth, 15 kHz SCS**

Number of TX antennas	Number of demodulation branches	Cyclic prefix	Propagation conditions and correlation matrix (Annex J)	Fraction of maximum throughput	FRC (Annex A)	Additional DM-RS position	SNR (dB)
1	2	Normal	TDLC300-100 Low	30 %	G-FR1-A4-8	pos1	3.5

**Table 8.2.1.5.1-16: Test requirements for PUSCH with 30% of maximum throughput, Type A, 10 MHz channel bandwidth, 30 kHz SCS**

Number of TX antennas	Number of demodulation branches	Cyclic prefix	Propagation conditions and correlation matrix (Annex J)	Fraction of maximum throughput	FRC (Annex A)	Additional DM-RS position	SNR (dB)
1	2	Normal	TDLC300-100 Low	30 %	G-FR1-A4-11	pos1	3.4

**Table 8.2.1.5.1-17: Test requirements for PUSCH with 30% of maximum throughput, Type B, 5 MHz channel bandwidth, 15 kHz SCS**

Number of TX antennas	Number of demodulation branches	Cyclic prefix	Propagation conditions and correlation matrix (Annex J)	Fraction of maximum throughput	FRC (Annex A)	Additional DM-RS position	SNR (dB)
1	2	Normal	TDLC300-100 Low	30 %	G-FR1-A4-8	pos1	3.4

**Table 8.2.1.5.1-18: Test requirements for PUSCH with 30% of maximum throughput, Type B, 10 MHz channel bandwidth, 30 kHz SCS**

Number of TX antennas	Number of demodulation branches	Cyclic prefix	Propagation conditions and correlation matrix (Annex J)	Fraction of maximum throughput	FRC (Annex A)	Additional DM-RS position	SNR (dB)
1	2	Normal	TDLC300-100 Low	30 %	G-FR1-A4-11	pos1	3.5

NOTE: If the above Test Requirement differs from the Minimum Requirement then the Test Tolerance applied for this test is non-zero. The Test Tolerance for this test and the explanation of how the Minimum Requirement has been relaxed by the Test Tolerance is given in annex C.

**8.2.1.5.2 Test requirement for BS type 2-0**

The throughput measured according to clause 8.2.1.4.2 shall not be below the limits for the SNR levels specified in table 8.2.1.5.2-1 to 8.2.1.5.2-10.

**Table 8.2.1.5.2-1: Test requirements for PUSCH with 70% of maximum throughput, 50 MHz Channel Bandwidth, 60 kHz SCS in FR2-1**

Number of TX antennas	Number of demodulation branches	Cyclic prefix	Propagation conditions and correlation matrix (annex J)	Fraction of maximum throughput	FRC (annex A)	Additional DM-RS position	PT-RS	SNR (dB)
1	2	Normal	TDLA30-300 Low	70 %	G-FR2-A3-1	pos0	No	-1.4
					G-FR2-A3-13	pos1	No	-1.6
		Normal	TDLA30-300 Low	70 %	G-FR2-A4-1	pos0	Yes	12.6
							No	12.1
					G-FR2-A4-11	pos1	Yes	11.3
							No	11.3
		Normal	TDLA30-75 Low	70 %	G-FR2-A5-1	pos0	Yes	14.3
							No	13.7
		G-FR2-A5-6	pos1	Yes	14.0			
				No	13.5			
		Normal	TDLD30-35 Low	70 %	G-FR2-A9-3	pos0	Yes	[20.4] <sup>Note1</sup>
							No	[20.0]
G-FR2-A9-6	pos1	Yes	[20.4] <sup>Note1</sup>					
		No	[19.8]					
2		Normal	TDLA30-300 Low	70 %	G-FR2-A3-6	pos0	No	2.3
					G-FR2-A3-18	pos1	No	2.0
		Normal	TDLA30-300 Low	70 %	G-FR2-A7-1	pos0	Yes	16.0
							No	15.1
					G-FR2-A7-6	pos1	Yes	14.6
No	13.8							

Note 1: The AWGN level is reduced from the default by any value in the range max (0, SNR-20dB) to 15dB. Changing the AWGN level does not impact the validity of the test, as it reduces the effective base band SNR level.

**Table 8.2.1.5.2-2: Test requirements for PUSCH with 70% of maximum throughput, 100 MHz Channel Bandwidth, 60 kHz SCS in FR2-1**

Number of TX antennas	Number of demodulation branches	Cyclic prefix	Propagation conditions and correlation matrix (annex J)	Fraction of maximum throughput	FRC (annex A)	Additional DM-RS position	PT-RS	SNR (dB)
1	2	Normal	TDLA30-300 Low	70 %	G-FR2-A3-2	pos0	No	-1.5
					G-FR2-A3-14	pos1	No	-1.8
		Normal	TDLA30-300 Low	70 %	G-FR2-A4-2	pos0	Yes	12.8
							No	11.8
					G-FR2-A4-12	pos1	Yes	11.8
							No	11.2
		Normal	TDLA30-75 Low	70 %	G-FR2-A5-2	pos0	Yes	14.8
							No	13.9
					G-FR2-A5-7	pos1	Yes	14.3
							No	13.7
2		Normal	TDLA30-300 Low	70 %	G-FR2-A3-7	pos0	No	2.3
					G-FR2-A3-19	pos1	No	2.0
		Normal	TDLA30-300 Low	70 %	G-FR2-A7-2	pos0	Yes	16.8
							No	15.7
					G-FR2-A7-7	pos1	Yes	14.6
							No	13.9

**Table 8.2.1.5.2-3: Test requirements for PUSCH with 70% of maximum throughput, 50 MHz Channel Bandwidth, 120 kHz SCS in FR2-1**

Number of TX antennas	Number of demodulation branches	Cyclic prefix	Propagation conditions and correlation matrix (annex J)	Fraction of maximum throughput	FRC (annex A)	Additional DM-RS position	PT-RS	SNR (dB)		
1	2	Normal	TDLA30-300 Low	70 %	G-FR2-A3-3	pos0	No	-1.2		
					G-FR2-A3-15	pos1	No	-1.5		
		Normal	TDLA30-300 Low	70 %	G-FR2-A4-3	pos0	Yes	12.2		
							No	11.5		
					G-FR2-A4-13	pos1	Yes	11.5		
							No	11.1		
		Normal	TDLA30-75 Low	70 %	G-FR2-A5-3	pos0	Yes	14.3		
							No	13.7		
					G-FR2-A5-8	pos1	Yes	13.8		
							No	13.6		
		Normal	TDLD30-35 Low	70 %	G-FR2-A9-1	pos0	Yes	20.6Note1		
							No	19.9		
					G-FR2-A9-4	pos1	Yes	20.3Note1		
							No	19.5		
		2		Normal	TDLA30-300 Low	70 %	G-FR2-A3-8	pos0	No	2.2
							G-FR2-A3-20	pos1	No	2.1
Normal	TDLA30-300 Low			70 %	G-FR2-A7-3	pos0	Yes	15.0		
							No	14.4		
					G-FR2-A7-8	Pos1	Yes	14.7		
							No	13.9		

Note 1: The AWGN level is reduced from the default by any value in the range max (0, SNR-20dB) to 15dB. Changing the AWGN level does not impact the validity of the test, as it reduces the effective base band SNR level.

**Table 8.2.1.5.2-4: Test requirements for PUSCH with 70% of maximum throughput, 100 MHz Channel Bandwidth, 120 kHz SCS in FR2-1**

Number of TX antennas	Number of demodulation branches	Cyclic prefix	Propagation conditions and correlation matrix (annex J)	Fraction of maximum throughput	FRC (annex A)	Additional DM-RS position	PT-RS	SNR (dB)
1	2	Normal	TDLA30-300 Low	70 %	G-FR2-A3-4	pos0	No	-1.8
					G-FR2-A3-16	pos1	No	-1.9
		Normal	TDLA30-300 Low	70 %	G-FR2-A4-4	pos0	Yes	12.5
						No	11.1	
					G-FR2-A4-14	pos1	Yes	11.7
						No	11.1	
		Normal	TDLA30-75 Low	70 %	G-FR2-A5-4	pos0	Yes	14.1
						No	13.5	
					G-FR2-A5-9	pos1	Yes	14.0
						No	13.4	
2	2	Normal	TDLA30-300 Low	70 %	G-FR2-A3-9	pos0	No	2.2
					G-FR2-A3-21	pos1	No	2.0
		Normal	TDLA30-300 Low	70 %	G-FR2-A7-4	pos0	Yes	14.7
						No	14.0	
					G-FR2-A7-9	pos1	Yes	14.3
						No	13.7	

**Table 8.2.1.5.2-5: Test requirements for PUSCH with 70% of maximum throughput, 200 MHz Channel Bandwidth, 120 kHz SCS in FR2-1**

Number of TX antennas	Number of demodulation branches	Cyclic prefix	Propagation conditions and correlation matrix (annex J)	Fraction of maximum throughput	FRC (annex A)	Additional DM-RS position	PT-RS	SNR (dB)
1	2	Normal	TDLA30-300 Low	70 %	G-FR2-A3-5	pos0	No	-1.5
					G-FR2-A3-17	pos1	No	-1.8
		Normal	TDLA30-300 Low	70 %	G-FR2-A4-5	pos0	Yes	11.9
						No	11.5	
					G-FR2-A4-15	pos1	Yes	11.8
						No	11.3	
		Normal	TDLA30-75 Low	70 %	G-FR2-A5-5	pos0	Yes	14.7
						No	14.0	
					G-FR2-A5-10	pos1	Yes	14.3
						No	13.9	
		Normal	TDLD30-35 Low	70 %	G-FR2-A9-2	pos0	Yes	20.5Note1
						No	20.1Note1	
					G-FR2-A9-5	pos1	Yes	20.4Note1
						No	19.9	
2	2	Normal	TDLA30-300 Low	70 %	G-FR2-A3-10	pos0	No	2.2
					G-FR2-A3-22	pos1	No	1.9
		Normal	TDLA30-300 Low	70 %	G-FR2-A7-5	pos0	Yes	14.8
						No	14.1	
					G-FR2-A7-10	pos1	Yes	14.4
						No	13.8	

Note 1: The AWGN level is reduced from the default by any value in the range max (0, SNR-20dB) to 15dB. Changing the AWGN level does not impact the validity of the test, as it reduces the effective base band SNR level.

**Table 8.2.1.5.2-6: Test requirements for PUSCH with 30% of maximum throughput, 50 MHz channel bandwidth, 60 kHz SCS in FR2-1**

Number of TX antennas	Number of demodulation branches	Cyclic prefix	Propagation conditions and correlation matrix (annex J)	Fraction of maximum throughput	FRC (annex A)	Additional DM-RS position	PT-RS	SNR (dB)
1	2	Normal	TDLA30-300 Low	30 %	G-FR2-A4-1	pos0	Yes	4.6
							No	4.1
					G-FR2-A4-11	pos1	Yes	4.3
							No	3.7

**Table 8.2.1.5.2-7: Test requirements for PUSCH with 30% of maximum throughput, 50 MHz channel bandwidth, 120 kHz SCS in FR2-1**

Number of TX antennas	Number of demodulation branches	Cyclic prefix	Propagation conditions and correlation matrix (annex J)	Fraction of maximum throughput	FRC (annex A)	Additional DM-RS position	PT-RS	SNR (dB)
1	2	Normal	TDLA30-300 Low	30 %	G-FR2-A4-3	pos0	Yes	4.6
							No	4.2
					G-FR2-A4-13	pos1	Yes	4.3
							No	3.8

**Table 8.2.1.5.2-8: Test requirements for PUSCH with 70% of maximum throughput, 100 MHz Channel Bandwidth, 120 kHz SCS in FR2-2**

Number of TX antennas	Number of demodulation branches	Cyclic prefix	Propagation conditions and correlation matrix (annex J)	Fraction of maximum throughput	FRC (annex A)	Additional DM-RS position	PT-RS	SNR (dB)
1	2	Normal	TDLA30-650	70 %	G-FR2-A3B-3	pos1	No	0.4
		Normal	TDLA30-650	70 %	G-FR2-A4-21	pos1	Yes	11.8
		Normal	TDLD30-200	70 %	G-FR2-A5-11	pos1	Yes	13.1
2		Normal	TDLA30-650	70 %	G-FR2-A3B-8	pos1	No	4.5
		Normal	TDLA30-650	70 %	G-FR2-A7-11	pos1	Yes	14.2

**Table 8.2.1.5.2-9: Test requirements for PUSCH with 70% of maximum throughput, 400 MHz Channel Bandwidth, 120 kHz SCS in FR2-2**

Number of TX antennas	Number of demodulation branches	Cyclic prefix	Propagation conditions and correlation matrix (annex J)	Fraction of maximum throughput	FRC (annex A)	Additional DM-RS position	PT-RS	SNR (dB)
1	2	Normal	TDLA10-650	70 %	G-FR2-A3B-4	pos1	No	0.4
		Normal	TDLA10-650	70 %	G-FR2-A4-22	pos1	Yes	11.8
		Normal	TDLD10-200	70 %	G-FR2-A5-12	pos1	Yes	13.2
2		Normal	TDLA10-650	70 %	G-FR2-A3B-9	pos1	No	4.6
		Normal	TDLA10-650	70 %	G-FR2-A7-12	pos1	Yes	14.6

**Table 8.2.1.5.2-10: Test requirements for PUSCH with 70% of maximum throughput, 400 MHz Channel Bandwidth, 480 kHz SCS in FR2-2**

Number of TX antennas	Number of demodulation branches	Cyclic prefix	Propagation conditions and correlation matrix (annex J)	Fraction of maximum throughput	FRC (annex A)	Additional DM-RS position	PT-RS	SNR (dB)
1	2	Normal	TDLA10-650	70 %	G-FR2-A3B-5	pos1	No	0.1
		Normal	TDLA10-650	70 %	G-FR2-A4-23	pos1	Yes	11.4
		Normal	TDLD10-200	70 %	G-FR2-A5-13	pos1	Yes	13.4
2		Normal	TDLA10-650	70 %	G-FR2-A3B-10	pos1	No	4.0
		Normal	TDLA10-650	70 %	G-FR2-A7-13	pos1	Yes	13.8

NOTE: If the above Test Requirement differs from the Minimum Requirement then the Test Tolerance applied for this test is non-zero. The Test Tolerance for this test and the explanation of how the Minimum Requirement has been relaxed by the Test Tolerance is given in annex C.

## 8.2.2 Performance requirements for PUSCH with transform precoding enabled

### 8.2.2.1 Definition and applicability

The performance requirement of PUSCH is determined by a minimum required throughput for a given SNR. The required throughput is expressed as a fraction of maximum throughput for the FRCs listed in annex A. The performance requirements assume HARQ re-transmissions.

Which specific test(s) are applicable to BS is based on the test applicability rules defined in clause 8.1.2.

### 8.2.2.2 Minimum Requirement

For *BS type 1-O*, the minimum requirement is in TS 38.104 [2], clause 11.2.1.2.

For *BS type 2-O*, the minimum requirement is in TS 38.104 [2], clause 11.2.2.2.

### 8.2.2.3 Test Purpose

The test shall verify the receiver's ability to achieve throughput under multipath fading propagation conditions for a given SNR.

### 8.2.2.4 Method of test

#### 8.2.2.4.1 Initial Conditions

Test environment: Normal, see clause B.2.

RF channels to be tested for single carrier: M, see clause 4.9.1.

Direction to be tested: OTA REFSENS *receiver target reference direction* (see D.54 in table 4.6-1).

#### 8.2.2.4.2 Procedure

- 1) Place the BS with its manufacturer declared coordinate system reference point in the same place as calibrated point in the test system, as shown in annex E.3.
- 2) Align the manufacturer declared coordinate system orientation of the BS with the test system.

- 3) Set the BS in the declared direction to be tested.
- 4) Connect the BS tester generating the wanted signal, multipath fading simulators and AWGN generators to a test antenna via a combining network in OTA test setup, as shown in annex E.3. Each of the demodulation branch signals should be transmitted on one polarization of the test antenna(s).
- 5) The characteristics of the wanted signal shall be configured according to the corresponding UL reference measurement channel defined in annex A, and according to additional test parameters listed in table 8.2.2.4.2-1.

**Table 8.2.2.4.2-1: Test parameters for testing PUSCH**

Parameter		BS type 1-O	BS type 2-O
Transform precoding		Enabled	
Default TDD UL-DL pattern (Note 1)		15 kHz SCS: 3D1S1U, S=10D:2G:2U 30 kHz SCS: 7D1S2U, S=6D:4G:4U	60 kHz and 120 KHz SCS: 3D1S1U, S=10D:2G:2U 480 KHz SCS:14D2S4U,S1=12D:2G 0U,S2=0D:6G:8U
HARQ	Maximum number of HARQ transmissions	4	
	RV sequence	0, 2, 3, 1	
DM-RS	DM-RS configuration type	1	
	DM-RS duration	single-symbol DM-RS	
	Additional DM-RS position	pos1	pos0, pos1
	Number of DM-RS CDM group(s) without data	2	
	Ratio of PUSCH EPRE to DM-RS EPRE	-3 dB	
	DM-RS port(s)	0	
DM-RS sequence generation		$N_{ID}^0=0$ , group hopping and sequence hopping are disabled	
Time domain resource assignment	PUSCH mapping type	A, B	B
	Start symbol	0	0
	Allocation length	14	10
Frequency domain resource assignment	RB assignment	15 kHz SCS: 25 PRBs in the middle of the test bandwidth 30 kHz SCS: 24 PRBs in the middle of the test bandwidth	FR2-1: 30 PRBs in the middle of the test bandwidth FR2-2: 64 PRBs in the middle of the test bandwidth
	Frequency hopping	Disabled	
Code block group based PUSCH transmission		Disabled	
PT-RS		Not configured	
NOTE 1: The same requirements are applicable to FDD and TDD with different UL-DL patterns for BS type 1-O, and the same requirements are applicable to TDD with different UL-DL patterns for BS type 2-O.			

- 6) The multipath fading emulators shall be configured according to the corresponding channel model defined in annex J.
- 7) Adjust the test signal mean power so the calibrated radiated SNR value at the BS receiver is as specified in clause 8.2.2.5.1 and 8.2.2.5.2 for *BS type 1-O* and *BS type 2-O* respectively, and that the SNR at the BS receiver is not impacted by the noise floor.

The power level for the transmission may be set such that the AWGN level at the RIB is equal to the AWGN level in table 8.2.2.4.2-2.

Table 8.2.2.4.2-2: AWGN power level at the BS input

BS type	Sub-carrier spacing (kHz)	Channel bandwidth (MHz)	AWGN power level
BS type 1-O (Note 4)	15	5	-86.5 - $\Delta_{OTAREFSENS}$ dBm / 4.5 MHz
	30	10	-83.6 - $\Delta_{OTAREFSENS}$ dBm / 8.64 MHz
BS type 2-O (Note 5)	60	50	$EIS_{REFSENS\_50M} + \Delta_{FR2\_REFSENS} + 15$ dBm / 47.52MHz
	120	50	$EIS_{REFSENS\_50M} + \Delta_{FR2\_REFSENS} + 15$ dBm / 46.08 MHz
		100	$EIS_{REFSENS\_50M} + \Delta_{FR2\_REFSENS} + 24$ dBm / 380.16 MHz
480	400	$EIS_{REFSENS\_50M} + \Delta_{FR2\_REFSENS} + 24$ dBm / 380.16 MHz	

NOTE 1:  $\Delta_{OTAREFSENS}$  as declared in D.53 in table 4.6-1 and clause 7.1.  
NOTE 2:  $\Delta_{FR2\_REFSENS} = -3$  dB as described in clause 7.1, since the OTA REFSSENS reference direction (as declared in D.54 in table 4.6-1) is used for testing.  
NOTE 3:  $EIS_{REFSENS\_50M}$  as declared in D.28 in table 4.6-1.  
NOTE 4: The AWGN power level contains an AWGN offset of 16dB by default. If needed for test purposes, the AWGN level can be reduced from the default by any value in the range 0dB to 16dB. Changing the AWGN level does not impact the validity of the test, as it reduces the effective base band SNR level.  
NOTE 5: The AWGN power level contains an AWGN offset of 15dB by default. If needed for test purposes, the AWGN level can be reduced from the default by any value in the range 0dB to 15dB. Changing the AWGN level does not impact the validity of the test, as it reduces the effective base band SNR level.

8) For reference channels applicable to the BS, measure the throughput.

## 8.2.2.5 Test Requirement

### 8.2.2.5.1 Test requirement for BS type 1-O

The throughput measured according to clause 8.2.2.4.2 shall not be below the limits for the SNR levels specified in table 8.2.2.5.1-1 to table 8.2.2.5.1-4.

**Table 8.2.2.5.1-1: Test requirements for PUSCH with 70% of maximum throughput, Type A, 5 MHz channel bandwidth, 15 kHz SCS in FR2-1**

Number of TX antennas	Number of demodulation branches	Cyclic prefix	Propagation conditions and correlation matrix (annex J)	Fraction of maximum throughput	FRC (annex A)	Additional DM-RS position	SNR (dB)
1	2	Normal	TDLB100-400 Low	70 %	G-FR1-A3-31	pos1	-1.8

**Table 8.2.2.5.1-2: Test requirements for PUSCH with 70% of maximum throughput, Type A, 10 MHz channel bandwidth, 30 kHz SCS in FR2-1**

Number of TX antennas	Number of demodulation branches	Cyclic prefix	Propagation conditions and correlation matrix (annex J)	Fraction of maximum throughput	FRC (annex A)	Additional DM-RS position	SNR (dB)
1	2	Normal	TDLB100-400 Low	70 %	G-FR1-A3-32	pos1	-1.9



**Table 8.2.2.5.1-3: Test requirements for PUSCH with 70% of maximum throughput, Type B, 5 MHz channel bandwidth, 15 kHz SCS in FR2-1**

Number of TX antennas	Number of demodulation branches	Cyclic prefix	Propagation conditions and correlation matrix (annex J)	Fraction of maximum throughput	FRC (annex A)	Additional DM-RS position	SNR (dB)
1	2	Normal	TDLB100-400 Low	70 %	G-FR1-A3-31	pos1	-1.7

**Table 8.2.2.5.1-4: Test requirements for PUSCH with 70% of maximum throughput, Type B, 10 MHz channel bandwidth, 30 kHz SCS in FR2-1**

Number of TX antennas	Number of demodulation branches	Cyclic prefix	Propagation conditions and correlation matrix (annex J)	Fraction of maximum throughput	FRC (annex A)	Additional DM-RS position	SNR (dB)
1	2	Normal	TDLB100-400 Low	70 %	G-FR1-A3-32	pos1	-2.1

#### 8.2.2.5.2 Test requirement for *BS type 2-O*

The throughput measured according to clause 8.2.2.4.2 shall not be below the limits for the SNR levels specified in table 8.2.2.5.2-1 to table 8.2.2.5.2-2.

**Table 8.2.2.5.2-1: Test requirements for PUSCH with 70% of maximum throughput, Type B, 50 MHz channel bandwidth, 60 kHz SCS in FR2-1**

Number of TX antennas	Number of demodulation branches	Cyclic prefix	Propagation conditions and correlation matrix (annex J)	Fraction of maximum throughput	FRC (annex A)	Additional DM-RS position	SNR (dB)
1	2	Normal	TDLA30-300 Low	70 %	G-FR2-A3-11	Pos0	-1.2
					G-FR2-A3-23	pos1	-1.3

**Table 8.2.2.5.2-2: Test requirements for PUSCH with 70% of maximum throughput, Type B, 50 MHz channel bandwidth, 120 kHz SCS in FR2-1**

Number of TX antennas	Number of demodulation branches	Cyclic prefix	Propagation conditions and correlation matrix (annex J)	Fraction of maximum throughput	FRC (annex A)	Additional DM-RS position	SNR (dB)
1	2	Normal	TDLA30-300 Low	70 %	G-FR2-A3-12	Pos0	-1.2
					G-FR2-A3-24	pos1	-1.3

**Table 8.2.2.5.2-3: Test requirements for PUSCH with 70% of maximum throughput, Type B, 100 MHz channel bandwidth, 120 kHz SCS in FR2-2**

Number of TX antennas	Number of demodulation branches	Cyclic prefix	Propagation conditions and correlation matrix (annex J)	Fraction of maximum throughput	FRC (annex A)	Additional DM-RS position	SNR (dB)
1	2	Normal	TDLA30-650 Low	70 %	G-FR2-A3B-6	pos1	0.7

**Table 8.2.2.5.2-4: Test requirements for PUSCH with 70% of maximum throughput, Type B, 400 MHz channel bandwidth, 480 kHz SCS in FR2-2**

Number of TX antennas	Number of demodulation branches	Cyclic prefix	Propagation conditions and correlation matrix (annex J)	Fraction of maximum throughput	FRC (annex A)	Additional DM-RS position	SNR (dB)
1	2	Normal	TDLA10-650 Low	70 %	G-FR2-A3B-7	pos1	0.8

## 8.2.3 Performance requirements for UCI multiplexed on PUSCH

### 8.2.3.1 Definition and applicability

The performance requirement of UCI multiplexed on PUSCH is determined by two parameters: block error probability (BLER) of CSI part 1 and block error probability of CSI part 2. The performance is measured by the required SNR at block error probability of CSI part 1 not exceeding 0.1 %, and the required SNR at block error probability of CSI part 2 not exceeding 1 %.

The CSI part 1 BLER is defined as the probability of incorrectly decoding the CSI part 1 information when the CSI part 1 information is sent.

The CSI part 2 BLER is defined as the probability of incorrectly decoding the CSI part 2 information when the CSI part 2 information is sent.

In the test of UCI multiplexed on PUSCH, the UCI information only contains CSI part 1 and CSI part 2 information, there is no HACK/ACK information transmitted.

The number of UCI information bit payload per slot is defined for two cases as follows:

- 7 bits: 5 bits in CSI part 1, 2 bits in CSI part 2
- 40 bits: 20 bits in CSI part 1, 20 bits in CSI part 2

The 7 bits UCI information case is further defined with the bitmap  $[c_0 c_1 c_2 c_3 c_4] = [0 1 0 1 0]$  for CSI part 1 information, where  $c_0$  is mapping to the RI information, and with the bitmap  $[c_0 c_1] = [1 0]$  for CSI part 2 information.

The 40 bits UCI information case is assumed random information bit selection.

In both tests, PUSCH data, CSI part 1 and CSI part 2 are transmitted simultaneously.

Which specific test(s) is applicable to BS is based on the test applicability rule defined in clause 8.1.2.

### 8.2.3.2 Minimum Requirement

For *BS type 1-O*, the minimum requirement is in TS 38.104 [2] clause 11.2.1.3.

For *BS type 2-O*, the minimum requirement is in TS 38.104 [2] clause 11.2.2.3.

### 8.2.3.3 Test purpose

The test shall verify the receiver's ability to detect UCI with CSI part 1 and CSI part 2 bits multiplexed on PUSCH under multipath fading propagation conditions for a given SNR.

### 8.2.3.4 Method of test

#### 8.2.3.4.1 Initial conditions

Test environment: Normal; see annex B.2.

RF channels to be tested for single carrier: M; see clause 4.9.1

Direction to be tested: OTA REFSSENS *receiver target reference direction* (see D.54 in table 4.6-1).

#### 8.2.3.4.2 Procedure

- 1) Place the BS with its manufacturer declared coordinate system reference point in the same place as calibrated point in the test system, as shown in annex E.3.
- 2) Align the manufacturer declared coordinate system orientation of the BS with the test system.
- 3) Set the BS in the declared direction to be tested.
- 4) Connect the BS tester generating the wanted signal, multipath fading simulators and AWGN generators to a test antenna via a combining network in OTA test setup, as shown in annex E.3. Each of the demodulation branch signals should be transmitted on one polarization of the test antenna(s).
- 5) The characteristics of the wanted signal shall be configured to the corresponding UL reference measurement channel defined in annex A, and according to additional test parameters listed in table 8.2.3.4.2-1. The UCI information bit payload per slot is equal to 7bits with CSI part 1 5bits, CSI part 2 2bits, and the UCI information bit payload per slot is equal to 40 bits with CSI part 1 20bits, CSI part 2 20 bits.

Table: 8.2.3.4.2-1 Test parameters for testing UCI multiplexed on PUSCH

Parameter		BS type 1-O	BS type 2-O
Transform precoding		Disabled	
Default TDD UL-DL pattern (Note 1)		30 kHz SCS: 7D1S2U, S=6D:4G:4U	120 kHz SCS: 3D1S1U, S=10D:2G:2U
HARQ	Maximum number of HARQ transmissions	1	
	RV sequence	0	
DM-RS	DM-RS configuration type	1	
	DM-RS duration	Single-symbol DM-RS	
	Additional DM-RS position	pos1	pos0,pos1
	Number of DM-RS CDM group(s) without data	2	
	Ratio of PUSCH EPRE to DM-RS EPRE	-3 dB	
	DM-RS port(s)	{0}	{0}
	DM-RS sequence generation	$N_{ID}^0=0, n_{SCID}=0$	
Time domain resource assignment	PUSCH mapping type	A,B	B
	Start symbol	0	
	Allocation length	14	10
Frequency domain resource assignment	RB assignment	Full applicable test bandwidth	
	Frequency hopping	Disabled	
Code block group based PUSCH transmission		Disabled	
PT-RS configuration	PT-RS	Disabled	Enabled
	Frequency density ( $K_{PT-RS}$ )	N.A.	2
	Time density ( $L_{PT-RS}$ )	N.A.	1
UCI	Number of CSI part1 and CSI part2 information bit payload	{5, 2}, {20,20}	
	scaling	1	
	betaOffsetACK-Index1	11	
	betaOffsetCSI-Part1-Index1 and betaOffsetCSI-Part1-Index2	13	
	betaOffsetCSI-Part2-Index1 and betaOffsetCSI-Part2-Index2	13	
	UCI partition for frequency hopping	Disabled	
NOTE 1: The same requirements are applicable to FDD and TDD with different UL-DL patterns for BS type 1-O, and the same requirements are applicable to TDD with different UL-DL patterns for BS type 2-O.			

- 6) The multipath fading emulators shall be configured according to the corresponding channel model defined in annex J.
- 7) Adjust the test signal mean power so the calibrated radiated SNR value at the BS receiver is as specified in clause 8.2.3.5.1 and 8.2.3.5.2 for BS type 1-O and BS type 2-O respectively, and that the SNR at the BS receiver is not impacted by the noise floor.

The power level for the transmission may be set such that the AWGN level at the RIB is equal to the AWGN level in table 8.2.3.4.2-2.

Table 8.2.3.4.2-2: AWGN power level at the BS input

BS type	Sub-carrier spacing (kHz)	Channel bandwidth (MHz)	AWGN power level
BS type 1-O (Note 4)	30	10	-83.6 - $\Delta_{OTAREFSENS}$ dBm / 8.64 MHz
BS type 2-O (Note 5)	120	50	$EIS_{REFSENS\_50M} + \Delta_{FR2\_REFSENS} + 15$ dBm / 46.08 MHz
NOTE 1: $\Delta_{OTAREFSENS}$ as declared in D.53 in table 4.6-1 and clause 7.1. NOTE 2: $\Delta_{FR2\_REFSENS} = -3$ dB as declared in clause 7.1, since the OTA REFSENS reference direction (as declared in D.54 in table 4.6-1) is used for testing. NOTE 3: $EIS_{REFSENS\_50M}$ as declared in D.28 in table 4.6-1. NOTE 4: The AWGN power level contains an AWGN offset of 16dB by default. If needed for test purposes, the AWGN level can be reduced from the default by any value in the range 0dB to 16dB. Changing the AWGN level does not impact the validity of the test, as it reduces the effective base band SNR level. NOTE 5: The AWGN power level contains an AWGN offset of 15dB by default. If needed for test purposes, the AWGN level can be reduced from the default by any value in the range 0dB to 15dB. Changing the AWGN level does not impact the validity of the test, as it reduces the effective base band SNR level.			

- 8) The signal generators sends a test pattern where UCI with CSI part 1 and CSI part 2 information can be multiplexed on PUSCH. The following statistics are kept: the number of incorrectly decoded CSI part 1 information transmitted, the number of incorrectly decoded CSI part 2 information transmitted during UCI multiplexed on PUSCH transmission.

### 8.2.3.5 Test Requirement

#### 8.2.3.5.1 Test requirement for BS type 1-0

The fraction of incorrectly decoded UCI with CSI part 1 according to clause 8.2.3.4.2 shall be less than 0.1 % for the SNR listed in table 8.2.3.5.1-1 and table 8.2.3.5.1-2. The fraction of incorrectly decoded UCI with CSI part 2 according to clause 8.2.3.4.2 shall be less than 1 % for the SNR listed in table 8.2.3.5.1-3 and table 8.2.3.5.1-4.

**Table 8.2.3.5.1-1: Test requirements for UCI multiplexed on PUSCH, Type A, CSI part 1, 10 MHz channel bandwidth, 30 kHz SCS**

Number of TX antennas	Number of demodulation branches	Cyclic Prefix	Propagation conditions and correlation matrix (Annex J)	UCI bits (CSI part 1, CSI part 2)	Additional DM-RS position	FRC (Annex A)	SNR (dB)
1	2	Normal	TDLC300-100 Low	7 (5, 2)	pos1	G-FR1-A4-11	6.0
	2	Normal	TDLC300-100 Low	40 (20,20)	pos1	G-FR1-A4-11	4.9

**Table 8.2.3.5.1-2: Test requirements for UCI multiplexed on PUSCH, Type B, CSI part 1, 10MHz channel bandwidth, 30 kHz SCS**

Number of TX antennas	Number of demodulation branches	Cyclic Prefix	Propagation conditions and correlation matrix (Annex J)	UCI bits (CSI part 1, CSI part 2)	Additional DM-RS position	FRC (Annex A)	SNR (dB)
1	2	Normal	TDLC300-100 Low	7 (5, 2)	pos1	G-FR1-A4-11	6.4
	2	Normal	TDLC300-100 Low	40 (20,20)	pos1	G-FR1-A4-11	4.7

**Table 8.2.3.5.1-3: Test requirements for UCI multiplexed on PUSCH, Type A, CSI part 2, 10MHz channel bandwidth, 30 kHz SCS**

Number of TX antennas	Number of demodulation branches	Cyclic Prefix	Propagation conditions and correlation matrix (Annex J)	UCI bits (CSI part 1, CSI part 2)	Additional DM-RS position	FRC (Annex A)	SNR (dB)
1	2	Normal	TDLC300-100 Low	7 (5, 2)	pos1	G-FR1-A4-11	0.4
	2	Normal	TDLC300-100 Low	40 (20,20)	pos1	G-FR1-A4-11	3.0

**Table 8.2.3.5.1-4: Test requirements for UCI multiplexed on PUSCH, Type B, CSI part 2, 10MHz channel bandwidth, 30 kHz SCS**

Number of TX antennas	Number of demodulation branches	Cyclic Prefix	Propagation conditions and correlation matrix (Annex J)	UCI bits (CSI part 1, CSI part 2)	Additional DM-RS position	FRC (Annex A)	SNR (dB)
1	2	Normal	TDLC300-100 Low	7 (5, 2)	pos1	G-FR1-A4-11	0.9
	2	Normal	TDLC300-100 Low	40 (20,20)	pos1	G-FR1-A4-11	3.2

**8.2.3.5.2 Test requirement for BS type 2-0**

The fraction of incorrectly decoded UCI with CSI part 1 measured according to clause 8.2.3.4.2 shall be less than 0.1 % for the SNR listed in table 8.2.3.5.2-1 and table 8.2.3.5.2-2. The fraction of incorrectly decoded UCI with CSI part 2 measured according to clause 8.2.3.4.2 shall be less than 1 % for the SNR listed in table 8.2.3.5.2-3 and table 8.2.3.5.2-4.

**Table 8.2.3.5.2-1: Test requirements for UCI multiplexed on PUSCH, Type B, with PT-RS, CSI part 1, 50 MHz channel bandwidth, 120 kHz SCS**

Number of TX antennas	Number of demodulation branches	Cyclic Prefix	Propagation conditions and correlation matrix (Annex J)	UCI bits (CSI part 1, CSI part 2)	Additional DM-RS position	FRC (Annex A)	SNR (dB)
1	2	Normal	TDLA30-300 Low	7 (5, 2)	pos0	G-FR2-A4-3	7.8
	2	Normal	TDLA30-300 Low	40 (20,20)	pos0	G-FR2-A4-3	6.4
	2	Normal	TDLA30-300 Low	7 (5, 2)	pos1	G-FR2-A4-13	8.4
	2	Normal	TDLA30-300 Low	40 (20,20)	pos1	G-FR2-A4-13	6.5

**Table 8.2.3.5.2-2: Test requirements for UCI multiplexed on PUSCH, Type B, without PT-RS, CSI part 1, 50MHz channel bandwidth, 120 kHz SCS**

Number of TX antennas	Number of demodulation branches	Cyclic Prefix	Propagation conditions and correlation matrix (Annex J)	UCI bits (CSI part 1, CSI part 2)	Additional DM-RS position	FRC (Annex A)	SNR (dB)
1	2	Normal	TDLA30-300 Low	7 (5, 2)	pos0	G-FR2-A4-3	7.7
	2	Normal	TDLA30-300 Low	40 (20,20)	pos0	G-FR2-A4-3	6.4
	2	Normal	TDLA30-300 Low	7 (5, 2)	pos1	G-FR2-A4-13	7.9
	2	Normal	TDLA30-300 Low	40 (20,20)	pos1	G-FR2-A4-13	6.1

**Table 8.2.3.5.2-3: Test requirements for UCI multiplexed on PUSCH, Type B, with PT-RS, CSI part 2, 50 MHz channel bandwidth, 120 kHz SCS**

Number of TX antennas	Number of demodulation branches	Cyclic Prefix	Propagation conditions and correlation matrix (Annex J)	UCI bits (CSI part 1, CSI part 2)	Additional DM-RS position	FRC (Annex A)	SNR (dB)
1	2	Normal	TDLA30-300 Low	7 (5, 2)	pos0	G-FR2-A4-3	1.7
	2	Normal	TDLA30-300 Low	40 (20,20)	pos0	G-FR2-A4-3	4.6
	2	Normal	TDLA30-300 Low	7 (5, 2)	pos1	G-FR2-A4-13	1.9
	2	Normal	TDLA30-300 Low	40 (20,20)	pos1	G-FR2-A4-13	4.6

**Table 8.2.3.5.2-4: Test requirements for UCI multiplexed on PUSCH, Type B, Without PT-RS, CSI part 2, 50MHz channel bandwidth, 120 kHz SCS**

Number of TX antennas	Number of demodulation branches	Cyclic Prefix	Propagation conditions and correlation matrix (Annex J)	UCI bits (CSI part 1, CSI part 2)	Additional DM-RS position	FRC (Annex A)	SNR (dB)
1	2	Normal	TDLA30-300 Low	7 (5, 2)	pos0	G-FR2-A4-3	1.7
	2	Normal	TDLA30-300 Low	40 (20,20)	pos0	G-FR2-A4-3	4.5
	2	Normal	TDLA30-300 Low	7 (5, 2)	pos1	G-FR2-A4-13	1.8
	2	Normal	TDLA30-300 Low	40 (20,20)	pos1	G-FR2-A4-13	4.3

## 8.2.4 Performance requirements for PUSCH for high speed train

### 8.2.4.1 Definition and applicability

The performance requirement of PUSCH is determined by a minimum required throughput for a given SNR. The required throughput is expressed as a fraction of maximum throughput for the FRCs listed in annex A. The performance requirements assume HARQ re-transmissions. The performance requirements for High Speed Train conditions are optional and only apply for FR2-1 below 30GHz.

Which specific test(s) are applicable to BS is based on the test applicability rules defined in clause 8.1.2.1 and clause 8.1.2.4.

The performance requirements for PUSCH for high speed train only apply to Wide Area Base Stations and Medium Range Base Stations (subject to declaration).

### 8.2.4.2 Minimum Requirement

For *BS type 1-O*, the minimum requirement is in TS 38.104 [2] clause 11.2.1.4.

For *BS type 2-O*, the minimum requirement is in TS 38.104 [2] clause 11.2.2.7.

### 8.2.4.3 Test Purpose

The test shall verify the receiver's ability to achieve throughput under high speed train and multipath fading propagation conditions for a given SNR.

### 8.2.4.4 Method of test

#### 8.2.4.4.1 Initial Conditions

Test environment: Normal, see annex B.2.

RF channels to be tested: M; see clause 4.9.1.

RF channels to be tested for carrier aggregation:  $M_{\text{BW Channel CA}}$ ; see clause 4.9.1.

Direction to be tested: OTA REFSENS *receiver target reference direction* (see D.54 in table 4.6-1).

#### 8.2.4.4.2 Procedure

- 1) Place the BS with its manufacturer declared coordinate system reference point in the same place as calibrated point in the test system, as shown in annex E.3.
- 2) Align the manufacturer declared coordinate system orientation of the BS with the test system.
- 3) Set the BS in the declared direction to be tested.
- 4) Connect the BS tester generating the wanted signal, multipath fading simulators and AWGN generators to a test antenna via a combining network in OTA test setup, as shown in annex E.3. Each of the demodulation branch signals should be transmitted on one polarization of the test antenna(s).
- 5) The characteristics of the wanted signal shall be configured according to the corresponding UL reference measurement channel defined in annex A, and according to additional test parameters listed in table 8.2.4.4.2-1 for *BS type 1-O* or table 8.2.4.4.2-1A for *BS type 2-O*.

**Table 8.2.4.4.2-1: Test parameters for testing PUSCH under HST conditions (*BS type 1-O*)**

Parameter		Value
Transform precoding		Disabled
Uplink-downlink allocation for TDD (Note1)		15 kHz SCS: 3D1S1U, S=10D:2G:2U 30 kHz SCS: 7D1S2U, S=6D:4G:4U
HARQ	Maximum number of HARQ transmissions	4
	RV sequence	0, 2, 3, 1
DM-RS	DM-RS configuration type	1
	DM-RS duration	single-symbol DM-RS
	First DM-RS position	pos 2 or pos 3 (NOTE 2)
	Additional DM-RS position	Pos2
	Number of DM-RS CDM group(s) without data	2
	Ratio of PUSCH EPRE to DM-RS EPRE	-3 dB
	DM-RS port	0
DM-RS sequence generation		$N_{ID}^0=0, n_{SCID}=0$
Time domain resource assignment	PUSCH mapping type	A
	Start symbol	0
	Allocation length	14
Frequency domain resource assignment	RB assignment	Full applicable test bandwidth
	Frequency hopping	Disabled
Code block group based PUSCH transmission		Disabled
NOTE 1: The same requirements are applicable to FDD and TDD with different UL-DL pattern.		
Note 2: Either pos2 or pos3 may be selected for conformance testing.		



**Table 8.2.4.4.2-1A: Test parameters for testing PUSCH under HST conditions (BS type 2-O)**

Parameter		Value
Transform precoding		Disabled
Default TDD UL-DL pattern (NOTE 1)		120 KHz SCS: 3D1S1U, S=10D:2G:2U
HARQ	Maximum number of HARQ transmissions	4
	RV sequence	0, 2, 3, 1
DM-RS	DM-RS configuration type	1
	DM-RS duration	single-symbol DM-RS
	Additional DM-RS symbols	pos0, pos1, pos2 (NOTE 2)
	Number of DM-RS CDM group(s) without data	2
	Ratio of PUSCH EPRE to DM-RS EPRE	-3 dB
	DM-RS port(s)	{0}
DM-RS sequence generation		NID=0, nSCID =0
Time domain resource	PUSCH mapping type	B
	Start symbol index	0
	Allocation length	10
Frequency domain resource	RB assignment	Full applicable test bandwidth
	Frequency hopping	Disabled
Code block group based PUSCH transmission		Disabled
PT-RS configuration	Frequency density (KPT-RS)	2
	Time density (LPT-RS)	1
NOTE 1: The same requirements are applicable to TDD with different UL-DL patterns		
NOTE 2: Either pos0, pos1 or pos2 may be selected for conformance testing.		

The channel emulators shall be configured according to the corresponding channel model defined in annex J. Unless stated otherwise, the MIMO correlation matrices for the gNB are defined in annex J for low correlation.

- 7) Adjust the test signal mean power so the calibrated radiated SNR value at the BS receiver is as specified in clause 8.2.4.5 (BS type 1-O) or clause 8.2.4.6 (BS type 2-O) and that the SNR at the BS receiver is not impacted by the noise floor.

The power level for the transmission may be set such that the AWGN level at the RIB is equal to the AWGN level in table 8.2.4.4.2-2.

**Table 8.2.4.4.2-2: AWGN power level at the BS input**

BS type	Sub-carrier spacing (kHz)	Channel bandwidth (MHz)	AWGN power level
1-O (NOTE 2)	15	5	-86.5 - $\Delta_{OTAREFSENS}$ dBm / 4.5MHz
		10	-83.3 - $\Delta_{OTAREFSENS}$ dBm / 9.36 MHz
	30	10	-83.6 - $\Delta_{OTAREFSENS}$ dBm / 8.64MHz
		40	-77.2 - $\Delta_{OTAREFSENS}$ dBm / 38.16 MHz
2-O (NOTE 3)	120	50	$E_{ISREFSENS\_50M} + \Delta_{FR2\_REFSENS} + 15$ dBm / 46.08 MHz
		200	$E_{ISREFSENS\_50M} + \Delta_{FR2\_REFSENS} + 21$ dBm / 190.08 MHz
NOTE 1: $\Delta_{OTAREFSENS}$ as declared in D.53 in table 4.6-1 and clause 7.1.			
NOTE 2: The AWGN power level contains an AWGN offset of 16dB by default. If needed for test purposes, the AWGN level can be reduced from the default by any value in the range 0dB to 16dB. Changing the AWGN level does not impact the validity of the test, as it reduces the effective base band SNR level			
NOTE 3: The AWGN power level contains an AWGN offset of 15dB by default. If needed for test purposes, the AWGN level can be reduced from the default by any value in the range 0dB to 15dB. Changing the AWGN level does not impact the validity of the test, as it reduces the effective base band SNR level.			

- 8) For reference channels applicable to the BS, measure the throughput.

### 8.2.4.5 Test Requirement for *BS Type 1-0*

The throughput measured according to clause 8.2.4.4.2 shall not be below the limits for the SNR levels specified in table 8.2.4.5-1 to 8.2.4.5-10. Unless stated otherwise, the MIMO correlation matrices for the gNB are defined in annex J for low correlation.

**Table 8.2.4.5-1: Test requirements for PUSCH, Type A, 10 MHz channel bandwidth, 15 kHz SCS, 350 km/h**

Number of TX antennas	Number of demodulation branches	Cyclic prefix	Propagation conditions (Annex J)	Fraction of maximum throughput	FRC (Annex A)	Additional DM-RS position	SNR (dB)
1	2	Normal	HST Scenario 1-NR350	70 %	G-FR1-A3-33	pos2	-3.4
		Normal	HST Scenario 1-NR350	70 %	G-FR1-A4-29	pos2	8.7
		Normal	HST Scenario 3-NR350	70 %	G-FR1-A3-33	pos2	-3.3
		Normal	HST Scenario 3-NR350	70 %	G-FR1-A4-29	pos2	9.0

**Table 8.2.4.5-2: Test requirements for PUSCH, Type A, 40 MHz channel bandwidth, 30 kHz SCS, 350 km/h**

Number of TX antennas	Number of demodulation branches	Cyclic prefix	Propagation conditions (Annex J)	Fraction of maximum throughput	FRC (Annex A)	Additional DM-RS position	SNR (dB)
1	2	Normal	HST Scenario 1-NR350	70 %	G-FR1-A3-34	pos2	-3.4
		Normal	HST Scenario 1-NR350	70 %	G-FR1-A4-30	pos2	8.8
		Normal	HST Scenario 3-NR350	70 %	G-FR1-A3-34	pos2	-3.2
		Normal	HST Scenario 3-NR350	70 %	G-FR1-A4-30	pos2	9.1

**Table 8.2.4.5-3: Test requirements for PUSCH, Type A, 10 MHz channel bandwidth, 15 kHz SCS, 500 km/h**

Number of TX antennas	Number of demodulation branches	Cyclic prefix	Propagation conditions (Annex J)	Fraction of maximum throughput	FRC (Annex A)	Additional DM-RS position	SNR (dB)
1	2	Normal	HST Scenario 1-NR500	70 %	G-FR1-A3-33	pos2	-3.6
		Normal	HST Scenario 1-NR500	70 %	G-FR1-A4-29	pos2	8.8
		Normal	HST Scenario 3-NR500	70 %	G-FR1-A3-33	pos2	-3.3
		Normal	HST Scenario 3-NR500	70 %	G-FR1-A4-29	pos2	9.5

**Table 8.2.4.5-4: Test requirements for PUSCH, Type A, 40 MHz channel bandwidth, 30 kHz SCS, 500 km/h**

Number of TX antennas	Number of demodulation branches	Cyclic prefix	Propagation conditions (Annex J)	Fraction of maximum throughput	FRC (Annex A)	Additional DM-RS position	SNR (dB)
1	2	Normal	HST Scenario 1-NR500	70 %	G-FR1-A3-34	pos2	-3.6
		Normal	HST Scenario 1-NR500	70 %	G-FR1-A4-30	pos2	9.0
		Normal	HST Scenario 3-NR500	70 %	G-FR1-A3-34	pos2	-3.1
		Normal	HST Scenario 3-NR500	70 %	G-FR1-A4-30	pos2	10.5

**Table 8.2.4.5-5: Test requirements for PUSCH, Type A, 5 MHz channel bandwidth, 15 kHz SCS, 350 km/h**

Number of TX antennas	Number of demodulation branches	Cyclic prefix	Propagation conditions (Annex J)	Fraction of maximum throughput	FRC (Annex A)	Additional DM-RS position	SNR (dB)
1	2	Normal	HST Scenario 1-NR350	70 %	G-FR1-A3-33A	pos2	-3.4
		Normal	HST Scenario 1-NR350	70 %	G-FR1-A4-29A	pos2	8.8
		Normal	HST Scenario 3-NR350	70 %	G-FR1-A3-33A	pos2	-3.3
		Normal	HST Scenario 3-NR350	70 %	G-FR1-A4-29A	pos2	8.9

**Table 8.2.4.5-6: Test requirements for PUSCH, Type A, 10 MHz channel bandwidth, 30 kHz SCS, 350 km/h**

Number of TX antennas	Number of demodulation branches	Cyclic prefix	Propagation conditions (Annex J)	Fraction of maximum throughput	FRC (Annex A)	Additional DM-RS position	SNR (dB)
1	2	Normal	HST Scenario 1-NR350	70 %	G-FR1-A3-34A	pos2	-3.3
		Normal	HST Scenario 1-NR350	70 %	G-FR1-A4-30A	pos2	8.6
		Normal	HST Scenario 3-NR350	70 %	G-FR1-A3-34A	pos2	-3.3
		Normal	HST Scenario 3-NR350	70 %	G-FR1-A4-30A	pos2	8.9

**Table 8.2.4.5-7: Test requirements for PUSCH, Type A, 5 MHz channel bandwidth, 15 kHz SCS, 500 km/h**

Number of TX antennas	Number of demodulation branches	Cyclic prefix	Propagation conditions (Annex J)	Fraction of maximum throughput	FRC (Annex A)	Additional DM-RS position	SNR (dB)
1	2	Normal	HST Scenario 1-NR500	70 %	G-FR1-A3-33A	pos2	-3.3
		Normal	HST Scenario 1-NR500	70 %	G-FR1-A4-29A	pos2	9.0
		Normal	HST Scenario 3-NR500	70 %	G-FR1-A3-33A	pos2	-3.2
		Normal	HST Scenario 3-NR500	70 %	G-FR1-A4-29A	pos2	9.1

**Table 8.2.4.5-8: Test requirements for PUSCH, Type A, 10 MHz channel bandwidth, 30 kHz SCS, 500 km/h**

Number of TX antennas	Number of demodulation branches	Cyclic prefix	Propagation conditions (Annex J)	Fraction of maximum throughput	FRC (Annex A)	Additional DM-RS position	SNR (dB)
1	2	Normal	HST Scenario 1-NR500	70 %	G-FR1-A3-34A	pos2	-3.3
		Normal	HST Scenario 1-NR500	70 %	G-FR1-A4-30A	pos2	8.9
		Normal	HST Scenario 3-NR500	70 %	G-FR1-A3-34A	pos2	-3.1
		Normal	HST Scenario 3-NR500	70 %	G-FR1-A4-30A	pos2	8.9

**Table 8.2.4.5-9: Test requirements for PUSCH, Type A, 5 MHz channel bandwidth, 15 kHz SCS, multi-path fading channel**

Number of TX antennas	Number of demodulation branches	Cyclic prefix	Propagation conditions (Annex J)	Frequency offset (Hz)	Fraction of maximum throughput	FRC (Annex A)	Additional DM-RS position	SNR (dB)
1	2	Normal	TDLC300-600	0	70 %	G-FR1-A3-33A	pos2	-1.3

**Table 8.2.4.5-10: Test requirements for PUSCH, Type A, 10 MHz channel bandwidth, 30 kHz SCS, multi-path fading channel**

Number of TX antennas	Number of demodulation branches	Cyclic prefix	Propagation conditions (Annex J)	Frequency offset (Hz)	Fraction of maximum throughput	FRC (Annex A)	Additional DM-RS position	SNR (dB)
1	2	Normal	TDLC300-1200	0	70 %	G-FR1-A3-34A	pos2	-1.4

### 8.2.4.6 Test Requirement for *BS Type 2-O*

The throughput measured according to clause 8.2.4.4.2 shall not be below the limits for the SNR levels specified in table 8.2.4.6-1 to 8.2.4.6-2. Unless stated otherwise, the MIMO correlation matrices for the gNB are defined in annex J for low correlation.

**Table 8.2.4.6-1: Test requirements for PUSCH, Type B, 50 MHz channel bandwidth, 120 kHz SCS, 350 km/h**

Number of TX antennas	Number of demodulation branches	Cyclic prefix	Propagation conditions (Annex J)	Fraction of maximum throughput	FRC (Annex A)	Additional DM-RS position	SNR (dB)
1	2	Normal	Scenario 4-BI-NR350, FR2	70 %	G-FR2-A10-1	pos0	13.5
		Normal	Scenario 4-BI-NR350, FR2	70 %	G-FR2-A10-3, G-FR2-A10-5	pos1, pos2	13.1

**Table 8.2.4.6-2: Test requirements for PUSCH, Type B, 200 MHz channel bandwidth, 120 kHz SCS, 350 km/h**

Number of TX antennas	Number of demodulation branches	Cyclic prefix	Propagation conditions (Annex J)	Fraction of maximum throughput	FRC (Annex A)	Additional DM-RS position	SNR (dB)
1	2	Normal	Scenario 4-BI-NR350, FR2	70 %	G-FR2-A10-2	pos0	13.4
		Normal	Scenario 4-BI-NR350, FR2	70 %	G-FR2-A10-4, G-FR2-A10-6	pos1, pos2	12.9

## 8.2.5 Performance requirements for UL timing adjustment

### 8.2.5.1 Definition and applicability

The performance requirement of UL timing adjustment is determined by a minimum required throughput for the moving UE at given SNR. The performance requirements assume HARQ retransmissions. The performance requirements for UL timing adjustment scenario Y and scenario Z defined in Annex J.4 are optional. The performance requirements for UL timing adjustment scenario Y in FR2 apply only to FR2-1 below 30GHz.

In the tests for UL timing adjustment, two signals are configured, one being transmitted by a moving UE and the other being transmitted by a stationary UE. The transmission of SRS from UE is optional. FRC parameters in Tables A.4-2B, A.10-4, A.10-5, and A.10-6 are applied for both UEs. The received power for both UEs is the same. The resource blocks allocated for both UEs are consecutive. In scenario Y and scenario Z, Doppler shift is not taken into account.

Which specific test(s) are applicable to BS is based on the test applicability rules defined in clause 8.1.2.1.

### 8.2.5.2 Minimum Requirement

The minimum requirement is in TS 38.104 [2] clause 12.2.1.5 and 12.2.2. 8.

### 8.2.5.3 Test Purpose

The test shall verify the receiver's ability to achieve throughput measured for the moving UE at given SNR under moving propagation conditions.

### 8.2.5.4 Method of test

#### 8.2.5.4.1 Initial Conditions

Test environment: Normal, see annex B.2.

RF channels to be tested: M; see clause 4.9.1.

RF channels to be tested for carrier aggregation:  $M_{\text{BW Channel CA}}$ ; see clause 4.9.1.

Direction to be tested: OTA REFSENS *receiver target reference direction* (see D.54 in table 4.6-1).

#### 8.2.5.4.2 Procedure

- 1) Place the BS with its manufacturer declared coordinate system reference point in the same place as calibrated point in the test system, as shown in annex E.3.
- 2) Align the manufacturer declared coordinate system orientation of the BS with the test system.
- 3) Set the BS in the declared direction to be tested.
- 4) Connect the BS tester generating the wanted signal, multipath fading simulators and AWGN generators to a test antenna via a combining network in OTA test setup, as shown in annex E.3. Each of the demodulation branch signals should be transmitted on one polarization of the test antenna(s).
- 5) The characteristics of the wanted signal shall be configured according to the corresponding UL reference measurement channel defined in annex A, and according to additional test parameters listed in table 8.2.5.4.2-1 and table 8.2.5.4.2-1a.

Table 8.2.5.4.2-1 Test parameters for testing UL timing adjustment for *BS type 1-O*

Parameter		Value
Transform precoding		Disabled
Uplink-downlink allocation for TDD		15 kHz SCS: 3D1S1U, S=10D:2G:2U 30 kHz SCS: 7D1S2U, S=6D:4G:4U
HARQ	Maximum number of HARQ transmissions	4
	RV sequence	0, 2, 3, 1
DM-RS	DM-RS configuration type	1
	DM-RS duration	single-symbol DM-RS
	Additional DM-RS position	pos2
	Number of DM-RS CDM group(s) without data	2
	Ratio of PUSCH EPRE to DM-RS EPRE	-3 dB
	DM-RS port	{0}
	DM-RS sequence generation	$N_{ID}^0=0, n_{SCID}=0$ for moving UE $N_{ID}^0=1, n_{SCID}=1$ for stationary UE
Time domain resource assignment	PUSCH mapping type	A,B
	Allocation length	14
Frequency domain resource assignment	RB assignment	5 MHz CBW/15 KHz: 12 RB for each UE 10MHz CBW/15 KHz SCS: 25 RB for each UE 10MHz CBW/30 KHz: 12 RB for each UE 40MHz CBW/30 KHz SCS: 50 RB for each UE
		Starting PRB index
	Frequency hopping	Disabled
SRS resource allocation	Slots in which sounding RS is transmitted (Note 1)	For FDD: slot #1 in radio frames For TDD: - last symbol in slot #3 in radio frames for 15 KHz - last symbol in slot #7 in radio frames for 30 KHz
	SRS resource allocation	15 kHz SCS: - $C_{SRS}=5, B_{SRS}=0$ , for 20 RB - $C_{SRS}=11, B_{SRS}=0$ , for 40 RB 30 kHz SCS: - $C_{SRS}=5, B_{SRS}=0$ , for 20 RB - $C_{SRS}=21, B_{SRS}=0$ , for 80 RB
NOTE 1. The transmission of SRS is optional. And the transmission comb and SRS periodicity are configured as $K_{TC}=2$ , and $T_{SRS}=10$ for 15 KHz SCS, $T_{SRS}=20$ for 30 KHz SCS respectively.		

Table 8.2.5.4.2-1a Test parameters for testing UL timing adjustment for *BS type 2-O*

Parameter		Value
Transform precoding		Disabled
Uplink-downlink allocation for TDD		120 kHz SCS: 3D1S1U, S=10D:2G:2U
Channel bandwidth		120 kHz SCS: 50MHz, 200 MHz
HARQ	Maximum number of HARQ transmissions	4
	RV sequence	0, 2, 3, 1
DM-RS	DM-RS configuration type	1
	DM-RS duration	single-symbol DM-RS
	DM-RS position ( $l_0$ )	2
	Additional DM-RS position	pos0, pos1, pos2
	Number of DM-RS CDM group(s) without data	2
	Ratio of PUSCH EPRE to DM-RS EPRE	-3 dB
	DM-RS port	{0}
Time domain resource assignment	DM-RS sequence generation	$N_{ID}^0=0, n_{SCID}=0$ for moving UE $N_{ID}^0=1, n_{SCID}=1$ for stationary UE
	PUSCH mapping type	B
	Allocation length	10
Frequency domain resource assignment	RB assignment	50 MHz CBW/120 KHz SCS: 16 RB for each UE 200MHz CBW/120 KHz SCS: 66 RB for each UE
	Starting PRB index	Moving UE: 0 Stationary UE: 16 for 50MHz CBW, 66 for 200MHz CBW for SCS 120 KHz
	Frequency hopping	Disabled
SRS resource allocation	Slots in which sounding RS is transmitted (Note 1)	For TDD: - last symbol in slot #3 in radio frames for 120 KHz
	SRS resource allocation	120 kHz SCS: - $C_{SRS} = 9, B_{SRS} = 0$ , for 32 RB - $C_{SRS} = 33, B_{SRS} = 0$ , for 132 RB
NOTE 1. The transmission of SRS is optional. And the transmission comb and SRS periodic are configured as $K_{TC} = 2$ , and $T_{SRS} = 80$ respectively.		

The multipath fading emulators shall be configured according to the corresponding channel model defined in annex J. Unless stated otherwise, the MIMO correlation matrices for the gNB are defined in annex J for low correlation.

- 7) Adjust the test signal mean power so the calibrated radiated SNR value at the BS receiver is as specified in clause 8.2.5.5 for high speed train and clause 8.2.5.6 for normal mode and that the SNR at the BS receiver is not impacted by the noise floor.

The power level for the transmission may be set such that the AWGN level at the RIB is equal to the AWGN level in table 8.2.5.4.2-2.

Table 8.2.5.4.2-2: AWGN power level at the BS input

BS type	Sub-carrier spacing (kHz)	Channel bandwidth (MHz)	AWGN power level
1-O (NOTE 2)	15	5	-86.5dBm - $\Delta_{OTAREFSENS}$ dBm / 4.5MHz
		10	-83.3 - $\Delta_{OTAREFSENS}$ dBm / 9.36 MHz
	30	10	-83.6 dBm - $\Delta_{OTAREFSENS}$ dBm / 8.64MHz
		40	-77.2 - $\Delta_{OTAREFSENS}$ dBm / 38.16 MHz
2-O (NOTE 3)	120	50	EIS <sub>REFSENS_50M</sub> + $\Delta_{FR2\_REFSENS}$ + 15 dBm / 46.08 MHz
		200	EIS <sub>REFSENS_50M</sub> + $\Delta_{FR2\_REFSENS}$ + 21 dBm / 190.08 MHz
NOTE 1: $\Delta_{OTAREFSENS}$ as declared in D.53 in table 4.6-1 and clause 7.1.			
NOTE 2: The AWGN power level contains an AWGN offset of 16dB by default. If needed for test purposes, the AWGN level can be reduced from the default by any value in the range 0dB to 16dB. Changing the AWGN level does not impact the validity of the test, as it reduces the effective base band SNR level.			
NOTE 3: The AWGN power level contains an AWGN offset of 15dB by default. If needed for test purposes, the AWGN level can be reduced from the default by any value in the range 0dB to 15dB. Changing the AWGN level does not impact the validity of the test, as it reduces the effective base band SNR level.			

8) For reference channels applicable to the BS, measure the throughput.

### 8.2.5.5 Test Requirement for High Speed Train for BS type 1-O

The throughput shall be  $\geq 70\%$  of the maximum throughput of the reference measurement channel as specified in annex A measured for the moving UE according to clause 8.2.5.4.2 shall not be below the limits for the SNR levels specified in table 8.2.5.5-1 for mapping type A and table 8.2.5.5-2 for mapping type B respectively.

Table 8.2.5.5-1 Test requirements for UL timing adjustment with mapping type A for high speed train

Number of TX antennas	Number of demodulation branches	Cyclic prefix	Channel Bandwidth [MHz]	SCS [kHz]	Moving propagation conditions and correlation matrix (Annex J)	FRC (Annex A)	SNR [dB]
1	2	Normal	5	15	Scenario Y	G-FR1-A4-31A	8.5
					Scenario Z	G-FR1-A4-31A	8.6
			10	15	Scenario Y	G-FR1-A4-31	8.8
					Scenario Z	G-FR1-A4-31	8.7
			10	30	Scenario Y	G-FR1-A4-32A	8.6
					Scenario Z	G-FR1-A4-32A	8.6
			40	30	Scenario Y	G-FR1-A4-32	8.7
					Scenario Z	G-FR1-A4-32	8.8

Table 8.2.5.5-2 Test requirements for UL timing adjustment with mapping type B for high speed train

Number of TX antennas	Number of demodulation branches	Cyclic prefix	Channel Bandwidth [MHz]	SCS [kHz]	Moving propagation conditions and correlation matrix (Annex J)	FRC (Annex A)	SNR [dB]
1	2	Normal	5	15	Scenario Y	G-FR1-A4-31A	8.6
					Scenario Z	G-FR1-A4-31A	8.6
			10	15	Scenario Y	G-FR1-A4-31	8.8
					Scenario Z	G-FR1-A4-31	8.8
			10	30	Scenario Y	G-FR1-A4-32A	8.6
					Scenario Z	G-FR1-A4-32A	8.7
			40	30	Scenario Y	G-FR1-A4-32	8.7
					Scenario Z	G-FR1-A4-32	8.8



### 8.2.5.5a Test Requirement for High Speed Train *for BS type 2-0*

The throughput shall be  $\geq 70\%$  of the maximum throughput of the reference measurement channel as specified in annex A measured for the moving UE according to clause 8.2.5.4.2 shall not be below the limits for the SNR levels specified in table 8.2.5.5a-1 for mapping type B.

**Table 8.2.5.5a-1 Minimum requirements for UL timing adjustment with mapping type B for high speed train**

Number of TX antennas	Number of demodulation branches	Cyclic prefix	Channel Bandwidth [MHz]	SCS [kHz]	Moving propagation conditions and correlation matrix (Annex J)	FRC (Annex A)	SNR [dB]
1	2	Normal	50	120	Scenario Y	G-FR2-A10-7	9.7
					Scenario Y	G-FR2-A10-9, G-FR2-A10-11	9.4
			200	120	Scenario Y	G-FR2-A10-8	9.6
					Scenario Y	G-FR2-A10-10, G-FR2-A20-12	9.5

### 8.2.5.6 Test Requirement for Normal Mode

The throughput shall be  $\geq 70\%$  of the maximum throughput of the reference measurement channel as specified in annex A measured for the moving UE according to clause 8.2.5.4.2 shall not be below the limits for the SNR levels specified in table 8.2.5.6-1 for mapping type A and table 8.2.5.6-2 for mapping type B respectively.

**Table 8.2.5.6-1 Test requirements for UL timing adjustment with mapping type A for normal mode**

Number of TX antennas	Number of demodulation branches	Cyclic prefix	Channel Bandwidth [MHz]	SCS [kHz]	Moving propagation conditions and correlation matrix (Annex J)	FRC (Annex A)	SNR [dB]
1	2	Normal	5	15	Scenario X	G-FR1-A4-31A	11.2
			10	15	Scenario X	G-FR1-A4-31	11.8
			10	30	Scenario X	G-FR1-A4-32A	11.4
			40	30	Scenario X	G-FR1-A4-32	12.6

**Table 8.2.5.6-2 Test requirements for UL timing adjustment with mapping type B for normal mode**

Number of TX antennas	Number of demodulation branches	Cyclic prefix	Channel Bandwidth [MHz]	SCS [kHz]	Moving propagation conditions and correlation matrix (Annex J)	FRC (Annex A)	SNR [dB]
1	2	Normal	5	15	Scenario X	G-FR1-A4-31A	11.2
			10	15	Scenario X	G-FR1-A4-31	11.9
			10	30	Scenario X	G-FR1-A4-32A	11.3
			40	30	Scenario X	G-FR1-A4-32	13.0

## 8.2.6 Performance requirements for PUSCH with 0.001% BLER

### 8.2.6.1 Definition and applicability

The performance requirement of PUSCH is determined by a maximum required transport block error rate (BLER) for a given SNR. The required BLER is defined as the probability of incorrectly decoding the transport block after reaching the maximum number of HARQ transmissions for the FRCs listed in annex A.

### 8.2.6.2 Minimum Requirement

For *BS type 1-O*, the minimum requirement is in TS 38.104 [2], clause 11.2.1.6.

For *BS type 2-O*, no requirement and no test are defined.

### 8.2.6.3 Test Purpose

The test shall verify the receiver's ability to achieve 0.001% BLER under AWGN conditions for a given SNR.

### 8.2.6.4 Method of test

#### 8.2.6.4.1 Initial Conditions

Test environment: Normal, see annex B.2.

RF channels to be tested:  $M$ ; see clause 4.9.1.

RF channels to be tested for carrier aggregation:  $M_{\text{BW Channel CA}}$ ; see clause 4.9.1.

Direction to be tested: OTA REFSENS *receiver target reference direction* (see D.54 in table 4.6-1).

#### 8.2.6.4.2 Procedure

- 1) Place the BS with its manufacturer declared coordinate system reference point in the same place as calibrated point in the test system, as shown in annex E.3.
- 2) Align the manufacturer declared coordinate system orientation of the BS with the test system.
- 3) Set the BS in the declared direction to be tested.
- 4) Connect the BS tester generating the wanted signal, multipath fading simulators and AWGN generators to a test antenna via a combining network in OTA test setup, as shown in annex E.3. Each of the demodulation branch signals should be transmitted on one polarization of the test antenna(s).
- 5) The characteristics of the wanted signal shall be configured according to the corresponding UL reference measurement channel defined in annex A, and according to additional test parameters listed in table 8.2.5.4.2-1.

**Table 8.2.6.4.2-1: Test parameters for testing PUSCH with 0.001% BLER**

Parameter		Value
Transform precoding		Disabled
Default TDD UL-DL pattern (Note 1)		15 kHz SCS: 3D1S1U, S=10D:2G:2U 30 kHz SCS: 7D1S2U, S=6D:4G:4U
HARQ	Maximum number of HARQ transmissions	1
	RV sequence	0
DM-RS	DM-RS configuration type	1
	DM-RS duration	single-symbol DM-RS
	Additional DM-RS position	Pos1
	Number of DM-RS CDM group(s) without data	1
	Ratio of PUSCH EPRE to DM-RS EPRE	-3 dB
	DM-RS port(s)	{0}
	DM-RS sequence generation	$N_{ID}^0=0, n_{SCID}=0$
Time domain resource assignment	PUSCH mapping type	A, B
	Start symbol	0
	Allocation length	14
Frequency domain resource assignment	RB assignment	Full applicable test bandwidth
	Frequency hopping	Disabled
Code block group based PUSCH transmission		Disabled
Note 1: The same requirements are applicable to FDD and TDD with different UL-DL patterns.		

No multipath fading channel is included in the test.

- 7) Adjust the test signal mean power so the calibrated radiated SNR value at the BS receiver is as specified in clause 8.2.6.5 and that the SNR at the BS receiver is not impacted by the noise floor.

The power level for the transmission may be set such that the AWGN level at the RIB is equal to the AWGN level in table 8.2.6.4.2-2.

**Table 8.2.6.4.2-2: AWGN power level at the BS input**

BS type	Sub-carrier spacing (kHz)	Channel bandwidth (MHz)	AWGN power level
1-O (NOTE 2)	15	10	$-83.3 - \Delta_{OTAREFSENS}$ dBm / 9.36 MHz
	30	40	$-77.2 - \Delta_{OTAREFSENS}$ dBm / 38.16 MHz
NOTE 1: $\Delta_{OTAREFSENS}$ as declared in D.53 in table 4.6-1 and clause 7.1.			
NOTE 2: The AWGN power level contains an AWGN offset of 16dB by default. If needed for test purposes, the AWGN level can be reduced from the default by any value in the range 0dB to 16dB. Changing the AWGN level does not impact the validity of the test, as it reduces the effective base band SNR level.			

- 8) For reference channels applicable to the BS, measure the BLER. BLER is evaluated based on the test methodology described in Annex I.

## 8.2.6.5 Test requirement

### 8.2.6.5.1 Test requirement for BS type 1-O

The throughput measured according to clause 8.2.6.4.2 shall not be below the limits for the SNR levels specified in table 8.2.6.5.1-1 to table 8.2.6.5.1-8 for 0.001% BLER if declared to be supported.

**Table 8.2.6.5.1-1: Test requirements for PUSCH with 0.001% BLER, Type A, 5 MHz channel bandwidth, 15 kHz SCS**

Number of TX antennas	Number of demodulation branches	Cyclic prefix	Propagation conditions	BLER	FRC (annex A)	Additional DM-RS position	SNR (dB)
1	2	Normal	AWGN	0.001%	G-FR1-A3A-1	Pos1	-3.8

**Table 8.2.6.5.1-2: Test requirements for PUSCH with 0.001% BLER, Type A, 10 MHz channel bandwidth, 15 kHz SCS**

Number of TX antennas	Number of demodulation branches	Cyclic prefix	Propagation conditions	BLER	FRC (annex A)	Additional DM-RS position	SNR (dB)
1	2	Normal	AWGN	0.001%	G-FR1-A3A-2	Pos1	-4.6

**Table 8.2.6.5.1-3: Test requirements for PUSCH with 0.001% BLER, Type A, 10 MHz channel bandwidth, 30 kHz SCS**

Number of TX antennas	Number of demodulation branches	Cyclic prefix	Propagation conditions	BLER	FRC (annex A)	Additional DM-RS position	SNR (dB)
1	2	Normal	AWGN	0.001%	G-FR1-A3A-3	Pos1	-4.1

**Table 8.2.6.5.1-4: Test requirements for PUSCH with 0.001% BLER, Type A, 40 MHz channel bandwidth, 30 kHz SCS**

Number of TX antennas	Number of demodulation branches	Cyclic prefix	Propagation conditions	BLER	FRC (annex A)	Additional DM-RS position	SNR (dB)
1	2	Normal	AWGN	0.001%	G-FR1-A3A-4	Pos1	-4.9

**Table 8.2.6.5.1-5: Test requirements for PUSCH with 0.001% BLER, Type B, 5 MHz channel bandwidth, 15 kHz SCS**

Number of TX antennas	Number of demodulation branches	Cyclic prefix	Propagation conditions	BLER	FRC (annex A)	Additional DM-RS position	SNR (dB)
1	2	Normal	AWGN	0.001%	G-FR1-A3A-1	Pos1	-3.9

**Table 8.2.6.5.1-6: Test requirements for PUSCH with 0.001% BLER, Type B, 10 MHz channel bandwidth, 15 kHz SCS**

Number of TX antennas	Number of demodulation branches	Cyclic prefix	Propagation conditions	BLER	FRC (annex A)	Additional DM-RS position	SNR (dB)
1	2	Normal	AWGN	0.001%	G-FR1-A3A-2	Pos1	-4.6

**Table 8.2.6.5.1-7: Test requirements for PUSCH with 0.001% BLER, Type B, 10 MHz channel bandwidth, 30 kHz SCS**

Number of TX antennas	Number of demodulation branches	Cyclic prefix	Propagation conditions	BLER	FRC (annex A)	Additional DM-RS position	SNR (dB)
1	2	Normal	AWGN	0.001%	G-FR1-A3A-3	Pos1	-4.1

**Table 8.2.6.5.1-8: Test requirements for PUSCH with 0.001% BLER, Type B, 40 MHz channel bandwidth, 30 kHz SCS**

Number of TX antennas	Number of demodulation branches	Cyclic prefix	Propagation conditions	BLER	FRC (annex A)	Additional DM-RS position	SNR (dB)
1	2	Normal	AWGN	0.001%	G-FR1-A3A-4	Pos1	-4.9

NOTE: If the above Test Requirement differs from the Minimum Requirement then the Test Tolerance applied for this test is non-zero. The Test Tolerance for this test and the explanation of how the Minimum Requirement has been relaxed by the Test Tolerance is given in annex C.

## 8.2.7 Performance requirements for PUSCH repetition Type A

### 8.2.7.1 Definition and applicability

The performance requirement of PUSCH repetition Type A is determined by block error probability (BLER). The performance is measured by the required SNR at block error probability of PUSCH data not exceeding 1 %. The performance requirements assume HARQ re-transmissions.

Which specific test(s) are applicable to BS is based on the test applicability rules defined in clause 8.1.2.1.

### 8.2.7.2 Minimum Requirement

For *BS type 1-O*, the minimum requirement is in TS 38.104 [2], clause 11.2.1.7.

For *BS type 2-O*, the minimum requirement is in TS 38.104 [2], clause 11.2.2.7.

### 8.2.7.3 Test purpose

The test shall verify the receiver's ability to achieve target block error probability of PUSCH repetition Type A under multipath fading propagation conditions for a given SNR.

### 8.2.7.4 Method of test

#### 8.2.7.4.1 Initial conditions

Test environment: Normal, see annex B.2.

RF channels to be tested for single carrier: M, see clause 4.9.1.

RF channels to be tested for carrier aggregation:  $M_{\text{BW Channel CA}}$ ; see clause 4.9.1.

Direction to be tested: OTA REFSENS *receiver target reference direction* (see D.54 in table 4.6-1).

#### 8.2.7.4.2 Procedure

- 1) Place the BS with its manufacturer declared coordinate system reference point in the same place as calibrated point in the test system, as shown in annex E.3.
- 2) Align the manufacturer declared coordinate system orientation of the BS with the test system.
- 3) Set the BS in the declared direction to be tested.
- 4) Connect the BS tester generating the wanted signal, multipath fading simulators and AWGN generators to a test antenna via a combining network in OTA test setup, as shown in annex E.3. Each of the demodulation branch signals should be transmitted on one polarization of the test antenna(s).
- 5) The characteristics of the wanted signal shall be configured according to the corresponding UL reference measurement channel defined in annex A, and according to additional test parameters listed in table 8.2.7.4.2-1.

Table 8.2.7.4.2-1: Test parameters for testing PUSCH repetition Type A

Parameter		BS type 1-O	BS type 2-O
Transform precoding		Disabled	
Default TDD UL-DL pattern (Note 1)		15 kHz SCS: 3D1S1U, S=10D:2G:2U 30 kHz SCS: 7D1S2U, S=6D:4G:4U	60 kHz and 120 kHz SCS: 3D1S1U, S=10D:2G:2U
HARQ	Maximum number of HARQ transmissions	4	
	RV sequence	{0,3,0,3} (Note 2)	
DM-RS	DM-RS configuration type	1	
	DM-RS duration	single-symbol DM-RS	
	Additional DM-RS position	pos1	
	Number of DM-RS CDM group(s) without data	2	
	Ratio of PUSCH EPRE to DM-RS EPRE	-3 dB	
	DM-RS port(s)	{0}, {0,1}	
	DM-RS sequence generation	$N_{ID}^0=0, n_{SCID}=0$	
Time domain resource assignment	PUSCH mapping type	A, B	B
	Start symbol	0	0
	Allocation length	14	10
	PUSCH aggregation factor	15 KHz SCS: n2 for FDD and n8 for TDD 30 KHz SCS: n2 (Note 3) (Note 5)	n8 (Note 4)
Frequency domain resource assignment	RB assignment	Full applicable test bandwidth	
	Frequency hopping	Disabled	
Code block group based PUSCH transmission		Disabled	Disabled
PTRS configuration	Frequency density ( $K_{PT-RS}$ )	N.A.	Disabled
	Time density ( $L_{PT-RS}$ )	N.A.	Disabled
<p>Note 1: The same requirements are applicable to TDD with different UL-DL patterns and different aggregation factor configurations under assumption that two effective transmissions of the transport block are generated for BS type 2-O.</p> <p>Note 2: The effective RV sequence is {0,2,3,1} with slot aggregation</p> <p>Note 3: The intention of this configuration is to have two effective transmissions of the transport block. To achieve this for the standard TDD pattern captured in this table, a value of n8 is necessary, while for FDD a value of n2 is necessary.</p> <p>Note 4: The intention of this configuration is to have two effective transmissions of the transport block. To achieve this for the standard TDD pattern captured in this table, a value of n8 is necessary.</p> <p>Note 5: PUSCH aggregation factor for 15 KHz SCS: The requirements for PUSCH with aggregation for 15 KHz can be tested either by configuring n8 and the DDSU TDD pattern or by configuring FDD with aggregation level n2.</p>			

- 6) The multipath fading emulators shall be configured according to the corresponding channel model defined in annex J.
- 7) Adjust the test signal mean power so the calibrated radiated SNR value at the BS receiver is as specified in clause 8.2.7.5.1 and clause 8.2.7.5.2 for *BS type 1-O* and *BS type 2-O* respectively, and that the SNR at the BS receiver is not impacted by the noise floor.

The power level for the transmission may be set such that the AWGN level at the RIB is equal to the AWGN level in table 8.2.7.4.2-2.

Table 8.2.7.4.2-2: AWGN power level at the BS input

BS type	Sub-carrier spacing (kHz)	Channel bandwidth (MHz)	AWGN power level
BS type 1-O (Note 4)	15	5	-86.5 - $\Delta_{\text{OTAREFSENS}}$ dBm / 4.5 MHz
		10	-83.3 - $\Delta_{\text{OTAREFSENS}}$ dBm / 9.36 MHz
	30	10	-83.6 - $\Delta_{\text{OTAREFSENS}}$ dBm / 8.64 MHz
		40	-77.2 - $\Delta_{\text{OTAREFSENS}}$ dBm / 38.16 MHz
BS type 2-O (Note 5)	60	50	$EIS_{\text{REFSENS\_50M}} + \Delta_{\text{FR2\_REFSENS}} + 15$ dBm / 47.52 MHz
		100	$EIS_{\text{REFSENS\_50M}} + \Delta_{\text{FR2\_REFSENS}} + 18$ dBm / 95.04 MHz
	120	50	$EIS_{\text{REFSENS\_50M}} + \Delta_{\text{FR2\_REFSENS}} + 15$ dBm / 46.08 MHz
		100	$EIS_{\text{REFSENS\_50M}} + \Delta_{\text{FR2\_REFSENS}} + 18$ dBm / 95.04 MHz
<p>NOTE 1: <math>\Delta_{\text{OTAREFSENS}}</math> as declared in D.53 in table 4.6-1 and clause 7.1.</p> <p>NOTE 2: <math>\Delta_{\text{FR2\_REFSENS}} = -3</math> dB as described in clause 7.1, since the OTA REFSENS reference direction (as declared in D.54 in table 4.6-1) is used for testing.</p> <p>NOTE 3: <math>EIS_{\text{REFSENS\_50M}}</math> as declared in D.28 in table 4.6-1.</p> <p>NOTE 4: The AWGN power level contains an AWGN offset of 16dB by default. If needed for test purposes, the AWGN level can be reduced from the default by any value in the range 0dB to 16dB. Changing the AWGN level does not impact the validity of the test, as it reduces the effective base band SNR level.</p> <p>NOTE 5: The AWGN power level contains an AWGN offset of 15dB by default. If needed for test purposes, the AWGN level can be reduced from the default by any value in the range 0dB to 15dB. Changing the AWGN level does not impact the validity of the test, as it reduces the effective base band SNR level.</p>			

8) For reference channels applicable to the BS, measure the throughput.

## 8.2.7.5 Test Requirement

### 8.2.7.5.1 Test requirement for BS type 1-0

The block error probability (BLER) measured according to clause 8.2.7.4.2 shall not exceed 1% for the SNR levels specified in table 8.2.7.5.1-1 to table 8.2.7.5.1-8 for 1Tx.

Table 8.2.7.5.1-1: Test requirements for PUSCH, Type A, 5 MHz channel bandwidth, 15 kHz SCS

Number of TX antennas	Number of demodulation branches	Cyclic prefix	Propagation conditions and correlation matrix (annex J)	Target BLER	FRC (annex A)	Additional DM-RS position	SNR (dB)
1	2	Normal	TDLB100-400 Low	1% (Note 1)	G-FR1-A3A-1	pos1	-7.8
Note 1: BLER is defined as residual BLER; i.e. ratio of incorrectly received transport blocks / sent transport blocks, independently of the number HARQ transmission(s) for each transport block.							

Table 8.2.7.5.1-2: Test requirements for PUSCH, Type A, 10 MHz channel bandwidth, 15 kHz SCS

Number of TX antennas	Number of demodulation branches	Cyclic prefix	Propagation conditions and correlation matrix (annex J)	Target BLER	FRC (annex A)	Additional DM-RS position	SNR (dB)
1	2	Normal	TDLB100-400 Low	1% (Note 1)	G-FR1-A3A-2	pos1	-9.6
Note 1: BLER is defined as residual BLER; i.e. ratio of incorrectly received transport blocks / sent transport blocks, independently of the number HARQ transmission(s) for each transport block.							

**Table 8.2.7.5.1-3: Test requirements for PUSCH, Type A, 10 MHz channel bandwidth, 30 kHz SCS**

Number of TX antennas	Number of demodulation branches	Cyclic prefix	Propagation conditions and correlation matrix (annex J)	Target BLER	FRC (annex A)	Additional DM-RS position	SNR (dB)
1	2	Normal	TDLB100-400 Low	1% (Note 1)	G-FR1-A3A-3	pos1	-10.2
Note 1: BLER is defined as residual BLER; i.e. ratio of incorrectly received transport blocks / sent transport blocks, independently of the number HARQ transmission(s) for each transport block.							

**Table 8.2.7.5.1-4: Test requirements for PUSCH, Type A, 40 MHz channel bandwidth, 30 kHz SCS**

Number of TX antennas	Number of demodulation branches	Cyclic prefix	Propagation conditions and correlation matrix (annex J)	Target BLER	FRC (annex A)	Additional DM-RS position	SNR (dB)
1	2	Normal	TDLB100-400 Low	1% (Note 1)	G-FR1-A3A-4	pos1	-10.9
Note 1: BLER is defined as residual BLER; i.e. ratio of incorrectly received transport blocks / sent transport blocks, independently of the number HARQ transmission(s) for each transport block.							

**Table 8.2.7.5.1-5: Test requirements for PUSCH, Type B, 5 MHz channel bandwidth, 15 kHz SCS**

Number of TX antennas	Number of demodulation branches	Cyclic prefix	Propagation conditions and correlation matrix (annex J)	Target BLER	FRC (annex A)	Additional DM-RS position	SNR (dB)
1	2	Normal	TDLB100-400 Low	1% (Note 1)	G-FR1-A3A-1	pos1	-7.6
Note 1: BLER is defined as residual BLER; i.e. ratio of incorrectly received transport blocks / sent transport blocks, independently of the number HARQ transmission(s) for each transport block.							

**Table 8.2.7.5.1-6: Test requirements for PUSCH, Type B, 10 MHz channel bandwidth, 15 kHz SCS**

Number of TX antennas	Number of demodulation branches	Cyclic prefix	Propagation conditions and correlation matrix (annex J)	Target BLER	FRC (annex A)	Additional DM-RS position	SNR (dB)
1	2	Normal	TDLB100-400 Low	1% (Note 1)	G-FR1-A3A-2	pos1	-9.5
Note 1: BLER is defined as residual BLER; i.e. ratio of incorrectly received transport blocks / sent transport blocks, independently of the number HARQ transmission(s) for each transport block.							

**Table 8.2.7.5.1-7: Test requirements for PUSCH, Type B, 10 MHz channel bandwidth, 30 kHz SCS**

Number of TX antennas	Number of demodulation branches	Cyclic prefix	Propagation conditions and correlation matrix (annex J)	Target BLER	FRC (annex A)	Additional DM-RS position	SNR (dB)
1	2	Normal	TDLB100-400 Low	1% (Note 1)	G-FR1-A3A-3	pos1	-10.2
Note 1: Calculate the target BLER after all HARQ transmission(s) for one TB.							

**Table 8.2.7.5.1-8: Test requirements for PUSCH, Type B, 40 MHz channel bandwidth, 30 kHz SCS**

Number of TX antennas	Number of demodulation branches	Cyclic prefix	Propagation conditions and correlation matrix (annex J)	Target BLER	FRC (annex A)	Additional DM-RS position	SNR (dB)
1	2	Normal	TDLB100-400 Low	1% (Note 1)	G-FR1-A3A-4	pos1	-10.8
Note 1: Calculate the target BLER after all HARQ transmission(s) for one TB.							



NOTE: If the above Test Requirement differs from the Minimum Requirement then the Test Tolerance applied for this test is non-zero. The Test Tolerance for this test and the explanation of how the Minimum Requirement has been relaxed by the Test Tolerance is given in annex C.

### 8.2.7.5.2 Test requirement for *BS type 2-0*

The block error probability (BLER) measured according to clause 8.2.7.4.2 shall not exceed 1% for the SNR levels specified in table 8.2.7.5.2-1 to 8.2.7.5.2-7.

**Table 8.2.7.5.2-1: Test requirements for PUSCH with 1% BLER, 50 MHz Channel Bandwidth, 60 kHz SCS**

Number of TX antennas	Number of demodulation branches	Cyclic prefix	Propagation conditions and correlation matrix (annex J)	BLER	FRC (annex A)	Additional DM-RS position	PT-RS	SNR (dB)
1	2	Normal	TDLA30-300 Low	1 %	G-FR2-A3A-5	pos1	No	-11.3

**Table 8.2.7.5.2-2: Test requirements for PUSCH with 1% BLER, 100 MHz Channel Bandwidth, 60 kHz SCS**

Number of TX antennas	Number of demodulation branches	Cyclic prefix	Propagation conditions and correlation matrix (annex J)	BLER	FRC (annex A)	Additional DM-RS position	PT-RS	SNR (dB)
1	2	Normal	TDLA30-300 Low	1 %	G-FR2-A3A-6	pos1	No	-11.6

**Table 8.2.7.5.2-3: Test requirements for PUSCH with 1% BLER, 50 MHz Channel Bandwidth, 120 kHz SCS**

Number of TX antennas	Number of demodulation branches	Cyclic prefix	Propagation conditions and correlation matrix (annex J)	BLER	FRC (annex A)	Additional DM-RS position	PT-RS	SNR (dB)
1	2	Normal	TDLA30-300 Low	1 %	G-FR2-A3A-7	pos1	No	-10.6

**Table 8.2.7.5.2-4: Test requirements for PUSCH with 1% BLER, 100 MHz Channel Bandwidth, 120 kHz SCS**

Number of TX antennas	Number of demodulation branches	Cyclic prefix	Propagation conditions and correlation matrix (annex J)	BLER	FRC (annex A)	Additional DM-RS position	PT-RS	SNR (dB)
1	2	Normal	TDLA30-300 Low	1 %	G-FR2-A3A-8	pos1	No	-11.1

NOTE: If the above Test Requirement differs from the Minimum Requirement then the Test Tolerance applied for this test is non-zero. The Test Tolerance for this test and the explanation of how the Minimum Requirement has been relaxed by the Test Tolerance is given in annex C.

## 8.2.8 Performance requirements for PUSCH mapping Type B with non-slot transmission

### 8.2.8.1 Definition and applicability

The performance requirement of PUSCH mapping type B with non-slot transmission is determined by a minimum required throughput for a given SNR. The required throughput is expressed as a fraction of maximum throughput for the FRCs listed in annex A.

Which specific test(s) are applicable to BS is based on the test applicability rules defined in clause 8.1.2.1.

### 8.2.8.2 Minimum Requirement

For *BS type 1-O*, the minimum requirement is in TS 38.104 [2], clause 11.2.1.8.

For *BS type 2-O*, the minimum requirement is in TS 38.104 [2], clause 11.2.2.5.

### 8.2.8.3 Test purpose

The test shall verify the receiver's ability to achieve throughput under scenarios with non-slot PUSCH Type B transmission for a given SNR.

### 8.2.8.4 Method of test

#### 8.2.8.4.1 Initial conditions

Test environment: Normal, see annex B.2.

RF channels to be tested for single carrier:  $M$ , see clause 4.9.1.

RF channels to be tested for carrier aggregation:  $M_{\text{BW Channel CA}}$ ; see clause 4.9.1.

Direction to be tested: OTA REFSSENS *receiver target reference direction* (see D.54 in table 4.6-1).

#### 8.2.8.4.2 Procedure

- 1) Place the BS with its manufacturer declared coordinate system reference point in the same place as calibrated point in the test system, as shown in annex E.3.
- 2) Align the manufacturer declared coordinate system orientation of the BS with the test system.
- 3) Set the BS in the declared direction to be tested.
- 4) Connect the BS tester generating the wanted signal, multipath fading simulators and AWGN generators to a test antenna via a combining network in OTA test setup, as shown in annex E.3. Each of the demodulation branch signals should be transmitted on one polarization of the test antenna(s).
- 5) The characteristics of the wanted signal shall be configured according to the corresponding UL reference measurement channel defined in annex A, and according to additional test parameters listed in table 8.2.8.4.2-1.

Table 8.2.8.4.2-1: Test parameters for testing PUSCH

Parameter		BS type 1-O	BS type 2-O
Transform precoding		Disabled	
Default TDD UL-DL pattern (Note 1)		15 kHz SCS: 3D1S1U, S=10D:2G:2U 30 kHz SCS: 7D1S2U, S=6D:4G:4U	60 kHz and 120 kHz SCS: 3D1S1U, S=10D:2G:2U
HARQ	Maximum number of HARQ transmissions	1	
	RV sequence	0	
DM-RS	DM-RS configuration type	1	
	DM-RS duration	single-symbol DM-RS	
	Additional DM-RS position	pos0	pos0
	Number of DM-RS CDM group(s) without data	2	
	Ratio of PUSCH EPRE to DM-RS EPRE	-3 dB	
	DM-RS port(s)	{0}	
	DM-RS sequence generation	$N_{ID}^0=0, n_{SCID}=0$	
Time domain resource assignment	PUSCH mapping type	B	B
	Start symbol	0	0
	Allocation length	2	4
Frequency domain resource assignment	RB assignment	Full applicable test bandwidth	
	Frequency hopping	Disabled	
TPMI index for 2Tx two layer spatial multiplexing transmission		0	
Code block group based PUSCH transmission		Disabled	
PTRS configuration	Frequency density ( $K_{PT-RS}$ )	N.A.	Disabled
	Time density ( $L_{PT-RS}$ )	N.A.	Disabled
Note 1: The same requirements are applicable to FDD and TDD with different UL-DL patterns for BS type 1-O, and the same requirements are applicable to TDD with different UL-DL patterns for BS type 2-O.			

- 6) The multipath fading emulators shall be configured according to the corresponding channel model defined in annex J.
- 7) Adjust the test signal mean power so the calibrated radiated SNR value at the BS receiver is as specified in clause 8.2.8.5.1 and 8.2.8.5.2 for *BS type 1-O* and *BS type 2-O* respectively, and that the SNR at the BS receiver is not impacted by the noise floor.

The power level for the transmission may be set such that the AWGN level at the RIB is equal to the AWGN level in table 8.2.8.4.2-2.

Table 8.2.8.4.2-2: AWGN power level at the BS input

BS type	Sub-carrier spacing (kHz)	Channel bandwidth (MHz)	AWGN power level
BS type 1-O (Note 4)	15	5	-86.5 - $\Delta_{\text{OTAREFSENS}}$ dBm / 4.5 MHz
		10	-83.3 - $\Delta_{\text{OTAREFSENS}}$ dBm / 9.36 MHz
	30	10	-83.6 - $\Delta_{\text{OTAREFSENS}}$ dBm / 8.64 MHz
		40	-77.2 - $\Delta_{\text{OTAREFSENS}}$ dBm / 38.16 MHz
BS type 2-O (Note 5)	60	50	$E_{\text{ISREFSENS\_50M}} + \Delta_{\text{FR2\_REFSENS}} + 15$ dBm / 47.52 MHz
		100	$E_{\text{ISREFSENS\_50M}} + \Delta_{\text{FR2\_REFSENS}} + 18$ dBm / 95.04 MHz
	120	50	$E_{\text{ISREFSENS\_50M}} + \Delta_{\text{FR2\_REFSENS}} + 15$ dBm / 46.08 MHz
		100	$E_{\text{ISREFSENS\_50M}} + \Delta_{\text{FR2\_REFSENS}} + 18$ dBm / 95.04 MHz
<p>NOTE 1: <math>\Delta_{\text{OTAREFSENS}}</math> as declared in D.53 in table 4.6-1 and clause 7.1.</p> <p>NOTE 2: <math>\Delta_{\text{FR2\_REFSENS}} = -3</math> dB as described in clause 7.1, since the OTA REFSENS reference direction (as declared in D.54 in table 4.6-1) is used for testing.</p> <p>NOTE 3: <math>E_{\text{ISREFSENS\_50M}}</math> as declared in D.28 in table 4.6-1.</p> <p>NOTE 4: The AWGN power level contains an AWGN offset of 16dB by default. If needed for test purposes, the AWGN level can be reduced from the default by any value in the range 0dB to 16dB. Changing the AWGN level does not impact the validity of the test, as it reduces the effective base band SNR level.</p> <p>NOTE 5: The AWGN power level contains an AWGN offset of 15dB by default. If needed for test purposes, the AWGN level can be reduced from the default by any value in the range 0dB to 15dB. Changing the AWGN level does not impact the validity of the test, as it reduces the effective base band SNR level.</p>			

8) For reference channels applicable to the BS, measure the throughput.

## 8.2.8.5 Test Requirement

### 8.2.8.5.1 Test requirement for BS type 1-0

The throughput measured according to clause 8.2.8.4.2 shall not be below the limits for the SNR levels specified in table 8.2.8.5.1-1 to table 8.2.8.5.1-4 for 1Tx.

Table 8.2.8.5.1-1: Test requirements for PUSCH, Type B, 5 MHz channel bandwidth, 15 kHz SCS

Number of TX antennas	Number of demodulation branches	Cyclic prefix	Propagation conditions and correlation matrix (annex J)	Fraction of maximum throughput	FRC (annex A)	Additional DM-RS position	SNR (dB)
1	2	Normal	TDLC300-100 Low	70%	G-FR1-A3B-1	pos0	1.1

Table 8.2.8.5.1-2: Test requirements for PUSCH, Type B, 10 MHz channel bandwidth, 15 kHz SCS

Number of TX antennas	Number of demodulation branches	Cyclic prefix	Propagation conditions and correlation matrix (annex J)	Fraction of maximum throughput	FRC (annex A)	Additional DM-RS position	SNR (dB)
1	2	Normal	TDLC300-100 Low	70%	G-FR1-A3B-2	pos0	0.9

**Table 8.2.8.5.1-3: Test requirements for PUSCH, Type B, 10 MHz channel bandwidth, 30 kHz SCS**

Number of TX antennas	Number of demodulation branches	Cyclic prefix	Propagation conditions and correlation matrix (annex J)	Fraction of maximum throughput	FRC (annex A)	Additional DM-RS position	SNR (dB)
1	2	Normal	TDLC300-100 Low	70%	G-FR1-A3B-3	pos0	0.9

**Table 8.2.8.5.1-4: Test requirements for PUSCH, Type B, 40 MHz channel bandwidth, 30 kHz SCS**

Number of TX antennas	Number of demodulation branches	Cyclic prefix	Propagation conditions and correlation matrix (annex J)	Fraction of maximum throughput	FRC (annex A)	Additional DM-RS position	SNR (dB)
1	2	Normal	TDLC300-100 Low	70%	G-FR1-A3B-4	pos0	0.6

NOTE: If the above Test Requirement differs from the Minimum Requirement then the Test Tolerance applied for this test is non-zero. The Test Tolerance for this test and the explanation of how the Minimum Requirement has been relaxed by the Test Tolerance is given in annex C.

### 8.2.8.5.2 Test requirement for *BS type 2-0*

The throughput measured according to clause 8.2.8.4.2 shall not be below the limits for the SNR levels specified in table 8.2.8.5.2-1 to 8.2.8.5.2-4 for 1Tx.

**Table 8.2.8.5.2-1: Test requirements for PUSCH with 70% of maximum throughput, 50 MHz Channel Bandwidth, 60 kHz SCS**

Number of TX antennas	Number of demodulation branches	Cyclic prefix	Propagation conditions and correlation matrix (annex J)	Fraction of maximum throughput	FRC (annex A)	Additional DM-RS position	PT-RS	SNR (dB)
1	2	Normal	TDLA30-300 Low	70 %	G-FR2-A3A-1	pos0	No	-3.8

**Table 8.2.8.5.2-2: Test requirements for PUSCH with 70% of maximum throughput, 100 MHz Channel Bandwidth, 60 kHz SCS**

Number of TX antennas	Number of demodulation branches	Cyclic prefix	Propagation conditions and correlation matrix (annex J)	Fraction of maximum throughput	FRC (annex A)	Additional DM-RS position	PT-RS	SNR (dB)
1	2	Normal	TDLA30-300 Low	70 %	G-FR2-A3A-2	pos0	No	-4.4

**Table 8.2.8.5.2-3: Test requirements for PUSCH with 70% of maximum throughput, 50 MHz Channel Bandwidth, 120 kHz SCS**

Number of TX antennas	Number of demodulation branches	Cyclic prefix	Propagation conditions and correlation matrix (annex J)	Fraction of maximum throughput	FRC (annex A)	Additional DM-RS position	PT-RS	SNR (dB)
1	2	Normal	TDLA30-300 Low	70 %	G-FR2-A3A-3	pos0	No	-3.5

**Table 8.2.8.5.2-4: Test requirements for PUSCH with 70% of maximum throughput, 100 MHz Channel Bandwidth, 120 kHz SCS**

Number of TX antennas	Number of demodulation branches	Cyclic prefix	Propagation conditions and correlation matrix (annex J)	Fraction of maximum throughput	FRC (annex A)	Additional DM-RS position	PT-RS	SNR (dB)
1	2	Normal	TDLA30-300 Low	70 %	G-FR2-A3A-4	pos0	No	-4.5

NOTE: If the above Test Requirement differs from the Minimum Requirement then the Test Tolerance applied for this test is non-zero. The Test Tolerance for this test and the explanation of how the Minimum Requirement has been relaxed by the Test Tolerance is given in annex C.

## 8.2.9 Performance requirements for MsgA PUSCH

### 8.2.9.1 Definition and applicability

The performance requirement of MsgA PUSCH is determined by a maximum allowed block error rate of MsgA received by BS at given SNR for FRCs listed in annex A. The performance requirements assume that the precedent preamble of MsgA is correctly detection. The performance requirements of assume no HARQ retransmission.

These requirements are applicable for wide area and medium range BS that support 2-step RA type. The requirements are not applied for a local area BS that supports 2-step RA type.

Which specific test(s) are applicable to BS is based on the test applicability rules defined in clause 8.1.2.1.

### 8.2.9.2 Minimum Requirement

For *BS type 1-O*, the minimum requirement is in TS 38.104 [2] clause 11.2.1.9.

For *BS type 2-O*, the minimum requirement is in TS 38.104 [2] clause 11.2.1.4.

### 8.2.9.3 Test Purpose

The test shall verify the receiver's ability to detect MsgA PUSCH under multipath fading propagation conditions for a given SNR.

### 8.2.9.4 Method of test

#### 8.2.9.4.1 Initial Conditions

Test environment: Normal, see annex B.2.

RF channels to be tested: M; see clause 4.9.1.

RF channels to be tested for carrier aggregation:  $M_{\text{BW Channel CA}}$ ; see clause 4.9.1.

Direction to be tested: OTA REFSENS *receiver target reference direction* (see D.54 in table 4.6-1).

#### 8.2.9.4.2 Procedure

- 1) Place the BS with its manufacturer declared coordinate system reference point in the same place as calibrated point in the test system, as shown in annex E.3.
- 2) Align the manufacturer declared coordinate system orientation of the BS with the test system.
- 3) Set the BS in the declared direction to be tested.
- 4) Connect the BS tester generating the wanted signal, multipath fading simulators and AWGN generators to a test antenna via a combining network in OTA test setup, as shown in annex E.3. Each of the demodulation branch signals should be transmitted on one polarization of the test antenna(s).

- 5) The characteristics of the wanted signal shall be configured according to the corresponding UL reference measurement channel defined in annex A, and according to additional test parameters listed in table 8.2.9.4.2-1.

**Table 8.2.9.4.2-1: Test parameters for testing MsgA PUSCH for 2-step RA type**

Parameter		BS type 1-O	BS type 2-O
Preamble format		Free choice	
Transform precoding		Disable	
Power offset between preamble and MsgA(Note 1)		Free choice	
Default TDD UL-DL pattern(Note 2)		15 kHz SCS: 3D1S1U, S=10D:2G:2U 30 kHz SCS: 7D1S2U, S=6D:4G:4U	60 kHz and 120 kHz SCS: 3D1S1U, S=10D:2G:2U
HARQ	Maximum number of HARQ transmissions	1	
	RV sequence	0	
DM-RS	DM-RS configuration type	1	
	DM-RS duration	single-symbol DM-RS	
	Additional DM-RS position	Pos 1 or Pos 2 (Note 3)	Pos1
	Number of DM-RS CDM group(s) without data	2	
	Ratio of PUSCH EPRE to DM-RS EPRE	-3 dB	
	DM-RS port(s)	0	
	DM-RS sequence generation	$N_{ID}^0=0$ , group hopping and sequence hopping are disabled	
Time domain resource assignment	PUSCH mapping type	A, B	B
	Start symbol	0	0
	Allocation length	14	10
Frequency domain resource assignment	RB assignment	2	2
	Starting PRB index	0	0
	Frequency hopping	Disabled	
Code block group based PUSCH transmission		Disabled	
PT-RS		Not configured	
Timing offset (TO) Cycling (us)		15 kHz SCS: 0:0.2:3.8 30 kHz SCS: 0:0.1:2	60 kHz SCS: 0:0.1:0.6 120 kHz SCS: 0:0.1:0.5
NOTE1: The power ratio between preamble and msgA is set to be sufficient to achieve 100% preamble detection. The SNR for the requirement is defined on the msgA PUSCH			
NOTE 2: The same requirements are applicable to FDD and TDD with different UL-DL patterns			
NOTE 3: For FR1, either pos 1 or pos 2 may be used for the test FRC. A pass with either of these possibilities is sufficient to demonstrate compliance to the core requirement.			

- 6) The channel emulators shall be configured according to the corresponding channel model defined in annex J. Unless stated otherwise, the MIMO correlation matrices for the gNB are defined in annex J.2.3 for low correlation.
- 7) Adjust the test signal mean power so the calibrated radiated SNR value at the BS receiver is as specified in clause 8.2.9.5.1 and 8.2.9.5.2 for *BS type 1-O* and *BS type 2-O* respectively, and that the SNR at the BS receiver is not impacted by the noise floor.

The power level for the transmission may be set such that the AWGN level at the RIB is equal to the AWGN level in table 8.2.9.4.2-2.

Table 8.2.9.4.2-2: AWGN power level at the BS input

BS type	Sub-carrier spacing (kHz)	Channel bandwidth (MHz)	AWGN power level
BS type 1-O (Note 4)	15	10	-83.3 - $\Delta_{OTAREFSENS}$ dBm / 9.36 MHz
	30	40	-77.2 - $\Delta_{OTAREFSENS}$ dBm / 38.16 MHz
BS type 2-O (Note 5)	60	50	$EIS_{REFSENS\_50M} + \Delta_{FR2\_REFSENS} + 15$ dBm / 47.52MHz
	120	100	$EIS_{REFSENS\_50M} + \Delta_{FR2\_REFSENS} + 18$ dBm / 95.04 MHz

NOTE 1:  $\Delta_{OTAREFSENS}$  as declared in D.53 in table 4.6-1 and clause 7.1.  
 NOTE 2:  $\Delta_{FR2\_REFSENS} = -3$  dB as described in clause 7.1, since the OTA REFSSENS reference direction (as declared in D.54 in table 4.6-1) is used for testing.  
 NOTE 3:  $EIS_{REFSENS\_50M}$  as declared in D.28 in table 4.6-1.  
 NOTE 4: The AWGN power level contains an AWGN offset of 16dB by default. If needed for test purposes, the AWGN level can be reduced from the default by any value in the range 0dB to 16dB. Changing the AWGN level does not impact the validity of the test, as it reduces the effective base band SNR level.  
 NOTE 5: The AWGN power level contains an AWGN offset of 15dB by default. If needed for test purposes, the AWGN level can be reduced from the default by any value in the range 0dB to 15dB. Changing the AWGN level does not impact the validity of the test, as it reduces the effective base band SNR level.

8) The test signal generator sends a MsgA including a preamble and PUSCH signal and the receiver tries to detect the MsgA signal contents. The MsgA signal is sent with timing offset as described below. The following statistics are collected: the number of incorrectly decoded MsgA PUSCH transmitted during the MsgA signal transmission.

The timing offset base value for MsgA signal with 15 kHz SCS is set to 0. This offset is increased within the loop, by adding in each step a value of 0.2 us for BS type 1-O with 15 kHz SCS, until the end of the tested range, which is 3.8 us. At the end of the testing range, the offset is reset to zero. The timing offset scheme for MsgA transmission is presented in Figure 8.2.9.4.2-1.

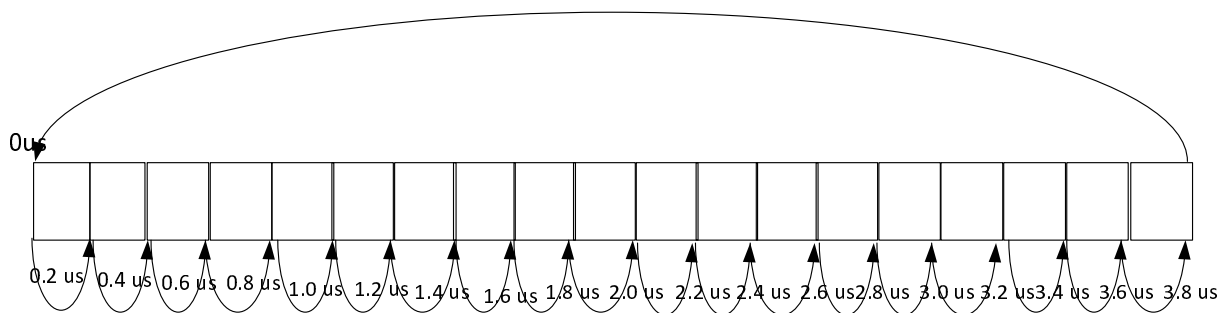
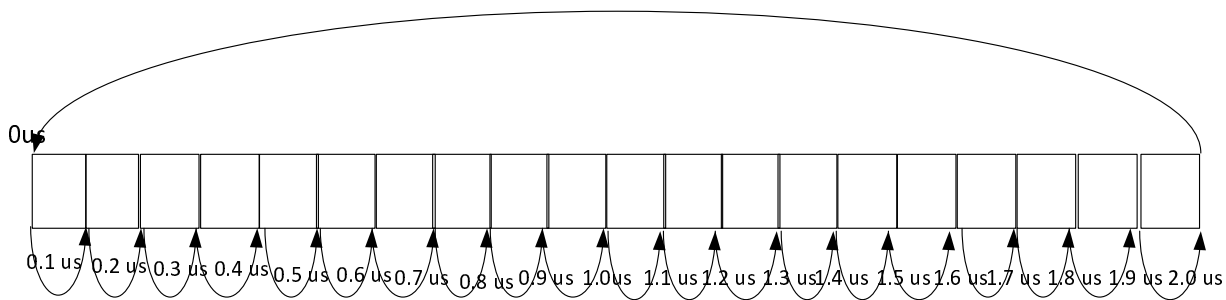

Figure 8.2.9.4.2-1: Timing offset scheme for MsgA transmission for BS type 1-O with 15 kHz SCS

The timing offset base value for MsgA signal with 30 kHz is set to 0. This offset is increased within the loop, by adding in each step a value of 0.1 us for BS type 1-O with 30 kHz SCS, until the end of the tested range, which is 2 us. At the end of the testing range, the offset is reset to zero. The timing offset scheme for MsgA transmission is presented in Figure 8.2.9.4.2-2.





**Figure 8.2.9.4.2-2: Timing offset scheme for MsgA transmission for BS type 1-O with 30 kHz SCS**

The timing offset base value for MsgA signal with 60 kHz is set to 0. This offset is increased within the loop, by adding in each step a value of 0.1 us for *BS type 2-O* with 60 kHz SCS, until the end of the tested range, which is 0.6 us. At the end of the testing range, the offset is reset to zero. The timing offset scheme for MsgA transmission is presented in Figure 8.2.9.4.2-3.

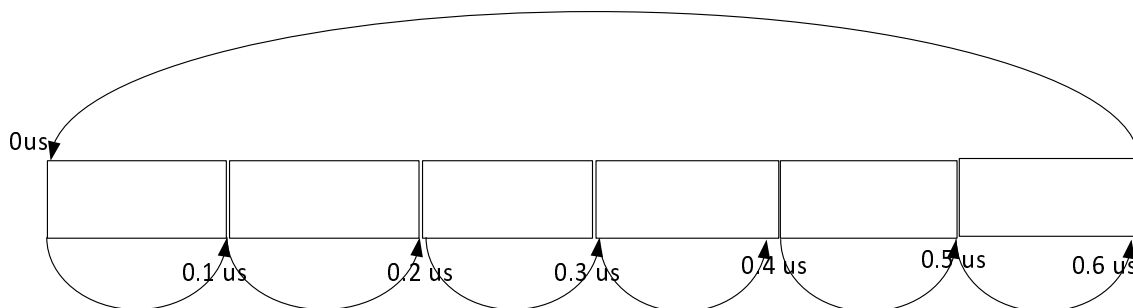

**Figure 8.2.9.4.2-3: Timing offset scheme for MsgA transmission for BS type 2-O with 60 kHz SCS**

The timing offset base value for MsgA signal with 120 kHz is set to 0. This offset is increased within the loop, by adding in each step a value of 0.1 us for *BS type 2-O* with 120 kHz SCS, until the end of the tested range, which is 0.5 us. At the end of the testing range, the offset is reset to zero. The timing offset scheme for MsgA transmission is presented in Figure 8.2.9.4.2-4.

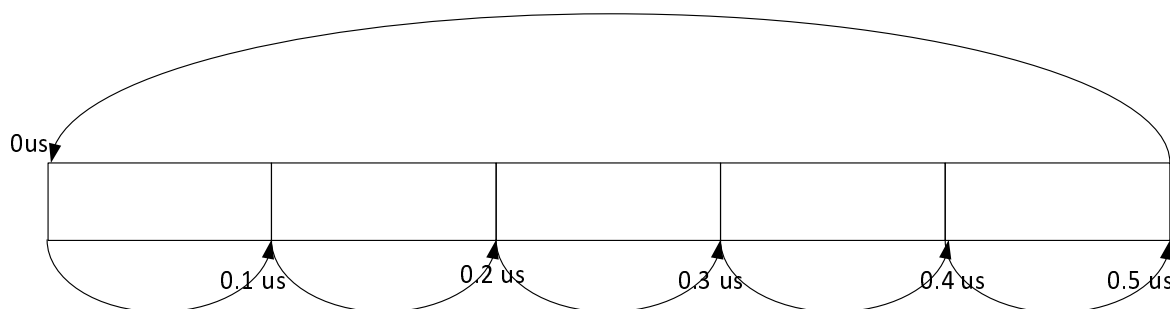

**Figure 8.2.9.4.2-4: Timing offset scheme for MsgA transmission for BS type 2-O with 120 kHz SCS**

### 8.2.9.5 Test Requirement

#### 8.2.9.5.1 Test Requirement for *BS type 1-O*

The block error rate of MsgA PUSCH for the reference measurement channel as specified in Annex A at the SNR given in table 8.2.9.5.1-1 to table 8.2.9.5.1-4 shall not exceed 1%.

**Table 8.2.9.5.1-1: Test requirements for MsgA PUSCH for 2-step RA type, Type A, 15 kHz SCS**

Number of TX antennas	Number of RX demodulation branches	Cyclic prefix	Propagation conditions (Annex J)	BLER	FRC (Annex A)	Time offset (Note 1)	SNR (dB)
1	2	Normal	TDLC300-100	1%	G-FR1-A8-1, or G-FR1-A8-3	0, 0.2, 3.8	7.9
Note 1: The time offset values are described as X, Y, Z where X is the first TO value, Y is the step in which the TO should be incremented, and Z is the largest TO value in the range.							

**Table 8.2.9.5.1-2: Test requirements for MsgA PUSCH for 2-step RA type, Type A, 30 kHz SCS**

Number of TX antennas	Number of RX demodulation branches	Cyclic prefix	Propagation conditions (Annex J)	BLER	FRC (Annex A)	Time offset (Note 1)	SNR (dB)
1	2	Normal	TDLC300-100	1%	G-FR1-A8-2, or G-FR1-A8-4	0, 0.1, 2.0	7.7
Note 1: The time offset values are described as X, Y, Z where X is the first TO value, Y is the step in which the TO should be incremented, and Z is the largest TO value in the range.							

**Table 8.2.9.5.1-3: Test requirements for MsgA PUSCH for 2-step RA type, Type B, 15 kHz SCS**

Number of TX antennas	Number of RX demodulation branches	Cyclic prefix	Propagation conditions (Annex J)	BLER	FRC (Annex A)	Time offset (Note 1)	SNR (dB)
1	2	Normal	TDLC300-100	1%	G-FR1-A8-1, or G-FR1-A8-3	0, 0.2, 3.8	7.6
Note 1: The time offset values are described as X, Y, Z where X is the first TO value, Y is the step in which the TO should be incremented, and Z is the largest TO value in the range.							

**Table 8.2.9.5.1-4: Test requirements for MsgA PUSCH for 2-step RA type, Type B, 30 kHz SCS**

Number of TX antennas	Number of RX demodulation branches	Cyclic prefix	Propagation conditions (Annex J)	BLER	FRC (Annex A)	Time offset (Note 1)	SNR (dB)
1	2	Normal	TDLC300-100	1%	G-FR1-A8-2, or G-FR1-A8-4	0, 0.1, 2.0	8.2
Note 1: The time offset values are described as X, Y, Z where X is the first TO value, Y is the step in which the TO should be incremented, and Z is the largest TO value in the range.							

### 8.2.9.5.2 Test Requirement for *BS type 2-0*

The block error rate of MsgA PUSCH for the reference measurement channel as specified in Annex A at the SNR given in table 8.2.9.5.2-1 to table 8.2.9.5.2-2 shall not exceed 1%.

**Table 8.2.9.5.2-1: Test requirements for MsgA PUSCH for 2-step RA type, Type B, 60 kHz SCS**

Number of TX antennas	Number of RX demodulation branches	Cyclic prefix	Propagation conditions (Annex J)	BLER	FRC (Annex A)	Time offset (Note 1)	SNR (dB)
1	2	Normal	TDLA30-300	1%	G-FR2-A3-25	0, 0.1, 0.6	9.3
Note 1: The time offset values are described as X, Y, Z where X is the first TO value, Y is the step in which the TO should be incremented, and Z is the largest TO value in the range.							

**Table 8.2.9.5.2-2: Test requirements for MsgA PUSCH for 2-step RA type, Type B, 120 kHz SCS**

Number of TX antennas	Number of RX demodulation branches	Cyclic prefix	Propagation conditions (Annex J)	BLER	FRC (Annex A)	Time offset (Note 1)	SNR (dB)
1	2	Normal	TDLA30-300	1%	G-FR2-A3-26	0, 0.1, 0.5	8.9
Note 1: The time offset values are described as X, Y, Z where X is the first TO value, Y is the step in which the TO should be incremented, and Z is the largest TO value in the range.							

## 8.2.10 Requirements for interlaced PUSCH

### 8.2.10.1 Definition and applicability

The performance requirement of PUSCH with interlace allocation is determined by a minimum required throughput for a given SNR. The required throughput is expressed as a fraction of maximum throughput for the FRCs listed in annex A. The performance requirements assume HARQ retransmissions.

Which specific test(s) are applicable to BS is based on the test applicability rules defined in clause 8.1.2.5.

### 8.2.10.2 Minimum Requirement

For *BS type 1-O*, the minimum requirement is in TS 38.104 [2], clause 11.2.1.1.

For *BS type 2-O*, no requirement and no test are defined.

### 8.2.10.3 Test Purpose

The test shall verify the receiver's ability to achieve throughput under multipath fading propagation conditions for a given SNR.

### 8.2.10.4 Method of test

#### 8.2.10.4.1 Initial Conditions

Test environment: Normal, see annex B.2.

RF channels to be tested for single carrier: M, see clause 4.9.1.

RF channels to be tested for carrier aggregation:  $M_{\text{BW Channel CA}}$ ; see clause 4.9.1.

Direction to be tested: OTA REFSSENS *receiver target reference direction* (see D.54 in table 4.6-1).

## 8.2.10.4.2 Procedure

- 1) Place the BS with its manufacturer declared coordinate system reference point in the same place as calibrated point in the test system, as shown in annex E.3.
- 2) Align the manufacturer declared coordinate system orientation of the BS with the test system.
- 3) Set the BS in the declared direction to be tested.
- 4) Connect the BS tester generating the wanted signal, multipath fading simulators and AWGN generators to a test antenna via a combining network in OTA test setup, as shown in annex E.3. Each of the demodulation branch signals should be transmitted on one polarization of the test antenna(s).
- 5) The characteristics of the wanted signal shall be configured according to the corresponding UL reference measurement channel defined in annex A, and according to additional test parameters listed in table 8.2.10.4.2-1.

Table 8.2.10.4.2-1: Test parameters for testing PUSCH

Parameter		Value
BS type		BS type 1-O
Transform precoding		Disabled
Default TDD UL-DL pattern (Note 1)		15 kHz SCS: 3D1S1U, S=10D:2G:2U 30 kHz SCS: 7D1S2U, S=6D:4G:4U
HARQ	Maximum number of HARQ transmissions	4
	RV sequence	0, 2, 3, 1
DM-RS	DM-RS configuration type	1
	DM-RS duration	single-symbol DM-RS
	Additional DM-RS position	pos1
	Number of DM-RS CDM group(s) without data	2
	Ratio of PUSCH EPRE to DM-RS EPRE	-3 dB
	DM-RS port(s)	0
	DM-RS sequence generation	$N_{ID}^0=0$ , $n_{SCID}=0$
Time domain resource assignment	PUSCH mapping type	A, B
	Start symbol	0
	Allocation length	14
Frequency domain resource assignment	RB assignment	Full applicable test bandwidth. First interlace with RBs 0,10,20,...,100 are allocated for tests with 15 KHz and first interlace with RBs 0,5,10,...50 are allocated for tests with 30 KHz.
	Frequency hopping	Disabled
Code block group based PUSCH transmission		Disabled
NOTE 1: The same requirements are applicable to FDD and TDD with different UL-DL patterns.		

- 6) The multipath fading emulators shall be configured according to the corresponding channel model defined in annex J.
- 7) Adjust the test signal mean power so the calibrated radiated SNR value at the BS receiver is as specified in clause 8.2.10.5.1, and that the SNR at the BS receiver is not impacted by the noise floor.

The power level for the transmission may be set such that the AWGN level at the RIB is equal to the AWGN level in table 8.2.10.4.2-2.

Table 8.2.10.4.2-2: AWGN power level at the BS input

BS type	Sub-carrier spacing (kHz)	Channel bandwidth (MHz)	AWGN power level
1-O	15	20	$-80.2 - \Delta_{OTAREFSENS}$ dBm / 19.08 MHz
	30	20	$-80.4 - \Delta_{OTAREFSENS}$ dBm / 18.36 MHz

NOTE 1:  $\Delta_{OTAREFSENS}$  as declared in D.53 in table 4.6-1 and clause 7.1.  
 NOTE 2: The AWGN power level contains an AWGN offset of 16dB by default. If needed for test purposes, the AWGN level can be reduced from the default by any value in the range 0dB to 16dB. Changing the AWGN level does not impact the validity of the test, as it reduces the effective base band SNR level.

## 8.2.10.5 Test Requirement

### 8.2.10.5.1 Test requirement for *BS type 1-0*

The throughput measured according to clause 8.2.10.4.2 shall not be below the limits for the SNR levels specified in table 8.2.10.5-1.

**Table 8.2.10.5-1: Minimum requirements for PUSCH with 70% of maximum throughput, Type A, 20 MHz channel bandwidth, 15 kHz SCS**

Number of TX antennas	Number of demodulation branches	Cyclic prefix	Propagation conditions and correlation matrix (Annex J)	Fraction of maximum throughput	FRC (Annex A)	Additional DM-RS position	SNR (dB)
1	2	Normal	TDLA30-10 Low	70%	G-FR1-A5-15	pos1	12.9

**Table 8.2.10.5-2: Minimum requirements for PUSCH with 70% of maximum throughput, Type A, 20 MHz channel bandwidth, 30 kHz SCS**

Number of TX antennas	Number of demodulation branches	Cyclic prefix	Propagation conditions and correlation matrix (Annex J)	Fraction of maximum throughput	FRC (Annex A)	Additional DM-RS position	SNR (dB)
1	2	Normal	TDLA30-10 Low	70%	G-FR1-A5-16	pos1	12.8

**Table 8.2.10.5-3: Minimum requirements for PUSCH with 70% of maximum throughput, Type B, 20 MHz channel bandwidth, 15 kHz SCS**

Number of TX antennas	Number of demodulation branches	Cyclic prefix	Propagation conditions and correlation matrix (Annex J)	Fraction of maximum throughput	FRC (Annex A)	Additional DM-RS position	SNR (dB)
1	2	Normal	TDLA30-10 Low	70%	G-FR1-A5-15	pos1	12.9

**Table 8.2.10.5-4: Minimum requirements for PUSCH with 70% of maximum throughput, Type B, 20 MHz channel bandwidth, 30 kHz SCS**

Number of TX antennas	Number of demodulation branches	Cyclic prefix	Propagation conditions and correlation matrix (Annex J)	Fraction of maximum throughput	FRC (Annex A)	Additional DM-RS position	SNR (dB)
1	2	Normal	TDLA30-10 Low	70%	G-FR1-A5-16	pos1	12.8

NOTE: If the above Test Requirement differs from the Minimum Requirement then the Test Tolerance applied for this test is non-zero. The Test Tolerance for this test and the explanation of how the Minimum Requirement has been relaxed by the Test Tolerance is given in annex C.

## 8.2.11 Performance requirements for CG-UCI multiplexed on interlaced PUSCH

### 8.2.11.1 Definition and applicability

The performance requirement of CG-UCI multiplexed on interlaced PUSCH is determined by the parameter: block error probability (BLER) of CG-UCI. The performance is measured by the required SNR at block error probability of CG-UCI not exceeding 1 %.

The CG-UCI BLER is defined as the probability of incorrectly decoding the CG-UCI information when the CG-UCI information is sent.

In the test of UCI multiplexed on interlaced PUSCH, the UCI information only contains CG-UCI information, there is no HACK/ACK, CSI part 1 or CSI part 2 information transmitted.

The number of UCI information bit payload per slot is defined as 18 bits.

The 18 bits CG-UCI information is further defined with the bitmap [c0 c1 c2 ... c17] as follows:

- HARQ process number: [c0 c1 c2 c3] = [ 0 0 0 1]
- RV sequence: [c4 c5] = [0 0]
- NDI: [c6] = [1]
- COT sharing information field: [c7 c8 ... c17] = [0 0 0 0 0 0 0 0 0 0]

In the test, PUSCH data and CG-UCI are transmitted simultaneously.

Which specific test(s) is applicable to BS is based on the test applicability rule defined in clause 8.1.2.

### 8.2.11.2 Minimum Requirement

The minimum requirement is in TS 38.104 [2] clause 11.2.1.11.

### 8.2.11.3 Test purpose

The test shall verify the receiver's ability to detect UCI with CG-UCI multiplexed on interlaced PUSCH under multipath fading propagation conditions for a given SNR.

### 8.2.11.4 Method of test

#### 8.2.11.4.1 Initial conditions

Test environment: Normal; see annex B.2.

RF channels to be tested for single carrier: M; see clause 4.9.1

Direction to be tested: OTA REFSSENS *receiver target reference direction* (see D.54 in table 4.6-1).

#### 8.2.11.4.2 Procedure

- 1) Place the BS with its manufacturer declared coordinate system reference point in the same place as calibrated point in the test system, as shown in annex E.3.
- 2) Align the manufacturer declared coordinate system orientation of the BS with the test system.
- 3) Set the BS in the declared direction to be tested.
- 4) Connect the BS tester generating the wanted signal, multipath fading simulators and AWGN generators to a test antenna via a combining network in OTA test setup, as shown in annex E.3. Each of the demodulation branch signals should be transmitted on one polarization of the test antenna(s).

- 5) The characteristics of the wanted signal shall be configured to the corresponding UL reference measurement channel defined in annex A, and according to additional test parameters listed in table 8.2.11.4.2-1. The UCI information bit payload per slot is equal to 18 bits.

**Table: 8.2.11.4.2-1 Test parameters for testing CG-UCI multiplexed on interlaced PUSCH**

Parameter		Value
Transform precoding		Disabled
Default TDD UL-DL pattern		30 kHz SCS: 7D1S2U, S=6D:4G:4U  15 kHz SCS: 3D1S1U S=10D:2G:2U
HARQ	Maximum number of HARQ transmissions	1
	RV sequence	0
DM-RS	DM-RS configuration type	1
	DM-RS duration	Single-symbol DM-RS
	Additional DM-RS position	pos1
	Number of DM-RS CDM group(s) without data	2
	Ratio of PUSCH EPRE to DM-RS EPRE	-3 dB
	DM-RS port(s)	{0}
	DM-RS sequence generation	$N_{ID}^0=0, n_{SCID}=0$
Time domain resource assignment	PUSCH mapping type	A,B
	Start symbol	0
	Allocation length	14
Frequency domain resource assignment	RB assignment	Full applicable test bandwidth. First interlace with RBs 0,10,20,...,100 are allocated for tests with 15 KHz and first interlace with RBs 0,5,10,...50 are allocated for tests with 30 KHz.
	Frequency hopping	Disabled
Code block group based PUSCH transmission		Disabled
PT-RS		Disabled
UCI	Number of information bits	18
	scaling	1
	betaOffsetCG-UCI-Index1	8
	UCI partition for frequency hopping	Disabled

- 6) The multipath fading emulators shall be configured according to the corresponding channel model defined in annex J.
- 7) Adjust the test signal mean power so the calibrated radiated SNR value at the BS receiver is as specified in clause 8.2.11.5.1 and that the SNR at the BS receiver is not impacted by the noise floor.

The power level for the transmission may be set such that the AWGN level at the RIB is equal to the AWGN level in table 8.2.11.4.2-2.

**Table 8.2.11.4.2-2: AWGN power level at the BS input**

BS type	Sub-carrier spacing (kHz)	Channel bandwidth (MHz)	AWGN power level
BS type 1-O	15	20	$-80.2 - \Delta_{OTAREFSENS}$ dBm / 19.08 MHz
BS type 1-O	30	20	$-80.4 - \Delta_{OTAREFSENS}$ dBm / 18.36 MHz
NOTE: $\Delta_{OTAREFSENS}$ as declared in D.53 in table 4.6-1 and clause 7.1.			

- 8) The signal generators send a test pattern where CG-UCI information can be multiplexed on interlaced PUSCH. The following statistics are kept: the number of incorrectly decoded CG-UCI information transmitted during UCI multiplexed on interlaced PUSCH transmission.

## 8.2.11.5 Test Requirement

### 8.2.11.5.1 Test requirement for *BS type 1-O*

The fraction of incorrectly decoded CG-UCI according to clause 8.2.11.4.2 shall be less than 1 % for the SNR listed in table 8.2.11.5.1-1 to table 8.2.11.5.1-4.

**Table 8.2.11.5.1-1: Test requirements for CG-UCI multiplexed on interlaced PUSCH, Type A, 20 MHz channel bandwidth, 15 kHz SCS**

Number of TX antennas	Number of demodulation branches	Cyclic Prefix	Propagation conditions and correlation matrix (Annex J)	CG-UCI bits	Additional DM-RS position	FRC (Annex A)	SNR (dB)
1	2	Normal	TDLA30-10 Low	18	pos1	G-FR1-A5-15	5.2

**Table 8.2.11.5.1-2: Test requirements for CG-UCI multiplexed on interlaced PUSCH, Type A, 20 MHz channel bandwidth, 30 kHz SCS**

Number of TX antennas	Number of demodulation branches	Cyclic Prefix	Propagation conditions and correlation matrix (Annex J)	CG-UCI bits	Additional DM-RS position	FRC (Annex A)	SNR (dB)
1	2	Normal	TDLA30-10 Low	18	pos1	G-FR1-A5-16	5.3

**Table 8.2.11.5.1-3: Test requirements for CG-UCI multiplexed on interlaced PUSCH, Type B, 20 MHz channel bandwidth, 15 kHz SCS**

Number of TX antennas	Number of demodulation branches	Cyclic Prefix	Propagation conditions and correlation matrix (Annex J)	CG-UCI bits	Additional DM-RS position	FRC (Annex A)	SNR (dB)
1	2	Normal	TDLA30-10 Low	18	pos1	G-FR1-A5-15	5.2

**Table 8.2.11.5.1-4: Test requirements for CG-UCI multiplexed on interlaced PUSCH, Type B, 20 MHz channel bandwidth, 30 kHz SCS**

Number of TX antennas	Number of demodulation branches	Cyclic Prefix	Propagation conditions and correlation matrix (Annex J)	CG-UCI bits	Additional DM-RS position	FRC (Annex A)	SNR (dB)
1	2	Normal	TDLA30-10 Low	18	pos1	G-FR1-A5-16	5.6

## 8.2.12 Performance requirements for TB processing over multi-slot PUSCH (TBoMS)

### 8.2.12.1 Definition and applicability

The performance requirement of PUSCH TBoMS is determined by a minimum required throughput for a given SNR. The required throughput is expressed as a fraction of maximum throughput for the FRCs listed in annex A. The performance requirements assume HARQ retransmissions.

Which specific test(s) are applicable to BS is based on the test applicability rules defined in clause 8.1.2.8.

### 8.2.12.2 Minimum Requirement

For *BS type 1-O*, the minimum requirement is in TS 38.104 [2], clause 11.2.1.12.



For *BS type 2-O*, the minimum requirement is in TS 38.104 [2], clause 11.2.2.9.

### 8.2.12.3 Test Purpose

The test shall verify the receiver's ability to achieve throughput under multipath fading propagation conditions for a given SNR.

### 8.2.12.4 Method of test

#### 8.2.12.4.1 Initial Conditions

Test environment: Normal, see annex B.2.

RF channels to be tested for single carrier: M, see clause 4.9.1.

RF channels to be tested for carrier aggregation:  $M_{\text{BW Channel CA}}$ ; see clause 4.9.1.

Direction to be tested: OTA REFSENS *receiver target reference direction* (see D.54 in table 4.6-1).

#### 8.2.12.4.2 Procedure

- 1) Place the BS with its manufacturer declared coordinate system reference point in the same place as calibrated point in the test system, as shown in annex E.3.
- 2) Align the manufacturer declared coordinate system orientation of the BS with the test system.
- 3) Set the BS in the declared direction to be tested.
- 4) Connect the BS tester generating the wanted signal, multipath fading simulators and AWGN generators to a test antenna via a combining network in OTA test setup, as shown in annex E.3. Each of the demodulation branch signals should be transmitted on one polarization of the test antenna(s).
- 5) The characteristics of the wanted signal shall be configured according to the corresponding UL reference measurement channel defined in annex A, and according to additional test parameters listed in table 8.2.12.4.2-1.

Table: 8.2.12.4.2-1 Test parameters for testing PUSCH TBoMS

Parameter		BS type 1-O	BS type 2-O
Transform precoding		Disabled	Disabled
Default TDD UL-DL pattern (Note 1)		15 kHz SCS: 3D1S1U, S=10D:2G:2U 30 kHz SCS: 7D1S2U, S=6D:4G:4U	60 kHz and 120 KHz SCS: 3D1S1U, S=10D:2G:2U
HARQ	Maximum number of HARQ transmissions	4	4
	RV sequence	0, 2, 3, 1	0, 2, 3, 1
DM-RS	DM-RS configuration type	1	1
	DM-RS duration	single-symbol DM-RS	single-symbol DM-RS
	Additional DM-RS position	pos1	pos1
	Number of DM-RS CDM group(s) without data	2	2
	Ratio of PUSCH EPRE to DM-RS EPRE	-3 dB	-3 dB
	DM-RS port	0	0
	DM-RS sequence generation	$N_{ID}^0=0, n_{SCID}=0$	$N_{ID}^0=0, n_{SCID}=0$
Time domain resource assignment	PUSCH mapping type	A, B	B
	Start symbol	0	0
	Allocation length	14	10
	Number of slots allocated for TBoMS PUSCH	4 for FDD 2 for TDD	2
	Number of repetitions of a single TBoMS	1	1
Frequency domain resource assignment	RB assignment	5 RBs in the middle of the test bandwidth	5RBs in the middle of the test bandwidth
	Frequency hopping	Disabled	Disabled
Code block group based PUSCH transmission		Disabled	Disabled
PT-RS configuration	Frequency density ( $K_{PT-RS}$ )	N.A.	Disabled
	Time density ( $L_{PT-RS}$ )	N.A.	Disabled
Note 1: The same requirements are applicable to TDD with different UL-DL pattern.			

- 6) The multipath fading emulators shall be configured according to the corresponding channel model defined in annex J.
- 7) Adjust the test signal mean power so the calibrated radiated SNR value at the BS receiver is as specified in clause 8.2.12.5.1 and clause 8.2.12.5.2 for *BS type 1-O* and *BS type 2-O* respectively, and that the SNR at the BS receiver is not impacted by the noise floor.

The power level for the transmission may be set such that the AWGN level at the RIB is equal to the AWGN level in table 8.2.12.4.2-2.

Table 8.2.12.4.2-2: AWGN power level at the BS input

BS type	Sub-carrier spacing (kHz)	Channel bandwidth (MHz)	AWGN power level
BS type 1-O (Note 4)	15	5	-86.5 - $\Delta_{OTAREFSENS}$ dBm / 4.5 MHz
	30	10	-83.6 - $\Delta_{OTAREFSENS}$ dBm / 8.64 MHz
BS type 2-O (Note 5)	60	50	$EIS_{REFSENS\_50M} + \Delta_{FR2\_REFSENS} + 15$ dBm / 47.52 MHz
	120	50	$EIS_{REFSENS\_50M} + \Delta_{FR2\_REFSENS} + 15$ dBm / 46.08 MHz

NOTE 1:  $\Delta_{OTAREFSENS}$  as declared in D.53 in table 4.6-1 and clause 7.1.  
NOTE 2:  $\Delta_{FR2\_REFSENS} = -3$  dB as described in clause 7.1, since the OTA REFSSENS reference direction (as declared in D.54 in table 4.6-1) is used for testing.  
NOTE 3:  $EIS_{REFSENS\_50M}$  as declared in D.28 in table 4.6-1.  
NOTE 4: The AWGN power level contains an AWGN offset of 16dB by default. If needed for test purposes, the AWGN level can be reduced from the default by any value in the range 0dB to 16dB. Changing the AWGN level does not impact the validity of the test, as it reduces the effective base band SNR level.  
NOTE 5: The AWGN power level contains an AWGN offset of 15dB by default. If needed for test purposes, the AWGN level can be reduced from the default by any value in the range 0dB to 15dB. Changing the AWGN level does not impact the validity of the test, as it reduces the effective base band SNR level.

8) For reference channels applicable to the BS, measure the throughput.

## 8.2.12.5 Test Requirement

### 8.2.12.5.1 Test requirement for BS type 1-O

The throughput measured according to clause 8.2.12.4.2 shall not be below the limits for the SNR levels specified in table 8.2.12.5.1-1 to 8.2.12.5.1-4.

**Table 8.2.12.5.1-1: Test requirements for PUSCH TBoMS, Type A, 5 MHz channel bandwidth, 15 kHz SCS**

Number of TX antennas	Number of RX antennas	Cyclic prefix	Duplex	Propagation conditions and correlation matrix (Annex J)	Fraction of maximum throughput	FRC (Annex A)	Additional DM-RS position	SNR (dB)
1	2	Normal	FDD	TDLB100-400 Low	70%	G-FR1-A3-36	pos1	-1.7
1	2	Normal	TDD	TDLB100-400 Low	70%	G-FR1-A3-35	pos1	-1.9

**Table 8.2.12.5.1-2: Test requirements for PUSCH TBoMS, Type A, 10 MHz channel bandwidth, 30 kHz SCS**

Number of TX antennas	Number of RX antennas	Cyclic prefix	Duplex	Propagation conditions and correlation matrix (Annex J)	Fraction of maximum throughput	FRC (Annex A)	Additional DM-RS position	SNR (dB)
1	2	Normal	FDD	TDLB100-400 Low	70%	G-FR1-A3-38	pos1	-1.8
1	2	Normal	TDD	TDLB100-400 Low	70%	G-FR1-A3-37	pos1	-1.9

**Table 8.2.12.5.1-3: Test requirements for PUSCH TBoMS, Type B, 5 MHz channel bandwidth, 15 kHz SCS**

Number of TX antennas	Number of RX antennas	Cyclic prefix	Duplex	Propagation conditions and correlation matrix (Annex J)	Fraction of maximum throughput	FRC (Annex A)	Additional DM-RS position	SNR (dB)
1	2	Normal	FDD	TDLB100-400 Low	70%	G-FR1-A3-36	pos1	-1.5
1	2	Normal	TDD	TDLB100-400 Low	70%	G-FR1-A3-35	pos1	-1.9

**Table 8.2.12.5.1-4: Test requirements for PUSCH TBoMS, Type B, 10 MHz channel bandwidth, 30 kHz SCS**

Number of TX antennas	Number of RX antennas	Cyclic prefix	Duplex	Propagation conditions and correlation matrix (Annex J)	Fraction of maximum throughput	FRC (Annex A)	Additional DM-RS position	SNR (dB)
1	2	Normal	FDD	TDLB100-400 Low	70%	G-FR1-A3-38	pos1	-1.8
1	2	Normal	TDD	TDLB100-400 Low	70%	G-FR1-A3-37	pos1	-1.9

NOTE: If the above Test Requirement differs from the Minimum Requirement then the Test Tolerance applied for this test is non-zero. The Test Tolerance for this test and the explanation of how the Minimum Requirement has been relaxed by the Test Tolerance is given in annex C.

### 8.2.12.5.2 Test requirement for *BS type 2-O*

The throughput measured according to clause 8.2.12.4.2 shall not be below the limits for the SNR levels specified in table 8.2.12.5.2-1 to 8.2.12.5.2-2.

**Table 8.2.12.5.2-1: Minimum requirements for PUSCH TBoMS, Type B, 50 MHz channel bandwidth, 60 kHz SCS**

Number of TX antennas	Number of RX antennas	Cyclic prefix	Duplex	Propagation conditions and correlation matrix (Annex J)	Fraction of maximum throughput	FRC (Annex A)	Additional DM-RS position	SNR (dB)
1	2	Normal	TDD	TDLA30-300 Low	70%	G-FR2-A3-27	pos1	-2.0

**Table 8.2.12.5.2-2: Minimum requirements for PUSCH TBoMS, Type B, 50 MHz channel bandwidth, 120 kHz SCS**

Number of TX antennas	Number of RX antennas	Cyclic prefix	Duplex	Propagation conditions and correlation matrix (Annex J)	Fraction of maximum throughput	FRC (Annex A)	Additional DM-RS position	SNR (dB)
1	2	Normal	TDD	TDLA30-300 Low	70%	G-FR2-A3-28	pos1	-1.8

## 8.2.13 Performance requirements for PUSCH with DMRS bundling

### 8.2.13.1 Definition and applicability

The performance requirement of PUSCH with DMRS bundling is determined by a minimum required throughput for a given SNR. The required throughput is expressed as a fraction of maximum throughput for the FRCs listed in annex A. The performance requirements assume HARQ re-transmissions.

Which specific test(s) are applicable to BS is based on the test applicability rules defined in clause 8.1.2.8.

### 8.2.13.2 Minimum Requirement

For *BS type 1-O*, the minimum requirement is in TS 38.104 [2], clause 11.2.1.13.

For *BS type 2-O*, the minimum requirement is in TS 38.104 [2], clause 11.2.2.10.

### 8.2.13.3 Test Purpose

The test shall verify the receiver's ability to achieve throughput under multipath fading propagation conditions for a given SNR with DMRS bundling.

### 8.2.13.4 Method of test

#### 8.2.13.4.1 Initial Conditions

Test environment: Normal, see annex B.2.

RF channels to be tested for single carrier:  $M$ ; see clause 4.9.1.

RF channels to be tested for carrier aggregation:  $M_{\text{BW Channel CA}}$ ; see clause 4.9.1.

Direction to be tested: OTA REFSENS *receiver target reference direction* (see D.54 in table 4.6-1).

#### 8.2.13.4.2 Procedure

- 1) Place the BS with its manufacturer declared coordinate system reference point in the same place as calibrated point in the test system, as shown in annex E.3.
- 2) Align the manufacturer declared coordinate system orientation of the BS with the test system.
- 3) Set the BS in the declared direction to be tested.
- 4) Connect the BS tester generating the wanted signal, multipath fading simulators and AWGN generators to a test antenna via a combining network in OTA test setup, as shown in annex E.3. Each of the demodulation branch signals should be transmitted on one polarization of the test antenna(s).
- 5) The characteristics of the wanted signal shall be configured according to the corresponding UL reference measurement channel defined in annex A, and according to additional test parameters listed in table 8.2.13.4.2-1.

Table 8.2.13.4.2-1: Test parameters for testing PUSCH with DMRS bundling

Parameter		BS type 1-O	BS type 2-O
Transform precoding		Disabled	
Example TDD UL-DL pattern (Note 1)		7D1S2U, S=6D:4G:4U	DDSUU, S=10D:2G:2U or DSUUU, S=10D:2G:2U
HARQ	Maximum number of HARQ transmissions	4	
	RV sequence (Note 2)	0, 3, 0, 3 for TDD 0, 0, 0, 0 for FDD	0, 3, 0, 3
DM-RS	DM-RS configuration type	1	
	DM-RS duration	single-symbol DM-RS	
	Additional DM-RS position	pos0, pos1	pos1
	Number of DM-RS CDM group(s) without data	2	
	Ratio of PUSCH EPRE to DM-RS EPRE	-3 dB	
	DM-RS port(s)	{0}	
	DM-RS sequence generation	$N_{ID}^0=0, n_{SCID}=0$	
Time domain resource assignment	PUSCH mapping type	A, B	B
	Start symbol	0	
	Allocation length	14	
	PUSCH aggregation factor	8 slots for FDD 2 slots for TDD	
Frequency domain resource assignment	RB assignment	Full applicable test bandwidth	
	Frequency hopping	Disabled	
Configured time domain window (cTDW) length		2 for TDD 8 for FDD	2
Code block group based PUSCH transmission		Disabled	Disabled
PTRS configuration	Frequency density ( $K_{PT-RS}$ )	N.A.	Disabled
	Time density ( $L_{PT-RS}$ )	N.A.	Disabled
Note 1: The same TDD requirements are applicable to different UL-DL patterns with more than one consecutive UL slots when both pusch-TimeDomainWindowLength and PUSCH aggregation factor are configured as 2 slots. The UL (re)transmission of PUSCH is only scheduled for the actual TDW including 2 consecutive UL slots.			
Note 2: The effective RV sequence is {0,2,3,1} with slot aggregation			

- 6) The multipath fading emulators shall be configured according to the corresponding channel model defined in annex J.
- 7) Adjust the test signal mean power so the calibrated radiated SNR value at the BS receiver is as specified in clause 8.2.13.5.1 and clause 8.2.13.5.2 for *BS type 1-O* and *BS type 2-O* respectively, and that the SNR at the BS receiver is not impacted by the noise floor.

The power level for the transmission may be set such that the AWGN level at the RIB is equal to the AWGN level in table 8.2.13.4.2-2.

Table 8.2.13.4.2-2: AWGN power level at the BS input

BS type	Sub-carrier spacing (kHz)	Channel bandwidth (MHz)	AWGN power level
BS type 1-O (Note 4)	15	5	-86.5 - $\Delta_{\text{OTAREFSSENS}}$ dBm / 4.5 MHz
	30	10	-83.6 - $\Delta_{\text{OTAREFSSENS}}$ dBm / 8.64 MHz
BS type 2-O (Note 5)	60	50	$\text{EIS}_{\text{REFSENS}_{50\text{M}}} + \Delta_{\text{FR2\_REFSENS}} + 15$ dBm / 47.52 MHz
	120	50	$\text{EIS}_{\text{REFSENS}_{50\text{M}}} + \Delta_{\text{FR2\_REFSENS}} + 15$ dBm / 46.08 MHz

NOTE 1:  $\Delta_{\text{OTAREFSSENS}}$  as declared in D.53 in table 4.6-1 and clause 7.1.  
NOTE 2:  $\Delta_{\text{FR2\_REFSENS}} = -3$  dB as described in clause 7.1, since the OTA REFSENS reference direction (as declared in D.54 in table 4.6-1) is used for testing.  
NOTE 3:  $\text{EIS}_{\text{REFSENS}_{50\text{M}}}$  as declared in D.28 in table 4.6-1.  
NOTE 4: The AWGN power level contains an AWGN offset of 16dB by default. If needed for test purposes, the AWGN level can be reduced from the default by any value in the range 0dB to 16dB. Changing the AWGN level does not impact the validity of the test, as it reduces the effective base band SNR level.  
NOTE 5: The AWGN power level contains an AWGN offset of 15dB by default. If needed for test purposes, the AWGN level can be reduced from the default by any value in the range 0dB to 15dB. Changing the AWGN level does not impact the validity of the test, as it reduces the effective base band SNR level.

8) For reference channels applicable to the BS, measure the throughput.

## 8.2.13.5 Test Requirement

### 8.2.13.5.1 Test requirement for BS type 1-O

The throughput measured according to clause 8.2.13.4.2 shall not be below the limits for the SNR levels specified in table 8.2.13.5.1-1 to table 8.2.13.5.1-8.

**Table 8.2.13.5.1-1: Test requirements for PUSCH with 70% of maximum throughput, Type A, 5 MHz channel bandwidth, FDD 15 kHz SCS**

Number of TX antennas	Number of demodulation branches	Cyclic prefix	Propagation conditions and correlation matrix (annex J)	Fraction of maximum throughput	FRC (annex A)	Additional DM-RS position	SNR (dB)
1	2	Normal	TDLA30-10 Low	70 %	G-FR1-A3B-7	pos0	-9.3
		Normal	TDLA30-10 Low	70 %	G-FR1-A3B-5	pos1	-7.3
	4	Normal	TDLA30-10 Low	70 %	G-FR1-A3B-7	pos0	-11.7
		Normal	TDLA30-10 Low	70 %	G-FR1-A3B-5	pos1	-11.2
	8	Normal	TDLA30-10 Low	70 %	G-FR1-A3B-7	pos0	-15.0
		Normal	TDLA30-10 Low	70 %	G-FR1-A3B-5	pos1	-14.4

**Table 8.2.13.5.1-2: Test requirements for PUSCH with 70% of maximum throughput, Type A, 5 MHz channel bandwidth, TDD 15 kHz SCS**

Number of TX antennas	Number of demodulation branches	Cyclic prefix	Propagation conditions and correlation matrix (annex J)	Fraction of maximum throughput	FRC (annex A)	Additional DM-RS position	SNR (dB)
1	2	Normal	TDLA30-10 Low	70 %	G-FR1-A3B-7	pos0	-3.0
		Normal	TDLA30-10 Low	70 %	G-FR1-A3B-5	pos1	-2.0
	4	Normal	TDLA30-10 Low	70 %	G-FR1-A3B-7	pos0	-6.2
		Normal	TDLA30-10 Low	70 %	G-FR1-A3B-5	pos1	-5.6
	8	Normal	TDLA30-10 Low	70 %	G-FR1-A3B-7	pos0	-10.0
		Normal	TDLA30-10 Low	70 %	G-FR1-A3B-5	pos1	-8.8

**Table 8.2.13.5.1-3: Test requirements for PUSCH with 70% of maximum throughput, Type A, 10 MHz channel bandwidth, FDD 30 kHz SCS**

Number of TX antennas	Number of demodulation branches	Cyclic prefix	Propagation conditions and correlation matrix (annex J)	Fraction of maximum throughput	FRC (annex A)	Additional DM-RS position	SNR (dB)
1	2	Normal	TDLA30-10 Low	70 %	G-FR1-A3B-8	pos0	-8.9
		Normal	TDLA30-10 Low	70 %	G-FR1-A3B-6	pos1	-9.2
	4	Normal	TDLA30-10 Low	70 %	G-FR1-A3B-8	pos0	-12.5
		Normal	TDLA30-10 Low	70 %	G-FR1-A3B-6	pos1	-12.4
	8	Normal	TDLA30-10 Low	70 %	G-FR1-A3B-8	pos0	-15.2
		Normal	TDLA30-10 Low	70 %	G-FR1-A3B-6	pos1	-14.7

**Table 8.2.13.5.1-4: Test requirements for PUSCH with 70% of maximum throughput, Type A, 10 MHz channel bandwidth, TDD 30 kHz SCS**

Number of TX antennas	Number of demodulation branches	Cyclic prefix	Propagation conditions and correlation matrix (annex J)	Fraction of maximum throughput	FRC (annex A)	Additional DM-RS position	SNR (dB)
1	2	Normal	TDLA30-10 Low	70 %	G-FR1-A3B-8	pos0	-3.2
		Normal	TDLA30-10 Low	70 %	G-FR1-A3B-6	pos1	-2.3
	4	Normal	TDLA30-10 Low	70 %	G-FR1-A3B-8	pos0	-6.4
		Normal	TDLA30-10 Low	70 %	G-FR1-A3B-6	pos1	-5.9
	8	Normal	TDLA30-10 Low	70 %	G-FR1-A3B-8	pos0	-9.7
		Normal	TDLA30-10 Low	70 %	G-FR1-A3B-6	pos1	-9.1

**Table 8.2.13.5.1-5: Test requirements for PUSCH with 70% of maximum throughput, Type B, 5 MHz channel bandwidth, FDD 15 kHz SCS**

Number of TX antennas	Number of demodulation branches	Cyclic prefix	Propagation conditions and correlation matrix (annex J)	Fraction of maximum throughput	FRC (annex A)	Additional DM-RS position	SNR (dB)
1	2	Normal	TDLA30-10 Low	70 %	G-FR1-A3B-7	pos0	-9.3
		Normal	TDLA30-10 Low	70 %	G-FR1-A3B-5	pos1	-7.7
	4	Normal	TDLA30-10 Low	70 %	G-FR1-A3B-7	pos0	-11.7
		Normal	TDLA30-10 Low	70 %	G-FR1-A3B-5	pos1	-11.2
	8	Normal	TDLA30-10 Low	70 %	G-FR1-A3B-7	pos0	-15.0
		Normal	TDLA30-10 Low	70 %	G-FR1-A3B-5	pos1	-14.4

**Table 8.2.13.5.1-6: Test requirements for PUSCH with 70% of maximum throughput, Type B, 5 MHz channel bandwidth, TDD 15 kHz SCS**

Number of TX antennas	Number of demodulation branches	Cyclic prefix	Propagation conditions and correlation matrix (annex J)	Fraction of maximum throughput	FRC (annex A)	Additional DM-RS position	SNR (dB)
1	2	Normal	TDLA30-10 Low	70 %	G-FR1-A3B-7	pos0	-2.8
		Normal	TDLA30-10 Low	70 %	G-FR1-A3B-5	pos1	-2.0
	4	Normal	TDLA30-10 Low	70 %	G-FR1-A3B-7	pos0	-6.2
		Normal	TDLA30-10 Low	70 %	G-FR1-A3B-5	pos1	-5.7
	8	Normal	TDLA30-10 Low	70 %	G-FR1-A3B-7	pos0	-10.0
		Normal	TDLA30-10 Low	70 %	G-FR1-A3B-5	pos1	-8.8



**Table 8.2.13.5.1-7: Test requirements for PUSCH with 70% of maximum throughput, Type B, 10 MHz channel bandwidth, FDD 30 kHz SCS**

Number of TX antennas	Number of demodulation branches	Cyclic prefix	Propagation conditions and correlation matrix (annex J)	Fraction of maximum throughput	FRC (annex A)	Additional DM-RS position	SNR (dB)
1	2	Normal	TDLA30-10 Low	70 %	G-FR1-A3B-8	pos0	-8.9
		Normal	TDLA30-10 Low	70 %	G-FR1-A3B-6	pos1	-9.2
	4	Normal	TDLA30-10 Low	70 %	G-FR1-A3B-8	pos0	-12.5
		Normal	TDLA30-10 Low	70 %	G-FR1-A3B-6	pos1	-12.7
	8	Normal	TDLA30-10 Low	70 %	G-FR1-A3B-8	pos0	-15.2
		Normal	TDLA30-10 Low	70 %	G-FR1-A3B-6	pos1	-14.9

**Table 8.2.13.5.1-8: Test requirements for PUSCH with 70% of maximum throughput, Type B, 10 MHz channel bandwidth, TDD 30 kHz SCS**

Number of TX antennas	Number of demodulation branches	Cyclic prefix	Propagation conditions and correlation matrix (annex J)	Fraction of maximum throughput	FRC (annex A)	Additional DM-RS position	SNR (dB)
1	2	Normal	TDLA30-10 Low	70 %	G-FR1-A3B-8	pos0	-2.7
		Normal	TDLA30-10 Low	70 %	G-FR1-A3B-6	pos1	-2.2
	4	Normal	TDLA30-10 Low	70 %	G-FR1-A3B-8	pos0	-6.4
		Normal	TDLA30-10 Low	70 %	G-FR1-A3B-6	pos1	-5.9
	8	Normal	TDLA30-10 Low	70 %	G-FR1-A3B-8	pos0	-9.7
		Normal	TDLA30-10 Low	70 %	G-FR1-A3B-6	pos1	-9.1

### 8.2.13.5.2 Test requirement for *BS type 2-0*

The throughput measured according to clause 8.2.13.4.2 shall not be below the limits for the SNR levels specified in table 8.2.13.5.2-1 and table 8.2.13.5.2-2.

**Table 8.2.13.5.2-1: Test requirements for PUSCH with 70% of maximum throughput, 50 MHz channel bandwidth, 60 kHz SCS**

Number of TX antennas	Number of demodulation branches	Cyclic prefix	Propagation conditions and correlation matrix (annex J)	Fraction of maximum throughput	FRC (annex A)	Additional DM-RS position	SNR (dB)
1	2	Normal	TDLA30-75 Low	70 %	G-FR2-A3B-1	pos1	-3.3

**Table 8.2.13.5.2-2: Test requirements for PUSCH with 70% of maximum throughput, 50 MHz channel bandwidth, 120 kHz SCS**

Number of TX antennas	Number of demodulation branches	Cyclic prefix	Propagation conditions and correlation matrix (annex J)	Fraction of maximum throughput	FRC (annex A)	Additional DM-RS position	SNR (dB)
1	2	Normal	TDLA30-75 Low	70 %	G-FR2-A3B-2	pos1	-2.9

## 8.2.14 Performance requirements for PUSCH for ATG

### 8.2.14.1 Definition and applicability

The performance requirement of PUSCH for ATG is determined by a minimum required throughput for a given SNR. The required throughput is expressed as a fraction of maximum throughput for the FRCs listed in annex A. The performance requirements assume HARQ re-transmissions. The performance requirements for 1Tx defined in 8.2.1, 8.2.2 and 8.2.3 are mandatory for a BS declaring support air-to-ground scenario.

Which specific test(s) are applicable to BS is based on the test applicability rules defined in clause 8.1.2.11.

### 8.2.14.2 Minimum Requirement

For *BS type I-O*, the minimum requirement is in TS 38.104 [2], clause 11.2.1.14.

### 8.2.14.3 Test Purpose

The test shall verify the receiver's ability to achieve throughput under air-to-ground conditions for a given SNR.

### 8.2.14.4 Method of test

#### 8.2.14.4.1 Initial conditions

Test environment: Normal, see annex B.2.

RF channels to be tested for single carrier: M, see clause 4.9.1.

RF channels to be tested for carrier aggregation:  $M_{\text{BW Channel CA}}$ ; see clause 4.9.1.

Direction to be tested: OTA REFSENS *receiver target reference direction* (see D.54 in table 4.6-1).

#### 8.2.14.4.2 Procedure

- 1) Place the BS with its manufacturer declared coordinate system reference point in the same place as calibrated point in the test system, as shown in annex E.3.
- 2) Align the manufacturer declared coordinate system orientation of the BS with the test system.
- 3) Set the BS in the declared direction to be tested.
- 4) Connect the BS tester generating the wanted signal, multipath fading simulators and AWGN generators to a test antenna via a combining network in OTA test setup, as shown in annex E.3. Each of the demodulation branch signals should be transmitted on one polarization of the test antenna(s).
- 5) The characteristics of the wanted signal shall be configured according to the corresponding UL reference measurement channel defined in annex A, and according to additional test parameters listed in table 8.2.14.4.2-1 for *BS type I-O*.

**Table: 8.2.14.4.2-1 Test parameters for testing PUSCH under ATG conditions (BS type 1-O)**

Parameter		FDD	TDD
Transform precoding		Disabled	
Default TDD UL-DL pattern (Note 1)			30 KHz SCS: 7D1S2U, S=6D:4G:4U
HARQ	Maximum number of HARQ transmissions	4	
	RV sequence	0, 2, 3, 1	
DM-RS	DM-RS configuration type	1	
	DM-RS duration	single-symbol DM-RS	
	Additional DM-RS position	pos1	
	Number of DM-RS CDM group(s) without data	2	
	Ratio of PUSCH EPRE to DM-RS EPRE	-3 dB	
	DM-RS port(s)	{0}	
	DM-RS sequence generation	$N_{ID}^0=0, n_{SCID}=0$	
Time domain resource assignment	PUSCH mapping type	A	
	Start symbol	0	
	Allocation length	14	
Frequency domain resource assignment	RB assignment	Full applicable test bandwidth	
	Frequency hopping	Disabled	
Code block group based PUSCH transmission		Disabled	
NOTE 1: The same requirements are applicable to TDD with different UL-DL pattern, e.g., 30D4S6U, S=14G for 30kHz SCS.			

- 6) The multipath fading emulators shall be configured according to the corresponding channel model defined in annex J.
- 7) Adjust the test signal mean power so the calibrated radiated SNR value at the BS receiver is as specified in clause 8.2.14.5.1, and that the SNR at the BS receiver is not impacted by the noise floor.

The power level for the transmission may be set such that the AWGN level at the RIB is equal to the AWGN level in table 8.2.14.4.2-2.

**Table 8.2.14.4.2-2: AWGN power level at the BS input**

BS type	Sub-carrier spacing (kHz)	Channel bandwidth (MHz)	AWGN power level
BS type 1-O (Note 2)	15	5	-86.5 - $\Delta_{OTAREFSENS}$ dBm / 4.5 MHz
	30	10	-83.6 - $\Delta_{OTAREFSENS}$ dBm / 8.64 MHz
NOTE 1: $\Delta_{OTAREFSENS}$ as declared in D.53 in table 4.6-1 and clause 7.1.			
NOTE 2: The AWGN power level contains an AWGN offset of 16dB by default. If needed for test purposes, the AWGN level can be reduced from the default by any value in the range 0dB to 16dB. Changing the AWGN level does not impact the validity of the test, as it reduces the effective base band SNR level.			

- 8) For reference channels applicable to the BS, measure the BLER. BLER is evaluated based on the test methodology described in Annex I.

## 8.2.14.5 Test requirement

### 8.2.14.5.1 Test requirement for BS type 1-O

The throughput measured according to clause 8.2.14.4.2 shall not be below the limits for the SNR levels specified in table 8.2.14.5.1-1 to table 8.2.14.5.1-2 for 1Tx spatial multiplexing transmission.

**Table 8.2.14.5.1-1: Test requirements for PUSCH with 70% of maximum throughput, Type A, 5 MHz channel bandwidth, 15 kHz SCS**

Number of TX antennas	Number of demodulation branches	Cyclic prefix	Propagation conditions and correlation matrix(Annex J)	Frequency offset	Fraction of maximum throughput	FRC (annex A)	Additional DM-RS position	SNR (dB)
1	2	Normal	AWGN	200Hz	70%	G-FR1-A13-1	pos1	9.7
			AWGN	200Hz	70%	G-FR1-A14-1	pos1	20.0

**Table 8.2.14.5.1-2: Test requirements for PUSCH with 70% of maximum throughput, Type A, 10 MHz channel bandwidth, 30 kHz SCS**

Number of TX antennas	Number of demodulation branches	Cyclic prefix	Propagation conditions and correlation matrix (Annex J)	Frequency offset	Fraction of maximum throughput	FRC (annex A)	Additional DM-RS position	SNR (dB)
1	2	Normal	AWGN	500Hz	70%	G-FR1-A13-2	pos1	9.3
			AWGN	500Hz	70%	G-FR1-A14-2	pos1	20.3

## 8.2.15 Performance requirements for PUSCH with enhanced DM-RS

### 8.2.15.1 Definition and applicability

The performance requirement of PUSCH with enhanced DM-RS is determined by a minimum required throughput for a given SNR. The required throughput is expressed as a fraction of maximum throughput for the FRCs listed in annex A. The performance requirements assume HARQ re-transmissions.

Which specific test(s) are applicable to BS is based on the test applicability rules defined in clause 8.1.2.1.11.

### 8.2.15.2 Minimum Requirement

For *BS type I-O*, the minimum requirement is in TS 38.104 [2], clause 11.2.1.15.

### 8.2.15.3 Test purpose

The test shall verify the receiver's ability to achieve throughput under multipath fading propagation conditions for a given SNR.

### 8.2.15.4 Method of test

#### 8.2.15.4.1 Initial conditions

Test environment: Normal, see annex B.2.

RF channels to be tested for single carrier: M, see clause 4.9.1.

RF channels to be tested for carrier aggregation:  $M_{\text{BW Channel CA}}$ ; see clause 4.9.1.

Direction to be tested: OTA REFSENS *receiver target reference direction* (see D.54 in table 4.6-1).

#### 8.2.15.4.2 Procedure

- 1) Place the BS with its manufacturer declared coordinate system reference point in the same place as calibrated point in the test system, as shown in annex E.3.
- 2) Align the manufacturer declared coordinate system orientation of the BS with the test system.
- 3) Set the BS in the declared direction to be tested.
- 4) Connect the BS tester generating the wanted signal, multipath fading simulators and AWGN generators to a test antenna via a combining network in OTA test setup, as shown in annex E.3. Each of the demodulation branch signals should be transmitted on one polarization of the test antenna(s).
- 5) The characteristics of the wanted signal shall be configured according to the corresponding UL reference measurement channel defined in annex A, and according to additional test parameters listed in table 8.2.15.4.2-1.

**Table 8.2.15.4.2-1: Test parameters for testing PUSCH with enhanced DM-RS**

Parameter		BS type 1-O
Transform precoding		Disabled
Default TDD UL-DL pattern (Note 1)		15 kHz SCS: 3D1S1U, S=10D:2G:2U 30 kHz SCS: 7D1S2U, S=6D:4G:4U
HARQ	Maximum number of HARQ transmissions	4
	RV sequence	0, 2, 3, 1
DM-RS	DM-RS configuration type	enhanced DM-RS type 1
	DM-RS duration	single-symbol DM-RS
	Additional DM-RS position	pos1
	Number of DM-RS CDM group(s) without data	2
	Ratio of PUSCH EPRE to DM-RS EPRE	-3 dB
	DM-RS port(s)	{8}, {8,9}
	DM-RS sequence generation	$N_{ID}^0=0$ , $n_{SCID}=0$
Time domain resource assignment	PUSCH mapping type	A, B
	Start symbol	0
	Allocation length	14
Frequency domain resource assignment	RB assignment	Full applicable test bandwidth
	Frequency hopping	Disabled
TPMI index for 2Tx two layer spatial multiplexing transmission		0
Code block group based PUSCH transmission		Disabled
PTRS configuration	Frequency density ( $K_{PT-RS}$ )	N.A.
	Time density ( $L_{PT-RS}$ )	N.A.
Note 1: The same requirements are applicable to FDD and TDD with different UL-DL patterns for BS type 1-O.		

- 6) The multipath fading emulators shall be configured according to the corresponding channel model defined in annex J.
- 7) Adjust the test signal mean power so the calibrated radiated SNR value at the BS receiver is as specified in clause 8.2.15.5.1 for *BS type 1-O*, and that the SNR at the BS receiver is not impacted by the noise floor.

The power level for the transmission may be set such that the AWGN level at the RIB is equal to the AWGN level in table 8.2.15.4.2-2.

Table 8.2.15.4.2-2: AWGN power level at the BS input

BS type	Sub-carrier spacing (kHz)	Channel bandwidth (MHz)	AWGN power level
BS type 1-O (Note 2)	15	5	-86.5 - $\Delta_{OTAREFSENS}$ dBm / 4.5 MHz
	30	10	-83.6 - $\Delta_{OTAREFSENS}$ dBm / 8.64 MHz
NOTE 1: $\Delta_{OTAREFSENS}$ as declared in D.53 in table 4.6-1 and clause 7.1.			
NOTE 2: The AWGN power level contains an AWGN offset of 16dB by default. If needed for test purposes, the AWGN level can be reduced from the default by any value in the range 0dB to 16dB. Changing the AWGN level does not impact the validity of the test, as it reduces the effective base band SNR level.			

8) For reference channels applicable to the BS, measure the throughput.

## 8.2.15.5 Test Requirement

### 8.2.15.5.1 Test requirement for BS type 1-O

The throughput measured according to clause 8.2.15.4.2 shall not be below the limits for the SNR levels specified in table 8.2.15.5.1-1 to table 8.2.15.5.1-4 for 1Tx and for 2Tx two layer spatial multiplexing transmission.

**Table 8.2.15.5.1-1: Test requirements for PUSCH with 70% of maximum throughput, Type A, 5 MHz channel bandwidth, 15 kHz SCS**

Number of TX antennas	Number of demodulation branches	Cyclic prefix	Propagation conditions and correlation matrix (annex J)	Fraction of maximum throughput	FRC (annex A)	Additional DM-RS position	SNR (dB)
1	2	Normal	TDLC300-100 Low	70 %	G-FR1-A4-8	pos1	10.7
2	2	Normal	TDLC300-100 Low	70 %	G-FR1-A4-22	pos1	19.0

**Table 8.2.15.5.1-2: Test requirements for PUSCH with 70% of maximum throughput, Type A, 10 MHz channel bandwidth, 30 kHz SCS**

Number of TX antennas	Number of demodulation branches	Cyclic prefix	Propagation conditions and correlation matrix (annex J)	Fraction of maximum throughput	FRC (annex A)	Additional DM-RS position	SNR (dB)
1	2	Normal	TDLC300-100 Low	70 %	G-FR1-A4-11	pos1	10.8
2	2	Normal	TDLC300-100 Low	70 %	G-FR1-A4-25	pos1	19.2

**Table 8.2.15.5.1-3: Test requirements for PUSCH with 70% of maximum throughput, Type B, 5 MHz channel bandwidth, 15 kHz SCS**

Number of TX antennas	Number of demodulation branches	Cyclic prefix	Propagation conditions and correlation matrix (annex J)	Fraction of maximum throughput	FRC (annex A)	Additional DM-RS position	SNR (dB)
1	2	Normal	TDLC300-100 Low	70 %	G-FR1-A4-8	pos1	10.8
2	2	Normal	TDLC300-100 Low	70 %	G-FR1-A4-22	pos1	19.1

**Table 8.2.15.5.1-4: Test requirements for PUSCH with 70% of maximum throughput, Type B, 10 MHz channel bandwidth, 30 kHz SCS**

Number of TX antennas	Number of demodulation branches	Cyclic prefix	Propagation conditions and correlation matrix (annex J)	Fraction of maximum throughput	FRC (annex A)	Additional DM-RS position	SNR (dB)
1	2	Normal	TDLC300-100 Low	70 %	G-FR1-A4-11	pos1	10.7
2	2	Normal	TDLC300-100 Low	70 %	G-FR1-A4-25	pos1	19.3

NOTE: If the above Test Requirement differs from the Minimum Requirement then the Test Tolerance applied for this test is non-zero. The Test Tolerance for this test and the explanation of how the Minimum Requirement has been relaxed by the Test Tolerance is given in annex C.

## 8.3 OTA performance requirements for PUCCH

### 8.3.1 Performance requirements for PUCCH format 0

#### 8.3.1.1 Definition and applicability

The performance requirement of single user PUCCH format 0 for ACK missed detection is determined by the two parameters: probability of false detection of the ACK and the probability of detection of ACK. The performance is measured by the required SNR at probability of detection equal to 0.99. The probability of false detection of the ACK shall be 0.01 or less.

The probability of false detection of the ACK is defined as a conditional probability of erroneous detection of the ACK when input is only noise.

The probability of detection of ACK is defined as conditional probability of detection of the ACK when the signal is present.

The transient period as specified in TS 38.101-1 [24] clause 6.3.3.1 and TS 38.101-2 [25] clause 6.3.3.1 is not taken into account for performance requirement testing, where the RB hopping is symmetric to the CC center, i.e. intra-slot frequency hopping is enabled.

Which specific test(s) are applicable to BS is based on the test applicability rules defined in clause 8.1.2.

#### 8.3.1.2 Minimum Requirement

For *BS type 1-O*, the minimum requirements are in TS 38.104 [2] clause 11.3.1.1 and 11.3.1.2.

For *BS type 2-O*, the minimum requirements are in TS 38.104 [2] clause 11.3.2.1 and 11.3.2.2.

#### 8.3.1.3 Test purpose

The test shall verify the receiver's ability to detect ACK under multipath fading propagation conditions for a given SNR.

#### 8.3.1.4 Method of test

##### 8.3.1.4.1 Initial conditions

Test environment: Normal, see annex B.2.

RF channels to be tested: single carrier *M*; see clause 4.9.1.

Direction to be tested: OTA REFSENS receiver target reference direction (see D.54 in table 4.6-1).

#### 8.3.1.4.2 Procedure

- 1) Place the BS with its manufacturer declared coordinate system reference point in the same place as calibrated point in the test system, as shown in annex E.3.
- 2) Align the manufacturer declared coordinate system orientation of the BS with the test system.
- 3) Set the BS in the declared direction to be tested.
- 4) Connect the BS tester generating the wanted signal, multipath fading simulators and AWGN generators to a test antenna via a combining network in OTA test setup, as shown in annex E.3. Each of the demodulation branch signals should be transmitted on one polarization of the test antenna(s).
- 5) The characteristics of the wanted signal shall be configured according to TS 38.211 [20] and according to additional test parameters listed in table 8.3.1.4.2-1.

**Table 8.3.1.4.2-1: Test parameters**

Parameter	BS type 1-O	BS type 2-O
number of UCI information bits	1	1
Number of PRBs	1	FR2-1: 1 FR2-2: 1, 16
First PRB prior to frequency hopping	0	0
Intra-slot frequency hopping	N/A for 1 symbol Enabled for 2 symbols	N/A for 1 symbol Enabled for 2 symbols
First PRB after frequency hopping	The largest PRB index – (number of PRBs – 1)	The largest PRB index – (number of PRBs – 1)
Group and sequence hopping	neither	neither
Hopping ID	0	0
Initial cyclic shift	0	0
First symbol	13 for 1 symbol 12 for 2 symbols	13 for 1 symbol 12 for 2 symbols

- 6) The multipath fading emulators shall be configured according to the corresponding channel model defined in annex J.2.
- 7) Adjust the test signal mean power so the calibrated radiated SNR value at the BS receiver is as specified in clause 8.3.1.5.1 and 8.3.1.5.2 for *BS type 1-O* and *BS type 2-O* respectively, and that the SNR at the BS receiver is not impacted by the noise floor.

The power level for the transmission may be set such that the AWGN level at the RIB is equal to the AWGN level quoted in table 8.3.1.4.2-2.



Table 8.3.1.4.2-2: AWGN power level at the BS input

Table 8.3.1.4.2-2: AWGN power level at the BS input

BS type	Sub-carrier spacing (kHz)	Channel bandwidth (MHz)	AWGN power level
BS type 1-O (Note 4)	15	5	-83.5 - $\Delta_{OTAREFSENS}$ dBm / 4.5 MHz
		10	-80.3 - $\Delta_{OTAREFSENS}$ dBm / 9.36 MHz
		20	-77.2 - $\Delta_{OTAREFSENS}$ dBm / 19.08 MHz
	30	10	-80.6 - $\Delta_{OTAREFSENS}$ dBm / 8.64 MHz
		20	-77.4 - $\Delta_{OTAREFSENS}$ dBm / 18.36 MHz
		40	-74.2 - $\Delta_{OTAREFSENS}$ dBm / 38.16 MHz
		100	-70.1 - $\Delta_{OTAREFSENS}$ dBm / 98.28 MHz
BS type 2-O (Note 5)	60	50	$EIS_{REFSENS\_50M} + \Delta_{FR2\_REFSENS} + 15$ dBm / 47.52 MHz
		100	$EIS_{REFSENS\_50M} + \Delta_{FR2\_REFSENS} + 18$ dBm / 95.04 MHz
	120	50	$EIS_{REFSENS\_50M} + \Delta_{FR2\_REFSENS} + 15$ dBm / 46.08 MHz
		100	$EIS_{REFSENS\_50M} + \Delta_{FR2\_REFSENS} + 18$ dBm / 95.04 MHz
		200	$EIS_{REFSENS\_50M} + \Delta_{FR2\_REFSENS} + 21$ dBm / 190.08 MHz
	480	400	$EIS_{REFSENS\_50M} + \Delta_{FR2\_REFSENS} + 24$ dBm / 380.16 MHz
		400	$EIS_{REFSENS\_50M} + \Delta_{FR2\_REFSENS} + 24$ dBm / 380.16 MHz

NOTE 1:  $\Delta_{OTAREFSENS}$  as declared in D.53 in table 4.6-1 and clause 7.1.  
 NOTE 2:  $\Delta_{FR2\_REFSENS} = -3$  dB as described in clause 7.1 since the OTA REFSSENS reference direction (as declared in D.54 in table 4.6-1) is used for testing.  
 NOTE 3:  $EIS_{REFSENS\_50M}$  as declared in D.28 in table 4.6-1.  
 NOTE 4: The AWGN power level contains an AWGN offset of 16dB by default. If needed for test purposes, the AWGN level can be reduced from the default by any value in the range 0dB to 16dB. Changing the AWGN level does not impact the validity of the test, as it reduces the effective base band SNR level.  
 NOTE 5: The AWGN power level contains an AWGN offset of 15dB by default. If needed for test purposes, the AWGN level can be reduced from the default by any value in the range 0dB to 15dB. Changing the AWGN level does not impact the validity of the test, as it reduces the effective base band SNR level.

8) The signal generator sends a test pattern with the pattern outlined in figure 8.3.1.4.2-1. The following statistics are kept: the number of ACKs detected in the idle periods and the number of missed ACKs.



Figure 8.3.1.4.2-1: Test signal pattern for single user PUCCH format 0 demodulation tests

8.3.1.5 Test Requirement

8.3.1.5.1 Test requirement for BS type 1-O

The fraction of falsely detected ACKs shall be less than 1% and the fraction of correctly detected ACKs shall be larger than 99% for the SNR listed in table 8.3.1.5.1-1 and in table 8.3.1.5.1-2.

Table 8.3.1.5.1-1: Test requirements for PUCCH format 0 and 15 kHz SCS

Number of TX antennas	Number of demodulation branches	Propagation conditions and correlation matrix (annex J)	Number of OFDM symbols	Channel bandwidth / SNR (dB)		
				5 MHz	10 MHz	20 MHz
1	2	TDLC300-100 Low	1	10.0	9.4	9.9
			2	3.4	4.3	3.9

Table 8.3.1.5.1-2: Test requirements for PUCCH format 0 and 30 kHz SCS

Number of TX antennas	Number of demodulation branches	Propagation conditions and correlation matrix (annex J)	Number of OFDM symbols	Channel bandwidth / SNR (dB)			
				10 MHz	20 MHz	40 MHz	100 MHz
1	2	TDLC300-100 Low	1	10.4	10.4	10.1	9.8
			2	4.8	4.2	4.4	4.1

### 8.3.1.5.2 Test requirement for *BS type 2-0*

The fraction of falsely detected ACKs shall be less than 1% and the fraction of correctly detected ACKs shall be larger than 99% for the SNR listed in table 8.3.1.5.2-1 to table 8.3.1.5.2-4.

Table 8.3.1.5.2-1: Test requirements for PUCCH format 0 and 60 kHz SCS in FR2-1

Number of TX antennas	Number of demodulation branches	Propagation conditions and correlation matrix (annex J)	Number of OFDM symbols	Channel bandwidth / SNR (dB)	
				50 MHz	100 MHz
1	2	TDLA30-300 Low	1	9.9	9.6
			2	4.8	4.6

Table 8.3.1.5.2-2: Test requirements for PUCCH format 0 and 120 kHz SCS in FR2-1

Number of TX antennas	Number of demodulation branches	Propagation conditions and correlation matrix (annex J)	Number of OFDM symbols	Channel bandwidth / SNR (dB)		
				50 MHz	100 MHz	200 MHz
1	2	TDLA30-300 Low	1	10.1	9.8	10.3
			2	4.7	4.4	4.6

Table 8.3.1.5.2-3: Test requirements for PUCCH format 0 and 120 kHz SCS in FR2-2

Number of TX antennas	Number of demodulation branches	Propagation conditions and correlation matrix (annex J)	Number of OFDM symbols	Number of PRB	Channel bandwidth / SNR (dB)
					100 MHz
1	2	TDLA30-650 Low	1	1	10.2
			2	16	-5.2

Table 8.3.1.5.2-4: Test requirements for PUCCH format 0 and 480 kHz SCS in FR2-2

Number of TX antennas	Number of demodulation branches	Propagation conditions and correlation matrix (annex J)	Number of OFDM symbols	Number of PRB	Channel bandwidth / SNR (dB)
					400 MHz
1	2	TDLA10-650 Low	1	1	10.3
			2	16	-4.0

## 8.3.2 Performance requirements for PUCCH format 1

### 8.3.2.1 NACK to ACK detection

#### 8.3.2.1.1 Definition and applicability

The performance requirement of PUCCH format 1 for NACK to ACK detection is determined by the two parameters: probability of false detection of the ACK and the NACK to ACK detection probability. The performance is measured by the required SNR at probability of the NACK to ACK detection equal to 0.1% or less. The probability of false detection of the ACK shall be 0.01 or less.

The probability of false detection of the ACK is defined as a conditional probability of erroneous detection of the ACK at particular bit position when input is only noise. Each false bit detection is counted as one error.

The NACK to ACK detection probability is the probability of detecting an ACK bit when an NACK bit was sent on particular bit position. Each NACK bit erroneously detected as ACK bit is counted as one error. Erroneously detected NACK bits in the definition do not contain the NACK bits which are mapped from DTX, i.e. NACK bits received when DTX is sent should not be considered.

The transient period as specified in TS 38.101-1 [24] and TS 38.101-2 [25] clause 6.3.3.1 is not taken into account for performance requirement testing, where the RB hopping is symmetric to the CC center, i.e. intra-slot frequency hopping is enabled.

Which specific test(s) are applicable to BS is based on the test applicability rules defined in clause 8.1.2.

### 8.3.2.1.2 Minimum Requirement

For BS type 1-O, the minimum requirement is in TS 38.104 [2], clause 11.3.1.3.

For BS type 2-O, the minimum requirement is in TS 38.104 [2], clause 11.3.2.3.

### 8.3.2.1.3 Test purpose

The test shall verify the receiver's ability not to falsely detect NACK bits as ACK bits under multipath fading propagation conditions for a given SNR.

### 8.3.2.1.4 Method of test

#### 8.3.2.1.4.1 Initial Conditions

Test environment: Normal; see annex B.2.

RF channels to be tested for single carrier: M; see clause 4.9.1

Direction to be tested: OTA REFSENS receiver target reference direction (see D.54 in table 4.6-1).

#### 8.3.2.1.4.2 Procedure

- 1) Place the BS with its manufacturer declared coordinate system reference point in the same place as calibrated point in the test system, as shown in annex E.3.
- 2) Align the manufacturer declared coordinate system orientation of the BS with the test system.
- 3) Set the BS in the declared direction to be tested.
- 4) Connect the BS tester generating the wanted signal, multipath fading simulators and AWGN generators to a test antenna via a combining network in OTA test setup, as shown in annex E.3. Each of the demodulation branch signals should be transmitted on one polarization of the test antenna(s).
- 5) The characteristics of the wanted signal shall be configured according to TS 38.211 [20], and according to additional test parameters listed in table 8.3.2.1.4.2-1.

**Table 8.3.2.1.4.2-1: Test parameters**

Parameter	Test
Number of information bits	2
Number of PRBs	FR1 and FR2-1: 1 FR2-2: 1, 16
Number of symbols	14
First PRB prior to frequency hopping	0
Intra-slot frequency hopping	enabled
First PRB after frequency hopping	The largest PRB index - ( $n_{rofPRBs} - 1$ )
Group and sequence hopping	neither
Hopping ID	0
Initial cyclic shift	0
First symbol	0
Index of orthogonal cover code ( <i>timeDomainOCC</i> )	0

- 6) The multipath fading emulators shall be configured according to the corresponding channel model defined in annex J.
- 7) Adjust the test signal mean power so the calibrated radiated SNR value at the BS receiver is as specified in clause 8.3.2.1.5.1 and 8.3.2.1.5.2 for BS type 1-O and BS type 2-O respectively, and that the SNR at the BS receiver is not impacted by the noise floor.

The power level for the transmission may be set such that the AWGN level at the RIB is equal to the AWGN level in table 8.3.2.1.4.2-2.

Table 8.3.2.1.4.2-2: AWGN power level at the BS input

BS type	Subcarrier spacing (kHz)	Channel bandwidth (MHz)	AWGN power level
BS type 1-O (Note 4)	15 kHz	5	-83.5 - $\Delta_{OTAREFSENS}$ dBm / 4.5 MHz
		10	-80.3 - $\Delta_{OTAREFSENS}$ dBm / 9.36 MHz
		20	-77.2 - $\Delta_{OTAREFSENS}$ dBm / 19.08 MHz
	30 kHz	10	-80.6 - $\Delta_{OTAREFSENS}$ dBm / 8.64 MHz
		20	-77.4 - $\Delta_{OTAREFSENS}$ dBm / 18.36 MHz
		40	-74.2 - $\Delta_{OTAREFSENS}$ dBm / 38.16 MHz
BS type 2-O (Note 5)	60 kHz	50	EIS <sub>REFSENS_50M</sub> + $\Delta_{FR2\_REFSENS}$ + 15 dBm / 47.52 MHz
		100	EIS <sub>REFSENS_50M</sub> + $\Delta_{FR2\_REFSENS}$ + 18 dBm / 95.04 MHz
	120 kHz	50	EIS <sub>REFSENS_50M</sub> + $\Delta_{FR2\_REFSENS}$ + 15 dBm / 46.08 MHz
		100	EIS <sub>REFSENS_50M</sub> + $\Delta_{FR2\_REFSENS}$ + 18 dBm / 95.04 MHz
		200	EIS <sub>REFSENS_50M</sub> + $\Delta_{FR2\_REFSENS}$ + 21 dBm / 190.08 MHz
	480 kHz	400	EIS <sub>REFSENS_50M</sub> + $\Delta_{FR2\_REFSENS}$ + 24 dBm / 380.16 MHz
		400	EIS <sub>REFSENS_50M</sub> + $\Delta_{FR2\_REFSENS}$ + 24 dBm / 380.16 MHz
NOTE 1: $\Delta_{OTAREFSENS}$ as declared in D.53 in table 4.6-1 and clause 7.1.			
NOTE 2: $\Delta_{FR2\_REFSENS}$ = -3 dB as described in clause 7.1, since the OTA REFSSENS reference direction (as declared in D.54 in table 4.6-1) is used for testing.			
NOTE 3: EIS <sub>REFSENS_50M</sub> as declared in D.28 in table 4.6-1.			
NOTE 4: The AWGN power level contains an AWGN offset of 16dB by default. If needed for test purposes, the AWGN level can be reduced from the default by any value in the range 0dB to 16dB. Changing the AWGN level does not impact the validity of the test, as it reduces the effective base band SNR level.			
NOTE 5: The AWGN power level contains an AWGN offset of 15dB by default. If needed for test purposes, the AWGN level can be reduced from the default by any value in the range 0dB to 15dB. Changing the AWGN level does not impact the validity of the test, as it reduces the effective base band SNR level.			

- 8) The signal generator sends random codeword from applicable codebook, in regular time periods. The following statistics are kept: the number of ACK bits detected in the idle periods and the number of NACK bits detected as ACK.

### 8.3.2.1.5 Test Requirement

#### 8.3.2.1.5.1 Test Requirement for BS type 1-0

The fraction of falsely detected ACK bits shall be less than 1 % and the fraction of NACK bits falsely detected as ACK shall be less than 0.1 % for the SNR listed in tables 8.3.2.1.5.1-1 and table 8.3.2.1.5.1-2.

Table 8.3.2.1.5.1-1: Required SNR for PUCCH format 1 with 15 kHz SCS

Number of TX antennas	Number of Demodulation Branches	Cyclic Prefix	Propagation conditions and correlation matrix (annex J)	Channel bandwidth / SNR (dB)		
				5 MHz	10 MHz	20 MHz
1	2	Normal	TDLC300-100 Low	-3.2	-3.0	-3.0

**Table 8.3.2.1.5.1-2: Required SNR for PUCCH format 1 with 30 kHz SCS**

Number of TX antennas	Number of Demodulation Branches	Cyclic Prefix	Propagation conditions and correlation matrix (annex J)	Channel bandwidth / SNR (dB)			
				10 MHz	20 MHz	40 MHz	100 MHz
1	2	Normal	TDLC300-100 Low	-2.2	-2.7	-3.3	-2.9

### 8.3.2.1.5.2 Test Requirement for BS type 2-O

The fraction of falsely detected ACK bits shall be less than 1 % and the fraction of NACK bits falsely detected as ACK shall be less than 0.1 % for the SNR listed in tables 8.3.2.1.5.2-1 to table 8.3.2.1.5.2-4.

**Table 8.3.2.1.5.2-1: Required SNR for PUCCH format 1 with 60 kHz SCS in FR2-1**

Number of TX antennas	Number of Demodulation Branches	Cyclic Prefix	Propagation conditions and correlation matrix (annex J)	Channel bandwidth / SNR (dB)	
				50 MHz	100 MHz
1	2	Normal	TDLA30-300 Low	-0.6	-3.6

**Table 8.3.2.1.5.2-2: Required SNR for PUCCH format 1 with 120 kHz SCS in FR2-1**

Number of TX antennas	Number of Demodulation Branches	Cyclic Prefix	Propagation conditions and correlation matrix (annex J)	Channel bandwidth / SNR (dB)		
				50 MHz	100 MHz	200 MHz
1	2	Normal	TDLA30-300 Low	-3.3	-3.3	-2.4

**Table 8.3.2.1.5.2-3: Required SNR for PUCCH format 1 and 120 kHz SCS in FR2-2**

Number of TX antennas	Number of demodulation branches	Cyclic Prefix	Propagation conditions and correlation matrix (annex J)	Number of PRB	Channel bandwidth / SNR (dB)
					100 MHz
1	2	Normal	TDLA30-650 Low	1	-3.5
				16	-14.2

**Table 8.3.2.1.5.2-4: Required SNR for PUCCH format 1 and 480 kHz SCS in FR2-2**

Number of TX antennas	Number of demodulation branches	Cyclic Prefix	Propagation conditions and correlation matrix (annex J)	Number of PRB	Channel bandwidth / SNR (dB)
					400 MHz
1	2	Normal	TDLA10-650 Low	1	-3.6
				16	-13.8

## 8.3.2.2 ACK missed detection

### 8.3.2.2.1 Definition and applicability

The performance requirement of PUCCH format 1 for ACK missed detection is determined by the two parameters: probability of false detection of the ACK and the probability of detection of ACK. The performance is measured by the required SNR at probability of detection equal to 0.99. The probability of false detection of the ACK shall be 0.01 or less.

The probability of false detection of the ACK is defined as a conditional probability of erroneous detection of the ACK when input is only noise.

The probability of detection of ACK is defined as conditional probability of detection of the ACK when the signal is present.

The transient period as specified in TS 38.101-1 [24] and TS 38.101-2 [25] clause 6.3.3.1 is not taken into account for performance requirement testing, where the RB hopping is symmetric to the CC center, i.e. intra-slot frequency hopping is enabled.

Which specific test(s) are applicable to BS is based on the test applicability rules defined in clause 8.1.2.

### 8.3.2.2.2 Minimum Requirement

For BS type 1-O, the minimum requirement is in TS 38.104 [2], clause 11.3.1.3.

For BS type 2-O, the minimum requirement is in TS 38.104 [2], clause 11.3.2.3.

### 8.3.2.2.3 Test purpose

The test shall verify the receiver's ability to detect ACK bits under multipath fading propagation conditions for a given SNR.

### 8.3.2.2.4 Method of test

#### 8.3.2.2.4.1 Initial Conditions

Test environment: Normal; see annex B.2.

RF channels to be tested for single carrier: M; see clause 4.9.1

Direction to be tested: OTA REFSENS receiver target reference direction (see D.54 in table 4.6-1).

#### 8.3.2.2.4.2 Procedure

- 1) Place the BS with its manufacturer declared coordinate system reference point in the same place as calibrated point in the test system, as shown in annex E.3.
- 2) Align the manufacturer declared coordinate system orientation of the BS with the test system.
- 3) Set the BS in the declared direction to be tested.
- 4) Connect the BS tester generating the wanted signal, multipath fading simulators and AWGN generators to a test antenna via a combining network in OTA test setup, as shown in annex E.3. Each of the demodulation branch signals should be transmitted on one polarization of the test antenna(s).
- 5) The characteristics of the wanted signal shall be configured according to TS 38.211 [20], and according to additional test parameters listed in table 8.3.2.2.4.2-1.

**Table 8.3.2.2.4.2-1: Test Parameters**

Parameter	Value
Number of information bits	2
Number of PRBs	FR1 and FR2-1: 1 FR2-2: 1, 16
Number of symbols	14
First PRB prior to frequency hopping	0
Intra-slot frequency hopping	enabled
First PRB after frequency hopping	The largest PRB index – (nrofPRBs – 1)
Group and sequence hopping	neither
Hopping ID	0
Initial cyclic shift	0
First symbol	0
Index of orthogonal cover code ( <i>timeDomainOCC</i> )	0

- 6) The multipath fading emulators shall be configured according to the corresponding channel model defined in annex J.2.
- 7) Adjust the test signal mean power so the calibrated radiated SNR value at the BS receiver is as specified in clause 8.3.2.2.5.1 and 8.3.2.2.5.2 for BS type 1-O and BS type 2-O respectively, and that the SNR at the BS receiver is not impacted by the noise floor.

The power level for the transmission may be set such that the AWGN level at the RIB is equal to the AWGN level in table 8.3.2.2.4.2-2.

**Table 8.3.2.2.4.2-2: AWGN power level at the BS input**

BS type	Subcarrier spacing (kHz)	Channel bandwidth (MHz)	AWGN power level
BS type 1-O (Note 4)	15 kHz	5	$-83.5 - \Delta_{\text{OTAREFSSENS}}$ dBm / 4.5 MHz
		10	$-80.3 - \Delta_{\text{OTAREFSSENS}}$ dBm / 9.36 MHz
		20	$-77.2 - \Delta_{\text{OTAREFSSENS}}$ dBm / 19.08 MHz
	30 kHz	10	$-80.6 - \Delta_{\text{OTAREFSSENS}}$ dBm / 8.64 MHz
		20	$-77.4 - \Delta_{\text{OTAREFSSENS}}$ dBm / 18.36 MHz
		40	$-74.2 - \Delta_{\text{OTAREFSSENS}}$ dBm / 38.16 MHz
BS type 2-O (Note 5)	60 kHz	50	$\text{EIS}_{\text{REFSENS\_50M}} + \Delta_{\text{FR2\_REFSENS}} + 15$ dBm / 47.52 MHz
		100	$\text{EIS}_{\text{REFSENS\_50M}} + \Delta_{\text{FR2\_REFSENS}} + 18$ dBm / 95.04 MHz
	120 kHz	50	$\text{EIS}_{\text{REFSENS\_50M}} + \Delta_{\text{FR2\_REFSENS}} + 15$ dBm / 46.08 MHz
		100	$\text{EIS}_{\text{REFSENS\_50M}} + \Delta_{\text{FR2\_REFSENS}} + 18$ dBm / 95.04 MHz
		200	$\text{EIS}_{\text{REFSENS\_50M}} + \Delta_{\text{FR2\_REFSENS}} + 21$ dBm / 47.52 MHz
	480 kHz	400	$\text{EIS}_{\text{REFSENS\_50M}} + \Delta_{\text{FR2\_REFSENS}} + 24$ dBm / 380.16 MHz
		400	$\text{EIS}_{\text{REFSENS\_50M}} + \Delta_{\text{FR2\_REFSENS}} + 24$ dBm / 380.16 MHz
NOTE 1: $\Delta_{\text{OTAREFSSENS}}$ as declared in D.53 in table 4.6-1 and clause 7.1.			
NOTE 2: $\Delta_{\text{FR2\_REFSENS}} = -3$ dB as described in clause 7.1, since the OTA REFSSENS reference direction (as declared in D.54 in table 4.6-1) is used for testing.			
NOTE 3: $\text{EIS}_{\text{REFSENS\_50M}}$ as declared in D.28 in table 4.6-1.			
NOTE 4: The AWGN power level contains an AWGN offset of 16dB by default. If needed for test purposes, the AWGN level can be reduced from the default by any value in the range 0dB to 16dB. Changing the AWGN level does not impact the validity of the test, as it reduces the effective base band SNR level.			
NOTE 5: The AWGN power level contains an AWGN offset of 15dB by default. If needed for test purposes, the AWGN level can be reduced from the default by any value in the range 0dB to 15dB. Changing the AWGN level does not impact the validity of the test, as it reduces the effective base band SNR level.			

- 8) The signal generator sends random codewords from applicable codebook, in regular time periods. The following statistics are kept: the number of ACK bits falsely detected in the idle periods and the number of missed ACK bits. Each falsely detected ACK bit in the idle periods is accounted as one error for the statistics of false ACK detection, and each missed ACK bit is accounted as one error for the statistics of missed ACK detection.

Note that the procedure described in this clause for ACK missed detection has the same condition as that described in clause 8.3.2.1.4.2 for NACK to ACK detection. Both statistics are measured in the same testing.

**Figure 8.3.2.2.4.2-1: Void**



## 8.3.2.2.5 Test Requirement

## 8.3.2.2.5.1 Test Requirement for BS type 1-O

The fraction of falsely detected ACK bits shall be less than 1% and the fraction of correctly detected ACK bits shall be larger than 99% for the SNR listed in tables 8.3.2.2.5-1 and table 8.3.2.2.5-2.

Table 8.3.2.2.5.1-1: Required SNR for PUCCH format 1 with 15 kHz SCS

Number of TX antennas	Number of Demodulation Branches	Cyclic Prefix	Propagation conditions and correlation matrix (annex J)	Channel bandwidth / SNR (dB)		
				5 MHz	10 MHz	20 MHz
1	2	Normal	TDLC300-100 Low	-4.4	-3.8	-4.4

Table 8.3.2.2.5.1-2: Required SNR for PUCCH format 1 with 30 kHz SCS

Number of TX antennas	Number of Demodulation Branches	Cyclic Prefix	Propagation conditions and correlation matrix (annex J)	Channel bandwidth / SNR (dB)			
				10 MHz	20 MHz	40 MHz	100 MHz
1	2	Normal	TDLC300-100 Low	-3.3	-3.8	-3.8	-3.6

## 8.3.2.2.5.2 Test Requirement for BS type 2-O

The fraction of falsely detected ACK bits shall be less than 1% and the fraction of correctly detected ACK bits shall be larger than 99% for the SNR listed in tables 8.3.2.2.5.2-1 to table 8.3.2.2.5.2-4.

Table 8.3.2.2.5.2-1: Required SNR for PUCCH format 1 with 60 kHz SCS in FR2-1

Number of TX antennas	Number of Demodulation Branches	Cyclic Prefix	Propagation conditions and correlation matrix (annex J)	Channel bandwidth / SNR (dB)	
				50 MHz	100 MHz
1	2	Normal	TDLA30-300 Low	-3.3	-3.6

Table 8.3.2.2.5.2-2: Required SNR for PUCCH format 1 with 120 kHz SCS in FR2-1

Number of TX antennas	Number of Demodulation Branches	Cyclic Prefix	Propagation conditions and correlation matrix (annex J)	Channel bandwidth / SNR (dB)		
				50 MHz	100 MHz	200 MHz
1	2	Normal	TDLA30-300 Low	-4.1	-4.0	-4.0

Table 8.3.2.2.5.2-3: Required SNR for PUCCH format 1 and 120 kHz SCS in FR2-2

Number of TX antennas	Number of demodulation branches	Cyclic Prefix	Propagation conditions and correlation matrix (annex J)	Number of PRB	Channel bandwidth / SNR (dB)
					100 MHz
1	2	Normal	TDLA30-650 Low	1	-2.1
				16	-12.5

Table 8.3.2.5.2-4: Required SNR for PUCCH format 1 and 480 kHz SCS in FR2-2

Number of TX antennas	Number of demodulation branches	Cyclic Prefix	Propagation conditions and correlation matrix (annex J)	Number of PRB	Channel bandwidth / SNR (dB)
					400 MHz
1	2	Normal	TDLA10-650 Low	1	-2.3
				16	-13.2

### 8.3.3 Performance requirements for PUCCH format 2

#### 8.3.3.1 ACK missed detection performance requirements

##### 8.3.3.1.1 Definition and applicability

The performance requirement of PUCCH format 2 for ACK missed detection is determined by the two parameters: probability of false detection of the ACK and the probability of detection of ACK on the wanted signal. The performance is measured by the required SNR at probability of detection equal to 0.99. The probability of false detection of the ACK shall be 0.01 or less.

The probability of false detection of the ACK is defined as a probability of erroneous detection of the ACK when input is only noise.

The probability of detection of ACK is defined as probability of detection of the ACK when the signal is present.

Which specific test(s) are applicable to BS is based on the test applicability rules defined in clause 8.1.2.

##### 8.3.3.1.2 Minimum Requirement

For *BS type 1-O*, the minimum requirement is in TS 38.104 [2] clause 11.3.1.4.

For *BS type 2-O*, the minimum requirement is in TS 38.104 [2] clause 11.3.2.4.

##### 8.3.3.1.3 Test Purpose

The test shall verify the receiver's ability to detect ACK bits under multipath fading propagation conditions for a given SNR.

##### 8.3.3.1.4 Method of test

###### 8.3.3.1.4.1 Initial conditions

Test environment: Normal, see clause B.2.

RF channels to be tested for single carrier;M; see clause 4.9.1

Direction to be tested: OTA REFSENS *receiver target reference direction* (see D.54 in table.4.6-1).

###### 8.3.3.1.4.2 Procedure

- 1) Place the BS with its manufacturer declared coordinate system reference point in the same place as calibrated point in the test system, as shown in annex E.3.
- 2) Align the manufacturer declared coordinate system orientation of the BS with the test system.
- 3) Set the BS in the declared direction to be tested.
- 4) Connect the BS tester generating the wanted signal, multipath fading simulators and AWGN generators to a test antenna via a combining network in OTA test setup, as shown in annex E.3. Each of the demodulation branch signals should be transmitted one polarization of the test antenna(s).

- 5) The characteristics of the wanted signal shall be configured according to TS 38.211 [20], and according to additional test parameters listed in table 8.3.3.1.4.2-1.

**Table 8.3.3.1.4.2-1: Test parameters**

Parameter	Value
Modulation order	QPSK
Starting RB location	0
Intra-slot frequency hopping	N/A
Number of PRBs	4
Number of symbols	1
The number of UCI information bits	4
First symbol	13
DM-RS sequence generation	$N_{ID}^0=0$

- 6) The multipath fading emulators shall be configured according to the corresponding channel model defined in annex J.
- 7) Adjust the test signal mean power so the calibrated radiated SNR value at the BS receiver is as specified in clause 8.3.3.1.5.1 and 8.3.3.1.5.2 for *BS type 1-O* and *BS type 2-O* respectively, and that the SNR at the BS receiver is not impacted by the noise floor.

The power level for the transmission may be set such that the AWGN level at the RIB is equal to the AWGN level in table 8.3.3.1.4.2-2.

**Table 8.3.3.1.4.2-2: AWGN power level at the BS input**

BS type	Sub-carrier spacing (kHz)	Channel bandwidth (MHz)	AWGN power level	
BS type 1-O (Note 4)	15 kHz	5	-83.5 - $\Delta_{OTAREFSENS}$ dBm / 4.5 MHz	
		10	-80.3 - $\Delta_{OTAREFSENS}$ dBm / 9.36 MHz	
		20	-77.2 - $\Delta_{OTAREFSENS}$ dBm / 19.08 MHz	
	30 kHz	10	-80.6 - $\Delta_{OTAREFSENS}$ dBm / 8.64 MHz	
		20	-77.4 - $\Delta_{OTAREFSENS}$ dBm / 18.36 MHz	
		40	-74.2 - $\Delta_{OTAREFSENS}$ dBm / 38.16 MHz	
BS type 2-O (Note 5)	60 kHz	50	$EIS_{REFSENS\_50M} + \Delta_{FR2\_REFSENS} + 15$ dBm / 47.52MHz	
		100	$EIS_{REFSENS\_50M} + \Delta_{FR2\_REFSENS} + 18$ dBm / 95.04 MHz	
	120 kHz	50	$EIS_{REFSENS\_50M} + \Delta_{FR2\_REFSENS} + 15$ dBm / 46.08 MHz	
		100	$EIS_{REFSENS\_50M} + \Delta_{FR2\_REFSENS} + 18$ dBm / 95.04 MHz	
		200	$EIS_{REFSENS\_50M} + \Delta_{FR2\_REFSENS} + 21$ dBm / 190.08 MHz	
		400	$EIS_{REFSENS\_50M} + \Delta_{FR2\_REFSENS} + 24$ dBm / 380.16 MHz	
	480 kHz	400	$EIS_{REFSENS\_50M} + \Delta_{FR2\_REFSENS} + 24$ dBm / 380.16 MHz	
	<p>NOTE 1: <math>\Delta_{OTAREFSENS}</math> as declared in D.53 in table 4.6-1 and clause 7.1.</p> <p>NOTE 2: <math>\Delta_{FR2\_REFSENS} = -3</math> dB as declared in clause 7.1, since the OTA REFSENS receiver target reference direction (as declared in D.54 in table 4.6-1) is used for testing.</p> <p>NOTE 3: <math>EIS_{REFSENS\_50M}</math> as declared in D.28 in table 4.6-1.</p> <p>NOTE 4: The AWGN power level contains an AWGN offset of 16dB by default. If needed for test purposes, the AWGN level can be reduced from the default by any value in the range 0dB to 16dB. Changing the AWGN level does not impact the validity of the test, as it reduces the effective base band SNR level.</p> <p>NOTE 5: The AWGN power level contains an AWGN offset of 15dB by default. If needed for test purposes, the AWGN level can be reduced from the default by any value in the range 0dB to 15dB. Changing the AWGN level does not impact the validity of the test, as it reduces the effective base band SNR level.</p>			

8) The signal generator sends a test pattern with pattern outlined in figure 8.3.3.1.4.2-1. The following statistics are kept: the number of ACK bits detected in the idle periods and the number of missed ACKs.

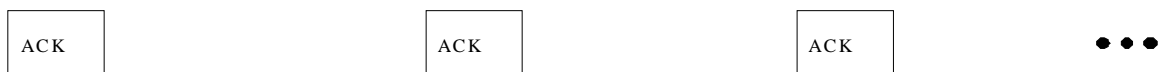

**Figure 8.3.3.1.4.2-1: Test signal pattern for PUCCH format 2 demodulation tests**

8.3.3.1.5 Test requirement

8.3.3.1.5.1 Requirements for BS type 1-O

The fraction of falsely detected ACKs shall be less than 1% and the fraction of correctly detected ACKs shall be larger than 99% for the SNR listed in table 8.3.3.1.5.1-1 and table 8.3.3.1.5.1-2.

**Table 8.3.3.1.5.1-1: Required SNR for PUCCH format 2 with 15 kHz SCS**

Number of TX antennas	Number of demodulation branches	Cyclic Prefix	Propagation conditions and correlation matrix (annex J)	Channel bandwidth / SNR (dB)		
				5 MHz	10 MHz	20 MHz
1	2	Normal	TDLC300-100 Low	6.4	6.2	6.5

**Table 8.3.3.1.5.1-2: Required SNR for PUCCH format 2 with 30 kHz SCS**

Number of TX antennas	Number of demodulation branches	Cyclic Prefix	Propagation conditions and correlation matrix (annex J)	Channel bandwidth/ SNR (dB)			
				10MHz	20 MHz	40MHz	100MHz
1	2	Normal	TDLC300-100 Low	6.1	6.2	6.1	6.3

### 8.3.3.1.5.2 Requirements for BS type 2-O

The fraction of falsely detected ACKs shall be less than 1% and the fraction of correctly detected ACKs shall be larger than 99% for the SNR listed in table 8.3.3.1.5.2-1 to table 8.3.3.1.5.2-4.

**Table 8.3.3.1.5.2-1: Required SNR for PUCCH format 2 with 60 kHz SCS in FR2-1**

Number of TX antennas	Number of demodulation branches	Cyclic Prefix	Propagation conditions and correlation matrix (annex J)	Channel bandwidth / SNR (dB)	
				50 MHz	100 MHz
1	2	Normal	TDLA30-300 Low	7.3	7.8

**Table 8.3.3.1.5.2-2: Required SNR for PUCCH format 2 with 120 kHz SCS in FR2-1**

Number of TX antennas	Number of demodulation branches	Cyclic Prefix	Propagation conditions and correlation matrix (annex J)	Channel bandwidth / SNR (dB)		
				50 MHz	100 MHz	200 MHz
1	2	Normal	TDLA30-300 Low	7.2	6.9	7.2

**Table 8.3.3.1.5.2-3: Required SNR for PUCCH format 2 and 120 kHz SCS in FR2-2**

Number of TX antennas	Number of demodulation branches	Cyclic Prefix	Propagation conditions and correlation matrix (annex J)	Channel bandwidth / SNR (dB)
				100 MHz
1	2	Normal	TDLA30-650 Low	6

**Table 8.3.3.1.5.2-4: Required SNR for PUCCH format 2 and 480 kHz SCS in FR2-2**

Number of TX antennas	Number of demodulation branches	Cyclic Prefix	Propagation conditions and correlation matrix (annex J)	Channel bandwidth / SNR (dB)
				400 MHz
1	2	Normal	TDLA10-650 Low	6

## 8.3.3.2 UCI BLER performance requirements

### 8.3.3.2.1 Definition and applicability

The UCI block error probability is defined as the probability of incorrectly decoding the UCI information when the UCI information is sent. The UCI information does not contain CSI part 2.

Which specific test(s) are applicable to BS is based on the test applicability rules defined in clause 8.1.2.

The transient period as specified in TS 38.101-1 [24] and TS 38.101-2 [25] clause 6.3.3.1 is not taken into account for performance requirement testing, where the RB hopping is symmetric to the CC center, i.e., intra-slot frequency hopping is enabled.

### 8.3.3.2.2 Minimum Requirement

For *BS type 1-O*, the minimum requirement is in TS 38.104 [2] clause 11.3.1.4.

For *BS type 2-O*, the minimum requirement is in TS 38.104 [2] clause 11.3.2.4.

### 8.3.3.2.3 Test Purpose

The test shall verify the receiver's ability to detect UCI under multipath fading propagation conditions for a given SNR.

### 8.3.3.2.4 Method of test

#### 8.3.3.2.4.1 Initial conditions

Test environment: Normal, see clause B.2.

RF channels to be tested for single carrier: M; see clause 4.9.1

Direction to be tested: OTA REFSSENS *receiver target reference direction* (see D.54 in table 4.6-1).

#### 8.3.3.2.4.2 Procedure

- 1) Place the BS with its manufacturer declared coordinate system reference point in the same place as calibrated point in the test system, as shown in annex E.3.
- 2) Align the manufacturer declared coordinate system orientation of the BS with the test system.
- 3) Set the BS in the declared direction to be tested.
- 4) Connect the BS tester generating the wanted signal, multipath fading simulators and AWGN generators to a test antenna via a combining network in OTA test setup, as shown in annex E.3. Each of the demodulation branches signals should be transmitted on each polarization of the test antenna(s).
- 5) The characteristics of the wanted signal shall be configured according to TS 38.211 [20], and according to additional test parameters listed in table 8.3.3.2.4.2-1.

**Table 8.3.3.2.4.2-1: Test parameters**

Parameter	Value
Modulation order	QPSK
First PRB prior to frequency hopping	0
Intra-slot frequency hopping	enabled
First PRB after frequency hopping	The largest PRB index - (Number of PRBs-1) (Note 1)
Number of PRBs	9
Number of symbols	2
The number of UCI information bits	22
First symbol	12
DM-RS sequence generation	$N_{ID}^0=0$
Note 1: For 3MHz, the first PRB after frequency hopping is 3	

- 6) The multipath fading emulators shall be configured according to the corresponding channel model defined in annex J.
- 7) Adjust the test signal mean power so the calibrated radiated SNR value at the BS receiver is as specified in clause 8.3.3.2.5.1 and 8.3.3.2.5.2 for *BS type 1-O* and *BS type 2-O* respectively, and that the SNR at the BS receiver is not impacted by the noise floor.

The power level for the transmission may be set such that the AWGN level at the RIB is equal to the AWGN level in table 8.3.3.2.4.2-2.

**Table 8.3.3.2.4.2-2: AWGN power level at the BS input**

BS type	Sub-carrier spacing (kHz)	Channel bandwidth (MHz)	AWGN power level	
BS type 1-O (Note 4)	15 kHz	3	-88.7- $\Delta_{OTAREFSENS}$ dBm / 2.7 MHz	
		5	-83.5 - $\Delta_{OTAREFSENS}$ dBm / 4.5MHz	
		10	-80.3 - $\Delta_{OTAREFSENS}$ dBm / 9.36 MHz	
		20	-77.2 - $\Delta_{OTAREFSENS}$ dBm / 19.08 MHz	
	30 kHz	10	-80.6 - $\Delta_{OTAREFSENS}$ dBm / 8.64 MHz	
		20	-77.4 - $\Delta_{OTAREFSENS}$ dBm / 18.36 MHz	
		40	-74.2 - $\Delta_{OTAREFSENS}$ dBm / 38.16 MHz	
BS type 2-O (Note 5)	60 kHz	50	$EIS_{REFSENS\_50M} + \Delta_{FR2\_REFSENS} + 15$ dBm / 47.52MHz	
		100	$EIS_{REFSENS\_50M} + \Delta_{FR2\_REFSENS} + 18$ dBm / 95.04 MHz	
	120 kHz	50	$EIS_{REFSENS\_50M} + \Delta_{FR2\_REFSENS} + 15$ dBm / 46.08 MHz	
		100	$EIS_{REFSENS\_50M} + \Delta_{FR2\_REFSENS} + 18$ dBm / 95.04 MHz	
		200	$EIS_{REFSENS\_50M} + \Delta_{FR2\_REFSENS} + 21$ dBm / 190.08 MHz	
		400	$EIS_{REFSENS\_50M} + \Delta_{FR2\_REFSENS} + 24$ dBm / 380.16 MHz	
	480 kHz	400	$EIS_{REFSENS\_50M} + \Delta_{FR2\_REFSENS} + 24$ dBm / 380.16 MHz	
	NOTE 1: $\Delta_{OTAREFSENS}$ as declared in D.53 in table 4.6-1 and clause 7.1.			
	NOTE 2: $\Delta_{FR2\_REFSENS} = -3$ dB as declared in clause 7.1.			
	NOTE 3: $EIS_{REFSENS\_50M}$ as declared in D.28 in table 4.6-1.			
NOTE 4: The AWGN power level contains an AWGN offset of 16dB by default. If needed for test purposes, the AWGN level can be reduced from the default by any value in the range 0dB to 16dB. Changing the AWGN level does not impact the validity of the test, as it reduces the effective base band SNR level.				
NOTE 5: The AWGN power level contains an AWGN offset of 15dB by default. If needed for test purposes, the AWGN level can be reduced from the default by any value in the range 0dB to 15dB. Changing the AWGN level does not impact the validity of the test, as it reduces the effective base band SNR level.				

8) The signal generator sends a test pattern with the pattern outlined in figure 8.3.3.2.4.2-1. The following statistics are kept: the number of incorrectly decoded UCI.



**Figure 8.3.3.2.4.2-1: Test signal pattern for PUCCH format 2 demodulation tests**

8.3.3.2.5 Test requirement

8.3.3.2.5.1 Requirements for BS type 1-O

The fraction of incorrectly decoded UCI is shall be less than 1% for the SNR listed in table 8.3.3.2.5.1-1 and table 8.3.3.2.5.1-2.

**Table 8.3.3.2.5.1-1: Required SNR for PUCCH format 2 with 15 kHz SCS**

Number of TX antennas	Number of demodulation branches	Cyclic Prefix	Propagation conditions and correlation matrix (annex J)	Channel bandwidth / SNR (dB)			
				3 MHz	5 MHz	10 MHz	20 MHz
1	2	Normal	TDLC300-100 Low	2.1	0.8	1.4	1.8

**Table 8.3.3.2.5.1-2: Required SNR for PUCCH format 2 with 30 kHz SCS**

Number of TX antennas	Number of demodulation branches	Cyclic Prefix	Propagation conditions and correlation matrix (annex J)	Channel bandwidth/ SNR (dB)			
				10MHz	20 MHz	40MHz	100MHz
1	2	Normal	TDLC300-100 Low	1.1	1.7	1.0	0.9

### 8.3.3.2.5.2 Requirements for BS type 2-0

The fraction of incorrectly decoded UCI is shall be less than 1% for the SNR listed in table 8.3.3.2.5.2-1 to table 8.3.3.2.5.2-4.

**Table 8.3.3.2.5.2-1: Required SNR for PUCCH format 2 with 60 kHz SCS in FR2-1**

Number of TX antennas	Number of demodulation branches	Cyclic Prefix	Propagation conditions and correlation matrix (annex J)	Channel bandwidth / SNR (dB)	
				50 MHz	100 MHz
1	2	Normal	TDLA30-300 Low	3.2	1.7

**Table 8.3.3.2.5.2-2: Required SNR for PUCCH format 2 with 120 kHz SCS in FR2-1**

Number of TX antennas	Number of demodulation branches	Cyclic Prefix	Propagation conditions and correlation matrix (annex J)	Channel bandwidth / SNR (dB)		
				50 MHz	100 MHz	200 MHz
1	2	Normal	TDLA30-300 Low	1.8	1.8	1.7

**Table 8.3.3.2.5.2-3: Required SNR for PUCCH format 2 and 120 kHz SCS in FR2-2**

Number of TX antennas	Number of demodulation branches	Cyclic Prefix	Propagation conditions and correlation matrix (annex J)	Channel bandwidth / SNR (dB)
				100 MHz
1	2	Normal	TDLA30-650 Low	2.7

**Table 8.3.3.2.5.2-4: Required SNR for PUCCH format 2 and 480 kHz SCS in FR2-2**

Number of TX antennas	Number of demodulation branches	Cyclic Prefix	Propagation conditions and correlation matrix (annex J)	Channel bandwidth / SNR (dB)
				400 MHz
1	2	Normal	TDLA10-650 Low	3.2

## 8.3.4 Performance requirements for PUCCH format 3

### 8.3.4.1 Definition and applicability

The performance is measured by the required SNR at UCI block error probability not exceeding 1%.

The UCI block error probability is defined as the conditional probability of incorrectly decoding the UCI information when the UCI information is sent. The UCI information does not contain CSI part 2.

The transient period as specified in TS 38.101-1 [24] clause 6.3.3.1 and TS 38.101-2 [25] clause 6.3.3.1 is not taken into account for performance requirement testing, where the RB hopping is symmetric to the CC center, i.e. intra-slot frequency hopping is enabled.

Which specific test(s) are applicable to BS is based on the test applicability rules defined in clause 8.1.2.2.



### 8.3.4.2 Minimum requirement

For *BS type 1-O*, the minimum requirement is in TS 38.104 [2], clause 11.3.1.5.

For *BS type 2-O*, the minimum requirement is in TS 38.104 [2], clause 11.3.2.5.

### 8.3.4.3 Test purpose

The test shall verify the receiver's ability to detect UCI under multipath fading propagation conditions for a given SNR.

### 8.3.4.4 Method of test

#### 8.3.4.4.1 Initial conditions

Test environment: Normal; see annex B.2.

RF channels to be tested for single carrier: M; see clause 4.9.1

Direction to be tested:

- OTA REFSENS *receiver target reference direction* (see D.54 in table 4.6-1).

#### 8.3.4.4.2 Procedure

- 1) Place the BS with its manufacturer declared coordinate system reference point in the same place as calibrated point in the test system, as shown in annex E.3.
- 2) Align the manufacturer declared coordinate system orientation of the BS with the test system.
- 3) Set the BS in the declared direction to be tested.
- 4) Connect the BS tester generating the wanted signal, multipath fading simulators and AWGN generators to a test antenna via a combining network in OTA test setup, as shown in annex E.3. Each of the demodulation branch signals should be transmitted on one polarization of the test antenna(s).
- 5) The characteristics of the wanted signal shall be configured according to TS 38.211 [20], and according to additional test parameters listed in table 8.3.4.4.2-1.

**Table 8.3.4.4.2-1: Test parameters**

Parameter	Test 1	Test 2
Modulation order	QPSK	
First PRB prior to frequency hopping	0	
Intra-slot frequency hopping	enabled	
First PRB after frequency hopping	The largest PRB index - (Number of PRBs -1)	
Group and sequence hopping	neither	
Hopping ID	0	
Number of PRBs	1	3
Number of symbols	14	4
The number of UCI information bits	16	16
First symbol	0	0

- 6) The multipath fading emulators shall be configured according to the corresponding channel model defined in annex J.
- 7) Adjust the test signal mean power so the calibrated radiated SNR value at the BS receiver is as specified in clause 8.3.4.5.1 and 8.3.4.5.2 for *BS type 1-O* and *BS type 2-O* respectively, and the SNR at the BS receiver is not impacted by the noise floor.

The power level for the transmission may be set such that the AWGN level at the RIB is equal to the AWGN level in table 8.3.4.4.2-2.

Table 8.3.4.4.2-2: AWGN power level at the BS input

BS type	Subcarrier spacing (kHz)	Channel bandwidth (MHz)	AWGN power level
BS type 1-O (Note 4)	15	5	-83.5 - $\Delta_{OTAREFSENS}$ dBm / 4.5MHz
		10	-80.3 - $\Delta_{OTAREFSENS}$ dBm / 9.36MHz
		20	-77.2 - $\Delta_{OTAREFSENS}$ dBm / 19.08MHz
	30	10	-80.6 - $\Delta_{OTAREFSENS}$ dBm / 8.64MHz
		20	-77.4 - $\Delta_{OTAREFSENS}$ dBm / 18.36MHz
		40	-74.2 - $\Delta_{OTAREFSENS}$ dBm / 38.16MHz
BS type 2-O (Note 5)	60	50	EIS <sub>REFSENS_50M</sub> + $\Delta_{FR2\_REFSENS}$ + 15 dBm / 47.52MHz
		100	EIS <sub>REFSENS_50M</sub> + $\Delta_{FR2\_REFSENS}$ + 18 dBm / 95.04 MHz
	120	50	EIS <sub>REFSENS_50M</sub> + $\Delta_{FR2\_REFSENS}$ + 15 dBm / 46.08 MHz
		100	EIS <sub>REFSENS_50M</sub> + $\Delta_{FR2\_REFSENS}$ + 18 dBm / 95.04 MHz
		200	EIS <sub>REFSENS_50M</sub> + $\Delta_{FR2\_REFSENS}$ + 21 dBm / 190.08 MHz
	480	400	EIS <sub>REFSENS_50M</sub> + $\Delta_{FR2\_REFSENS}$ + 24 dBm / 380.16 MHz
		400	EIS <sub>REFSENS_50M</sub> + $\Delta_{FR2\_REFSENS}$ + 24 dBm / 380.16 MHz

NOTE 1:  $\Delta_{OTAREFSENS}$  as declared in D.53 in table 4.6-1 and clause 7.1.  
NOTE 2:  $\Delta_{FR2\_REFSENS}$  = -3 dB as described in clause 7.1, since the OTA REFSENS receiver target reference direction (as declared in D.54 in table 4.6-1) is used for testing.  
NOTE 3: EIS<sub>REFSENS\_50M</sub> as declared in D.28 in table 4.6-1.  
NOTE 4: The AWGN power level contains an AWGN offset of 16dB by default. If needed for test purposes, the AWGN level can be reduced from the default by any value in the range 0dB to 16dB. Changing the AWGN level does not impact the validity of the test, as it reduces the effective base band SNR level.  
NOTE 5: The AWGN power level contains an AWGN offset of 15dB by default. If needed for test purposes, the AWGN level can be reduced from the default by any value in the range 0dB to 15dB. Changing the AWGN level does not impact the validity of the test, as it reduces the effective base band SNR level.

### 8.3.4.5 Test requirement

#### 8.3.4.5.1 Test requirement for BS type 1-O

The fraction of incorrectly decoded UCI is shall be less than 1% for the SNR listed in table 8.3.4.5.1-1 and table 8.3.4.5.1-2.

Table 8.3.4.5.1-1: Required SNR for PUCCH format 3 with 15 kHz SCS

Test Number	Number of TX antennas	Number of demodulation branches	Cyclic Prefix	Propagation conditions and correlation matrix (annex J)	Additional DM-RS configuration	Channel bandwidth / SNR (dB)		
						5 MHz	10 MHz	20 MHz
1	1	2	Normal	TDLC300-100 Low	No additional DM-RS	0.8	1.7	0.9
					Additional DM-RS	0.5	1.1	0.5
2	1	2	Normal	TDLC300-100 Low	No additional DM-RS	2.0	2.8	2.6

Table 8.3.4.5.1-2: Required SNR for PUCCH format 3 with 30 kHz SCS

Test Number	Number of TX antennas	Number of demodulation branches	Cyclic Prefix	Propagation conditions and correlation matrix (annex J)	Additional DM-RS configuration	Channel bandwidth / SNR (dB)			
						10 MHz	20 MHz	40 MHz	100 MHz
1	1	2	Normal	TDLC300-100 Low	No additional DM-RS	1.5	1.2	1.2	1.5
					Additional DM-RS	1.1	0.9	0.6	0.7
2	1	2	Normal	TDLC300-100 Low	No additional DM-RS	2.4	2.6	2.6	2.1

8.3.4.5.2 Test requirement for *BS type 2-0*

The fraction of incorrectly decoded UCI is shall be less than 1% for the SNR listed in table 8.3.4.5.2-1 to table 8.3.4.5.2-4.

Table 8.3.4.5.2-1: Required SNR for PUCCH format 3 with 60 kHz SCS in FR2-1

Test Number	Number of TX antennas	Number of demodulation branches	Cyclic Prefix	Propagation conditions and correlation matrix (annex J)	Additional DM-RS configuration	Channel bandwidth / SNR (dB)	
						50 MHz	100 MHz
1	1	2	Normal	TDLA30-300 Low	No additional DM-RS	2.2	1.3
					Additional DM-RS	1.9	1.5
2	1	2	Normal	TDLA30-300 Low	No additional DM-RS	3.6	3.0

Table 8.3.4.5.2-2: Required SNR for PUCCH format 3 with 120 kHz SCS in FR2-1

Test Number	Number of TX antennas	Number of demodulation branches	Cyclic Prefix	Propagation conditions and correlation matrix (annex J)	Additional DM-RS configuration	Channel bandwidth / SNR (dB)		
						50 MHz	100 MHz	200 MHz
1	1	2	Normal	TDLA30-300 Low	No additional DM-RS	2.0	1.3	1.3
					Additional DM-RS	1.9	2.0	1.5
2	1	2	Normal	TDLA30-300 Low	No additional DM-RS	1.7	3.5	2.0

Table 8.3.4.5.2-3: Required SNR for PUCCH format 3 with 120 kHz SCS in FR2-2

Test Number	Number of TX antennas	Number of demodulation branches	Cyclic Prefix	Propagation conditions and correlation matrix (annex J)	Additional DM-RS configuration	Channel bandwidth / SNR (dB)
						100 MHz
1	1	2	Normal	TDLA30-650 Low	No additional DM-RS	1.2
					Additional DM-RS	1.3
2	1	2	Normal	TDLA30-650 Low	No additional DM-RS	2.4

Table 8.3.4.5.2-4: Required SNR for PUCCH format 3 with 480 kHz SCS in FR2-2

Test Number	Number of TX antennas	Number of demodulation branches	Cyclic Prefix	Propagation conditions and correlation matrix (annex J)	Additional DM-RS configuration	Channel bandwidth / SNR (dB)
						400 MHz
1	1	2	Normal	TDLA10-650 Low	No additional DM-RS	1
					Additional DM-RS	1.1
2	1	2	Normal	TDLA10-650 Low	No additional DM-RS	2.6

## 8.3.5 Performance requirements for PUCCH format 4

### 8.3.5.1 Definition and applicability

The performance is measured by the required SNR at UCI block error probability not exceeding 1%.

The UCI block error probability is defined as the conditional probability of incorrectly decoding the UCI information when the UCI information is sent. The UCI information does not contain CSI part 2.

The transient period as specified in TS 38.101-1 [24] and TS 38.101-2 [25] clause 6.3.3.1 is not taken into account for performance requirement testing, where the RB hopping is symmetric to the CC center, i.e. intra-slot frequency hopping is enabled.

Which specific test(s) are applicable to BS is based on the test applicability rules defined in clause 8.1.2.2.

### 8.3.5.2 Minimum requirement

For *BS type 1-O*, the minimum requirement is in TS 38.104 [2], clause 11.3.1.6.

For *BS type 2-O*, the minimum requirement is in TS 38.104 [2], clause 11.3.2.6.

### 8.3.5.3 Test purpose

The test shall verify the receiver's ability to detect UCI under multipath fading propagation conditions for a given SNR.

### 8.3.5.4 Method of test

#### 8.3.5.4.1 Initial conditions

Test environment: Normal; see annex B.2.

RF channels to be tested for single carrier: M; see clause 4.9.1

Direction to be tested:

- OTA REFSSENS *receiver target reference direction* (see D.54 in table 4.6-1).

#### 8.3.5.4.2 Procedure

- 1) Place the BS with its manufacturer declared coordinate system reference point in the same place as calibrated point in the test system, as shown in annex E.3.
- 2) Align the manufacturer declared coordinate system orientation of the BS with the test system.
- 3) Set the BS in the declared direction to be tested.

- 4) Connect the BS tester generating the wanted signal, multipath fading simulators and AWGN generators to a test antenna via a combining network in OTA test setup, as shown in annex E.3. Each of the demodulation branch signals should be transmitted on one polarization of the test antenna(s).
- 5) The characteristics of the wanted signal shall be configured according to TS 38.211 [20], and according to additional test parameters listed in table 8.3.4.4.2-1.

**Table 8.3.5.4.2-1: Test parameters**

Parameter	Value
Modulation order	QPSK
First PRB prior to frequency hopping	0
Number of PRBs	FR1 and FR2-1: 1 FR2-2: 1, 16
Intra-slot frequency hopping	enabled
First PRB after frequency hopping	The largest PRB index - (Number of PRBs - 1)
Group and sequence hopping	neither
Hopping ID	0
Number of symbols	14
The number of UCI information bits	22
First symbol	0
Length of the orthogonal cover code	n2
Index of the orthogonal cover code	n0

- 6) The multipath fading emulators shall be configured according to the corresponding channel model defined in annex J.
- 7) Adjust the test signal mean power so the calibrated radiated SNR value at the BS receiver is as specified in clause 8.3.5.5.1 and 8.3.5.5.2 for *BS type 1-O* and *BS type 2-O* respectively, and that the SNR at the BS receiver is not impacted by the noise floor.

The power level for the transmission may be set such that the AWGN level at the RIB is equal to the AWGN level in table 8.3.5.4.2-2.

**Table 8.3.5.4.2-2: AWGN power level at the BS input**

BS type	Subcarrier spacing (kHz)	Channel bandwidth (MHz)	AWGN power level
BS type 1-O	15	5	-83.5 - $\Delta_{\text{OTAREFSENS}}$ dBm / 4.5MHz
		10	-80.3 - $\Delta_{\text{OTAREFSENS}}$ dBm / 9.36MHz
		20	-77.2 - $\Delta_{\text{OTAREFSENS}}$ dBm / 19.08MHz
	30	10	-80.6 - $\Delta_{\text{OTAREFSENS}}$ dBm / 8.64MHz
		20	-77.4 - $\Delta_{\text{OTAREFSENS}}$ dBm / 18.36MHz
		40	-74.2 - $\Delta_{\text{OTAREFSENS}}$ dBm / 38.16MHz
BS type 2-O	60	100	-70.1 - $\Delta_{\text{OTAREFSENS}}$ dBm / 98.28MHz
		50	EIS <sub>REFSENS_50M</sub> + $\Delta_{\text{FR2\_REFSENS}}$ + 15 dBm / 47.52 MHz
		100	EIS <sub>REFSENS_50M</sub> + $\Delta_{\text{FR2\_REFSENS}}$ + 18 dBm / 95.04 MHz
	120	50	EIS <sub>REFSENS_50M</sub> + $\Delta_{\text{FR2\_REFSENS}}$ + 15 dBm / 46.08 MHz
		100	EIS <sub>REFSENS_50M</sub> + $\Delta_{\text{FR2\_REFSENS}}$ + 18 dBm / 95.04 MHz
		200	EIS <sub>REFSENS_50M</sub> + $\Delta_{\text{FR2\_REFSENS}}$ + 21 dBm / 190.08 MHz
	480	400	EIS <sub>REFSENS_50M</sub> + $\Delta_{\text{FR2\_REFSENS}}$ + 24 dBm / 380.16 MHz
		400	EIS <sub>REFSENS_50M</sub> + $\Delta_{\text{FR2\_REFSENS}}$ + 24 dBm / 380.16 MHz

NOTE 1:  $\Delta_{\text{OTAREFSENS}}$  as declared in D.53 in table 4.6-1 and clause 7.1.  
NOTE 2:  $\Delta_{\text{FR2\_REFSENS}}$  = -3 dB as described in clause 7.1, since the OTA REFSENS receiver target reference direction (as declared in D.54 in table 4.6-1) is used for testing.  
NOTE 3: EIS<sub>REFSENS\_50M</sub> as declared in D.28 in table 4.6-1.

## 8.3.5.5 Test requirement

8.3.5.5.1 Test requirement for *BS type 1-O*

The fraction of incorrectly decoded UCI is shall be less than 1% for the SNR listed in table 8.3.5.5.1-1 and table 8.3.5.5.1-2.

Table 8.3.5.5.1-1: Required SNR for PUCCH format 4 with 15 kHz SCS

Number of TX antennas	Number of demodulation branches	Cyclic Prefix	Propagation conditions and correlation matrix (annex J)	Additional DM-RS configuration	Channel bandwidth / SNR (dB)		
					5 MHz	10 MHz	20 MHz
1	2	Normal	TDLC300-100 Low	No additional DM-RS	2.4	3.2	2.8
				Additional DM-RS	2.2	3.0	2.4

Table 8.3.5.5.1-2: Required SNR for PUCCH format 4 with 30 kHz SCS

Number of TX antennas	Number of demodulation branches	Cyclic Prefix	Propagation conditions and correlation matrix (annex J)	Additional DM-RS configuration	Channel bandwidth / SNR (dB)			
					10 MHz	20 MHz	40 MHz	100 MHz
1	2	Normal	TDLC300-100 Low	No additional DM-RS	3.7	3.4	3.7	3.4
				Additional DM-RS	3.4	2.9	3.7	2.8

8.3.5.5.2 Test requirement for *BS type 2-O*

The fraction of incorrectly decoded UCI is shall be less than 1% for the SNR listed in table 8.3.5.5.2-1 to table 8.3.5.5.2-4.

Table 8.3.5.5.2-1: Required SNR for PUCCH format 4 with 60 kHz SCS in FR2-1

Number of TX antennas	Number of demodulation branches	Cyclic Prefix	Propagation conditions and correlation matrix (annex J)	Additional DM-RS configuration	Channel bandwidth / SNR (dB)	
					50 MHz	100 MHz
1	2	Normal	TDLA30-300 Low	No additional DM-RS	3.6	3.3
				Additional DM-RS	3.7	4.1

Table 8.3.5.5.2-2: Required SNR for PUCCH format 4 with 120 kHz SCS in FR2-2

Number of TX antennas	Number of demodulation branches	Cyclic Prefix	Propagation conditions and correlation matrix (annex J)	Additional DM-RS configuration	Channel bandwidth / SNR (dB)		
					50 MHz	100 MHz	200MHz
1	2	Normal	TDLA30-300 Low	No additional DM-RS	3.4	3.4	4.1
				Additional DM-RS	4.2	4.4	3.8

**Table 8.3.5.5.2-3: Required SNR for PUCCH format 4 with 120 kHz SCS in FR2-2**

Number of TX antennas	Number of demodulation branches	Cyclic Prefix	Propagation conditions and correlation matrix (annex J)	Number of PRBs	Additional DM-RS configuration	Channel bandwidth / SNR (dB)
						100 MHz
1	2	Normal	TDLA30-650 Low	1	No additional DM-RS	3.6
					Additional DM-RS	3.6
1	2	Normal	TDLA30-650 Low	16	No additional DM-RS	-8.4
					Additional DM-RS	-8.3

**Table 8.3.5.5.2-4: Required SNR for PUCCH format 4 with 480 kHz SCS in FR2-2**

Number of TX antennas	Number of demodulation branches	Cyclic Prefix	Propagation conditions and correlation matrix (annex J)	Number of PRBs	Additional DM-RS configuration	Channel bandwidth / SNR (dB)
						400 MHz
1	2	Normal	TDLA10-650 Low	1	No additional DM-RS	4.2
					Additional DM-RS	4
1	2	Normal	TDLA10-650 Low	16	No additional DM-RS	-8.5
					Additional DM-RS	-8.4

## 8.3.6 Performance requirements for multi-slot PUCCH format

### 8.3.6.1 Performance requirements for multi-slot PUCCH format 1

#### 8.3.6.1.1 NACK to ACK detection

##### 8.3.6.1.1.1 Definition and applicability

The performance requirement of PUCCH format 1 for NACK to ACK detection is determined by the two parameters: probability of false detection of the ACK and the NACK to ACK detection probability. The performance is measured by the required SNR at probability of the NACK to ACK detection equal to 0.1% or less. The probability of false detection of the ACK shall be 0.01 or less.

The probability of false detection of the ACK is defined as a conditional probability of erroneous detection of the ACK at particular bit position when input is only noise. Each false bit detection is counted as one error.

The NACK to ACK detection probability is the probability of detecting an ACK bit when an NACK bit was sent on particular bit position. Each NACK bit erroneously detected as ACK bit is counted as one error. Erroneously detected NACK bits in the definition do not contain the NACK bits which are mapped from DTX, i.e. NACK bits received when DTX is sent should not be considered.

Which specific test(s) are applicable to BS is based on the test applicability rules defined in clause 8.1.2.2.

##### 8.3.6.1.1.2 Minimum Requirement

For *BS type I-O*, the minimum requirement is in TS 38.104 [2], clause 11.3.1.7.

##### 8.3.6.1.1.3 Test purpose

The test shall verify the receiver's ability not to falsely detect NACK bits as ACK bits under multipath fading propagation conditions for a given SNR.

## 8.3.6.1.1.4 Method of test

## 8.3.6.1.1.4.1 Initial conditions

Test environment: Normal; see annex B.2.

RF channels to be tested for single carrier: M; see clause 4.9.1

Direction to be tested: OTA REFSSENS *receiver target reference direction* (D.54).

## 8.3.6.1.1.4.2 Procedure

- 1) Place the BS with its manufacturer declared coordinate system reference point in the same place as calibrated point in the test system, as shown in annex E.3.
- 2) Align the manufacturer declared coordinate system orientation of the BS with the test system.
- 3) Set the BS in the declared direction to be tested.
- 4) Connect the BS tester generating the wanted signal, multipath fading simulators and AWGN generators to a test antenna via a combining network in OTA test setup, as shown in annex E.3. Each of the demodulation branch signals should be transmitted on one polarization of the test antenna(s).
- 5) The characteristics of the wanted signal shall be configured according to TS 38.211 [20], and according to additional test parameters listed in table 8.3.6.1.1.4.2-1.

**Table 8.3.6.1.1.4.2-1: Test Parameters for multi-slot PUCCH format 1**

Parameter	Test
Number of information bits	2
Number of PRBs	1
Number of symbols	14
First PRB prior to frequency hopping	0
Intra-slot frequency hopping	disabled
Inter-slot frequency hopping	enabled
First PRB after frequency hopping	The largest PRB index - (nrofPRBs - 1)
Group and sequence hopping	neither
Hopping ID	0
Initial cyclic shift	0
First symbol	0
Index of orthogonal cover code ( <i>timeDomainOCC</i> )	0
Number of slots for PUCCH repetition	2

- 6) The multipath fading emulators shall be configured according to the corresponding channel model defined in annex J.
- 7) Adjust the test signal mean power so the calibrated radiated SNR value at the BS receiver is as specified in clause 8.3.6.1.1.5.1 for *BS type I-O*, and that the SNR at the BS receiver is not impacted by the noise floor.

The power level for the transmission may be set such that the AWGN level at the RIB is equal to the AWGN level in table 8.3.6.1.1.4.2-2



**Table 8.3.6.1.1.4.2-2: AWGN power level at the BS input**

BS type	Subcarrier spacing (kHz)	Channel bandwidth (MHz)	AWGN power level
BS type 1-O (Note 4)	15 kHz	5	-83.5 – $\Delta_{OTAREFSENS}$ dBm / 4.5 MHz
		10	-80.3 – $\Delta_{OTAREFSENS}$ dBm / 9.36 MHz
		20	-77.2 – $\Delta_{OTAREFSENS}$ dBm / 19.08 MHz
	30 kHz	10	-80.6 – $\Delta_{OTAREFSENS}$ dBm / 8.64 MHz
		20	-77.4 – $\Delta_{OTAREFSENS}$ dBm / 18.36 MHz
		40	-74.2 – $\Delta_{OTAREFSENS}$ dBm / 38.16 MHz
		100	-70.1 – $\Delta_{OTAREFSENS}$ dBm / 98.28 MHz

NOTE 1:  $\Delta_{OTAREFSENS}$  as declared in D.53 in table 4.6-1 and clause 7.1.  
NOTE 2: Void. NOTE3: Void.  
NOTE 4: The AWGN power level contains an AWGN offset of 16dB by default. If needed for test purposes, the AWGN level can be reduced from the default by any value in the range 0dB to 16dB. Changing the AWGN level does not impact the validity of the test, as it reduces the effective base band SNR level..

- 8) The signal generator sends random codeword from applicable codebook, in regular time periods. The following statistics are kept: the number of ACK bits detected in the idle periods and the number of NACK bits detected as ACK.

#### 8.3.6.1.1.5 Test Requirement

##### 8.3.6.1.1.5.1 Test Requirement for *BS type 1-O*

The fraction of falsely detected ACK bits shall be less than 1% and the fraction of NACK bits falsely detected as ACK shall be less than 0.1% for the SNR listed in table 8.3.6.1.1.5.1-1.

**Table 8.3.6.1.1.5.1-1: Required SNR for multi-slot PUCCH format 1 with 30 kHz SCS**

Number of TX antennas	Number of RX antennas	Cyclic Prefix	Propagation conditions and correlation matrix (Annex J)	Channel bandwidth (MHz) / SNR (dB)
				40 MHz
1	2	Normal	TDLC-300-100 Low	-5.7

##### 8.3.6.1.1.5.2 Void

#### 8.3.6.1.2 ACK missed detection

##### 8.3.6.1.2.1 Definition and applicability

The performance requirement of PUCCH format 1 for ACK missed detection is determined by the two parameters: probability of false detection of the ACK and the probability of detection of ACK. The performance is measured by the required SNR at probability of detection equal to 0.99. The probability of false detection of the ACK shall be 0.01 or less.

The probability of false detection of the ACK is defined as a conditional probability of erroneous detection of the ACK when input is only noise.

The probability of detection of ACK is defined as conditional probability of detection of the ACK when the signal is present.

##### 8.3.6.1.2.2 Minimum Requirement

For *BS type 1-O*, the minimum requirement is in TS 38.104 [2], clause 11.3.1.7.

## 8.3.6.1.2.3 Test purpose

The test shall verify the receiver's ability to detect ACK bits under multipath fading propagation conditions for a given SNR.

## 8.3.6.1.2.4 Method of test

## 8.3.6.1.2.4.1 Initial Conditions

Test environment: Normal; see annex B.2.

RF channels to be tested for single carrier (SC): M; see clause 4.9.1

Direction to be tested: OTA REFSSENS *receiver target reference direction* (D.54).

## 8.3.6.1.2.4.2 Procedure

- 1) Place the BS with its manufacturer declared coordinate system reference point in the same place as calibrated point in the test system, as shown in annex E.3.
- 2) Align the manufacturer declared coordinate system orientation of the BS with the test system.
- 3) Set the BS in the declared direction to be tested.
- 4) Connect the BS tester generating the wanted signal, multipath fading simulators and AWGN generators to a test antenna via a combining network in OTA test setup, as shown in annex E.3. Each of the demodulation branch signals should be transmitted on one polarization of the test antenna(s).
- 5) The characteristics of the wanted signal shall be configured according to TS 38.211 [20], and according to additional test parameters listed in table 8.3.6.1.2.4.2-1.

**Table 8.3.6.1.2.4.2-1: Test Parameters for multi-slot PUCCH format 1**

Parameter	Value
Number of information bits	2
Number of PRBs	1
Number of symbols	14
First PRB prior to frequency hopping	0
Intra-slot frequency hopping	disabled
Inter-slot frequency hopping	enabled
First PRB after frequency hopping	The largest PRB index - (nrofPRBs – 1)
Group and sequence hopping	neither
Hopping ID	0
Initial cyclic shift	0
First symbol	0
Index of orthogonal cover code ( <i>timeDomainOCC</i> )	0
Number of slots for PUCCH repetition	2

- 6) The multipath fading emulators shall be configured according to the corresponding channel model defined in annex J.
- 7) Adjust the test signal mean power so the calibrated radiated SNR value at the BS receiver is as specified in clause 8.3.6.1.2.5.1 for *BS type I-O*, and that the SNR at the BS receiver is not impacted by the noise floor.

The power level for the transmission may be set such that the AWGN level at the RIB is equal to the AWGN level in table 8.3.6.1.2.4.2-2.

**Table 8.3.6.1.2.4.2-2: AWGN power level at the BS input**

BS type	Subcarrier spacing (kHz)	Channel bandwidth (MHz)	AWGN power level
BS type 1-O	15 kHz	5	-83.5 – $\Delta_{OTAREFSENS}$ dBm / 4.5 MHz
		10	-80.3 – $\Delta_{OTAREFSENS}$ dBm / 9.36 MHz
		20	-77.2 – $\Delta_{OTAREFSENS}$ dBm / 19.08 MHz
	30 kHz	10	-80.6 – $\Delta_{OTAREFSENS}$ dBm / 8.64 MHz
		20	-77.4 – $\Delta_{OTAREFSENS}$ dBm / 18.36 MHz
		40	-74.2 – $\Delta_{OTAREFSENS}$ dBm / 38.16 MHz
		100	-70.1 – $\Delta_{OTAREFSENS}$ dBm / 98.28 MHz
NOTE 1: $\Delta_{OTAREFSENS}$ as declared in D.53 in table 4.6-1 and clause 7.1.			
NOTE 2: Void.			
NOTE 3: Void.			

8) The signal generator sends a test pattern with the pattern outlined in figure 8.3.6.1.2.4.2-1. The following statistics are kept: the number of ACKs detected in the idle periods and the number of missed ACKs.



**Figure 8.3.6.1.2.4.2-1: Test signal pattern for PUCCH format 1 demodulation tests**

8.3.6.1.2.5 Test Requirement

8.3.6.1.2.5.1 Test Requirement for BS type 1-O

The fraction of falsely detected ACK bits shall be less than 1% and the fraction of correctly detected ACK bits shall be larger than 99% for the SNR listed in table 8.3.6.1.2.5.1-1.

**Table 8.3.6.1.2.5.1-1: Required SNR for multi-slot PUCCH format 1 with 30 kHz SCS**

Number of TX antennas	Number of RX antennas	Cyclic Prefix	Propagation conditions and correlation matrix (Annex J)	Channel bandwidth (MHz) / SNR (dB)
				40 MHz
1	2	Normal	TDLC-300-100 Low	-7.0

8.3.6.1.2.5.2 Void

**8.3.7 Performance requirements for interlaced PUCCH format 0**

**8.3.7.1 Definition and applicability**

The performance requirement of single user interlaced PUCCH format 0 for ACK missed detection is determined by the two parameters: probability of false detection of the ACK and the probability of detection of ACK. The performance is measured by the required SNR at probability of detection equal to 0.99. The probability of false detection of the ACK shall be 0.01 or less.

The probability of false detection of the ACK is defined as a conditional probability of erroneous detection of the ACK when input is only noise.

The probability of detection of ACK is defined as conditional probability of detection of the ACK when the signal is present.

The ACK missed detection requirement only applies to the PUCCH format 0 with 1 UCI bits. The UCI information only contains ACK information

The 1bit UCI information is further defined with bitmap as [1].

Which specific test(s) are applicable to BS is based on the test applicability rules defined in clause 8.1.2.6.

### 8.3.7.2 Minimum Requirement

For *BS type I-O*, the minimum requirements are in TS 38.104 [2] clause 11.3.1.8 and 11.3.1.9.

### 8.3.7.3 Test purpose

The test shall verify the receiver's ability to detect ACK under multipath fading propagation conditions for a given SNR.

### 8.3.7.4 Method of test

#### 8.3.7.4.1 Initial conditions

Test environment: Normal, see annex B.2.

RF channels to be tested: single carrier *M*; see clause 4.9.1.

Direction to be tested: OTA REFSENS *receiver target reference direction* (see D.54 in table 4.6-1).

#### 8.3.7.4.2 Procedure

- 1) Place the BS with its manufacturer declared coordinate system reference point in the same place as calibrated point in the test system, as shown in annex E.3.
- 2) Align the manufacturer declared coordinate system orientation of the BS with the test system.
- 3) Set the BS in the declared direction to be tested.
- 4) Connect the BS tester generating the wanted signal, multipath fading simulators and AWGN generators to a test antenna via a combining network in OTA test setup, as shown in annex E.3. Each of the demodulation branch signals should be transmitted on one polarization of the test antenna(s).
- 5) The characteristics of the wanted signal shall be configured according to TS 38.211 [20] and according to additional test parameters listed in table 8.3.7.4.2-1.

**Table 8.3.7.4.2-1: Test parameters**

Parameter	Test
Number of UCI information bits	1
Number of symbols	1
Intra-slot frequency hopping	N/A
Group and sequence hopping	neither
Hopping ID	0
Initial cyclic shift	0
First symbol	13
Number of interlaces	1
Interlace index	0 <sup>Note1</sup>
NOTE 1: RBs 0, 10, 20, ..., 100 are allocated for 15 KHz SCS and RBs 0, 5, 10, ..., 50 are allocated for 30 KHz SCS.	

- 6) The multipath fading emulators shall be configured according to the corresponding channel model defined in annex J.2.
- 7) Adjust the test signal mean power so the calibrated radiated SNR value at the BS receiver is as specified in clause 8.3.7.5.1 for *BS type I-O*, and that the SNR at the BS receiver is not impacted by the noise floor.

The power level for the transmission may be set such that the AWGN level at the RIB is equal to the AWGN level quoted in table 8.3.7.4.2-2.

**Table 8.3.7.4.2-2: AWGN power level at the BS input**

BS type	Sub-carrier spacing (kHz)	Channel bandwidth (MHz)	AWGN power level
BS type 1-O (NOTE 2)	15	20	-77.2 - $\Delta_{OTAREFSENS}$ dBm / 19.08 MHz
	30	20	-77.4 - $\Delta_{OTAREFSENS}$ dBm / 18.36 MHz
NOTE 1: $\Delta_{OTAREFSENS}$ as declared in D.53 in table 4.6-1 and clause 7.1.			
NOTE 2: The AWGN power level contains an AWGN offset of 16dB by default. If needed for test purposes, the AWGN level can be reduced from the default by any value in the range 0dB to 16dB. Changing the AWGN level does not impact the validity of the test, as it reduces the effective base band SNR level.			

8) The signal generator sends a test pattern with the pattern outlined in figure 8.3.7.4.2-1. The following statistics are kept: the number of ACKs detected in the idle periods and the number of missed ACKs.



**Figure 8.3.7.4.2-1: Test signal pattern for single user interlaced PUCCH format 0 demodulation tests**

### 8.3.7.5 Test Requirement

#### 8.3.7.5.1 Test requirement for BS type 1-0

The fraction of falsely detected ACKs shall be less than 1% and the fraction of correctly detected ACKs shall be larger than 99% for the SNR listed in table 8.3.7.5.1-1.

**Table 8.3.7.5.1-1: Test requirements for interlaced PUCCH format 0 with 15 kHz SCS, 20 MHz channel bandwidth**

Number of Tx antennas	Number of RX antennas	Propagation conditions and correlation matrix (Annex J)	Number of OFDM symbols	SNR (dB)
1	2	TDLA30-10 Low	1	-2.2

**Table 8.3.7.5.1-2: Test requirements for interlaced PUCCH format 0 with 30 kHz SCS, 20.MHz channel bandwidth**

Number of Tx antennas	Number of RX antennas	Propagation conditions and correlation matrix (Annex J)	Number of OFDM symbols	SNR (dB)
1	2	TDLA30-10 Low	1	-1.4

### 8.3.8 Performance requirements for interlaced PUCCH format 1

#### 8.3.8.1 NACK to ACK detection

##### 8.3.8.1.1 Definition and applicability

The performance requirement of interlaced PUCCH format 1 for NACK to ACK detection is determined by the two parameters: probability of false detection of the ACK and the NACK to ACK detection probability. The performance is measured by the required SNR at probability of the NACK to ACK detection equal to 0.1% or less. The probability of false detection of the ACK shall be 0.01 or less.

The probability of false detection of the ACK is defined as a conditional probability of erroneous detection of the ACK at particular bit position when input is only noise. Each false bit detection is counted as one error.

The NACK to ACK detection probability is the probability of detecting an ACK bit when a NACK bit was sent on particular bit position. Each NACK bit erroneously detected as ACK bit is counted as one error. Erroneously detected NACK bits in the definition do not contain the NACK bits which are mapped from DTX, i.e. NACK bits received when DTX is sent should not be considered.

The NACK to ACK detection requirement only applies to the PUCCH format 1 with 2 UCI bits. The UCI information only contains ACK/NACK information.

The 2bits UCI information is further defined with bitmap as [0 1].

Which specific test(s) are applicable to BS is based on the test applicability rules defined in clause 8.1.2.6.

### 8.3.8.1.2 Minimum Requirement

For BS type 1-O, the minimum requirement is in TS 38.104 [2], clause 11.3.1.9.

### 8.3.8.1.3 Test purpose

The test shall verify the receiver's ability not to falsely detect NACK bits as ACK bits under multipath fading propagation conditions for a given SNR.

### 8.3.8.1.4 Method of test

#### 8.3.8.1.4.1 Initial Conditions

Test environment: Normal; see annex B.2.

RF channels to be tested for single carrier: M; see clause 4.9.1

Direction to be tested: OTA REFSENS receiver target reference direction (see D.54 in table 4.6-1).

#### 8.3.8.1.4.2 Procedure

- 1) Place the BS with its manufacturer declared coordinate system reference point in the same place as calibrated point in the test system, as shown in annex E.3.
- 2) Align the manufacturer declared coordinate system orientation of the BS with the test system.
- 3) Set the BS in the declared direction to be tested.
- 4) Connect the BS tester generating the wanted signal, multipath fading simulators and AWGN generators to a test antenna via a combining network in OTA test setup, as shown in annex E.3. Each of the demodulation branch signals should be transmitted on one polarization of the test antenna(s).
- 5) The characteristics of the wanted signal shall be configured according to TS 38.211 [20], and according to additional test parameters listed in table 8.3.8.1.4.2-1.

**Table 8.3.8.1.4.2-1: Test parameters**

Parameter	Test
Number of information bits	2
Number of symbols	14
Intra-slot frequency hopping	N/A
Group and sequence hopping	neither
Hopping ID	0
Initial cyclic shift	0
First symbol	0
Index of orthogonal cover code ( <i>timeDomainOCC</i> )	0
Number of interlace	1
Interlace index	0 <sup>Note1</sup>
NOTE 1: RBs 0, 10, 20, ..., 100 are allocated for 15 KHz SCS and RBs 0, 5, 10, ..., 50 are allocated for 30 KHz SCS.	

- 6) The multipath fading emulators shall be configured according to the corresponding channel model defined in annex J.
- 7) Adjust the test signal mean power so the calibrated radiated SNR value at the BS receiver is as specified in clause 8.3.8.1.5.1 for BS type 1-O, and that the SNR at the BS receiver is not impacted by the noise floor.

The power level for the transmission may be set such that the AWGN level at the RIB is equal to the AWGN level in table 8.3.8.1.4.2-2.

**Table 8.3.8.1.4.2-2: AWGN power level at the BS input**

BS type	Subcarrier spacing (kHz)	Channel bandwidth (MHz)	AWGN power level
BS type 1-O (NOTE 2)	15	20	$-77.2 - \Delta_{\text{OTAREFSENS}}$ dBm / 19.08 MHz
	30	20	$-77.4 - \Delta_{\text{OTAREFSENS}}$ dBm / 18.36 MHz
NOTE 1: $\Delta_{\text{OTAREFSENS}}$ as declared in D.53 in table 4.6-1 and clause 7.1. NOTE 2: The AWGN power level contains an AWGN offset of 16dB by default. If needed for test purposes, the AWGN level can be reduced from the default by any value in the range 0dB to 16dB. Changing the AWGN level does not impact the validity of the test, as it reduces the effective base band SNR level.			

- 8) The signal generator sends random codeword from applicable codebook, in regular time periods. The following statistics are kept: the number of ACK bits detected in the idle periods and the number of NACK bits detected as ACK.

### 8.3.8.1.5 Test Requirement

#### 8.3.8.1.5.1 Test Requirement for BS type 1-O

The fraction of falsely detected ACK bits shall be less than 1 % and the fraction of NACK bits falsely detected as ACK shall be less than 0.1 % for the SNR listed in tables 8.3.8.1.5.1-1.

**Table 8.3.8.1.5.1-1: Required SNR for interlaced PUCCH format 1 with 15 kHz SCS, 20 MHz channel bandwidth**

Number of Tx antennas	Number of RX antennas	Cyclic Prefix	Propagation conditions and correlation matrix (Annex J)	SNR (dB)
1	2	Normal	TDLA30-10 Low	-13.2

**Table 8.3.8.1.5.1-2: Required SNR for interlaced PUCCH format 1 with 30 kHz SCS, 20 MHz channel bandwidth**

Number of Tx antennas	Number of RX antennas	Cyclic Prefix	Propagation conditions and correlation matrix (Annex J)	SNR (dB)
1	2	Normal	TDLA30-10 Low	-12.7

### 8.3.8.2 ACK missed detection

#### 8.3.8.2.1 Definition and applicability

The performance requirement of interlaced PUCCH format 1 for ACK missed detection is determined by the two parameters: probability of false detection of the ACK and the probability of detection of ACK. The performance is measured by the required SNR at probability of detection equal to 0.99. The probability of false detection of the ACK shall be 0.01 or less.

The probability of false detection of the ACK is defined as a conditional probability of erroneous detection of the ACK when input is only noise.

The probability of detection of ACK is defined as conditional probability of detection of the ACK when the signal is present.

The ACK missed detection requirement only applies to the PUCCH format 1 with 2 UCI bits. The UCI information only contains ACK/NACK information.

The 2bits UCI information is further defined with bitmap as [0 1].

Which specific test(s) are applicable to BS is based on the test applicability rules defined in clause 8.1.2.6.

#### 8.3.8.2.2 Minimum Requirement

For BS type 1-O, the minimum requirement is in TS 38.104 [2], clause 11.3.1.9.

#### 8.3.8.2.3 Test purpose

The test shall verify the receiver's ability to detect ACK bits under multipath fading propagation conditions for a given SNR.

#### 8.3.8.2.4 Method of test

##### 8.3.8.2.4.1 Initial Conditions

Test environment: Normal; see annex B.2.

RF channels to be tested for single carrier: M; see clause 4.9.1

Direction to be tested: OTA REFSENS receiver target reference direction (see D.54 in table 4.6-1).

##### 8.3.8.2.4.2 Procedure

- 1) Place the BS with its manufacturer declared coordinate system reference point in the same place as calibrated point in the test system, as shown in annex E.3.
- 2) Align the manufacturer declared coordinate system orientation of the BS with the test system.
- 3) Set the BS in the declared direction to be tested.
- 4) Connect the BS tester generating the wanted signal, multipath fading simulators and AWGN generators to a test antenna via a combining network in OTA test setup, as shown in annex E.3. Each of the demodulation branch signals should be transmitted on one polarization of the test antenna(s).
- 5) The characteristics of the wanted signal shall be configured according to TS 38.211 [20], and according to additional test parameters listed in table 8.3.8.2.4.2-1.



**Table 8.3.8.2.4.2-1: Test Parameters**

Parameter	Test
Number of information bits	2
Number of symbols	14
Intra-slot frequency hopping	N/A
Group and sequence hopping	neither
Hopping ID	0
Initial cyclic shift	0
First symbol	0
Index of orthogonal cover code ( <i>timeDomainOCC</i> )	0
Number of interlace	1
Interlace index	0 <sup>Note1</sup>
NOTE 1: RBs 0, 10, 20, ..., 100 are allocated for 15 KHz SCS and RBs 0, 5, 10, ..., 50 are allocated for 30 KHz SCS.	

- 6) The multipath fading emulators shall be configured according to the corresponding channel model defined in annex J.2.
- 7) Adjust the test signal mean power so the calibrated radiated SNR value at the BS receiver is as specified in clause 8.3.8.2.5.1 for BS type 1-O, and that the SNR at the BS receiver is not impacted by the noise floor.

The power level for the transmission may be set such that the AWGN level at the RIB is equal to the AWGN level in table 8.3.8.2.4.2-2.

**Table 8.3.8.2.4.2-2: AWGN power level at the BS input**

BS type	Subcarrier spacing (kHz)	Channel bandwidth (MHz)	AWGN power level
BS type 1-O (NOTE 2)	15	20	$-77.2 - \Delta_{\text{OTAREFSENS}}$ dBm / 19.08 MHz
	30	20	$-77.4 - \Delta_{\text{OTAREFSENS}}$ dBm / 18.36 MHz
NOTE 1: $\Delta_{\text{OTAREFSENS}}$ as declared in D.53 in table 4.6-1 and clause 7.1.			
NOTE 2: The AWGN power level contains an AWGN offset of 16dB by default. If needed for test purposes, the AWGN level can be reduced from the default by any value in the range 0dB to 16dB. Changing the AWGN level does not impact the validity of the test, as it reduces the effective base band SNR level.			

- 8) The signal generator sends random codewords from applicable codebook, in regular time periods. The following statistics are kept: the number of ACK bits falsely detected in the idle periods and the number of missed ACK bits. Each falsely detected ACK bit in the idle periods is accounted as one error for the statistics of false ACK detection, and each missed ACK bit is accounted as one error for the statistics of missed ACK detection.

Note that the procedure described in this clause for ACK missed detection has the same condition as that described in clause 8.3.8.1.4.2 for NACK to ACK detection. Both statistics are measured in the same testing.

### 8.3.8.2.5 Test Requirement

#### 8.3.8.2.5.1 Test Requirement for BS type 1-O

The fraction of falsely detected ACK bits shall be less than 1% and the fraction of correctly detected ACK bits shall be larger than 99% for the SNR listed in tables 8.3.8.2.5-1.

**Table 8.3.8.2.5.1-1: Required SNR for interlaced PUCCH format 1 with 15 kHz SCS, 20 MHz channel bandwidth**

Number of Tx antennas	Number of RX antennas	Cyclic Prefix	Propagation conditions and correlation matrix (Annex J)	SNR (dB)
1	2	Normal	TDLA30-10 Low	-13.8

**Table 8.3.8.2.5.1-2: Required SNR for interlaced PUCCH format 1 with 30 kHz SCS, 20 MHz channel bandwidth**

Number of Tx antennas	Number of RX antennas	Cyclic Prefix	Propagation conditions and correlation matrix (Annex J)	SNR (dB)
1	2	Normal	TDLA30-10 Low	-13.5

## 8.3.9 Performance requirements for interlaced PUCCH format 2

### 8.3.9.1 Definition and applicability

The performance is measured by the required SNR at UCI block error probability not exceeding.

The UCI block error probability is defined as the probability of incorrectly decoding the UCI information when the UCI information is sent. The UCI information does not contain CSI part 2.

The UCI block error probability performance requirement only applies to the PUCCH format 2 with 22 UCI bits.

The 22bits UCI information case is assumed random information bit selection.

Which specific test(s) are applicable to BS is based on the test applicability rules defines in clause 8.1.2.6.

### 8.3.9.2 Minimum Requirement

For *BS type I-O*, the minimum requirement is in TS 38.104 [2] clause 11.3.1.10.

### 8.3.9.3 Test Purpose

The test shall verify the receiver's ability to detect UCI under multipath fading propagation conditions for a given SNR.

### 8.3.9.4 Method of test

#### 8.3.9.4.1 Initial conditions

Test environment: Normal, see clause B.2.

RF channels to be tested for single carrier;M; see clause 4.9.1

Direction to be tested: OTA REFSSENS *receiver target reference direction* (see D.54 in table.4.6-1).

#### 8.3.9.4.2 Procedure

- 1) Place the BS with its manufacturer declared coordinate system reference point in the same place as calibrated point in the test system, as shown in annex E.3.
- 2) Align the manufacturer declared coordinate system orientation of the BS with the test system.
- 3) Set the BS in the declared direction to be tested.
- 4) Connect the BS tester generating the wanted signal, multipath fading simulators and AWGN generators to a test antenna via a combining network in OTA test setup, as shown in annex E.3. Each of the demodulation branch signals should be transmitted one polarization of the test antenna(s).
- 5) The characteristics of the wanted signal shall be configured according to TS 38.211 [20], and according to additional test parameters listed in table 8.3.9.4.2-1.

**Table 8.3.9.4.2-1: Test parameters**

Parameter	Value
Modulation order	QSPK
Intra-slot frequency hopping	N/A
Number of symbols	1
The number of UCI information bits	22
First symbol	13
DM-RS sequence generation	$N_{ID}^0=0$
Number of interlaces	1
Interlace index	0(note 1)
OCC-length-r16	Not configured
NOTE 1: RBs 0,10,20,...,100 are allocated for 15 KHz SCS and RBs 0, 5, 10,...,50 are allocated for 30 KHz SCS	

- 6) The multipath fading emulators shall be configured according to the corresponding channel model defined in annex J.
- 7) Adjust the test signal mean power so the calibrated radiated SNR value at the BS receiver is as specified in clause 8.3.9.5 for *BS type 1-O*, and that the SNR at the BS receiver is not impacted by the noise floor.

The power level for the transmission may be set such that the AWGN level at the RIB is equal to the AWGN level in table 8.3.9.4.2-2.

**Table 8.3.9.4.2-2: AWGN power level at the BS input**

BS type	Sub-carrier spacing (kHz)	Channel bandwidth (MHz)	AWGN power level
BS type 1-O	15 kHz	20	$-77.2 - \Delta_{OTAREFSENS}$ dBm / 19.08 MHz
BS type 1-O	30 kHz	20	$-77.4 - \Delta_{OTAREFSENS}$ dBm / 18.36 MHz
NOTE 1: $\Delta_{OTAREFSENS}$ as declared in D.53 in table 4.6-1 and clause 7.1.			
NOTE 2: The AWGN power level contains an AWGN offset of 16dB by default. If needed for test purposes, the AWGN level can be reduced from the default by any value in the range 0dB to 16dB. Changing the AWGN level does not impact the validity of the test, as it reduces the effective base band SNR level.			

- 8) The signal generator sends a test pattern with pattern outlined in figure 8.3.9.4.2-1. The following statistics are kept: he number of incorrectly decoded UCI.



**Figure 8.3.9.4.2-1: Test signal pattern for interlaced PUCCH format 2 demodulation tests**

**8.3.9.5 Test requirement**

The fraction of incorrectly decoded UCI is shall be less than 1% for the SNR listed in table 8.3.9.5-1 and table 8.3.9.5-2.

**Table 8.3.9.5-1: Required SNR for interlaced PUCCH format 2 with 15 kHz SCS, 20 MHz channel bandwidth**

Number of TX antennas	Number of demodulation branches	Cyclic Prefix	Propagation conditions and correlation matrix (Annex J)	SNR(dB)
1	2	Normal	TDLA30-10 Low	4.1

**Table 8.3.9.5-2: Required SNR for interlaced PUCCH format 2 with 30 kHz SCS, 20 MHz channel bandwidth**

Number of TX antennas	Number of demodulation branches	Cyclic Prefix	Propagation conditions and correlation matrix (Annex J)	SNR(dB)
1	2	Normal	TDLA30-10 Low	4.5

## 8.3.10 Performance requirements for interlaced PUCCH format 3

### 8.3.10.1 Definition and applicability

The performance requirement of interlaced PUCCH format 3 for ACK missed detection is determined by the two parameters: probability of false detection of the ACK and the probability of detection of ACK on the wanted signal. The performance is measured by the required SNR at probability of detection equal to 0.99. The probability of false detection of the ACK shall be 0.01 or less.

The probability of false detection of the ACK is defined as a probability of erroneous detection of the ACK when input is only noise.

The probability of detection of ACK is defined as probability of detection of the ACK when the signal is present.

The ACK missed detection requirement only applies to the PUCCH format 3 with 4 UCI bits. The UCI information only contains ACK information.

The 4bits UCI information case is further defined with the bitmap as [1 1 1 1].

Which specific test(s) are applicable to BS is based on the test applicability rules defines in clause 8.1.2.6.

### 8.3.10.2 Minimum Requirement

For *BS type I-O*, the minimum requirement is in TS 38.104 [2] clause 11.3.1.11

### 8.3.10.3 Test Purpose

The test shall verify the receiver's ability to detect ACK bits under multipath fading propagation conditions for a given SNR.

### 8.3.10.4 Method of test

#### 8.3.10.4.1 Initial conditions

Test environment: Normal, see clause B.2.

RF channels to be tested for single carrier;M; see clause 4.9.1

Direction to be tested: OTA REFSSENS *receiver target reference direction* (see D.54 in table.4.6-1).

#### 8.3.10.4.2 Procedure

- 1) Place the BS with its manufacturer declared coordinate system reference point in the same place as calibrated point in the test system, as shown in annex E.3.
- 2) Align the manufacturer declared coordinate system orientation of the BS with the test system.
- 3) Set the BS in the declared direction to be tested.
- 4) Connect the BS tester generating the wanted signal, multipath fading simulators and AWGN generators to a test antenna via a combining network in OTA test setup, as shown in annex E.3. Each of the demodulation branch signals should be transmitted one polarization of the test antenna(s).

- 5) The characteristics of the wanted signal shall be configured according to TS 38.211 [20], and according to additional test parameters listed in table 8.3.10.4.2-1.

**Table 8.3.10.4.2-1: Test parameters**

Parameter	Value
Modulation order	QPSK
Intra-slot frequency hopping	N/A
Group and sequence hopping	Neither
Hopping ID	0
Number of symbols	4
The number of UCI information bits	4
Index of OCC	Not configured
Length of OCC	Not configured
Cyclic shift index for DMRS	0
Number of Interlace	1
Interlace index	0(note 1)
NOTE 1: RBs 0,10,20,...,90 are allocated for 15 KHz SCS and RBs 0,5,10,...,45 are allocated for 30 KHz SCS	

- 6) The multipath fading emulators shall be configured according to the corresponding channel model defined in annex J.
- 7) Adjust the test signal mean power so the calibrated radiated SNR value at the BS receiver is as specified in clause 8.3.10.5 for *BS type 1-O*, and that the SNR at the BS receiver is not impacted by the noise floor.

The power level for the transmission may be set such that the AWGN level at the RIB is equal to the AWGN level in table 8.3.10.4.2-2.

**Table 8.3.10.4.2-2: AWGN power level at the BS input**

BS type	Sub-carrier spacing (kHz)	Channel bandwidth (MHz)	AWGN power level
BS type 1-O	15 kHz	20	-77.2 - $\Delta_{OTAREFSENS}$ dBm / 19.08 MHz
BS type 1-O	30 kHz	20	-77.4 - $\Delta_{OTAREFSENS}$ dBm / 18.36 MHz
NOTE 1: $\Delta_{OTAREFSENS}$ as declared in D.53 in table 4.6-1 and clause 7.1.			
NOTE 2: The AWGN power level contains an AWGN offset of 16dB by default. If needed for test purposes, the AWGN level can be reduced from the default by any value in the range 0dB to 16dB. Changing the AWGN level does not impact the validity of the test, as it reduces the effective base band SNR level.			

- 8) The signal generator sends a test pattern with pattern outlined in figure 8.3.10.4.2-1. The following statistics are kept: the number of ACK bits detected in the idle periods and the number of missed ACKs.



**Figure 8.3.10.4.2-1: Test signal pattern for interlaced PUCCH format 3 demodulation tests**

### 8.3.10.5 Test requirement

The fraction of falsely detected ACKs shall be less than 1% and the fraction of correctly detected ACKs shall be larger than 99% for the SNR listed in table 8.3.10.5.1-1 and table 8.3.10.5.1-2.

**Table 8.3.10.5.1-1: Required SNR for interlaced PUCCH format 3 with 15 kHz SCS, 20 MHz channel bandwidth**

Number of TX antennas	Number of demodulation branches	Cyclic Prefix	Propagation conditions and correlation matrix (Annex J)	Additional DM-RS configuration	SNR(dB)
1	2	Normal	TDLA30-10 Low	No additional DM-RS	-5.4

**Table 8.3.10.5.1-2: Required SNR for interlaced PUCCH format 3 with 30 kHz SCS, 20 MHz channel bandwidth**

Number of TX antennas	Number of demodulation branches	Cyclic Prefix	Propagation conditions and correlation matrix (Annex J)	Additional DM-RS configuration	SNR(dB)
1	2	Normal	TDLA30-10 Low	No additional DM-RS	-4.8

## 8.3.11 Performance requirements for PUCCH sub-slot based repetition format 0

### 8.3.11.1 Definition and applicability

The performance requirement of PUCCH sub-slot based repetition format 0 for ACK missed detection is determined by the two parameters: probability of false detection of the ACK and the probability of detection of ACK. The performance is measured by the required SNR at probability of detection equal to 0.99. The probability of false detection of the ACK shall be 0.01 or less.

The probability of false detection of the ACK is defined as a conditional probability of erroneous detection of the ACK when input is only noise.

The probability of detection of ACK is defined as conditional probability of detection of the ACK when the signal is present.

The ACK missed detection probability performance requirement only apply to PUCCH format 0 with 1 UCI bit. The UCI information only contain ACK information.

The 1bit UCI information is further defined with the bitmap as [1].

The transient period as specified in TS 38.101-1 [24] clause 6.3.3.1 and TS 38.101-2 [25] clause 6.3.3.1 is not taken into account for performance requirement testing, where the RB hopping is symmetric to the CC center, i.e. intra-slot frequency hopping is enabled.

Which specific test(s) are applicable to BS is based on the test applicability rules defined in clause 8.1.2.

### 8.3.11.2 Minimum Requirement

For *BS type I-O*, the minimum requirements are in TS 38.104 [2] clause 11.3.1.10.

### 8.3.11.3 Test purpose

The test shall verify the receiver's ability to detect ACK under multipath fading propagation conditions for a given SNR.

### 8.3.11.4 Method of test

#### 8.3.11.4.1 Initial conditions

Test environment: Normal, see annex B.2.

RF channels to be tested: single carrier M; see clause 4.9.1.

Direction to be tested: OTA REFSENS *receiver target reference direction* (see D.54 in table 4.6-1).

#### 8.3.11.4.2 Procedure

- 1) Place the BS with its manufacturer declared coordinate system reference point in the same place as calibrated point in the test system, as shown in annex E.3.
- 2) Align the manufacturer declared coordinate system orientation of the BS with the test system.
- 3) Set the BS in the declared direction to be tested.
- 4) Connect the BS tester generating the wanted signal, multipath fading simulators and AWGN generators to a test antenna via a combining network in OTA test setup, as shown in annex E.3. Each of the demodulation branch signals should be transmitted on one polarization of the test antenna(s).
- 5) The characteristics of the wanted signal shall be configured according to TS 38.211 [20] and according to additional test parameters listed in table 8.3.11.4.2-1.

**Table 8.3.11.4.2-1: Test parameters**

Parameter	Test
Number of UCI information bits	1
Number of PRBs	1
Number of PUCCH symbols ( <i>nrofSymbols</i> )	2
Number of PUCCH sub-slot based repetitions ( <i>nrofSlots</i> )	2
Number of Sub-slot symbols ( <i>subslotLengthForPUCCH-r16</i> )	7
First symbol of sub-slot ( <i>startingSymbolIndex</i> )	5
First PRB prior to frequency hopping	0
First PRB after frequency hopping	The largest PRB index – (Number of PRBs – 1)
Intra-slot frequency hopping	disabled
Inter-slot frequency hopping	enabled
Group and sequence hopping	neither
Hopping ID	0
Initial cyclic shift	0

- 6) The multipath fading emulators shall be configured according to the corresponding channel model defined in annex J.2.
- 7) Adjust the test signal mean power so the calibrated radiated SNR value at the BS receiver is as specified in clause 8.3.11.5.1 for *BS type I-O*, and that the SNR at the BS receiver is not impacted by the noise floor.

The power level for the transmission may be set such that the AWGN level at the RIB is equal to the AWGN level quoted in table 8.3.11.4.2-2.

**Table 8.3.11.4.2-2: AWGN power level at the BS input**

BS type	Sub-carrier spacing (kHz)	Channel bandwidth (MHz)	AWGN power level
BS type 1-O (Note 2)	30	10	-80.6 - $\Delta_{OTAREFSENS}$ dBm / 8.64 MHz
NOTE 1: $\Delta_{OTAREFSENS}$ as declared in D.53 in table 4.6-1 and clause 7.1.			
NOTE 2: The AWGN power level contains an AWGN offset of 16dB by default. If needed for test purposes, the AWGN level can be reduced from the default by any value in the range 0dB to 16dB. Changing the AWGN level does not impact the validity of the test, as it reduces the effective base band SNR level.			

8) The signal generator sends a test pattern with the pattern outlined in figure 8.3.11.4.2-1. The following statistics are kept: the number of ACKs detected in the idle periods and the number of missed ACKs.



**Figure 8.3.11.4.2-1: Test signal pattern for PUCCH sub-slot based repetition format 0 demodulation tests**

### 8.3.11.5 Test Requirement

#### 8.3.11.5.1 Test requirement for BS type 1-O

The fraction of falsely detected ACKs shall be less than 1% and the fraction of correctly detected ACKs shall be larger than 99% for the SNR listed in table 8.3.11.5.1-1.

**Table 8.3.11.5.1-1: Test requirements for PUCCH sub-slot repetition format 0 and 30 kHz SCS, 10 MHz channel bandwidth**

Number of TX antennas	Number of demodulation branches	Cyclic Prefix	Propagation conditions and correlation matrix (annex J)	SNR (dB)
1	2	Normal	TDLC300-100 Low	[2.1]

### 8.3.12 Performance requirements PUCCH format 1 with DM-RS bundling

#### 8.3.12.1 NACK to ACK detection

##### 8.3.12.1.1 Definition and applicability

The performance requirement of PUCCH format 1 with DM-RS bundling for NACK to ACK detection is determined by the two parameters: probability of false detection of the ACK and the NACK to ACK detection probability. The performance is measured by the required SNR at probability of the NACK to ACK detection equal to 0.1 % or less. The probability of false detection of the ACK shall be 1 % or less.

The probability of false detection of the ACK is defined as a conditional probability of erroneous detection of the ACK at particular bit position when input is only noise. Each false bit detection is counted as one error.

The NACK to ACK detection probability is the probability of detecting an ACK bit when an NACK bit was sent on particular bit position. Each NACK bit erroneously detected as ACK bit is counted as one error. Erroneously detected NACK bits in the definition do not contain the NACK bits which are mapped from DTX, i.e. NACK bits received when DTX is sent should not be considered.

Which specific test(s) are applicable to BS is based on the test applicability rules defined in clause 8.1.2.2.



### 8.3.12.1.2 Minimum Requirement

For BS type 1-O, the minimum requirement is in TS 38.104 [2], clause 11.3.1.8.

For BS type 2-O, the minimum requirement is in TS 38.104 [2], clause 11.3.2.7.

### 8.3.12.1.3 Test purpose

The test shall verify the receiver's ability not to falsely detect NACK bits as ACK bits under multipath fading propagation conditions for a given SNR.

### 8.3.12.1.4 Method of test

#### 8.3.12.1.4.1 Initial conditions

Test environment: Normal; see annex B.2.

RF channels to be tested: for single carrier: M; see clause 4.9.1.

Direction to be tested: OTA REFSSENS receiver target reference direction (see D.54 in table 4.6-1).

#### 8.3.12.1.4.2 Procedure

- 1) Place the BS with its manufacturer declared coordinate system reference point in the same place as calibrated point in the test system, as shown in annex E.3.
- 2) Align the manufacturer declared coordinate system orientation of the BS with the test system.
- 3) Set the BS in the declared direction to be tested.
- 4) Connect the BS tester generating the wanted signal, multipath fading simulators and AWGN generators to a test antenna via a combining network in OTA test setup, as shown in annex E.3. Each of the demodulation branch signals should be transmitted on one polarization of the test antenna(s).
- 5) The characteristics of the wanted signal shall be configured according to TS 38.211 [20], and according to additional test parameters listed in table 8.3.12.1.4.2-1.

**Table 8.3.12.1.4.2-1: Test parameters for PUCCH format 1 with DM-RS bundling**

Parameter	Test 1 [TDD]	Test 2 [FDD]
Example TDD UL-DL pattern (Note1)	15/30 kHz SCS: 7D1S2U, S=6D:4G:4U 60/120 kHz SCS: DDSUU, S=10D:2G:2U or DSUUU, S=10D:2G:2U	
Number of information bits	2	2
Number of PRBs	1	1
Number of symbols	14	14
Intra-slot frequency hopping	disabled	disabled
Inter-slot frequency hopping	disabled	disabled
Hopping ID	0	0
Initial cyclic shift	0	0
First symbol	0	0
Index of orthogonal cover code ( <i>timeDomainOCC</i> )	0	0
Number of slots for PUCCH repetition	2	8
PUCCH-TimeDomainWindowLength	2	8
Note 1:	The same TDD requirements are applicable to different UL-DL patterns with more than one consecutive UL slots when both <i>pucch-TimeDomainWindowLength</i> and PUCCH aggregation factor are configured as 2 slots. The UL (re)transmission of PUCCH is only scheduled for the actual TDW including 2 consecutive UL slots.	

- 6) The multipath fading emulators shall be configured according to the corresponding channel model defined in annex J.
- 7) Adjust the test signal mean power so the calibrated radiated SNR value at the BS receiver is as specified in clause 8.3.12.1.5.1 and 8.3.12.1.5.2 for BS type 1-O and BS type 2-O respectively, and that the SNR at the BS receiver is not impacted by the noise floor.

The power level for the transmission may be set such that the AWGN level at the RIB is equal to the AWGN level in table 8.3.12.1.4.2-2

**Table 8.3.12.1.4.2-2: AWGN power level at the BS input**

BS type	Subcarrier spacing (kHz)	Channel bandwidth (MHz)	AWGN power level
BS type 1-O (Note 4)	15 kHz	5	$-83.5 - \Delta_{\text{OTAREFSENS}}$ dBm / 4.5 MHz
	30 kHz	10	$-80.6 - \Delta_{\text{OTAREFSENS}}$ dBm / 8.64 MHz
BS type 2-O (Note 5)	60 kHz	50	$\text{EIS}_{\text{REFSENS\_50M}} + \Delta_{\text{FR2\_REFSENS}} + 15$ dBm / 47.52 MHz
	120 kHz	50	$\text{EIS}_{\text{REFSENS\_50M}} + \Delta_{\text{FR2\_REFSENS}} + 15$ dBm / 46.08 MHz
NOTE 1: $\Delta_{\text{OTAREFSENS}}$ as declared in D.53 in table 4.6-1 and clause 7.1. NOTE 2: $\Delta_{\text{FR2\_REFSENS}} = -3$ dB as described in clause 7.1, since the OTA REFSENS reference direction (as declared in D.54 in table 4.6-1) is used for testing. NOTE 3: $\text{EIS}_{\text{REFSENS\_50M}}$ as declared in D.28 in table 4.6-1. NOTE 4: The AWGN power level contains an AWGN offset of 16dB by default. If needed for test purposes, the AWGN level can be reduced from the default by any value in the range 0dB to 16dB. Changing the AWGN level does not impact the validity of the test, as it reduces the effective base band SNR level. NOTE 5: The AWGN power level contains an AWGN offset of 15dB by default. If needed for test purposes, the AWGN level can be reduced from the default by any value in the range 0dB to 15dB. Changing the AWGN level does not impact the validity of the test, as it reduces the effective base band SNR level.			

- 8) The signal generator sends random codewords from applicable codebook, in regular time periods that conform with the required *actual Time Domain Window* (aTDW) needed by the tests (see subclause 8.2.14xx). The following statistics are kept: the number of ACK bits falsely detected in the idle periods and the number of missed ACK bits. Each falsely detected ACK bit in the idle periods is accounted as one error for the statistics of false ACK detection, and each missed ACK bit is accounted as one error for the statistics of missed ACK detection.

Note that the procedure described in this clause for ACK missed detection has the same condition as that described in clause 8.3.12.1.4.2 for NACK to ACK detection. Both statistics are measured in the same testing.

### 8.3.12.1.5 Test Requirement

#### 8.3.12.1.5.1 Test Requirement for BS type 1-O

The fraction of falsely detected ACK bits shall be less than 1 % and the fraction of NACK bits falsely detected as ACK shall be less than 0.1 % for the SNR listed in table 8.3.12.1.5.1-1 and table 8.3.12.1.5.1-2.

**Table 8.3.12.1.5.1-1: Minimum requirements for PUCCH format 1 with DM-RS bundling with 15 kHz SCS**

Test Number	Number of TX antennas	Number of demodulation branches	Cyclic Prefix	Propagation conditions and correlation matrix (annex J)	Channel bandwidth / SNR (dB)
					5 MHz
1	1	2	Normal	TDLA30-10	-2.4
2	1	2	Normal	TDLA30-10	-8.5

**Table 8.3.12.1.5.1-2: Minimum requirements for PUCCH format 1 with DM-RS bundling with 30 kHz SCS**

Test Number	Number of TX antennas	Number of demodulation branches	Cyclic Prefix	Propagation conditions and correlation matrix (annex J)	Channel bandwidth / SNR (dB)
					10 MHz
1	1	2	Normal	TDLA30-10	-2.4
2	1	2	Normal	TDLA30-10	-8.1

### 8.3.12.1.5.2 Test Requirement for BS type 2-O

The fraction of falsely detected ACK bits shall be less than 1% and the fraction of correctly detected ACK bits shall be larger than 99% for the SNR listed in tables 8.3.12.1.5.2-1 and table 8.3.12.1.5.2-2.

**Table 8.3.12.1.5.2-1: Minimum requirements for PUCCH format 1 with DM-RS bundling with 60 kHz SCS**

Test Number	Number of TX antennas	Number of demodulation branches	Cyclic Prefix	Propagation conditions and correlation matrix (annex G)	Channel bandwidth / SNR (dB)
					50 MHz
1	1	2	Normal	TDLA30-10	-2.7

**Table 8.3.12.1.5.2-2: Minimum requirements for PUCCH format 1 with DM-RS bundling with 120 kHz SCS**

Test Number	Number of TX antennas	Number of demodulation branches	Cyclic Prefix	Propagation conditions and correlation matrix (annex G)	Channel bandwidth / SNR (dB)
					50 MHz
1	1	2	Normal	TDLA30-75	-2.6

## 8.3.12.2 ACK missed detection

### 8.3.12.2.1 Definition and applicability

The performance requirement of PUCCH format 1 for ACK missed detection is determined by the two parameters: probability of false detection of the ACK and the probability of detection of ACK. The performance is measured by the required SNR at probability of detection equal to 0.99. The probability of false detection of the ACK shall be 0.01 or less.

The probability of false detection of the ACK is defined as a conditional probability of erroneous detection of the ACK when input is only noise.

The probability of detection of ACK is defined as conditional probability of detection of the ACK when the signal is present.

Which specific test(s) are applicable to BS is based on the test applicability rules defined in clause 8.1.2.

#### 8.3.12.2.2 Minimum Requirement

For BS type 1-O, the minimum requirement is in TS 38.104 [2], clause 11.3.1.8.

For BS type 2-O, the minimum requirement is in TS 38.104 [2], clause 11.3.2.7.

#### 8.3.12.2.3 Test purpose

The test shall verify the receiver's ability to detect ACK bits under multipath fading propagation conditions for a given SNR.

#### 8.3.12.2.4 Method of test

##### 8.3.12.2.4.1 Initial conditions

Test environment: Normal; see annex B.2.

RF channels to be tested: for single carrier: M; see clause 4.9.1.

Direction to be tested: OTA REFSENS receiver target reference direction (see D.54 in table 4.6-1).

##### 8.3.12.2.4.2 Procedure

- 1) Place the BS with its manufacturer declared coordinate system reference point in the same place as calibrated point in the test system, as shown in annex E.3.
- 2) Align the manufacturer declared coordinate system orientation of the BS with the test system.
- 3) Set the BS in the declared direction to be tested.
- 4) Connect the BS tester generating the wanted signal, multipath fading simulators and AWGN generators to a test antenna via a combining network in OTA test setup, as shown in annex E.3. Each of the demodulation branch signals should be transmitted on one polarization of the test antenna(s).
- 5) The characteristics of the wanted signal shall be configured according to TS 38.211 [20], and according to additional test parameters listed in table 8.3.12.2.4.2-1.

**Table 8.3.12.2.4.2-1: Test parameters for PUCCH format 1 with DM-RS bundling**

Parameter	Test 1 [TDD]	Test 2 [FDD]
Example TDD UL-DL pattern (Note1)	15/30 kHz SCS: 7D1S2U, S=6D:4G:4U 60/120 kHz SCS: DDSUU, S=10D:2G:2U or DSUUU, S=10D:2G:2U	
Number of information bits	2	2
Number of PRBs	1	1
Number of symbols	14	14
Intra-slot frequency hopping	disabled	disabled
Inter-slot frequency hopping	disabled	disabled
Hopping ID	0	0
Initial cyclic shift	0	0
First symbol	0	0
Index of orthogonal cover code ( <i>timeDomainOCC</i> )	0	0
Number of slots for PUCCH repetition	2	8
PUCCH-TimeDomainWindowLength	2	8
Note 1:	The same TDD requirements are applicable to different UL-DL patterns with more than one consecutive UL slots when both <i>pucch-TimeDomainWindowLength</i> and PUCCH aggregation factor are configured as 2 slots. The UL (re)transmission of PUCCH is only scheduled for the actual TDW including 2 consecutive UL slots.	

- 6) The multipath fading emulators shall be configured according to the corresponding channel model defined in annex J.2.
- 7) Adjust the test signal mean power so the calibrated radiated SNR value at the BS receiver is as specified in clause 8.3.12.2.5-1 and 8.3.12.2.5-2 for BS type 1-O and BS type 2-O respectively, and that the SNR at the BS receiver is not impacted by the noise floor.

The power level for the transmission may be set such that the AWGN level at the RIB is equal to the AWGN level in table 8.3.12.2.4.2-2.

**Table 8.3.12.2.4.2-2: AWGN power level at the BS input**

BS type	Subcarrier spacing (kHz)	Channel bandwidth (MHz)	AWGN power level
BS type 1-O (Note 4)	15 kHz	5	$-83.5 - \Delta_{\text{OTAREFSSENS}}$ dBm / 4.5 MHz
	30 kHz	10	$-80.6 - \Delta_{\text{OTAREFSSENS}}$ dBm / 8.64 MHz
BS type 2-O (Note 5)	60 kHz	50	$\text{EIS}_{\text{REFSENS}_50\text{M}} + \Delta_{\text{FR2\_REFSENS}} + 15$ dBm / 47.52 MHz
	120 kHz	50	$\text{EIS}_{\text{REFSENS}_50\text{M}} + \Delta_{\text{FR2\_REFSENS}} + 15$ dBm / 46.08 MHz
NOTE 1: $\Delta_{\text{OTAREFSSENS}}$ as declared in D.53 in table 4.6-1 and clause 7.1.			
NOTE 2: $\Delta_{\text{FR2\_REFSENS}} = -3$ dB as described in clause 7.1, since the OTA REFSENS reference direction (as declared in D.54 in table 4.6-1) is used for testing.			
NOTE 3: $\text{EIS}_{\text{REFSENS}_50\text{M}}$ as declared in D.28 in table 4.6-1.			
NOTE 4: The AWGN power level contains an AWGN offset of 16dB by default. If needed for test purposes, the AWGN level can be reduced from the default by any value in the range 0dB to 16dB. Changing the AWGN level does not impact the validity of the test, as it reduces the effective base band SNR level.			
NOTE 5: The AWGN power level contains an AWGN offset of 15dB by default. If needed for test purposes, the AWGN level can be reduced from the default by any value in the range 0dB to 15dB. Changing the AWGN level does not impact the validity of the test, as it reduces the effective base band SNR level.			

- 8) The signal generator sends random codewords from applicable codebook, in regular time periods. The following statistics are kept: the number of ACK bits falsely detected in the idle periods and the number of missed ACK bits. Each falsely detected ACK bit in the idle periods is accounted as one error for the statistics of false ACK detection, and each missed ACK bit is accounted as one error for the statistics of missed ACK detection.

Note that the procedure described in this clause for ACK missed detection has the same condition as that described in clause 8.3.12.1.4.2 for NACK to ACK detection. Both statistics are measured in the same testing.

### 8.3.12.2.5 Test Requirement

#### 8.3.12.2.5.1 Test Requirement for BS type 1-O

The fraction of falsely detected ACK bits shall be less than 1 % and the fraction of correctly detected ACK bits shall be larger than 99 % for the SNR listed in table 8.3.12.2.5.1-1 and table 8.3.12.2.5.1-2.

**Table 8.3.12.2.5.1-1: Minimum requirements for PUCCH format 1 with DM-RS bundling with 15 kHz SCS**

Test Number	Number of TX antennas	Number of demodulation branches	Cyclic Prefix	Propagation conditions and correlation matrix (annex J)	Channel bandwidth / SNR (dB)
					5 MHz
1	1	2	Normal	TDLA30-10	-3.3
2	1	2	Normal	TDLA30-10	-8.3

**Table 8.3.12.2.5.1-2: Minimum requirements for PUCCH format 1 with DM-RS bundling with 30 kHz SCS**

Test Number	Number of TX antennas	Number of demodulation branches	Cyclic Prefix	Propagation conditions and correlation matrix (annex J)	Channel bandwidth / SNR (dB)
					10 MHz
1	1	2	Normal	TDLA30-10	-3.2
2	1	2	Normal	TDLA30-10	-7.9

#### 8.3.12.2.5.2 Test Requirement for BS type 2-O

The fraction of falsely detected ACK bits shall be less than 1 % and the fraction of correctly detected ACK bits shall be larger than 99 % for the SNR listed in table 8.3.12.2.5.2-1 and table 8.3.12.2.5.2-2.

**Table 8.3.12.2.5.2-1: Minimum requirements for PUCCH format 1 with DM-RS bundling with 60 kHz SCS**

Test Number	Number of TX antennas	Number of demodulation branches	Cyclic Prefix	Propagation conditions and correlation matrix (annex J)	Channel bandwidth / SNR (dB)
					50 MHz
1	1	2	Normal	TDLA30-10	-4.2

**Table 8.3.12.2.5.2-2: Minimum requirements for PUCCH format 1 with DM-RS bundling with 120 kHz SCS**

Test Number	Number of TX antennas	Number of demodulation branches	Cyclic Prefix	Propagation conditions and correlation matrix (annex J)	Channel bandwidth / SNR (dB)
					50 MHz
1	1	2	Normal	TDLA30-75	-4.3

## 8.3.13 Performance requirements for PUCCH format 3 with DM-RS bundling

### 8.3.13.1 Definition and applicability

The performance is measured by the required SNR at UCI block error probability not exceeding 1%.

The UCI block error probability is defined as the conditional probability of incorrectly decoding the UCI information when the UCI information is sent. The UCI information does not contain CSI part 2.

Which specific test(s) are applicable to BS is based on the test applicability rules defined in clause 8.1.2.2.

### 8.3.13.2 Minimum requirement

For BS type 1-O, the minimum requirement is in TS 38.104 [2], clause 11.3.1.9.

For BS type 2-O, the minimum requirement is in TS 38.104 [2], clause 11.3.2.10.

### 8.3.13.3 Test purpose

The test shall verify the receiver's ability to detect UCI under multipath fading propagation conditions for a given SNR.

### 8.3.13.4 Method of test

#### 8.3.13.4.1 Initial conditions

Test environment: Normal; see annex B.2.

RF channels to be tested for single carrier: M; see clause 4.9.1

Direction to be tested: OTA REFSENS *receiver target reference direction* (see D.54 in table.4.6-1).

#### 8.3.13.4.2 Procedure

- 1) Place the BS with its manufacturer declared coordinate system reference point in the same place as calibrated point in the test system, as shown in annex E.3.
- 2) Align the manufacturer declared coordinate system orientation of the BS with the test system.
- 3) Set the BS in the declared direction to be tested.
- 4) Connect the BS tester generating the wanted signal, multipath fading simulators and AWGN generators to a test antenna via a combining network in OTA test setup, as shown in annex E.3. Each of the demodulation branch signals should be transmitted one polarization of the test antenna(s).
- 5) The characteristics of the wanted signal shall be configured according to TS 38.211 [20], and according to additional test parameters listed in table 8.3.13.4.2-1.

**Table 8.3.13.4.2-1: Test parameters for PUCCH format 1 with DM-RS bundling**

Parameter	Test 1 [TDD]	Test 2 [FDD]
Example TDD UL-DL pattern (Note1)	15/30 kHz SCS: 7D1S2U, S=6D:4G:4U 60/120 kHz SCS: DDSUU, S=10D:2G:2U or DSUUU, S=10D:2G:2U	
Modulation order	QPSK	QPSK
Intra-slot frequency hopping	disabled	disabled
Number of PRBs	1	1
Number of symbols	14	14
The number of UCI information bits	16	16
Number of slots for PUCCH repetition	2	8
PUCCH-TimeDomainWindowLength	2	8
Note 1: The same TDD requirements are applicable to different UL-DL patterns with more than one consecutive UL slots when both pucch-TimeDomainWindowLength and PUCCH aggregation factor are configured as 2 slots. The UL (re)transmission of PUCCH is only scheduled for the actual TDW including 2 consecutive UL slots.		

- 6) The multipath fading emulators shall be configured according to the corresponding channel model defined in annex J.
- 7) Adjust the test signal mean power so the calibrated radiated SNR value at the BS receiver is as specified in clause 8.3.13.5.1 and 8.3.13.5.2 for *BS type 1-O* and *BS type 2-O* respectively, and the SNR at the BS receiver is not impacted by the noise floor.

The power level for the transmission may be set such that the AWGN level at the RIB is equal to the AWGN level in table 8.3.13.4.2-2.

**Table 8.3.13.4.2-2: AWGN power level at the BS input**

BS type	Subcarrier spacing (kHz)	Channel bandwidth (MHz)	AWGN power level
BS type 1-O (Note 4)	15 kHz	5	$-83.5 - \Delta_{\text{OTAREFSSENS}}$ dBm / 4.5 MHz
	30 kHz	10	$-80.6 - \Delta_{\text{OTAREFSSENS}}$ dBm / 8.64 MHz
BS type 2-O (Note 5)	60 kHz	50	$\text{EIS}_{\text{REFSENS\_50M}} + \Delta_{\text{FR2\_REFSENS}} + 15$ dBm / 47.52 MHz
	120 kHz	50	$\text{EIS}_{\text{REFSENS\_50M}} + \Delta_{\text{FR2\_REFSENS}} + 15$ dBm / 46.08 MHz
NOTE 1: $\Delta_{\text{OTAREFSSENS}}$ as declared in D.53 in table 4.6-1 and clause 7.1.			
NOTE 2: $\Delta_{\text{FR2\_REFSENS}} = -3$ dB as described in clause 7.1, since the OTA REFSSENS reference direction (as declared in D.54 in table 4.6-1) is used for testing.			
NOTE 3: $\text{EIS}_{\text{REFSENS\_50M}}$ as declared in D.28 in table 4.6-1.			
NOTE 4: The AWGN power level contains an AWGN offset of 16dB by default. If needed for test purposes, the AWGN level can be reduced from the default by any value in the range 0dB to 16dB. Changing the AWGN level does not impact the validity of the test, as it reduces the effective base band SNR level.			
NOTE 5: The AWGN power level contains an AWGN offset of 15dB by default. If needed for test purposes, the AWGN level can be reduced from the default by any value in the range 0dB to 15dB. Changing the AWGN level does not impact the validity of the test, as it reduces the effective base band SNR level.			

- 8) The signal generator sends random codewords from applicable codebook, in regular time periods. The following statistics are kept: the number of ACK bits falsely detected in the idle periods and the number of missed ACK bits. Each falsely detected ACK bit in the idle periods is accounted as one error for the statistics of false ACK detection, and each missed ACK bit is accounted as one error for the statistics of missed ACK detection.

Note that the procedure described in this clause for ACK missed detection has the same condition as that described in clause 8.3.12.1.4.2 for NACK to ACK detection. Both statistics are measured in the same testing.



## 8.3.13.5 Test requirement

## 8.3.13.5.1 Test Requirement for BS type 1-O

The fraction of falsely detected ACK bits shall be less than 1 % and the fraction of correctly detected ACK bits shall be larger than 99 % for the SNR listed in table 8.3.13.5.1-1 and table 8.3.13.5.1-2.

Table 8.3.13.5.1-1: Required SNR for PUCCH format 3 with 15 kHz SCS

Test Number	Number of TX antennas	Number of demodulation branches	Cyclic Prefix	Propagation conditions and correlation matrix (annex J)	Additional DM-RS configuration	Channel bandwidth / SNR (dB)
						5 MHz
1	1	2	Normal	TDLA30-10 Low	No additional DM-RS	-0.9
					Additional DM-RS	0.5
2	1	2	Normal	TDLA30-10 Low	No additional DM-RS	-4.7
					Additional DM-RS	-5.2

Table 8.3.13.5.1-2: Required SNR for PUCCH format 3 with 30 kHz SCS

Test Number	Number of TX antennas	Number of demodulation branches	Cyclic Prefix	Propagation conditions and correlation matrix (annex J)	Additional DM-RS configuration	Channel bandwidth / SNR (dB)
						10 MHz
1	1	2	Normal	TDLA30-10 Low	No additional DM-RS	0.8
					Additional DM-RS	0.6
2	1	2	Normal	TDLA30-10 Low	No additional DM-RS	-4.6
					Additional DM-RS	-5

## 8.3.13.5.2 Test Requirement for BS type 2-O

The fraction of falsely detected ACK bits shall be less than 1 % and the fraction of correctly detected ACK bits shall be larger than 99 % for the SNR listed in table 8.3.13.5.2-1 and table 8.3.13.5.2-2.

Table 8.3.13.5.2-1: Required SNR for PUCCH format 3 with 60 kHz SCS

Test Number	Number of TX antennas	Number of demodulation branches	Cyclic Prefix	Propagation conditions and correlation matrix (annex J)	Additional DM-RS configuration	Channel bandwidth / SNR (dB)
						50 MHz
1	1	2	Normal	TDLA30-75 Low	No Additional DM-RS	0.7
2	1	2	Normal	TDLA30-75 Low	Additional DM-RS	0.4

Table 8.3.13.5.2-2: Required SNR for PUCCH format 3 with 120 kHz SCS

Test Number	Number of TX antennas	Number of demodulation branches	Cyclic Prefix	Propagation conditions and correlation matrix (annex J)	Additional DM-RS configuration	Channel bandwidth / SNR (dB)
						50 MHz
1	1	2	Normal	TDLA30-75 Low	No Additional DM-RS	1.3
2	1	2	Normal	TDLA30-75 Low	Additional DM-RS	0.5

## 8.4 OTA performance requirements for PRACH

### 8.4.1 PRACH false alarm probability and missed detection

#### 8.4.1.1 Definition and applicability

The performance requirement of PRACH for preamble detection is determined by the two parameters: total probability of false detection of the preamble (Pfa) and the probability of detection of preamble (Pd). The performance is measured by the required SNR at probability of detection, Pd of 99%. Pfa shall be 0.1% or less.

Pfa is defined as a conditional total probability of erroneous detection of the preamble (i.e. erroneous detection from any detector) when input is only noise.

Pd is defined as conditional probability of detection of the preamble when the signal is present. The erroneous detection consists of several error cases – detecting only different preamble(s) than the one that was sent, not detecting any preamble at all, or detecting the correct preamble but with the out-of-bounds timing estimation value. For AWGN, TDLC300-100, TDLA30-10, TDLA30-300, TDLA30-650, and TDLA10-650, a timing estimation error occurs if the estimation error of the timing of the strongest path is larger than the time error tolerance values given in table 8.4.1.1-1.

**Table 8.4.1.1-1: Time error tolerance for AWGN, TDLC300-100, TDLA30-10, TDLA30-300, TDLA30-650 and TDLA10-650**

PRACH preamble	PRACH SCS (kHz)	Time error tolerance					
		AWGN	TDLC300-100	TDLA30-10	TDLA30-300	TDLA30-650	TDLA10-650
0	1.25	1.04 us	2.55 us	N/A	N/A	N/A	N/A
1	1.25	1.04 us	N/A	N/A	N/A	N/A	N/A
A1, A2, A3, B4, C0, C2	15	0.52 us	2.03 us	0.67 us	N/A	N/A	N/A
	30	0.26 us	1.77 us	0.41 us	N/A	N/A	N/A
	60 (FR2)	0.13 us	N/A	N/A	0.28 us	N/A	N/A
	120	0.07 us	N/A	N/A	0.22 us	0.22 us	N/A
	480	18 ns	N/A	N/A	N/A	N/A	68 ns

The test preambles for normal mode are listed in table A.6-1 and A.6-2. The test preambles for high speed train restricted set type A are listed in table A.6-3 and the test preambles for high speed train restricted set type B are listed in table A.6-4. The test preambles for high speed train short formats are listed in table A.6-5. The test preambles for Multiple PRACH transmission are listed in table A.6-9.

Which specific test(s) are applicable to BS is based on the test applicability rules defined in clause 8.1.2. The performance requirements for high speed train (table 8.4.1.6.1-1 to 8.4.1.6.1-4 and table 8.4.1.6.2-1) are optional. and only applicable for FR2-1 below 30 GHz The test preambles for PRACH with  $L_{RA}=1151$  and  $L_{RA}=571$  are listed in table A.6-6. The performance requirement of format 1 is optional and only for a BS declare to support HAPS scenario (see D.128 in table 4.6-1).

#### 8.4.1.2 Minimum requirement

For *BS type 1-O*, the minimum requirement is in TS 38.104 [2] clause 11.4.1.1 and 11.4.1.2.

For *BS type 2-O*, the minimum requirement is in TS 38.104 [2] clause 11.4.2.1 and 11.4.2.2.

#### 8.4.1.3 Test purpose

The test shall verify the receiver's ability to detect PRACH preamble under static conditions and multipath fading propagation conditions for a given SNR.

#### 8.4.1.4 Method of test

##### 8.4.1.4.1 Initial conditions

Test environment: Normal, see clause B.2.

RF channels to be tested: for single carrier: M; see clause 4.9.1.

Direction to be tested: OTA REFSENS *receiver target reference direction* (see D.54 in table 4.6-1).

##### 8.4.1.4.2 Procedure

- 1) Place the BS with its manufacturer declared coordinate system reference point in the same place as calibrated point in the test system, as shown in annex E.3.
- 2) Align the manufacturer declared coordinate system orientation of the BS with the test system.
- 3) Set the BS in the declared direction to be tested.
- 4) Connect the BS tester generating the wanted signal, multipath fading simulators and AWGN generators to a test antenna via a combining network in OTA test setup, as shown in annex E.3. Each of the demodulation branch signals should be transmitted on one polarization of the test antenna(s).
- 5) The characteristics of the wanted signal shall be configured according to the corresponding UL reference measurement channel defined in annex A and the test parameter *msg1-FrequencyStart* is set to 0.
- 6) The multipath fading emulators shall be configured according to the corresponding channel model defined in annex J.
- 7) Adjust the AWGN generator, according to the SCS and channel bandwidth. The power level for the transmission may be set such that the AWGN level at the RIB is equal to the AWGN level in table 8.4.1.4.2-1.

**Table 8.4.1.4.2-1: AWGN power level at the BS input**

BS type	Sub-carrier spacing (kHz)	Channel bandwidth (MHz)	AWGN power level
BS type 1-O (Note 4)	15	5	-83.5 - $\Delta_{OTAREFSENS}$ dBm / 4.5MHz
		10	-80.3 - $\Delta_{OTAREFSENS}$ dBm / 9.36MHz
		20	-77.2 - $\Delta_{OTAREFSENS}$ dBm / 19.08MHz
	30	10	-80.6 - $\Delta_{OTAREFSENS}$ dBm / 8.64MHz
		20	-77.4 - $\Delta_{OTAREFSENS}$ dBm / 18.36MHz
		40	-74.2 - $\Delta_{OTAREFSENS}$ dBm / 38.16MHz
		100	-70.1 - $\Delta_{OTAREFSENS}$ dBm / 98.28MHz
BS type 2-O (Note 5)	60	50	$EIS_{REFSENS\_50M} + \Delta_{FR2\_REFSENS} + 15$ dBm / 47.52 MHz
		100	$EIS_{REFSENS\_50M} + \Delta_{FR2\_REFSENS} + 18$ dBm / 95.04 MHz
	120	50	$EIS_{REFSENS\_50M} + \Delta_{FR2\_REFSENS} + 15$ dBm / 46.08 MHz
		100	$EIS_{REFSENS\_50M} + \Delta_{FR2\_REFSENS} + 18$ dBm / 95.04 MHz
		200	$EIS_{REFSENS\_50M} + \Delta_{FR2\_REFSENS} + 21$ dBm / 190.08 MHz
		400	$EIS_{REFSENS\_50M} + \Delta_{FR2\_REFSENS} + 24$ dBm / 380.16 MHz
	480	400	$EIS_{REFSENS\_50M} + \Delta_{FR2\_REFSENS} + 24$ dBm / 380.16 MHz
	<p>NOTE 1: <math>\Delta_{OTAREFSENS}</math> as declared in D.53 in table 4.6-1 and clause 7.1.</p> <p>NOTE 2: <math>\Delta_{FR2\_REFSENS} = -3</math> dB as described in clause 7.1, since the OTA REFSSENS receiver target reference direction (as declared in D.54 in table 4.6-1) is used for testing.</p> <p>NOTE 3: <math>EIS_{REFSENS\_50M}</math> as declared in D.28 in table 4.6-1.</p> <p>NOTE 4: The AWGN power level contains an AWGN offset of 16dB by default. If needed for test purposes, the AWGN level can be reduced from the default by any value in the range 0dB to 16dB. Changing the AWGN level does not impact the validity of the test, as it reduces the effective base band SNR level.</p> <p>NOTE 5: The AWGN power level contains an AWGN offset of 15dB by default. If needed for test purposes, the AWGN level can be reduced from the default by any value in the range 0dB to 15dB. Changing the AWGN level does not impact the validity of the test, as it reduces the effective base band SNR level.</p>		

- 8) Adjust the frequency offset of the test signal according to table 8.4.1.5.1-1 or 8.4.1.5.1-2 or 8.4.1.5.1-3 or 8.4.1.6.1-1 or 8.4.1.6.1-2 or 8.4.1.6.1-3 or 8.4.1.6.1-4 or 8.4.1.5.2-1 or 8.4.1.5.2-2 or 8.4.1.5.2-3 or 8.4.1.5.2-4 or 8.4.1.5.2-5 or 8.4.1.7.1-1 or 8.4.1.7.1-2 or 8.4.1.6.2-1 or 8.4.1.7.x-1 or 8.4.1.7.x-2 or 8.4.1.7.x-3.
- 9) Adjust the equipment so that the SNR specified in table 8.4.1.5.1-1 or 8.4.1.5.1-2 or 8.4.1.5.1-3 or 8.4.1.6.1-1 or 8.4.1.6.1-2 or 8.4.1.6.1-3 or 8.4.1.6.1-4 or 8.4.1.5.2-1 or 8.4.1.5.2-2 or 8.4.1.5.2-3 or 8.4.1.5.2-4 or 8.4.1.5.2-5 or 8.4.1.7.1-1 or 8.4.1.7.1-2 or 8.4.1.6.2-1 or 8.4.1.7.x-1 or 8.4.1.7.x-2 or 8.4.1.7.x-3 is achieved at the BS input during the PRACH preambles.
- 10) The test signal generator sends a preamble and the receiver tries to detect the preamble. This pattern is repeated as illustrated in figure 8.4.1.4.2-1. The preambles are sent with certain timing offsets as described below. The following statistics are kept: the number of preambles detected in the idle period and the number of missed preambles.



**Figure 8.4.1.4.2-1: PRACH preamble test pattern**

Unless otherwise stated, the timing offset base value for PRACH preamble format 0 is set to 50% of Ncs. This offset is increased within the loop, by adding in each step a value of 0.1us, until the end of the tested range, which is 0.9us. Then the loop is being reset and the timing offset is set again to 50% of Ncs. The timing offset scheme for PRACH preamble format 0 and 1 is presented in Figure 8.4.1.4.2-2.

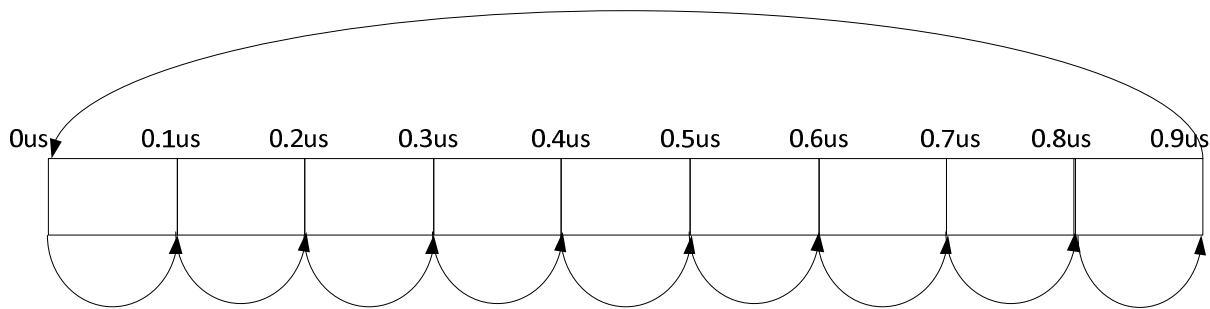

**Figure 8.4.1.4.2-2: Timing offset scheme for PRACH preamble format 0 and 1**

Unless otherwise stated, the timing offset base value for PRACH preamble format A1, A2, A3, B4, C0 and C2 is set to 0. This offset is increased within the loop, by adding in each step a value of 0.1us, until the end of the tested range, which is 0.8us. Then the loop is being reset and the timing offset is set again to 0. The timing offset scheme for PRACH preamble format A1, A2, A3, B4, C0 and C2 is presented in Figure 8.4.1.4.2-3 for 15 kHz, 30 kHz, 60 kHz, and 120 kHz SCS.

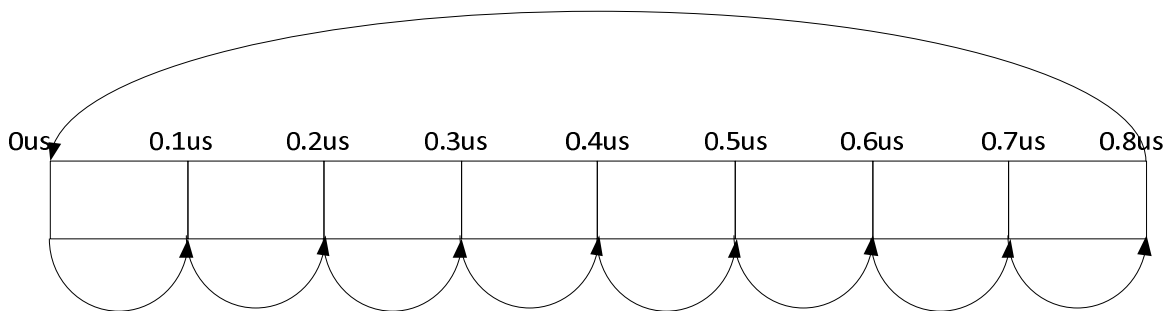

**Figure 8.4.1.4.2-3: Timing offset scheme for PRACH preamble format A1, A2, A3, B4, C0 and C2 using 15 kHz, 30 kHz, 60 kHz, and 120 kHz SCS**

For test requirement specified in Table 8.4.1.6.2-1, the timing offset base value for PRACH preamble format C2 is set to 0. This offset is increased within the loop, by adding in each step a value of 0.48us, until the end of the tested range, which is 4.8us. Then the loop is being reset and the timing offset is set again to 0. The timing offset scheme for PRACH preamble format C2 is presented in Figure 8.4.1.4.2-4.

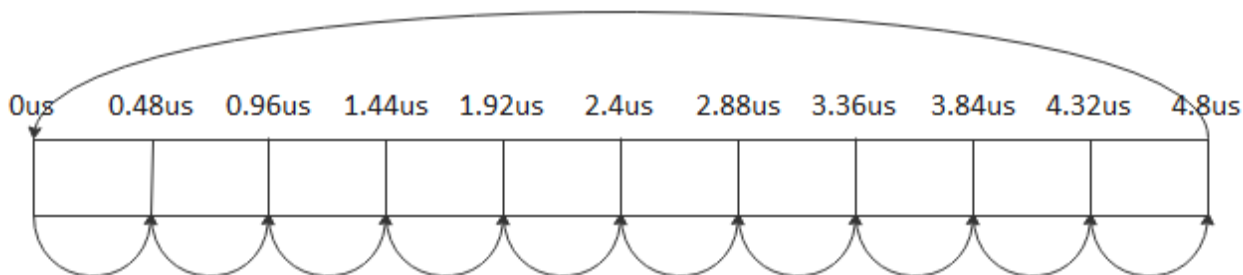

**Figure 8.4.1.4.2-4: Timing offset scheme for PRACH preamble format C2**

For test requirements with 480 kHz SCS, the timing offset base value for PRACH preamble format A2, B4, and C2 is set to 0. This offset is increased within the loop, by adding in each step a value of 0.1us, until the end of the tested range, which is 0.4us. Then the loop is being reset and the timing offset is set again to 0. The timing offset scheme for PRACH preamble format A2, B4, and C2 is presented in Figure 8.4.1.4.2-5.

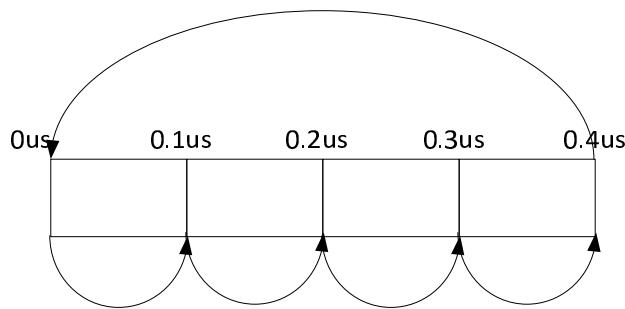

Figure 8.4.1.4.2-5: Timing offset scheme for PRACH preamble format A2, B4, and C2 using 480 kHz SCS

8.4.1.5 Test requirement for Normal Mode

8.4.1.5.1 Test requirement for BS type 1-0

P<sub>fa</sub> shall not exceed 0.1%. P<sub>d</sub> shall not be below 99% for the SNRs in tables 8.4.1.5.1-1 to 8.4.1.5.1-3.

Table 8.4.1.5.1-1: PRACH missed detection test requirements for Normal Mode, 1.25 kHz SCS

Number of TX antennas	Number of demodulation branches	Propagation conditions and correlation matrix (annex J)	Frequency offset	SNR (dB)	
				Burst format 0	Burst format 1
1	2	AWGN	0	-14.2	-16.2
		TDLC300-100 Low	400 Hz	-6.0	N/A

Table 8.4.1.5.1-2: PRACH missed detection test requirements for Normal Mode, 15 kHz SCS

Number of TX antennas	Number of demodulation branches	Propagation conditions and correlation matrix (annex J)	Frequency offset	SNR (dB)					
				Burst format A1	Burst format A2	Burst format A3	Burst format B4	Burst format C0	Burst format C2
1	2	AWGN	0	-9.0	-12.3	-13.9	-16.5	-6.0	-12.2
		TDLC300-100 Low	400 Hz	-1.5	-4.2	-6.0	-8.2	1.4	-4.3

Table 8.4.1.5.1-3: PRACH missed detection test requirements for Normal Mode, 30 kHz SCS

Number of TX antennas	Number of demodulation branches	Propagation conditions and correlation matrix (annex J)	Frequency offset	SNR (dB)					
				Burst format A1	Burst format A2	Burst format A3	Burst format B4	Burst format C0	Burst format C2
1	2	AWGN	0	-8.8	-11.7	-13.5	-16.2	-5.8	-11.6
		TDLC300-100 Low	400 Hz	-2.2	-5.1	-6.8	-9.3	0.7	-5.0

Table 8.4.1.5.1-4: Void

Table 8.4.1.5.1-5: Void

8.4.1.5.2 Test requirement for *BS type 2-0*

Pfa shall not exceed 0.1%. Pd shall not be below 99% for the SNRs in tables 8.4.1.5.2-1 to 8.4.1.5.2-4.

Table 8.4.1.5.2-1: PRACH missed detection test requirements for Normal Mode, 60 kHz SCS in FR2-1

Number of TX antennas	Number of demodulation branches	Propagation conditions and correlation matrix (annex J)	Frequency offset	SNR (dB)					
				Burst format A1	Burst format A2	Burst format A3	Burst format B4	Burst format C0	Burst format C2
1	2	AWGN	0	-8.6	-11.6	-13.2	-15.5	-5.7	-11.5
		TDLA30-300 Low	4000 Hz	-1.0	-3.2	-4.2	-6.3	1.7	-3.3

Table 8.4.1.5.2-2: PRACH missed detection test requirements for Normal Mode, 120 kHz SCS in FR2-1

Number of TX antennas	Number of demodulation branches	Propagation conditions and correlation matrix (annex J)	Frequency offset	SNR (dB)					
				Burst format A1	Burst format A2	Burst format A3	Burst format B4	Burst format C0	Burst format C2
1	2	AWGN	0	-8.4	-11.2	-13.0	-15.5	-5.5	-11.1
		TDLA30-300 Low	4000 Hz	-1.1	-3.8	-5.2	-6.9	1.8	-3.6

Table 8.4.1.5.2-3: PRACH missed detection test requirements for Normal Mode, 120 kHz SCS in FR2-2

Number of TX antennas	Number of demodulation branches	Propagation conditions and correlation matrix (Annex J)	Frequency offset	SNR (dB)		
				Burst format A2	Burst format B4	Burst format C2
1	2	AWGN	0	-11.5	-15.7	-11.5
		TDLA30-650 Low	7100	-3.4	-6.7	-3.6

Table 8.4.1.5.2-4: PRACH missed detection test requirements for Normal Mode, 480 kHz SCS in FR2-2

Number of TX antennas	Number of demodulation branches	Propagation conditions and correlation matrix (Annex J)	Frequency offset	SNR (dB)		
				Burst format A2	Burst format B4	Burst format C2
1	2	AWGN	0	-11.4	-15.6	-11.5
		TDLA10-650 Low	7100	-3.9	-8.7	-3.9

## 8.4.1.6 Test requirement for high speed train

8.4.1.6.1 Test requirement for *BS type 1-0*

Pfa shall not exceed 0.1%. Pd shall not be below 99% for the SNRs in tables 8.4.1.6.1-1 to 8.4.1.6.1-4.

**Table 8.4.1.6.1-1: PRACH missed detection requirements for high speed train, burst format 0, restricted set type A, 1.25 kHz SCS**

Number of TX antennas	Number of demodulation branches	Propagation conditions and correlation matrix (annex J)	Frequency offset	SNR (dB)
				Burst format 0
1	2	AWGN	625 Hz	-11.7
		AWGN	1340 Hz	-13.5
		TDLC300-100 Low	0 Hz	-5.7

**Table 8.4.1.6.1-2: PRACH missed detection requirements for high speed train, burst format 0, restricted set type B, 1.25 kHz SCS**

Number of TX antennas	Number of demodulation branches	Propagation conditions and correlation matrix (annex J)	Frequency offset	SNR (dB)
				Burst format 0
1	2	AWGN	625 Hz	-11.3
		AWGN	2334 Hz	-12.8
		TDLC300-100 Low	0 Hz	-5.4

**Table 8.4.1.6.1-3: PRACH missed detection requirements for high speed train, 15 kHz SCS**

Number of TX antennas	Number of demodulation branches	Propagation conditions and correlation matrix (Annex J)	Frequency offset	SNR (dB)		
				Burst format A2	Burst format B4	Burst format C2
1	2	AWGN	1740 Hz	-11.0	-14.0	-10.8

**Table 8.4.1.6.1-4: PRACH missed detection requirements for high speed train, 30 kHz SCS**

Number of TX antennas	Number of demodulation branches	Propagation conditions and correlation matrix (Annex J)	Frequency offset	SNR (dB)		
				Burst format A2	Burst format B4	Burst format C2
1	2	AWGN	3334 Hz	-10.9	-14.3	-10.7

#### 8.4.1.6.2 Test requirement for *BS type 2-0*

P<sub>fa</sub> shall not exceed 0.1%. P<sub>d</sub> shall not be below 99% for the SNRs in Table 8.4.1.6.2-1.

**Table 8.4.1.6.2-1: PRACH missed detection requirements for high speed train, 120 kHz SCS**

Number of TX antennas	Number of RX antennas	Propagation conditions (Annex J)	Frequency offset	SNR (dB)
				Burst format C2
1	2	AWGN	19444 Hz	-9.8

#### 8.4.1.7 Test requirement for PRACH with L<sub>RA</sub>=1151 and L<sub>RA</sub>=571

##### 8.4.1.7.1 Test requirement for *BS type 1-0*

P<sub>fa</sub> shall not exceed 0.1%. P<sub>d</sub> shall not be below 99% for the SNRs in tables 8.4.1.7.1-1 to 8.4.1.7.1-2.



**Table 8.4.1.7.1-1: Missed detection requirements for PRACH with  $L_{RA}=1151$ , 15 kHz SCS**

Number of TX antennas	Number of demodulation branches	Propagation conditions and correlation matrix (Annex J)	Frequency offset	SNR (dB)		
				Burst format A2	Burst format B4	Burst format C2
1	2	AWGN	0	-20.8	-24.8	-20.8
		TDLA30-10 Low	400 Hz	-14.5	-17.7	-14.6

**Table 8.4.1.7.1-2: Missed detection requirements for PRACH with  $L_{RA}=571$ , 30 kHz SCS**

Number of TX antennas	Number of demodulation branches	Propagation conditions and correlation matrix (Annex J)	Frequency offset	SNR (dB)		
				Burst format A2	Burst format B4	Burst format C2
1	2	AWGN	0	-17.8	-21.7	-17.8
		TDLA30-10 Low	400 Hz	-11.5	-15.2	-11.5

#### 8.4.1.7.2 Test requirement for *BS type 2-0*

$P_{fa}$  shall not exceed 0.1%.  $P_d$  shall not be below 99% for the SNRs in tables 8.4.1.7.2-1 to 8.4.1.7.2-3.

**Table 8.4.1.7.2-1: Missed detection requirements for PRACH with  $L_{RA}=571$ , 120 kHz SCS**

Number of TX antennas	Number of demodulation branches	Propagation conditions and correlation matrix (Annex J)	Frequency offset	SNR (dB)		
				Burst format A2	Burst format B4	Burst format C2
1	2	AWGN	0	-17.6	-21.8	-17.6
		TDLA30-650 Low	7100	-10.3	-13.2	-10.1

**Table 8.4.1.7.2-2: Missed detection requirements for PRACH with  $L_{RA}=1151$ , 120 kHz SCS**

Number of TX antennas	Number of demodulation branches	Propagation conditions and correlation matrix (Annex J)	Frequency offset	SNR (dB)		
				Burst format A2	Burst format B4	Burst format C2
1	2	AWGN	0	-20.6	-24.7	-20.5
		TDLA30-650 Low	7100	-13.4	-16.3	-13.4

**Table 8.4.1.7.2-3: Missed detection requirements for PRACH with  $L_{RA}=571$ , 480 kHz SCS**

Number of TX antennas	Number of demodulation branches	Propagation conditions and correlation matrix (Annex J)	Frequency offset	SNR (dB)		
				Burst format A2	Burst format B4	Burst format C2
1	2	AWGN	0	-17.6	-21.7	-17.6
		TDLA10-650 Low	7100	-10.5	-14.4	-10.5

### 8.4.1.8 Test requirement for PRACH with repetition transmission

#### 8.4.1.8.1 Test requirement for *BS type 2-0*

P<sub>fa</sub> shall not exceed 0.1%. P<sub>d</sub> shall not be below 99% for the SNRs in tables 8.4.1.8.1-1

**Table 8.4.1.8.1-1: PRACH missed detection test requirements with repetition transmission, 120 kHz SCS in FR2-1**

Number of TX antennas	Number of demodulation branches	Propagation conditions and correlation matrix (Annex J)	Frequency offset	Number of Repetitions	SNR (dB)		
					Burst format A2	Burst format B4	Burst format C2
1	2	TDLA30-300 Low	4000 Hz	2	[-7.1]	[-11.8]	[-7.1]

Note : This requirement has no limitation for PRACH configuration index selection for BS conformance testing

## Annex A (normative): Reference measurement channels

### A.1 Fixed Reference Channels for OTA sensitivity, OTA reference sensitivity level, OTA ACS, OTA in-band blocking, OTA out-of-band blocking, OTA receiver intermodulation and OTA in-channel selectivity (QPSK, R=1/3)

The parameters for the reference measurement channels are specified in table A.1-1 for FR1 OTA sensitivity, OTA reference sensitivity level, OTA ACS, OTA in-band blocking, OTA out-of-band blocking, OTA receiver intermodulation and OTA in-channel selectivity.

The parameters for the reference measurement channels are specified in table A.1-2 for FR2 OTA reference sensitivity level, OTA ACS, OTA in-band blocking, OTA out-of-band blocking, OTA receiver intermodulation and OTA in-channel selectivity.

**Table A.1-1: FRC parameters for FR1 OTA sensitivity, OTA reference sensitivity level, OTA ACS, OTA in-band blocking, OTA out-of-band blocking, OTA receiver intermodulation and OTA in-channel selectivity**

Reference channel	G-FR1-A1-1	G-FR1-A1-2	G-FR1-A1-3	G-FR1-A1-4	G-FR1-A1-5	G-FR1-A1-6	G-FR1-A1-7	G-FR1-A1-8	G-FR1-A1-9
Subcarrier spacing (kHz)	15	30	60	15	30	60	15	30	60
Allocated resource blocks	25	11	11	106	51	24	15	6	6
CP-OFDM Symbols per slot (Note 1)	12	12	12	12	12	12	12	12	12
Modulation	QPSK	QPSK	QPSK	QPSK	QPSK	QPSK	QPSK	QPSK	QPSK
Code rate (Note 2)	1/3	1/3	1/3	1/3	1/3	1/3	1/3	1/3	1/3
Payload size (bits)	2152	984	984	9224	4352	2088	1320	528	528
Transport block CRC (bits)	16	16	16	24	24	16	16	16	16
Code block CRC size (bits)	-	-	-	24	-	-	-	-	-
Number of code blocks - C	1	1	1	2	1	1	1	1	1
Code block size including CRC (bits) (Note 3)	2168	1000	1000	4648	4376	2104	1336	544	544
Total number of bits per slot	7200	3168	3168	30528	14688	6912	4320	1728	1728
Total symbols per slot	3600	1584	1584	15264	7344	3456	2160	864	864
NOTE 1: DM-RS configuration type = 1 with DM-RS duration = single-symbol DM-RS, additional DM-RS position = pos1 with $l_0 = 2$ , $l = 11$ as per table 6.4.1.1.3-3 of TS 38.211 [20].									
NOTE 2: MCS index 4 and target coding rate = 308/1024 are adopted to calculate payload size.									
NOTE 3: Code block size including CRC (bits) equals to $K'$ in TS 38.212 [19], clause 5.2.2.									

Table A.1-1a: FRC parameters for band n96 OTA sensitivity, for BS Type 1-H

Reference channel	G-FR1-A1-12	G-FR1-A1-13	G-FR1-A1-14	G-FR1-A1-15	G-FR1-A1-16	G-FR1-A1-17	G-FR1-A1-18	G-FR1-A1-19
Channel bandwidth (MHz)	10	10	20	20	40	40	60	80
Subcarrier spacing (kHz)	15	30	15	30	15	30	30	30
Allocated resource blocks	5	4	10	10	21	21	32	43
CP-OFDM Symbols per slot (Note 1)	12	12	12	12	12	12	12	12
Modulation	QPSK	QPSK	QPSK	QPSK	QPSK	QPSK	QPSK	QPSK
Code rate (Note 2)	1/3	1/3	1/3	1/3	1/3	1/3	1/3	1/3
Payload size (bits)	432	352	888	888	1864	1864	2792	3752
Transport block CRC (bits)	16	16	16	16	16	16	16	16
Code block CRC size (bits)	-	-	-	-	-	-	-	-
Number of code blocks - C	1	1	1	1	1	1	1	1
Code block size including CRC (bits) (Note 3)	448	368	904	904	1880	1880	2808	3768
Total number of bits per slot	1440	1152	2880	2880	6048	6048	9216	12384
Total symbols per slot	720	576	1440	1440	3024	3024	4608	6192

NOTE 1: *UL-DMRS-config-type* = 1 with *UL-DMRS-max-len* = 1, *UL-DMRS-add-pos* = 1 with  $l_0 = 2$ ,  $l = 11$  as per table 6.4.1.1.3-3 of TS 38.211 [20].

NOTE 2: MCS index 4 and target coding rate = 308/1024 are adopted to calculate payload size for receiver sensitivity and in-channel selectivity

NOTE 3: Code block size including CRC (bits) equals to  $K'$  in sub-clause 5.2.2 of TS 38.212 [19].

NOTE 4: For reference channel A1-12, the allocated RB's are uniformly spaced over the channel bandwidth at RB index  $N$ ,  $N+10$ ,  $N+20$ ,  $N+30$ ,  $N+40$  where  $N=\{0,1,2,3,4,\dots,9\}$ .

NOTE 5: For reference channel A1-13, the allocated RB's are uniformly spaced over the channel bandwidth at RB index  $N$ ,  $N+5$ ,  $N+10$ ,  $N+15$  where  $N=\{0,1,2,3,4\}$ .

NOTE 7: For reference channel A1-14, the allocated RB's are uniformly spaced over the channel bandwidth at RB index  $N$ ,  $N+10$ ,  $N+20$ , ...,  $N+90$  where  $N=\{0,1,2,3,\dots,9\}$ .

NOTE 8: For reference channel A1-15, the allocated RB's are uniformly spaced over the channel bandwidth at RB index  $N$ ,  $N+5$ ,  $N+10$ , ...,  $N+45$  where  $N=\{0,1,2,3,4\}$ .

NOTE 10: For reference channel A1-16, the allocated RB's are uniformly spaced over the channel bandwidth at RB index  $N$ ,  $N+10$ ,  $N+20$ , ...,  $N+200$  where  $N=\{0,1,2,3,4,\dots,9\}$ .

NOTE 11: For reference channel A1-17, the allocated RB's are uniformly spaced over the channel bandwidth at RB index  $N$ ,  $N+5$ ,  $N+10$ , ...,  $N+100$  where  $N=\{0,1,2,3,4\}$ .

NOTE 12: For reference channel A1-18, the allocated RB's are uniformly spaced over the channel bandwidth at RB index  $N$ ,  $N+5$ ,  $N+10$ , ...,  $N+155$  where  $N=\{0,1,2,3,4\}$ .

NOTE 13: For reference channel A1-19, the allocated RB's are uniformly spaced over the channel bandwidth at RB index  $N$ ,  $N+5$ ,  $N+10$ , ...,  $N+210$  where  $N=\{0,1,2,3,4\}$ .

**Table A.1-2: FRC parameters for FR2 OTA reference sensitivity level, OTA ACS, OTA in-band blocking, OTA out-of-band blocking, OTA receiver intermodulation and OTA in-channel selectivity**

Reference channel	G-FR2-A1-1	G-FR2-A1-2	G-FR2-A1-3	G-FR2-A1-4	G-FR2-A1-5
Subcarrier spacing (kHz)	60	120	120	60	120
Allocated resource blocks	66	32	66	33	16
CP-OFDM Symbols per slot (Note 1)	12	12	12	12	12
Modulation	QPSK	QPSK	QPSK	QPSK	QPSK
Code rate (Note 2)	1/3	1/3	1/3	1/3	1/3
Payload size (bits)	5632	2792	5632	2856	1416
Transport block CRC (bits)	24	16	24	16	16
Code block CRC size (bits)	-	-	-	-	-
Number of code blocks - C	1	1	1	1	1
Code block size including CRC (bits) (Note 3)	5656	2808	5656	2872	1432
Total number of bits per slot	19008	9216	19008	9504	4608
Total symbols per slot	9504	4608	9504	4752	2304
NOTE 1: DM-RS configuration type = 1 with DM-RS duration = single-symbol DM-RS, additional DM-RS position = pos1 with $l_0 = 2$ , $l = 11$ as per table 6.4.1.1.3-3 of TS 38.211 [20].					
NOTE 2: MCS index 4 and target coding rate = 308/1024 are adopted to calculate payload size.					
NOTE 3: Code block size including CRC (bits) equals to $K'$ in TS 38.212 [19], clause 5.2.2.					

## A.2 Fixed Reference Channels for OTA dynamic range (16QAM, R=2/3)

The parameters for the reference measurement channels are specified in table A.2-1 for FR1 OTA dynamic range.

**Table A.2-1: FRC parameters for FR1 OTA dynamic range**

Reference channel	G-FR1-A2-1	G-FR1-A2-2	G-FR1-A2-3	G-FR1-A2-4	G-FR1-A2-5	G-FR1-A2-6
Subcarrier spacing (kHz)	15	30	60	15	30	60
Allocated resource blocks	25	11	11	106	51	24
CP-OFDM Symbols per slot (Note 1)	12	12	12	12	12	12
Modulation	16QAM	16QAM	16QAM	16QAM	16QAM	16QAM
Code rate (Note 2)	2/3	2/3	2/3	2/3	2/3	2/3
Payload size (bits)	9224	4032	4032	38936	18960	8968
Transport block CRC (bits)	24	24	24	24	24	24
Code block CRC size (bits)	24	-	-	24	24	24
Number of code blocks - C	2	1	1	5	3	2
Code block size including CRC (bits) (Note 3)	4648	4056	4056	7816	6352	4520
Total number of bits per slot	14400	6336	6336	61056	29376	13824
Total symbols per slot	3600	1584	1584	15264	7344	3456
NOTE 1: DM-RS configuration type = 1 with DM-RS duration = single-symbol DM-RS, additional DM-RS position = pos1 with $l_0 = 2$ , $l = 11$ as per table 6.4.1.1.3-3 of TS 38.211 [20].						
NOTE 2: MCS index 16 and target coding rate = 658/1024 are adopted to calculate payload size.						
NOTE 3: Code block size including CRC (bits) equals to $K'$ in TS 38.212 [19], clause 5.2.2.						

## A.3 Fixed Reference Channels for performance requirements (QPSK, R=193/1024)

The parameters for the reference measurement channels are specified in table A.3-2, table A.3-2A, table A.3-4 and table A.3-6 for FR1 PUSCH performance requirements:

- FRC parameters are specified in table A.3-2 for FR1 PUSCH with transform precoding disabled, additional DM-RS position = pos1 and 1 transmission layer.

FRC parameters are specified in table A.3-2A for FR1 PUSCH with transform precoding disabled, additional DM-RS position = pos2 and 1 transmission layer.

- FRC parameters are specified in table A.3-4 for FR1 PUSCH with transform precoding disabled, additional DM-RS position = pos1 and 2 transmission layers.
- FRC parameters are specified in table A.3-6 for FR1 PUSCH with transform precoding enabled, additional DM-RS position = pos1 and 1 transmission layer.

The parameters for the reference measurement channels are specified in table A.3-14 for FR1 PUSCH performance requirements for TBoMS:

- FRC parameters are specified in table A.3-14 for FR1 PUSCH with transform precoding disabled, *Additional DM-RS position = pos1* and 1 transmission layer.

The parameters for the reference measurement channels are specified in table A.3-7 to table A.3-12 for FR2 PUSCH performance requirements:

- FRC parameters are specified in table A.3-7 for FR2 PUSCH with transform precoding disabled, additional DM-RS position = pos0 and 1 transmission layer.
- FRC parameters are specified in table A.3-8 for FR2 PUSCH with transform precoding disabled, additional DM-RS position = pos0 and 2 transmission layer.
- FRC parameters are specified in table A.3-9 for FR2 PUSCH with transform precoding enabled, additional DM-RS position = pos0 and 1 transmission layer.
- FRC parameters are specified in table A.3-10 for FR2 PUSCH with transform precoding disabled, additional DM-RS position = pos1 and 1 transmission layer.
- FRC parameters are specified in table A.3-11 for FR2 PUSCH with transform precoding disabled, additional DM-RS position = pos1 and 2 transmission layer.
- FRC parameters are specified in table A.3-12 for FR2 PUSCH with transform precoding enabled, additional DM-RS position = pos1 and 1 transmission layer.

The parameters for the reference measurement channels are specified in table A.3-13 for FR2 PUSCH performance requirements for 2-step RA type:

- FRC parameters are specified in table A.3-13 for FR2 PUSCH with transform precoding disabled, *Additional DM-RS position = pos1* and 1 transmission layer.

The parameters for the reference measurement channels are specified in table A.3-15 for FR2 PUSCH performance requirements for TBoMS:

- FRC parameters are specified in table A.3-15 for FR2 PUSCH with transform precoding disabled, *Additional DM-RS position = pos1* and 1 transmission layer.

Note: The FRC table A.3-16 defined in TS38.104 [2] and TS38.141-1 [3] is not used in this specification.

Table A.3-1: Void

Table A.3-2: FRC parameters for FR1 PUSCH performance requirements, transform precoding disabled, additional DM-RS position = pos1 and 1 transmission layer (QPSK, R=193/1024)

Reference channel	G-FR1-A3-8	G-FR1-A3-9	G-FR1-A3-10	G-FR1-A3-11	G-FR1-A3-12	G-FR1-A3-13	G-FR1-A3-14
Subcarrier spacing (kHz)	15	15	15	30	30	30	30
Allocated resource blocks	25	52	106	24	51	106	273
CP-OFDM Symbols per slot (Note 1)	12	12	12	12	12	12	12
Modulation	QPSK	QPSK	QPSK	QPSK	QPSK	QPSK	QPSK
Code rate (Note 2)	193/1024	193/1024	193/1024	193/1024	193/1024	193/1024	193/1024
Payload size (bits)	1352	2856	5768	1320	2792	5768	14856
Transport block CRC (bits)	16	16	24	16	16	24	24
Code block CRC size (bits)	-	-	24	-	-	24	24
Number of code blocks - C	1	1	2	1	1	2	4
Code block size including CRC (bits) (Note 2)	1368	2872	2920	1336	2808	2920	3744
Total number of bits per slot	7200	14976	30528	6912	14688	30528	78624
Total symbols per slot	3600	7488	15264	3456	7344	15264	39312
NOTE 1: DM-RS configuration type = 1 with DM-RS duration = single-symbol DM-RS and the number of DM-RS CDM groups without data is 2, additional DM-RS position = pos1, $l_0 = 2$ and $l = 11$ for PUSCH mapping type A, $l_0 = 0$ and $l = 10$ for PUSCH mapping type B as per table 6.4.1.1.3-3 of TS 38.211 [20].							
NOTE 2: Code block size including CRC (bits) equals to $K'$ in clause 5.2.2 of TS 38.212 [19].							

Table A.3-2A: FRC parameters for FR1 PUSCH performance requirements, transform precoding disabled, additional DM-RS position = pos2 and 1 transmission layer (QPSK, R=193/1024)

Reference channel	G-FR1-A3-33	G-FR1-A3-33A	G-FR1-A3-34	G-FR1-A3-34A
Subcarrier spacing [kHz]	15	15	30	30
Allocated resource blocks	52	25	106	24
Data bearing CP-OFDM Symbols per slot (Note 1)	11	11	11	11
Modulation	QPSK	QPSK	QPSK	QPSK
Code rate (Note 2)	193/1024	193/1024	193/1024	193/1024
Payload size (bits)	2600	1256	5256	1192
Transport block CRC (bits)	16	16	24	16
Code block CRC size (bits)	-	-	24	-
Number of code blocks - C	1	1	2	1
Code block size including CRC (bits) (Note 2)	2616	1272	2664	1208
Total number of bits per slot	13728	6600	27984	6336
Total resource elements per slot	6846	3300	13992	3168
NOTE 1: DM-RS configuration type = 1 with DM-RS duration = single-symbol DM-RS and the number of DM-RS CDM groups without data is 2, Additional DM-RS position = pos2, and $l_0 = 2$ or 3 for PUSCH mapping type A, as per table 6.4.1.1.3-3 of TS 38.211 [20].				
NOTE 2: Code block size including CRC (bits) equals to $K'$ in clause 5.2.2 of TS 38.212 [19].				

Table A.3-3: Void

Table A.3-4: FRC parameters for FR1 PUSCH performance requirements, transform precoding disabled, additional DM-RS position = pos1 and 2 transmission layers (QPSK, R=193/1024)

Reference channel	G-FR1-A3-22	G-FR1-A3-23	G-FR1-A3-24	G-FR1-A3-25	G-FR1-A3-26	G-FR1-A3-27	G-FR1-A3-28
Subcarrier spacing (kHz)	15	15	15	30	30	30	30
Allocated resource blocks	25	52	106	24	51	106	273
CP-OFDM Symbols per slot (Note 1)	12	12	12	12	12	12	12
Modulation	QPSK	QPSK	QPSK	QPSK	QPSK	QPSK	QPSK
Code rate (Note 2)	193/1024	193/1024	193/1024	193/1024	193/1024	193/1024	193/1024
Payload size (bits)	2728	5640	11528	2600	5512	11528	29736
Transport block CRC (bits)	16	24	24	16	24	24	24
Code block CRC size (bits)	-	24	24	-	24	24	24
Number of code blocks - C	1	2	4	1	2	4	8
Code block size including CRC (bits) (Note 2)	2744	2856	2912	2616	2792	2912	3744
Total number of bits per slot	14400	29952	61056	13824	29376	61056	157248
Total symbols per slot	7200	14976	30528	6912	14688	30528	78624
NOTE 1: DM-RS configuration type = 1 with DM-RS duration = single-symbol DM-RS and the number of DM-RS CDM groups without data is 2, additional DM-RS position = pos1, $l_0 = 2$ and $l = 11$ for PUSCH mapping type A, $l_0 = 0$ and $l = 10$ for PUSCH mapping type B as per table 6.4.1.1.3-3 of TS 38.211 [20].							
NOTE 2: Code block size including CRC (bits) equals to $K'$ in clause 5.2.2 of TS 38.212 [19].							

Table A.3-5: Void

Table A.3-6: FRC parameters for FR1 PUSCH performance requirements, transform precoding enabled, additional DM-RS position = pos1 and 1 transmission layer (QPSK, R=193/1024)

Reference channel	G-FR1-A3-31	G-FR1-A3-32
Subcarrier spacing (kHz)	15	30
Allocated resource blocks	25	24
DFT-s-OFDM Symbols per slot (Note 1)	12	12
Modulation	QPSK	QPSK
Code rate (Note 2)	193/1024	193/1024
Payload size (bits)	1352	1320
Transport block CRC (bits)	16	16
Code block CRC size (bits)	-	-
Number of code blocks - C	1	1
Code block size including CRC (bits) (Note 2)	1368	1336
Total number of bits per slot	7200	6912
Total symbols per slot	3600	3456
NOTE 1: DM-RS configuration type = 1 with DM-RS duration = single-symbol DM-RS and the number of DM-RS CDM groups without data is 2, additional DM-RS position = pos1, $l_0 = 2$ and $l = 11$ for PUSCH mapping type A, $l_0 = 0$ and $l = 10$ for PUSCH mapping type B as per table 6.4.1.1.3-3 of TS 38.211 [20].		
NOTE 2: Code block size including CRC (bits) equals to $K'$ in clause 5.2.2 of TS 38.212 [19].		



**Table A.3-7: FRC parameters for FR2 PUSCH performance requirements, transform precoding disabled, additional DM-RS position = pos0 and 1 transmission layer (QPSK, R=193/1024)**

Reference channel	G-FR2-A3-1	G-FR2-A3-2	G-FR2-A3-3	G-FR2-A3-4	G-FR2-A3-5
Subcarrier spacing (kHz)	60	60	120	120	120
Allocated resource blocks	66	132	32	66	132
CP-OFDM Symbols per slot (Note 1)	9	9	9	9	9
Modulation	QPSK	QPSK	QPSK	QPSK	QPSK
Code rate (Note 2)	193/1024	193/1024	193/1024	193/1024	193/1024
Payload size (bits)	2664	5384	1320	2664	5384
Transport block CRC (bits)	16	24	16	16	24
Code block CRC size (bits)	-	24	-	-	24
Number of code blocks - C	1	2	1	1	2
Code block size including CRC (bits) (Note 2)	2680	2728	1336	2680	2728
Total number of bits per slot	14256	28512	6912	14256	28512
Total symbols per slot	7128	14256	3456	7128	14256
NOTE 1: DM-RS configuration type = 1 with DM-RS duration = single-symbol DM-RS and the number of DM-RS CDM groups without data is 2, additional DM-RS position = pos0 with $l_0 = 0$ as per table 6.4.1.1.3-3 of TS 38.211 [20].					
NOTE 2: Code block size including CRC (bits) equals to $K'$ in clause 5.2.2 of TS 38.212 [19].					

**Table A.3-8: FRC parameters for FR2 PUSCH performance requirements, transform precoding disabled, additional DM-RS position = pos0 and 2 transmission layers (QPSK, R=193/1024)**

Reference channel	G-FR2-A3-6	G-FR2-A3-7	G-FR2-A3-8	G-FR2-A3-9	G-FR2-A3-10
Subcarrier spacing (kHz)	60	60	120	120	120
Allocated resource blocks	66	132	32	66	132
CP-OFDM Symbols per slot (Note 1)	9	9	9	9	9
Modulation	QPSK	QPSK	QPSK	QPSK	QPSK
Code rate (Note 2)	193/1024	193/1024	193/1024	193/1024	193/1024
Payload size (bits)	5384	10752	2600	5384	10752
Transport block CRC (bits)	24	24	16	24	24
Code block CRC size (bits)	24	24	-	24	24
Number of code blocks - C	2	3	1	2	3
Code block size including CRC (bits) (Note 2)	2728	3616	2616	2728	3616
Total number of bits per slot	28512	57024	13824	28512	57024
Total symbols per slot	14256	28512	6912	14256	28512
NOTE 1: DM-RS configuration type = 1 with DM-RS duration = single-symbol DM-RS and the number of DM-RS CDM groups without data is 2, additional DM-RS position = pos0 with $l_0 = 0$ as per table 6.4.1.1.3-3 of TS 38.211 [20].					
NOTE 2: Code block size including CRC (bits) equals to $K'$ in clause 5.2.2 of TS 38.212 [19].					

**Table A.3-9: FRC parameters for FR2 PUSCH performance requirements, transform precoding enabled, additional DM-RS position = pos0 and 1 transmission layer (QPSK, R=193/1024)**

Reference channel	G-FR2-A3-11	G-FR2-A3-12
Subcarrier spacing (kHz)	60	120
Allocated resource blocks	30	30
DFT-s-OFDM Symbols per slot (Note 1)	9	9
Modulation	QPSK	QPSK
Code rate (Note 2)	193/1024	193/1024
Payload size (bits)	1224	1224
Transport block CRC (bits)	16	16
Code block CRC size (bits)	-	-
Number of code blocks - C	1	1
Code block size including CRC (bits) (Note 2)	1240	1240
Total number of bits per slot	6480	6480
Total symbols per slot	3240	3240
NOTE 1: DM-RS configuration type = 1 with DM-RS duration = single-symbol DM-RS and the number of DM-RS CDM groups without data is 2, additional DM-RS position = pos0 with $l_0 = 0$ as per table 6.4.1.1.3-3 of TS 38.211 [20].		
NOTE 2: Code block size including CRC (bits) equals to $K'$ in clause 5.2.2 of TS 38.212 [19].		

**Table A.3-10: FRC parameters for FR2 PUSCH performance requirements, transform precoding disabled, additional DM-RS position = pos1 and 1 transmission layer (QPSK, R=193/1024)**

Reference channel	G-FR2-A3-13	G-FR2-A3-14	G-FR2-A3-15	G-FR2-A3-16	G-FR2-A3-17
Subcarrier spacing (kHz)	60	60	120	120	120
Allocated resource blocks	66	132	32	66	132
CP-OFDM Symbols per slot (Note 1)	8	8	8	8	8
Modulation	QPSK	QPSK	QPSK	QPSK	QPSK
Code rate (Note 2)	193/1024	193/1024	193/1024	193/1024	193/1024
Payload size (bits)	2408	4744	1160	2408	4744
Transport block CRC (bits)	16	24	16	16	24
Code block CRC size (bits)	-	24	-	-	24
Number of code blocks - C	1	2	1	1	2
Code block size including CRC (bits) (Note 2)	2424	2408	1176	2424	2408
Total number of bits per slot	12672	25344	6144	12672	25344
Total symbols per slot	6336	12672	3072	6336	12672
NOTE 1: DM-RS configuration type = 1 with DM-RS duration = single-symbol DM-RS and the number of DM-RS CDM groups without data is 2, additional DM-RS position = pos1 with $l_0 = 0$ and $l = 8$ as per table 6.4.1.1.3-3 of TS 38.211 [20].					
NOTE 2: Code block size including CRC (bits) equals to $K'$ in clause 5.2.2 of TS 38.212 [19].					

**Table A.3-11: FRC parameters for FR2 PUSCH performance requirements, transform precoding disabled, additional DM-RS position = pos1 and 2 transmission layers (QPSK, R=193/1024)**

Reference channel	G-FR2-A3-18	G-FR2-A3-19	G-FR2-A3-20	G-FR2-A3-21	G-FR2-A3-22
Subcarrier spacing (kHz)	60	60	120	120	120
Allocated resource blocks	66	132	32	66	132
CP-OFDM Symbols per slot (Note 1)	8	8	8	8	8
Modulation	QPSK	QPSK	QPSK	QPSK	QPSK
Code rate (Note 2)	193/1024	193/1024	193/1024	193/1024	193/1024
Payload size (bits)	4744	9480	2408	4744	9480
Transport block CRC (bits)	24	24	16	24	24
Code block CRC size (bits)	24	24	-	24	24
Number of code blocks - C	2	3	1	2	3
Code block size including CRC (bits) (Note 2)	2408	3192	2424	2408	3192
Total number of bits per slot	25344	50688	12288	25344	50688
Total symbols per slot	12672	25344	6144	12672	25344
NOTE 1: DM-RS configuration type = 1 with DM-RS duration = single-symbol DM-RS and the number of DM-RS CDM groups without data is 2, additional DM-RS position = pos1 with $l_0 = 0$ and $l = 8$ as per table 6.4.1.1.3-3 of TS 38.211 [20].					
NOTE 2: Code block size including CRC (bits) equals to $K'$ in clause 5.2.2 of TS 38.212 [19].					

**Table A.3-12: FRC parameters for FR2 PUSCH performance requirements, transform precoding enabled, additional DM-RS position = pos1 and 1 transmission layer (QPSK, R=193/1024)**

Reference channel	G-FR2-A3-23	G-FR2-A3-24
Subcarrier spacing (kHz)	60	120
Allocated resource blocks	30	30
DFT-s-OFDM Symbols per slot (Note 1)	8	8
Modulation	QPSK	QPSK
Code rate (Note 2)	193/1024	193/1024
Payload size (bits)	1128	1128
Transport block CRC (bits)	16	16
Code block CRC size (bits)	-	-
Number of code blocks - C	1	1
Code block size including CRC (bits) (Note 2)	1144	1144
Total number of bits per slot	5760	5760
Total symbols per slot	2880	2880
NOTE 1: DM-RS configuration type = 1 with DM-RS duration = single-symbol DM-RS and the number of DM-RS CDM groups without data is 2, additional DM-RS position = pos1 with $l_0 = 0$ and $l = 8$ as per table 6.4.1.1.3-3 of TS 38.211 [20].		
NOTE 2: Code block size including CRC (bits) equals to $K'$ in clause 5.2.2 of TS 38.212 [19].		

**Table A.3-13: FRC parameters for FR2 PUSCH performance requirements, transform precoding disabled, additional DM-RS position = pos1 and 1 transmission layer (QPSK, R=193/1024)**

Reference channel	G-FR2-A3-25	G-FR2-A3-26
Subcarrier spacing (kHz)	60	120
Allocated resource blocks	2	2
CP-OFDM Symbols per slot (Note 1)	8	8
Modulation	QPSK	QPSK
Code rate (Note 2)	193/1024	193/1024
Payload size (bits)	72	72
Transport block CRC (bits)	16	16
Code block CRC size (bits)	0	0
Number of code blocks - C	1	1
Code block size including CRC (bits) (Note 2)	88	88
Total number of bits per slot	384	384
Total symbols per slot	192	192
NOTE 1: DM-RS configuration type = 1 with DM-RS duration = single-symbol DM-RS and the number of DM-RS CDM groups without data is 2, Additional DM-RS position = pos1 with $l_0=2$ and $l=10$ as per Table 6.4.1.1.3-3 of TS 38.211 [20].		
NOTE 2: Code block size including CRC (bits) equals to $K'$ in clause 5.2.2 of TS 38.212 [19].		

**Table A.3-14: FRC parameters for FR1 PUSCH performance requirements, transform precoding disabled, Additional DM-RS position = pos1 and 1 transmission layer (QPSK, R=193/1024)**

Reference channel	G-FR1-A3-35	G-FR1-A3-36	G-FR1-A3-37	G-FR1-A3-38
Number of TBoMS slots	2	4	2	4
Subcarrier spacing [kHz]	15	15	30	30
Allocated resource blocks per slot	5	5	5	5
Data bearing CP-OFDM Symbols per slot (Note 1)	12	12	12	12
Modulation	QPSK	QPSK	QPSK	QPSK
Code rate (Note 2)	193/1024	193/1024	193/1024	193/1024
Payload size (bits)	552	1128	552	1128
Transport block CRC (bits)	16	16	16	16
Code block CRC size (bits)	-	-	-	-
Number of code blocks - C	1	1	1	1
Code block size including CRC (bits) (Note 2)	568	1144	568	1144
Total number of bits over all TBoMS slots	2880	5760	2880	5760
Total resource elements over all TBoMS slots	1440	2880	1440	2880
NOTE 1: DM-RS configuration type = 1 with DM-RS duration = single-symbol DM-RS and the number of DM-RS CDM groups without data is 2, additional DM-RS position = pos1, $l_0=2$ and $l=11$ for PUSCH mapping type A, $l_0=0$ and $l=10$ for PUSCH mapping type B as per table 6.4.1.1.3-3 of TS 38.211 [20].				
NOTE 2: Code block size including CRC (bits) equals to $K'$ in sub-clause 5.2.2 of TS 38.212 [19].				

**Table A.3-15: FRC parameters for FR2 PUSCH performance requirements, transform precoding disabled, Additional DM-RS position = pos1 and 1 transmission layer (QPSK, R=193/1024)**

Reference channel	G-FR2-A3-27	G-FR2-A3-28
Number of TBoMS slots	2	2
Subcarrier spacing [kHz]	60	120
Allocated resource blocks per slot	5	5
Data bearing CP-OFDM Symbols per slot (Note 1)	8	8
Modulation	QPSK	QPSK
Code rate (Note 2)	193/1024	193/1024
Payload size (bits)	368	368
Transport block CRC (bits)	16	16
Code block CRC size (bits)	-	-
Number of code blocks - C	1	1
Code block size including CRC (bits) (Note 2)	384	384
Total number of bits over all TBoMS slots	1920	1920
Total resource elements over all TBoMS slots	960	960
NOTE 1: DM-RS configuration type = 1 with DM-RS duration = single-symbol DM-RS and the number of DM-RS CDM groups without data is 2, additional DM-RS position = pos1, $l_0 = 0$ and $l = 8$ for PUSCH mapping type B as per table 6.4.1.1.3-3 of TS 38.211 [20].		
NOTE 2: Code block size including CRC (bits) equals to K' in sub-clause 5.2.2 of TS 38.212 [19].		

## A.3A Fixed Reference Channels for performance requirements (QPSK, R=99/1024)

The parameters for the reference measurement channels are specified in table A.3A-1 for FR1 PUSCH performance requirements:

- FRC parameters are specified in table A.3A-1 for FR1 PUSCH with transform precoding disabled, additional DM-RS position = pos1 and 1 transmission layer.

The parameters for the reference measurement channels are specified in table A.3A-2 to A.3A-3 for FR2 PUSCH performance requirements:

- FRC parameters are specified in table A.3A-2 for FR2 PUSCH with transform precoding disabled, additional DM-RS position = pos0 and 1 transmission layer.
- FRC parameters are specified in table A.3A-3 for FR2 PUSCH with transform precoding disabled, additional DM-RS position = pos1 and 1 transmission layer.

**Table A.3A-1: FRC parameters for FR1 PUSCH performance requirements, transform precoding disabled, additional DM-RS position = pos1 and 1 transmission layer (QPSK, R=99/1024)**

Reference channel	G-FR1-A3A-1	G-FR1-A3A-2	G-FR1-A3A-3	G-FR1-A3A-4
Subcarrier spacing [kHz]	15	15	30	30
Allocated resource blocks	25	52	24	106
CP-OFDM Symbols per slot (Note 1)	12	12	12	12
Modulation	QPSK	QPSK	QPSK	QPSK
Code rate (Note 2)	99/1024	99/1024	99/1024	99/1024
Payload size (bits)	704	1480	672	2976
Transport block CRC (bits)	16	16	16	16
Code block CRC size (bits)	-	-	-	-
Number of code blocks - C	1	1	1	1
Code block size including CRC (bits) (Note 2)	720	1496	688	2992
Total number of bits per slot	7200	14976	6912	30528
Total symbols per slot	3600	7488	3456	15264
NOTE 1: DM-RS configuration type = 1 with DM-RS duration = single-symbol DM-RS and the number of DM-RS CDM groups without data is 2, additional DM-RS position = pos1, $l_0 = 2$ and $l = 11$ for PUSCH mapping type A, $l_0 = 0$ and $l = 10$ for PUSCH mapping type B as per table 6.4.1.1.3-3 of TS 38.211 [20].				
NOTE 2: Code block size including CRC (bits) equals to $K'$ in clause 5.2.2 of TS 38.212 [19].				

**Table A.3A-2: FRC parameters for FR2 PUSCH performance requirements, transform precoding disabled, additional DM-RS position = pos0 and 1 transmission layer (QPSK, R=99/1024)**

Reference channel	G-FR2-A3A-1	G-FR2-A3A-2	G-FR2-A3A-3	G-FR2-A3A-4
Subcarrier spacing [kHz]	60	60	120	120
Allocated resource blocks	66	132	32	66
Data bearing CP-OFDM Symbols per slot (Note 1)	3	3	3	3
Modulation	QPSK	QPSK	QPSK	QPSK
Code rate (Note 2)	99/1024	99/1024	99/1024	99/1024
Payload size (bits)	456	928	224	456
Transport block CRC (bits)	16	16	16	16
Code block CRC size (bits)	-	-	-	-
Number of code blocks - C	1	1	1	1
Code block size including CRC (bits) (Note 2)	472	944	240	472
Total number of bits per slot	4752	9504	2304	4752
Total symbols per slot	2376	4752	1152	2376
NOTE 1: DM-RS configuration type = 1 with DM-RS duration = single-symbol DM-RS and the number of DM-RS CDM groups without data is 2, additional DM-RS position = pos0, $l_0 = 0$ as per table 6.4.1.1.3-3 of TS 38.211 [20].				
NOTE 2: Code block size including CRC (bits) equals to $K'$ in subclause 5.2.2 of TS 38.212 [19].				

**Table A.3A-3: FRC parameters for FR2 PUSCH performance requirements, transform precoding disabled, additional DM-RS position = pos1 and 1 transmission layer (QPSK, R=99/1024)**

Reference channel	G-FR2-A3A-5	G-FR2-A3A-6	G-FR2-A3A-7	G-FR2-A3A-8
Subcarrier spacing [kHz]	60	60	120	120
Allocated resource blocks	66	132	32	66
Data bearing CP-OFDM Symbols per slot (Note 1)	8	8	8	8
Modulation	QPSK	QPSK	QPSK	QPSK
Code rate (Note 2)	99/1024	99/1024	99/1024	99/1024
Payload size (bits)	1224	2472	608	1224
Transport block CRC (bits)	16	16	16	16
Code block CRC size (bits)	-	-	-	-
Number of code blocks - C	1	1	1	1
Code block size including CRC (bits) (Note 2)	1240	2488	624	1240
Total number of bits per slot	12672	25344	6144	12672
Total symbols per slot	6336	12672	3072	6336
NOTE 1: DM-RS configuration type = 1 with DM-RS duration = single-symbol DM-RS and the number of DM-RS CDM groups without data is 2, additional DM-RS position = pos1, $l_0=0$ and $l=8$ as per table 6.4.1.1.3-3 of TS 38.211 [20].				
NOTE 2: Code block size including CRC (bits) equals to $K'$ in subclause 5.2.2 of TS 38.212 [19].				

## A.3B Fixed Reference Channels for performance requirements (QPSK, R=308/1024)

The parameters for the reference measurement channels are specified in table A.3B-1 for FR1 PUSCH performance requirements:

- FRC parameters are specified in table A.3B-1 for FR1 PUSCH with transform precoding disabled, no additional DM-RS and 1 transmission layer.

The parameters for the reference measurement channel are specified in table A.3B-2 and table A.3B-3 for FR1 PUSCH performance requirements with DM-RS bundling:

- FRC parameters are specified in table A.3B-2 for FR1 PUSCH with transform precoding disabled, additional DM-RS position = pos1 and 1 transmission layer.
- FRC parameters are specified in table A.3B-3 for FR1 PUSCH with transform precoding disabled, additional DM-RS position = pos0 and 1 transmission layer.

The parameters for the reference measurement channel are specified in table A.3B-4 for FR2 PUSCH performance requirements with DM-RS bundling:

- FRC parameters are specified in table A.3B-4 for FR2 PUSCH with transform precoding disabled, additional DM-RS position = pos1 and 1 transmission layer.

The parameters for the reference measurement channel are specified in table A.3B-5 to table A.3B-7 for FR2-2 PUSCH performance requirements:

- FRC parameters are specified in table A.3B-5 for FR2-2 PUSCH with transform precoding disabled, *Additional DM-RS position = pos1* and 1 transmission layer.
- FRC parameters are specified in table A.3B-6 for FR2-2 PUSCH with transform precoding enabled, *Additional DM-RS position = pos1* and 1 transmission layer.
- FRC parameters are specified in table A.3B-7 for FR2-2 PUSCH with transform precoding disabled, *Additional DM-RS position = pos1* and 2 transmission layers.

**Table A.3B-1: FRC parameters for FR1 PUSCH performance requirements, transform precoding disabled, no additional DM-RS and 1 transmission layer (QPSK, R=308/1024)**

Reference channel	G-FR1-A3B-1	G-FR1-A3B-2	G-FR1-A3B-3	G-FR1-A3B-4
Subcarrier spacing [kHz]	15	15	30	30
Allocated resource blocks	25	52	24	106
CP-OFDM Symbols per slot (Note 1)	1	1	1	1
Modulation	QPSK	QPSK	QPSK	QPSK
Code rate (Note 2)	308/1024	308/1024	308/1024	308/1024
Payload size (bits)	176	368	168	768
Transport block CRC (bits)	16	16	16	16
Code block CRC size (bits)	-	-	-	-
Number of code blocks - C	1	1	1	1
Code block size including CRC (bits) (Note 2)	192	384	184	784
Total number of bits per slot	600	1248	576	2544
Total symbols per slot	300	624	288	1272
NOTE 1: DM-RS configuration type = 1 with DM-RS duration = single-symbol DM-RS and the number of DM-RS CDM groups without data is 2, additional DM-RS position = pos0, $l_0 = 0$ as per table 6.4.1.1.3-3 of TS 38.211 [20].				
NOTE 2: Code block size including CRC (bits) equals to $K'$ in clause 5.2.2 of TS 38.212 [19].				

**Table A.3B-2: FRC parameters for FR1 PUSCH performance requirements, transform precoding disabled, Additional DM-RS position = pos1 and 1 transmission layer (QPSK, R=308/1024)**

Reference channel	G-FR1-A3B-5	G-FR1-A3B-6
Subcarrier spacing [kHz]	15	30
Allocated resource blocks	25	24
CP-OFDM Symbols per slot (Note 1)	12	12
Modulation	QPSK	QPSK
Code rate (Note 2)	308/1024	308/1024
Payload size (bits)	2152	2088
Transport block CRC (bits)	16	16
Code block CRC size (bits)	-	-
Number of code blocks - C	1	1
Code block size including CRC (bits) (Note 2)	2168	2104
Total number of bits per slot	7200	6912
Total resource elements per slot	3600	3456
NOTE 1: DM-RS configuration type = 1 with DM-RS duration = single-symbol DM-RS and the number of DM-RS CDM groups without data is 2, Additional DM-RS position = pos1, $l_0 = 2$ and $l = 11$ for PUSCH mapping type A, $l_0 = 0$ and $l = 10$ for PUSCH mapping type B as per Table 6.4.1.1.3-3 of TS 38.211 [9].		
NOTE 2: Code block size including CRC (bits) equals to $K'$ in sub-clause 5.2.2 of TS 38.212 [15].		



**Table A.3B-3: FRC parameters for FR1 PUSCH performance requirements, transform precoding disabled, *Additional DM-RS position = pos0* and 1 transmission layer (QPSK, R=308/1024)**

Reference channel	G-FR1-A3B-7	G-FR1-A3B-8
Subcarrier spacing [kHz]	15	30
Allocated resource blocks	25	24
CP-OFDM Symbols per slot (Note 1)	13	13
Modulation	QPSK	QPSK
Code rate (Note 2)	308/1024	308/1024
Payload size (bits)	2408	2280
Transport block CRC (bits)	16	16
Code block CRC size (bits)	-	-
Number of code blocks - C	1	1
Code block size including CRC (bits) (Note 2)	2424	2296
Total number of bits per slot	7800	7488
Total resource elements per slot	3900	3744
NOTE 1: <i>DM-RS configuration type = 1</i> with <i>DM-RS duration = single-symbol DM-RS</i> and the number of DM-RS CDM groups without data is 2, <i>Additional DM-RS position = pos0</i> $l_0 = 2$ and $l = 11$ for PUSCH mapping type A, $l_0 = 0$ and $l = 10$ for PUSCH mapping type B as per table 6.4.1.1.3-3 of TS 38.211 [9].		
NOTE 2: Code block size including CRC (bits) equals to $K'$ in sub-clause 5.2.2 of TS 38.212 [15].		

**Table A.3B-4: FRC parameters for FR2 PUSCH performance requirements, transform precoding disabled, *Additional DM-RS position = pos1* and 1 transmission layer (QPSK, R=308/1024)**

Reference channel	G-FR2-A3B-1	G-FR2-A3B-2
Subcarrier spacing [kHz]	60	120
Allocated resource blocks	66	32
CP-OFDM Symbols per slot (Note 1)	12	12
Modulation	QPSK	QPSK
Code rate (Note 2)	308/1024	308/1024
Payload size (bits)	5632	2792
Transport block CRC (bits)	24	16
Code block CRC size (bits)	-	-
Number of code blocks - C	1	1
Code block size including CRC (bits) (Note 2)	5656	2808
Total number of bits per slot	19008	9216
Total resource elements per slot	9504	4608
NOTE 1: <i>DM-RS configuration type = 1</i> with <i>DM-RS duration = single-symbol DM-RS</i> and the number of DM-RS CDM groups without data is 2, <i>Additional DM-RS position = pos1</i> with $l_0 = 0$ and $l = 10$ as per Table 6.4.1.1.3-3 of TS 38.211 [9].		
NOTE 2: Code block size including CRC (bits) equals to $K'$ in sub-clause 5.2.2 of TS 38.212 [15].		

**Table A.3B-5: FRC parameters for FR2-2 PUSCH performance requirements, transform precoding disabled, *Additional DM-RS position = pos1* and 1 transmission layer (QPSK, R=308/1024)**

Reference channel	G-FR2-A3B-3	G-FR2-A3B-4	G-FR2-A3B-5
Subcarrier spacing [kHz]	120	120	480
Allocated resource blocks	66	264	66
CP-OFDM Symbols per slot (Note 1)	8	8	8
Modulation	QPSK	QPSK	QPSK
Code rate (Note 2)	308/1024	308/1024	308/1024
Payload size (bits)	3824	15112	3824
Transport block CRC (bits)	16	24	16
Code block CRC size (bits)	-	24	-
Number of code blocks - C	1	2	1
Code block size including CRC (bits) (Note 2)	3840	7592	3840
Total number of bits per slot without PT-RS	12672	50688	12672
Total symbols per slot without PT-RS	6336	25344	6336
NOTE 1: <i>DM-RS configuration type = 1</i> with <i>DM-RS duration = single-symbol DM-RS</i> and the number of DM-RS CDM groups without data is 2, <i>Additional DM-RS position = pos1</i> with $l_0 = 0$ and $l = 8$ as per Table 6.4.1.1.3-3 of TS 38.211 [9].			
NOTE 2: Code block size including CRC (bits) equals to $K'$ in sub-clause 5.2.2 of TS 38.212 [15].			
NOTE 3: The calculation of the "Total number of bits per slot" and "Total symbols per slot" fields include the REs taken up by CSI part 1 and CSI part 2, if present.			

**Table A.3B-6: FRC parameters for FR2-2 PUSCH performance requirements, transform precoding enabled, *Additional DM-RS position = pos1* and 1 transmission layer (QPSK, R=308/1024)**

Reference channel	G-FR2-A3B-6	G-FR2-A3B-7
Subcarrier spacing [kHz]	120	480
Allocated resource blocks	64	64
DFT-s-OFDM Symbols per slot (Note 1)	8	8
Modulation	QPSK	QPSK
Code rate (Note 2)	308/1024	308/1024
Payload size (bits)	3624	3624
Transport block CRC (bits)	16	16
Code block CRC size (bits)	-	-
Number of code blocks - C	1	1
Code block size including CRC (bits) (Note 2)	3640	3640
Total number of bits per slot without PT-RS	12288	12288
Total symbols per slot without PT-RS	6144	6144
NOTE 1: <i>DM-RS configuration type = 1</i> with <i>DM-RS duration = single-symbol DM-RS</i> and the number of DM-RS CDM groups without data is 2, <i>Additional DM-RS position = pos1</i> with $l_0 = 0$ and $l = 8$ as per Table 6.4.1.1.3-3 of TS 38.211 [9].		
NOTE 2: Code block size including CRC (bits) equals to $K'$ in sub-clause 5.2.2 of TS 38.212 [15].		
NOTE 3: The calculation of the "Total number of bits per slot" and "Total symbols per slot" fields include the REs taken up by CSI part 1 and CSI part 2, if present.		

**Table A.3B-7: FRC parameters for FR2-2 PUSCH performance requirements, transform precoding disabled, *Additional DM-RS position = pos1 and 2* transmission layers (QPSK, R=308/1024)**

Reference channel	G-FR2-A3B-8	G-FR2-A3B-9	G-FR2-A3B-10
Subcarrier spacing [kHz]	120	120	480
Allocated resource blocks	66	264	66
CP-OFDM Symbols per slot (Note 1)	8	8	8
Modulation	QPSK	QPSK	QPSK
Code rate (Note 2)	308/1024	308/1024	308/1024
Payload size (bits)	7552	30728	7552
Transport block CRC (bits)	24	24	24
Code block CRC size (bits)	-	24	-
Number of code blocks - C	1	4	1
Code block size including CRC (bits) (Note 2)	7576	7712	7576
Total number of bits per slot without PT-RS	25344	101376	25344
Total symbols per slot without PT-RS	12672	50688	12672
NOTE 1: <i>DM-RS configuration type = 1</i> with <i>DM-RS duration = single-symbol DM-RS</i> and the number of DM-RS CDM groups without data is 2, <i>Additional DM-RS position = pos1</i> with $l_0 = 0$ and $l = 8$ as per Table 6.4.1.1.3-3 of TS 38.211 [9].			
NOTE 2: Code block size including CRC (bits) equals to $K'$ in sub-clause 5.2.2 of TS 38.212 [15].			
NOTE 3: The calculation of the "Total number of bits per slot" and "Total symbols per slot" fields include the REs taken up by CSI part 1 and CSI part 2, if present.			

## A.4 Fixed Reference Channels for performance requirements (16QAM, R=658/1024)

The parameters for the reference measurement channels are specified in table A.4-2, table A.4-2A, table A.4-2B and table A.4-4 for FR1 PUSCH performance requirements:

- FRC parameters are specified in table A.4-2 for FR1 PUSCH with transform precoding disabled, additional DM-RS position = pos1 and 1 transmission layer.
- FRC parameters are specified in table A.4-2A for FR1 PUSCH with transform precoding disabled, additional DM-RS position = pos 2 and 1 transmission layer.
- FRC parameters are specified in table A.4-2B for FR1 UL timing adjustment, PUSCH with transform precoding disabled, additional DM-RS position = pos2 and 1 transmission layer.
- FRC parameters are specified in table A.4-4 for FR1 PUSCH with transform precoding disabled, additional DM-RS position = pos1 and 2 transmission layers.

The parameters for the reference measurement channels are specified in table A.4-5 to table A.4-8 for FR2-1 PUSCH performance requirements:

- FRC parameters are specified in table A.4-5 for FR2-1 PUSCH with transform precoding disabled, additional DM-RS position = pos0 and 1 transmission layer.
- FRC parameters are specified in table A.4-6 for FR2-1 PUSCH with transform precoding disabled, additional DM-RS position = pos0 and 2 transmission layers.
- FRC parameters are specified in table A.4-7 for FR2-1 PUSCH with transform precoding disabled, additional DM-RS position = pos1 and 1 transmission layer.
- FRC parameters are specified in table A.4-8 for FR2-1 PUSCH with transform precoding disabled, additional DM-RS position = pos1 and 2 transmission layers.

The parameters for the reference measurement channels are specified in table A.4-7A for FR2-2 PUSCH performance requirements:

- FRC parameters are specified in table A.4-7A for FR2-2 PUSCH with transform precoding disabled, additional DM-RS position = pos1 and 1 transmission layer.

Table A.4-1: Void

Table A.4-2: FRC parameters for FR1 PUSCH performance requirements, transform precoding disabled, additional DM-RS position = pos1 and 1 transmission layer (16QAM, R=658/1024)

Reference channel	G-FR1-A4-8	G-FR1-A4-9	G-FR1-A4-10	G-FR1-A4-11(Note 3)	G-FR1-A4-12	G-FR1-A4-13	G-FR1-A4-14
Subcarrier spacing (kHz)	15	15	15	30	30	30	30
Allocated resource blocks	25	52	106	24	51	106	273
CP-OFDM Symbols per slot (Note 1)	12	12	12	12	12	12	12
Modulation	16QAM	16QAM	16QAM	16QAM	16QAM	16QAM	16QAM
Code rate (Note 2)	658/1024	658/1024	658/1024	658/1024	658/1024	658/1024	658/1024
Payload size (bits)	9224	19464	38936	8968	18960	38936	100392
Transport block CRC (bits)	24	24	24	24	24	24	24
Code block CRC size (bits)	24	24	24	24	24	24	24
Number of code blocks - C	2	3	5	2	3	5	12
Code block size including CRC (bits) (Note 2)	4648	6520	7816	4520	6352	7816	8392
Total number of bits per slot	14400	29952	61056	13824	29376	61056	157248
Total symbols per slot	3600	7488	15264	3456	7344	15264	39312
NOTE 1: DM-RS configuration type = 1 with DM-RS duration = single-symbol DM-RS and the number of DM-RS CDM groups without data is 2, Additional DM-RS position = pos1, $l_0=2$ and $l=11$ for PUSCH mapping type A, $l_0=0$ and $l=10$ for PUSCH mapping type B as per table 6.4.1.1.3-3 of TS 38.211 [20].							
NOTE 2: Code block size including CRC (bits) equals to $K'$ in clause 5.2.2 of TS 38.212 [19].							
NOTE 3: The calculation of the "Total number of bits per slot" and "Total symbols per slot" fields include the REs taken up by CSI part 1 and CSI part 2, if present.							

Table A.4-2A: FRC parameters for FR1 PUSCH performance requirements, transform precoding disabled, Additional DM-RS position = pos2 and 1 transmission layer (16QAM, R=658/1024)

Reference channel	G-FR1-A4-29	G-FR1-A4-29A	G-FR1-A4-30	G-FR1-A4-30A
Subcarrier spacing [kHz]	15	15	30	30
Allocated resource blocks	52	25	106	24
Data bearing CP-OFDM Symbols per slot (Note 1)	11	11	11	11
Modulation	16QAM	16QAM	16QAM	16QAM
Code rate (Note 2)	658/1024	658/1024	658/1024	658/1024
Payload size (bits)	17424	8456	35856	8064
Transport block CRC (bits)	24	24	24	24
Code block CRC size (bits)	24	24	24	-
Number of code blocks - C	3	2	5	1
Code block size including CRC (bits) (Note 2)	5840	4264	7200	8088
Total number of bits per slot	27456	13200	55968	12672
Total resource elements per slot	6846	3300	13992	3168
NOTE 1: DM-RS configuration type = 1 with DM-RS duration = single-symbol DM-RS and the number of DM-RS CDM groups without data is 2, Additional DM-RS position = pos2, and $l_0=2$ or 3 for PUSCH mapping type A, as per table 6.4.1.1.3-3 of TS 38.211 [20].				
NOTE 2: Code block size including CRC (bits) equals to $K'$ in clause 5.2.2 of TS 38.212 [19].				

**Table A.4-2B: FRC parameters for FR1 UL timing adjustment, PUSCH with transform precoding disabled, Additional DM-RS position = pos2 and 1 transmission layer (16QAM, R=658/1024)**

Reference channel	G-FR1-A4-31A	G-FR1-A4-31	G-FR1-A4-32A	G-FR1-A4-32
Subcarrier spacing [kHz]	15	15	30	30
Allocated resource blocks	12	25	12	50
Data bearing CP-OFDM Symbols per slot (Note 1)	11	11	11	11
Modulation	16QAM	16QAM	16QAM	16QAM
Code rate (Note 2)	658/1024	658/1024	658/1024	658/1024
Payload size (bits)	4032	8456	4032	16896
Transport block CRC (bits)	24	24	24	24
Code block CRC size (bits)	-	24	-	24
Number of code blocks - C	1	2	1	3
Code block size including CRC (bits) (Note 2)	4056	4264	4056	5664
Total number of bits per slot	6336	13200	6336	26400
Total data bearing resource elements per slot	1584	3300	1584	6600
NOTE 1: DM-RS configuration type = 1 with DM-RS duration = single-symbol DM-RS and the number of DM-RS CDM groups without data is 2, Additional DM-RS position = pos2, and $l_0 = 2$ for PUSCH mapping type A, $l_0 = 0$ for PUSCH mapping type B, as per table 6.4.1.1.3-3 of TS 38.211 [20].				
NOTE 2: Code block size including CRC (bits) equals to $K'$ in clause 5.2.2 of TS 38.212 [19].				

**Table A.4-3: Void****Table A.4-4: FRC parameters for FR1 PUSCH performance requirements, transform precoding disabled, additional DM-RS position = pos1 and 2 transmission layers (16QAM, R=658/1024)**

Reference channel	G-FR1-A4-22	G-FR1-A4-23	G-FR1-A4-24	G-FR1-A4-25	G-FR1-A4-26	G-FR1-A4-27	G-FR1-A4-28
Subcarrier spacing (kHz)	15	15	15	30	30	30	30
Allocated resource blocks	25	52	106	24	51	106	273
CP-OFDM Symbols per slot (Note 1)	12	12	12	12	12	12	12
Modulation	16QAM	16QAM	16QAM	16QAM	16QAM	16QAM	16QAM
Code rate (Note 2)	658/1024	658/1024	658/1024	658/1024	658/1024	658/1024	658/1024
Payload size (bits)	18432	38936	77896	17928	37896	77896	200808
Transport block CRC (bits)	24	24	24	24	24	24	24
Code block CRC size (bits)	24	24	24	24	24	24	24
Number of code blocks - C	3	5	10	3	5	10	24
Code block size including CRC (bits) (Note 2)	6176	7816	7816	6008	7608	7816	8392
Total number of bits per slot	28800	59904	122112	27648	58752	122112	314496
Total symbols per slot	7200	14976	30528	6912	14688	30528	78624
NOTE 1: DM-RS configuration type = 1 with DM-RS duration = single-symbol DM-RS and the number of DM-RS CDM groups without data is 2, additional DM-RS position = pos1, $l_0 = 2$ and $l = 11$ for PUSCH mapping type A, $l_0 = 0$ and $l = 10$ for PUSCH mapping type B as per table 6.4.1.1.3-3 of TS 38.211 [20].							
NOTE 2: Code block size including CRC (bits) equals to $K'$ in clause 5.2.2 of TS 38.212 [19].							

**Table A.4-5: FRC parameters for FR2-1 PUSCH performance requirements, transform precoding disabled, additional DM-RS position = pos0 and 1 transmission layer (16QAM, R=658/1024)**

Reference channel	G-FR2-A4-1	G-FR2-A4-2	G-FR2-A4-3(Note 3)	G-FR2-A4-4	G-FR2-A4-5
Subcarrier spacing (kHz)	60	60	120	120	120
Allocated resource blocks	66	132	32	66	132
CP-OFDM Symbols per slot (Note 1)	9	9	9	9	9
Modulation	16QAM	16QAM	16QAM	16QAM	16QAM
Code rate (Note 2)	658/1024	658/1024	658/1024	658/1024	658/1024
Payload size (bits)	18432	36896	8968	18432	36896
Transport block CRC (bits)	24	24	24	24	24
Code block CRC size (bits)	24	24	24	24	24
Number of code blocks - C	3	5	2	3	5
Code block size including CRC (bits) (Note 2)	6176	7408	4520	6176	7408
Total number of bits per slot without PT-RS	28512	57024	13824	28512	57024
Total number of bits per slot with PT-RS (Note 4)	27324	54648	13248	27324	54648
Total symbols per slot without PT-RS	7128	14256	3456	7128	14256
Total symbols per slot with PT-RS (Note 4)	6831	13662	3312	6831	13662
NOTE 1: DM-RS configuration type = 1 with DM-RS duration = single-symbol DM-RS and the number of DM-RS CDM groups without data is 2, additional DM-RS position = pos0 with $l_0=0$ as per table 6.4.1.1.3-3 of TS 38.211 [20].					
NOTE 2: Code block size including CRC (bits) equals to $K'$ in clause 5.2.2 of TS 38.212 [15].					
NOTE 3: The calculation of the "Total number of bits per slot" and "Total symbols per slot" fields include the REs taken up by CSI part 1 and CSI part 2, if present.					
NOTE 4: PT-RS configuration $K_{PT-RS}=2, L_{PT-RS}=1$ .					

**Table A.4-6: FRC parameters for FR2-1 PUSCH performance requirements, transform precoding disabled, additional DM-RS position = pos0 and 2 transmission layers (16QAM, R=658/1024)**

Reference channel	G-FR2-A4-6	G-FR2-A4-7	G-FR2-A4-8	G-FR2-A4-9	G-FR2-A4-10
Subcarrier spacing (kHz)	60	60	120	120	120
Allocated resource blocks	66	132	32	66	132
CP-OFDM Symbols per slot (Note 1)	9	9	9	9	9
Modulation	16QAM	16QAM	16QAM	16QAM	16QAM
Code rate (Note 2)	658/1024	658/1024	658/1024	658/1024	658/1024
Payload size (bits)	36896	73776	17928	36896	73776
Transport block CRC (bits)	24	24	24	24	24
Code block CRC size (bits)	24	24	24	24	24
Number of code blocks - C	5	9	3	5	9
Code block size including CRC (bits) (Note 2)	7408	8224	6008	7408	8224
Total number of bits per slot without PT-RS	57024	114048	27648	57024	114048
Total number of bits per slot with PT-RS (Note 3)	54648	109296	26496	54648	109296
Total symbols per slot without PT-RS	14256	28512	6912	14256	28512
Total symbols per slot with PT-RS (Note 3)	13662	27324	6624	13662	27324
NOTE 1: DM-RS configuration type = 1 with DM-RS duration = single-symbol DM-RS and the number of DM-RS CDM groups without data is 2, additional DM-RS position = pos0 with $l_0=0$ as per table 6.4.1.1.3-3 of TS 38.211 [20].					
NOTE 2: Code block size including CRC (bits) equals to $K'$ in clause 5.2.2 of TS 38.212 [15].					
NOTE 3: PT-RS configuration $K_{PT-RS}=2, L_{PT-RS}=1$ .					

**Table A.4-7: FRC parameters for FR2-1 PUSCH performance requirements, transform precoding disabled, additional DM-RS position = pos1 and 1 transmission layer (16QAM, R=658/1024)**

Reference channel	G-FR2-A4-11	G-FR2-A4-12	G-FR2-A4-13	G-FR2-A4-14	G-FR2-A4-15
Subcarrier spacing (kHz)	60	60	120	120	120
Allocated resource blocks	66	132	32	66	132
CP-OFDM Symbols per slot (Note 1)	8	8	8	8	8
Modulation	16QAM	16QAM	16QAM	16QAM	16QAM
Code rate (Note 2)	658/1024	658/1024	658/1024	658/1024	658/1024
Payload size (bits)	16392	32776	7936	16392	32776
Transport block CRC (bits)	24	24	24	24	24
Code block CRC size (bits)	24	24	-	24	24
Number of code blocks - C	2	4	1	2	4
Code block size including CRC (bits) (Note 2)	8232	8224	7960	8232	8224
Total number of bits per slot without PT-RS	25344	50688	12288	25344	50688
Total number of bits per slot with PT-RS (Note 4)	24288	48576	11776	24288	48576
Total symbols per slot without PT-RS	6336	12672	3072	6336	12672
Total symbols per slot with PT-RS (Note 4)	6072	12144	2944	6072	12144
NOTE 1: DM-RS configuration type = 1 with DM-RS duration = single-symbol DM-RS and the number of DM-RS CDM groups without data is 2, additional DM-RS position = pos1 with $l_0 = 0$ and $l = 8$ as per table 6.4.1.1.3-3 of TS 38.211 [20].					
NOTE 2: Code block size including CRC (bits) equals to $K'$ in clause 5.2.2 of TS 38.212 [19].					
NOTE 3: The calculation of the "Total number of bits per slot" and "Total symbols per slot" fields include the REs taken up by CSI part 1 and CSI part 2, if present.					
NOTE 4: PT-RS configuration $K_{PT-RS} = 2$ , $L_{PT-RS} = 1$ .					

**Table A.4-7A: FRC parameters for FR2-2 PUSCH performance requirements, transform precoding disabled, Additional DM-RS position = pos1 and 1 transmission layer (16QAM, R=658/1024)**

Reference channel	G-FR2-A4-21	G-FR2-A4-22	G-FR2-A4-23
Subcarrier spacing [kHz]	120	120	480
Allocated resource blocks	66	264	66
CP-OFDM Symbols per slot (Note 1)	8	8	8
Modulation	16QAM	16QAM	16QAM
Code rate (Note 2)	658/1024	658/1024	658/1024
Payload size (bits)	16392	65576	16392
Transport block CRC (bits)	24	24	24
Code block CRC size (bits)	24	24	24
Number of code blocks - C	2	8	2
Code block size including CRC (bits) (Note 2)	8232	8224	8232
Total number of bits per slot without PT-RS	25344	101376	25344
Total number of bits per slot with PT-RS (Note 4)	24288	97152	24288
Total symbols per slot without PT-RS	6336	25344	6336
Total symbols per slot with PT-RS (Note 4)	6072	24288	6072
NOTE 1: DM-RS configuration type = 1 with DM-RS duration = single-symbol DM-RS and the number of DM-RS CDM groups without data is 2, Additional DM-RS position = pos1 with $l_0 = 0$ and $l = 8$ as per Table 6.4.1.1.3-3 of TS 38.211 [9].			
NOTE 2: Code block size including CRC (bits) equals to $K'$ in sub-clause 5.2.2 of TS 38.212 [15].			
NOTE 3: The calculation of the "Total number of bits per slot" and "Total symbols per slot" fields include the REs taken up by CSI part 1 and CSI part 2, if present.			
NOTE 4: PT-RS configuration $K_{PT-RS} = 2$ , $L_{PT-RS} = 1$ .			

**Table A.4-8: FRC parameters for FR2-1 PUSCH performance requirements, transform precoding disabled, additional DM-RS position = pos1 and 2 transmission layers (16QAM, R=658/1024)**

Reference channel	G-FR2-A4-16	G-FR2-A4-17	G-FR2-A4-18	G-FR2-A4-19	G-FR2-A4-20
Subcarrier spacing (kHz)	60	60	120	120	120
Allocated resource blocks	66	132	32	66	132
CP-OFDM Symbols per slot (Note 1)	8	8	8	8	8
Modulation	16QAM	16QAM	16QAM	16QAM	16QAM
Code rate (Note 2)	658/1024	658/1024	658/1024	658/1024	658/1024
Payload size (bits)	32776	65576	15880	32776	65576
Transport block CRC (bits)	24	24	24	24	24
Code block CRC size (bits)	24	24	24	24	24
Number of code blocks - C	4	8	2	4	8
Code block size including CRC (bits) (Note 2)	8224	8224	7976	8224	8224
Total number of bits per slot without PT-RS	50688	101376	24576	50688	101376
Total number of bits per slot with PT-RS (Note 3)	48576	97152	23552	48576	97152
Total symbols per slot without PT-RS	12672	25344	6144	12672	25344
Total symbols per slot with PT-RS (Note 3)	12144	24288	5888	12144	24288
NOTE 1: DM-RS configuration type = 1 with DM-RS duration = single-symbol DM-RS and the number of DM-RS CDM groups without data is 2, additional DM-RS position = pos1 with $l_0 = 0$ and $l = 8$ as per table 6.4.1.1.3-3 of TS 38.211 [20].					
NOTE 2: Code block size including CRC (bits) equals to $K'$ in clause 5.2.2 of TS 38.212 [19].					
NOTE 3: PT-RS configuration $K_{PT-RS} = 2$ , $L_{PT-RS} = 1$ .					

**Table A.4-8A: Void**

## A.5 Fixed Reference Channels for performance requirements (64QAM, R=567/1024)

The parameters for the reference measurement channels are specified in table A.5-2 for FR1 PUSCH performance requirements with transform precoding disabled, additional DM-RS position = pos1 and 1 transmission layer.

The parameters for the reference measurement channels are specified in table A.5-3 to table A.5-4 for FR2-1 PUSCH performance requirements:

- FRC parameters are specified in table A.5-3 for FR2-1 PUSCH with transform precoding disabled, additional DM-RS position = pos0 and 1 transmission layer.
- FRC parameters are specified in table A.5-4 for FR2-1 PUSCH with transform precoding disabled, additional DM-RS position = pos1 and 1 transmission layer.

The parameters for the reference measurement channels are specified in table A.5-4A and table A.5-7 for FR2-2 PUSCH performance requirements:

- FRC parameters are specified in table A.5-4A for FR2-2 PUSCH with transform precoding disabled, additional DM-RS position = pos1 and 1 transmission layer.
- FRC parameters are specified in table A.5-7 for FR2-2 PUSCH with transform precoding disabled, *Additional DM-RS position = pos1* and 2 transmission layers.



Table A.5-1: Void

Table A.5-2: FRC parameters for FR1 PUSCH performance requirements, transform precoding disabled, additional DM-RS position = pos1 and 1 transmission layer (64QAM, R=567/1024)

Reference channel	G-FR1-A5-8	G-FR1-A5-9	G-FR1-A5-10	G-FR1-A5-11	G-FR1-A5-12	G-FR1-A5-13	G-FR1-A5-14
Subcarrier spacing (kHz)	15	15	15	30	30	30	30
Allocated resource blocks	25	52	106	24	51	106	273
CP-OFDM Symbols per slot (Note 1)	12	12	12	12	12	12	12
Modulation	64QAM	64QAM	64QAM	64QAM	64QAM	64QAM	64QAM
Code rate (Note 2)	567/1024	567/1024	567/1024	567/1024	567/1024	567/1024	567/1024
Payload size (bits)	12040	25104	50184	11528	24576	50184	131176
Transport block CRC (bits)	24	24	24	24	24	24	24
Code block CRC size (bits)	24	24	24	24	24	24	24
Number of code blocks - C	2	3	6	2	3	6	16
Code block size including CRC (bits) (Note 2)	6056	8400	8392	5800	8224	8392	8224
Total number of bits per slot	21600	44928	91584	20736	44064	91584	235872
Total symbols per slot	3600	7488	15264	3456	7344	15264	39312
NOTE 1: DM-RS configuration type = 1 with DM-RS duration = single-symbol DM-RS and the number of DM-RS CDM groups without data is 2, additional DM-RS position = pos1, $l_0 = 2$ and $l = 11$ for PUSCH mapping type A, $l_0 = 0$ and $l = 10$ for PUSCH mapping type B as per table 6.4.1.1.3-3 of TS 38.211 [20].							
NOTE 2: Code block size including CRC (bits) equals to $K'$ in clause 5.2.2 of TS 38.212 [19].							

Table A.5-3: FRC parameters for FR2-1 PUSCH performance requirements, transform precoding disabled, additional DM-RS position = pos0 and 1 transmission layer (64QAM, R=567/1024)

Reference channel	G-FR2-A5-1	G-FR2-A5-2	G-FR2-A5-3	G-FR2-A5-4	G-FR2-A5-5
Subcarrier spacing (kHz)	60	60	120	120	120
Allocated resource blocks	66	132	32	66	132
CP-OFDM Symbols per slot (Note 1)	9	9	9	9	9
Modulation	64QAM	64QAM	64QAM	64QAM	64QAM
Code rate (Note 2)	567/1024	567/1024	567/1024	567/1024	567/1024
Payload size (bits)	23568	47112	11528	23568	47112
Transport block CRC (bits)	24	24	24	24	24
Code block CRC size (bits)	24	24	24	24	24
Number of code blocks - C	3	6	2	3	6
Code block size including CRC (bits) (Note 2)	7888	7880	5800	7888	7880
Total number of bits per slot without PT-RS	42768	85536	20736	42768	85536
Total number of bits per slot with PT-RS (Note 3)	40986	81972	19872	40986	81972
Total symbols per slot without PT-RS	7128	14256	3456	7128	14256
Total symbols per slot with PT-RS (Note 3)	6831	13662	3312	6831	13662
NOTE 1: DM-RS configuration type = 1 with DM-RS duration = single-symbol DM-RS and the number of DM-RS CDM groups without data is 2, additional DM-RS position = pos0 with $l_0 = 0$ as per table 6.4.1.1.3-3 of TS 38.211 [20].					
NOTE 2: Code block size including CRC (bits) equals to $K'$ in clause 5.2.2 of TS 38.212 [19].					
NOTE 3: PT-RS configuration $K_{PT-RS} = 2$ , $L_{PT-RS} = 1$ .					

**Table A.5-4: FRC parameters for FR2-1 PUSCH performance requirements, transform precoding disabled, additional DM-RS position = pos1 and 1 transmission layer (64QAM, R=567/1024)**

Reference channel	G-FR2-A5-6	G-FR2-A5-7	G-FR2-A5-8	G-FR2-A5-9	G-FR2-A5-10
Subcarrier spacing (kHz)	60	60	120	120	120
Allocated resource blocks	66	132	32	66	132
CP-OFDM Symbols per slot (Note 1)	8	8	8	8	8
Modulation	64QAM	64QAM	64QAM	64QAM	64QAM
Code rate (Note 2)	567/1024	567/1024	567/1024	567/1024	567/1024
Payload size (bits)	21000	42016	10248	21000	42016
Transport block CRC (bits)	24	24	24	24	24
Code block CRC size (bits)	24	24	24	24	24
Number of code blocks - C	3	5	2	3	5
Code block size including CRC (bits) (Note 2)	7032	8432	5160	7032	8432
Total number of bits per slot without PT-RS	38016	76032	18432	38016	76032
Total number of bits per slot with PT-RS (Note 3)	36432	72864	17664	36432	72864
Total symbols per slot without PT-RS	6336	12672	3072	6336	12672
Total symbols per slot with PT-RS (Note 3)	6072	12144	2944	6072	12144
NOTE 1: DM-RS configuration type = 1 with DM-RS duration = single-symbol DM-RS and the number of DM-RS CDM groups without data is 2, additional DM-RS position = pos1 with $l_0 = 0$ and $l = 8$ as per table 6.4.1.1.3-3 of TS 38.211 [20].					
NOTE 2: Code block size including CRC (bits) equals to $K'$ in clause 5.2.2 of TS 38.212 [19].					
NOTE 3: PT-RS configuration $K_{PT-RS} = 2$ , $L_{PT-RS} = 1$ .					

**Table A.5-4A: FRC parameters for FR2-2 PUSCH performance requirements, transform precoding disabled, Additional DM-RS position = pos1 and 1 transmission layer (64QAM, R=567/1024)**

Reference channel	G-FR2-A5-11	G-FR2-A5-12	G-FR2-A5-13
Subcarrier spacing [kHz]	120	120	480
Allocated resource blocks	66	264	66
CP-OFDM Symbols per slot (Note 1)	8	8	8
Modulation	64QAM	64QAM	64QAM
Code rate (Note 2)	567/1024	567/1024	567/1024
Payload size (bits)	21000	83976	21000
Transport block CRC (bits)	24	24	24
Code block CRC size (bits)	24	24	24
Number of code blocks - C	3	10	3
Code block size including CRC (bits) (Note 2)	7032	8424	7032
Total number of bits per slot without PT-RS	38016	152064	38016
Total number of bits per slot with PT-RS (Note 3)	36432	145728	36432
Total symbols per slot without PT-RS	6336	25344	6336
Total symbols per slot with PT-RS (Note 3)	6072	24288	6072
NOTE 1: DM-RS configuration type = 1 with DM-RS duration = single-symbol DM-RS and the number of DM-RS CDM groups without data is 2, Additional DM-RS position = pos1 with $l_0 = 0$ and $l = 8$ as per Table 6.4.1.1.3-3 of TS 38.211 [9].			
NOTE 2: Code block size including CRC (bits) equals to $K'$ in sub-clause 5.2.2 of TS 38.212 [15].			
NOTE 3: PT-RS configuration $K_{PT-RS} = 2$ , $L_{PT-RS} = 1$ .			

**Table A.5-5: FRC parameters for FR1 interlaced PUSCH performance requirements, transform precoding disabled, *additional DM-RS position = pos1* and 1 transmission layer (64QAM, R=567/1024)**

Reference channel	G-FR1-A5-15	G-FR1-A5-16
Subcarrier spacing [kHz]	15	30
Allocated resource blocks	11	11
CP-OFDM Symbols per slot (Note 1)	12	12
Modulation	64QAM	64QAM
Code rate	567/1024	567/1024
Payload size (bits)	5248	5248
Transport block CRC (bits)	24	24
Code block CRC size (bits)	24	24
Number of code blocks - C	1	1
Code block size including CRC (bits) (Note 2)	5272	5272
Total number of bits per slot (Note 3)	9504	9504
Total symbols per slot (Note 3)	1584	1584
<p>NOTE 1: <i>DM-RS configuration type = 1</i> with <i>DM-RS duration = single-symbol DM-RS</i> and the number of DM-RS CDM groups without data is 2, <i>Additional DM-RS position = pos1</i>, <math>l_0 = 2</math> and <math>l = 11</math> for PUSCH mapping type A, <math>l_0 = 0</math> and <math>l = 10</math> for PUSCH mapping type B as per table 6.4.1.1.3-3 of TS 38.211 [20].</p> <p>NOTE 2: Code block size including CRC (bits) equals to <math>K'</math> in clause 5.2.2 of TS 38.212 [19].</p> <p>NOTE 3: The calculation of the "Total number of bits per slot" and "Total symbols per slot" fields include the REs taken up by CG-UCI, if present.</p>		

## A.6 PRACH Test preambles

**Table A.6-1 Test preambles for Normal Mode in FR1**

Burst format	SCS (kHz)	Ncs	Logical sequence index	v
0	1.25	13	22	32
1	1.25	0	22	0
A1, A2, A3, B4, C0, C2	15	23	0	0
	30	46	0	0

**Table A.6-2 Test preambles for Normal Mode in FR2**

Burst format	SCS (kHz)	Ncs	Logical sequence index	v
A1, A2, A3, , B4, C0, C2	60	69	0	0
	120	69	0	0

**Table A.6-3: Test preambles for high speed train restricted set type A**

Burst format	SCS (kHz)	Ncs	Logical sequence index	v
0	1.25	15	384	0

**Table A.6-4: Test preambles for high speed train restricted set type B**

Burst format	SCS (kHz)	Ncs	Logical sequence index	v
0	1.25	15	30	30

**Table A.6-5: Test preambles for high speed train short formats in FR1**

Burst format	SCS (kHz)	Ncs	Logical sequence index	v
A2, B4, C2	15	23	0	0
	30	46	0	0

**Table A.6-6: Test preambles for PRACH with  $L_{RA}=1151$  and  $L_{RA}=571$** 

Burst format	SCS (kHz)	Ncs	Logical sequence index	v
A2, B4, C2	15	164	0	0
	30	190	0	0

**Table A.6-7: Test preambles for high speed train short formats in FR2**

Burst format	SCS (kHz)	Ncs	Logical sequence index	v
C2	120	0	0	0

**Table A.6-8 Test preambles for PRACH with  $L_{RA}=139$ ,  $L_{RA}=571$  and  $L_{RA}=1151$  for 120 KHz and 480 KHz SCS**

Burst format	SCS (kHz)	$L_{RA}$	Ncs	Logical sequence index	v
A2, B4, C2	120	571	285	0	0
	120	1151	575	0	0
	480	139	69	0	0
	480	571	285	0	0

**Table A.6-9: Test preambles for normal mode PRACH with repetitions,  $L_{RA}=139$** 

Burst format	SCS (kHz)	Ncs	Logical sequence index	v
A2, B4, C2	120	69	0	0

## A.7 Fixed Reference Channels for performance requirements (16QAM, $R=434/1024$ )

Note: Different FRC numbers are assigned in TS 38.141-1 [3] for the FRCs in this annex.

The parameters for the reference measurement channels are specified in table A.7-1 for FR2-1 PUSCH performance requirements with transform precoding disabled, additional DM-RS position = pos0 and 2 transmission layers.

The parameters for the reference measurement channels are specified in table A.7-2 for FR2-1 PUSCH performance requirements with transform precoding disabled, additional DM-RS position = pos1 and 2 transmission layers.

The parameters for the reference measurement channels are specified in table A.7-3 for FR2-2 PUSCH performance requirements with transform precoding disabled, additional DM-RS position = pos1 and 2 transmission layers.

Note: The FRC table A.7-4 defined in TS38.104 [2] is not used in this specification.

**Table A.7-1: FRC parameters for FR2-1 PUSCH performance requirements, transform precoding disabled, Additional DM-RS position = pos0 and 2 transmission layers (16QAM, R=434/1024)**

Reference channel	G-FR2-A7-1	G-FR2-A7-2	G-FR2-A7-3	G-FR2-A7-4	G-FR2-A7-5
Subcarrier spacing [kHz]	60	60	120	120	120
Allocated resource blocks	66	132	32	66	132
CP-OFDM Symbols per slot (Note 1)	9	9	9	9	9
Modulation	16QAM	16QAM	16QAM	16QAM	16QAM
Code rate (Note 2)	434/1024	434/1024	434/1024	434/1024	434/1024
Payload size (bits)	24072	48168	11784	24072	48168
Transport block CRC (bits)	24	24	24	24	24
Code block CRC size (bits)	24	24	24	24	24
Number of code blocks - C	3	6	2	3	6
Code block size including CRC (bits) (Note 2)	8056	8056	5928	8056	8056
Total number of bits per slot without PT-RS	57024	114048	27648	57024	114048
Total number of bits per slot with PT-RS (Note 3)	54648	109296	26496	54648	109296
Total symbols per slot without PT-RS	14256	28512	6912	14256	28512
Total symbols per slot with PT-RS (Note 3)	13662	27324	6624	13662	27324
NOTE 1: <i>DM-RS configuration type</i> = 1 with <i>DM-RS duration</i> = single-symbol <i>DM-RS</i> and the number of <i>DM-RS</i> CDM groups without data is 2, <i>Additional DM-RS position</i> = pos0 with $l_0 = 0$ as per Table 6.4.1.1.3-3 of TS 38.211 [20].					
NOTE 2: Code block size including CRC (bits) equals to $K'$ in clause 5.2.2 of TS 38.212 [19].					
NOTE 3: PT-RS configuration $K_{PT-RS} = 2$ , $L_{PT-RS} = 1$ .					

**Table A.7-2: FRC parameters for FR2-1 PUSCH performance requirements, transform precoding disabled, Additional DM-RS position = pos1 and 2 transmission layers (16QAM, R=434/1024)**

Reference channel	G-FR2-A7-6	G-FR2-A7-7	G-FR2-A7-8	G-FR2-A7-9	G-FR2-A7-10
Subcarrier spacing [kHz]	60	60	120	120	120
Allocated resource blocks	66	132	32	66	132
CP-OFDM Symbols per slot (Note 1)	8	8	8	8	8
Modulation	16QAM	16QAM	16QAM	16QAM	16QAM
Code rate (Note 2)	434/1024	434/1024	434/1024	434/1024	434/1024
Payload size (bits)	21504	43032	10504	21504	43032
Transport block CRC (bits)	24	24	24	24	24
Code block CRC size (bits)	24	24	24	24	24
Number of code blocks - C	3	6	2	3	6
Code block size including CRC (bits) (Note 2)	7200	7200	5288	7200	7200
Total number of bits per slot without PT-RS	50688	101376	24576	50688	101376
Total number of bits per slot with PT-RS (Note 3)	48576	97152	23552	48576	97152
Total symbols per slot without PT-RS	12672	25344	6144	12672	25344
Total symbols per slot with PT-RS (Note 3)	12144	24288	5888	12144	24288
NOTE 1: <i>DM-RS configuration type</i> = 1 with <i>DM-RS duration</i> = single-symbol <i>DM-RS</i> and the number of <i>DM-RS</i> CDM groups without data is 2, <i>Additional DM-RS position</i> = pos1 with $l_0 = 0$ and $l = 8$ as per Table 6.4.1.1.3-3 of TS 38.211 [20].					
NOTE 2: Code block size including CRC (bits) equals to $K'$ in clause 5.2.2 of TS 38.212 [19].					
NOTE 3: PT-RS configuration $K_{PT-RS} = 2$ , $L_{PT-RS} = 1$ .					

**Table A.7-3: FRC parameters for FR2-2 PUSCH performance requirements, transform precoding disabled, *Additional DM-RS position = pos1* and 2 transmission layers (16QAM, R=434/1024)**

Reference channel	G-FR2-A7-11	G-FR2-A7-12	G-FR2-A7-13
Subcarrier spacing [kHz]	120	120	480
Allocated resource blocks	66	264	66
CP-OFDM Symbols per slot (Note 1)	8	8	8
Modulation	16QAM	16QAM	16QAM
Code rate (Note 2)	434/1024	434/1024	434/1024
Payload size (bits)	21504	86040	21504
Transport block CRC (bits)	24	24	24
Code block CRC size (bits)	24	24	24
Number of code blocks - C	3	11	3
Code block size including CRC (bits) (Note 2)	7200	7848	7200
Total number of bits per slot without PT-RS	50688	202752	50688
Total number of bits per slot with PT-RS (Note 4)	48576	194304	48576
Total symbols per slot without PT-RS	12672	50688	12672
Total symbols per slot with PT-RS (Note 4)	12144	48576	12144
NOTE 1: <i>DM-RS configuration type = 1</i> with <i>DM-RS duration = single-symbol DM-RS</i> and the number of DM-RS CDM groups without data is 2, <i>Additional DM-RS position = pos1</i> with $l_0 = 0$ and $l = 8$ as per Table 6.4.1.1.3-3 of TS 38.211 [9].			
NOTE 2: Code block size including CRC (bits) equals to $K'$ in sub-clause 5.2.2 of TS 38.212 [15].			
NOTE 3: The calculation of the "Total number of bits per slot" and "Total symbols per slot" fields include the REs taken up by CSI part 1 and CSI part 2, if present.			
NOTE 4: PT-RS configuration $K_{PT-RS} = 2$ , $L_{PT-RS} = 1$ .			

## A.8 Fixed Reference Channels for performance requirements (QPSK, R=157/1024)

Note: Different FRC numbers are assigned in TS 38.141-1 [3] for the FRCs in this annex.

The parameters for the reference measurement channels are specified in table A.8-1 and A.8-2 for FR1 PUSCH performance requirements for 2-step RA type with *Additional DM-RS position* equals to *pos2* and *pos1* respectively.

**Table A.8-1: FRC parameters for FR1 PUSCH performance requirements, transform precoding disabled, additional DM-RS position = pos2 and 1 transmission layer (QPSK, R=193/1024)**

Reference channel	G-FR1-A8-1	G-FR1-A8-2
Subcarrier spacing [kHz]	15	30
Allocated resource blocks	2	2
CP-OFDM Symbols per slot (Note 1)	11	11
Modulation	QPSK	QPSK
Code rate (Note 2)	157/1024	157/1024
Payload size (bits)	80	80
Transport block CRC (bits)	16	16
Code block CRC size (bits)	0	0
Number of code blocks - C	1	1
Code block size including CRC (bits) (Note 2)	96	96
Total number of bits per slot	528	528
Total symbols per slot	264	264
NOTE 1: <i>DM-RS configuration type = 1</i> with <i>DM-RS duration = single-symbol DM-RS</i> and the number of DM-RS CDM groups without data is 2, <i>Additional DM-RS position = pos2</i> with $l_0 = 2$ as per Table 6.4.1.1.3-3 of TS 38.211 [20].		
NOTE 2: Code block size including CRC (bits) equals to $K'$ in clause 5.2.2 of TS 38.212 [19].		

**Table A.8-2: FRC parameters for FR1 PUSCH performance requirements, transform precoding disabled, additional DM-RS position = pos1 and 1 transmission layer (QPSK, R=193/1024)**

Reference channel	G-FR1-A8-3	G-FR1-A8-4
Subcarrier spacing [kHz]	15	30
Allocated resource blocks	2	2
CP-OFDM Symbols per slot (Note 1)	12	12
Modulation	QPSK	QPSK
Code rate (Note 2)	157/1024	157/1024
Payload size (bits)	88	88
Transport block CRC (bits)	16	16
Code block CRC size (bits)	0	0
Number of code blocks - C	1	1
Code block size including CRC (bits) (Note 2)	104	104
Total number of bits per slot	576	576
Total symbols per slot	288	288
NOTE 1: <i>DM-RS configuration type = 1 with DM-RS duration = single-symbol DM-RS and the number of DM-RS CDM groups without data is 2, Additional DM-RS position = pos1 with <math>l_0=2</math> as per Table 6.4.1.1.3-3 of TS 38.211 [20].</i>		
NOTE 2: Code block size including CRC (bits) equals to $K'$ in clause 5.2.2 of TS 38.212 [19].		

## A.9 Fixed Reference Channels for performance requirements (256QAM, R=682.5/1024)

Note: Different FRC numbers are assigned in TS 38.141-1 [3] for the FRCs in this annex.

The parameters for the reference measurement channels are specified in table A.9-1 for FR1 PUSCH performance requirements:

- FRC parameters are specified in table A.9-1 for FR1 PUSCH with transform precoding disabled, *Additional DM-RS position = pos1* and 1 transmission layer.

The parameters for the reference measurement channels are specified in table A.9-2 and A.9-3 for FR2-1 PUSCH performance requirements:

- FRC parameters are specified in table A.9-2 for FR2-1 PUSCH with transform precoding disabled, *Additional DM-RS position = pos0* and 1 transmission layer.
- FRC parameters are specified in table A.9-3 for FR2-1 PUSCH with transform precoding disabled, *Additional DM-RS position = pos1* and 1 transmission layer.

**Table A.9-1: FRC parameters for FR1 PUSCH performance requirements, transform precoding disabled, Additional DM-RS position = pos1 and 1 transmission layer (256QAM, R=682.5/1024)**

Reference channel	G-FR1-A9-1	G-FR1-A9-2	G-FR1-A9-3	G-FR1-A9-4	G-FR1-A9-5
Subcarrier spacing [kHz]	15	15	30	30	30
Allocated resource blocks	25	52	24	106	273
CP-OFDM Symbols per slot (Note 1)	12	12	12	12	12
Modulation	256QAM	256QAM	256QAM	256QAM	256QAM
Code rate (Note 2)	682.5/1024	682.5/1024	682.5/1024	682.5/1024	682.5/1024
Payload size (bits)	18960	39936	18432	81976	208976
Transport block CRC (bits)	24	24	24	24	24
Code block CRC size (bits)	24	24	24	24	24
Number of code blocks - C	3	5	3	10	25
Code block size including CRC (bits) (Note 2)	6352	8016	6176	8224	8384
Total number of bits per slot	28800	59904	27648	122112	314496
Total symbols per slot	3600	7488	3456	15264	39312
NOTE 1: DM-RS configuration type = 1 with DM-RS duration = single-symbol DM-RS and the number of DM-RS CDM groups without data is 2, Additional DM-RS position = pos1, $l_0 = 2$ and $l = 11$ for PUSCH mapping type A, $l_0 = 0$ and $l = 10$ for PUSCH mapping type B as per table 6.4.1.1.3-3 of TS 38.211 [5].					
NOTE 2: Code block size including CRC (bits) equals to $K'$ in clause 5.2.2 of TS 38.212 [15].					

**Table A.9-2: FRC parameters for FR2-1 PUSCH performance requirements, transform precoding disabled, Additional DM-RS position = pos0 and 1 transmission layer (256QAM, R=682.5/1024)**

Reference channel	G-FR2-A9-1	G-FR2-A9-2	G-FR2-A9-3
Subcarrier spacing [kHz]	120	120	60
Allocated resource blocks	32	132	66
CP-OFDM Symbols per slot (Note 1)	9	9	9
Modulation	256QAM	256QAM	256QAM
Code rate (Note 2)	682.5/1024	682.5/1024	682.5/1024
Payload size (bits)	18432	75792	37896
Transport block CRC (bits)	24	24	24
Code block CRC size (bits)	24	24	24
Number of code blocks - C	3	9	5
Code block size including CRC (bits) (Note 2)	6176	8448	7608
Total number of bits per slot without PT-RS	27648	114048	57024
Total number of bits per slot with PT-RS (Note 3)	26496	109296	54648
Total resource elements per slot without PT-RS	3456	14256	7128
Total resource elements per slot with PT-RS (Note 3)	3312	13662	6831



**Table A.9-3: FRC parameters for FR2-1 PUSCH performance requirements, transform precoding disabled, Additional DM-RS position = pos1 and 1 transmission layer (256QAM, R=682.5/1024)**

Reference channel	G-FR2-A9-4	G-FR2-A9-5	G-FR2-A9-6
Subcarrier spacing [kHz]	120	120	60
Allocated resource blocks	32	132	66
Modulation	256QAM	256QAM	256QAM
Code rate (Note 2)	682.5/1024	682.5/1024	682.5/1024
Payload size (bits)	16392	67584	33816
Transport block CRC (bits)	24	24	24
Code block CRC size (bits)	24	24	24
Number of code blocks - C	2	9	5
Code block size including CRC (bits) (Note 2)	8232	7536	6792
Total number of bits per slot without PT-RS	24576	101376	50688
Total number of bits per slot with PT-RS (Note 3)	23552	97152	48576
Total resource elements per slot without PT-RS	3072	12672	6336
Total resource elements per slot with PT-RS (Note 3)	2944	12144	6072

## A.10 Fixed Reference Channels for performance requirements (64QAM, R=517/1024)

The parameters for the reference measurement channels are specified in table A.10-1, A.10-2 and A.10-3 for FR2 PUSCH performance requirements:

- FRC parameters are specified in table A.10-1 for FR2 PUSCH with transform precoding disabled, *Additional DM-RS position = pos0* and 1 transmission layer.
- FRC parameters are specified in table A.10-2 for FR2 PUSCH with transform precoding disabled, *Additional DM-RS position = pos1* and 1 transmission layer.
- FRC parameters are specified in table A.10-3 for FR2 PUSCH with transform precoding disabled, *Additional DM-RS position = pos2* and 1 transmission layer.

The parameters for the reference measurement channels are specified in table A.10-4, table A.10-5 and table A.10-6 for FR2 PUSCH UL timing adjustment performance requirements:

- FRC parameters are specified in table A.10-4 for FR2 UL timing adjustment requirements, PUSCH with transform precoding disabled, *Additional DM-RS position = pos0* and 1 transmission layer.
- FRC parameters are specified in table A.10-5 for FR2 UL timing adjustment requirements, PUSCH with transform precoding disabled, *Additional DM-RS position = pos1* and 1 transmission layer.
- FRC parameters are specified in table A.10-6 for FR2 UL timing adjustment requirements, PUSCH with transform precoding disabled, *Additional DM-RS position = pos2* and 1 transmission layer.

**Table A.10-1: FRC parameters for FR2 PUSCH performance requirements, transform precoding disabled, Additional DM-RS position = pos0 and 1 transmission layer (64QAM, R=517/1024)**

Reference channel	G-FR2-A10-1	G-FR2-A10-2
Subcarrier spacing [kHz]	120	120
Allocated resource blocks	32	132
Data bearing CP-OFDM Symbols per slot (Note 1)	9	9
Modulation	64QAM	64QAM
Code rate (Note 2)	517/1024	517/1024
Payload size (bits)	10504	43032
Transport block CRC (bits)	24	24
Code block CRC size (bits)	24	24
Number of code blocks - C	2	6
Code block size including CRC (bits) (Note 2)	5288	7200
Total number of bits per slot without PT-RS	20736	85536
Total number of bits per slot with PT-RS (Note 3)	19872	81972
Total resource elements per slot without PT-RS	3456	14256
Total resource elements per slot with PT-RS (Note 3)	3312	13662
NOTE 1: DM-RS configuration type = 1 with DM-RS duration = single-symbol DM-RS and the number of DM-RS CDM groups without data is 2, Additional DM-RS position = pos0 with $l_0 = 0$ as per Table 6.4.1.1.3-3 of TS 38.211 [9].		
NOTE 2: Code block size including CRC (bits) equals to $K'$ in sub-clause 5.2.2 of TS 38.212 [15].		
NOTE 3: PT-RS configuration $K_{PT-RS} = 2$ , $L_{PT-RS} = 1$ .		

**Table A.10-2: FRC parameters for FR2 PUSCH performance requirements, transform precoding disabled, Additional DM-RS position = pos1 and 1 transmission layer (64QAM, R=517/1024)**

Reference channel	G-FR2-A10-3	G-FR2-A10-4
Subcarrier spacing [kHz]	120	120
Allocated resource blocks	32	132
Data bearing CP-OFDM Symbols per slot (Note 1)	8	8
Modulation	64QAM	64QAM
Code rate (Note 2)	517/1024	517/1024
Payload size (bits)	9224	37896
Transport block CRC (bits)	24	24
Code block CRC size (bits)	24	24
Number of code blocks - C	2	5
Code block size including CRC (bits) (Note 2)	4648	7608
Total number of bits per slot without PT-RS	18432	76032
Total number of bits per slot with PT-RS (Note 3)	17664	72864
Total resource elements per slot without PT-RS	3072	12672
Total resource elements per slot with PT-RS (Note 3)	2944	12144
NOTE 1: DM-RS configuration type = 1 with DM-RS duration = single-symbol DM-RS and the number of DM-RS CDM groups without data is 2, Additional DM-RS position = pos1 with $l_0 = 0$ and $l = 8$ as per Table 6.4.1.1.3-3 of TS 38.211 [9].		
NOTE 2: Code block size including CRC (bits) equals to $K'$ in sub-clause 5.2.2 of TS 38.212 [15].		
NOTE 3: PT-RS configuration $K_{PT-RS} = 2$ , $L_{PT-RS} = 1$ .		

**Table A.10-3: FRC parameters for FR2 PUSCH performance requirements, transform precoding disabled, Additional DM-RS position = pos2 and 1 transmission layer (64QAM, R=517/1024)**

Reference channel	G-FR2-A10-5	G-FR2-A10-6
Subcarrier spacing [kHz]	120	120
Allocated resource blocks	32	132
Data bearing CP-OFDM Symbols per slot (Note 1)	7	7
Modulation	64QAM	64QAM
Code rate (Note 2)	517/1024	517/1024
Payload size (bits)	8064	33816
Transport block CRC (bits)	24	24
Code block CRC size (bits)		24
Number of code blocks - C	1	5
Code block size including CRC (bits) (Note 2)	8088	6792
Total number of bits per slot without PT-RS	16128	66528
Total number of bits per slot with PT-RS (Note 3)	15456	63756
Total resource elements per slot without PT-RS	2688	11088
Total resource elements per slot with PT-RS (Note 3)	2576	10626
NOTE 1: <i>DM-RS configuration type = 1 with DM-RS duration = single-symbol DM-RS and the number of DM-RS CDM groups without data is 2, Additional DM-RS position = pos2 with <math>l_0 = 0</math> and <math>l = 4,8</math> as per Table 6.4.1.1.3-3 of TS 38.211 [9].</i>		
NOTE 2: Code block size including CRC (bits) equals to $K'$ in sub-clause 5.2.2 of TS 38.212 [15].		
NOTE 3: PT-RS configuration $K_{PT-RS} = 2, L_{PT-RS} = 1$ .		

**Table A.10-4: FRC parameters for FR2 UL timing adjustment requirements, PUSCH with transform precoding disabled, Additional DM-RS position = pos0 and 1 transmission layer (64QAM, R=517/1024)**

Reference channel	G-FR2-A10-7	G-FR2-A10-8
Subcarrier spacing [kHz]	120	120
Allocated resource blocks	16	66
Data bearing CP-OFDM Symbols per slot (Note 1)	9	9
Modulation	64QAM	64QAM
Code rate (Note 2)	517/1024	517/1024
Payload size (bits)	5248	21504
Transport block CRC (bits)	24	24
Code block CRC size (bits)	-	24
Number of code blocks - C	1	3
Code block size including CRC (bits) (Note 2)	5272	7200
Total number of bits per slot without PT-RS	10368	42768
Total number of bits per slot with PT-RS (Note 3)	9936	40986
Total resource elements per slot without PT-RS	1728	7128
Total resource elements per slot with PT-RS (Note 3)	1656	6831
NOTE 1: <i>DM-RS configuration type = 1 with DM-RS duration = single-symbol DM-RS and the number of DM-RS CDM groups without data is 2, Additional DM-RS position = pos0 with <math>l_0 = 0</math> as per Table 6.4.1.1.3-3 of TS 38.211 [9].</i>		
NOTE 2: Code block size including CRC (bits) equals to $K'$ in sub-clause 5.2.2 of TS 38.212 [15].		
NOTE 3: PT-RS configuration $K_{PT-RS} = 2, L_{PT-RS} = 1$ .		

**Table A.10-5: FRC parameters for FR2 UL timing adjustment requirements, PUSCH with transform precoding disabled, Additional DM-RS position = pos1 and 1 transmission layer (64QAM, R=517/1024)**

Reference channel	G-FR2-A10-9	G-FR2-A10-10
Subcarrier spacing [kHz]	120	120
Allocated resource blocks	16	66
Data bearing CP-OFDM Symbols per slot (Note 1)	8	8
Modulation	64QAM	64QAM
Code rate (Note 2)	517/1024	517/1024
Payload size (bits)	4608	18960
Transport block CRC (bits)	24	24
Code block CRC size (bits)	-	24
Number of code blocks - C	1	3
Code block size including CRC (bits) (Note 2)	4632	6352
Total number of bits per slot without PT-RS	9216	38016
Total number of bits per slot with PT-RS (Note 3)	8832	36432
Total resource elements per slot without PT-RS	1536	6336
Total resource elements per slot with PT-RS (Note 3)	1472	6072
NOTE 1: <i>DM-RS configuration type = 1 with DM-RS duration = single-symbol DM-RS and the number of DM-RS CDM groups without data is 2, Additional DM-RS position = pos1 with <math>l_0 = 0</math> and <math>l = 8</math> as per Table 6.4.1.1.3-3 of TS 38.211 [9].</i>		
NOTE 2: Code block size including CRC (bits) equals to $K'$ in sub-clause 5.2.2 of TS 38.212 [15].		
NOTE 3: PT-RS configuration $K_{PT-RS} = 2, L_{PT-RS} = 1$ .		

**Table A.10-6: FRC parameters for FR2 UL timing adjustment requirements, PUSCH with transform precoding disabled, Additional DM-RS position = pos2 and 1 transmission layer (64QAM, R=517/1024)**

Reference channel	G-FR2-A10-11	G-FR2-A10-12
Subcarrier spacing [kHz]	120	120
Allocated resource blocks	16	66
Data bearing CP-OFDM Symbols per slot (Note 1)	7	7
Modulation	64QAM	64QAM
Code rate (Note 2)	517/1024	517/1024
Payload size (bits)	4032	16896
Transport block CRC (bits)	24	24
Code block CRC size (bits)	-	24
Number of code blocks - C	1	3
Code block size including CRC (bits) (Note 2)	4056	5664
Total number of bits per slot without PT-RS	8064	33264
Total number of bits per slot with PT-RS (Note 3)	7728	31878
Total resource elements per slot without PT-RS	1344	5544
Total resource elements per slot with PT-RS (Note 3)	1288	5313
NOTE 1: <i>DM-RS configuration type = 1 with DM-RS duration = single-symbol DM-RS and the number of DM-RS CDM groups without data is 2, Additional DM-RS position = pos2 with <math>l_0 = 0</math> and <math>l = 4, 8</math> as per Table 6.4.1.1.3-3 of TS 38.211 [9].</i>		
NOTE 2: Code block size including CRC (bits) equals to $K'$ in sub-clause 5.2.2 of TS 38.212 [15].		
NOTE 3: PT-RS configuration $K_{PT-RS} = 2, L_{PT-RS} = 1$ .		

## A.11 Fixed Reference Channels for performance requirements (64QAM, R=438/1024)

Fixed Reference Channels for performance requirements (64QAM, R=438/1024) are not used in this specification.

## A.12 Void

## A.13 Fixed Reference Channels for performance requirements (64QAM, R=948/1024)

Note: Different FRC numbers are assigned in TS 38.141-1 [3] for the FRCs in this annex.

The parameters for the reference measurement channels are specified in table A.13-1 for FR1 PUSCH performance requirements:

- FRC parameters are specified in table A.13-1 for FR1 PUSCH with transform precoding disabled, *Additional DM-RS position = pos1* and 1 transmission layer.

**Table A.13-1: FRC parameters for FR1 PUSCH performance requirements, transform precoding disabled, additional DM-RS position = pos1 and 1 transmission layer (64QAM, R=948/1024)**

Reference channel	G-FR1-A13-1	G-FR1-A13-2
Subcarrier spacing [kHz]	15	30
Allocated resource blocks	25	24
Data bearing CP-OFDM Symbols per slot (Note 1)	12	12
Modulation	64QAM	64QAM
Code rate (Note 2)	948/1024	948/1024
Payload size (bits)	19968	18960
Transport block CRC (bits)	24	24
Code block CRC size (bits)	24	24
Number of code blocks - C	3	3
Code block size including CRC (bits) (Note 2)	6688	6352
Total number of bits per slot	21600	20736
Total symbols per slot	3600	3456
NOTE 1: DM-RS configuration type = 1 with DM-RS duration = single-symbol DM-RS and the number of DM-RS CDM groups without data is 2, additional DM-RS position = pos1, $l_0 = 2$ and $l = 11$ for PUSCH mapping type A, $l_0 = 0$ and $l = 10$ for PUSCH mapping type B as per table 6.4.1.1.3-3 of TS 38.211 [20].		
NOTE 2: Code block size including CRC (bits) equals to K' in clause 5.2.2 of TS 38.212 [19].		

## A.14 Fixed Reference Channels for performance requirements (256QAM, R=754/1024)

Note: Different FRC numbers are assigned in TS 38.141-1 [3] for the FRCs in this annex.

The parameters for the reference measurement channels are specified in table A.14-1 for FR1 PUSCH performance requirements:

- FRC parameters are specified in table A.14-1 for FR1 PUSCH with transform precoding disabled, *Additional DM-RS position = pos1* and 1 transmission layer.

**Table A.14-1: FRC parameters for FR1 PUSCH performance requirements, transform precoding disabled, additional DM-RS position = pos1 and 1 transmission layer (256QAM, R=754/1024)**

Reference channel	G-FR1-A14-1	G-FR1-A14-2
Subcarrier spacing [kHz]	15	30
Allocated resource blocks	25	24
Data bearing CP-OFDM Symbols per slot (Note 1)	12	12
Modulation	256QAM	256QAM
Code rate (Note 2)	754/1024	754/1024
Payload size (bits)	21000	20496
Transport block CRC (bits)	24	24
Code block CRC size (bits)	24	24
Number of code blocks - C	3	3
Code block size including CRC (bits) (Note 2)	7032	6864
Total number of bits per slot	28800	27648
Total symbols per slot	3600	3456
NOTE 1: DM-RS configuration type = 1 with DM-RS duration = single-symbol DM-RS and the number of DM-RS CDM groups without data is 2, additional DM-RS position = pos1, $l_0 = 2$ and $l = 11$ for PUSCH mapping type A, $l_0 = 0$ and $l = 10$ for PUSCH mapping type B as per table 6.4.1.1.3-3 of TS 38.211 [20].		
NOTE 2: Code block size including CRC (bits) equals to K' in clause 5.2.2 of TS 38.212 [19].		

# Annex B (normative): Environmental requirements for the BS equipment

## B.1 General

For each test in the present document, the environmental conditions under which the BS is to be tested are defined.

For OTA requirements where it is not possible to environmentally control the entire calibrated OTA chamber either localised control of the BS hardware or alternative OTA measurements which are then related to the original specification are acceptable, see annex B.7.

## B.2 Normal test environment

When a normal test environment is specified for a test, the test should be performed within the minimum and maximum limits of the conditions stated in table D.1.

**Table B.1: Limits of conditions for normal test environment**

Condition	Minimum	Maximum
Barometric pressure	86 kPa	106 kPa
Temperature	15 °C	30 °C
Relative humidity	20 %	85 %
Power supply	Nominal, as declared by the manufacturer	
Vibration	Negligible	

The ranges of barometric pressure, temperature and humidity represent the maximum variation expected in the uncontrolled environment of a test laboratory. If it is not possible to maintain these parameters within the specified limits, the actual values shall be recorded in the test report.

NOTE: This may, for instance, be the case for measurements of radiated emissions performed on an open field test site.

## B.3 Extreme test environment

The manufacturer shall declare one of the following:

- 1) The equipment class for the equipment under test, as defined in the IEC 60 721-3-3 [7];
- 2) The equipment class for the equipment under test, as defined in the IEC 60 721-3-4 [8];
- 3) The equipment that does not comply with the mentioned classes, the relevant classes from IEC 60 721 [9] documentation for temperature, humidity and vibration shall be declared.

NOTE: Reduced functionality for conditions that fall outside of the standard operational conditions is not tested in the present document. These may be stated and tested separately.

### B.3.1 Extreme temperature

When an extreme temperature test environment is specified for a test, the test shall be performed at the standard minimum and maximum operating temperatures defined by the manufacturer's declaration for the equipment under test.

Minimum temperature:

The test shall be performed with the environment test equipment and methods including the required environmental phenomena into the equipment, conforming to the test procedure of IEC 60 068-2-1 [10].

Maximum temperature:

The test shall be performed with the environmental test equipment and methods including the required environmental phenomena into the equipment, conforming to the test procedure of IEC 60 068-2-2 [11].

NOTE: It is recommended that the equipment is made fully operational prior to the equipment being taken to its lower operating temperature.

---

## B.4 Vibration

When vibration conditions are specified for a test, the test shall be performed while the equipment is subjected to a vibration sequence as defined by the manufacturer's declaration for the equipment under test. This shall use the environmental test equipment and methods of inducing the required environmental phenomena in to the equipment, conforming to the test procedure of IEC 60 068-2-6 [12]. Other environmental conditions shall be within the ranges specified in annex B.2.

NOTE: The higher levels of vibration may induce undue physical stress in to equipment after a prolonged series of tests. The testing body should only vibrate the equipment during the RF measurement process.

---

## B.5 Power supply

When extreme power supply conditions are specified for a test, the test shall be performed at the standard upper and lower limits of operating voltage defined by manufacturer's declaration for the equipment under test.

Upper voltage limit:

The equipment shall be supplied with a voltage equal to the upper limit declared by the manufacturer (as measured at the input terminals to the equipment). The tests shall be carried out at the steady state minimum and maximum temperature limits declared by the manufacturer for the equipment, to the methods described in IEC 60 068-2-1 [10] Test Ab/Ad and IEC 60 068-2-2 [11] Test Bb/Bd: Dry heat.

Lower voltage limit:

The equipment shall be supplied with a voltage equal to the lower limit declared by the manufacturer (as measured at the input terminals to the equipment). The tests shall be carried out at the steady state minimum and maximum temperature limits declared by the manufacturer for the equipment, to the methods described in IEC 60 068-2-1 [10] Test Ab/Ad and IEC 60 068-2-2 [11] Test Bb/Bd: Dry heat.

---

## B.6 Measurement of test environments

The measurement accuracy of the BS test environments defined in annex B shall be:

Pressure:  $\pm 5$  kPa  
Temperature:  $\pm 2$  degrees  
Relative humidity:  $\pm 5$  %  
DC voltage:  $\pm 1.0$  %  
AC voltage:  $\pm 1.5$  %  
Vibration: 10 %  
Vibration frequency: 0.1 Hz

The above values shall apply unless the test environment is otherwise controlled and the specification for the control of the test environment specifies the uncertainty for the parameter.



## B.7 OTA extreme test methods

### B.7.1 Direct far field method

The BS under test is placed inside a sealed RF transparent environmental enclosure, as showed in Figure B.7.1-1. This is connected to an environment control system which regulates the temperature inside the enclosure. The remaining equipment inside the OTA chamber (any suitable antenna test range chamber type is acceptable) is outside the environmental control and is at nominal temperature. Positioners, test antennas and all other OTA test equipment do not need to be specified over the extreme temperature range.

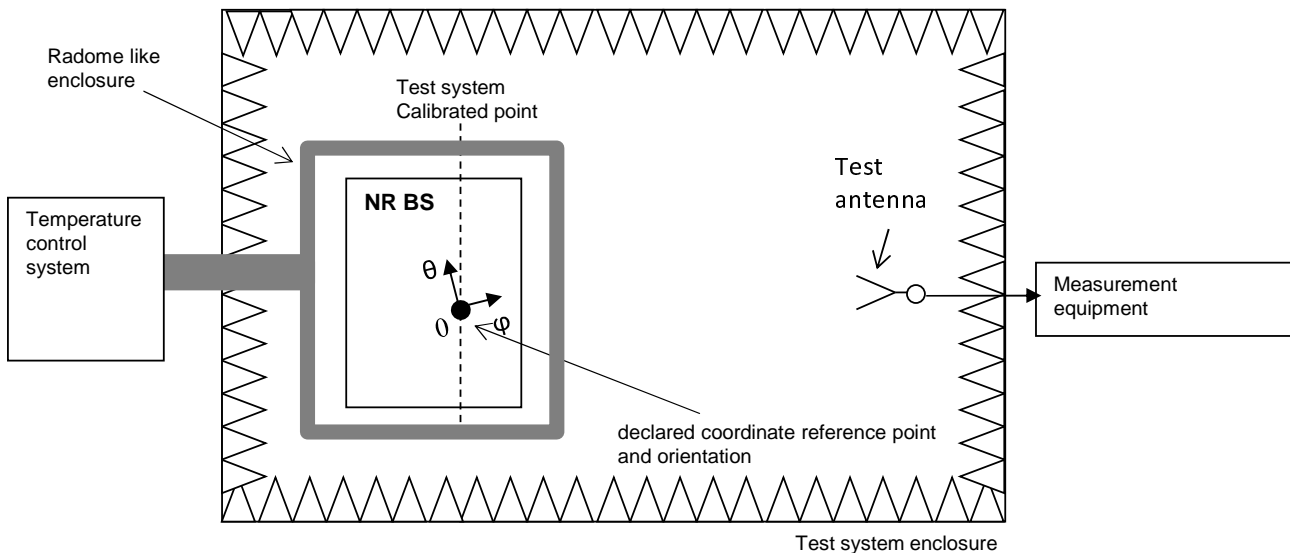

**Figure B.7.1-1: Measurement set up for extreme conditions for EIRP accuracy using direct far field method**

The presence of the environmental chamber inside the OTA chamber may affect the measurement accuracy due to additional reflections and refractions, also the loss through the environmental enclosure may not be consistent with direction as the path through the radome may vary with angle. Hence the system should be calibrated in all tested directions, frequencies and temperatures if necessary.

**NOTE:** Currently only a single direction is specified for extreme testing so a single calibration direction is sufficient.

Conformance may be demonstrated by measuring the difference between the nominal measurement and the extreme measurement ( $\Delta_{\text{sample}}$ ) or by measuring  $P_{\text{max,c,EIRP, extreme}}$  directly.

Measure EIRP for any two orthogonal polarizations (denoted  $p_1$  and  $p_2$ ) and calculate total radiated transmit power for particular *beam direction pair* as  $\text{EIRP} = \text{EIRP}_{p_1} + \text{EIRP}_{p_2}$ .

### B.7.2 Relative method

The BS under test is placed inside a small (compared to a far field chamber) anechoic chamber which is both RF a screened and suitable for environmental conditioning. The RF conditions inside the chamber are absorptive and capable of dissipating the power of the BS when radiating. A sample antenna or RF probe are placed in a location which gives a sample of the main beam EIRP but does not have to accurately measure the EIRP directly, instead the near-field response is measured. For this method test components are exposed to the full temperature range for example the test antenna/probe, cables, absorbers etc. may change as a function of temperature.

Using the relative method it is also necessary to measure the EIRP under nominal conditions using an appropriately calibrated far field (or near filed) test range to obtain  $P_{\text{max,c,EIRP}}$ .

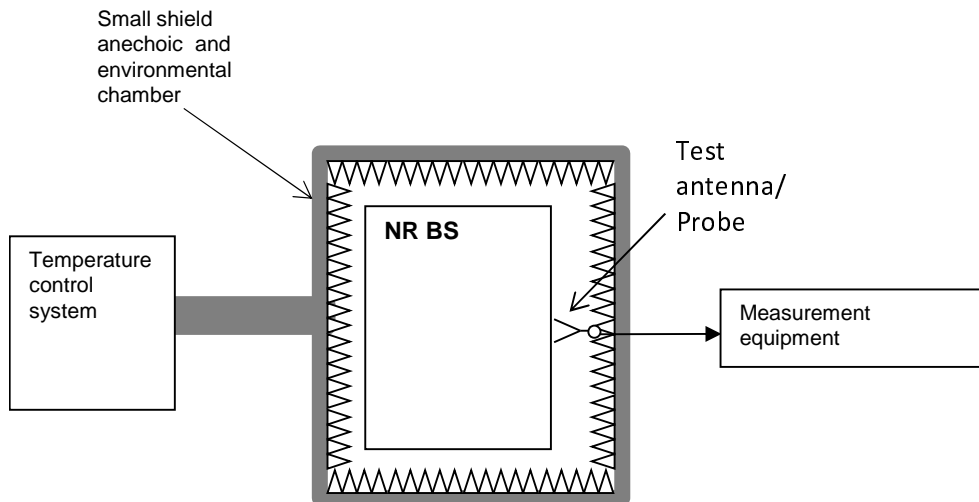

**Figure B.7.2-1: Measurement set up for extreme conditions for EIRP accuracy using difference method**

Measurements from the test antenna/probe are taken under nominal conditions and extreme conditions to calculate ( $\Delta_{\text{sample}}$ ). The difference between the nominal and extreme conditions ( $\Delta_{\text{sample}}$ ) is then used along with the nominal EIRP measurement ( $P_{\text{max,c,EIRP}}$ ) made in the appropriate far field or near field chamber and compared against the extreme requirement. As follows:

$$P_{\text{max,c,EIRP, extreme}} = P_{\text{max,c,EIRP}} + \Delta_{\text{sample}}$$

Measure EIRP for any two orthogonal polarizations (denoted p1 and p2) and calculate total radiated transmit power for particular *beam direction pair* as  $\text{EIRP} = \text{EIRP}_{\text{p1}} + \text{EIRP}_{\text{p2}}$ .

---

## Annex C (informative): Test tolerances and derivation of test requirements

The test requirements explicitly defined in this specification have been calculated by relaxing the minimum requirements of the core specification TS 38.104 [2] using the test tolerances (TT) defined here. When the TT value is zero, the test requirement will be the same as the minimum requirement. When the TT value is non-zero, the test requirements will differ from the minimum requirements, and the formula used for this relaxation is given in the following tables.

The  $TT_{OTA}$  values are derived from OTA Test System uncertainties, regulatory requirements and criticality to system performance. As a result, the  $TT_{OTA}$  values may sometimes be set to zero.

The  $TT_{OTA}$  values should not be modified for any reason e.g. to take account of commonly known OTA Test System errors (such as mismatch, cable loss, etc.).

Note that a formula for applying  $TT_{OTA}$  values is provided for all OTA tests, even those with a test tolerance of zero. This is necessary in the case where the OTA Test System uncertainty is greater than that allowed in clause 4.1.2. In this event, the excess error shall be subtracted from the defined  $TT_{OTA}$  value in order to generate the correct tightened test requirements as defined in this annex.

## C.1 Measurement of transmitter

Table C.1-1: Derivation of test requirements (FR1 OTA transmitter tests)

Test	Minimum requirement in TS 38.104 [2]	Test Tolerance (TT <sub>OTA</sub> )	Test requirement in the present document
6.2 Radiated transmit power	See TS 38.104 [2], clause 9.2	Normal conditions: 1.1 dB, $f \leq 3.0$ GHz 1.3 dB, $3.0 \text{ GHz} < f \leq 4.2 \text{ GHz}$ 1.3 dB, $4.2 \text{ GHz} < f \leq 7.125$ GHz  Extreme conditions: 2.5 dB, $f \leq 3.0$ GHz 2.6 dB, $3.0 \text{ GHz} < f \leq 4.2 \text{ GHz}$ 2.6 dB, $4.2 \text{ GHz} < f \leq 7.125$ GHz	Formula: Upper limit + TT, Lower limit – TT
6.3 OTA base station output power	See TS 38.104 [2], clause 9.3	1.4 dB, $f \leq 3.0$ GHz 1.5 dB, $3.0 \text{ GHz} < f \leq 4.2 \text{ GHz}$ 1.5 dB, $4.2 \text{ GHz} < f \leq 7.125$ GHz	Formula: Upper limit + TT, Lower limit – TT
6.4 OTA output power dynamics	See TS 38.104 [2], clause 9.4	0.4 dB	Formula: Total power dynamic range – TT
6.5.1 OTA transmitter OFF power	See TS 38.104 [2], clause 9.5.2	3.4 dB, $f \leq 3.0$ GHz 3.6 dB, $3.0\text{GHz} < f \leq 4.2\text{GHz}$ 3.6 dB, $4.2\text{GHz} < f \leq 7.125$ GHz	Formula: Minimum Requirement + TT
6.6.2 OTA frequency Error	See TS 38.104 [2], clause 9.6.1	12 Hz	Formula: Frequency Error limit + TT
6.6.3 OTA Modulation quality (EVM)	See TS 38.104 [2], clause 9.6.2	1%	Formula: EVM limit + TT
6.6.4 OTA time alignment error	See TS 38.104 [2], clause 9.6.3	25 ns	
6.7.2 OTA occupied bandwidth	See TS 38.104 [2], clause 9.7.2	0 Hz	Formula: Minimum Requirement + TT
6.7.3 OTA Adjacent Channel Leakage Power Ratio (ACLR)	See TS 38.104 [2], clause 9.7.3	Relative: 1.0 dB, $f \leq 3.0\text{GHz}$ 1.2 dB, $3.0\text{GHz} < f \leq 4.2\text{GHz}$ 1.2 dB, $4.2\text{GHz} < f \leq 7.125$ GHz  Absolute: 0 dB	Formula: Relative limit - TT Absolute limit +TT
6.7.4 OTA operating band unwanted emissions	See TS 38.104 [2], clause 9.7.4	Offsets < 10MHz 1.8 dB, $f \leq 3.0\text{GHz}$ 2 dB, $3.0\text{GHz} < f \leq 4.2\text{GHz}$ 2 dB, $4.2\text{GHz} < f \leq 7.125 \text{ GHz}$  Offsets $\geq 10\text{MHz}$ : 0 dB  Additional limits for bands n50, n51, n74, n75, n76: 0 dB	Formula: Minimum Requirement + TT
6.7.5.2 General transmitter spurious emissions requirements Category A	See TS 38.104 [2], clause 9.7.5.2.2	0 dB	Formula: Minimum Requirement + TT
6.7.5.2 General transmitter spurious emissions requirements Category B	See TS 38.104 [2], clause 9.7.5.2.2	0 dB	Formula: Minimum Requirement + TT
6.7.5.3 Protection of the BS receiver of own or different BS	See TS 38.104 [2], clause 9.7.5.2.3	3.1 dB, $f \leq 3.0\text{GHz}$ 3.3 dB, $3.0\text{GHz} < f \leq 4.2\text{GHz}$ 3.4 dB, $4.2\text{GHz} < f \leq 7.125$ GHz	Formula: Minimum Requirement + TT

6.7.5.4 Additional spurious emissions requirements	See TS 38.104 [2], clause 9.7.5.2.4	2.6 dB, $f \leq 3$ GHz 3.0 dB, $3 \text{ GHz} < f \leq 4.2 \text{ GHz}$ 3.5 dB, $4.2 \text{ GHz} < f \leq 7.125 \text{ GHz}$  For co-existence with PHS: 0 dB  Additional limits for bands n50, n51, n74, n75, n76: 0 dB	Formula: Minimum Requirement + TT
6.7.5.5 Co-location with other base stations	See TS 38.104 [2], clause 9.7.5.2.5	3.1 dB, $f \leq 3.0\text{GHz}$ 3.3 dB, $3.0\text{GHz} < f \leq 4.2\text{GHz}$ 3.4 dB, $4.2\text{GHz} < f \leq 7.125 \text{ GHz}$	Formula: Minimum Requirement + TT
6.8 OTA transmitter intermodulation	See TS 38.104 [2], clause 9.8	0 dB	
NOTE: TT values are applicable for normal condition unless otherwise stated.			

**Table C.1-2: Derivation of test requirements (FR2 OTA transmitter tests)**

Test	Minimum requirement in TS 38.104 [2]	Test Tolerance (TT <sub>OTA</sub> )	Test requirement in the present document
6.2 Radiated transmit power	See TS 38.104 [2], clause 9.2	Normal conditions: 1.7 dB, 24.25 GHz < f ≤ 29.5 GHz 2.0 dB, 37 GHz < f ≤ 43.5 GHz 2.2 dB, 43.5 GHz < f ≤ 48.2 GHz 3.0 dB, 52.6 GHz ≤ f ≤ 71GHz  Extreme conditions: 3.1 dB, 24.25 GHz < f ≤ 29.5 GHz 3.3 dB, 37 GHz < f ≤ 43.5 GHz 3.5 dB, 43.5 GHz < f ≤ 48.2 GHz 3.9 dB, 52.6 GHz ≤ f ≤ 71 GHz	Formula: Upper limit + TT, Lower limit – TT
6.3 OTA base station output power	See TS 38.104 [2], clause 9.3	2.1 dB, 24.25 GHz < f ≤ 29.5 GHz 2.4 dB, 37 GHz < f ≤ 43.5 GHz 2.6 dB, 43.5 GHz < f ≤ 48.2 GHz 3.2 dB, 52.6 GHz ≤ f ≤ 71 GHz	Formula: Upper limit + TT, Lower limit – TT
6.4 OTA output power dynamics	See TS 38.104 [2], clause 9.4	0.4 dB	Formula: Total power dynamic range – TT
6.5.1 OTA transmitter OFF power	See TS 38.104 [2], clause 9.5.2	2.9 dB, 24.25 GHz < f ≤ 29.5 GHz 3.3 dB, 37 GHz < f ≤ 43.5 GHz 3.6 dB, 43.5 GHz < f ≤ 48.2 GHz 5.6 dB, 52.6 GHz ≤ f ≤ 71 GHz	Formula: Minimum Requirement + TT
6.6.2 OTA frequency Error	See TS 38.104 [2], clause 9.6.1	12 Hz	Formula: Frequency Error limit + TT
6.6.3 OTA Modulation quality (EVM)	See TS 38.104 [2], clause 9.6.2	1 %	Formula: EVM limit + TT
6.6.4 OTA time alignment error	See TS 38.104 [2], clause 9.6.3	25 ns	
6.7.2 OTA occupied bandwidth	See TS 38.104 [2], clause 9.7.2	0 Hz	Formula: Minimum Requirement + TT
6.7.3 OTA Adjacent Channel Leakage Power Ratio (ACLR)	See TS 38.104 [2], clause 9.7.3	Relative: 2.3 dB, 24.25 GHz < f ≤ 29.5 GHz 2.6 dB, 37 GHz < f ≤ 43.5 GHz 2.8 dB, 43.5 GHz < f ≤ 48.2 GHz 4.6 dB, 52.6 GHz ≤ f ≤ 71 GHz  Absolute: 2.7 dB, 24.25 GHz < f ≤ 29.5 GHz 2.7 dB, 37 GHz < f ≤ 43.5 GHz 2.9 dB, 43.5 GHz < f ≤ 48.2 GHz 4.7 dB, 52.6 GHz ≤ f ≤ 71 GHz	Formula: Relative limit - TT Absolute limit +TT



6.7.4 OTA operating band unwanted emissions	See TS 38.104 [2], clause 9.7.4	$0 \text{ MHz} \leq \Delta f < 0.1 \cdot \text{BW}_{\text{contiguous}}$ 2.7 dB, 24.25 GHz < f ≤ 29.5 GHz 2.7 dB, 37 GHz < f ≤ 43.5 GHz 2.9 dB, 43.5 GHz < f ≤ 48.2 GHz 4.7 dB, 52.6 GHz ≤ f ≤ 71 GHz  $0.1 \cdot \text{BW}_{\text{contiguous}} \leq \Delta f < \Delta f_{\text{max}}$ 0 dB  For co-existence with Earth Exploration Satellite Service 0 dB	Formula: Minimum Requirement + TT
6.7.5.2 General transmitter spurious emissions requirements Category A	See TS 38.104 [2], clause 9.7.5.3.2	0 dB	Formula: Minimum Requirement + TT
6.7.5.2 General transmitter spurious emissions requirements Category B	See TS 38.104 [2], clause 9.7.5.3.2	0 dB	Formula: Minimum Requirement + TT
6.7.5.4 OTA transmitter spurious emissions, additional requirements	See TS 38.104 [2], clause 9.7.5.3.3	For co-existence with Earth Exploration Satellite Service 0 dB	Formula: Minimum Requirement + TT
NOTE: TT values are applicable for normal condition unless otherwise stated.			

## C.2 Measurement of receiver

**Table C.2-1: Derivation of test requirements (FR1 OTA receiver tests)**

Test	Minimum requirement in TS 38.104 [2]	Test Tolerance (TT <sub>OTA</sub> )	Test requirement in the present document
7.2 OTA sensitivity	See TS 38.104 [2], clause 10.2	1.3 dB, $f \leq 3.0$ GHz 1.4 dB, $3.0 \text{ GHz} < f \leq 4.2 \text{ GHz}$ 1.6 dB, $4.2 \text{ GHz} < f \leq 6.0 \text{ GHz}$ 1.9 dB, $6.0 \text{ GHz} < f \leq 7.125 \text{ GHz}$	Formula: Declared Minimum EIS + TT
7.3 OTA reference sensitivity level	See TS 38.104 [2], clause 10.3	1.3 dB, $f \leq 3.0$ GHz 1.4 dB, $3.0 \text{ GHz} < f \leq 4.2 \text{ GHz}$ 1.6 dB, $4.2 \text{ GHz} < f \leq 6.0 \text{ GHz}$ 1.9 dB, $6.0 \text{ GHz} < f \leq 7.125 \text{ GHz}$	Formula: EIS <sub>REFSENS</sub> + TT
7.4 OTA dynamic range	See TS 38.104 [2], clause 10.4	0.3 dB, $f \leq 7.125 \text{ GHz}$	Formula: Wanted signal power + TT  Interferer signal power unchanged.
7.5.1 OTA adjacent channel selectivity	See TS 38.104 [2], clause 10.5.1	0 dB	Formula: Wanted signal power + TT  Interferer signal power unchanged.
7.5.2 In-band blocking (General)	See TS 38.104 [2], clause 10.5.2	0 dB	Formula: Wanted signal power + TT  Interferer signal power unchanged.
7.5.2 In-band blocking (Narrowband)	See TS 38.104 [2], clause 10.5.2	0 dB	Formula: Wanted signal power + TT  Interferer signal power unchanged.
7.6 OTA out-of-band blocking (General)	See TS 38.104 [2], clause 10.6	0 dB	Formula: Wanted signal power + TT  Interferer signal power unchanged.
7.6 OTA out-of-band blocking (Co-location)	See TS 38.104 [2], clause 10.6	0 dB	Formula: Wanted signal power unchanged  Interferer signal power - TT.
7.7 OTA receiver spurious emissions	See TS 38.104 [2], clause 10.7	0 dB	Formula: Minimum Requirement + TT
7.8 OTA receiver intermodulation	See TS 38.104 [2], clause 10.8	0 dB	Formula: Wanted signal power + TT  Interferer signal power unchanged
7.9 OTA in-channel selectivity	See TS 38.104 [2], clause 10.9	1.7 dB, $f \leq 3.0$ GHz 2.1 dB, $3.0 \text{ GHz} < f \leq 4.2 \text{ GHz}$ 2.4 dB, $4.2 \text{ GHz} < f \leq 6.0 \text{ GHz}$ 2.8 dB, $6.0 \text{ GHz} < f \leq 7.125 \text{ GHz}$	Formula: Wanted signal power + TT  Interferer signal power unchanged

NOTE: TT values are applicable for normal condition unless otherwise stated.

Table C.2-2: Derivation of test requirements (FR2 OTA receiver tests)

Test	Minimum requirement in TS 38.104 [2]	Test Tolerance (TT <sub>OTA</sub> )	Test requirement in the present document
7.3 OTA reference sensitivity level	See TS 38.104 [2], clause 10.3	2.4 dB, 24.25 GHz < f ≤ 33.4 GHz 2.4 dB, 37 GHz < f ≤ 43.5 GHz 3.5 dB, 43.5 GHz < f ≤ 48.2 GHz 3.0 dB, 52.6GHz ≤ f ≤ 71GHz	Formula: EIS <sub>REFSENS</sub> + TT
7.5.1 OTA adjacent channel selectivity	See TS 38.104 [2], clause 10.5.1	0 dB	Formula: Wanted signal power + TT  Interferer signal power unchanged.
7.5.2 In-band blocking	See TS 38.104 [2], clause 10.5.2	0 dB	Formula: Wanted signal power + TT  Interferer signal power unchanged.
7.6 OTA out-of-band blocking	See TS 38.104 [2], clause 10.6	0 dB	Formula: Wanted signal power + TT Interferer signal power unchanged
7.7 OTA receiver spurious emissions	See TS 38.104 [2], clause 10.7	0 dB	Formula: Minimum Requirement + TT
7.8 OTA receiver intermodulation	See TS 38.104 [2], clause 10.8	0 dB	Formula: Wanted signal power + TT  Interferer signal power unchanged.
7.9 OTA in-channel selectivity	See TS 38.104 [2], clause 10.9	3.4 dB, 24.25 GHz < f ≤ 33.4 GHz 3.4 dB, 37 GHz < f ≤ 43.5 GHz 5.1 dB, 43.5 GHz < f ≤ 48.2 GHz 4.0 dB, 52.6GHz ≤ f ≤ 71GHz	Formula: Wanted signal power + TT  Interferer signal power unchanged.
NOTE: TT values are applicable for normal condition unless otherwise stated.			

---

## C.3 Measurement of performance requirements

Table C.3-1: Derivation of test requirements (FR1 OTA performance tests)

Test	Minimum Requirement in TS 38.104 [2]	Test Tolerance (TT <sub>OTA</sub> )	Test requirement in the present document
8.2.1 Performance requirements for PUSCH with transform precoding disabled	See clause 11.2.1.1	0.6 dB	Formula: SNR + TT <sub>OTA</sub> T-put limit unchanged
8.2.2 Performance requirements for PUSCH with transform precoding enabled	See clause 11.2.1.2	0.6 dB	Formula: SNR + TT <sub>OTA</sub> T-put limit unchanged
8.2.3 Performance requirements for UCI multiplexed on PUSCH	See clause 11.2.1.3	0.6 dB	Formula: SNR + TT <sub>OTA</sub> BLER limit unchanged
8.2.4 Performance requirements for PUSCH for high speed train	SNRs as specified	0.3 dB	Formula: SNR + TT T-put limit unchanged
8.2.6 Performance requirements for PUSCH with 0.001% BLER	SNRs as specified	0.3 dB	Formula: SNR + TT + 1dB  1dB is added to the test requirement to facilitate early test pass. The BLER delivered by the device during the test will be lower than the test requirement, which enables compliance to the requirement to be demonstrated with a number of observed block errors lower than a certain threshold.
8.2.7 Performance requirements for PUSCH repetition Type A	See clause 11.2.1.7	0.6 dB	Formula: SNR + TT <sub>OTA</sub> BLER limit unchanged
8.2.8 Performance requirements for PUSCH mapping type B with non-slot transmission	See clause 11.2.1.8	0.6 dB	Formula: SNR + TT <sub>OTA</sub> T-put limit unchanged
8.2.12 Performance requirements for PUSCH TB over Multi-Slots	See clause 11.2.1.12	0.6 dB	Formula: SNR + TT <sub>OTA</sub> T-put limit unchanged
8.2.13 Performance requirements for PUSCH with DM-RS bundling	See clause 11.2.1.13	0.6 dB	Formula: SNR + TT <sub>OTA</sub> T-put limit unchanged
8.2.14 Performance requirements for PUSCH for ATG	See clause 11.2.1.14	0.6 dB	Formula: SNR + TT <sub>OTA</sub> T-put limit unchanged
8.2.15 Performance requirements for PUSCH with enhanced DM-RS	See clause 11.2.1.15	0.6 dB	Formula: SNR + TT <sub>OTA</sub> T-put limit unchanged
8.3.1 Performance requirements for PUCCH format 0	See clause 11.3.1.2	0.6 dB	Formula: SNR + TT <sub>OTA</sub> False ACK limit unchanged Correct ACK limit unchanged
8.3.2 Performance requirements for PUCCH format 1	See clause 11.3.1.3	0.6 dB	Formula: SNR + TT <sub>OTA</sub> False ACK limit unchanged False NACK limit unchanged Correct ACK limit unchanged
8.3.3 Performance requirements for PUCCH format 2	See clause 11.3.1.4	0.6 dB	Formula: SNR + TT <sub>OTA</sub> False ACK limit unchanged Correct ACK limit unchanged UCI BLER limit unchanged
8.3.4 Performance requirements for PUCCH format 3	See clause 11.3.1.5	0.6 dB	Formula: SNR + TT <sub>OTA</sub> UCI BLER limit unchanged
8.3.5 Performance requirements for PUCCH format 4	See clause 11.3.1.6	0.6 dB	Formula: SNR + TT <sub>OTA</sub> UCI BLER limit unchanged
8.3.6 Performance requirements for multi-slot PUCCH	See clause 11.3.1.7	0.6 dB	Formula: SNR + TT <sub>OTA</sub> False ACK limit unchanged False NACK limit unchanged Correct ACK limit unchanged
8.3.11 Performance requirements for PUCCH sub-slot based repetition format 0	See clause 11.3.1.10	0.6dB	Formula: SNR + TT <sub>OTA</sub> False ACK limit unchanged Correct ACK limit unchanged
8.3.12 Performance requirements for PUCCH format 1 with DM-RS bundling	See clause 11.3.1.8	0.6 dB	Formula: SNR + TT <sub>OTA</sub> False ACK limit unchanged False NACK limit unchanged Correct ACK limit unchanged
8.3.13 Performance requirements for PUCCH format 3 with DM-RS bundling	See clause 11.3.1.9	0.6 dB	Formula: SNR + TT <sub>OTA</sub> UCI BLER limit unchanged

8.4.1 PRACH false alarm probability and missed detection	See clause 11.4.1	0.6 dB for fading cases 0.3 dB for AWGN cases	Formula: $SNR + TT_{OTA}$ PRACH False detection limit unchanged PRACH detection limit unchanged
8.4.2 Performance requirements for PRACH for high speed train	SNRs as specified	0.6 dB for fading cases 0.3 dB for AWGN cases	Formula: $SNR + TT$ PRACH False detection limit unchanged PRACH detection limit unchanged
8.2.5 Performance requirements for UL timing adjustment	See clause 11.2.1.5	0.3 dB for AWGN cases	Formula: $SNR + TT_{OTA}$ T-put limit unchanged
NOTE: TT values are applicable for normal condition unless otherwise stated.			

**Table C.3-2: Derivation of test requirements (FR2 OTA performance tests)**

Test	Minimum requirement in TS 38.104 [2]	Test Tolerance ( $TT_{OTA}$ )	Test requirement in the present document
8.2.1 Performance requirements for PUSCH with transform precoding disabled	See clause 11.2.2.1	0.6 dB	Formula: $SNR + TT_{OTA}$ T-put limit unchanged
8.2.2 Performance requirements for PUSCH with transform precoding enabled	See clause 11.2.2.2	0.6 dB	Formula: $SNR + TT_{OTA}$ T-put limit unchanged
8.2.3 Performance requirements for UCI multiplexed on PUSCH	See clause 11.2.2.3	0.6 dB	Formula: $SNR + TT_{OTA}$ BLER limit unchanged
8.2.7 Performance requirements for PUSCH repetition Type A	See clause 11.2.2.4	0.6 dB	Formula: $SNR + TT_{OTA}$ BLER limit unchanged
8.2.8 Performance requirements for PUSCH mapping Type B with non-slot transmission	See clause 11.2.2.5	0.6 dB	Formula: $SNR + TT_{OTA}$ T-put limit unchanged
8.2.12 Performance requirements for PUSCH TB over Multi-Slots	See clause 11.2.2.9	0.6 dB	Formula: $SNR + TT_{OTA}$ T-put limit unchanged
8.2.13 Performance requirements for PUSCH with DM-RS bundling	See clause 11.2.2.10	0.6 dB	Formula: $SNR + TT_{OTA}$ T-put limit unchanged
8.3.1 Performance requirements for PUCCH format 0	See clause 11.3.2.2	0.6 dB	Formula: $SNR + TT_{OTA}$ False ACK limit unchanged Correct ACK limit unchanged
8.3.2 Performance requirements for PUCCH format 1	See clause 11.3.2.3	0.6 dB	Formula: $SNR + TT_{OTA}$ False ACK limit unchanged False NACK limit unchanged Correct ACK limit unchanged
8.3.3 Performance requirements for PUCCH format 2	See clause 11.3.2.4	0.6 dB	Formula: $SNR + TT_{OTA}$ False ACK limit unchanged Correct ACK limit unchanged UCI BLER limit unchanged
8.3.4 Performance requirements for PUCCH format 3	See clause 11.3.2.5	0.6 dB	Formula: $SNR + TT_{OTA}$ UCI BLER limit unchanged
8.3.5 Performance requirements for PUCCH format 4	See clause 11.3.2.6	0.6 dB	Formula: $SNR + TT_{OTA}$ UCI BLER limit unchanged
8.3.12 Performance requirements for PUCCH format 1 with DM-RS bundling	See clause 11.3.2.7	0.6 dB	Formula: $SNR + TT_{OTA}$ False ACK limit unchanged False NACK limit unchanged Correct ACK limit unchanged
8.3.13 Performance requirements for PUCCH format 3 with DM-RS bundling	See clause 11.3.2.8	0.6 dB	Formula: $SNR + TT_{OTA}$ UCI BLER limit unchanged
8.4.1 PRACH false alarm probability and missed detection	See clause 11.4.2	0.6 dB for fading cases 0.3 dB for AWGN cases	Formula: $SNR + TT_{OTA}$ PRACH False detection limit unchanged PRACH detection limit unchanged
NOTE: TT values are applicable for normal condition unless otherwise stated.			

---

## Annex D (normative): Calibration

OTA test requirements specific and OTA measurement chamber specific calibration (and measurement) procedures were captured in TR 37.941 [29] for the following requirements sets:

- TX and Rx directional requirements
- In-band and out-of-band TRP requirements
- Co-location requirements
- In-band and out-of-band blocking requirements

All the calibrations procedures in TR 37.941 [29] for FR1 are assumed to be also applicable to *BS type 1-H* and *BS type 1-O* for the FR1 frequency range (i.e. up to 6 GHz), as well as for *BS type 2-O* for the FR2 frequency range, unless stated otherwise.

## Annex E (informative): OTA measurement system set-up

### E.1 Transmitter

#### E.1.1 Radiated transmit power, OTA output power dynamics, OTA transmitted signal quality, OTA occupied bandwidth, and OTA transmit ON/OFF power (*BS type 2-0*)

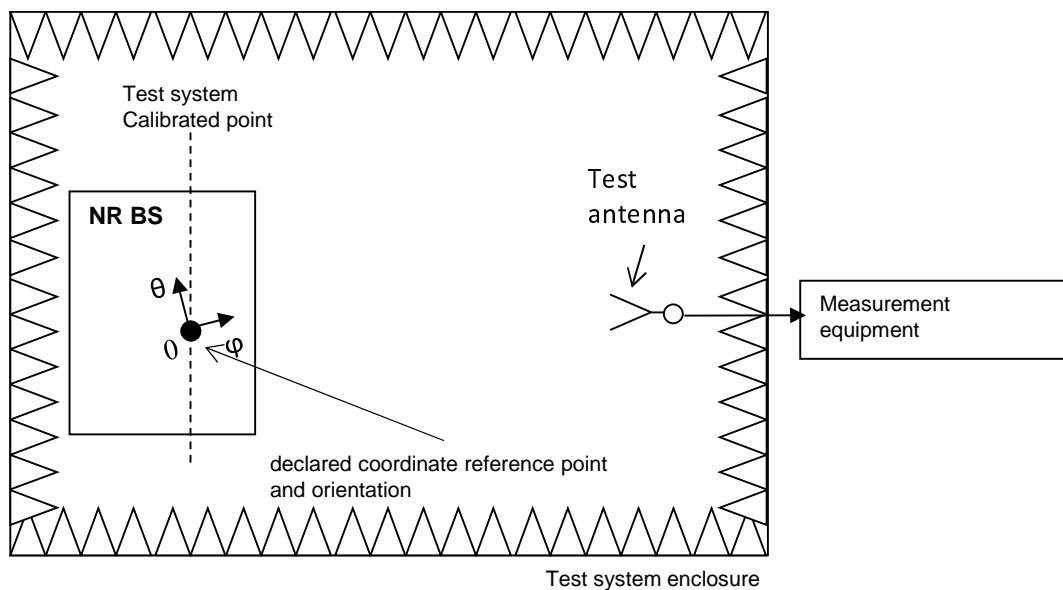
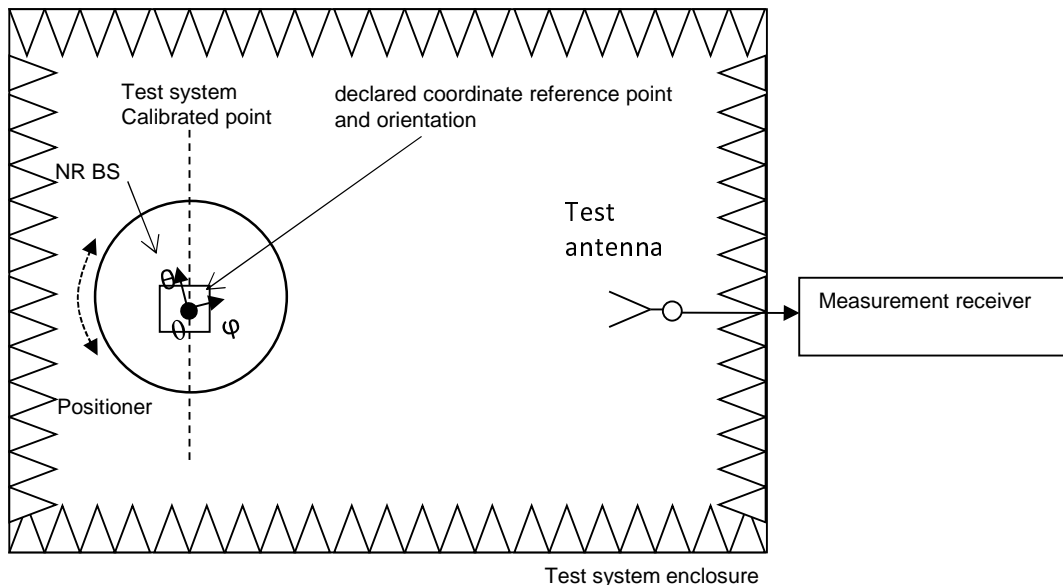

**Figure E.1.1-1: Measurement set up for radiated transmit power, OTA output power dynamics, OTA transmitted signal quality, OTA occupied bandwidth, and OTA transmit ON/OFF power (*BS type 2-0*)**

The OTA chamber shown in figure E.1.1-1 is intended to be generic and can be replaced with any suitable OTA chamber (Far field anechoic chamber, CATR, Near field chamber, PWS, etc.).



### E.1.2 OTA base station output power, OTA ACLR, OTA operating band unwanted emissions



**Figure E.1.2-1: Measurement set up for OTA base station output power, OTA ACLR, OTA operating band unwanted emissions**

The OTA chamber shown in figure E.1.2-1 is intended to be generic and can be replaced with any suitable OTA chamber (Far field anechoic chamber, CATR, Near field chamber, PWS, etc.).

### E.1.3 OTA spurious emissions

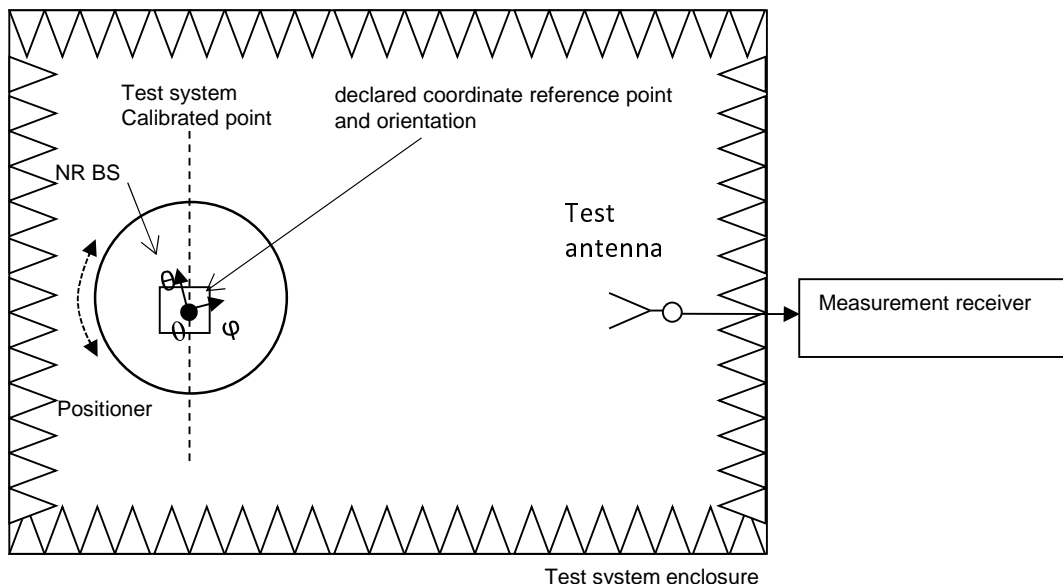

**Figure E.1.3-1: Measurement set up for OTA spurious emissions**

The OTA chamber shown in figure E.1.3-1 is intended to be generic and can be replaced with any suitable OTA chamber (Far field anechoic chamber, CATR, etc.).

### E.1.4 OTA co-location emissions, OTA transmit ON/OFF power (BS type 1-O)

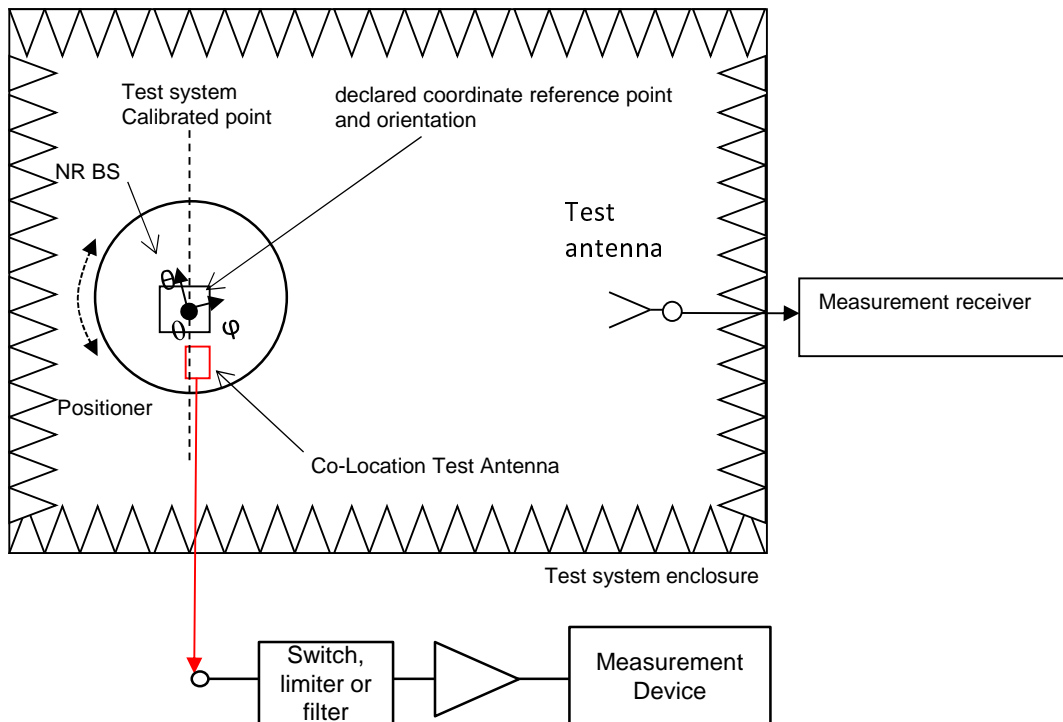
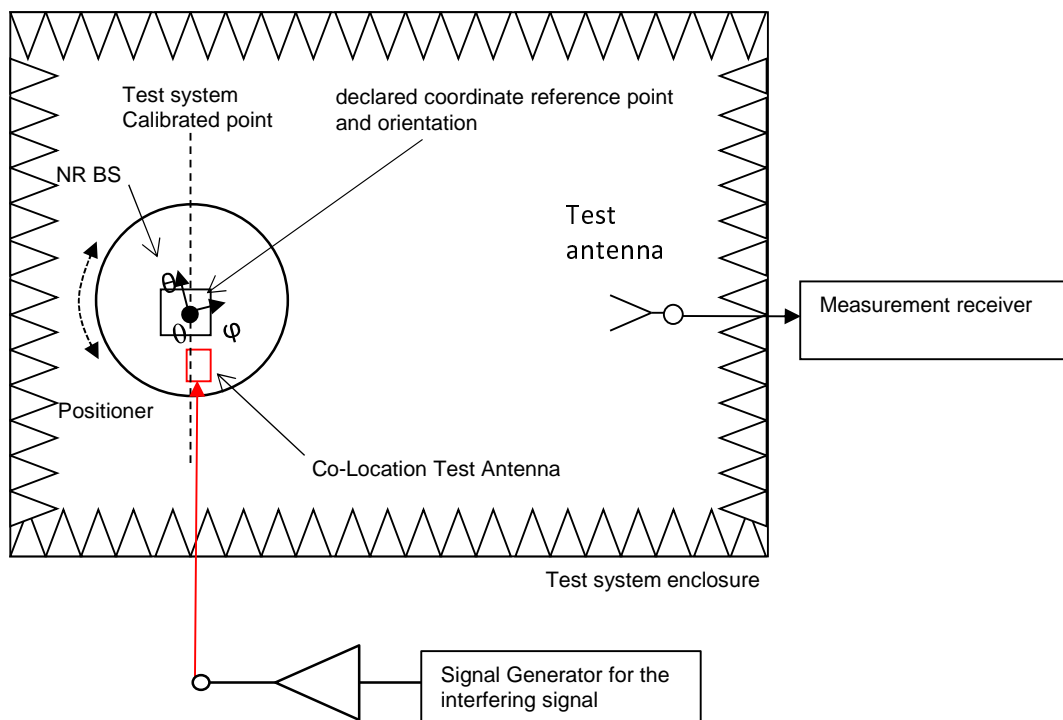

**Figure E.1.4-1: Measurement set up for OTA co-location emissions, OTA transmit ON/OFF power (BS type 1-O)**

The OTA chamber shown in figure E.1.4-1 is intended to be generic and can be replaced with any suitable OTA chamber (Far field anechoic chamber, CATR, Near field chamber, PWS (NOTE), etc.).

NOTE: The maximum rated Power Density (PD) per section of the PWS area (e.g. dBm/cm<sup>2</sup>) might be restricted depending on the implementation. This Power Density at a specific reference plane can be calculated for each transmitter as a function of the total radiated power, the test distance and the radiation pattern of the transmitter.

## E.1.5 OTA transmitter intermodulation



**Figure E.1.5-1: Measurement set up for OTA transmitter intermodulation**

The OTA chamber shown in figure E.1.5-1 is intended to be generic and can be replaced with any suitable OTA chamber (Far field anechoic chamber, CATR, PWS (NOTE), etc.). When injecting the interferer signal into the CLTA ports, a splitter might be needed. For testing emission far out-of-band an additional test antenna might be needed.

**NOTE:** The maximum rated Power Density (PD) per section of the PWS area (e.g. dBm/cm<sup>2</sup>) might be restricted depending on the implementation. This Power Density at a specific reference plane can be calculated for each transmitter as a function of the total radiated power, the test distance and the radiation pattern of the transmitter.

## E.2 Receiver

### E.2.1 OTA sensitivity and OTA reference sensitivity level

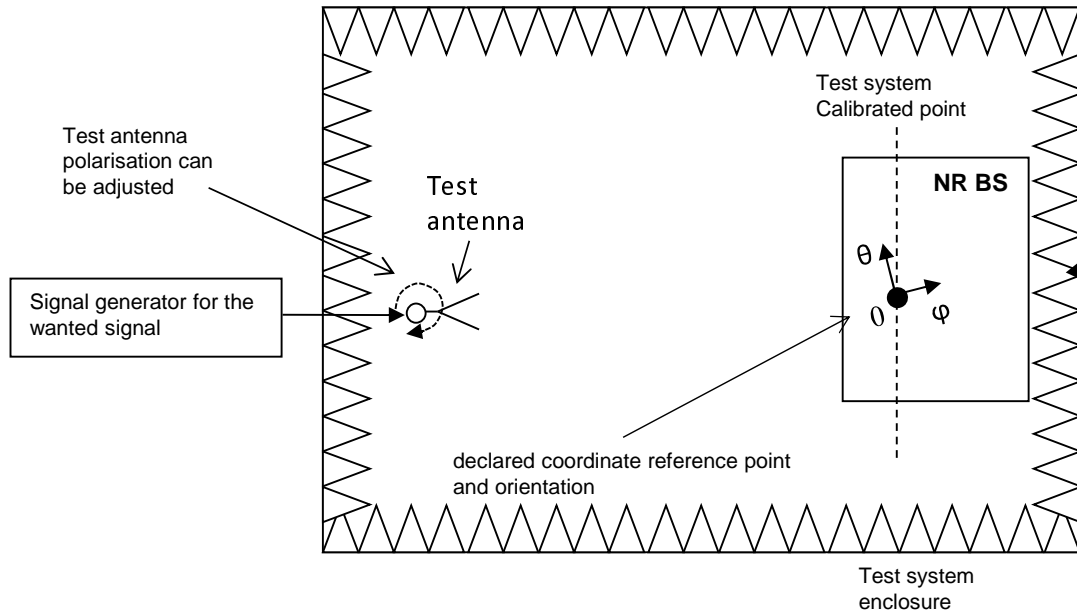

**Figure E.2.1-1: Measurement set up for OTA sensitivity and OTA reference sensitivity level**

The OTA chamber shown in figure E.2.1-1 is intended to be generic and can be replaced with any suitable OTA chamber (Far field anechoic chamber, CATR, PWS, etc.).

### E.2.2 OTA dynamic range

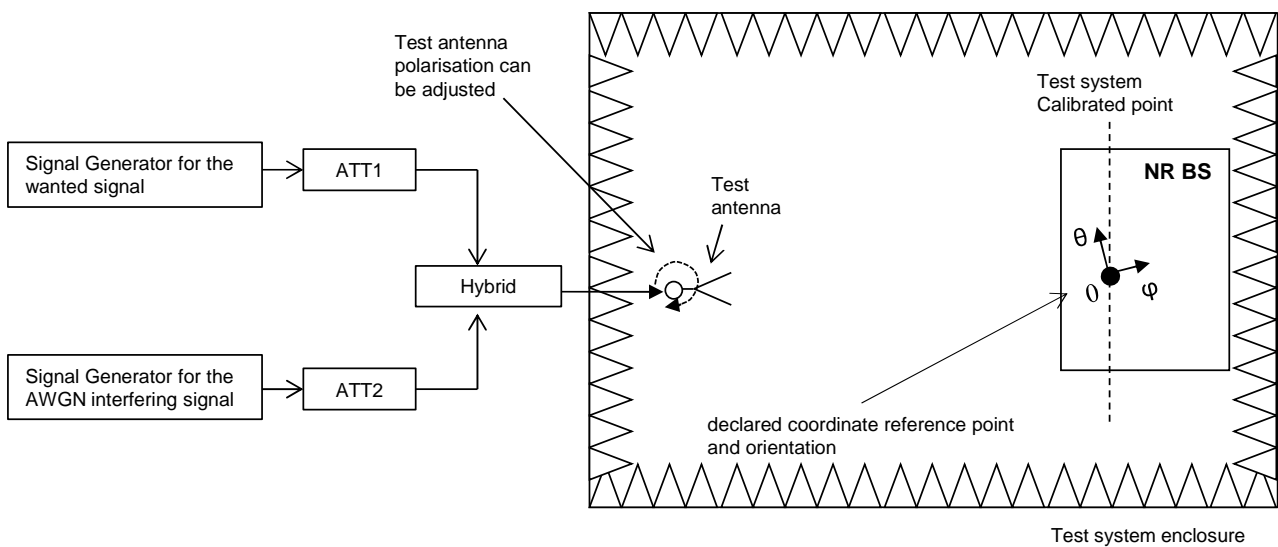

**Figure E.2.2-1: Measurement set up for OTA dynamic range**

The OTA chamber shown in figure E.2.2-1 is intended to be generic and can be replaced with any suitable OTA chamber (Far field anechoic chamber, CATR, PWS, etc.).

### E.2.3 OTA adjacent channel selectivity, general OTA blocking, and OTA narrowband blocking

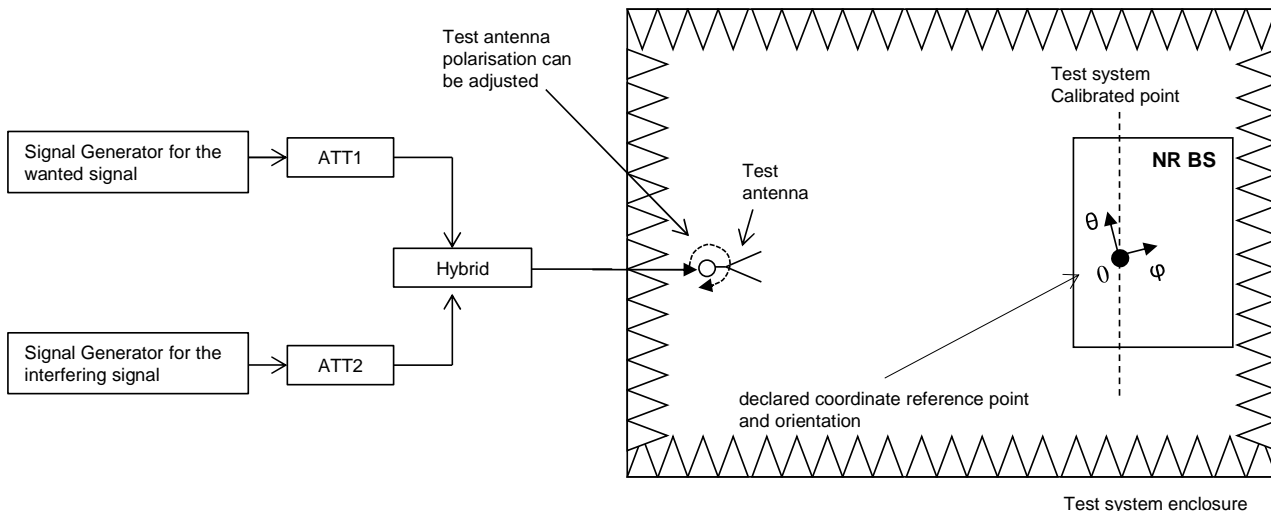

**Figure E.2.3-1: Measurement set up for OTA ACS and OTA narrowband blocking**

The OTA chamber shown in figure E.2.3-1 is intended to be generic and can be replaced with any suitable OTA chamber (Far field anechoic chamber, CATR, PWS, etc.).

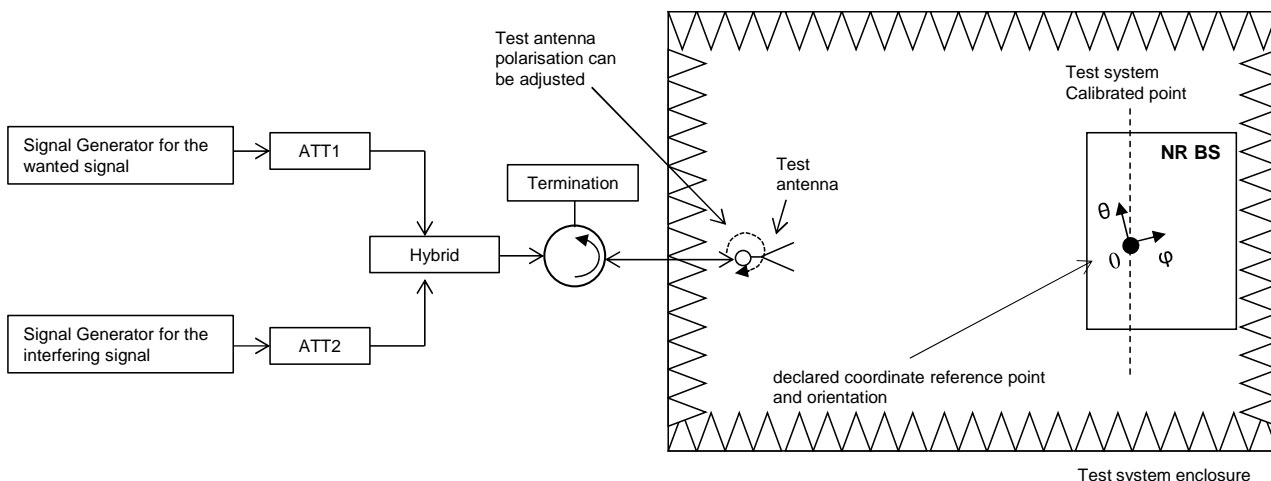
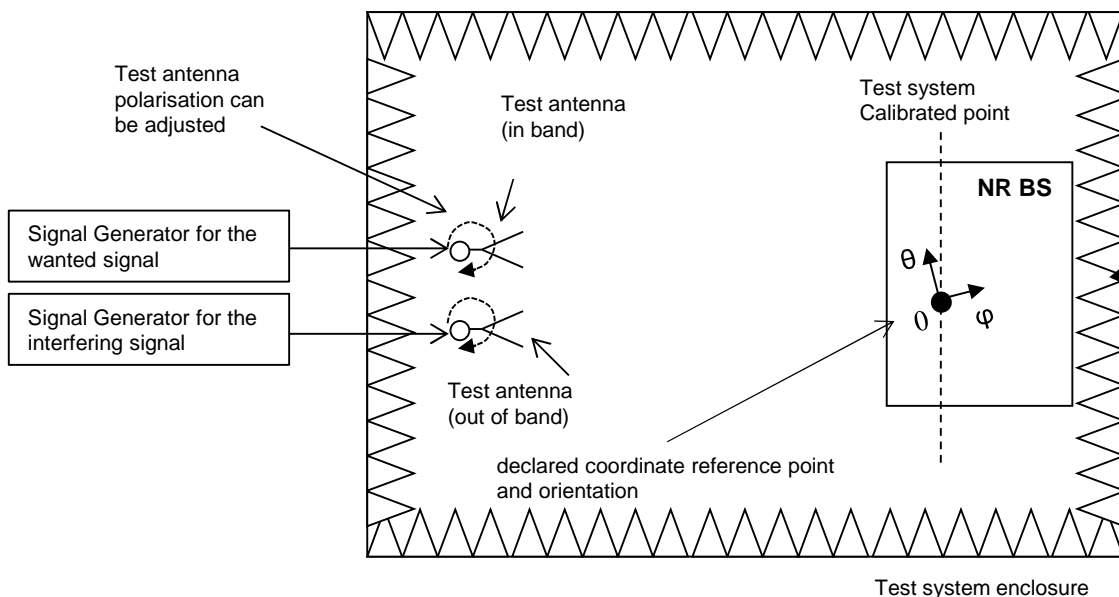

**Figure E.2.3-2: Measurement set up for general OTA blocking**

The OTA chamber shown in figure E.2.3-2 is intended to be generic and can be replaced with any suitable OTA chamber (Far field anechoic chamber, CATR, PWS, etc.).

## E.2.4 OTA blocking

### E.2.4.1 General OTA out-of-band blocking



**Figure E.2.4.1-1: Measurement set up for general OTA out-of-band blocking**

The OTA chamber shown in figure E.2.4.1-1 is intended to be generic and can be replaced with any suitable OTA chamber (Far field anechoic chamber, CATR, PWS, etc.).

### E.2.4.2 OTA co-location blocking

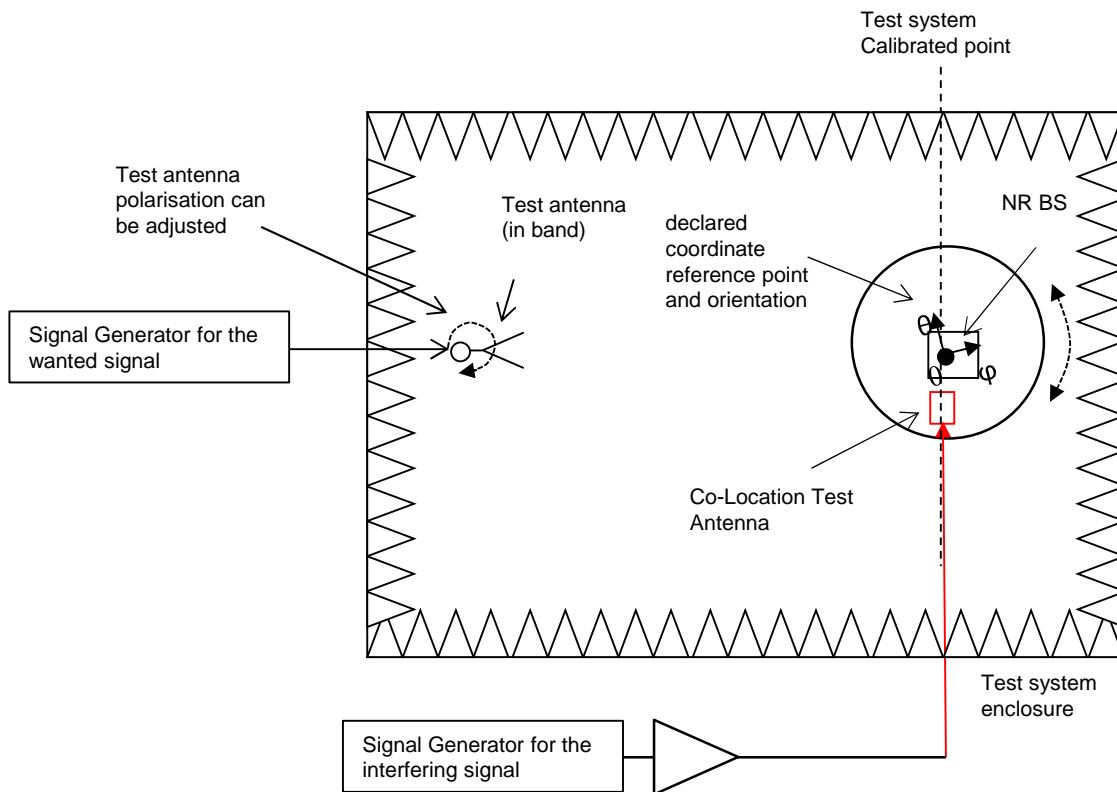

**Figure E.2.4.2-1: Measurement set up for OTA co-location blocking**

The OTA chamber shown in figure E.2.4.2-1 is intended to be generic and can be replaced with any suitable OTA chamber (Far field anechoic chamber, CATR, PWS (NOTE), etc.). For testing blocking far out-of-band several CLTAs might be needed.

NOTE: The maximum rated Power Density (PD) per section of the PWS area (e.g. dBm/cm<sup>2</sup>) might be restricted depending on the implementation. This Power Density at a specific reference plane can be calculated for each transmitter as a function of the total radiated power, the test distance and the radiation pattern of the transmitter.

### E.2.5 OTA receiver spurious emissions

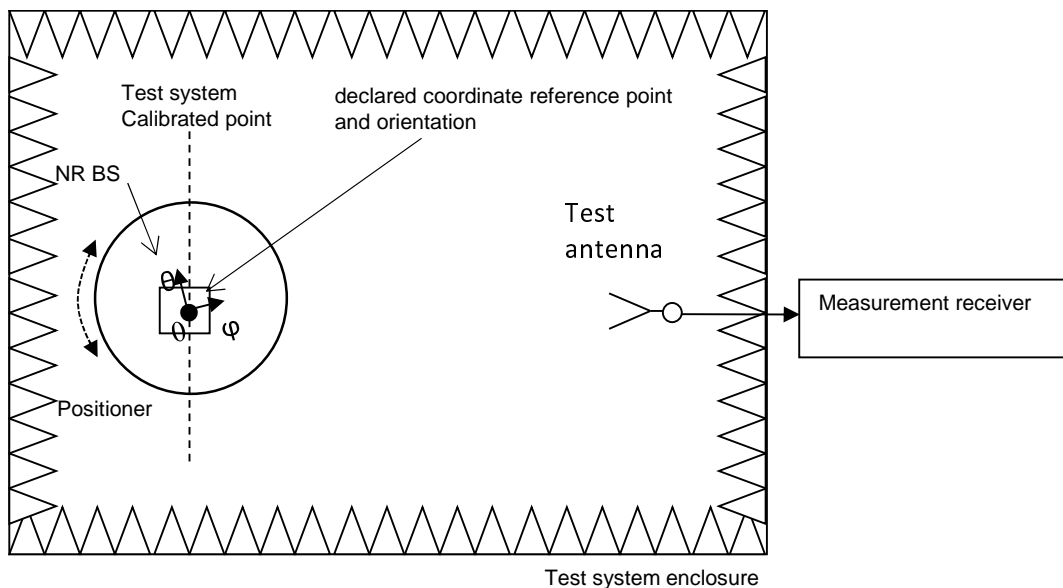

Figure E.2.5-1: Measurement set up for OTA receiver spurious emissions

The OTA chamber shown in figure E.2.5-1 is intended to be generic and can be replaced with any suitable OTA chamber (Far field anechoic chamber, CATR, etc.).

### E.2.6 OTA receiver intermodulation

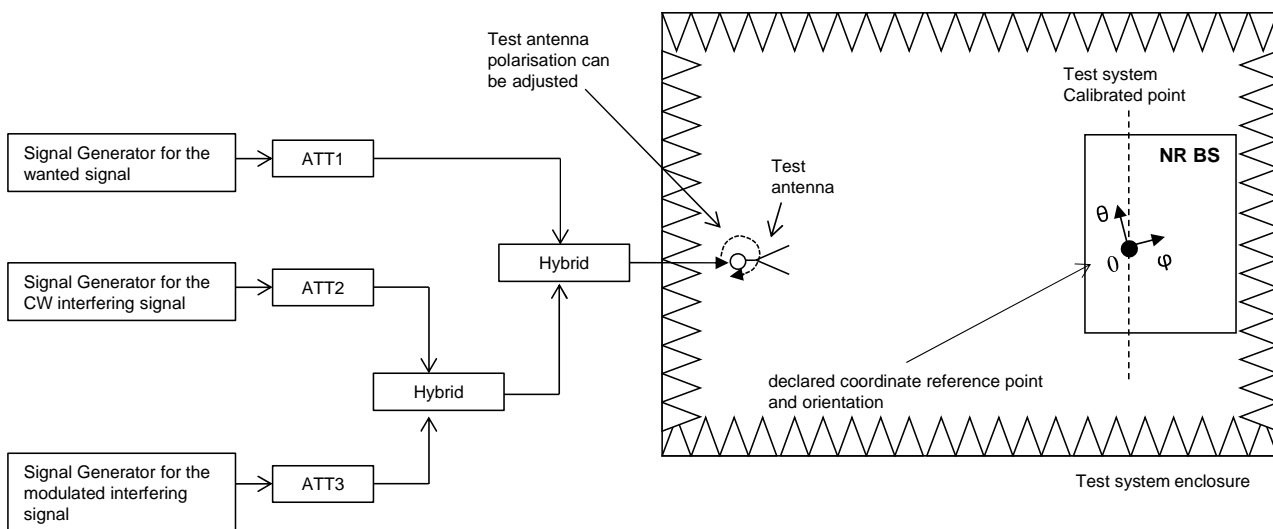

Figure E.2.6-1: Measurement set up for OTA receiver intermodulation

The OTA chamber shown in figure E.2.6-1 is intended to be generic and can be replaced with any suitable OTA chamber (Far field anechoic chamber, CATR, PWS, etc.).

### E.2.7 OTA in-channel selectivity

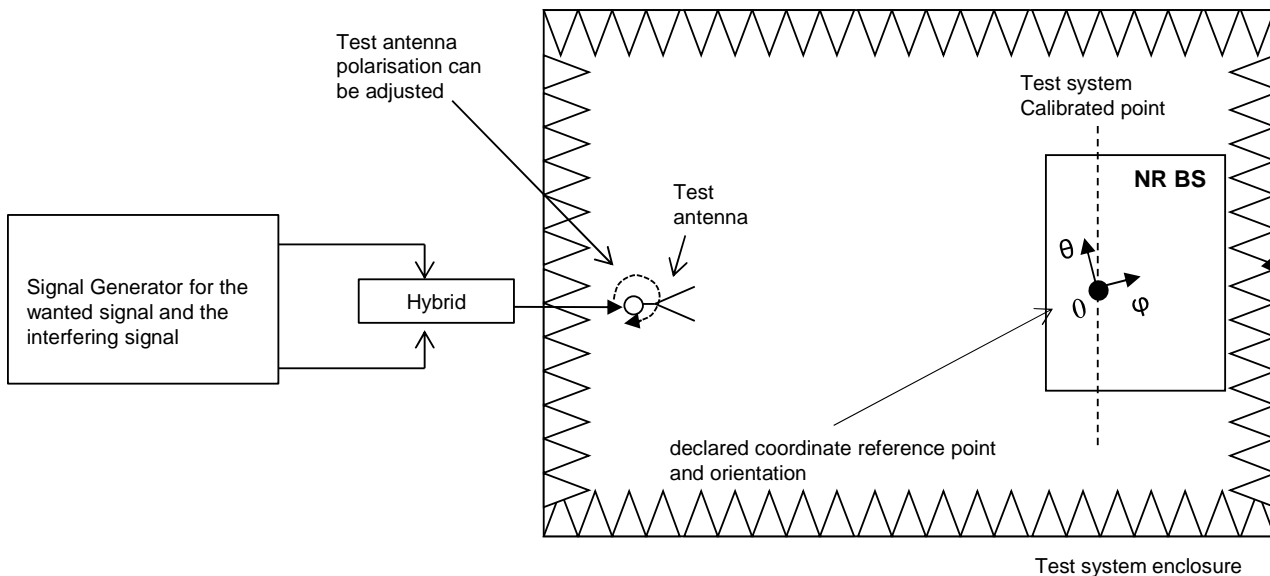

Figure E.2.7-1: Measurement set up for OTA in-channel selectivity

The OTA chamber shown in figure E.2.7-1 is intended to be generic and can be replaced with any suitable OTA chamber (Far field anechoic chamber, CATR, PWS, etc.).

## E.3 Performance requirements

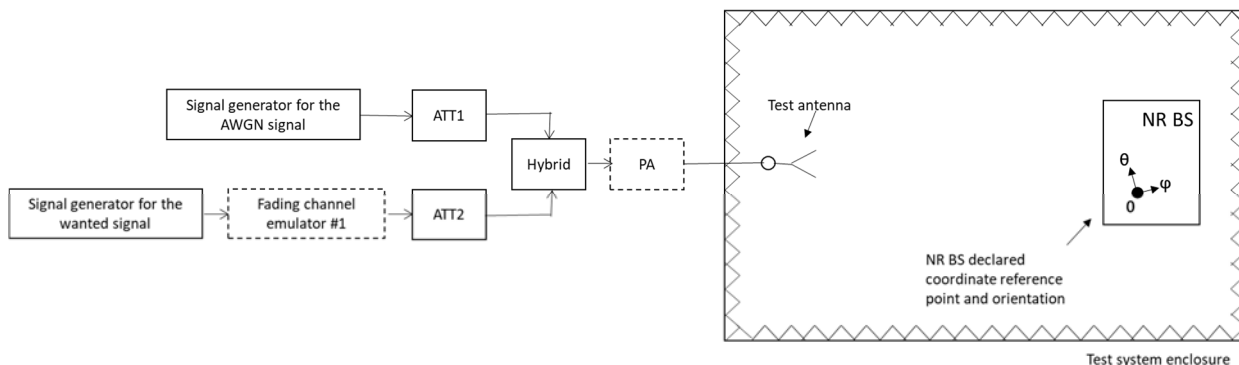

Figure E.3-1: Measurement set up for single TX, single demodulation branch radiated performance requirements



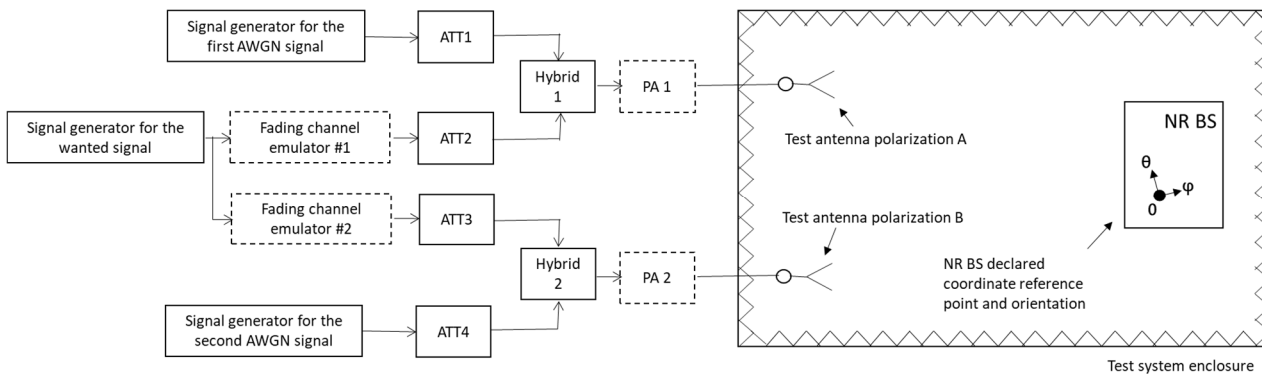

Figure E.3-2: Measurement set up for single TX, dual polarization radiated performance requirements

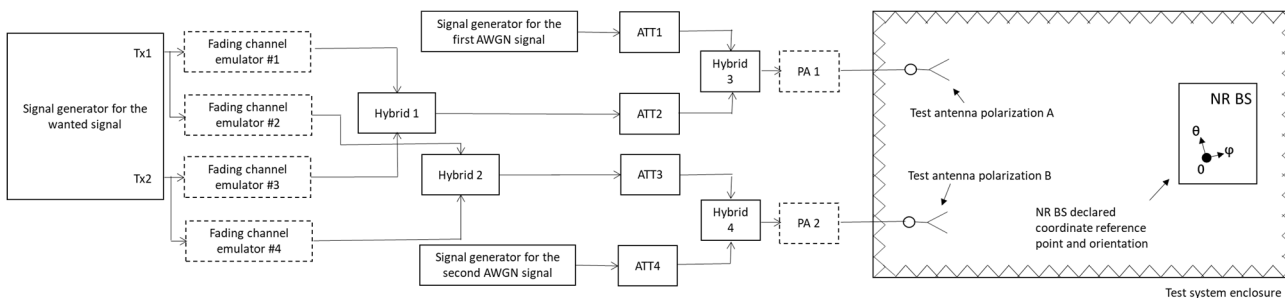

Figure E.3-3: Measurement set up for dual TX, dual polarization radiated performance requirements

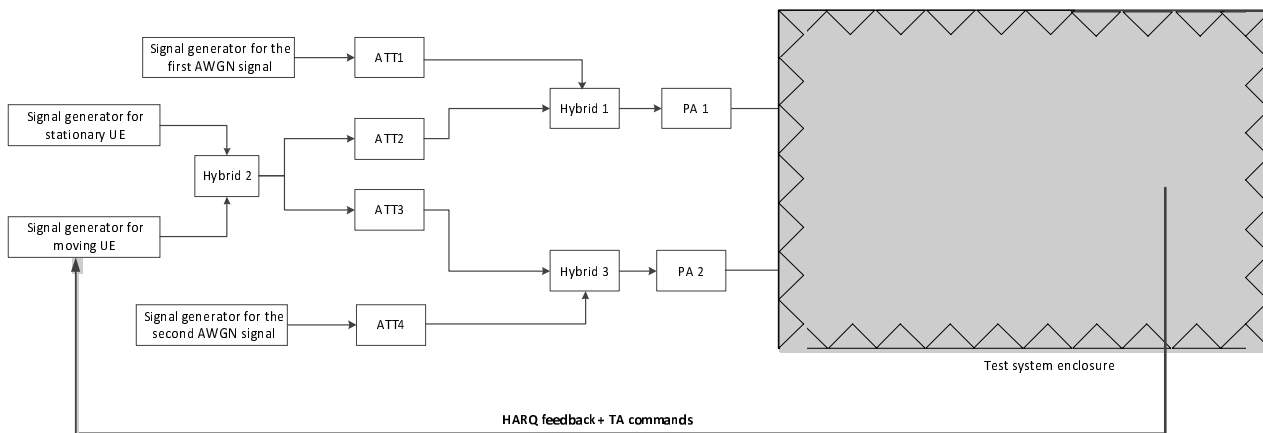

Figure E.3-4: Measurement set up for UL timing adjustment, single TX, dual polarization radiated performance requirements

The OTA chambers shown in figures E.3-1, E.3-2, E.3-3 and E.3-4 are intended to be generic and can be replaced with any suitable OTA chamber (e.g. far field anechoic chamber, CATR, etc.). The PA(s) depicted in figures E.3-1, E.3-2, E.3-3 and E.3-4 is optional. Fading channel emulators are included when needed according to the requirement description.

NOTE: The HARQ Feedback (only for PUSCH) could be done as an RF feedback or as a digital feedback. The HARQ Feedback should be error free.

Annex F (normative):  
Void

# Annex G (informative): Transmitter spatial emissions declaration

## G.1 General

The transmitter spatial emission declaration is an optional declaration which provides additional information on the power level of emission in the intended (in cell) spatial directions and the unintended (out of cell) spatial directions. The declarations are only valid when the beam is configured in one of the EIRP conformance directions.

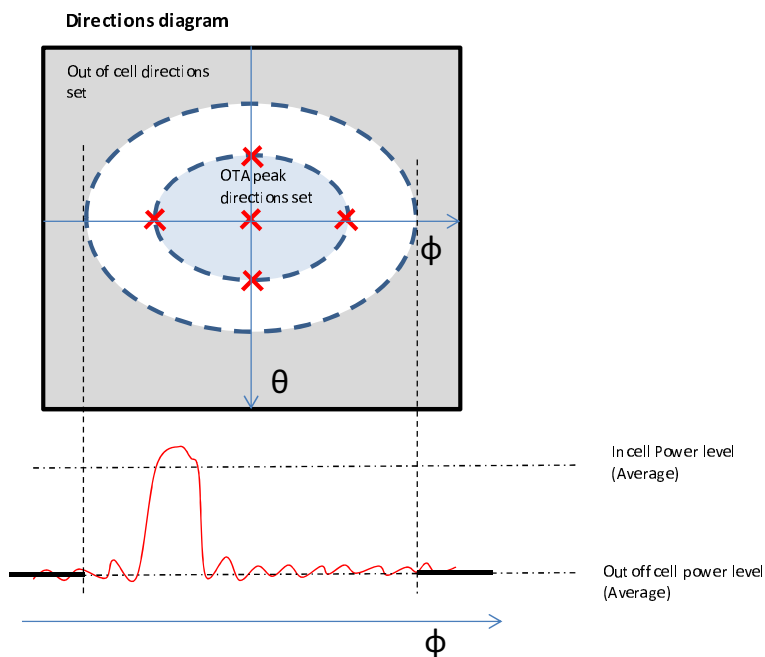

**Figure G.1-1: Example of out of cell directions set and declared single beam at a single extreme steering direction**

The declaration of unwanted spatial emission may in many circumstances not directly relate to system performance on its own. This is because it is often not possible to differentiate wanted and unwanted radiation, and furthermore because the benefits of optimizing beamforming performance may outweigh the impacts of "unwanted" radiation, leading to systems with apparently higher unwanted radiation also providing superior throughput performance. System performance should additionally be characterized taking all factors into account.

## G.2 Declarations

**Table G.2-1: Optional manufacturer declarations**

Declaration identifier	Declaration	Description
DE.1	Out of cell directions set	The set of directions which are outside the intended directions of radiation or outside the wanted cell. Declared per operating band.
DE.2	Out of cell power level	Declared in band average power inside each of the out of cell directions set(s) (DE.1) declared for each of the 5 conformance directions (D.8, D.10)
DE.3	In cell power level	Declared in band average power outside the out of cell directions set(s) (DE.1) declared for each of the 5 conformance directions (D.8, D.10)
DE.4	Average out of cell power level	Declared in band average power inside each of the out of cell directions set(s) (DE.1) averaged over the 5 conformance directions (D.8, D.10).
DE.5	Average in cell power level	Declared in band average power inside each of the out of cell directions set(s) (DE.1) averaged over the 5 conformance directions (D.8, D.10)

NOTE 1: The declaration of unwanted spatial emission may in many circumstances not directly relate to system performance on its own. This is because it is often not possible to differentiate wanted and unwanted radiation, and furthermore because the benefits of optimizing beamforming performance may outweigh the impacts of "unwanted" radiation, leading to systems with apparently higher unwanted radiation also providing superior throughput performance. System performance should additionally be characterized taking all factors into account.

NOTE 2: The average out of cell power level reflects the impact of out of cell radiation on other cells more accurately than the out of cell power level for individual test beams.

---

## Annex H (normative): Characteristics of the interfering signals

The interfering signal shall be a PUSCH containing data and DMRS symbols. Normal cyclic prefix is used. The data content shall be uncorrelated to the wanted signal and modulated according to clause 6 of TS 38.211 [20]. Mapping of PUSCH modulation to receiver requirement are specified in table H-1.

**Table H-1: Modulation of the interfering signal**

<b>Receiver requirement</b>	<b>Modulation</b>
OTA in-channel selectivity	16QAM
OTA adjacent channel selectivity and narrow-band blocking	QPSK
General OTA blocking	QPSK
OTA receiver intermodulation	QPSK

# Annex I (normative): TRP measurement procedures

## I.1 General

The annex describes various procedures for BS OTA TRP measurements. These procedures can provide either an accurate or an over-estimate of TRP values. The procedures for an accurate estimate can be applied to all TRP requirements. However, if a TRP requirement does not need accurate TRP estimate then the procedures for over-estimate of TRP may be used in order to have a reasonable OTA test time. Pre-scan does not provide an accurate TRP estimate or over-estimate of TRP. Pre-scan is a fast but coarse method that is used to identify the spurious emission frequencies with emission power as described in annex I.13. A sequential measurement is then made at the emission frequencies, to assess the TRP as described in annex I.2 to annex I.9.

When making TRP measurements the alignment between EUT and measurement antenna is important to achieve expected measurement uncertainty:

1. The measurement antenna needs to be aligned tangential to the measurement surface forming a sphere around the EUT, in order to correctly measure the TRP properly.
2. Test methods described in clauses I.5.1, I.5.2, I.10, I.11 and I.12 require angular alignment between the selected measurement grid and EUT radiation pattern in order to measure peak values in the main beams. Angular misalignment can lead to differences in the actual and measured angular positions of the intended maximum EIRP.
3. Test methods described in clause I.5.3, I.6 and I.9 are designed to be independent of rotations of the angular grid, and hence angular alignment between the measurement grid and EUT is not needed.

## I.2 Spherical equal angle grid

### I.2.1 General

$TRP_{Estimate}$  is defined as

$$TRP_{Estimate} = \frac{\pi}{2NM} \sum_{n=0}^{N-1} \sum_{m=0}^{M-1} EIRP(\theta_n, \phi_m) \sin \theta_n$$

when EIRP measurements is used or as

$$TRP_{Estimate} = 4\pi d^2 \frac{\pi}{2NM} \sum_{n=0}^{N-1} \sum_{m=0}^{M-1} P_D(\theta_n, \phi_m) \sin \theta_n$$

when power density measurements are used, and  $d$  is the test distance.  $N$  and  $M$  are the number of samples in the  $\theta$  and  $\phi$  angles. Each  $(\theta_n, \phi_m)$  is a sampling point. The sampling angular intervals for  $\theta$  and  $\phi$  angles are  $\Delta\theta = \frac{\pi}{N}$  and  $\Delta\phi = \frac{2\pi}{M}$ . The sampling intervals  $\Delta\theta$  and  $\Delta\phi$  are described in I.2.2.

### I.2.2 Reference angular step criteria

The reference angular steps  $\Delta\phi_{ref}$  and  $\Delta\theta_{ref}$  in degrees are defined as:

$$\Delta\phi_{ref} = \min\left(\frac{180^\circ}{\pi} \frac{\lambda}{D_{cyl}}, 15^\circ\right)$$

$$\Delta\theta_{ref} = \min\left(\frac{180^\circ}{\pi} \frac{\lambda}{D}, 15^\circ\right)$$

The upper limit for these reference angular steps of  $15^\circ$  ensures a low Summation Error (SE) when  $\lambda$  is large compared to the EUT dimensions.

$D_{\text{cyl}}$  and  $D$  are calculated as:

$$D_{\text{cyl}} = \sqrt{d^2 + w^2}$$

$$D = \sqrt{d^2 + w^2 + h^2}$$

The definition of  $d$ ,  $w$  and  $h$  is shown in figure I.2.2-1. The radiation source can be EUT antenna array or the whole of EUT.

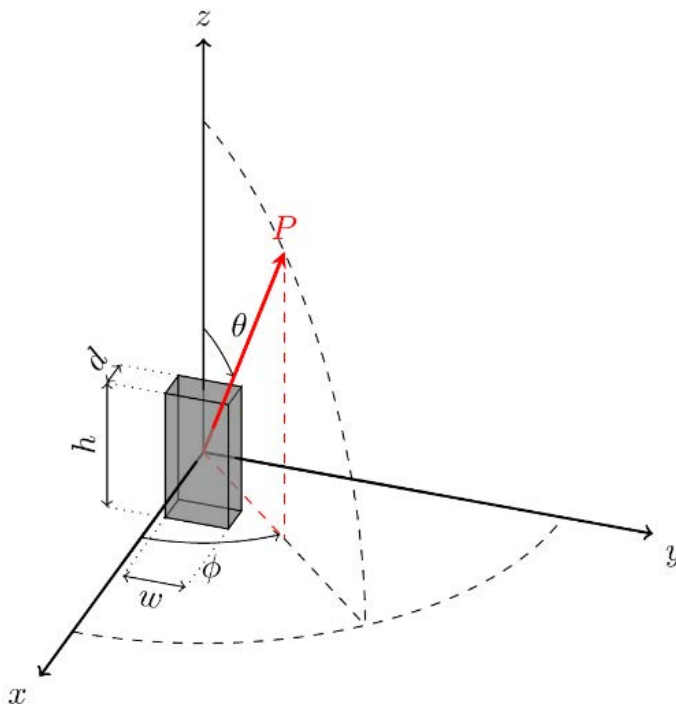

**Figure I.2.2-1: Dimensions of a radiation source: depth (d), width (w) and height (h)**

Optionally, in the case of Uniform Linear Array (ULA), when  $d$  is negligible ( $d \approx 0$ ) and the EUT is mounted along the  $yz$  plane as shown in figure I.2.2-2, the reference angular steps, in degrees, can be determined by

$$\Delta\theta_{ref} = \min\left(\frac{180^\circ}{\pi} \arcsin\left(\frac{\lambda}{D_z}\right), 15^\circ\right)$$

$$\Delta\phi_{ref} = \min\left(\frac{180^\circ}{\pi} \arcsin\left(\frac{\lambda}{D_y}\right), 15^\circ\right)$$

Where  $D_y$  is the length of radiating parts of EUT along  $y$ -axis,  $D_z$  is the length of radiating parts of EUT along the  $z$ -axis and  $\lambda$  is wavelength for the measured frequency.

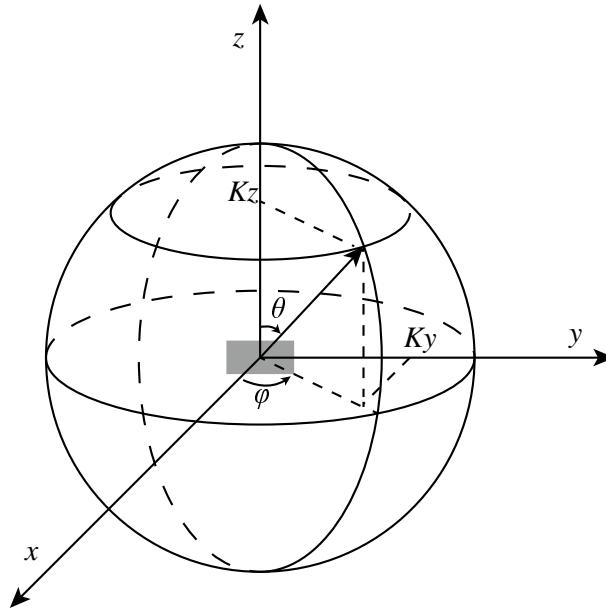

**Figure I2.2-2: Spherical coordinate for OTA conformance testing of EUT**

Where due to practical reasons such as time constraints or turn-table precision, measurement with the reference steps is not practical, sparser grids can be used. Use of sparse grids can lead to errors in TRP assessment. In order to characterize these errors, the SF (sparsity factor) of the grid is defined as

$$SF = \max\left(\frac{\Delta\theta_{grid}}{\Delta\theta_{ref}}, \frac{\Delta\phi_{grid}}{\Delta\phi_{ref}}\right)$$

Where  $\Delta\theta_{grid}$  and  $\Delta\phi_{grid}$  are the actual angular steps used in the measurement.

Alternatively, when EUT radiating dimensions are not known, for each frequency within the *downlink operating band* including  $\Delta f_{OBUE}$ , the reference angular steps can be specified in terms of the *beamwidth* of the wanted signal as

$$\Delta\phi_{ref} = \frac{\lambda}{\lambda_0} BeW_{\phi}$$

$$\Delta\theta_{ref} = \frac{\lambda}{\lambda_0} BeW_{\theta}$$

where  $\lambda_0$  is the wavelength of the wanted signal, and  $BeW_{\phi}$  and  $BeW_{\theta}$  are the *beamwidth* of the wanted signal in the  $\phi$ -axis and  $\theta$ -axis, respectively.

$BeW_{\phi}$  and  $BeW_{\theta}$  may be set to *beamwidth* declared for the OTA BS radiated transmit power requirement provided the same *beam* is applied to test in-band TRP requirements.

NOTE: *Beamwidth* is approximately equal to half the first-null beam width.

## I.3 Spherical equal area grid

$TRP_{Estimate}$  is defined as

$$TRP_{Estimate} = \frac{1}{N} \sum_{n=1}^N EIRP(\theta_n, \phi_n)$$

$N$  is the total number of samples and specified as

$$N \geq \frac{4\pi}{\Delta\theta_{ref} \Delta\phi_{ref}}$$

The sampling intervals  $\Delta\theta_{ref}$  and  $\Delta\phi_{ref}$  are described in annex I.2.2. Each  $(\theta_n, \phi_n)$  is a sampling point.



## I.4 Spherical Fibonacci grid

$TRP_{Estimate}$  is defined as

$$TRP_{Estimate} = \frac{1}{N} \sum_{n=0}^{N-1} EIRP(\theta_n, \phi_n)$$

$N$  is the total number of samples and specified as

$$N \geq \frac{4\pi}{\Delta\theta_{ref} \Delta\phi_{ref}}$$

The sampling intervals  $\Delta\theta_{ref}$  and  $\Delta\phi_{ref}$  are described in annex I.2.2. Each  $(\theta_n, \phi_n)$  is a sampling point, where  $\theta_n$  and  $\phi_n$ , in degrees, are defined as:

$$\theta_n = \cos^{-1} \left( 1 - \frac{2n+1}{N} \right)$$

$$\phi_n = \frac{360^\circ n}{\Psi}, \quad \Psi = \frac{1 + \sqrt{5}}{2}$$

## I.5 Orthogonal cut grid

### I.5.1 General

Here, at least two cuts (default) shall be used, an optional third cut can be used. The alignment of the cuts must be along the symmetry planes of the antenna array. No alignment is required for spurious emissions.

When alignment is required:

- 1) The first mandatory cut is a horizontal cut passing through the peak direction of the main beam.
- 2) The second mandatory is a vertical cut passing through the peak direction of the main beam. Using the data from these two mandatory cuts, a conditional pattern multiplication can be used.
- 3) The third optional cut is a vertical cut orthogonal to the first and the second cut.

When alignment is not required, the cuts can be aligned arbitrarily.

Once the number and the orientation of the cuts are decided, the total EIRP is measured on the orthogonal cuts and the TRP is then calculated as follows: First the contributions from each cut is calculated as

$$EIRP_{av,cut-n} = \frac{1}{P} \sum_{j=1}^P EIRP(j)$$

where  $P$  is the number of sampling points in the cut. The final contribution for all cuts is calculated as

$$TRP_{Estimate} = \frac{1}{N} \sum_{n=1}^N EIRP_{av,cut-n}$$

where  $N$  is the number of cuts. Note that when orthogonal cuts are measured, the interclause points are measured multiple times and the repeated values can be removed from the samples before averaging.

When two cuts measurements are used, a conditional pattern multiplication can be applied. The following are the conditions for applying pattern multiplication:

- i. The vertical cut (and the main beam) is in the  $xz$  -plane
- ii. The frequency of the emission is within the downlink operating band.
- iii. The bandwidth of the emission is the same as the bandwidth of the in-band modulated signal

- iv. The emission appears/disappears when the Tx power is turned on/off.
- v. The antenna arrays of the EUT
  - 1) Have rectangular grids of antenna element positions
  - 2) Have symmetry planes that are vertical and horizontal.
  - 3) Have parallel antenna planes

The antenna array is here assumed to be placed in the  $yz$ -plane. The pattern multiplication is performed in  $uv$ -coordinates and the data in the two cuts are denoted  $\text{EIRP}_{\text{cut1}}(\phi)$  at  $\theta = \theta_H$  and a vertical cut with data  $\text{EIRP}_{\text{cut2}}(\theta)$  at  $\phi = 0$ . The data is split in two parts corresponding to the forward and backward hemispheres. The  $uv$ -coordinates are the projections of the angular directions onto the antenna plane, here the  $yz$ -plane. Using the spherical coordinates as depicted in figure I.2.2-1 the  $u$  and  $v$  coordinates are defined as:

$$\begin{cases} u = \sin \theta \sin \phi \\ v = \cos \theta \end{cases}$$

Note that only the data on the cuts are measured.

Calculate power density/EIRP values outside the two cardinal cuts as

$$\text{EIRP}(u, v) = \frac{\text{EIRP}_{\text{cut1}}(u)\text{EIRP}_{\text{cut2}}(v)}{\text{EIRP}(0, \nu_H)}$$

The pattern multiplication is applied separately for the forward (fwd) and backward (bwd) hemisphere. The TRP is then calculated as

$$\text{TRP} = \frac{1}{4\pi} \left[ \iint_{\text{fwd}} \text{EIRP}_{\text{fwd}}(u, v) \frac{dudv}{\sqrt{1-u^2-v^2}} + \iint_{\text{bwd}} \text{EIRP}_{\text{bwd}}(u, v) \frac{dudv}{\sqrt{1-u^2-v^2}} \right]$$

NOTE: The numerical singularity at  $u^2 + v^2 = 1$  must be treated with care, e.g. by change of variables.

## 1.5.2 Operating band unwanted emissions

The procedure is as follows:

- 1) Follow steps described in annex I.5.1 for the first two mandatory cuts and calculate the  $\text{TRP}_{\text{Estimate}}$ .
- 2) Compare the  $\text{TRP}_{\text{Estimate}}$  to the limit.
- 3) If the  $\text{TRP}_{\text{Estimate}}$  is above the limit, perform the measurement on an additional third cut and repeat steps 1 to 2.

## 1.5.3 Spurious unwanted emissions

The procedure is as follows:

- 1) Follow steps described in annex I.5.1 for two cuts and calculate the preliminary  $\text{TRP}_{\text{Estimate}}$ .
- 2) Add the appropriate correction factor  $\Delta\text{TRP}$  according to table I.5.3-1 to ensure overestimation with 95% confidence.
- 3) Compare the corrected  $\text{TRP}_{\text{Estimate}}$  (including  $\Delta\text{TRP}$ ) to the limit.
- 4) If the corrected  $\text{TRP}_{\text{Estimate}}$  is above the limit, perform the measurement on an additional third cut and repeat steps 1 to 3.

**Table I.5.3-1: The correction factor for two or three cuts dense sampling**

	Three cuts	Two cuts
Correction factor $\Delta\text{TRP}$ (dB)	2.0	2.5

## 1.6 Wave vector space grid

If EUT is mounted along the yz plane as shown in figure I.2.2-1, the reference step in wave vector space can be determined by

$$\Delta u_{\text{ref}} = \frac{\lambda}{D_y}$$

$$\Delta v_{\text{ref}} = \frac{\lambda}{D_z}$$

where  $D_y$  is the length of radiating parts of EUT along y-axis,  $D_z$  is the length of radiating parts of EUT along the z-axis.

According to the relationship between the normalized wave vector and spherical coordinate, the wave vector can be represented as following:

$$u = \sin(\theta) \sin(\phi), v = \cos(\theta)$$

The total radiated power (TRP) in the wave vector space is determined by:

$$\text{TRP}_{\text{estimate}} = \frac{\Delta u_{\text{ref}} \Delta v_{\text{ref}}}{4\pi} \left( \sum_{\substack{u^2+v^2 < 1 \\ \cos\phi > 0}} \frac{\text{EIRP}(\theta_n, \phi_{m,n})}{\sin\theta_n |\cos\phi_{m,n}|} + \sum_{\substack{u^2+v^2 < 1 \\ \cos\phi < 0}} \frac{\text{EIRP}(\theta_n, \phi_{m,n})}{\sin\theta_n |\cos\phi_{m,n}|} \right)$$

For spurious Tx or Rx emissions and where due to practical reasons such as time constraints or turn-table precision, measurement with the reference steps is not practical, sparser grids can be used. Use of sparse grids can lead to errors in TRP assessment. In order to characterize these errors, the SF (sparsity factor) of the grid is defined as

$$SF = \max\left(\frac{\Delta u_{\text{grid}}}{\Delta u_{\text{ref}}}, \frac{\Delta v_{\text{grid}}}{\Delta v_{\text{ref}}}\right)$$

Where  $\Delta u_{\text{grid}}$  and  $\Delta v_{\text{grid}}$  are the actual steps used in the wave vector space in the measurement and the upper bound of their value is 1/12, corresponding to 15 degree steps close to boresight.

## 1.7 Void

## 1.8 Void

## 1.9 Full sphere with sparse sampling

The procedure is as follows:

- 1) Set the angular grid:
  - a. Non-harmonic frequencies: choose the angular steps  $\Delta\phi$  and  $\Delta\theta$  smaller than or equal to 15 degrees. Calculate the sparsity factor (SF) as

$$SF = \max\left(\frac{\Delta\phi}{\Delta\phi_{\text{ref}}}, \frac{\Delta\theta}{\Delta\theta_{\text{ref}}}\right)$$

and the correction factor as:

$$\Delta\text{TRP} = \frac{SF-1}{SF_{\text{max}}-1} \cdot 1.0 \text{ dB},$$

where  $SF_{\text{max}}$  corresponds to 15 degrees angular step. If the sparsity factor is smaller than 1, the correction factor  $\Delta\text{TRP}$  is 0 dB.

Harmonic frequencies with fixed beam test signal: choose the angular steps smaller than or equal to the reference angular steps  $\Delta\phi_{\text{ref}}$  and  $\Delta\theta_{\text{ref}}$ . Correction factor  $\Delta\text{TRP}$  is 0 dB.

Harmonic frequencies with beam sweeping test signal: set the angular steps to 15 degrees. Correction factor is  $\Delta\text{TRP}$  0 dB.

- 2) Apply a suitable numerical integration to calculate the preliminary  $\text{TRP}_{\text{Estimate}}$ .
- 3) Add the appropriate correction factor  $\Delta\text{TRP}$  according to step 1 to ensure an overestimation with 95 % confidence.
- 4) Compare the corrected  $\text{TRP}_{\text{Estimate}}$  (including  $\Delta\text{TRP}$ ) with the limit. If the corrected  $\text{TRP}_{\text{Estimate}}$  is above the limit, choose a smaller angular step and repeat steps 2-4. If the sparsity factor is less than one, no significant improvement of accuracy is expected.

## I.10 Beam-based directions

Beam-based direction can be used in the base station *operating band* only if the directivity of the radiation pattern of the emissions being measured is known.  $\text{TRP}_{\text{Estimate}}$  is defined as

$$\text{TRP}_{\text{Estimate}} = \frac{\text{EIRP}_{\text{peak}}}{D_{\text{EUT}}}, \text{ where } \text{EIRP}_{\text{peak}} \text{ is the maximum EIRP in the beam peak direction within a particular beam direction pair and } D_{\text{EUT}} \text{ is the directivity of the EUT.}$$

## I.11 Peak method

The peak method can be used when frequencies with unwanted peak emissions are identified during pre-scan. The method does not provide an estimate of TRP.

For each peak emission frequency identified during pre-scan, measure peak EIRP or power density as follows:

- 1) Move EUT and test antenna to the same position where the peak emission is recorded during the pre-scan.
- 2) Move the EUT around the position and test antenna orientation to find the final peak EIRP or power density.
- 3) The measured peak power density or EIRP shall be used to demonstrate conformance.

NOTE: Peak EIRP is the linear sum of two orthogonal polarized components.

## I.12 Equal sector with peak average

Equal sector with peak average can be performed on frequencies with unwanted peak emission, which are considered by the peak method for further measurements.

The spherical angle  $\phi$  is divided into K equal sectors. If the largest dimension of EUT is less than 60 cm, then each sector is a half quadrant of 45°.

For each peak emission frequency, measure peak EIRP of beams belonging to different sectors of the sphere as follows:

- 1) Move EUT and test antenna to the same position where the emission peak is recorded during the pre-scan.
- 2) Move EUT around the position and test antenna orientation to find the final peak EIRP.
- 3) Repeat Steps 1 to 2 until all sectors are covered.
- 4) Calculate  $\text{TRP}_{\text{Estimate}}$  as

$$\text{TRP}_{\text{Estimate}} = \frac{1}{K} \sum_{k=1}^K \text{EIRP}_k, \text{ where } \text{EIRP}_k \text{ is the peak EIRP in the } k\text{th sector.}$$

NOTE: Peak EIRP is the linear sum of two orthogonal polarized components.

---

## I.13 Pre-scan

Pre-scan is used to identify frequencies with unwanted emission power levels above a certain threshold. The pre-scan does not provide an estimate of TRP. An emission frequency identified by a pre-scan may be further investigated by any of the TRP measurement methods in this annex.

The procedure for pre-scan is as follows:

- 1) Scan the entire surface around EUT.
- 2) Rotate test antenna to cover all possible polarizations of emissions to detect maximum emissions.
- 3) Record the list of frequencies and corresponding unwanted emission power levels, EUT spatial positions, and test antenna polarization for which the maximum emission levels occur.
- 4) Emissions which 20 dB or more below the specified limit shall not require further measurements.

---

# Annex J (normative): Propagation conditions

## J.1 Static propagation condition

The propagation for the static performance measurement is an Additive White Gaussian Noise (AWGN) environment. No fading or multi-paths exist for this propagation model.

---

## J.2 Multi-path fading propagation conditions

The multipath propagation conditions consist of several parts:

- A delay profile in the form of a "tapped delay-line", characterized by a number of taps at fixed positions on a sampling grid. The profile can be further characterized by the r.m.s. delay spread and the maximum delay spanned by the taps.
- A combination of channel model parameters that include the Delay profile and the Doppler spectrum that is characterized by a classical spectrum shape and a maximum Doppler frequency.
- Different models are used for FR1 (410 MHz - 7.125 GHz), FR2-1 (24.25 – 52.6 GHz) and FR2-2 (52.6 – 71 GHz).

Initial channel matrix for LOS component of TDL-D channel model is equal to channel matrix of Static propagation conditions in Clause B.1 in TS 38.101-4.

### J.2.1 Delay profiles

The delay profiles are simplified from the TR 38.901 [23] TDL models. The simplification steps are shown below for information. These steps are only used when new delay profiles are created. Otherwise, the delay profiles specified in annex J.2.1.1 and J.2.1.2 can be used as such.

Step 1: Use the original TDL model from TR 38.901 [23].

Step 2: Re-order the taps in ascending delays.

Step 3: Perform delay scaling according to the procedure described in clause 7.7.3 in TR 38.901 [23].

Step 4: Apply the quantization to the delay resolution 5 ns. This is done simply by rounding the tap delays to the nearest multiple of the delay resolution.

Step 5: If multiple taps are rounded to the same delay bin, merge them by calculating their linear power sum.

Step 6: If there are more than 12 taps in the quantized model, merge the taps as follows

- Find the weakest tap from all taps (both merged and unmerged taps are considered)
  - If there are two or more taps having the same value and are the weakest, select the tap with the smallest delay as the weakest tap.
- When the weakest tap is the first delay tap, merge taps as follows
  - Update the power of the first delay tap as the linear power sum of the weakest tap and the second delay tap.
  - Remove the second delay tap.
- When the weakest tap is the last delay tap, merge taps as follows
  - Update the power of the last delay tap as the linear power sum of the second-to-last tap and the last tap.

- Remove the second-to-last tap.
- Otherwise
  - For each side of the weakest tap, identify the neighbour tap that has the smaller delay difference to the weakest tap.
    - When the delay difference between the weakest tap and the identified neighbour tap on one side equals the delay difference between the weakest tap and the identified neighbour tap on the other side.
      - Select the neighbour tap that is weaker in power for merging.
    - Otherwise, select the neighbour tap that has smaller delay difference for merging.
  - To merge, the power of the merged tap is the linear sum of the power of the weakest tap and the selected tap.
  - When the selected tap is the first tap, the location of the merged tap is the location of the first tap. The weakest tap is removed.
  - When the selected tap is the last tap, the location of the merged tap is the location of the last tap. The weakest tap is removed.
  - Otherwise, the location of the merged tap is based on the average delay of the weakest tap and selected tap. If the average delay is on the sampling grid, the location of the merged tap is the average delay. Otherwise, the location of the merged tap is rounded towards the direction of the selected tap (e.g. 10 ns & 20 ns → 15 ns, 10 ns & 25 ns → 20 ns, if 25 ns had higher or equal power; 15 ns, if 10 ns had higher power). The weakest tap and the selected tap are removed.
- Repeat step 6 until the final number of taps is 12.

Step 7: Round the amplitudes of taps to one decimal (e.g. -8.78 dB → -8.8 dB)

Step 8: If the delay spread has slightly changed due to the tap merge, adjust the final delay spread by increasing or decreasing the power of the last tap so that the delay spread is corrected.

Step 9: Re-normalize the highest tap to 0 dB.

NOTE 1: Some values of the delay profile created by the simplification steps may differ from the values in tables J.2.1.1-2, J.2.1.1-3, J.2.1.1-4, and J.2.1.2-2 for the corresponding model.

NOTE 2: For Step 5 and Step 6, the power values are expressed in the linear domain using 6 digits of precision. The operations are in the linear domain.

NOTE 3: Delay profile for TDLD30 is generated under assumption that Steps 1-8 are applied for taps with Rayleigh distribution.

## J.2.1.1 Delay profiles for FR1

The delay profiles for FR1 are selected to be representative of low, medium and high delay spread environment. The resulting model parameters are specified in J.2.1.1-1 and the tapped delay line models are specified in tables J.2.1.1-2 ~ J.2.1.1-4.

**Table J.2.1.1-1: Delay profiles for NR channel models**

Model	Number of channel taps	Delay spread (r.m.s.)	Maximum excess tap delay (span)	Delay resolution
TDLA30	12	30 ns	290 ns	5 ns
TDLB100	12	100 ns	480 ns	5 ns
TDLC300	12	300 ns	2595 ns	5 ns

**Table J.2.1.1-2 TDLA30 (DS = 30 ns)**

Tap #	Delay (ns)	Power (dB)	Fading distribution
1	0	-15.5	Rayleigh
2	10	0	
3	15	-5.1	
4	20	-5.1	
5	25	-9.6	
6	50	-8.2	
7	65	-13.1	
8	75	-11.5	
9	105	-11.0	
10	135	-16.2	
11	150	-16.6	
12	290	-26.2	

**Table J.2.1.1-3 TDLB100 (DS = 100ns)**

Tap #	Delay (ns)	Power (dB)	Fading distribution
1	0	0	Rayleigh
2	10	-2.2	
3	20	-0.6	
4	30	-0.6	
5	35	-0.3	
6	45	-1.2	
7	55	-5.9	
8	120	-2.2	
9	170	-0.8	
10	245	-6.3	
11	330	-7.5	
12	480	-7.1	

**Table J.2.1.1-4 TDLC300 (DS = 300 ns)**

Tap #	Delay (ns)	Power (dB)	Fading distribution
1	0	-6.9	Rayleigh
2	65	0	
3	70	-7.7	
4	190	-2.5	
5	195	-2.4	
6	200	-9.9	
7	240	-8.0	
8	325	-6.6	
9	520	-7.1	
10	1045	-13.0	
11	1510	-14.2	
12	2595	-16.0	

## J.2.1.2 Delay profiles for FR2

The delay profiles for FR2 are specified in J.2.1.2-1 and the tapped delay line models are specified in table J.2.1.2-2.

**Table J.2.1.2-1: Delay profiles for NR channel models**

Model	Number of channel taps	Delay spread (r.m.s.)	Maximum excess tap delay (span)	Delay resolution
TDLA30	12	30 ns	290 ns	5 ns
TDLD30	10	30 ns	375 ns	5 ns



**Table J.2.1.2-2: TDLA30 (DS = 30 ns)**

Tap #	Delay [ns]	Power [dB]	Fading distribution
1	0	-15.5	Rayleigh
2	10	0	
3	15	-5.1	
4	20	-5.1	
5	25	-9.6	
6	50	-8.2	
7	65	-13.1	
8	75	-11.5	
9	105	-11.0	
10	135	-16.2	
11	150	-16.6	
12	290	-26.2	

**Table J.2.1.2-3 TDL30 (DS = 30 ns)**

Tap #	Delay [ns]	Power [dB]	Fading distribution
1	0	-0.2	LOS path
	0	-12.4	Rayleigh
2	20	-21	Rayleigh
3	40	-16.7	Rayleigh
4	55	-18.3	Rayleigh
5	80	-21.9	Rayleigh
6	120	-27.8	Rayleigh
7	240	-23.6	Rayleigh
8	285	-24.8	Rayleigh
9	290	-30.0	Rayleigh
10	375	-27.6	Rayleigh

Note 1: Tap #1 follows a Rician distribution.

## J.2.2 Combinations of channel model parameters

The propagation conditions used for the performance measurements in multi-path fading environment are indicated as a combination of a channel model name and a maximum Doppler frequency, i.e., TDLA<DS>-<Doppler>, TDLB<DS>-<Doppler> or TDLC<DS>-<Doppler> where '<DS>' indicates the desired delay spread and '<Doppler>' indicates the maximum Doppler frequency (Hz).

Table J.2.2-1 and J.2.2-2 show the propagation conditions that are used for the performance measurements in multi-path fading environment for low, medium and high Doppler frequencies for FR1 and FR2, respectively.

**Table J.2.2-1: Channel model parameters for FR1**

Combination name	Model	Maximum Doppler frequency
TDLA30-5	TDLA30	5 Hz
TDLA30-10	TDLA30	10 Hz
TDLB100-400	TDLB100	400 Hz
TDLC300-100	TDLC300	100 Hz
TDLC300-600	TDLC300	600 Hz
TDLC300-1200	TDLC300	1200 Hz

**Table J.2.2-2: Channel model parameters for FR2**

Combination name	Model	Maximum Doppler frequency
TDLA30-75	TDLA30	75 Hz
TDLA30-300	TDLA30	300 Hz
TDLA10-650	TDLA10	650 Hz
TDLA30-650	TDLA30	650 Hz
TDLD10-200	TDLD10	200 Hz
TDLD30-200	TDLD30	200 Hz
TDLD30-35	TDLD30	35 Hz

## J.2.3 MIMO channel correlation matrices

The MIMO channel correlation matrices defined in J.2.3 apply for the antenna configuration using uniform linear arrays at both gNB and UE and for the antenna configuration using cross polarized antennas.

### J.2.3.1 MIMO correlation matrices using Uniform Linear Array

The MIMO channel correlation matrices defined in J.2.3.1 apply for the antenna configuration using uniform linear array (ULA) at both gNB and UE.

#### J.2.3.1.1 Definition of MIMO correlation matrices

Table J.2.3.1.1-1 defines the correlation matrix for the gNB.

**Table J.2.3.1.1-1: gNB correlation matrix**

	gNB correlation
One antenna	$R_{gNB} = 1$
Two antennas	$R_{gNB} = \begin{pmatrix} 1 & \alpha \\ \alpha^* & 1 \end{pmatrix}$
Four antennas	$R_{gNB} = \begin{pmatrix} 1 & \alpha^{1/9} & \alpha^{4/9} & \alpha \\ \alpha^{1/9*} & 1 & \alpha^{1/9} & \alpha^{4/9} \\ \alpha^{4/9*} & \alpha^{1/9*} & 1 & \alpha^{1/9} \\ \alpha^* & \alpha^{4/9*} & \alpha^{1/9*} & 1 \end{pmatrix}$
Eight antennas	$R_{gNB} = \begin{pmatrix} 1 & \alpha^{1/49} & \alpha^{4/49} & \alpha^{9/49} & \alpha^{16/49} & \alpha^{25/49} & \alpha^{36/49} & \alpha \\ \alpha^{1/49*} & 1 & \alpha^{1/49} & \alpha^{4/49} & \alpha^{9/49} & \alpha^{16/49} & \alpha^{25/49} & \alpha^{36/49} \\ \alpha^{4/49*} & \alpha^{1/49*} & 1 & \alpha^{1/49} & \alpha^{4/49} & \alpha^{9/49} & \alpha^{16/49} & \alpha^{25/49} \\ \alpha^{9/49*} & \alpha^{4/49*} & \alpha^{1/49*} & 1 & \alpha^{1/49} & \alpha^{4/49} & \alpha^{9/49} & \alpha^{16/49} \\ \alpha^{16/49*} & \alpha^{9/49*} & \alpha^{4/49*} & \alpha^{1/49*} & 1 & \alpha^{1/49} & \alpha^{4/49} & \alpha^{9/49} \\ \alpha^{25/49*} & \alpha^{16/49*} & \alpha^{9/49*} & \alpha^{4/49*} & \alpha^{1/49*} & 1 & \alpha^{1/49} & \alpha^{4/49} \\ \alpha^{36/49*} & \alpha^{25/49*} & \alpha^{16/49*} & \alpha^{9/49*} & \alpha^{4/49*} & \alpha^{1/49*} & 1 & \alpha^{1/49} \\ \alpha^* & \alpha^{36/49*} & \alpha^{25/49*} & \alpha^{16/49*} & \alpha^{9/49*} & \alpha^{4/49*} & \alpha^{1/49*} & 1 \end{pmatrix}$

Table J.2.3.1.1-2 defines the correlation matrix for the UE:

**Table J.2.3.1.1-2: UE correlation matrix**

	One antenna	Two antennas	Four antennas
UE correlation	$R_{UE} = 1$	$R_{UE} = \begin{pmatrix} 1 & \beta \\ \beta^* & 1 \end{pmatrix}$	$R_{UE} = \begin{pmatrix} 1 & \beta^{1/9} & \beta^{4/9} & \beta \\ \beta^{1/9*} & 1 & \beta^{1/9} & \beta^{4/9} \\ \beta^{4/9*} & \beta^{1/9*} & 1 & \beta^{1/9} \\ \beta^* & \beta^{4/9*} & \beta^{1/9*} & 1 \end{pmatrix}$

Table J.2.3.1.1-3 defines the channel spatial correlation matrix  $R_{spat}$ . The parameters,  $\alpha$  and  $\beta$  in table J.2.3.1.1-3 defines the spatial correlation between the antennas at the gNB and UE respectively.

**Table J.2.3.1.1-3:  $R_{spat}$  correlation matrices**

1x2 case	$R_{spat} = R_{gNB} = \begin{bmatrix} 1 & \alpha \\ \alpha^* & 1 \end{bmatrix}$
1x4 case	$R_{spat} = R_{gNB} = \begin{pmatrix} 1 & \alpha^{1/9} & \alpha^{4/9} & \alpha \\ \alpha^{1/9*} & 1 & \alpha^{1/9} & \alpha^{4/9} \\ \alpha^{4/9*} & \alpha^{1/9*} & 1 & \alpha^{1/9} \\ \alpha^* & \alpha^{4/9*} & \alpha^{1/9*} & 1 \end{pmatrix}$
2x2 case	$R_{spat} = R_{UE} \otimes R_{gNB} = \begin{pmatrix} 1 & \beta \\ \beta^* & 1 \end{pmatrix} \otimes \begin{pmatrix} 1 & \alpha \\ \alpha^* & 1 \end{pmatrix} = \begin{pmatrix} 1 & \alpha & \beta & \beta\alpha \\ \alpha^* & 1 & \beta\alpha^* & \beta \\ \beta^* & \beta^*\alpha & 1 & \alpha \\ \beta^*\alpha^* & \beta^*\alpha^* & \alpha^* & 1 \end{pmatrix}$
2x4 case	$R_{spat} = R_{UE} \otimes R_{gNB} = \begin{pmatrix} 1 & \beta \\ \beta^* & 1 \end{pmatrix} \otimes \begin{pmatrix} 1 & \alpha^{1/9} & \alpha^{4/9} & \alpha \\ \alpha^{1/9*} & 1 & \alpha^{1/9} & \alpha^{4/9} \\ \alpha^{4/9*} & \alpha^{1/9*} & 1 & \alpha^{1/9} \\ \alpha^* & \alpha^{4/9*} & \alpha^{1/9*} & 1 \end{pmatrix}$
4x4 case	$R_{spat} = R_{UE} \otimes R_{gNB} = \begin{pmatrix} 1 & \beta^{1/9} & \beta^{4/9} & \beta \\ \beta^{1/9*} & 1 & \beta^{1/9} & \beta^{4/9} \\ \beta^{4/9*} & \beta^{1/9*} & 1 & \beta^{1/9} \\ \beta^* & \beta^{4/9*} & \beta^{1/9*} & 1 \end{pmatrix} \otimes \begin{pmatrix} 1 & \alpha^{1/9} & \alpha^{4/9} & \alpha \\ \alpha^{1/9*} & 1 & \alpha^{1/9} & \alpha^{4/9} \\ \alpha^{4/9*} & \alpha^{1/9*} & 1 & \alpha^{1/9} \\ \alpha^* & \alpha^{4/9*} & \alpha^{1/9*} & 1 \end{pmatrix}$

For cases with more antennas at either gNB or UE or both, the channel spatial correlation matrix can still be expressed as the Kronecker product of  $R_{UE}$  and  $R_{gNB}$  according to  $R_{spat} = R_{UE} \otimes R_{gNB}$ .

### J.2.3.1.2 MIMO correlation matrices at high, medium and low level

The  $\alpha$  and  $\beta$  for different correlation types are given in table J.2.3.1.2-1.

**Table J.2.3.1.2-1: Correlation for high, medium and low level**

Low correlation		Medium correlation		High correlation	
$\alpha$	$\beta$	$\alpha$	$\beta$	$\alpha$	$\beta$
0	0	0.9	0.3	0.9	0.9

The correlation matrices for high, medium and low correlation are defined in table J.2.3.1.2-2, J.2.3.1.2-3 and J.2.3.1.2-4 as below.

The values in table J.2.3.1.2-2 have been adjusted for the 2x4 and 4x4 high correlation cases to insure the correlation matrix is positive semi-definite after round-off to 4 digit precision. This is done using the equation:

$$R_{high} = [R_{spatial} + aI_n] / (1 + a)$$

Where the value "a" is a scaling factor such that the smallest value is used to obtain a positive semi-definite result. For the 2x4 high correlation case, a=0.00010. For the 4x4 high correlation case, a=0.00012.

The same method is used to adjust the 4x4 medium correlation matrix in table J.2.3.1.2-3 to insure the correlation matrix is positive semi-definite after round-off to 4 digit precision with a =0.00012.

**Table J.2.3.1.2-2: MIMO correlation matrices for high correlation**

1x2 case	$R_{high} = \begin{pmatrix} 1 & 0.9 \\ 0.9 & 1 \end{pmatrix}$
2x2 case	$R_{high} = \begin{pmatrix} 1 & 0.9 & 0.9 & 0.81 \\ 0.9 & 1 & 0.81 & 0.9 \\ 0.9 & 0.81 & 1 & 0.9 \\ 0.81 & 0.9 & 0.9 & 1 \end{pmatrix}$
2x4 case	$R_{high} = \begin{bmatrix} 1.0000 & 0.9883 & 0.9542 & 0.8999 & 0.8999 & 0.8894 & 0.8587 & 0.8099 \\ 0.9883 & 1.0000 & 0.9883 & 0.9542 & 0.8894 & 0.8999 & 0.8894 & 0.8587 \\ 0.9542 & 0.9883 & 1.0000 & 0.9883 & 0.8587 & 0.8894 & 0.8999 & 0.8894 \\ 0.8999 & 0.9542 & 0.9883 & 1.0000 & 0.8099 & 0.8587 & 0.8894 & 0.8999 \\ 0.8999 & 0.8894 & 0.8587 & 0.8099 & 1.0000 & 0.9883 & 0.9542 & 0.8999 \\ 0.8894 & 0.8999 & 0.8894 & 0.8587 & 0.9883 & 1.0000 & 0.9883 & 0.9542 \\ 0.8587 & 0.8894 & 0.8999 & 0.8894 & 0.9542 & 0.9883 & 1.0000 & 0.9883 \\ 0.8099 & 0.8587 & 0.8894 & 0.8999 & 0.8999 & 0.9542 & 0.9883 & 1.0000 \end{bmatrix}$
4x4 case	$R_{high} = \begin{bmatrix} 1.0000 & 0.9882 & 0.9541 & 0.8999 & 0.9882 & 0.9767 & 0.9430 & 0.8894 & 0.9541 & 0.9430 & 0.9105 & 0.8587 & 0.8999 & 0.8894 & 0.8587 & 0.8099 \\ 0.9882 & 1.0000 & 0.9882 & 0.9541 & 0.9767 & 0.9882 & 0.9767 & 0.9430 & 0.9430 & 0.9541 & 0.9430 & 0.9105 & 0.8894 & 0.8999 & 0.8894 & 0.8587 \\ 0.9541 & 0.9882 & 1.0000 & 0.9882 & 0.9430 & 0.9767 & 0.9882 & 0.9767 & 0.9105 & 0.9430 & 0.9541 & 0.9430 & 0.8587 & 0.8894 & 0.8999 & 0.8894 \\ 0.8999 & 0.9541 & 0.9882 & 1.0000 & 0.8894 & 0.9430 & 0.9767 & 0.9882 & 0.8587 & 0.9105 & 0.9430 & 0.9541 & 0.8099 & 0.8587 & 0.8894 & 0.8999 \\ 0.9882 & 0.9767 & 0.9430 & 0.8894 & 1.0000 & 0.9882 & 0.9541 & 0.8999 & 0.9882 & 0.9767 & 0.9430 & 0.8894 & 0.9541 & 0.9430 & 0.9105 & 0.8587 \\ 0.9767 & 0.9882 & 0.9767 & 0.9430 & 0.8894 & 1.0000 & 0.9882 & 0.9541 & 0.9767 & 0.9882 & 0.9767 & 0.9430 & 0.9430 & 0.9541 & 0.9430 & 0.9105 \\ 0.9430 & 0.9767 & 0.9882 & 0.9767 & 0.9541 & 0.9882 & 1.0000 & 0.9882 & 0.9430 & 0.9767 & 0.9882 & 0.9767 & 0.9105 & 0.9430 & 0.9541 & 0.9430 \\ 0.8894 & 0.9430 & 0.9767 & 0.9882 & 0.8999 & 0.9541 & 0.9882 & 1.0000 & 0.8894 & 0.9430 & 0.9767 & 0.9882 & 0.8587 & 0.9105 & 0.9430 & 0.9541 \\ 0.9541 & 0.9430 & 0.9105 & 0.8587 & 0.9882 & 0.9767 & 0.9430 & 0.8894 & 1.0000 & 0.9882 & 0.9541 & 0.8999 & 0.9882 & 0.9767 & 0.9430 & 0.8894 \\ 0.9430 & 0.9541 & 0.9430 & 0.9105 & 0.9767 & 0.9882 & 0.9767 & 0.9430 & 0.9882 & 1.0000 & 0.9882 & 0.9541 & 0.9767 & 0.9882 & 0.9767 & 0.9430 \\ 0.9105 & 0.9430 & 0.9541 & 0.9430 & 0.9430 & 0.9767 & 0.9882 & 0.9767 & 0.9541 & 0.9882 & 1.0000 & 0.9882 & 0.9430 & 0.9767 & 0.9882 & 0.9767 \\ 0.8587 & 0.9105 & 0.9430 & 0.9541 & 0.8894 & 0.9430 & 0.9767 & 0.9882 & 0.8999 & 0.9541 & 0.9882 & 1.0000 & 0.8894 & 0.9430 & 0.9767 & 0.9882 \\ 0.8999 & 0.8894 & 0.8587 & 0.8099 & 0.9541 & 0.9430 & 0.9105 & 0.8587 & 0.9882 & 0.9767 & 0.9430 & 0.8894 & 1.0000 & 0.9882 & 0.9541 & 0.8999 \\ 0.8894 & 0.8999 & 0.8894 & 0.8587 & 0.9430 & 0.9541 & 0.9430 & 0.9105 & 0.9767 & 0.9882 & 0.9767 & 0.9430 & 0.9882 & 1.0000 & 0.9882 & 0.9541 \\ 0.8587 & 0.8894 & 0.8999 & 0.8894 & 0.9105 & 0.9430 & 0.9541 & 0.9430 & 0.9430 & 0.9767 & 0.9882 & 0.9767 & 0.9541 & 0.9882 & 1.0000 & 0.9882 \\ 0.8099 & 0.8587 & 0.8894 & 0.8999 & 0.8587 & 0.9105 & 0.9430 & 0.9541 & 0.8894 & 0.9430 & 0.9767 & 0.9882 & 0.8999 & 0.9541 & 0.9882 & 1.0000 \end{bmatrix}$

**Table J.2.3.1.2-3: MIMO correlation matrices for medium correlation**

1x2 case	N/A
2x2 case	$R_{medium} = \begin{pmatrix} 1.0000 & 0.9000 & 0.3000 & 0.2700 \\ 0.9000 & 1.0000 & 0.2700 & 0.3000 \\ 0.3000 & 0.2700 & 1.0000 & 0.9000 \\ 0.2700 & 0.3000 & 0.9000 & 1.0000 \end{pmatrix}$
2x4 case	$R_{medium} = \begin{pmatrix} 1.0000 & 0.9884 & 0.9543 & 0.9000 & 0.3000 & 0.2965 & 0.2863 & 0.2700 \\ 0.9884 & 1.0000 & 0.9884 & 0.9543 & 0.2965 & 0.3000 & 0.2965 & 0.2863 \\ 0.9543 & 0.9884 & 1.0000 & 0.9884 & 0.2863 & 0.2965 & 0.3000 & 0.2965 \\ 0.9000 & 0.9543 & 0.9884 & 1.0000 & 0.2700 & 0.2863 & 0.2965 & 0.3000 \\ 0.3000 & 0.2965 & 0.2863 & 0.2700 & 1.0000 & 0.9884 & 0.9543 & 0.9000 \\ 0.2965 & 0.3000 & 0.2965 & 0.2863 & 0.9884 & 1.0000 & 0.9884 & 0.9543 \\ 0.2863 & 0.2965 & 0.3000 & 0.2965 & 0.9543 & 0.9884 & 1.0000 & 0.9884 \\ 0.2700 & 0.2863 & 0.2965 & 0.3000 & 0.9000 & 0.9543 & 0.9884 & 1.0000 \end{pmatrix}$
4x4 case	$R_{medium} = \begin{pmatrix} 1.0000 & 0.9882 & 0.9541 & 0.8999 & 0.8747 & 0.8645 & 0.8347 & 0.7872 & 0.5855 & 0.5787 & 0.5588 & 0.5270 & 0.3000 & 0.2965 & 0.2862 & 0.2700 \\ 0.9882 & 1.0000 & 0.9882 & 0.9541 & 0.8645 & 0.8747 & 0.8645 & 0.8347 & 0.5787 & 0.5855 & 0.5787 & 0.5588 & 0.2965 & 0.3000 & 0.2965 & 0.2862 \\ 0.9541 & 0.9882 & 1.0000 & 0.9882 & 0.8347 & 0.8645 & 0.8747 & 0.8645 & 0.5588 & 0.5787 & 0.5855 & 0.5787 & 0.2862 & 0.2965 & 0.3000 & 0.2965 \\ 0.8999 & 0.9541 & 0.9882 & 1.0000 & 0.7872 & 0.8347 & 0.8645 & 0.8747 & 0.5270 & 0.5588 & 0.5787 & 0.5855 & 0.2700 & 0.2862 & 0.2965 & 0.3000 \\ 0.8747 & 0.8645 & 0.8347 & 0.7872 & 1.0000 & 0.9882 & 0.9541 & 0.8999 & 0.8747 & 0.8645 & 0.8347 & 0.7872 & 0.5855 & 0.5787 & 0.5588 & 0.5270 \\ 0.8645 & 0.8747 & 0.8645 & 0.8347 & 0.9882 & 1.0000 & 0.9882 & 0.9541 & 0.8645 & 0.8747 & 0.8645 & 0.8347 & 0.5787 & 0.5855 & 0.5787 & 0.5588 \\ 0.8347 & 0.8645 & 0.8747 & 0.8645 & 0.9541 & 0.9882 & 1.0000 & 0.9882 & 0.8347 & 0.8645 & 0.8747 & 0.8645 & 0.5588 & 0.5787 & 0.5855 & 0.5787 \\ 0.7872 & 0.8347 & 0.8645 & 0.8747 & 0.8999 & 0.9541 & 0.9882 & 1.0000 & 0.7872 & 0.8347 & 0.8645 & 0.8747 & 0.5270 & 0.5588 & 0.5787 & 0.5855 \\ 0.5855 & 0.5787 & 0.5588 & 0.5270 & 0.8747 & 0.8645 & 0.8347 & 0.7872 & 1.0000 & 0.9882 & 0.9541 & 0.8999 & 0.8747 & 0.8645 & 0.8347 & 0.7872 \\ 0.5787 & 0.5855 & 0.5787 & 0.5588 & 0.8645 & 0.8747 & 0.8645 & 0.8347 & 0.9882 & 1.0000 & 0.9882 & 0.9541 & 0.8645 & 0.8747 & 0.8645 & 0.8347 \\ 0.5588 & 0.5787 & 0.5855 & 0.5787 & 0.8347 & 0.8645 & 0.8747 & 0.8645 & 0.9541 & 0.9882 & 1.0000 & 0.9882 & 0.8347 & 0.8645 & 0.8747 & 0.8645 \\ 0.5270 & 0.5588 & 0.5787 & 0.5855 & 0.7872 & 0.8347 & 0.8645 & 0.8747 & 0.8999 & 0.9541 & 0.9882 & 1.0000 & 0.7872 & 0.8347 & 0.8645 & 0.8747 \\ 0.3000 & 0.2965 & 0.2862 & 0.2700 & 0.5855 & 0.5787 & 0.5588 & 0.5270 & 0.8747 & 0.8645 & 0.8347 & 0.7872 & 1.0000 & 0.9882 & 0.9541 & 0.8999 \\ 0.2965 & 0.3000 & 0.2965 & 0.2862 & 0.5787 & 0.5855 & 0.5787 & 0.5588 & 0.8645 & 0.8747 & 0.8645 & 0.8347 & 0.9882 & 1.0000 & 0.9882 & 0.9541 \\ 0.2862 & 0.2965 & 0.3000 & 0.2965 & 0.5588 & 0.5787 & 0.5855 & 0.5787 & 0.8347 & 0.8645 & 0.8747 & 0.8645 & 0.9541 & 0.9882 & 1.0000 & 0.9882 \\ 0.2700 & 0.2862 & 0.2965 & 0.3000 & 0.5270 & 0.5588 & 0.5787 & 0.5855 & 0.7872 & 0.8347 & 0.8645 & 0.8747 & 0.8999 & 0.9541 & 0.9882 & 1.0000 \end{pmatrix}$

**Table J.2.3.1.2-4: MIMO correlation matrices for low correlation**

1x2 case	$R_{low} = \mathbf{I}_2$
1x4 case	$R_{low} = \mathbf{I}_4$
1x8 case	$R_{low} = \mathbf{I}_8$
2x2 case	$R_{low} = \mathbf{I}_4$
2x4 case	$R_{low} = \mathbf{I}_8$
2x8 case	$R_{low} = \mathbf{I}_{16}$
4x4 case	$R_{low} = \mathbf{I}_{16}$

In table J.2.3.1.2-4,  $\mathbf{I}_d$  is a  $d \times d$  identity matrix.

NOTE: For completeness, the correlation matrices were defined for high, medium and low correlation but performance requirements exist only for low correlation.

### J.2.3.2 Multi-antenna channel models using cross polarized antennas

The MIMO channel correlation matrices defined in J.2.3.2 apply to two cases as presented below:

- One TX antenna and multiple RX antennas case, with cross polarized antennas used at gNB
- Multiple TX antennas and multiple RX antennas case, with cross polarized antennas used at both UE and gNB

The cross-polarized antenna elements with +/-45 degrees polarization slant angles are deployed at gNB. For one TX antenna case, antenna element with +90 degree polarization slant angle is deployed at UE. For multiple TX antennas case, cross-polarized antenna elements with +90/0 degrees polarization slant angles are deployed at UE.

For the cross-polarized antennas, the N antennas are labelled such that antennas for one polarization are listed from 1 to N/2 and antennas for the other polarization are listed from N/2+1 to N, where N is the number of TX or RX antennas.

### J.2.3.2.1 Definition of MIMO correlation matrices using cross polarized antennas

For the channel spatial correlation matrix, the following is used:

$$R_{spat} = P_{UL} (R_{UE} \otimes \Gamma_{UL} \otimes R_{gNB}) P_{UL}^T$$

Where

- $R_{UE}$  is the spatial correlation matrix at the UE with same polarization,
- $R_{gNB}$  is the spatial correlation matrix at the gNB with same polarization,
- $\Gamma_{UL}$  is a polarization correlation matrix,
- $P_{UL}$  is a permutation matrix, and
- $(\bullet)^T$  denotes transpose.

Table J.2.3.2.1-1 defines the polarization correlation matrix.

**Table J.2.3.2.1-1 : Polarization correlation matrix**

	One TX antenna	Multiple TX antennas
Polarization correlation matrix	$\Gamma_{UL} = \begin{bmatrix} 1 & -\gamma \\ -\gamma & 1 \end{bmatrix}$	$\Gamma_{UL} = \begin{bmatrix} 1 & -\gamma & 0 & 0 \\ -\gamma & 1 & 0 & 0 \\ 0 & 0 & 1 & \gamma \\ 0 & 0 & \gamma & 1 \end{bmatrix}$

The matrix  $P_{UL}$  is defined as

$$P_{UL}(a,b) = \begin{cases} 1 & \text{for } a = (j-1)Nr + i \text{ and } b = 2(j-1)Nr + i, & i = 1, \dots, Nr, j = 1, \dots, \lceil Nt/2 \rceil \\ 1 & \text{for } a = (j-1)Nr + i \text{ and } b = 2(j - Nt/2)Nr - Nr + i, & i = 1, \dots, Nr, j = \lceil Nt/2 \rceil + 1, \dots, Nt \\ 0 & \text{otherwise} \end{cases}$$

where  $Nt$  and  $Nr$  is the number of TX and RX antennas respectively, and  $\lceil \bullet \rceil$  is the ceiling operator.

The matrix  $P_{UL}$  is used to map the spatial correlation coefficients in accordance with the antenna element labelling system described in J.2.3.2.

### J.2.3.2.2 Spatial correlation matrices at UE and gNB sides

#### J.2.3.2.2.1 Spatial correlation matrices at UE side

For 1-antenna transmitter,  $R_{UE} = 1$ .

For 2-antenna transmitter using one pair of cross-polarized antenna elements,  $R_{UE} = 1$ .

For 4-antenna transmitter using two pairs of cross-polarized antenna elements,  $R_{UE} = \begin{pmatrix} 1 & \beta \\ \beta^* & 1 \end{pmatrix}$ .

#### J.2.3.2.2.2 Spatial correlation matrices at gNB side

For 2-antenna receiver using one pair of cross-polarized antenna elements,  $R_{gNB} = 1$ .

For 4-antenna receiver using two pairs of cross-polarized antenna elements,  $R_{gNB} = \begin{bmatrix} 1 & \alpha \\ \alpha^* & 1 \end{bmatrix}$ .

For 8-antenna receiver using four pairs of cross-polarized antenna elements,  $R_{gNB} = \begin{pmatrix} 1 & \alpha^{1/9} & \alpha^{4/9} & \alpha \\ \alpha^{1/9*} & 1 & \alpha^{1/9} & \alpha^{4/9} \\ \alpha^{4/9*} & \alpha^{1/9*} & 1 & \alpha^{1/9} \\ \alpha^* & \alpha^{4/9*} & \alpha^{1/9*} & 1 \end{pmatrix}$ .

### J.2.3.2.3 MIMO correlation matrices using cross polarized antennas

The values for parameters  $\alpha$ ,  $\beta$  and  $\gamma$  for low spatial correlation are given in table J.2.3.2.3-1.

**Table J.2.3.2.3-1: Values for parameters  $\alpha$ ,  $\beta$  and  $\gamma$**

Low spatial correlation		
□	□	□
0	0	0
Note 1:	Value of $\alpha$ applies when more than one pair of cross-polarized antenna elements at gNB side.	
Note 2:	Value of $\beta$ applies when more than one pair of cross-polarized antenna elements at UE side.	

The correlation matrices for low spatial correlation are defined in table J.2.3.2.3-2 as below.

**Table J.2.3.2.3-2: MIMO correlation matrices for low spatial correlation**

1x8 case	$R_{low} = \mathbf{I}_8$
2x8 case	$R_{low} = \mathbf{I}_{16}$

In table J.2.3.2.3-2,  $\mathbf{I}_d$  is a  $d \times d$  identity matrix.

## J.3 High speed train condition

The applicable models for high speed train conditions are as follows:

- Scenario 1-NR350 / Scenario 1-NR500: Open space
- Scenario 3-NR350 / Scenario 3-NR500: Tunnel
- Scenario 4-BI-NR350, FR2: Open space

The high speed train conditions for the test of the baseband performance are three non-fading propagation channels. The Doppler shift varies with time as described below. For BS with Rx diversity, the Doppler shift time variation is the same for each antenna at each time instant.

For all three scenarios, the Doppler shift is given by:

$$f_s(t) = f_d \cos \theta(t) \quad (\text{J.3.1})$$

where  $f_s(t)$  is the Doppler shift and  $f_d$  is the maximum Doppler frequency.

For Scenario 1 and Scenario 3, the cosine of angle  $\theta(t)$  is given by:

$$\cos \theta(t) = \frac{D_s/2 - vt}{\sqrt{D_{\min}^2 + (D_s/2 - vt)^2}}, \quad 0 \leq t \leq D_s/v \quad (\text{J.3.2})$$

$$\cos \theta(t) = \frac{-1.5D_s + vt}{\sqrt{D_{\min}^2 + (-1.5D_s + vt)^2}}, \quad D_s/v < t \leq 2D_s/v \quad (\text{J.3.3})$$

$$\cos \theta(t) = \cos \theta(t \bmod (2D_s/v)), \quad t > 2D_s/v \quad (\text{J.3.4})$$

where  $D_s/2$  is the initial distance in metres of the train from BS, and  $D_{\min}$  is the perpendicular distance in metres from the BS to the railway track,  $v$  is the velocity of the train in m/s,  $t$  is time in seconds.

For Scenario 4, the cosine of angle  $\theta(t)$  is given by:

$$\cos \theta(t) = \frac{D_s - vt}{\sqrt{D_{\min}^2 + (D_s - vt)^2}}, \quad 0 < t \leq (0.5 * D_s)/v \quad (\text{J.3.5})$$

$$\cos \theta(t) = -\frac{vt}{\sqrt{D_{\min}^2 + (vt)^2}}, \quad (0.5 * D_s)/v < t \leq D_s/v \quad (\text{J.3.6})$$

$$\cos \theta(t) = \cos \theta \left( t \bmod \left( \frac{D_s}{v} \right) \right), \quad t > D_s/v \quad (\text{J.3.7})$$

where  $D_s$  is the initial distance of the train from BS, and  $D_{\min}$  is BS-Railway track distance, both in meters;  $v$  is the velocity of the train in m/s;  $t$  is time in seconds.

The required input parameters are listed in table J.3-1 and J.3-2. The resulting time varying Doppler shift is shown in Figure J.3-1, J.3-2, J.3-3, J.3-4, and J.3-9 for 350 km/h scenarios, and in Figure J.3-5, J.3-6, J.3-7 and J.3-8 for 500 km/h scenarios. For 350 km/h scenarios, the Doppler shift was derived such that it corresponds to a velocity of around 350 km/h for band n1 for the 15 KHz SCS, for band n77 for the 30 KHz SCS, and for band n257 for the 120 KHz SCS. For 500 km/h scenarios, the Doppler shift was derived such that it corresponds to a velocity of around 500 km/h for band n3 for the 15 KHz SCS, and for band n77 for the 30 KHz SCS. However, the same Doppler shift requirement shall be applied regardless of the frequency of operation of the base station and thus for lower frequencies, the supported speed is higher.

**Table J.3-1: Parameters for high speed train conditions for UE velocity 350 km/h**

Parameter	Value		
	Scenario 1-NR350	Scenario 3-NR350	Scenario 4-BI-NR350, FR2
$D_s$	700 m	300 m	700 m
$D_{\min}$	150 m	2 m	150 m
$v$	350 km/h	350 km/h	350 km/h
$f_d$	1340 Hz for 15 KHz SCS 2334 Hz for 30 KHz SCS	1340 Hz for 15 KHz SCS 2334 Hz for 30 KHz SCS	19444 Hz for 120 KHz SCS

**Table J.3-2: Parameters for high speed train conditions for UE velocity 500 km/h**

Parameter	Value	
	Scenario 1-NR500	Scenario 3-NR500
$D_s$	700 m	300 m
$D_{\min}$	150 m	2 m
$v$	500 km/h	500 km/h
$f_d$	1740 Hz for 15 KHz SCS 3334 Hz for 30 KHz SCS	1740 Hz for 15 KHz SCS 3334 Hz for 30 KHz SCS



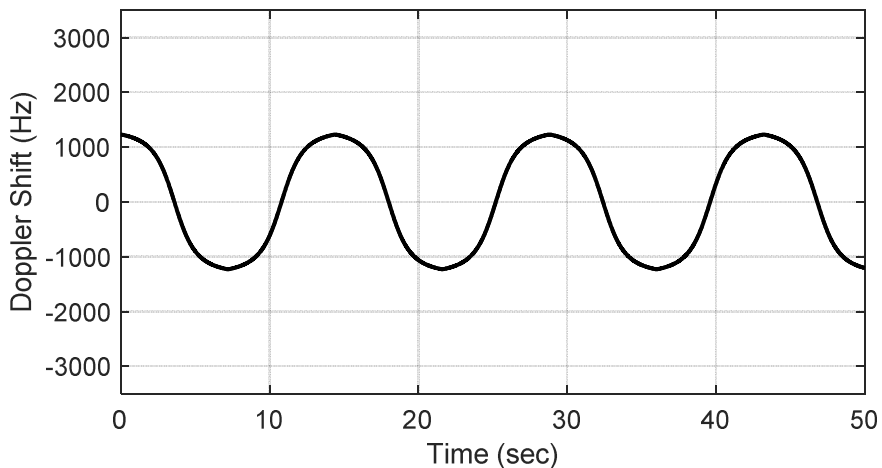

Figure J.3-1: Doppler shift trajectory for scenario 1-NR350 (15 kHz SCS)

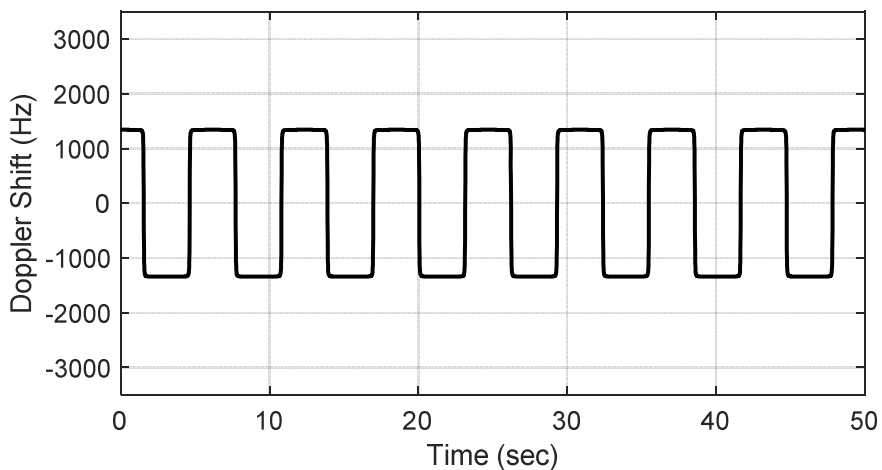

Figure J.3-2: Doppler shift trajectory for scenario 3-NR350 (15 kHz SCS)

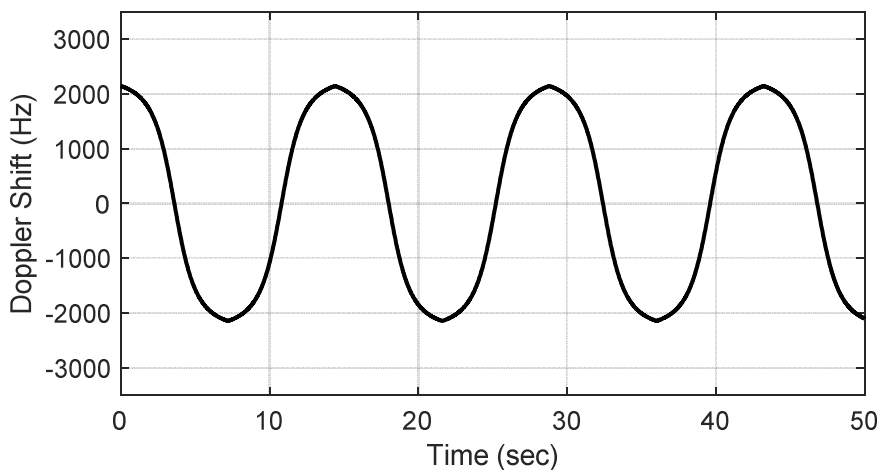

Figure J.3-3: Doppler shift trajectory for scenario 1-NR350 (30 kHz SCS)

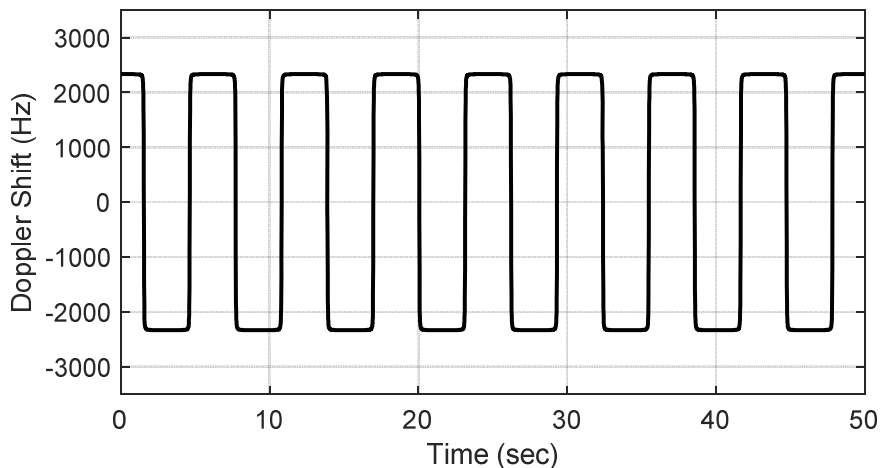

Figure J.3-4: Doppler shift trajectory for scenario 3-NR350 (30 kHz SCS)

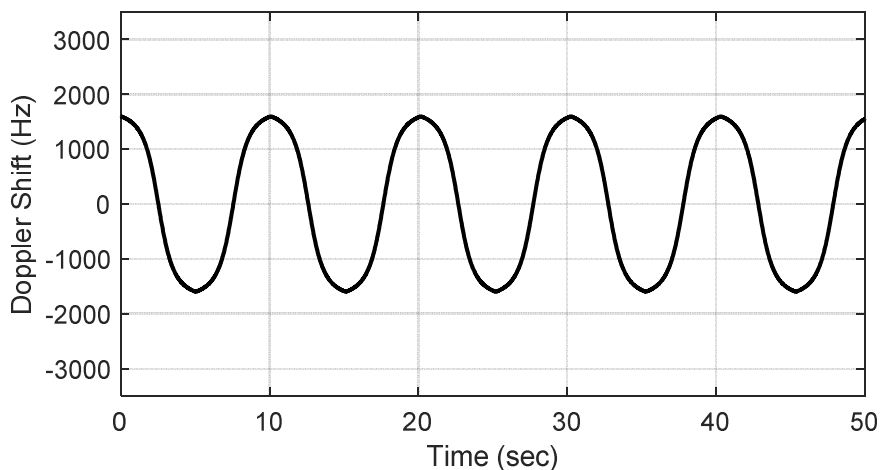

Figure J.3-5: Doppler shift trajectory for scenario 1-NR500 (15 kHz SCS)

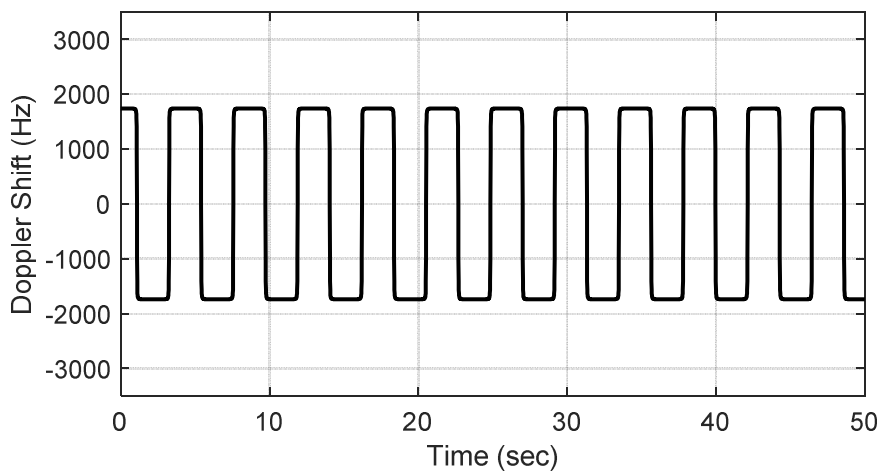

Figure J.3-6: Doppler shift trajectory for scenario 3-NR500 (15 kHz SCS)

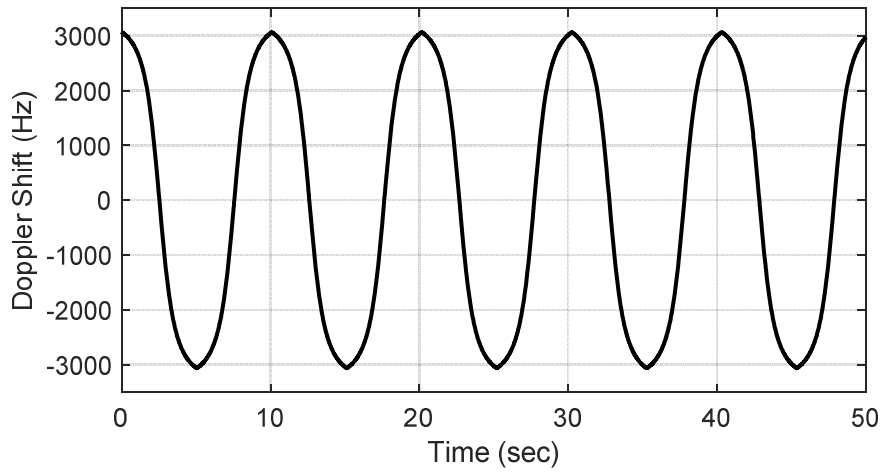

Figure J.3-7: Doppler shift trajectory for scenario 1-NR500 (30 kHz SCS)

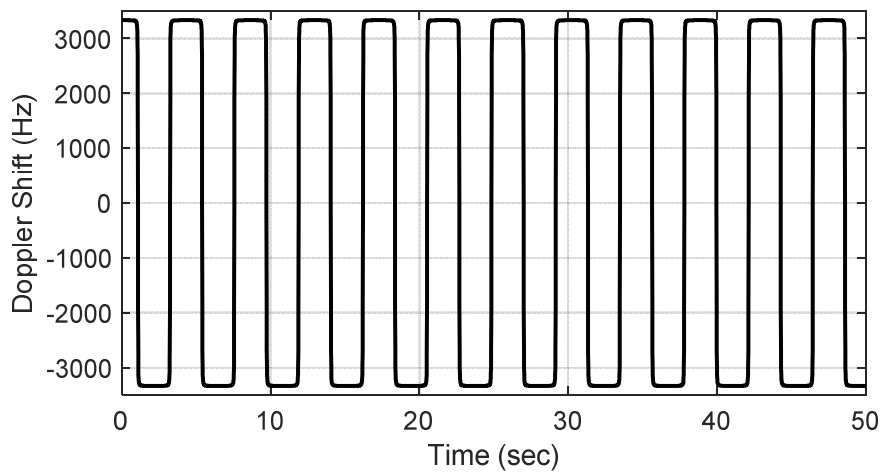

Figure J.3-8: Doppler shift trajectory for scenario 3-NR500 (30 kHz SCS)

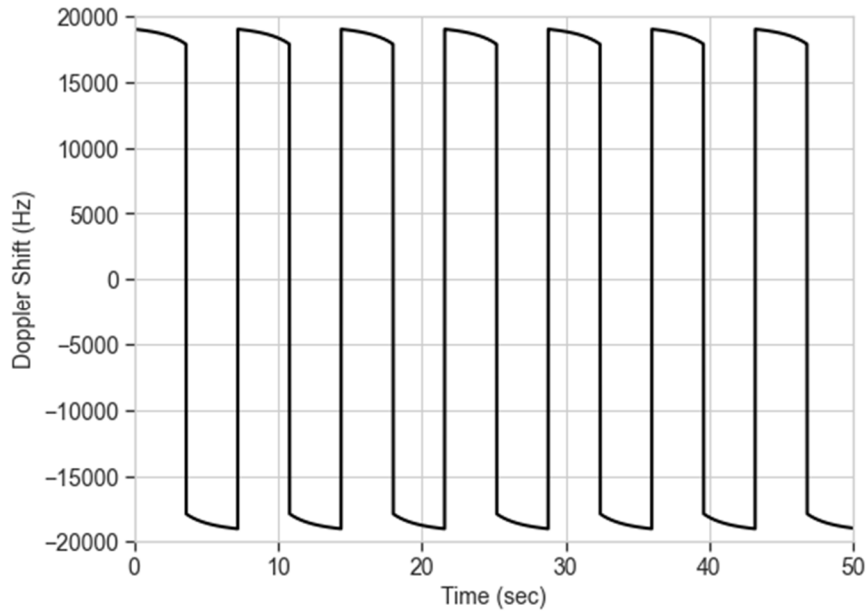

Figure J.3-9: Doppler shift trajectory for scenario 4-BI-NR350, FR2 (120 kHz SCS)

## J.4 Moving propagation conditions

Figure J.4-1 illustrates the moving propagation conditions for the test of the UL timing adjustment performance. The time difference between the reference timing and the first tap is according Equation (J.4-1). The timing difference between moving UE and stationary UE is equal to  $\Delta\tau - (T_A - 31) \times 16 \times 64 T_c$  for 15 KHz SCS,  $\Delta\tau - (T_A - 31) \times 16 \times 32 T_c$  for 30 KHz SCS and  $\Delta\tau - (T_A - 31) \times 16 \times 8 T_c$  for 120 KHz SCS. The relative timing among all taps is fixed. The parameters for the moving propagation conditions are shown in Table J.4-1.

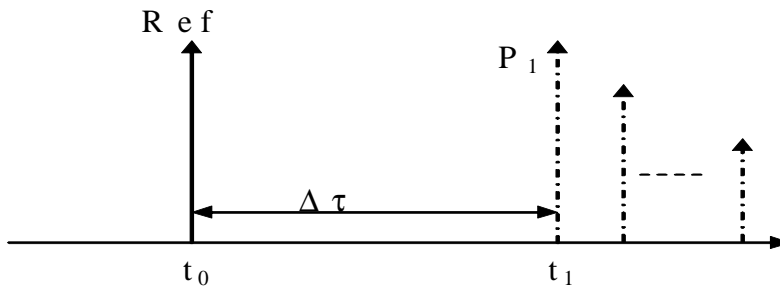

Figure J.4-1: Moving propagation conditions

$$\Delta\tau = \frac{A}{2} \cdot \sin(\Delta\omega \cdot t) \tag{J.4-1}$$

**Table J.4-1: Parameters for UL timing adjustment**

<b>Parameter</b>	<b>Scenario X</b>	<b>Scenario Y</b>	<b>Scenario Z</b>
Channel model	Stationary UE: AWGN Moving UE: TDLC300-400	Stationary UE: AWGN Moving UE: AWGN	Stationary UE: AWGN Moving UE: AWGN
UE speed	120 km/h	350 km/h	500 km/h
CP length	Normal	Normal	Normal
A	15 kHz: 10 $\mu$ s 30 kHz: 5 $\mu$ s	15 kHz: 10 $\mu$ s 30 kHz: 5 $\mu$ s 120 kHz: 1.25 $\mu$ s	15 kHz: 10 $\mu$ s 30 kHz: 5 $\mu$ s
□ □	15 kHz: 0.04 s <sup>-1</sup> 30 kHz: 0.08 s <sup>-1</sup>	15 kHz: 0.13 s <sup>-1</sup> 30 kHz: 0.26 s <sup>-1</sup> 120 kHz: 1.04 s <sup>-1</sup>	15 kHz: 0.18 s <sup>-1</sup> 30 kHz: 0.36 s <sup>-1</sup>

NOTE: Doppler shift is not taken into account in UL TA scenario Y and scenario Z.

## Annex K (informative): Measuring noise close to noise-floor

As the emission level seen by the measurement receiver ( $P_{UEM}$ ) for co-location requirements are very low, it is suggested to measure relative noise change instead of absolute noise level. For the situation where the noise level is stable, the noise level change can be identified by a relative noise measurement method. This method measures the relative noise change extracted from when the test object is operating and when the power is disconnected. From the two measured noise levels the relative noise change can be determined. The relations between measured noise change  $\delta_1$ , noise floor  $N_0$  and the relation to  $P_{UEM}$  with respect to the noise floor denoted  $\delta_2$  is visualized in the left drawing in figure K-1.

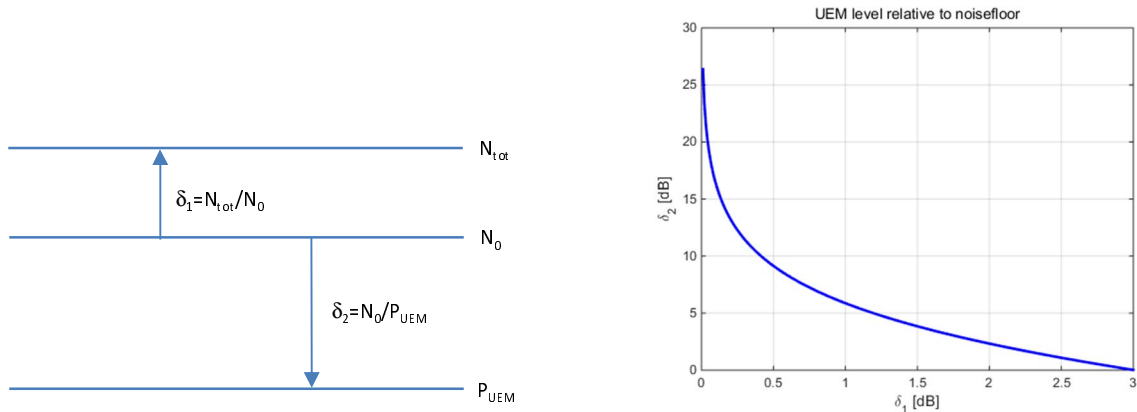

**Figure K-1: Relative noise measurement**

The absolute emission level in decibel scale is determined from a relative measurement of  $\delta_1$  as:

$$P_{UEM} = N_0 - \delta_2$$

where  $N_0$  is the noise floor of the measurement receiver and  $\delta_2$  is plotted as function of  $\delta_1$  at the right in figure K-1. The absolute noise floor of the measurement receiver, including probe antenna, cables, filter and LNA is determined by a calibration procedure. The calibration will determine the absolute emission level ( $N_0$ ) accuracy of measuring out-of-band unwanted emission close to the thermal noise floor.

---

# Annex L (normative): In-channel TX tests

## L.1 General

The in-channel TX test enables the measurement of all relevant parameters that describe the In-channel quality of the output signal of the TX under test in a single measurement process.

The parameters describing the in-channel quality of a transmitter, however, are not necessarily independent. The algorithm chosen for description inside this annex places particular emphasis on the exclusion of all interdependencies among the parameters.

---

## L.2 Basic principles

The process is based on the comparison of the actual output signal of the TX under test, received by an ideal receiver, with an ideal signal, that is generated by the measuring equipment and represents an ideal error free received signal. All signals are represented as equivalent (generally complex) baseband signals.

The description below uses numbers and illustrations as examples only. These numbers are taken from a TDD frame structure with normal CP length, 120 kHz SCS and a transmission bandwidth configuration of 400 MHz ( $N_{RB} = 264$ ). The application of the text below, however, is not restricted to this parameter set.

### L.2.1 Output signal of the TX under test

The output signal of the TX under test is acquired by the measuring equipment and stored for further processing. It is sampled at a sampling rate which is the product of the SCS and the *FFT size*, and it is named  $z(v)$ .

For FR1, *FFT size* is determined by the transmission bandwidth in TS 38.141-1 [3] table 6.5.3.5-2 for 15 kHz SCS, table 6.5.3.5-3 for 30 kHz SCS and table 6.5.3.5-4 for 60 kHz SCS.

For FR2, *FFT size* is determined by the transmission bandwidth in table 6.6.3.5.2-2 for 60 kHz SCS, table 6.6.3.5.2-3 for 120 kHz SCS, table 6.6.3.5.2-4 for 480 kHz SCS and table 6.6.3.5.2-5 for 960 kHz SCS. In the time domain it comprises at least 10 ms for FR1 and FR2-1 and at least 80 slots for FR2-2. It is modelled as a signal with the following parameters:

- demodulated data content,
- carrier frequency,
- amplitude and phase for each subcarrier.

For the example in the annex, the *FFT size* is 4096 based on table 6.6.3.5.2-3. The sampling rate of 491.52 Msps is the product of the *FFT size* and SCS.

### L.2.2 Ideal signal

Two types of ideal signals are defined:

The first ideal signal  $i_1(v)$  is constructed by the measuring equipment according to the relevant TX specifications, using the following parameters:

- demodulated data content,
- nominal carrier frequency,
- nominal amplitude and phase for each subcarrier.

It is represented as a sequence of samples at the sampling rate determined from annex L.2.1 in the time domain. The structure of the signal is described in the test models.

The second ideal signal  $i_2(v)$  is constructed by the measuring equipment according to the relevant TX specifications, using the following parameters for FR1 and FR2:

- nominal demodulation reference signal and nominal PT-RS if present (all other modulation symbols are set to 0 V),
- nominal carrier frequency,
- nominal amplitude and phase for each applicable subcarrier,
- nominal timing.

It is represented as a sequence of samples at the sampling rate determined from annex L.2.1 in the time domain.

### L.2.3 Measurement results

The measurement results, achieved by the in-channel TX test are the following:

- Carrier frequency error.
- EVM.
- Resource element TX power.
- OFDM symbol TX power (OSTP).

Other side results are: residual amplitude- and phase response of the TX chain after equalisation.

### L.2.4 Measurement points

The resource element TX power is measured after the FFT box as described in figure L.2.4-1 for FR1 and in figure L.2.4.2. The EVM shall be measured at the point after the FFT and a zero-forcing (ZF) equalizer in the receiver, as depicted in for FR1 in figure L.2.4-1 and for FR2 in figure L.2.4-2. The FFT window of  $FFT\ size$  samples out of ( $FFT\ size + cyclic\ prefix\ length$ ) samples in the time domain is selected in the "Remove CP" box.

For FR1, The  $FFT\ size$  and the cyclic prefix length are obtained from TS 38.141-1 [3] table 6.5.3.5-2 for 15 kHz SCS, table 6.5.3.5-3 for 30 kHz SCS and table 6.5.3.5-4 for 60 kHz SCS.

For FR2,  $FFT\ size$  and the cyclic prefix length is determined from table 6.6.3.5.2-2 for 60 kHz SCS, table 6.6.3.5.2-3 for 120 kHz SCS, table 6.6.3.5.2-4 for 480 kHz SCS and table 6.6.3.5.2-5 for 960 kHz SCS.

In one subframe, there are two symbols with the length of the cyclic prefix larger than the values listed in TS 38.141-1 [3] tables 6.5.3.5-2, 6.5.3.5-3 and 6.5.3.5-4 for FR1 and tables 6.6.3.5.2-2, table 6.6.3.5.2-3, table 6.6.3.5.2-4 and table 6.6.3.5.2-5 for FR2. Table L.2.4-1 lists the slot number and the symbol number and the formula how to compute the length of cyclic prefix for those two symbols according to the sampling rate.



**Table L.2.4-1: Slot number and symbol number identifying the longer CP length for normal CP**

SCS (kHz)	Frequency Range	# slots in subframe	Symbol # and slot # with longer CP	Longer CP length
15	FR1	1	(symbol 0, slot 0) (symbol 7, slot 0)	CP length + FFT size / 128
30		2	(symbol 0, slot 0) (symbol 0, slot 1)	CP length + FFT size / 64
60		4	(symbol 0, slot 0) (symbol 0, slot 2)	CP length + FFT size / 32
60	FR2-1	4	(symbol 0, slot 0) (symbol 0, slot 2)	CP length + FFT size / 32
120		8	(symbol 0, slot 0) (symbol 0, slot 4)	CP length + FFT size / 16
120	FR2-2	8	(symbol 0, slot 0) (symbol 0, slot 4)	CP length + FFT size / 16
480		32	(symbol 0, slot 0) (symbol 0, slot 16)	CP length + FFT size / 4
960		64	(symbol 0, slot 0) (symbol 0, slot 32)	CP length + FFT size / 2

For the example used in the annex, the "Remove CP" box selects 4096 samples out of 4384 samples. Symbol 0 of slot 0 and slot 4 has 256 more samples in the cyclic prefix than the other symbols (the longer CP length = 544).

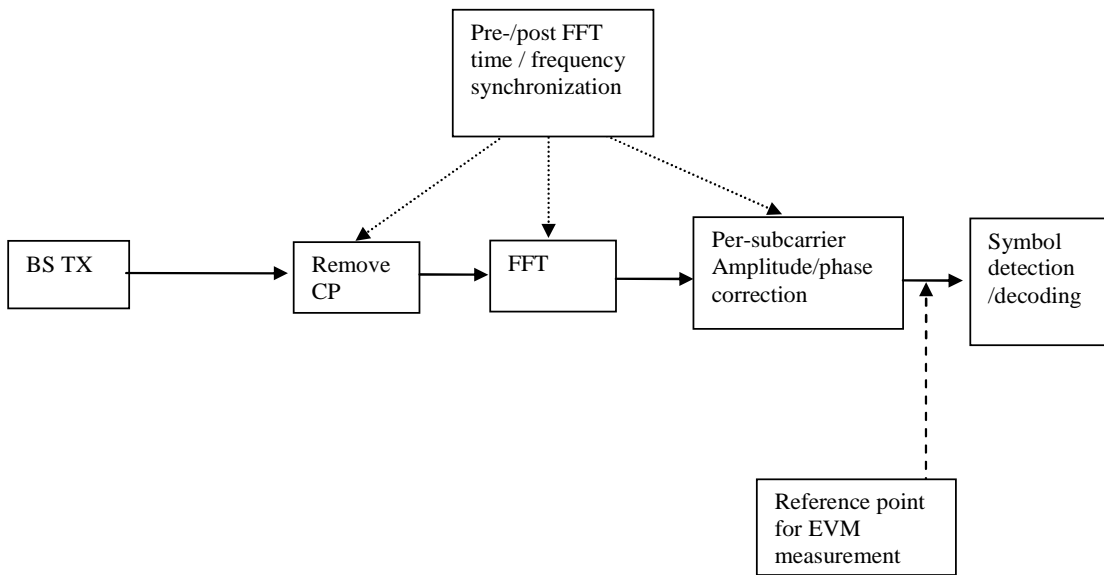

**Figure L.2.4-1: Reference point for FR1 EVM measurements**

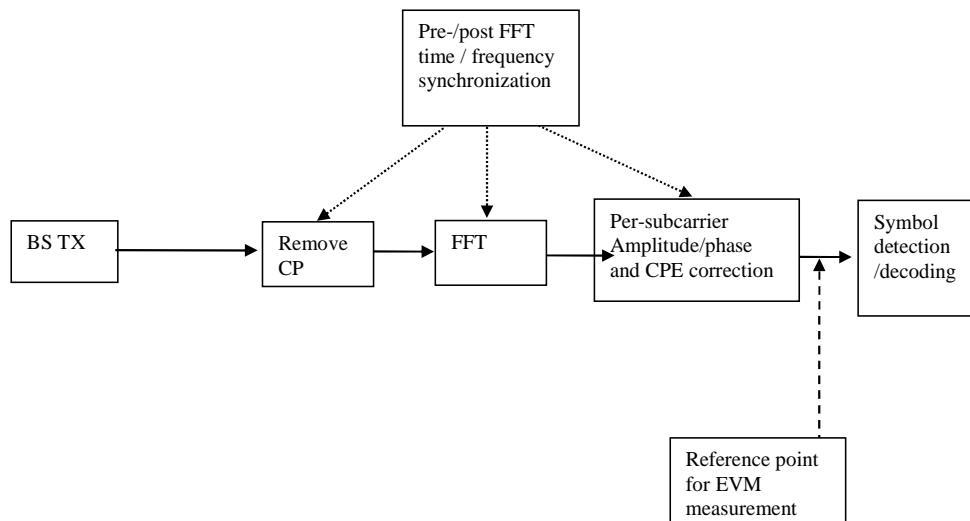

Figure L.2.4-2: Reference point for FR2 EVM measurements

## L.3 Pre-FFT minimization process

Sample timing, carrier frequency in  $z(v)$  are varied in order to minimise the difference between  $z(v)$  and  $i_1(v)$ , after the amplitude ratio of  $z(v)$  and  $i_1(v)$  has been scaled. Best fit (minimum difference) is achieved when the RMS difference value between  $z(v)$  and  $i_1(v)$  is an absolute minimum.

The carrier frequency variation is the measurement result: carrier frequency error.

From the acquired samples, one value of carrier frequency error can be derived.

NOTE 1: The minimisation process, to derive the RF error can be supported by post-FFT operations. However the minimisation process defined in the pre-FFT domain comprises all acquired samples (i.e. it does not exclude the samples inbetween the FFT widths and it does not exclude the bandwidth outside the transmission bandwidth configuration).

NOTE 2: The algorithm would allow to derive carrier frequency error and sample frequency error of the TX under test separately. However there are no requirements for sample frequency error. Hence the algorithm models the RF and the sample frequency commonly (not independently). It returns one error and does not distinguish between both.

After this process the samples  $z(v)$  are called  $z^0(v)$ .

## L.4 Timing of the FFT window

The FFT window length is *FFT size* samples per OFDM symbol. For FDD, there are  $14N_{dt}$  FFTs performed where  $N_{dt}$  is the number of slots in a 10 ms measurement interval, and the number of symbols in a slot for normal CP is 14. For TDD, the number of FFTs performed is the number of downlink symbols in the measurement interval.

The position in time for the FFT shall be determined.

For the example used in the annex, the FFT window length is 4096 samples per OFDM symbol. 832 FFTs (i.e. 3,407,872 samples) cover less than the acquired number of samples (i.e. 3,651,584 samples in 10 ms). There are 816 symbols with 4384 samples and 16 symbols with 4640 samples.

In an ideal signal, the FFT may start at any instant within the cyclic prefix without causing an error. The TX filter, however, reduces the window. The EVM requirements shall be met within a window  $W < CP$ . There are three different instants for FFT:

- Centre of the reduced window, called  $\Delta\tilde{c}$ ,

- $\Delta c - W/2$ , and
- $\Delta c + W/2$ .

The value of EVM window length  $W$  is obtained from the transmission bandwidth and TS 38.141-1 [3] table 6.5.3.5-2 for 15 kHz SCS, table 6.5.3.5-3 for 30 kHz SCS and table 6.5.3.5-4 for 60 kHz SCS for FR1, and table 6.6.3.5.2-2 for 60 kHz SCS, table 6.6.3.5.2-3 for 120 kHz SCS, table 6.6.3.5.2-4 for 480 kHz SCS and table 6.6.3.5.2-5 for 960 kHz SCS for FR2.

The BS shall transmit a signal according to the test models intended for EVM. The demodulation reference signal of the second ideal signal shall be used to find the centre of the FFT window.

The timing of the measured signal is determined in the pre FFT domain as follows, using  $z^0(v)$  and  $i_2(v)$ :

1. The measured signal is delay spread by the TX filter. Hence the distinct borders between the OFDM symbols and between data and CP are also spread and the timing is not obvious.
2. In the ideal signal  $i_2(v)$ , the timing is known.

Correlation between bullet (1) and (2) will result in a correlation peak. The meaning of the correlation peak is approximately the "impulse response" of the TX filter.

3. The meaning of "impulse response" assumes that the autocorrelation of the ideal signal  $i_2(v)$  is a Dirac peak and that the correlation between the ideal signal  $i_2(v)$  and the data in the measured signal is 0. The correlation peak, (the highest, or in case of more than one highest, the earliest) indicates the timing in the measured signal.

The number of samples, used for FFT is reduced compared to  $z^0(v)$ . This subset of samples is called  $z'(v)$ .

From the acquired samples one timing can be derived.

The timing of the centre  $\Delta\tilde{c}$  is determined according to the cyclic prefix length of the OFDM symbols. For normal CP, there are two values for  $\Delta\tilde{c}$  in a 1 ms period:

- $\Delta\tilde{c} = \text{length of cyclic prefix} / 2$ ,
- $\Delta\tilde{c} = \text{Longer CP length} - \text{length of cyclic prefix} / 2$ ,

Where the length of cyclic prefix is obtained from TS 38.141-1 [3] table 6.5.3.5-2 for 15 kHz SCS, table 6.5.3.5-3 for 30 kHz SCS and table 6.5.3.5-4 for 60 kHz SCS for FR1, and table 6.6.3.5.2-2 for 60 kHz SCS, table 6.6.3.5.2-3 for 120 kHz SCS, table 6.6.3.5.2-4 for 480 kHz SCS and table 6.6.3.5.2-5 for 960 kHz SCS for FR2, and the longer CP length is obtained from table L.2.4-1.

As per the example values.

- $\Delta\tilde{c} = 144$  within the CP of length 288 for most OFDM symbols in 1 ms,
- $\Delta\tilde{c} = 400 (= 544 - 144)$  within the CP of length 544 for OFDM symbol 0 of slot 0 and slot 4.

---

## L.5 Resource element TX power

Perform FFT on  $z'(v)$  with the FFT window timing  $\Delta\tilde{c}$ .

The result is called  $Z'(t, f)$ . The RE TX (RETP) power is then defined as:

$$RETP = |Z'(t, f)|^2 \text{SCS}$$

where SCS is the subcarrier spacing in Hz.

From RETP, the OFDM symbol TX power (OSTP) is derived as follows:

$$OSTP = \frac{1}{N_{sym}} \sum RETP$$

Where the summation accumulates  $N_{RB}N_{sc}^{RB}$  values of all  $N_{sym}$  OFDM symbols that carry PDSCH and not containing PDCCH, RS or SSB within a slot.

$$N_{sc}^{RB} = 12.$$

From the acquired samples  $N_{dl}$  values for each OSTP can be obtained and averaged where  $N_{dl}$  is the number of slots in a 10 ms measurement interval for FDD. For TDD,  $N_{dl}$  is the number of slots with downlink symbols in a 10 ms measurement interval for FR1 and FR2-1, in an 80 slots measurement interval for FR2-2 and is computed according to the values in table 4.9.2.2-1.

For the example used in the annex,  $N_{dl} = 64$  and  $N_{RB} = 264$ .

## L.6 Post-FFT equalisation

Perform  $14N_{dl}$  FFTs on  $z'(v)$ , one for each OFDM symbol within 10 ms for FR1 and FR2-1, and 80 slots measurement interval for FR2-2 measurement interval with the FFT window timing to produce an array of samples,  $14N_{dl}$  in the time axis  $t$  by *FFT size* in the frequency axis  $f$ .

For the example in the annex, 1120 FFTs are performed on  $z'(v)$ . The result is an array of samples, 1120 in the time axis by 4096 in the frequency axis.

The equalizer coefficients  $\tilde{a}(f)$  and  $\tilde{\varphi}(f)$  are determined as follows:

1. Calculate the complex ratios (amplitude and phase) of the post-FFT acquired signal  $Z'(t, f)$  and the post-FFT ideal signal  $I_2(t, f)$ , for each demodulation reference signal, over 10 ms measurement interval for FR1 and FR2-1, and 80 slots measurement interval for FR2-2. This process creates a set of complex ratios:

$$a(t, f)e^{j\varphi(t, f)} = \frac{Z'(t, f)}{I_2(t, f)}$$

2. Perform time averaging at each demodulation reference signal subcarrier of the complex ratios, the time-averaging length is 10 ms measurement interval for FR1 and FR2-1, and 80 slots measurement interval for FR2-2. Prior to the averaging of the phases  $\varphi(t_i, f)$  an unwrap operation must be performed according to the following definition:
  - The unwrap operation corrects the radian phase angles of  $\varphi(t_i, f)$  by adding multiples of  $2 * \pi$  when absolute phase jumps between consecutive time instances  $t_i$  are greater than or equal to the jump tolerance of  $\pi$  radians.
  - This process creates an average amplitude and phase for each demodulation reference signal subcarrier (i.e. every second subcarrier).

$$a(f) = \frac{\sum_{i=1}^N a(t_i, f)}{N}$$

$$\varphi(f) = \frac{\sum_{i=1}^N \varphi(t_i, f)}{N}$$

Where  $N$  is the number of demodulation reference signal time-domain locations  $t_i$  from  $Z'(t, f)$  for each demodulation reference signal subcarrier  $f$ .

3. The equalizer coefficients for amplitude and phase  $\hat{a}(f)$  and  $\hat{\varphi}(f)$  at the demodulation reference signal subcarriers are obtained by computing the moving average in the frequency domain of the time-averaged demodulation reference signal subcarriers. The moving average window size is 19 and averaging is over the DM-RS subcarriers in the allocated RBs. For DM-RS subcarriers at or near the edge of the channel, or when the number of available DM-RS subcarriers within a set of contiguously allocated RBs is smaller than the moving average window size, the window size is reduced accordingly as per figure L.6-1.
4. Perform linear interpolation from the equalizer coefficients  $\hat{a}(f)$  and  $\hat{\varphi}(f)$  to compute coefficients  $\tilde{a}(f)$ ,  $\tilde{\varphi}(f)$  for each subcarrier.

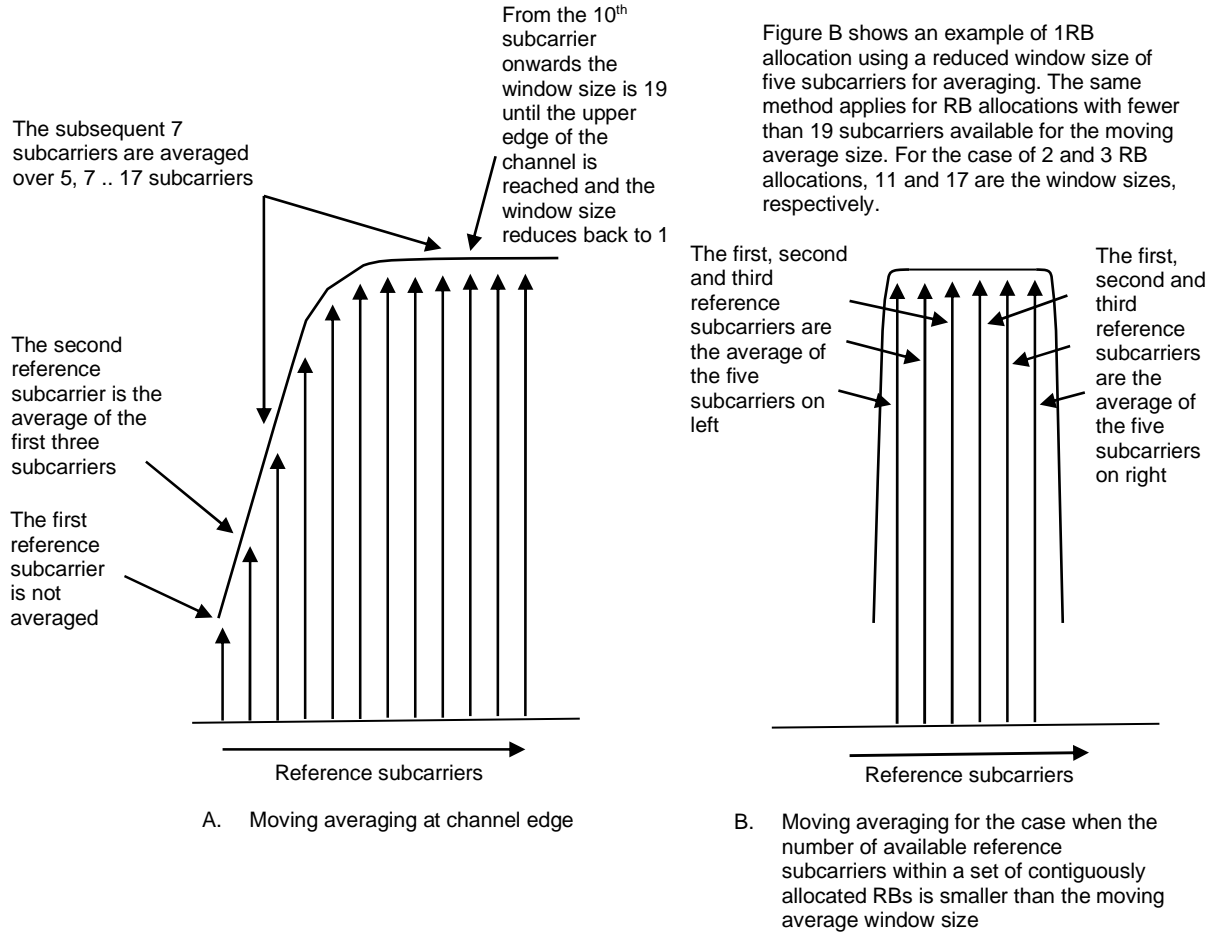

**Figure L.6-1: Reference subcarrier smoothing in the frequency domain**

- a) In case of FR2 EVM, to account for the common phase error (CPE) experienced in millimetre wave frequencies,  $\bar{\varphi}(f)$ , in the estimated coefficients contain phase rotation due to the CPE,  $\theta$ , in addition to the phase of the equalizer coefficient  $\tilde{\varphi}(f)$ , that is:

$$\bar{\varphi}(f) = \tilde{\varphi}(f) + \theta(t)$$

For OFDM symbols where PT-RS does not exist,  $\theta(t)$  can be estimated by performing linear interpolation from neighboring symbols where PT-RS is present.

In order to separate component of the CPE,  $\theta$ , contained in,  $\bar{\varphi}(f)$ , estimation and compensation of the CPE needs to follow.  $\theta(t)$  is the common phase error (CPE), that rotates all the subcarriers of the OFDM symbol at time  $t$ .

Estimate of the CPE,  $\theta(t)$ , at OFDM symbol time,  $t$ , can then be obtained from using the PT-RS employing the expression:

$$\tilde{\theta}(t) = \arg \left\{ \sum_{f \in f^{ptrs}} \left( \frac{Z'(t,f)}{I_{ptrs}(t,f)} \right) (\tilde{a}(f) e^{-j\bar{\varphi}(f)}) \right\}$$

In the above equation,  $f^{ptrs}$  is the set of subcarriers where PT-RS are mapped,  $t \in t^{ptrs}$  where  $t^{ptrs}$  is the set of OFDM symbols where PT-RS are mapped while  $Z'(t, f)$  and  $I_{ptrs}(t, f)$  are is the post-FFT acquired signal and the ideal PT-RS signal respectively. That is, estimate of the CPE at a given OFDM symbol is obtained from frequency correlation of the complex ratios at the PT-RS positions with the conjugate of the estimated equalizer complex coefficients. The estimated CPE can be subtracted from  $\bar{\varphi}(f)$  to remove influence of the CPE, and obtain estimate of the complex coefficient's phase:

$$\tilde{\varphi}(f) = \bar{\varphi}(f) - \tilde{\theta}(t)$$

## L.7 EVM

### L.7.0 General

For EVM create two sets of  $Z_{eq}'(t, f)$ , according to the timing  $(\Delta c - W/2)$  and  $(\Delta c + W/2)$ , using the equalizer coefficients from L.6.

The equivalent ideal samples are calculated from  $i_1(v)$  (annex L.2.2) and are called  $I(t, f)$ .

The EVM is the difference between the ideal signal and the equalized measured signal.

$$EVM = \sqrt{\frac{\sum_{t \in T} \sum_{f \in F(i)} |Z_{eq}'(t, f) - I(t, f)|^2}{\sum_{t \in T} \sum_{f \in F(i)} |I(t, f)|^2}}$$

Where:

- $T$  is the set of symbols with the considered modulation scheme being active within the slot,
- $F(t)$  is the set of subcarriers within the resource blocks with the considered modulation scheme being active in symbol  $t$ ,
- $I(t, f)$  is the ideal signal reconstructed by the measurement equipment in accordance with relevant test models,
- $Z_{eq}'(t, f)$  is the equalized signal under test.

NOTE: Although the basic unit of measurement is one slot, the equalizer is calculated over the entire 10 ms measurement interval for FR1 and FR2-1, and over the entire 80 slots measurement interval for FR2-2 to reduce the impact of noise in the reference signals.

### L.7.1 Averaged EVM (FDD)

EVM is averaged over all allocated downlink resource blocks with the considered modulation scheme in the frequency domain, and a minimum of  $N_{dl}$  downlink slots where  $N_{dl}$  is the number of slots in a 10 ms measurement interval.

The averaging in the time domain equals the  $N_{dl}$  slot duration of the 10 ms measurement interval from the equalizer estimation step.

$$\overline{EVM}_{\text{frame}} = \sqrt{\frac{1}{\sum_{i=1}^{N_{dl}} N_i} \sum_{i=1}^{N_{dl}} \sum_{j=1}^{N_i} EVM_{i,j}^2}$$

Where  $N_i$  is the number of resource blocks with the considered modulation scheme in subframe  $i$ .

The EVM requirements shall be tested against the maximum of the RMS average at the window  $W$  extremities of the EVM measurements:

Thus  $\overline{EVM}_{\text{frame},l}$  is calculated using  $\tilde{t} = \Delta \tilde{t}_l$  in the expressions above and  $\overline{EVM}_{\text{frame},h}$  is calculated using  $\tilde{t} = \Delta \tilde{t}_h$  in the  $\overline{EVM}_{\text{frame}}$  calculation where ( $l$  and  $h$ , low and high; where low is the timing  $(\Delta c - W/2)$  and high is the timing  $(\Delta c + W/2)$ ).

Thus:

$$\overline{EVM} = \max(\overline{EVM}_{\text{frame},l}, \overline{EVM}_{\text{frame},h})$$

The resulting  $\overline{EVM}$  is compared against the limit.

## L.7.2 Averaged EVM (TDD) for FR1 and FR2-1

Let  $N_{dl}^{TDD}$  be the number of slots with downlink symbols within a 10 ms measurement interval. For TDD, the averaging in the time domain can be calculated from  $N_{dl}^{TDD}$  slots of different 10 ms measurement intervals and should have a minimum of  $N_{dl}$  slots averaging length where  $N_{dl}$  is the number of slots in a 10 ms measurement interval.

$\overline{EVM}_{frame}$  is derived by: Square the EVM results in each 10 ms measurement interval. Sum the squares, divide the sum by the number of EVM relevant locations, square-root the quotient (RMS).

$$\overline{EVM}_{frame} = \sqrt{\frac{1}{\sum_{i=1}^{N_{dl}^{TDD}} \sum_{j=1}^{N_i} EVM_{i,j}^2}}$$

Where  $N_i$  is the number of resource blocks with the considered modulation scheme in slot  $i$ .

The  $\overline{EVM}_{frame}$  is calculated, using the maximum of  $\overline{EVM}_{frame}$  at the window  $W$  extremities. Thus  $\overline{EVM}_{frame,l}$  is calculated using  $\tilde{t} = \Delta\tilde{t}_l$  and  $\overline{EVM}_{frame,h}$  is calculated using  $\tilde{t} = \Delta\tilde{t}_h$  ( $l$  and  $h$ , low and high; where low is the timing ( $\Delta c - W/2$ ) and and high is the timing ( $\Delta c + W/2$ )).

$$EVM_{frame} = \max(\overline{EVM}_{frame,l}, \overline{EVM}_{frame,h})$$

In order to unite at least  $N_{dl}$  slots, consider the minimum integer number of 10 ms measurement intervals, where  $N_{frame}$  is determined by

$$N_{frame} = \left\lceil \frac{10 \times N_{slot}}{N_{dl}^{TDD}} \right\rceil$$

And for FR1,  $N_{slot} = 1$  for 15 kHz SCS,  $N_{slot} = 2$  for 30 kHz SCS and  $N_{slot} = 4$  for 60 kHz SCS normal CP. For FR2,  $N_{slot} = 4$  for 60 kHz SCS and  $N_{slot} = 8$  for 120 kHz SCS.

Unite by RMS.

$$\overline{EVM} = \sqrt{\frac{1}{N_{frame}} \sum_{k=1}^{N_{frame}} EVM_{frame,k}^2}$$

The resulting  $\overline{EVM}$  is compared against the limit.

## L.7.3 Averaged EVM (TDD) for FR2-2

Let  $N_{dl}^{TDD}$  be the number of slots with downlink symbols within a 80 slots measurement interval. For TDD, the averaging in the time domain can be calculated from  $N_{dl}^{TDD}$  slots of different measurement intervals and should have a minimum of 80 slots averaging length for FR2-2.

$\overline{EVM}_{80slots\_period}$  is derived by: Square the EVM results in each one measurement interval. Sum the squares, divide the sum by the number of EVM relevant locations, square-root the quotient (RMS).

$$\overline{EVM}_{80slots\_period} = \sqrt{\frac{1}{\sum_{i=1}^{N_{dl}^{TDD}} \sum_{j=1}^{N_i} EVM_{i,j}^2}}$$

Where  $N_i$  is the number of resource blocks with the considered modulation scheme in slot  $i$ .

The  $\overline{EVM}_{80slots\_period}$  is calculated, using the maximum of  $\overline{EVM}_{80slots\_period}$  at the window  $W$  extremities. Thus  $\overline{EVM}_{80slots\_period,l}$  is calculated using  $\tilde{t} = \Delta\tilde{t}_l$  and  $\overline{EVM}_{80slots\_period,h}$  is calculated using  $\tilde{t} = \Delta\tilde{t}_h$  ( $l$  and  $h$ , low and high; where low is the timing ( $\Delta c - W/2$ ) and and high is the timing ( $\Delta c + W/2$ )).

$$EVM_{80slots\_period} = \max(\overline{EVM}_{80slots\_period,l}, \overline{EVM}_{80slots\_period,h})$$

In order to unite at least 80 slots, consider the minimum integer number of 80 slots measurement intervals, where  $N_{80slots\_period}$  is determined by

$$N_{80slots\_period} = \left\lceil \frac{80}{N_{dt}^{TDD}} \right\rceil$$

Unite by RMS.

$$\overline{EVM} = \sqrt{\frac{1}{N_{80slots\_period}} \sum_{k=1}^{N_{80slots\_period}} EVM_{80slots\_period,k}^2}$$

The resulting  $\overline{EVM}$  is compared against the limit.



---

## Annex M (normative): General rules for statistical testing

### M.1 Testing methodology of PUSCH performance requirements with 0.001% BLER

#### M.1.1 General

The test framework for the 0.001% BLER test is based upon examining received blocks and determining pass, fail or continue each time a block error occurs.

The pass/fail decision is made based on so-called decision co-ordinates ( $n_e$ ,  $n_s$ ).  $n_e$  is the number of block errors encountered during the test and  $n_s$  is the total number of received blocks during the test, up to the current block error. The  $n_s$  is compared with the  $n_{sp}$  and  $n_{sf}$  entries corresponding to  $n_e$  in table M.1.1-1. If  $n_s$  is greater than the  $n_{sp}$  value in M.1.1-1, a pass may be declared. If  $n_s$  is lower than the  $n_{sf}$  value, a fail may be declared. Otherwise, the test continues.

The objective of the approach is to minimize testing time and the basis of the approach is an early termination statistical framework described in clause M.1.3.1. The minimum testing time is defined by the possible decision coordinates detailed in clause M.1.2.

As with all statistical tests, there is a non-zero risk of the test result being incorrect due to statistical variations. There are two possibilities for an incorrect decision:

- As BS, whose BLER is greater than the requirement (i.e., the BS does not comply to the requirement), is declared to pass the test.
- A BS, whose BLER is lower than the requirement (i.e., a BS that does comply to the requirement), is declared to fail the test.

The outcome of the statistical test is a decision. This decision may be correct with confidence level of 99.999%, i.e., BSs whose BLER is greater than 0.001% being declared to fail, and BSs whose BLER is smaller or equal to 0.001% being declared to pass, or in-correct (as detailed above).

## M.1.2 Numerical definition of the pass-fail limits for testing PUSCH 0.001% BLER

Table M.1.2-1: Pass fail limits

ne	ns <sub>p</sub>	ns <sub>f</sub>	ne	ns <sub>p</sub>	ns <sub>f</sub>	ne	ns <sub>p</sub>	ns <sub>f</sub>
0	1074532	1067	39	5369517	1508043	(*)	(*)	(*)
1	1074532	1067	40	5463478	1568438	608	49669522	49113220
2	1274645	1067	41	5557107	1629304	609	49743206	49202955
3	1444583	1067	42	5650414	1690627	610	49816884	49292699
4	1599072	4727	43	5743410	1752389	611	49890556	49382451
5	1743641	12160	44	5836108	1814577	612	49964222	49472211
6	1881111	23683	45	5928516	1877177	613	50037883	49561980
7	2013164	39190	46	6020643	1940175	614	50111538	49651757
8	2140902	58403	47	6112500	2003560	615	50185187	49741542
9	2265092	81000	48	6204094	2067319	616	50258831	49831335
10	2386297	106667	49	6295434	2131442	617	50332469	49921137
11	2504945	135116	50	6386526	2195916	618	50406101	50010947
12	2621369	166089	51	6477380	2260734	619	50479728	50100765
13	2735834	199360	52	6568000	2325884	620	50553349	50190592
14	2848557	234730	53	6658395	2391358	621	50626965	50280427
15	2959718	272025	54	6748569	2457146	622	50700575	50370269
16	3069467	311091	55	6838530	2523241	623	50774179	50460120
17	3177931	351792	56	6928283	2589634	624	50847778	50549980
18	3285220	394009	57	7017834	2656318	625	50921372	50639847
19	3391428	437636	58	7107187	2723285	626	50994959	50729722
20	3496637	482577	59	7196348	2790528	627	51068542	50819605
21	3600921	528746	60	7285321	2858041	628	51142119	50909497
22	3704343	576068	61	7374112	2925816	629	51215690	50999396
23	3806960	624473	62	7462724	2993848	630	51289256	51089304
24	3908823	673898	63	7551162	3062130	631	51362816	51179219
25	4009977	724286	64	7639430	3130657	632	51436371	51269143
26	4110465	775585	65	7727532	3199424	633	51509921	51359074
27	4210324	827748	66	7815471	3268424	634	51583465	51449013
28	4309587	880730	67	7903252	3337653	635	51657003	51538961
29	4408285	934492	68	7990878	3407105	636	51730537	51628916
30	4506448	988997	69	8078352	3476777	637	51804065	51718879
31	4604101	1044211	70	8165677	3546663	638	51877587	51808850
32	4701268	1100101	71	8252857	3616759	639	51951104	51898828
33	4797972	1156638	72	8339894	3687060	640	52024616	51988815
34	4894232	1213795	73	8426792	3757563	641	52098123	52078809
35	4990069	1271547	74	8513553	3828263	642	52171624	52168811
36	5085500	1329869	75	8600181	3899156			
37	5180542	1388740	76	8686677	3970239			
38	5275209	1448137	77	8773044	4041508	*) Follow M.1.3.2 to derive		

NOTE 1: The first column is the number of errors (ne = number of NACK)

NOTE 2: The second column is the number of samples for the pass limit (ns<sub>p</sub>, ns=Number of Samples= number of NACK + ACK)

NOTE 3: The third column is the number of samples for the fail limit (ns<sub>f</sub>)

NOTE 4: An ideal EUT passes after 1074532 samples. The maximum test time is 52171625 samples. A EUT passes, if the maximum number of samples is reached and it did not fail before.

### M.1.3 Theory to derive the early pass/fail limits in M.1.2 (informative)

#### M.1.3.1 Numerical definition of the pass-fail limits for testing PUSCH 0.001% BLER

A statistical test is characterized by test time, selectivity and confidence level. The outcome of the statistical test is a decision. This decision may be correct, i.e., BSs whose BLER is greater than 0.001% being declared to fail, and BSs whose BLER is smaller or equal to 0.001% being declared to pass, or in-correct (as detailed above). The Confidence Level (CL) describes the probability that the decision is a correct one. The complement is the wrong decision probability (risk)  $D = 1 - CL$ .

When testing BLER, transport blocks or "samples" are observed and the numbers of correctly and erroneously received blocks are recorded. For a "standard" test, a pre-defined number of samples are observed, and a pass/fail decision is made based on the number of observed errors being above/below a threshold. This threshold is based on the targeted BLER and the design target CL. There is always some risk of a statistical variation leading to an incorrect pass/fail decision. The greater the number of samples that are recorded, the lower is the risk of such an error. The number of samples that are observed in a standard test is dimensioned to achieve an acceptable low risk of error (i.e., an acceptable high confidence level) for BS that just meet the BLER limit.

The standard test works well where the BLER level is relatively high and confidence level relatively low (both are chosen to be on a comparable order of magnitude). However, for ultra-low BLER testing the length of time required for observing sufficient samples to achieve a 99.999% confidence level is excessive. In many cases, the BS will in fact have a much lower true BLER than the limit, i.e., design target of the test, (in which case, the number of samples needed to achieve high confidence that the BLER is lower than the limit is much smaller) or, if failing the requirement will have a much higher true BLER (in which case, errors occur more frequently and it can be demonstrated that the BS is above the BLER limit with fewer samples).

To avoid long test times, an alternative test method called early pass/fail is adopted. With the early pass/fail, each time a block error is encountered, a decision is made on whether the BS can be passed/failed with 99.999% CL or the test needs to continue until another error is encountered. In the case of very good BSs, the test can also be passed, when the number of samples permissible for one error event is reached and no error event is recorded. Pass/Fail is decided based on the total number of observed samples and errors, and a statistical calculation based on an inverse binomial cumulative distribution. The calculation involves one parameter, one variable and the result:

- Parameter:  $d$  (per step decision probability).
- Variable:  $n_e$  (number of observed errors).
- Result:  $n_s$  (number of expected samples for pass/fail, depending on which one is calculated).

The per step decision probability risk,  $d$ , expresses the probability of making an incorrect pass/fail decision in the current step (i.e., for the current decision coordinate).  $d$  is determined by simulation such that the overall risk of making a wrong decision over all steps of each test of a large number of tests on a large number of BSs that exactly meet the BLER limit is  $D=0.001\%$  (and hence the CL 99.999%).

It should be noted that  $d$  is determined separately considering early pass and early fail testing.

For a marginal BS (i.e., a BS almost exactly meeting the BLER), the unmodified early pass/early fail approach is unable to distinguish whether the BS has just passed or just failed the BLER ( $\epsilon \rightarrow 0$ ), and can thus terminate with an "undecided" result. To avoid this undecided result and provide selectivity, a so-called "bad device factor" ( $M$ ) is introduced into the early pass calculation. This factor biases the decision towards avoiding failing good BS.

#### M.1.3.2 Simulation to derive the pass-fail limits for testing PUSCH 0.001% BLER

There is freedom to design the decision co-ordinates ( $n_e$ ,  $n_s$ ), as captured in clause M.1.2.

The binomial distribution and its inverse are used to design the pass and fail limits. Note that this method is not unique and that other methods exist.

$$\text{fail}(ne, d_f) := \frac{ne}{ns_f} = \frac{ne}{(ne + qnbinom(d_f, ne, ER))}$$

$$\text{pass}(ne, cl_p, M) := \frac{ne}{ns_p} = \frac{ne}{(ne + qnbinom(cl_p, ne, ER \cdot M))}$$

Where

- fail(..) is the error ratio for the fail limit.
- pass(..) is the error ratio for the pass limit.
- ER is the specified error ratio 1e-5.
- ne is the number of bad results. This is the variable in both equations.
- M is the Bad EUT factor M=1.5.
- d<sub>f</sub> is the wrong decision probability of a single (ne, ns) co-ordinate for the fail limit. It is found by simulation to be d<sub>f</sub> = 2e-7.
- cl<sub>p</sub> is the confidence level of a single (ne, ns) co-ordinate for the pass limit. It is found by simulation to be cl<sub>p</sub> = 0.9999999.
- qnbinom(..): The inverse cumulative function of the negative binomial distribution.

The simulation works as follows:

- A large population of limit EUTs with true ER = 1e-5 is decided against the pass and fail limits.
- cl<sub>p</sub> and d<sub>f</sub> are tuned such that CL (99.999 %) of the population passes and D (0.001 %) of the population fails.
- A population of Bad EUTs with true ER = M\*1e-5 is decided against the same pass and fail limits.
- cl<sub>p</sub> and d<sub>f</sub> are tuned such that CL (99.999 %) of the population fails and D (0.001 %) of the population passes.
- The number of EUTs decrease during the simulation, as the decided EUTs leave the population. That number decreases with an approximately exponential characteristics. After 642 bad results all EUTs of the population are decided.

NOTE: The exponential decrease of the population is an optimal design goal for the decision co-ordinates (ne, ns), which can be achieved with other formulas or methods as well.

## Annex N (informative): Change history

Change history							
Date	Meeting	TDoc	CR	Rev	Cat	Subject/Comment	New version
2017-11	RAN4#84bis	R4-1711983	-	-	-	TS skeleton	0.0.1
2018-04	RAN4#86bis	R4-1805875, R4-1805876, R4-1804931, R4-1805877, R4-1805386, R4-1805916, R4-1805915, R4-1805878	-	-	-	Implementation of TPs agreed during RAN4#86bis, on top of the agreed R4-1803913: - R4-1805875 TP for TS 38.141-2: Addition of applicability table in clause 4.7.2 - R4-1805876 TP for TS 38.141-2: Addition of co-location reference antenna description to clause 4.13 - R4-1804931 TP to TS 38.141-2: clauses 1-3 - R4-1805877 TP to TS 38.141-2: clauses 4, 5 - R4-1805386 TP to TS 38.141-2: clause 6 - R4-1805916 TP to TS 38.141-2: clause 7 - R4-1805915 TP to TS 38.141-2: NR BS OTA sensitivity conformance test (7.2) - R4-1805878 TP to TS 38.141-2: NR BS OTA REFSENS conformance test (7.3)	0.1.0
2018-06	RAN4#87	R4-1714157, R4-1806599, R4-1807591, R4-1807747, R4-1808325, R4-1808329, R4-1808331, R4-1808332, R4-1808333, R4-1808334, R4-1808336, R4-1808337, R4-1808483, R4-1808487	-	-	-	Implementation of TPs agreed during RAN4#87, on top of R4-1807255: - R4-1714157 TP to TS 38.141-2 - annex with spatial declarations definitions - R4-1806599 TP to TS 38.141-2: NR BS OTA dynamic range conformance test (7.4) - R4-1807591 TP to TS 38.141-2 - update to Rx general clause (7.1) - R4-1807747 TP to TS 38.141-2: Annexes - R4-1808325 TP to TS 38.141-2: Improvement of RIB interface in Figures 4.2-1, 4.2-2 and 4.2-3, in clause 4.2 - R4-1808329 TP to TS 38.141-2: NR BS OTA in-band selectivity and blocking conformance test (7.5) - R4-1808331 TP to TS 38.141-2: Definitions, symbols and abbreviations (Clauses 3) - R4-1808332 TP to TS 38.141-2: NR BS OTA occupied bandwidth (6.7.2) - R4-1808333 TP to TR 38.141-2: Clarifications on OTA sensitivity requirement (7.2.1, 7.3.1) - R4-1808334 TP to TS 38.141-2 - OTA base station output power (6.3) - R4-1808336 TP to TS 38.141-2 - OTA in-band receiver intermodulation (7.8) - R4-1808337 TP to TS 38.141-2 - OTA in-channel selectivity (7.9) - R4-1808483 TP to TS 38.141-2: multi-band operation - R4-1808487 TP to TS 38.141-2 - OTA output power dynamics (6.4)	0.2.0

2018-07	RAN4-AH-1807	<p>R4-1808823</p> <p>R4-1808874</p> <p>R4-1809109</p> <p>R4-1809465</p> <p>R4-1809485</p> <p>R4-1809486</p> <p>R4-1809487</p> <p>R4-1809488</p> <p>R4-1809489</p> <p>R4-1809490</p> <p>R4-1809491</p> <p>R4-1809493</p> <p>R4-1809494</p> <p>R4-1809495</p> <p>R4-1809496</p> <p>R4-1809497</p> <p>R4-1809499</p> <p>R4-1809501</p> <p>R4-1809516</p> <p>R4-1809561</p> <p>R4-1809562</p>	-	-	-	<p>Implementation of TPs approved during RAN4-AH-1807, on top of R4-1809266 (TS 38.141-2, v0.2.0):</p> <ul style="list-style-type: none"> <li>- R4-1808823 TP to TS 38.141-2: Applicability of requirements (Clauses 4.7)</li> <li>- R4-1808874 TP to TS 38.141-2: Introduction of the transmit, receive and co-location configurations, in clause 4.5</li> <li>- R4-1809109 TP to TS 38.141-2 - Annex D, TX and RX Test setup</li> <li>- R4-1809465 TP to TS 38 141-2 - 4.8.2 Test signal Configurations</li> <li>- R4-1809485 TP to TS 38.141-2: NR BS acceptable uncertainty of OTA Test System (4.1.2)</li> <li>- R4-1809486 TP to TS 38.141-2: NR BS derivation of test requirement (Annex C)</li> <li>- R4-1809487 TP to TS 38.141-2: Correction of RX procedures</li> <li>- R4-1809488 TP to TS 38.141-2: Correction of TX directional power related requirements</li> <li>- R4-1809489 TP to TS 38.141-2 – OTA unwanted emissions – General (6.7.1)</li> <li>- R4-1809490 TP to TS 38.141-2: NR BS OTA occupied bandwidth (6.7.2)</li> <li>- R4-1809491 TP to TS 38.141-2 – OTA ACLR (6.7.3)</li> <li>- R4-1809493 TP to TS 38.141-2 Annex XX - measuring extreme conditions</li> <li>- R4-1809494 TP to TS 38 141-2 Test requirement for Radiated transmit power</li> <li>- R4-1809495 TP to TS 38.141-2 Transmitter spurious emissions (6.7.5)</li> <li>- R4-1809496 TP to TS 38.141-2: Adding requirement text for OTA Tx IMD in clause 6.8 and Annex E1.7</li> <li>- R4-1809497 TP to TS 38.141-2 Receiver spurious emissions (7.7)</li> <li>- R4-1809499 TP to TS38.141-2: OTA frequency error (6.6.2)</li> <li>- R4-1809501 TP to TS38.141-2: OTA time alignment error (6.6.4)</li> <li>- R4-1809516 TP to TR 38.141-2: NR BS OTA manufacturers declarations for radiated test requirements (4.6)</li> <li>- R4-1809561 TP to TS38.141-2: OTA modulation quality (6.6.3)</li> <li>- R4-1809562 TP to TS 38.141-2 – OTA operating band unwanted emissions (6.7.4)</li> </ul>	0.3.0
---------	--------------	---	---	---	---	---	-------

2018-08	RAN4#8	R4-1810818, R4-1810822, R4-1810823, R4-1811150, R4-1811538, R4-1811592, R4-1811618, R4-1811621, R4-1811626, R4-1811742, R4-1811743, R4-1811745, R4-1811746, R4-1811747, R4-1811748, R4-1811749, R4-1811750, R4-1811751, R4-1811752, R4-1811754, R4-1811760, R4-1811766, R4-1811767, R4-1811848, R4-1811879, R4-1811886, R4-1811887	-	-	-	Implementation of TPs approved during RAN4#88, on top of R4-1810576 (TS 38.141-2, v0.3.0): - R4-1810818 TP to TS 38.141-2: Operating bands and channel arrangement (5) - R4-1810822 TP to TS 38.141-2: initial conditions for FR2 Rx spur test (7.7) - R4-1810823 TP to TS 38.141-2: FRC annex (A) - R4-1811150 TP: Add parameters band n50 in TS 38.141-2 - R4-1811538 TP for introduction of band n74 for TS38.141-2 - R4-1811592 TP to TS38.141-2: OTA operating band unwanted emissions requirements (6.7.4) - R4-1811618 Correction on general clause for 38.141-2 - R4-1811621 TP to TS 38.141-2 Clause 4.8.2.1 Test signal used to build Test Configurations - R4-1811626 TP to TS 38.141-2: Clause 6.1 NR Test Models - R4-1811742 TP to TS38.141-2: Regional requirements (4.4) - R4-1811743 TP to TS 38.141-2: Remaining issues and corrections for Radiated Tx power (EIRP) (6.2) - R4-1811745 TP to TS 38.141-2: Corrections and improvements to the OTA Tx spurious emissions test (6.7.5) - R4-1811746 TP to TS 38.141-2: Calibration annex (D) - R4-1811747 TP to TS 38.141-2: Improvements of co-location requirement description in clause 4.12 - R4-1811748 TP to TS 38.141-2: NR BS OTA occupied bandwidth (6.7.2) - R4-1811749 TP to TS 38.141-2: Adding requirement text for OTA co-location spurious emission in clause 6.7.5 and Annex E1.3 - R4-1811750 TP to TS 38.141-2 on MU and TT for Rx requirements for FR1 and FR2 - R4-1811751 TP to TS 38.141-2 on MU and TT for transmission in-band TRP emission and directional requirements or FR2 and FR1 - R4-1811752 TP to TS38.141-2 on MU and TT for extreme EIRP for FR1 and FR2 - R4-1811754 TP to TS 38.141-2: Improvement of requirement text for OTA TX IMD in clause 6.8 and Annex E.1.5 - R4-1811760 TP to TS 38.141-2: test tolerance table (Annex C) - R4-1811766 TP to TS 38.141-2: wideband operation corrections and FBW declarations (4.6) - R4-1811767 TP to TS 38.141-2: OTA declarations cleanup (4.6) - R4-1811848 TP to TS 38.141-2: Adding requirement text for OTA out-of-band blocking in clause 7.6 and Annex E2.4.1 and E2.4.2 - R4-1811879 TP to TS 38.141-2 – Overview of radiated Tx and Rx requirements (4.13) - R4-1811886 TP to TS 38.141-2: OBUE correction - R4-1811887 TP to TS 38.141-2 on OTA Tx ON/OFF power requirements	0.4.0
2018-09	RAN#81	RP-181664	-	-	-	Presented to TSG RAN for information.	1.0.0



2018-11	RAN4#8 8bis	R4-1812584, R4-1812666, R4-1812683, R4-1813300, R4-1813301, R4-1813310, R4-1813532, R4-1813754, R4-1813877, R4-1813881, R4-1813883, R4-1813896, R4-1813899, R4-1813900, R4-1813901, R4-1813902, R4-1813903, R4-1813907, R4-1813908, R4-1813911, R4-1813912, R4-1813913, R4-1813914, R4-1813915, R4-1813993, R4-1814074, R4-1814078, R4-1814080, R4-1814120, R4-1814193, R4-1814250, R4-1814251, R4-1814253, R4-1814254	-	-	-	<p>Implementation of TPs approved during RAN4#88bis, on top of RP-181664 (TS 38.141-1, v1.0.0):</p> <ul style="list-style-type: none"> <li>- R4-1812584 TP to TS 38.141-2: Correction on NOTE for wanted signal mean power for NR BS RX requirements</li> <li>- R4-1812666 TP to TS 38.141-2: Correction of directions for OTA requirements</li> <li>- R4-1812683 TP to TS 38.141-2: Clarification Note on non-zero Test Tolerance</li> <li>- R4-1813300 TP to TS 38.141-2: correction of the OSDD definition for single RAT NR BS specification</li> <li>- R4-1813301 TP to TS 38.141-2: alignment with TS 38.104 modifications after RAN4#88</li> <li>- R4-1813310 TP to TS 38.141-2: structure alignments with TS 38.141-1</li> <li>- R4-1813532 TP to TS 38.141-2: Corrections to Modulation quality test in Clause 6.6.3</li> <li>- R4-1813754 TP to TS 38.141-2: Radiated performance requirements (8)</li> <li>- R4-1813877 TP for TS38.141-2: RF channel for BS OTA conformance test</li> <li>- R4-1813881 TP to TS 38.141-2: Clause 4.9.2.3 Data content of PHY channels</li> <li>- R4-1813883 TP to TS 38.141-2: FR2 test model(Claue 4.9.3)</li> <li>- R4-1813896 TP to TS 38.141-2: Addition of MU for OTA performance requirements for FR1</li> <li>- R4-1813899 TP to TS 38.141-2: alignment of directions to be tested for OTA requirements</li> <li>- R4-1813900 TP to TS 38.141-2 on CLTA definition</li> <li>- R4-1813901 TP to TS 38.141-2 on MU and TT corrections for FR1 and FR2</li> <li>- R4-1813902 TP to TS 38.141-2 on Rx requirement corrections for FR1 and FR2</li> <li>- R4-1813903 TP to 38.141-2: Clause 4.6 - correction for manufacturer declaration</li> <li>- R4-1813907 TP to TS 38.141-2: frequency range for the inband blocking requirement for FR2</li> <li>- R4-1813908 TP to TS 38.141-2 – adding TRP measurement grids to the annex</li> <li>- R4-1813911 TP to TS 38.141-2: Update for NR BS occupied bandwidth requirement (6.7.2)</li> <li>- R4-1813912 TP to 38.141-2: Corrections to OTA co-location spurious emission (6.7.5 and E.1.3)</li> <li>- R4-1813913 TP to 38.141-2: Corrections to OTA transmitter intermodulation in clause 6.8 and Annex E.1.5</li> <li>- R4-1813914 TP to TS 38.141-2: Correction of the RX intermodulation interferer</li> <li>- R4-1813915 TP to TS 38.141-2: In-channel selectivity (7.9)</li> <li>- R4-1813993 TP to TS 38.141-2: Radiated performance requirements for CP-OFDM based PUSCH</li> <li>- R4-1814074 TP to TS 38.141-2: Corrections on OTA transmit ON/OFF power</li> <li>- R4-1814078 TP to TS38.141-2: OTA CA CLR absolute limits (6.7.3)</li> <li>- R4-1814080 TP to TS 38.141-2: OTA declarations numbering and cross-referencing</li> <li>- R4-1814120 TP to TS 38.141-2: Correction on the FRCs in Annex A1 and A2</li> <li>- R4-1814193 TP to TS38.141-2: OTA UEM(Claue 6.7.4)</li> <li>- R4-1814250 TP to TS 38.141-2: operating bands applicable for spurious emissions testing above 12.75 GHz</li> <li>- R4-1814251 TP to TS 38.141-2: correction for the narrowest supported CHBW and SCS</li> <li>- R4-1814253 TP to TS 38.141-2: Improvement of out-of-band blocking requirement in clause 7.6</li> <li>- R4-1814254 TP to TS 38.141-2 on CLTA related MU</li> </ul>	1.1.0
---------	----------------	---	---	---	---	---	-------

2018-11	RAN4#89	R4-1816288 R4-1814444 R4-1814504 R4-1814622 R4-1815005 R4-1815268 R4-1815304 R4-1815305 R4-1815330 R4-1815375 R4-1815381 R4-1815686 R4-1815689 R4-1815963 R4-1816277 R4-1816290 R4-1816291 R4-1816292 R4-1816293 R4-1816294 R4-1816295 R4-1816296 R4-1816297 R4-1816298 R4-1816300 R4-1816305 R4-1816306 R4-1816309 R4-1816312 R4-1816313 R4-1816315 R4-1816317 R4-1816318 R4-1816319	-	-	-	Implementation of TPs approved during RAN4#89, on top of R4-1815277 (TS 38.141-1, v1.1.0): R4-1816288 TP to TS 38.141-2: general cleanup R4-1814444 TP to TS 38.141-2: FRC definitions for PUSCH and test parameters for PRACH R4-1814504 TP to TS38.141-2: Removal of the multi-band test for BS type 2-O R4-1814622 TP to TS 38.141-2 on Characteristics of the interfering signals R4-1815005 TP to 38.141-2: MU clarifications R4-1815268 TP to TS 38.141-2 on General radiated receiver characteristics R4-1815304 TP to TS 38.141-2: Alignment of test procedure for OTA out-of-band blocking in clause 7.6 R4-1815305 TP to TS 38.141-2: Improvement of test specification text with respect to directions for OTA out-of-band blocking in clause 7.6 R4-1815330 TP to TS 38.141-2: Correction to FBW definition in clause 3.1 R4-1815375 TP to TS 38.141-2: Interpretation of measurement results and the Shared Risk principle R4-1815381 TP to 38.141-2: OTA demodulation alignment with TS38.104 (8.1) R4-1815686 TP to 38.141-2: alignment of OTA requirement names R4-1815689 TP to 38.141-2: OTA out-of-band blocking co-location requirement (7.6) R4-1815963 TP to TS 38.141-2: corrections of notes in declarations table (4.6) R4-1816277 TP to TS 38.141-2: remaining annexes R4-1816290 TP to TS 38.141-2 on manufacturer declarations for NR radiated requirements testing R4-1816291 TP to TS 38.141-2: narrowest beam selection for OTA testing R4-1816292 TP to 38.141-2: Radiated transmit power testing extreme environment conditions (6.2) R4-1816293 TP to TS38.141-2: Radiated transmit power requirement with wideband operation (6.2) R4-1816294 TP to TS38.141-2: OTA total power dynamic range(Clause 6.4.3) R4-1816295 TP to TS 38.141-2: OTA transmitter OFF power (Clause 6.5.1) R4-1816296 TP to TS38.141-2: OTA ACLR, UEM and spurious emission (Clause 6.7.3) R4-1816297 TP to TS 38.141-2: additional spurious emissions requirement corrections (6.7.5.4.5.1) R4-1816298 TP to TS 38.141-2: Correction to RX receiver test directions R4-1816300 TP to TS 38.141-2 – adding further details on reference steps to the annex R4-1816305 TP to TS 38.141-2 - polarization wording improvements for OTA sensitivity and reference sensitivity R4-1816306 TP to TS 38.141-2 Corrections on transmitter intermodulation (clause 3.2 and 6.8) R4-1816309 TP to TS 38.141-2 - update FR2 extreme MU and TT R4-1816312 TP to TS 38.141-2: Addition of calibration procedure for extreme temperature testing in Annex B.7 R4-1816313 TP to TS 38.141-2: Test distance for blocking interferer signal in clause 7.6 R4-1816315 TP to 38.141-2: Corrections to co-location requirements R4-1816317 TP to 38.141-2 Corrections to TRP grids formula in Annex I and adding reference in Clause 6.5 R4-1816318 Operating band orthogonal cuts measurement R4-1816319 TP to TS 38.141-2 Correction on declaration R4-1816350 TP for introducing propagation conditions in TS 38.141-2	1.2.0
---------	---------	--	---	---	---	---	-------

		R4-1816350 R4-1816353 R4-1816356 R4-1816359 R4-1816361 R4-1816362 R4-1816371 R4-1816446 R4-1816484 R4-1816485 R4-1816593 R4-1816720 R4-1816726 R4-1816732 R4-1816735 R4-1816740			R4-1816353 TP to TS 38.141-2: Radiated test requirements for DFT-s-OFDM based PUSCH R4-1816356 TP for TS 38.141-2 on NR PUCCH format2 radiated performance requirements R4-1816359 TP to TS38.141-2: Performance requirements for PRACH R4-1816361 TP for TS38.141-2: PUCCH format 1 OTA conformance test R4-1816362 TP to TS 38.141-2: Radiated test requirements for CP-OFDM based PUSCH in FR1 R4-1816371 TP to 38.141-2 – PUSCH requirements with CP-OFDM for FR2 R4-1816446 TP to TS 38.141-2: Cleanup to OTA requirements text R4-1816484 TP to TS 38.141-2: Improvement of specification text related to injection of interferer power for OTA TX IMD in clause 6.8 R4-1816485 TP on 38.141-2: Deletion of test procedure on OFF power and transient period for FR2 R4-1816593 TP to TS 38.141-2: PUCCH format 0 requirement testing R4-1816720 TP for introducing PUCCH format 3 and 4 radiated conformance requirements for OTA test in 38.141-2 R4-1816726 TP to TS 38.141-2: FR2 test model(Claue 4.9.2) R4-1816732 TP to TS 38.141-2: OTA transmitted signal quality (Clause 6.6) R4-1816735 TP to TS 38.141-2: Clause 4.9.2.3 Data content for PHY channels R4-1816740 TP to TS 38.141-2: Correction to FR2 OTA REFSENS requirement	
2018-12	RAN#82	RP-182584			Presented to TSG RAN for approval.	2.0.0
2018-12	RAN#82				Approved by plenary – Rel-15 spec under change control	15.0.0

2019-03	RAN#83	RP-190403	0001		B	<p>CR to TS 38.141-2</p> <p>Implementation of the following draft CRs, which were Endorsed during RAN4#90, on top of v15.0.0:</p> <p>R4-1900286 Draft CR on NR PUCCH format2 radiated performance requirements for TS 38.141-2</p> <p>R4-1900629 Draft CR to TS 38.141-2_Clean up the test requirements for some Rx requirements</p> <p>R4-1900739 Draft CR to TS 38.141-2:OTA dynamic range test requirement (7.4.5)</p> <p>R4-1900742 Draft CR to TS 38.141-2:Correction on OTA total power dynamic range requirement (6.4.3)</p> <p>R4-1900765 Draft CR to TS 38.141-2: Update of test requirement numbers for DFT-s-OFDM based PUSCH</p> <p>R4-1900830 Draft CR to TR 38.141-02: Correction to manufacturer declaration in clause 4.6</p> <p>R4-1900877 Draft CR to TS 38.141-2: On RX spurious emissions requirement</p> <p>R4-1900970 Draft CR for 38.141-2: Radiated test requirements for NR PUCCH format 1</p> <p>R4-1901009 Draft CR to 38.141-2: Addition of coordinates system definition</p> <p>R4-1901325 Draft CR to 38.141-2: Correction to clause 6.4.3 OTA total power dynamic range - correction</p> <p>R4-1901332 Draft CR to 38.141-2: Updates for Abbreviations clause</p> <p>R4-1901372 CR to TS 38.141-2: Clause 3.2 Missing Beam width Symbol Definition</p> <p>R4-1901389 Draft CR to TS 38.141-2 BS demodulation PUCCH format 0 requirements</p> <p>R4-1901476 Draft CR to TS 38.141-2 Corrections on transmitter co-existence and co-location requirements</p> <p>R4-1901486 Draft CR to TS 38.141-2: Corrections on OTA in-band blocking requirements</p> <p>R4-1901538 TS 38.141-2: Editorial corrections</p> <p>R4-1901743 DraftCR to TS 38.141-2: addition of the luant BS modem clause</p> <p>R4-1902261 draft CR to TS 38.141-2 - update emissions scaling</p> <p>R4-1902274 Draft CR to TS 38.141-2: Addition of missing EIRP/EIS terminology in Clause 3</p> <p>R4-1902275 Draft CR to 38.141-2; Correction to definition of OTA reference sensitivity</p> <p>R4-1902276 Draft CR to TS 38.141-2:Overview of radiated Tx requirements (4.1.1)</p> <p>R4-1902277 Draft CR to TS 38.141-2: Corrections on Measurement uncertainties and test requirements</p> <p>R4-1902278 CR to TS 38.141-2: Adding clause 4.8 reference to test procedures</p> <p>R4-1902279 Draft CR to TS 38.141-2_Correction on test procedures for single-carrier and multi-carrier operation for Tx requirements</p> <p>R4-1902281 Draft CR to 38.141-2: Cleanup of RX procedures</p> <p>R4-1902282 Draft CR to TS 38.141-2:Test tolerance for radiated transmit power (C.1)</p> <p>R4-1902283 Draft CR to TS 38.141-2_Correction on multi-band operation related requirements</p> <p>R4-1902285 Correction of FR2 RoAoA declaration</p> <p>R4-1902287 Draft CR to 38.141-2; clarification of BS power limits</p> <p>R4-1902289 Draft CR to TR 38.141-2: Editorial clean-up of TRP measurement clause in Annex I</p> <p>R4-1902291 Draft CR to 38.141-2: Addition of measurement system setup for radiated performance requirements</p> <p>R4-1902293 Draft CR for TS 38.141-2: Correction on TM applicability</p>	15.1.0
---------	--------	-----------	------	--	---	--	--------

					<p>R4-1902295 Corrections to 38.141-2 clause 4.9.2 base conformation test models</p> <p>R4-1902319 Draft CR to TS38.141-2 Tx OFF and transient measurement procedure</p> <p>R4-1902343 CR to TS 38.141-2: FR frequency limit corrections</p> <p>R4-1902385 Draft CR to TS 38.141-2: Applicability rule for BS radiated demodulation test</p> <p>R4-1902391 draftCR for TS 38.141-2: Radiated test requirements for CP-OFDM based PUSCH in FR1</p> <p>R4-1902395 Draft CR to 38.141-2 – PUSCH requirements with CP-OFDM for FR2</p> <p>R4-1902398 draftCR: Updates to PUCCH format 3 and 4 radiated conformance testing in TS 38.141-2</p> <p>R4-1902401 Draft CR for updating PRACH performance requirements in TS38.141-2</p> <p>R4-1902446 Draft CR to TS 38.141-2: Editorial CR for BS radiated demodulation test</p> <p>R4-1902573 Corrections to 38.141-2 Delay profile calculation</p> <p>R4-1902647 CR to TS 38.141-2: NR TM Multicarrier Configuration</p>	
--	--	--	--	--	--	--

2019-06	RAN#84	RP-191240	0005		B	<p>CR to TS 38.141-2: Implementation of endorsed draft CRs from RAN4#90bis and RAN4#91</p> <p>Implementation of Draft CRs into the merged Draft CR based on the endorsed tdocs during RAN4#90bis, on top of TS 38.141-2, v15.1.0:</p> <p>R4-1903326 Draft CR to TS 38.141-2: cleanup</p> <p>R4-1903331 Draft CR to TS 38.141-2: performance measure correction for the Rx requirements</p> <p>R4-1903459 Draft CR to TS 38.141-2: Correction to TX requirements with respect to total EIRP in clause 6.2.4.2, clause 6.3.4.2 and Annex B.7.1</p> <p>R4-1903490 Draft CR to 38.141-2: Addition of measurement uncertainty for FR2 performance requirements</p> <p>R4-1903615 Draft CR to 38.141-2_Correction on OTA BS output power requirements (6.3)</p> <p>R4-1903616 Draft CR to 38.141-2: Correction on OTA occupied bandwidth requirements (6.7.2)</p> <p>R4-1903617 Draft CR to 38.141-2: Correction on OTA transmitter spurious emissions requirements (6.7.5)</p> <p>R4-1904207 Editorial corrections to TS 38.141-2</p> <p>R4-1904236 draftCR: Correlation matrix for 8Rx in TS 38.141-2</p> <p>R4-1904722 Draft CR to TS 38.141-2: Update of applicability rule for BS radiated demodulation test</p> <p>R4-1904725 Draft CR to TS 38.141-2: Update of radiated test requirements for DFT-s-OFDM based PUSCH</p> <p>R4-1904728 draftCR for TS 38.141-2: Radiated test requirements for CP-OFDM based PUSCH in FR1</p> <p>R4-1904731 Draft CR on PRACH performance requirements in TS38.141-2</p> <p>R4-1904733 Draft CR on TS 38.141-2 Radiated test requirements for PUCCH format 1</p> <p>R4-1904737 Draft CR on NR PUCCH format2 radiated performance requirements for TS 38.141-2</p> <p>R4-1904738 Draft CR to TS 38.141-2 Adding required vendor declaration items for BS demodulation</p> <p>R4-1904741 Draft CR to TS 38.141-2 BS demodulation PUCCH format 0 requirements</p> <p>R4-1904744 draftCR: Measurement system set-up and TT in TS 38.141-2</p> <p>R4-1904747 draftCR: Updates to PUCCH format 3 and 4 radiated conformance testing in TS 38.141-2</p> <p>R4-1904803 Draft CR to TS 38.141-2: FRC update for PUSCH FR1 mapping type B and FR2 DMRS 1+1</p> <p>R4-1904818 Draft CR: Clarification on step 5 and step 6 for delay profiles calculation (38.141-2)</p> <p>R4-1904843 Draft CR to TS 38.141-2 BS demodulation CP-OFDM PUSCH FR2 requirements</p> <p>R4-1905112 Draft CR to TS 38.141-2:Overview of radiated Tx requirements (4.1.1)</p> <p>R4-1905118 Corrections to TS38.141-2 clause 6.6.3.5 EVM measurement</p> <p>R4-1905119 draft CR to TS38.141-2 on clause 4.9.2.3 header</p> <p>R4-1905122 draft CR to TS38.141-2 on test model(Claue 4.9.2)</p> <p>R4-1905125 draft CR to 38.141-2 for TAE requirements</p> <p>R4-1905129 draft CR to TS38.141-2 on FR2 OFF power test procedure</p> <p>R4-1905130 draft CR to TS38.141-2 on TT and MU tables for FR2 OFF power</p> <p>R4-1905142 Draft CR: editorial correction on FR1 spurious emission requirement in TS38.141-2</p> <p>R4-1905147 Draft CR to TS 38.141-2: Clarification on application of interfering signal offsets for ACS, blocking and intermodulation requirements</p>	15.2.0
---------	--------	-----------	------	--	---	---	--------

					<p>R4-1905150 Draft CR to TS 38.141-2: Corrections on out-of-band blocking requirement</p> <p>R4-1905175 Draft CR to TS 38.141-2: FRC reference corrections for the Rx requirements</p> <p>R4-1905177 Draft CR to TS 38.141-2: consideration of supported frequency range of the operating band</p> <p>R4-1905183 Draft CR for TS 38.141-2: Improvements of figures in Annex E</p> <p>R4-1905184 Draft CR to TS 38.141-2: Correction on manufacturer's declarations related to multi-band operation(clause 4.6)</p> <p>R4-1905185 Draft CR for TS 38.141-2: Addition of NOTE for transmitter intermodulation requirements in certain regions</p> <p>R4-1905200 Draft CR to TS 38.141-2: Addition of RC test method for spurious emission in clause 6.7 and 7.7</p> <p>R4-1902647 CR to TS 38.141-2: NR TM Multicarrier Configuration</p> <p>Implementation of Draft CRs into the merged CR based on the endorsed docs during RAN4#91, on top of TS 38.141-1 in R4-1905216:</p> <p>R4-1905410 DraftCR to TS 38.141-2 Editorial Corrections</p> <p>R4-1905536 draftCR to TS 38.141-2 OTA RX spurious emission (clause 7.7)</p> <p>R4-1905901 draft CR to TS 38.141-2 - corrections to test set up diagrams</p> <p>R4-1906004 Draft CR to 38.141-2: 6.8 OTA transmitter intermodulation – correction of interfering signal type</p> <p>R4-1906120 Draft CR to TS 38.141-2 Correction on multi-band test configurations</p> <p>R4-1906313 Draft CR to 38.141-2: Correction on FRC (Annex A)</p> <p>R4-1906783 Draft CR to TS38.141-2 on FR2 MU tables correction on frequency range (4.1.2.2, 4.1.2.3)</p> <p>R4-1906920 Draft CR to TS 38.141-2: Clarification on type of interfering signal for ACS, in-band blocking and ICS requirements</p> <p>R4-1906968 Draft CR to TS 38.141-2: adding further details to spherical Fibonacci grids (I.4)</p> <p>R4-1907112 Draft CR to TS 38.141-2: correction of the fundamental frequency limit of 2.55GHz for the spurious emissions</p> <p>R4-1907245 Draft CR to TS 38.141-2: Update of applicability rule for BS radiated demodulation test</p> <p>R4-1907248 Draft CR to TS 38.141-2: Update of radiated test requirements for DFT-s-OFDM based PUSCH</p> <p>R4-1907251 Draft CR to TS 38.141-2: Correction on the terminology in PUSCH FRC tables</p> <p>R4-1907254 Draft CR to TS38.141-2: Updates of PRACH performance requirements</p> <p>R4-1907257 Draft CR on NR PUCCH format2 radiated performance requirements for TS 38.141-2</p> <p>R4-1907260 Draft CR on NR UCI on PUSCH radiated performance requirements for TS 38.141-2</p> <p>R4-1907263 draftCR: Updates to PUCCH format 3 and 4 radiated conformance testing in TS 38.141-2</p> <p>R4-1907265 Draft CR on TS 38.141-2 Radiated test requirements for PUCCH format 1</p> <p>R4-1907271 Draft CR to TS 38.141-2 Manufacturer declaration for BS demodulation</p> <p>R4-1907274 Draft CR to TS 38.141-2 BS demodulation PUCCH format 0 requirements</p> <p>R4-1907276 Draft CR to TS 38.141-2 BS demodulation CP-OFDM PUSCH FR2 requirements</p> <p>R4-1907279 draftCR for TS 38.141-2: Radiated test requirements for CP-OFDM based PUSCH in FR1</p>	
--	--	--	--	--	---	--

					<p>R4-1907631 Draft CR to 38.141-2: Term "reference signal" replacing by term "ideal signal" in EVM context</p> <p>R4-1907633 Draft CR to 38.141-2: corrections to the Annex F structure</p> <p>R4-1907637 Draft CR to TS38.141-2 on target resource block clarification for EVM measurement (4.9.2.2, 4.9.2.3, 6.6.3.5)</p> <p>R4-1907639 Draft CR to TS38.141-2: Correction on test model</p> <p>R4-1907642 Draft CR to TS38.141-2 on TT and MU tables for FR2 Tx OFF power measurement (4.1.2.2, C.1)</p> <p>R4-1907660 Draft CR to TS 38.141-2 on Spurious emission Category B in FR2</p> <p>R4-1907663 Draft CR to 38.141-2: BS TAE requirements</p> <p>R4-1907666 Draft CR to 38.141-2: Clarification of interferer RB frequency for narrowband blocking</p> <p>R4-1907670 Draft CR to TS 38.141-2: Corrections to Annex I (TRP)</p> <p>R4-1907671 Draft CR to TS 38.141-2: Correction on usage of terms TRP and EIRP</p> <p>R4-1907677 Draft CR to 38.141-2: Correction on OTA measurement setup (Annex E)</p> <p>R4-1907678 Draft CR to TS 38.141-2: Added description of symbol TRP Estimate</p> <p>R4-1907682 Draft CR to 38.141-2: Correction on procedure for general OTA transmitter spurious emissions requirements (6.7.5)</p> <p>R4-1907683 Draft CR to 38.141-2: Correction on OTA transmitter spurious emissions co-location requirements (6.7.5)</p> <p>R4-1907684 Draft CR to 38.141-2 Definition of contiguous transmission bandwidth</p> <p>R4-1907847 Draft CR to TS 38.141-02: Test model (clause 4.9.2)</p> <p>R4-1907851 Draft CR to TS 38.141-2: Editorial cleanup of OTA transmit ON/OFF power in clause 6.5</p> <p>R4-1907853 Draft CR to TS 38.141-2: Clarification om beam identifier declaration in clause 4.6</p>		
2019-06	RAN#84	RP-191242	0002		B	Introduction of band n14 - CR to TS 38.141-2	16.0.0
2019-06	RAN#84	RP-191246	0003		B	Introduction of band n30 - CR to TS 38.141-2	16.0.0
2019-06	RAN#84	RP-191250	0004	1	B	n65 introduction to 38.141-2	16.0.0
2019-09	RAN#85	RP-192029	0006	1	F	CR on Protection of SUL bands to TS 38.141-2	16.1.0
2019-09	RAN#85	RP-192034	0007	1	B	n29 introduction to 38.141-2	16.1.0
2019-09	RAN#85	RP-192022	0009		A	CR to TS 38.141-2: Implementation of endorsed draft CRs from RAN4#92 (Rel-16) - Mirrors changes in R4-1910361 for Rel-15 TS 38.141-2	16.1.0
2019-12	RAN#86	RP-193001	0011	1	A	CR to TS 38.141-2: Further update of applicability rule for BS radiated demodulation test (Rel-16)	16.2.0
2019-12	RAN#86	RP-193001	0013	1	A	CR to TS 38.141-2: Update of radiated test requirements for DFT-s-OFDM based PUSCH (Rel-16)	16.2.0
2019-12	RAN#86	RP-193013	0014		B	Introduction of 2010-2025MHz SUL band into Rel-16 TS 38.141-2	16.2.0
2019-12	RAN#86	RP-193003	0018	1	A	CR on correction of NR PUCCH format2 radiated performance requirements (Rel-16) for TS 38.141-2	16.2.0
2019-12	RAN#86	RP-193003	0020	1	A	CR on correction of NR UCI on PUSCH radiated performance requirements (Rel-16) for TS 38.141-2	16.2.0
2019-12	RAN#86	RP-193001	0022		A	CR on correction on FRC table for FR1 PUSCH radiated performance requirements (Rel-16) for TS 38.141-2	16.2.0
2019-12	RAN#86	RP-193003	0024	1	A	CR for 38.141-2: Radiated test requirements for CP-OFDM based PUSCH in FR1	16.2.0
2019-12	RAN#86	RP-192989	0027		A	CR to 38.141-2 on Receiver spurious emission requirements	16.2.0
2019-12	RAN#86	RP-192989	0031		A	CR to TS 38.141-2: Correction on interference level of receiver dynamic range requirement	16.2.0
2019-12	RAN#86	RP-192989	0033		A	CR to TS 38.141-2: Correction on interfering signal frequency offsets for receiver intermodulation requirements	16.2.0
2019-12	RAN#86	RP-192989	0035		A	CR to TS 38.141-2: Clarification of conformance testing for same beams	16.2.0



2019-12	RAN#86	RP-193001	0036		A	Updates to PRACH OTA tests in TS 38.141-2 for Rel-16	16.2.0
2019-12	RAN#86	RP-192989	0045		A	CR to TS 38.141-2 some clean up of clause 6.3.5 and 6.4.1	16.2.0
2019-12	RAN#86	RP-192989	0048		A	CR to TS38.141-2: further updates on the abbreviations (clause 3.3)-R16	16.2.0
2019-12	RAN#86	RP-192989	0050		A	CR to 38.141-2 additional updates on clarification for NR TM1.1	16.2.0
2019-12	RAN#86	RP-192990	0054		A	CR to 38.141-2: Annex L.5 Resource element TX power	16.2.0
2019-12	RAN#86	RP-193001	0056		A	CR to TS 38.141-2 BS demodulation PUCCH format 0 requirements	16.2.0
2019-12	RAN#86	RP-193001	0058		A	CR to TS 38.141-2 BS demodulation CP-OFDM PUSCH FR2 requirements	16.2.0
2019-12	RAN#86	RP-192990	0060		A	CR to TS 38.141-2: Additional information about alignment needed for TRP measurements in Annex I	16.2.0
2019-12	RAN#86	RP-192990	0065		A	CR to 38.141-2: Correction on FR2 Category B OBUE mask	16.2.0
2019-12	RAN#86	RP-192990	0067		A	CR Corrections to EVM 38.141-2 Annex L.7	16.2.0
2019-12	RAN#86	RP-192990	0069		A	CR Corrections to EVM 38.141-2 Annex L.4	16.2.0
2019-12	RAN#86	RP-192990	0071		A	CR to TS 38.141-2: correction of the multipath fading reference for BS demodulation requirements, Rel-16	16.2.0
2019-12	RAN#86	RP-192990	0075		A	CR to TS 38.141-2: Additional Tx spur for FR2 - removal, Rel-16	16.2.0
2019-12	RAN#86	RP-192990	0077		A	CR to TS 38.141-2: Calibration procedure for radiated FR2 measurements, Rel-16	16.2.0
2019-12	RAN#86	RP-193001	0079		A	CR: Removal of the square brackets for uncertainty and TT for OTA tests in 38.141-2 (Rel-16)	16.2.0
2019-12	RAN#86	RP-193001	0081		A	CR: Updates to manufacture's declarations for demodulation requirements in TS 38.141-2 (Rel-16)	16.2.0
2019-12	RAN#86	RP-193001	0083		A	CR: Updates for PUCCH format 3 and 4 radiated conformance testing in TS 38.141-2 (Rel-16)	16.2.0
2019-12	RAN#86	RP-192990	0085	1	A	Corrections of references in measurement uncertainty table	16.2.0
2019-12	RAN#86	RP-192990	0089		A	Editorial corrections	16.2.0
2019-12	RAN#86	RP-192990	0091		A	Removal of FFS and brackets in RF requirements	16.2.0
2019-12	RAN#86	RP-193003	0094		A	CR for TS 38.141-2 Radiated test requirements for NR PUCCH format 1	16.2.0
2019-12	RAN#86	RP-193003	0095		A	CR for TS 38.141-2 Radiated test requirements for NR multi-slot PUCCH	16.2.0
2019-12	RAN#86	RP-192989	0097		A	CR to TS 38.141-2: Update to Table C.1-2 FR2 OTA transmitter tests	16.2.0
2019-12	RAN#86	RP-192989	0098		A	CR to 38.141-2: OTA ACLR (6.7.3)	16.2.0
2019-12	RAN#86	RP-192989	0099		A	CR to 38.141-2: OTA receiver intermodulation procedure (7.8)	16.2.0
2019-12	RAN#86	RP-192989	0100		A	CR to 38.141-2: OTA transmitter spurious emissions (6.7)	16.2.0
2019-12	RAN#86	RP-192989	0101		A	CR to 38.141-2: OTA receiver spurious emissions (7.7)	16.2.0
2020-03	RAN#87	RP-200403	0104		A	CR on correction of NR UCI on PUSCH radiated performance requirements for TS 38.141-2	16.3.0
2020-03	RAN#87	RP-200403	0109	1	A	CR to TS 38.141-2: Corrections on rated carrier output power symbols and clarifications on procedure for reverberation chamber	16.3.0
2020-03	RAN#87	RP-200403	0111		A	CR to TS 38.141-2: Corrections on generation of test configurations	16.3.0
2020-03	RAN#87	RP-200403	0118		A	CR to TS 38.141-2: Regional requirements	16.3.0
2020-03	RAN#87	RP-200403	0120		A	IntraSlot frequency hopping applicability in the one OFDM symbol test case	16.3.0
2020-03	RAN#87	RP-200403	0128		A	CR to 38.141-2 updates for OSTP calculations	16.3.0
2020-03	RAN#87	RP-200403	0130		A	CR to 38.141-2 updates for reference to annex F and OFDM symbol TX power	16.3.0
2020-03	RAN#87	RP-200446	0143		A	CR to TS 38.141-2: Random data content for NR BS Test Models	16.3.0
2020-03	RAN#87	RP-200381	0105		B	Introduction of n26	16.3.0
2020-03	RAN#87	RP-200382	0106	1	B	Introduction of n53	16.3.0
2020-03	RAN#87	RP-200379	0116	1	C	CR for 38.141-2: new FRC tables for FR2 PUSCH 2T2R MCS12	16.3.0
2020-03	RAN#87	RP-200407	0121	1	B	Introducing of conformance tests for 350 km/h HST	16.3.0
2020-03	RAN#87	RP-200407	0122	1	B	Introduction of HST 350 km/h FRCs and channel model	16.3.0
2020-03	RAN#87	RP-200379	0132	1	C	CR for 38.141-2: Radiated test requirements for FR2 PUSCH 2T2R 16QAM	16.3.0

2020-03	RAN#87	RP-200403	0138	1	F	Corrections on receiver intermodulation	16.3.0
2020-06	RAN#88	RP-200986	0145		A	CR for 38.141-2: Radiated test requirements clarification of PUSCH BS Type O-2 PT-RS configuration for MCS 2	16.4.0
2020-06	RAN#88	RP-201043	0146		F	CR for 38.141-2: Radiated test requirements for FR2 PUSCH 2T2R 16QAM	16.4.0
2020-06	RAN#88	RP-200986	0148		A	CR to TS 38.141-2: Correction on frequency offset symbols in test configurations	16.4.0
2020-06	RAN#88	RP-200986	0150		A	CR to TS 38.141-2: Correction on test procedure of OTA in-channel selectivity	16.4.0
2020-06	RAN#88	RP-200986	0158		A	CR 38.141-2 Rel16 4.9.2.3 corrections for random data generation	16.4.0
2020-06	RAN#88	RP-200986	0162		A	CR to TS 38.141-2: Correction to out-of-band blocking requirement in clause 7.6	16.4.0
2020-06	RAN#88	RP-200972	0165		B	CR to TS 38.141-2: Introduction of FR2 DL 256QAM	16.4.0
2020-06	RAN#88	RP-200986	0168		A	CR to TS 38.141-2: MU and TT value tables	16.4.0
2020-06	RAN#88	RP-200986	0170		A	CR to TS 38.141-2: OTA receiver intermodulation interference signal type	16.4.0
2020-06	RAN#88	RP-200986	0174		A	NR FR2 test models for 16QAM	16.4.0
2020-06	RAN#88	RP-200986	0179		A	CR to TS 38.141-2: Corrections for the extreme environment testing, Rel-16	16.4.0
2020-06	RAN#88	RP-201005	0181		A	CR to TS 38.141-2: internal TR references corrections (wrt. TR 37.941 for OTA BS testing), Rel-16	16.4.0
2020-06	RAN#88	RP-200986	0183		A	CR to 38.141-2: Correction on required SNR value for multi-slot PUCCH testing (8.3.6) (C.3)	16.4.0
2020-06	RAN#88	RP-200986	0185		A	CR to TS 38.141-2 - Manufacturer declaration clarifications	16.4.0
2020-06	RAN#88	RP-200978	0190		B	CR to 38.141-2 for Introduction of band n259	16.4.0
2020-06	RAN#88	RP-200986	0192		A	CR to TS 38.141-2: Adding spherical angle definitions to 3.2	16.4.0
2020-06	RAN#88	RP-200986	0194		A	CR to TS 38.141-2: Correcting the reference angular step equations (Annex I.2.2)	16.4.0
2020-06	RAN#88	RP-200986	0198		A	CR to 38.141-2 on EESS protection for bands n257 and n258 (Rel-16)	16.4.0
2020-06	RAN#88	RP-200975	0159	1	B	Introduction of conformance tests for 350kph and 500kph HST	16.4.0
2020-06	RAN#88	RP-200975	0160	1	B	HST PUSCH demodulation FRC and channel condition annex	16.4.0
2020-06	RAN#88	RP-200975	0166	1	F	CR for 38.141-2 Introduction of PRACH radiated conformance testing for NR HST	16.4.0
2020-06	RAN#88	RP-200975	0152	1	B	CR for TS 38.141-2: introduction of NR PUSCH UL timing adjustment	16.4.0
2020-06	RAN#88	RP-200975	0153	1	B	CR for TS 38.141-2: appendix for NR PUSCH UL timing adjustment	16.4.0
2020-06	RAN#88	RP-201043	0151	1	B	CR for TS 38.141-2: Introduce PUSCH performance requirements at 30% throughput test point	16.4.0
2020-06	RAN#88	RP-200975	0154	2	B	CR for TS 38.141-2, Introduction of high speed support declaration for NR HST	16.4.0
2020-09	RAN#89	RP-201497	0203		B	CR for TS 38.141-2: Introduction of NR PUSCH UL timing adjustment performance requirement for scenario Z	16.5.0
2020-09	RAN#89	RP-201497	0205		F	CR for TS 38.141-2: Add maximum test system uncertainty for NR HST PUSCH with single port and AWGN	16.5.0
2020-09	RAN#89	RP-201497	0206	1	B	CR for TS 38.141-2, Introduction of high speed support declaration for NR HST	16.5.0
2020-09	RAN#89	RP-201512	0210		A	Clarification CR on NR-FR2-TM3.1	16.5.0
2020-09	RAN#89	RP-201512	0212		A	CR for TS 38.141-2: NR FR2 test model 2	16.5.0
2020-09	RAN#89	RP-201512	0214	1	A	CR to TS 38.141-2: Additional requirements for EESS protection (rel-16)	16.5.0
2020-09	RAN#89	RP-201512	0216		A	Increase of step size for FR2 in-band blocking conformance test	16.5.0
2020-09	RAN#89	RP-201497	0218	1	F	CR for TS 38.141-2: Introduction of test tolerance for NR HST PRACH	16.5.0
2020-09	RAN#89	RP-201512	0220	1	A	CR to 38.141-2: Annex L clarification on equalisation calculation (L.6)	16.5.0
2020-12	RAN#90	RP-202422	0228	1	F	CR for 38.141-2: Introduction of NR PUSCH UL timing adjustment performance requirement for scenario X	16.6.0
2020-12	RAN#90	RP-202489	0230		A	CR for 38.141-2: Add error-free feedback in demodulation requirement test setup	16.6.0

2020-12	RAN#90	RP-202415	0231	1	B	CR to TS 38.141-2: BS demodulation requirements for 2-step RACH (Annex)	16.6.0
2020-12	RAN#90	RP-202416	0234	1	B	Introduction of URLLC 0.001% BLER requirement	16.6.0
2020-12	RAN#90	RP-202416	0235	1	B	CR for 38.141-2: URLLC testing methodology appendix	16.6.0
2020-12	RAN#90	RP-202416	0239	1	B	CR to TS 38.141-2: Addition of BS conformance testing for FR2 URLLC PUSCH repetition Type A	16.6.0
2020-12	RAN#90	RP-202416	0240	1	B	CR to TS 38.141-2: FRC for FR1 URLLC BS performance requirements	16.6.0
2020-12	RAN#90	RP-202422	0245	1	B	Additional test cases and FRC tables for HST PUSCH	16.6.0
2020-12	RAN#90	RP-202416	0246	1	B	CR on FR2 requirements for PUSCH mapping Type B with low number of symbols	16.6.0
2020-12	RAN#90	RP-202437	0251		F	CR to 38.141-2: Correction to test system uncertainty	16.6.0
2020-12	RAN#90	RP-202489	0255		A	CR to 38.141-2 on Category B OTA spurious emissions for Band n257	16.6.0
2020-12	RAN#90	RP-202422	0256	1	B	CR for 38.141-2 Introduction of conformance testing for NR HST PRACH under fading channel	16.6.0
2020-12	RAN#90	RP-202509	0257		F	CR to 38.141-2: Annex C correction on frequency range of FR2 TT table (C.2)	16.6.0
2020-12	RAN#90	RP-202415	0258		B	CR on MsgA PUSCH radiated performance requirement for TS 38.141-2	16.6.0
2020-12	RAN#90	RP-202451	0223		B	Introduction of 1880-1920MHz SUL band into Rel-17 TS 38.141-2	17.0.0
2020-12	RAN#90	RP-202452	0225		B	Introduction of 2300-2400MHz SUL band into Rel-17 TS 38.141-2	17.0.0
2020-12	RAN#90	RP-202448	0241		B	CR to TS 38.141-2: introduction of NR band n13	17.0.0
2021-03	RAN#91	RP-210097	0259		B	CR for 38.141-2 introduction of NR band n24	17.1.0
2021-03	RAN#91	RP-210096	0260		B	CR to 38.141-2 on introducing new SUL band n99	17.1.0
2021-03	RAN#91	RP-210116	0265		A	CR for TS 38.142-2: Correction on definition for the out-of-band CLTA (Rel-17)	17.1.0
2021-03	RAN#91	RP-210116	0268		A	CR for 38.141-2: BS demodulation different channel bandwidths applicability rules	17.1.0
2021-03	RAN#91	RP-210068	0270		A	CR on FRC for URLLC BS radiated performance requirement for TS 38.141-2	17.1.0
2021-03	RAN#91	RP-210073	0272		A	CR on MsgA PUSCH radiated performance requirement for TS 38.141-2	17.1.0
2021-03	RAN#91	RP-210078	0274	1	A	Finalize SNR values for HST PUSCH	17.1.0
2021-03	RAN#91	RP-210068	0276		A	CR for TS 38.141-2: Updates of performance requirements of PUSCH repetition type A and PUSCH mapping type B for URLLC for FR1	17.1.0
2021-03	RAN#91	RP-210116	0279		A	CR to TS 38.141-2: Additions of regional requirements for n41 and n90 in Japan, Rel-17	17.1.0
2021-03	RAN#91	RP-210068	0281		A	CR on FR2 requirements for PUSCH mapping Type B with low number of symbols (Rel-17)	17.1.0
2021-03	RAN#91	RP-210073	0283		A	CR on update applicability rule for 2-step RACH in 38.141-2 (Rel-17)	17.1.0
2021-03	RAN#91	RP-210078	0285		A	CR for 38.141-2 Cleanup of conformance testing for NR HST PRACH under fading channel (Rel-17)	17.1.0
2021-03	RAN#91	RP-210068	0287		A	CR to TS38.141-2 Correction of BS conformance testing for FR2 URLLC PUSCH repetition Type A (Rel-17)	17.1.0
2021-03	RAN#91	RP-210116	0295		A	CR to TS 38.141-2 clarification on PN23 sequence generation	17.1.0
2021-03	RAN#91	RP-210116	0298		A	CR to TS 38.141-2: EESS protection requirement correction	17.1.0
2021-03	RAN#91	RP-210116	0301		A	CR to TS 38.141-2: Receiver requirement corrections	17.1.0
2021-03	RAN#91	RP-210068	0303		A	CR to TS 38.141-2 Update of 0.001% BLER test requirements	17.1.0
2021-03	RAN#91	RP-210116	0314		A	CR for 38.141-2: BS demodulation synchronization in test setup	17.1.0
2021-06	RAN#92	RP-211104	0318		A	CR for TS 38.141-2: Introduction of NR PUSCH UL TA performance requirement(Rel-17)	17.2.0
2021-06	RAN#92	RP-211094	0320		A	Big CR for NR-U BS radiated conformance testing in TS 38.141-2	17.2.0
2021-06	RAN#92	RP-211105	0322		A	CR for TS38.141-2 remove SNR brackets for HST PUSCH demodulation (catA)	17.2.0
2021-06	RAN#92	RP-211105	0326		A	CR for TS 38.141-2 Updates of performance requirements of PUSCH repetition type A for URLLC	17.2.0
2021-06	RAN#92	RP-211116	0327	1	B	CR to TS 38.141-2: Introduction of band n67	17.2.0

2021-06	RAN#92	RP-211116	0328	1	B	CR to TS 38.141-2: Introduction of band n85	17.2.0
2021-06	RAN#92	RP-211108	0336		A	CR for 38.141-2: HST demodulation specification maintenance	17.2.0
2021-06	RAN#92	RP-211109	0338		A	CR for 38.141-2: Demodulation performance enhancement specification maintenance	17.2.0
2021-06	RAN#92	RP-211094	0345		A	TS 38.141-2: Introduction of NR-U co-existence requirements	17.2.0
2021-06	RAN#92	RP-211089	0348		A	TS 38.141-2: Correction of additional spurious emission limits for bands 50, 51, 75, 76	17.2.0
2021-06	RAN#92	RP-211090	0351		A	CR to 38.141-2: removal of outstanding TBDs, Rel-17	17.2.0
2021-06	RAN#92	RP-211090	0354		A	CR to 38.141-2: In-band blocking for multi-band Base Stations	17.2.0
2021-06	RAN#92	RP-211091	0355		A	CR to 38.141-2: BS conformance test, FR2 Rx OOB test MU value correction (4.1.2.3)	17.2.0
2021-06	RAN#92	RP-211082	0359		A	CR to TS 38.141-2: Receiver IMD requirement corrections	17.2.0
2021-06	RAN#92	RP-211083	0362		A	CR for 38.141-2: Add AWGN Offset notes to FR1 and FR2 demod noise levels	17.2.0
2021-09	RAN#93	RP-211909	0365		B	CR to TS 38.141-2: Introduction of 35MHz and 45MHz	17.3.0
2021-09	RAN#93	RP-211898	0368		B	CR to 38.141-2: Introduction of n262	17.3.0
2021-09	RAN#93	RP-211926	0371		A	Big CR for TS 38.141-2 Maintenance RF part (Rel-17, CAT A)	17.3.0
2021-09	RAN#93	RP-211926	0374		A	Big CR for TS 38.141-2 Maintenance Demod part (Rel-17, CAT A)	17.3.0
2021-12	RAN#94	RP-212850	0376		A	Big CR for TS 38.141-2 Maintenance Demod part (Rel-17, CAT A)	17.4.0
2021-12	RAN#94	RP-212856	0379		A	Big CR for TS 38.141-2 Maintenance RF part (Rel-17, CAT A)	17.4.0
2022-03	RAN#95	RP-220347	0384	1	B	CR to TS 38.141-2: implementation of LTE_upper_700MHz_A band 103	17.5.0
2022-03	RAN#95	RP-220357	0385		B	CR to TS 38.141-2 the introduction of EU unlicensed band n102	17.5.0
2022-03	RAN#95	RP-220361	0386		B	Big CR for TS38.141-2 FR1 PUSCH 256QAM	17.5.0
2022-03	RAN#95	RP-220337	0389		A	Big CR for TS 38.141-2 Maintenance RF part (Rel-17, CAT A)	17.5.0
2022-03	RAN#95	RP-220337	0392		A	Big CR for TS 38.141-2 Maintenance Demod part (Rel-17, CAT A)	17.5.0
2022-03	RAN#95	RP-220376	0393		B	CR to TS 38.141-2: RMR 1900MHz band n101 introduction	17.5.0
2022-06	RAN#96	RP-221660	0398	1	F	CR to 38.141-2: BS FR2 OBUE Cat B requirement table note clarification (6.7.4.5.2)	17.6.0
2022-06	RAN#96	RP-221684	0400		B	CR to TS 38.141-2: RMR 900MHz band introduction	17.6.0
2022-06	RAN#96	RP-221680	0403		B	Big CR to TS 38.141-2 on HST FR2 BS Demodulation Performance Requirements	17.6.0
2022-06	RAN#96	RP-221660	0406		F	Big CR for TS 38.141-2 Maintenance RF part (Rel-17, CAT F)	17.6.0
2022-09	RAN#97	RP-222037	0407	1	B	CR to TS 38.141-2 - Introduction of licensed 6GHz band n104	17.7.0
2022-09	RAN#97	RP-222034	0408	1	B	CR to TS 38.141-2: Introduction of 1024 QAM in FR1	17.7.0
2022-09	RAN#97	RP-222041	0419		F	Big CR on FR2 HST BS demodulation requirement for TS 38.141-2	17.7.0
2022-09	RAN#97	RP-222026	0422		F	Big CR for TS 38.141-2 Maintenance RF part (Rel-17, CAT F) NOTE: This CR is partially implemented for NR band n46	17.7.0
2022-09	RAN#97	RP-222026	0425		F	Big CR for TS 38.141-2 Maintenance Demod part (Rel-17, CAT F)	17.7.0
2022-12	RAN#98-e	RP-223309	0427	1	F	CR to 38.141-2: Spurious emission requirements, Rel-17	17.8.0
2022-12	RAN#98-e	RP-223302	0429		B	Big CR for TS 38.141-2 Demodulation requirements for Enhanced IIoT and URLLC support	17.8.0
2022-12	RAN#98-e	RP-223293	0432		A	CR to 38.141-2: Additional BS conformance to other standards	17.8.0
2022-12	RAN#98-e	RP-223300	0433		B	Big CR for coverage enhancement performance requirements for TS38.141-2	17.8.0

Change history							
Date	Meeting	TDoc	CR	Rev	Cat	Subject/Comment	New version
2022-12	RAN#98-e	RP-223315	0435	-	B	CR to 38.141-2 on introduction of Band 54	18.0.0
2022-12	RAN#98-e	RP-223319	0436	-	B	CR to 38.141-2 on introduction of Band n105	18.0.0
2023-03	RAN#99	RP-230513	0438		A	Correction of coverage enhancement BS demodulation requirement in 38.141-2 (R18 A)	18.1.0
2023-03	RAN#99	RP-230510	0440		A	Big CR to 38.141-2: demodulation requirements introduction for FR2-2	18.1.0
2023-03	RAN#99	RP-230505	0444		A	CR for TS 38.141-2, Correction on transmitter spatial emissions declaration in Annex G	18.1.0
2023-03	RAN#99	RP-230505	0448		A	Update to PUSCH performance test cases	18.1.0
2023-03	RAN#99	RP-230535	0449	1	B	CR to 38.141-2 on introduction of Band n54	18.1.0
2023-03	RAN#99	RP-230506	0452		A	CR to 38.141-2: FRC number corrections (Rel-18)	18.1.0
2023-03	RAN#99	RP-230513	0454		A	CR to 38.141-2: NOTE for n104 in BS co-existence table	18.1.0
2023-03	RAN#99	RP-230513	0456		A	CR to 38.141-2: BS Conformance, OBUE correction for 6G licensed band	18.1.0
2023-03	RAN#99	RP-230513	0458		A	CR to 38.141-2: BS Conformance, removal of [] for 47GHz Rx test	18.1.0
2023-03	RAN#99	RP-230514	0463		A	CR to 38.141-2: MU values for OBW requirements (Rel-18)	18.1.0
2023-03	RAN#99	RP-230513	0474		A	Correction CR on PUCCH JCE requirements for TS 38.141-2	18.1.0
2023-03	RAN#99	RP-230515	0475		A	Correction CR on PUCCH performance requirements for IIOT and URLLC for TS 38.141-2	18.1.0
2023-03	RAN#99	RP-230515	0476		A	Update to HST Model FR2 requirements	18.1.0
2023-03	RAN#99	RP-230510	0478		A	Big CR to TS 38.141-2: FR2-2 BS RF test requirements introduction, Rel-18	18.1.0
2023-06	RAN#100	RP-231347	0480		A	Draft CR 38.141-2: PUCCH requirements for FR2-2	18.2.0
2023-06	RAN#100	RP-231347	0482		A	CR to TS 38.141-2 on completion of measurement uncertainties for extending current NR operation to 71GHz	18.2.0
2023-06	RAN#100	RP-231354	0485		A	CR for TS 38.141-2 UL TA Demod requirements relative TPUT addition (NR_HST, Rel-18, CAT A)	18.2.0
2023-06	RAN#100	RP-231354	0487		A	CR for TS 38.141-2 UL TA Demod requirements relative TPUT addition (NR_HST_FR2, Rel-18, CAT A)	18.2.0
2023-06	RAN#100	RP-231347	0489		A	CR for TS38.141-2 FRC tables for FR2-2 PUSCH demodulation Rel-18	18.2.0
2023-06	RAN#100	RP-231350	0491	1	A	CR for TS38.141-2 on FRC table for PUSCH TBoMS Rel-18	18.2.0
2023-06	RAN#100	RP-231339	0495		A	CR to TS 38.141-2 - Maintenance related to bands n100 and n101	18.2.0
2023-06	RAN#100	RP-231352	0498		A	CR on 38.141-2: Updates to FRC of PUSCH requirements(Rel-18)	18.2.0
2023-06	RAN#100	RP-231347	0500		A	CR on 38.141-2: Updates to FR2-2 PUSCH requirements(Rel-18)	18.2.0
2023-06	RAN#100	RP-231347	0502		A	CR to 38.141-2: 71 GHz Extension BS conformance test Test Model clarification	18.2.0
2023-06	RAN#100	RP-231362	0505		B	CR to 38.141-2 on introduction of Band 106	18.2.0
2023-06	RAN#100	RP-231358	0509		A	CR to 38.141-2: Correction to ACLR and CACLR requirement	18.2.0
2023-09	RAN#101	RP-232505	0546	-	A	TS 38.141-2: Corrections	18.3.0
2023-09	RAN#101	RP-232490	0542	1	A	[NR_ext_to_71GHz-Perf] CR to TS 38.141-2: propagation conditions annex J reference corrections, Rel-18	18.3.0
2023-09	RAN#101	RP-232490	0539	-	A	[NR_FR1_35MHz_45MHz_BW-Core] CR to 38.141-2: Correction on EVM window length table R18	18.3.0
2023-09	RAN#101	RP-232488	0532	-	A	Update to Test Case 8.2.13 (FDD case, PUSCH Aggregation Factor 8), Rel18, 38.141-2	18.3.0
2023-09	RAN#101	RP-232492	0530	-	A	CR for TS38.141-2 add declaration and applicability rule for URLLC requirements	18.3.0
2023-09	RAN#101	RP-232490	0525	1	A	CR to TS 38.141-2 on completion of measurement uncertainties for extending current NR operation to 71GHz	18.3.0
2023-12	RAN#102	RP-233366	0551		B	CR to TS 38.141-2 on introduction NR bands n31 and n72	18.4.0
2023-12	RAN#102	RP-233345	0557		A	[NR_ext_to_71GHz-Perf] CR to 38.141-2: 71 GHz Extension BS performance test PRACH offset correction R18	18.4.0
2023-12	RAN#102	RP-233366	0561		B	CR to 38.141-2 on introduction of Band 106	18.4.0
2023-12	RAN#102	RP-233363	0552	1	F	[NR_FR1_lessthan_5MHz_BW-Core] CR for OTA Tx intermodulation requirements in certain region	18.4.0
2023-12	RAN#102	RP-233363	0563		B	Big CR for TS 38.141-2 on 4Tx demodulation requirements	18.4.0
2023-12	RAN#102	RP-233339	0550	1	A	[NR_n18-Perf] CR to TS 38.141-2 on correction of transmitter spurious emissions for protection of Band n18	18.4.0
2023-12	RAN#102	RP-233366	0553	1	B	CR to TS38.141-2 Introduction of n109	18.4.0

2023-03	RAN#103	RP-240553	0574		A	(TEI17) CR to TS 38.141-2 - BS spurious receiver protection note generalization R18	18.5.0
2023-03	RAN#103	RP-240558	0569		A	(NR_cov_enh-Perf) CR for TS38.141-2 TBoMS configuration Rel-18	18.5.0
2023-03	RAN#103	RP-240559	0576		A	(NR_ext_to_71GHz-Perf) CR to TS 38.141-2: Improvements of information related to test certainty and test tolerance in Subclause 4.1.2.2, Annex C.1 and Annex C.2	18.5.0
2023-03	RAN#103	RP-240591	0570		B	Big CR on 38.141-2 for FR2-1 UL 256QAM demodulation requirements	18.5.0
2023-03	RAN#103	RP-240592	0565		B	(NR_ATG-Perf) BigCR to TS 38.141-2 Introduction of demodulation performance requirements for NR ATG BS	18.5.0
2023-03	RAN#103	RP-240592	0566		B	CR for TS 38.141-2 on adding RF requirements for ATG BS	18.5.0
2024-06	RAN#104	RP-241419	0579		B	Big CR for further coverage enhancements requirements for TS38.141-2	18.6.0
2024-06	RAN#104	RP-241479	0581		F	[TEI] Re-inclusion of Channel Model Parameters for FR2 (Demodulation, Rel-18))	18.6.0
2024-06	RAN#104	RP-241433	0583		F	CR to 38.141-2: FRC number alignments among specifications	18.6.0
2024-06	RAN#104	RP-241396	0585		A	(NR_ext_to_71GHz-Perf) CR for 38.141-2 FR2-2 PUSCH demodulation requirements	18.6.0
2024-06	RAN#104	RP-241483	0586		F	CR to 38.141-2 Clarify the CA requirements for ATG BS in R18	18.6.0
2024-06	RAN#104	RP-241483	0587		F	CR on 38.141-2 for ATG demodulation requirements	18.6.0
2024-06	RAN#104	RP-241393	0591		A	(NR_bands_R17_BWs-Core) CR for OTA Tx intermodulation requirements in band n79 R18	18.6.0
2024-06	RAN#104	RP-241434	0582	1	F	CR to 38.141-2: Correction of FRC numbers for 256QAM, R=682.5/1024	18.6.0
2024-06	RAN#104	RP-241432	0589	1	B	Big CR on performance requirements for PUCCH format 2 for TS 38.141-2	18.6.0
2024-06	RAN#104	RP-241420	0592		B	Big CR for 38.141-2 MIMO evolution BS demodulation requirements	18.6.0
2024-09	RAN#105	RP-242159	0593		F	Correction on test applicability for PRACH repetition requirements	18.7.0
2024-09	RAN#105	RP-242194	0594	1	B	(TEI18) [NR NTN HAPS] CR for 38.141-2 on PRACH format 1 demodulation requirements	18.7.0
2024-09	RAN#105	RP-242169	0595	1	F	(NR_MIMO_evo_DL_UL-Perf) CR for 38.141-2 correction on test tolerance for PUSCH with enhanced DM-RS	18.7.0
2024-09	RAN#105	RP-242156	0596		F	(NR_ATG-Perf) CR for 38.141-2 Adding test tolerance for ATG requirements	18.7.0
2024-09	RAN#105	RP-241893	0597	3	F	(TEI18) [NR_bands_R17_BWs] CR to 38.141-2: Correction of regional requirement table	18.7.0
2024-09	RAN#105	RP-242193	0599		A	(TEI17)CR to TS 38.141-2 - BS spurious receiver protection note [MSR_BSRF_RX]	18.7.0
2024-09	RAN#105	RP-242159	0600	1	F	CR on test requirements for multiple PRACH transmission in TS 38.141-2	18.7.0
2024-09	RAN#105	RP-242163	0602		F	CR on performance requirements for PUCCH format 2 for TS 38.141-2	18.7.0

---

# History

<b>Document history</b>		
V18.5.0	May 2024	Publication
V18.6.0	August 2024	Publication
V18.7.0	October 2024	Publication