

ETSI TS 138 194 V19.2.0 (2026-04)



TECHNICAL SPECIFICATION

**5G;
NR;
Ambient IoT Base Station (BS) and Carrier-Wave (CW)
node radio transmission and reception
(3GPP TS 38.194 version 19.2.0 Release 19)**



Reference

RTS/TSGR-0438194vj20

Keywords

5G

ETSI

650 Route des Lucioles
F-06921 Sophia Antipolis Cedex - FRANCE

Tel.: +33 4 92 94 42 00 Fax: +33 4 93 65 47 16

Siret N° 348 623 562 00017 - APE 7112B
Association à but non lucratif enregistrée à la
Sous-Préfecture de Grasse (06) N° w061004871

Important notice

The present document can be downloaded from the
[ETSI Search & Browse Standards](#) application.

The present document may be made available in electronic versions and/or in print. The content of any electronic and/or print versions of the present document shall not be modified without the prior written authorization of ETSI. In case of any existing or perceived difference in contents between such versions and/or in print, the prevailing version of an ETSI deliverable is the one made publicly available in PDF format on [ETSI deliver](#) repository.

Users should be aware that the present document may be revised or have its status changed,
this information is available in the [Milestones listing](#).

If you find errors in the present document, please send your comments to
the relevant service listed under [Committee Support Staff](#).

If you find a security vulnerability in the present document, please report it through our
[Coordinated Vulnerability Disclosure \(CVD\)](#) program.

Notice of disclaimer & limitation of liability

The information provided in the present deliverable is directed solely to professionals who have the appropriate degree of experience to understand and interpret its content in accordance with generally accepted engineering or other professional standard and applicable regulations.

No recommendation as to products and services or vendors is made or should be implied.

No representation or warranty is made that this deliverable is technically accurate or sufficient or conforms to any law and/or governmental rule and/or regulation and further, no representation or warranty is made of merchantability or fitness for any particular purpose or against infringement of intellectual property rights.

In no event shall ETSI be held liable for loss of profits or any other incidental or consequential damages.

Any software contained in this deliverable is provided "AS IS" with no warranties, express or implied, including but not limited to, the warranties of merchantability, fitness for a particular purpose and non-infringement of intellectual property rights and ETSI shall not be held liable in any event for any damages whatsoever (including, without limitation, damages for loss of profits, business interruption, loss of information, or any other pecuniary loss) arising out of or related to the use of or inability to use the software.

Copyright Notification

No part may be reproduced or utilized in any form or by any means, electronic or mechanical, including photocopying and microfilm except as authorized by written permission of ETSI.

The content of the PDF version shall not be modified without the written authorization of ETSI.

The copyright and the foregoing restriction extend to reproduction in all media.

© ETSI 2026.
All rights reserved.

Intellectual Property Rights

Essential patents

IPRs essential or potentially essential to normative deliverables may have been declared to ETSI. The declarations pertaining to these essential IPRs, if any, are publicly available for **ETSI members and non-members**, and can be found in ETSI SR 000 314: "*Intellectual Property Rights (IPRs); Essential, or potentially Essential, IPRs notified to ETSI in respect of ETSI standards*", which is available from the ETSI Secretariat. Latest updates are available on the [ETSI IPR online database](#).

Pursuant to the ETSI Directives including the ETSI IPR Policy, no investigation regarding the essentiality of IPRs, including IPR searches, has been carried out by ETSI. No guarantee can be given as to the existence of other IPRs not referenced in ETSI SR 000 314 (or the updates on the ETSI Web server) which are, or may be, or may become, essential to the present document.

Trademarks

The present document may include trademarks and/or tradenames which are asserted and/or registered by their owners. ETSI claims no ownership of these except for any which are indicated as being the property of ETSI, and conveys no right to use or reproduce any trademark and/or tradename. Mention of those trademarks in the present document does not constitute an endorsement by ETSI of products, services or organizations associated with those trademarks.

DECT™, **PLUGTESTS™**, **UMTS™** and the ETSI logo are trademarks of ETSI registered for the benefit of its Members. **3GPP™**, **LTE™** and **5G™** logo are trademarks of ETSI registered for the benefit of its Members and of the 3GPP Organizational Partners. **oneM2M™** logo is a trademark of ETSI registered for the benefit of its Members and of the oneM2M Partners. **GSM®** and the GSM logo are trademarks registered and owned by the GSM Association.

Legal Notice

This Technical Specification (TS) has been produced by ETSI 3rd Generation Partnership Project (3GPP).

The present document may refer to technical specifications or reports using their 3GPP identities. These shall be interpreted as being references to the corresponding ETSI deliverables.

The cross reference between 3GPP and ETSI identities can be found at [3GPP to ETSI numbering cross-referencing](#).

Modal verbs terminology

In the present document "**shall**", "**shall not**", "**should**", "**should not**", "**may**", "**need not**", "**will**", "**will not**", "**can**" and "**cannot**" are to be interpreted as described in clause 3.2 of the [ETSI Drafting Rules](#) (Verbal forms for the expression of provisions).

"**must**" and "**must not**" are **NOT** allowed in ETSI deliverables except when used in direct citation.

Contents

Intellectual Property Rights	2
Legal Notice	2
Modal verbs terminology.....	2
Foreword.....	6
1 Scope	8
2 References	8
3 Definitions, symbols and abbreviations	8
3.1 Definitions	8
3.2 Symbols.....	9
3.3 Abbreviations	10
4 General	10
4.1 Relationship between minimum requirements and test requirements	10
4.2 Regional requirements.....	11
5 Operating bands and channel arrangement.....	11
5.1 General	11
5.2 Operating bands.....	11
5.3 BS channel bandwidth.....	11
5.3.1 R2D Channel bandwidth.....	11
5.3.1.1 General	11
5.3.1.2 R2D Transmission bandwidth configuration	12
5.3.1.3 Minimum guardband.....	12
5.3.1.4 RB alignment	13
5.3.1.5 R2D channel bandwidth per operating band	13
5.3.2 D2R Channel bandwidth.....	13
5.3.2.1 General	13
5.3.2.2 Minimum guardband.....	13
5.3.2.3 D2R channel bandwidth per operating band	13
5.4 Channel arrangement.....	14
5.4.1 R2D Channel raster.....	14
5.4.1.1 NR-ARFCN and channel raster.....	14
5.4.1.2 Channel raster to resource element mapping.....	14
5.4.1.3 Channel raster entries for each <i>operating band</i>	15
6 A-IoT BS transmitter characteristics	15
6.1 General	15
6.2 Base station output power	15
6.3 Transmit ON/OFF power	16
6.3.1 Transmitter OFF power	16
6.3.1.1 General	16
6.3.1.2 Minimum requirement for <i>A-IoT BS type 1-C</i>	16
6.3.2 Transmitter transient period.....	16
6.3.2.1 General	16
6.3.2.2 Minimum requirement for <i>A-IoT BS type 1-C</i>	16
6.4 Transmitted signal quality	17
6.4.1 Frequency error.....	17
6.4.1.1 General	17
6.4.1.2 Minimum requirement for <i>BS type 1-C</i>	17
6.4.2 Modulation quality.....	17
6.5 Unwanted emissions.....	19
6.5.1 General.....	19
6.5.2 Occupied bandwidth	19
6.5.2.1 General	19
6.5.2.2 Minimum requirement for <i>BS type 1-C</i>	19

6.5.3	Adjacent Channel Leakage Power Ratio	19
6.5.3.1	General	19
6.5.3.2	Limits and <i>Basic limits</i>	20
6.5.3.3	Minimum requirement for <i>BS type I-C</i>	20
6.5.4	Operating band unwanted emissions	20
6.5.4.1	General	20
6.5.4.2	<i>Basic limits</i>	21
6.5.4.3	Minimum requirements for <i>BS type I-C</i>	22
6.5.5	Transmitter spurious emissions	23
6.5.5.1	General	23
6.5.5.2	Basic limits	23
6.5.5.2.1	General transmitter spurious emissions requirements	23
6.5.5.2.2	Additional spurious emissions requirements	23
6.5.5.2.3	Co-location with other base stations	25
6.5.5.3	Minimum requirements for <i>BS type I-C</i>	25
7	A-IoT BS receiver characteristics	26
7.1	General	26
7.2	Reference sensitivity level	26
7.2.1	General	26
7.2.2	Minimum requirements for <i>BS type I-C</i>	26
7.3	In-band selectivity and blocking	26
7.3.1	Adjacent Channel Selectivity	26
7.3.2	In-band blocking	27
7.4	Out-of-band blocking	28
7.5	Receiver spurious emissions	29
7.6	Receiver intermodulation	30
7.6.2	Minimum requirement for BS type I-C	30
8	A-IoT CW transmitter characteristics	30
8.1	General	30
8.2	CW Output power	31
8.2.1	General	31
8.2.2	Minimum requirement	31
8.3	Frequency error	31
8.3.1	General	31
8.3.2	Minimum requirement	31
8.4	Transmit OFF power	31
8.4.1	General	31
8.4.2	Minimum requirement	31
8.5	Unwanted emission	32
8.5.1	General	32
8.5.2	Phase noise	32
8.5.2.1	General	32
8.5.2.2	Minimum requirement	32
8.5.3	Operating band unwanted emissions	32
8.5.3.1	General	32
8.5.3.2	Minimum requirement	32
8.5.4	Transmitter spurious emissions	33
8.5.4.1	General	33
8.5.4.2	Minimum requirement	33
Annex A (informative): D2R channel bandwidth		34
Annex B (normative): Reference measurement channels		35
B.1	Fixed Reference Channels for reference sensitivity level, ACS, in-band blocking, out-of-band blocking, (BPSK, OOK)	35
B.2	Fixed Reference Channels for R2D Tx requirements	35
Annex C (normative): Characteristics of the interfering signals		36
Annex D (Informative): Change history		36

History37

Foreword

This Technical Specification has been produced by the 3rd Generation Partnership Project (3GPP).

The contents of the present document are subject to continuing work within the TSG and may change following formal TSG approval. Should the TSG modify the contents of the present document, it will be re-released by the TSG with an identifying change of release date and an increase in version number as follows:

Version x.y.z

where:

- x the first digit:
 - 1 presented to TSG for information;
 - 2 presented to TSG for approval;
 - 3 or greater indicates TSG approved document under change control.
- y the second digit is incremented for all changes of substance, i.e. technical enhancements, corrections, updates, etc.
- z the third digit is incremented when editorial only changes have been incorporated in the document.

In the present document, modal verbs have the following meanings:

- shall** indicates a mandatory requirement to do something
- shall not** indicates an interdiction (prohibition) to do something

The constructions "shall" and "shall not" are confined to the context of normative provisions, and do not appear in Technical Reports.

The constructions "must" and "must not" are not used as substitutes for "shall" and "shall not". Their use is avoided insofar as possible, and they are not used in a normative context except in a direct citation from an external, referenced, non-3GPP document, or so as to maintain continuity of style when extending or modifying the provisions of such a referenced document.

- should** indicates a recommendation to do something
- should not** indicates a recommendation not to do something
- may** indicates permission to do something
- need not** indicates permission not to do something

The construction "may not" is ambiguous and is not used in normative elements. The unambiguous constructions "might not" or "shall not" are used instead, depending upon the meaning intended.

- can** indicates that something is possible
- cannot** indicates that something is impossible

The constructions "can" and "cannot" are not substitutes for "may" and "need not".

- will** indicates that something is certain or expected to happen as a result of action taken by an agency the behaviour of which is outside the scope of the present document
- will not** indicates that something is certain or expected not to happen as a result of action taken by an agency the behaviour of which is outside the scope of the present document
- might** indicates a likelihood that something will happen as a result of action taken by some agency the behaviour of which is outside the scope of the present document

might not indicates a likelihood that something will not happen as a result of action taken by some agency the behaviour of which is outside the scope of the present document

In addition:

is (or any other verb in the indicative mood) indicates a statement of fact

is not (or any other negative verb in the indicative mood) indicates a statement of fact

The constructions "is" and "is not" do not indicate requirements.

1 Scope

The present document establishes the minimum RF characteristics and minimum performance requirements of Ambient IoT Base Station (A-IoT BS) and Carrier-Wave (CW) node.

2 References

The following documents contain provisions which, through reference in this text, constitute provisions of the present document.

- References are either specific (identified by date of publication, edition number, version number, etc.) or non-specific.
- For a specific reference, subsequent revisions do not apply.
- For a non-specific reference, the latest version applies. In the case of a reference to a 3GPP document (including a GSM document), a non-specific reference implicitly refers to the latest version of that document *in the same Release as the present document*.

- [1] 3GPP TR 21.905: "Vocabulary for 3GPP Specifications".
 - [2] ITU-R Recommendation SM.329: "Unwanted emissions in the spurious domain".
 - [3] 3GPP TS 38.195: "Ambient IoT Base Station (BS) and Carrier-Wave (CW) node conformance testing".
 - [4] Recommendation ITU-R M.1545: "Measurement uncertainty as it applies to test limits for the terrestrial component of International Mobile Telecommunications-2000".
 - [5] 3GPP TS 38.211: "Physical channels and modulation".
 - [6] 3GPP TS 38.104: "NR; Base Station (BS) radio transmission and reception".
 - [7] 3GPP TS 38.291: "NR; Ambient IoT Physical layer".
 - [8] 3GPP TS 25.104: "Base Station (BS) radio transmission and reception (FDD)".
 - [9] 3GPP TS 36.104: "Evolved Universal Terrestrial Radio Access (E-UTRA); Base Station (BS) radio transmission and reception".
 - [10] 3GPP TS 38.104: "NR; Base Station (BS) radio transmission and reception".
-

3 Definitions, symbols and abbreviations

3.1 Definitions

For the purposes of the present document, the terms given in TR 21.905 [1] and the following apply. A term defined in the present document takes precedence over the definition of the same term, if any, in TR 21.905 [1].

antenna connector: connector at the conducted interface of the *BS type 1-C*

active transmitter unit: transmitter unit which is ON, and has the ability to send modulated data streams that are parallel and distinct to those sent from other transmitter units to a *BS type 1-C antenna connector*

Base Station RF Bandwidth: RF bandwidth in which a base station transmits and/or receives single or multiple carrier(s) within a supported *operating band*

NOTE: In single carrier operation, the *Base Station RF Bandwidth* is equal to the *BS channel bandwidth*.

Base Station RF Bandwidth edge: frequency of one of the edges of the *Base Station RF Bandwidth*.

basic limit: emissions limit relating to the power supplied by a single transmitter to a single antenna transmission line in ITU-R SM.329 [2] used for the formulation of unwanted emission requirements for FR1

BS channel bandwidth: RF bandwidth supporting a single NR RF carrier with the *transmission bandwidth* configured in the D2R or R2D

NOTE 1: The *BS channel bandwidth* is measured in MHz and is used as a reference for transmitter and receiver RF requirements.

NOTE 2: It is possible for the BS to transmit to and/or receive from one or more UE bandwidth parts that are smaller than or equal to the *BS transmission bandwidth configuration*, in any part of the *BS transmission bandwidth configuration*.

BS D2R channel bandwidth for RX requirements definition: Channel bandwidth on which BS RX requirements defined for D2R, it can be different from BS D2R channel bandwidth defined in Table 5.3.2.3-1.

BS transmission bandwidth configuration: set of resource blocks located within the *BS channel bandwidth* which may be used for transmitting by the BS

BS type 1-C: NR base station operating at FR1 with requirements set consisting only of conducted requirements defined at individual *antenna connectors*

maximum carrier output power: mean power level measured per carrier at the indicated interface, during the *transmitter ON period* in a specified reference condition

maximum total output power: mean power level measured within the *operating band* at the indicated interface, during the *transmitter ON period* in a specified reference condition

measurement bandwidth: RF bandwidth in which an emission level is specified

operating band: frequency range in which NR operates (paired or unpaired), that is defined with a specific set of technical requirements

NOTE: The *operating band(s)* for a BS is declared by the manufacturer according to the designations in tables 5.2-1.

rated carrier output power: mean power level associated with a particular carrier the manufacturer has declared to be available at the indicated interface, during the *transmitter ON period* in a specified reference condition

transmission bandwidth: RF Bandwidth of an instantaneous transmission from a UE or BS, measured in resource block units

transmitter OFF period: time period during which the BS transmitter is not allowed to transmit

transmitter ON period: time period during which the BS transmitter is transmitting data and/or reference symbols

transmitter transient period: time period during which the transmitter is changing from the OFF period to the ON period or vice versa

3.2 Symbols

For the purposes of the present document, the following symbols apply:

BW_{Channel}	<i>BS channel bandwidth</i>
BW_{Config}	<i>Transmission bandwidth</i> , where $BW_{\text{Config}} = N_{\text{RB}} \times \text{SCS} \times 12$
Δf	Separation between the <i>channel edge</i> frequency and the nominal -3 dB point of the measuring filter closest to the carrier frequency
ΔF_{Global}	Global frequency raster granularity
Δf_{max}	$f_{\text{offset}_{\text{max}}}$ minus half of the bandwidth of the measuring filter
Δf_{OBUE}	Maximum offset of the <i>operating band</i> unwanted emissions mask from the downlink <i>operating band edge</i>
Δf_{OOB}	Maximum offset of the out-of-band boundary from the uplink <i>operating band edge</i>
ΔF_{Raster}	Channel raster granularity
F_C	<i>RF reference frequency</i> on the channel raster, given in table 5.4.2.2-1

F_{filter}	Filter centre frequency
f_{offset}	Separation between the <i>channel edge</i> frequency and the centre of the measuring
$f_{\text{offset}_{\text{max}}}$	The offset to the frequency Δf_{OBUe} outside the downlink <i>operating band</i>
F_{REF}	RF reference frequency
$F_{\text{REF-Offs}}$	Offset used for calculating F_{REF}
N_{RB}	<i>Transmission bandwidth configuration</i> , expressed in resource blocks
N_{REF}	A-IoT Absolute Radio Frequency Channel Number (A-IoT-ARFCN)
$N_{\text{REF-Offs}}$	Offset used for calculating N_{REF}
$P_{\text{max,c,AC}}$	<i>Maximum carrier output power</i> measured per <i>antenna connector</i>
$P_{\text{rated,c,AC}}$	The <i>rated carrier output power per antenna connector</i>
$P_{\text{rated,t,AC}}$	The <i>rated total output power</i> declared at the <i>antenna connector</i>
P_{REFSENS}	Conducted Reference Sensitivity power level

3.3 Abbreviations

For the purposes of the present document, the abbreviations given in TR 21.905 [1] and the following apply. An abbreviation defined in the present document takes precedence over the definition of the same abbreviation, if any, in TR 21.905 [1].

2SB	Double sideband
ACLR	Adjacent Channel Leakage Ratio
ACS	Adjacent Channel Selectivity
AWGN	Additive White Gaussian Noise
A-IoT	Ambient IoT
A-IoT RAN	Ambient IoT Radio Access Network
BPSK	Binary phase-shift keying
BS	Base Station
BW	Bandwidth
CW	Carrier-wave
CW2D	Carrier-wave, or carrier-wave node, to device
D2R	Device to reader
FR	Frequency Range
FRC	Fixed Reference Channel
OOK	On-off keying
R2D	Reader to device
REFSENS	Reference Sensitivity
RF	Radio frequency
SCS	Sub-Carrier Spacing
SFO	Sampling-frequency offset
UEM	Unwanted Emissions Mask

4 General

4.1 Relationship between minimum requirements and test requirements

Conformance to the present specification is demonstrated by fulfilling the test requirements specified in the conformance specification TS 38.195[3].

The minimum requirements given in this specification make no allowance for measurement uncertainty. The test specifications TS 38.195 define test tolerances. These test tolerances are individually calculated for each test. The test tolerances are used to relax the minimum requirements in this specification to create test requirements. For some requirements, including regulatory requirements, the test tolerance is set to zero.

The measurement results returned by the test system are compared - without any modification - against the test requirements as defined by the shared risk principle.

The shared risk principle is defined in recommendation ITU-R M.1545. [4]

4.2 Regional requirements

Some requirements in the present document may only apply in certain regions either as optional requirements, or as mandatory requirements set by local and regional regulation. It is normally not stated in the 3GPP specifications under what exact circumstances the regional requirements apply, since this is defined by local or regional regulation.

5 Operating bands and channel arrangement

5.1 General

The channel arrangements presented in this clause are based on the *operating bands* and *BS channel bandwidths* defined in the present release of specifications.

NOTE: Other *operating bands* and *BS channel bandwidths* may be considered in future releases.

Requirements throughout the RF specifications are in many cases defined separately for different frequency ranges (FR). The frequency ranges in which A-IoT can operate according to the present version of the specification are identified as described in table 5.1-1.

Table 5.1-1: Definition of frequency ranges

Frequency range designation	Corresponding frequency range
FR1	410 MHz – 7125 MHz

5.2 Operating bands

A-IoT is designed to operate in the *operating bands* defined in table 5.2-1

Table 5.2-1: A-IoT operating bands in FR1

A-IoT operating band	Uplink (D2R&CW) operating band BS receive / UE transmit $F_{UL,low} - F_{UL,high}$ (MHz)	Downlink (R2D) operating band BS transmit / UE receive $F_{DL,low} - F_{DL,high}$ (MHz)	Duplex mode
n5	824 – 849	869 – 894	FDD
n8	880 – 915	925 – 960	FDD
n28	703 – 748	758 – 803	FDD

5.3 BS channel bandwidth

5.3.1 R2D Channel bandwidth

5.3.1.1 General

The *R2D channel bandwidth* supports a single RF carrier in R2D link at the reader.

The relationship between the R2D channel bandwidth, the guardband and the *transmission bandwidth configuration* is shown in figure 5.3.1.1-1.

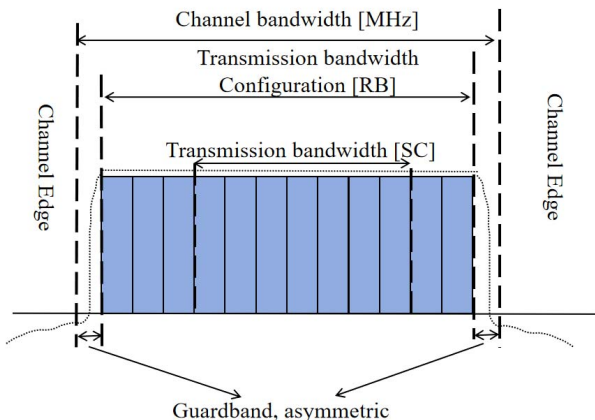

Figure 5.3.1.1-1: Definition of channel bandwidth and *transmission bandwidth configuration* for one reader channel

5.3.1.2 R2D Transmission bandwidth configuration

The *transmission bandwidth configuration* N_{RB} for each *R2D channel bandwidth* and subcarrier spacing is specified in table 5.3.1.2-1.

Table 5.3.1.2-1: R2D Transmission bandwidth configuration N_{RB} for FR1

R2D Channel Bandwidth	200 kHz	400 kHz	600 kHz	800 kHz
SCS (kHz)	N_{RB}	N_{RB}	N_{RB}	N_{RB}
15	1	2	3	4

NOTE: All BS Tx and device Rx requirements are defined based on *transmission bandwidth configuration* specified in table 5.3.1.2-1.

5.3.1.3 Minimum guardband

The minimum guardband for each *R2D channel bandwidth* and SCS is specified in table 5.3.3-1.

Table 5.3.1.3-1: Minimum guardband (FR1)

R2D Channel Bandwidth	200 kHz	400 kHz	600 kHz	800 kHz
Minimum guardband (kHz)	2.5	12.5	22.5	32.5

The number of RBs configured in any *R2D channel bandwidth* shall ensure that the minimum guardband specified in this clause is met.

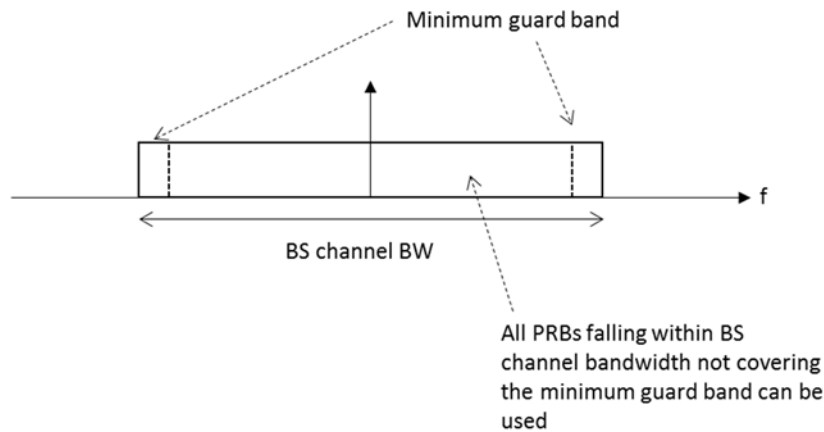

Figure 5.3.1.3-1: Reader PRB utilization

5.3.1.4 RB alignment

For each *R2D channel bandwidth*, *BS transmission bandwidth configuration* must fulfil the minimum guardband requirement specified in clause 5.3.3.

5.3.1.5 R2D channel bandwidth per operating band

The requirements in this specification apply to the combination of *BS channel bandwidths*, *SCS* and *operating bands* shown in table 5.3.5-1 for FR1. The *transmission bandwidth configuration* in table 5.3.2-1 shall be supported for each of the *BS channel bandwidths* within the BS capability. The *BS channel bandwidths* are specified for the Tx path.

Table 5.3.5-1: BS channel bandwidths and SCS per operating band

A-IoT Bands	SCS (kHz)	<i>R2D channel bandwidth</i> (kHz)			
		200	400	600	800
n5, n8, n28	15	200	400	600	800

5.3.2 D2R Channel bandwidth

5.3.2.1 General

The D2R channel bandwidth supports a single RF carrier in the D2R link at the BS. From a BS perspective, different D2R channel bandwidths may be supported within the same spectrum for backscattering from devices connected to the BS.

5.3.2.2 Minimum guardband

The minimum guardband for each D2R channel bandwidth at BS side is specified as 10% D2R channel bandwidth at BS side.

5.3.2.3 D2R channel bandwidth per operating band

The requirements in this specification only apply to the *operating band* n8 shown in in table 5.3.2.3-1 for BS.

Table 5.3.2.3-1: BS D2R channel bandwidth

BS D2R channel bandwidth (kHz)									
Nominal D2R transmission Bandwidth without SFO (kHz)	Nominal Small frequency shift without SFO(kHz)								
	3.75	7.5	15	30	60	120	240	480	720
15	19	28	46	83	156	303	596	1183	
30		37	55	92	165	312	605	1192	
60			74	110	184	330	624	1210	
120				147	220	367	660	1247	
240					294	440	734	1320	
480						587	880	1467	
960							1174	1760	
2880									3520

5.4 Channel arrangement

5.4.1 R2D Channel raster

5.4.1.1 NR-ARFCN and channel raster

The global frequency raster defines a set of *RF reference frequencies* F_{REF} . The *RF reference frequency* is used in signalling to identify the position of RF channels and other elements. The granularity of the global frequency raster is ΔF_{Global} .

RF reference frequencies are designated by an NR Absolute Radio Frequency Channel Number (NR-ARFCN) in the range [0...3279165] on the global frequency raster. The relation between the NR-ARFCN and the *RF reference frequency* F_{REF} in MHz is given by the following equation, where $F_{\text{REF-Offs}}$ and $N_{\text{REF-Offs}}$ are given in table 5.4.1.1-1 and N_{REF} is the NR-ARFCN.

$$F_{\text{REF}} = F_{\text{REF-Offs}} + \Delta F_{\text{Global}} (N_{\text{REF}} - N_{\text{REF-Offs}})$$

Table 5.4.1.1-1: NR-ARFCN parameters for the global frequency raster

Range of frequencies (MHz)	ΔF_{Global} (kHz)	$F_{\text{REF-Offs}}$ (MHz)	$N_{\text{REF-Offs}}$	Range of N_{REF}
0 – 3000	5	0	0	0 – 599999

The *channel raster* defines a subset of *RF reference frequencies* that can be used to identify the RF channel position in the uplink and downlink. The *RF reference frequency* for an RF channel maps to a resource element on the carrier. For each *operating band*, a subset of frequencies from the global frequency raster are applicable for that band and forms a channel raster with a granularity ΔF_{Raster} , which may be equal to or larger than ΔF_{Global} .

The mapping between the *channel raster* and corresponding resource element is given in clause 5.4.1.2. The applicable entries for each *operating band* are defined in clause 5.4.1.3.

5.4.1.2 Channel raster to resource element mapping

The mapping between the *RF reference frequency* on the channel raster and the corresponding resource element is given in table 5.4.1.2-1 and can be used to identify the RF channel position. The mapping depends on the total number of RBs that are allocated in the channel and applies to both UL and DL. The mapping must apply to at least one numerology supported by the BS.

Table 5.4.1.2-1: Channel Raster to Resource Element Mapping

	$N_{RB} \bmod 2 = 0$	$N_{RB} \bmod 2 = 1$
Resource element index k	0	6
Physical resource block number n_{PRB}	$n_{PRB} = \left\lfloor \frac{N_{RB}}{2} \right\rfloor$	$n_{PRB} = \left\lfloor \frac{N_{RB}}{2} \right\rfloor$

k , n_{PRB} and N_{RB} are as defined in TS 38.211 [5].

5.4.1.3 Channel raster entries for each *operating band*

The RF channel positions on the channel raster in each A-IoT operating band are given through the applicable NR-ARFCN in table 5.4.1.3-1, using the channel raster to resource element mapping in clause 5.4.1.2.

Channel raster is defined with $\Delta F_{\text{Raster}} = 2 \times \Delta F_{\text{Global}}$. In this case every 2th NR-ARFCN within the operating band are applicable for the channel raster within the operating band and the step size for the channel raster in Table 5.4.1.3-1 is given as <2>.

Table 5.4.1.3-1: Applicable NR-ARFCN per operating band for enhanced channel raster

A-IoT operating band	ΔF_{Raster} (kHz)	Uplink Range of N_{REF} (First – <Step size> – Last)	Downlink Range of N_{REF} (First – <Step size> – Last)
n5	10	164800 – <2> – 169800	173800 – <2> – 178800
n8	10	176000 – <2> – 183000	185000 – <2> – 192000
n28	10	140600 – <2> – 149600	151600 – <2> – 160600

NOTE 1: The channel numbers that designate carrier frequencies so close to the operating band edges that the carrier extends beyond the operating band edge shall not be used. These channel numbers shall also be such that the minimum guard band for each channel bandwidth and SCS specified in Table 5.3.1.3 and 5.3.2.2 are met for carriers located at the upper or lower edge of an operating band.

6 A-IoT BS transmitter characteristics

6.1 General

Unless otherwise stated, the conducted transmitter characteristics are specified at the antenna connector for BS type 1-C. A-IoT BS transmitter characteristics refer to that for BS type 1-C in clause 6 in TS38.104[6].

6.2 Base station output power

6.2.1 General

The A-IoT BS conducted output power requirement is at antenna connector for A-IoT BS type 1-C.

The rated carrier output power of the A-IoT BS type 1-C shall be less than or equal to 38dBm.

6.3 Transmit ON/OFF power

6.3.1 Transmitter OFF power

6.3.1.1 General

Transmitter OFF power for A-IoT BS is defined as the mean power measured over $70/N$ us filtered with a square filter of bandwidth equal to the transmission bandwidth configuration of the BS (BW_{Config}) centred on the assigned channel frequency during the *transmitter OFF period*. $N = \text{SCS}/15$, where SCS is Sub Carrier Spacing in kHz.

6.3.1.2 Minimum requirement for A-IoT BS type 1-C

For A-IoT BS type 1-C, the requirements for transmitter OFF power spectral density shall be less than -85 dBm/MHz per antenna connector.

6.3.2 Transmitter transient period

6.3.2.1 General

The transmitter transient period for A-IoT BS is the time period during which the transmitter is changing from the transmitter OFF period to the transmitter ON period or vice versa. The transmitter transient period is illustrated in figure 6.4.2.1-1.

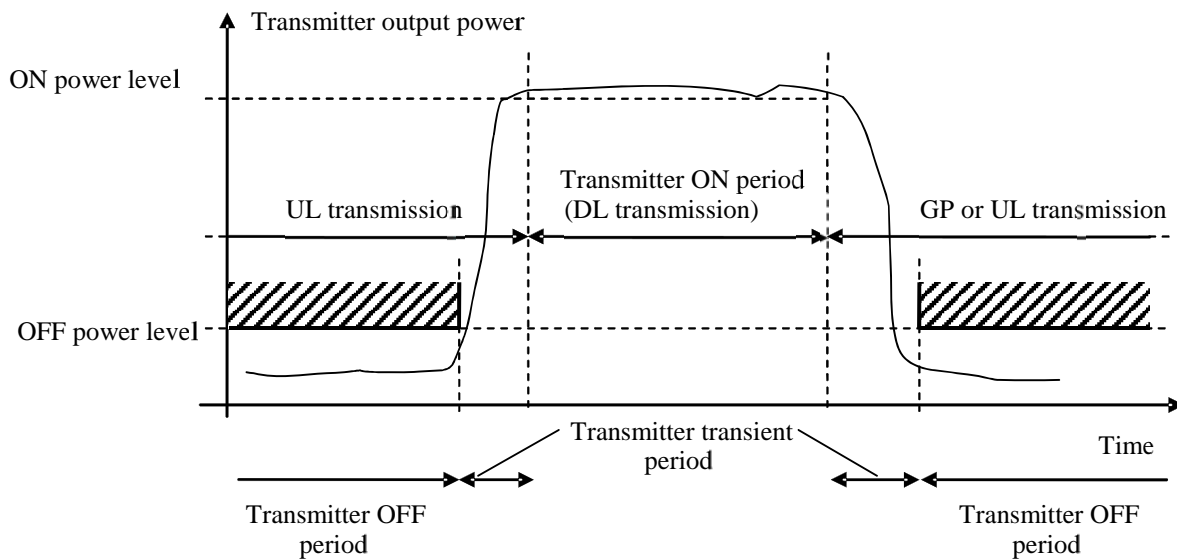

Figure 6.3.2.1-1: Example of relations between transmitter ON period, transmitter OFF period and transmitter transient period

For A-IoT BS type 1-C, this requirement shall be applied at the antenna connector supporting transmission in the operating band.

6.3.2.2 Minimum requirement for A-IoT BS type 1-C

For A-IoT BS type 1-C, the transmitter transient period shall be shorter than the values listed in the minimum requirement table 6.3.2.2-1.

Table 6.3.2.2-1: Minimum requirement for the transmitter transient period for A-IoT BS type 1-C

Transition	Transient period length (μ s)
OFF to ON	10
ON to OFF	10

6.4 Transmitted signal quality

6.4.1 Frequency error

6.4.1.1 General

The requirements in clause 6.4.1 apply to the transmitter ON period.

Frequency error is the measure of the difference between the actual BS transmit frequency and the assigned frequency. The same source shall be used for RF frequency and data clock generation.

For BS type 1-C this requirement shall be applied at the antenna connector supporting transmission in the operating band.

6.4.1.2 Minimum requirement for BS type 1-C

For BS type 1-C, the modulated carrier frequency of each NR carrier configured by the BS shall be accurate to within the accuracy range given in table 6.4.1.2-1 observed over 1 ms.

Table 6.4.1.2-1: Frequency error minimum requirement

BS class	Accuracy
Medium Range BS	± 0.1 ppm

6.4.2 Modulation quality

Based on TS38.291[7], R2D signal includes SIP (Start indicator part), CAP (Clock acquisition part), PRDCH, the R2D postamble and padding if needed.

A_n is measured peak high level for the n^{th} chip, in units of V/m or A/m

B_n is measured peak low level for the n^{th} chip, in units of V/m or A/m

A_{navg} is the measured average high level for the n^{th} chip during 1/2 duration above 90% A_n , in units of V/m or A/m

B_{navg} is the measured average low level for the n^{th} chip during 1/2 duration below 10% A_n , in units of V/m or A/m

Modulation depth:

Modulation depth is defined with equation below and modulation depth for OOK chip 0/1 shall meet the requirements in Table 6.4.2-1.

Modulation depth = $(A_{\text{navg}} - B_{\text{navg}}) / A_{\text{navg}}$

The envelope of electric field strength for OOK chip 0 RF pulse shall comply the timing mask in Figure 6.4.2-1 and meet the requirements in Table 6.4.2-1. The envelope of electric field strength for OOK Bit 0 shall decrease monotonically from 90% to less than 10 % of initial value E_{initial} during t_1 . The envelope of electric field strength for OOK Bit 0 shall increase monotonically from 10% to less than 90 % of its initial value E_{initial} during t_3 . The initial value E_{initial} is defined as the field strength difference between A_{navg} and B_{navg} .

RF Envelop Rise Time:

The $T_{r,10-90}$ measures the rise of the OOK bit 0 pulse and starts when envelop rises to 10% level of the initial value $E_{initial}$ and ends when the envelop rises to 90% of the initial value $E_{initial}$.

RF Envelop Fall Time:

The $T_{f,10-90}$ measures the fall time of the OOK chip 0 pulse and starts when envelop falls to 90% level of the initial value $E_{initial}$ and ends when the envelop falls to 10% of the initial value $E_{initial}$.

$T_{f,10-90}$ starts when the envelop drops to the 90% level of the initial value $E_{initial}$ and ends when envelop rise to 10% level of the initial value $E_{initial}$.

Ripple:

$$\text{Ripple_high (\%)} = ((A_n - A_{\text{avg}}) / (A_{\text{avg}} - B_{\text{avg}})) \times 100\%$$

$$\text{Ripple_low (\%)} = ((B_n - B_{\text{avg}}) / (A_{\text{avg}} - B_{\text{avg}})) \times 100\%$$

In case of an overshoot or undershoot the field shall remain within +/- Ripple_high % of $E_{initial}$ for OOK chip 1 and +/-Ripple_low % of $E_{initial}$ for OOK chip 0.

Pulsewidth

The PW measures the time between envelop falling edge at 50% of the initial value $E_{initial}$ and envelop rising edge at 50% of the initial value $E_{initial}$.

Table 6.4.2-1: A-IoT BS RF envelope parameters

R2D Chip duration: T_c	Parameter	Symbol	Value	Units
$T_c = \frac{10^3}{M * 15} (\mu s)$ $M \in \{2,6,12,24\}$	Modulation Depth	$(A-B)/A$	80	%
	RF Envelope Ripple	Ripple_high Ripple_low	$\leq \pm 15$	%
	RF Envelop Rise Time	$T_{r,10-90}$	$\leq 0.66T_c$	μs
	RF Envelop Fall Time	$T_{f,10-90}$	$\leq 0.66T_c$	μs
	RF Pulsewidth	PW	$\leq 1.3 T_c$	μs

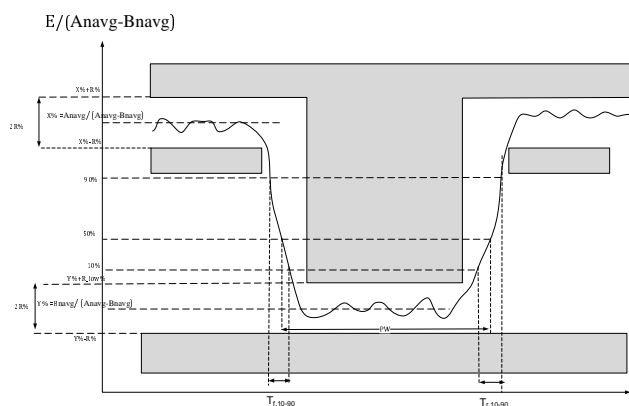

Figure 6.4.2-1: Timing mask for OOK chip 0 pulse

6.5 Unwanted emissions

6.5.1 General

Unwanted emissions consist of out-of-band emissions and spurious emissions according to ITU definitions [2]. In ITU terminology, out of band emissions are unwanted emissions immediately outside the BS R2D channel bandwidth resulting from the modulation process and non-linearity in the transmitter but excluding spurious emissions. Spurious emissions are emissions which are caused by unwanted transmitter effects such as harmonics emission, parasitic emission, intermodulation products and frequency conversion products, but exclude out of band emissions.

The out-of-band emissions requirement for the BS transmitter is specified both in terms of Adjacent Channel Leakage power Ratio (ACLR) and *operating band* unwanted emissions (OBUE).

The maximum offset of the *operating band* unwanted emissions mask from the *operating band* edge is Δf_{OBUE} . The Operating band unwanted emissions define all unwanted emissions in each supported downlink *operating band* plus the frequency ranges Δf_{OBUE} above and Δf_{OBUE} below each band. Unwanted emissions outside of this frequency range are limited by a spurious emissions requirement.

The values of Δf_{OBUE} are defined in table 6.5.1-1 for the NR *operating bands*.

Table 6.5.1-1: Maximum offset of OBUE outside the downlink *operating band*

BS type	Operating band characteristics	Δf_{OBUE} (MHz)
<i>BS type 1-C</i>	$F_{\text{DL_high}} - F_{\text{DL_low}} \leq 200$ MHz	10

6.5.2 Occupied bandwidth

6.5.2.1 General

The occupied bandwidth requirement shall apply during transmitter ON period for a single transmitted carrier. The minimum requirement below may be applied regionally. There may also be regional requirements to declare the occupied bandwidth.

For BS type 1-C this requirement shall be applied at the antenna connector supporting transmission in the operating band.

6.5.2.2 Minimum requirement for *BS type 1-C*

The occupied bandwidth for each NR carrier shall be less than the BS R2D channel bandwidth.

6.5.3 Adjacent Channel Leakage Power Ratio

6.5.3.1 General

Adjacent Channel Leakage power Ratio (ACLR) is the ratio of the filtered mean power centred on the assigned channel frequency to the filtered mean power centred on an adjacent channel frequency.

The requirements shall apply outside the Base Station RF Bandwidth or Radio Bandwidth whatever the type of transmitter considered (single carrier or multi-carrier) and for all transmission modes foreseen by the manufacturer's specification.

The requirement shall apply during the transmitter ON period.

6.5.3.2 Limits and *Basic limits*

The ACLR is defined with a square filter of bandwidth equal to the transmission bandwidth configuration of the transmitted signal (BW_{Config}) centred on the assigned channel frequency and a filter centred on the adjacent channel frequency according to the tables below.

For operation in paired spectrum, the ACLR shall be higher than the value specified in table 6.5.3.2-1 in band n5, n8 and n28.

Table 6.5.3.2-1: Base station ACLR limit

BS R2D channel bandwidth of lowest/highest carrier transmitted BW_{Channel} (kHz)	BS adjacent channel centre frequency offset below the lowest or above the highest carrier centre frequency transmitted (kHz)	Assumed adjacent channel carrier (informative)	Filter on the adjacent channel frequency and corresponding filter bandwidth	ACLR limit
200	300	A-IoT of same BW	Square (180 kHz)	40dB
	500	A-IoT of same BW	Square (180 kHz)	45dB
400	500	A-IoT of same BW	Square (360 kHz)	40dB
	900	A-IoT of same BW	Square (360 kHz)	45dB
600	700	A-IoT of same BW	Square (540 kHz)	40dB
	1300	A-IoT of same BW	Square (540 kHz)	45dB
800	900	A-IoT of same BW	Square (720 kHz)	40dB
	1700	A-IoT of same BW	Square (720 kHz)	45dB

6.5.3.3 Minimum requirement for *BS type 1-C*

The ACLR limits in table 6.5.3.2-1 shall apply for each antenna connector.

6.5.4 Operating band unwanted emissions

6.5.4.1 General

Unless otherwise stated, the operating band unwanted emission (OBUE) limits in FR1 are defined from 10MHz below the lowest frequency of each supported downlink operating band up to 10MHz above the highest frequency of each supported downlink operating band. The values of 10MHz are defined in table 6.5.1-1 for the NR operating bands.

The requirements shall apply whatever the type of transmitter considered and for all transmission modes foreseen by the manufacturer's specification.

Basic limits are specified in the tables below, where:

- Δf is the separation between the channel edge frequency and the nominal -3dB point of the measuring filter closest to the carrier frequency.
- f_{offset} is the separation between the channel edge frequency and the centre of the measuring filter.
- $f_{\text{offset}_{\text{max}}}$ is the offset to the frequency 10MHz outside the downlink *operating band*.
- Δf_{max} is equal to $f_{\text{offset}_{\text{max}}}$ minus half of the bandwidth of the measuring filter.

For Medium Range BS, the requirements in clause 6.5.4.2.3 shall apply.

6.5.4.2 Basic limits

For A-IoT medium range BS (maximum output power $31 < P_{rated,c} \leq 38$ dBm), emissions shall not exceed the maximum levels specified in Table 6.5.4.2.3-1.

Table 6.5.4.2.3-1: A-IoT medium range BS operating band unwanted emission limits, BS maximum output power $31 < P_{rated,c} \leq 38$ dBm

BS R2D channel bandwidth	Frequency offset of measurement filter -3dB point, Δf	Frequency offset of measurement filter centre frequency, f_{offset}	Minimum requirement	Measurement bandwidth
200kHz	$0 \text{ MHz} \leq \Delta f < 0.05 \text{ MHz}$	$0.015 \text{ MHz} \leq f_{offset} < 0.065 \text{ MHz}$	$P_{rated,c} - 38\text{dB} - 60 \left(\frac{f_{offset}}{\text{MHz}} - 0.015 \right) \text{dB}$	30 kHz
	$0.05 \text{ MHz} \leq \Delta f < 0.15 \text{ MHz}$	$0.065 \text{ MHz} \leq f_{offset} < 0.165 \text{ MHz}$	$P_{rated,c} - 41\text{dB} - 160 \left(\frac{f_{offset}}{\text{MHz}} - 0.065 \right) \text{dB}$	30 kHz
	$0.15 \text{ MHz} \leq \Delta f < 0.6 \text{ MHz}$	$0.165\text{MHz} \leq f_{offset} < 0.615\text{MHz}$	$P_{rated,c} - 58\text{dB} - \frac{5}{3} \left(\frac{f_{offset}}{\text{MHz}} - 0.015 \right) \text{dB}$	30 kHz
	$0.6 \text{ MHz} \leq \Delta f < 1 \text{ MHz}$	$0.615\text{MHz} \leq f_{offset} < 1.015\text{MHz}$	$P_{rated,c} - 53\text{dB} - 15 \left(\frac{f_{offset}}{\text{MHz}} - 0.215 \right) \text{dB}$	30 kHz
	$1 \text{ MHz} \leq \Delta f \leq 2.8 \text{ MHz}$	$1.5 \text{ MHz} \leq f_{offset} < 3.3 \text{ MHz}$	$P_{rated,c} - 52 \text{ dB}$	1 MHz
	$2.8 \text{ MHz} \leq \Delta f \leq 5 \text{ MHz}$	$3.3 \text{ MHz} \leq f_{offset} < 5.5 \text{ MHz}$	$\min(P_{rated,c} - 52 \text{ dB}, -15\text{dBm})$	1 MHz
	$5 \text{ MHz} \leq \Delta f \leq \Delta f_{max}$	$5.5 \text{ MHz} \leq f_{offset} < f_{offsetmax}$	$P_{rated,c} - 56 \text{ dB}$	1 MHz
400kHz	$0 \text{ MHz} \leq \Delta f < 0.4 \text{ MHz}$	$0.015 \text{ MHz} \leq f_{offset} < 0.415 \text{ MHz}$	$P_{rated,c} - 40\text{dB} - \frac{11}{0.4} \left(\frac{f_{offset}}{\text{MHz}} - 0.015 \right) \text{dB}$	30 kHz
	$0.4 \text{ MHz} \leq \Delta f < 0.8 \text{ MHz}$	$0.415 \text{ MHz} \leq f_{offset} < 0.815 \text{ MHz}$	$P_{rated,c} - 51\text{dB} - \frac{5}{0.4} \left(\frac{f_{offset}}{\text{MHz}} - 0.415 \right) \text{dB}$	30 kHz
	$0.8 \text{ MHz} \leq \Delta f < 1.6 \text{ MHz}$	$0.815 \text{ MHz} \leq f_{offset} < 1.6 \text{ MHz}$	$P_{rated,c} - 56\text{dB}$	30 kHz
	$1.6 \text{ MHz} \leq \Delta f < \Delta f_{max}$	$1.6 \text{ MHz} \leq f_{offset} < f_{offsetmax}$	-25dBm	100kHz
600kHz	$0 \text{ MHz} \leq \Delta f < 0.6 \text{ MHz}$	$0.015 \text{ MHz} \leq f_{offset} < 0.615 \text{ MHz}$	$P_{rated,c} - 40\text{dB} - \frac{13}{0.6} \left(\frac{f_{offset}}{\text{MHz}} - 0.015 \right) \text{dB}$	30 kHz
	$0.6 \text{ MHz} \leq \Delta f < 1.2 \text{ MHz}$	$0.615 \text{ MHz} \leq f_{offset} < 1.2 \text{ MHz}$	$P_{rated,c} - 53\text{dB} - \frac{5}{0.6} \left(\frac{f_{offset}}{\text{MHz}} - 0.615 \right) \text{dB}$	30 kHz
	$1.2 \text{ MHz} \leq \Delta f < 1.8 \text{ MHz}$	$1.2 \text{ MHz} \leq f_{offset} < 1.8 \text{ MHz}$	$P_{rated,c} - 58\text{dB}$	30 kHz
	$1.8 \text{ MHz} \leq \Delta f < \Delta f_{max}$	$1.8 \text{ MHz} \leq f_{offset} < f_{offsetmax}$	-25dBm	100K
800kHz	$0 \text{ MHz} \leq \Delta f < 0.8 \text{ MHz}$	$0.015 \text{ MHz} \leq f_{offset} < 0.815 \text{ MHz}$	$P_{rated,c} - 40\text{dB} - \frac{14}{0.8} \left(\frac{f_{offset}}{\text{MHz}} - 0.015 \right) \text{dB}$	30 kHz
	$0.8 \text{ MHz} \leq \Delta f < 1.6 \text{ MHz}$	$0.815 \text{ MHz} \leq f_{offset} < 1.6 \text{ MHz}$	$P_{rated,c} - 54\text{dB} - \frac{5}{0.8} \left(\frac{f_{offset}}{\text{MHz}} - 0.815 \right) \text{dB}$	30 kHz
	$1.6 \text{ MHz} \leq \Delta f < 2.4 \text{ MHz}$	$1.6 \text{ MHz} \leq f_{offset} < 2.4 \text{ MHz}$	$P_{rated,c} - 59\text{dB}$	30 kHz
	$2.4 \text{ MHz} \leq \Delta f < \Delta f_{max}$	$2.4 \text{ MHz} \leq f_{offset} < f_{offsetmax}$	-25dBm	100K

For A-IoT (maximum output power $P_{rated,c} \leq 31$ dBm), emissions shall not exceed the maximum levels specified in Tables 6.5.4.2.3-2.

Table 6.5.4.2.3-2: A-IoT medium range BS operating band unwanted emission limits, BS maximum output power $P_{\text{rated,c}} \leq 31$ dBm

BS R2D channel bandwidth	Frequency offset of measurement filter -3dB point, Δf	Frequency offset of measurement filter centre frequency, f_{offset}	Minimum requirement	Measurement bandwidth
200kHz	$0 \text{ MHz} \leq \Delta f < 0.05 \text{ MHz}$	$0.015 \text{ MHz} \leq f_{\text{offset}} < 0.065 \text{ MHz}$	$\text{Max}(-7\text{dBm} - 60 \cdot \left(\frac{f_{\text{offset}}}{\text{MHz}} - 0.015\right) \text{dB} + X\text{dB}, -27\text{dBm})$	30 kHz
	$0.05 \text{ MHz} \leq \Delta f < 0.15 \text{ MHz}$	$0.065 \text{ MHz} \leq f_{\text{offset}} < 0.165 \text{ MHz}$	$\text{Max}(-10\text{dBm} - 160 \cdot \left(\frac{f_{\text{offset}}}{\text{MHz}} - 0.065\right) \text{dB} + X\text{dB}, -27\text{dBm})$	30 kHz
	$0.15 \text{ MHz} \leq \Delta f < 0.6 \text{ MHz}$	$0.165 \text{ MHz} \leq f_{\text{offset}} < 0.615 \text{ MHz}$	$-27\text{dBm} - \frac{5}{3} \left(\frac{f_{\text{offset}}}{\text{MHz}} - 0.015\right) \text{dB}$	30 kHz
	$0.6 \text{ MHz} \leq \Delta f < 1 \text{ MHz}$	$0.615 \text{ MHz} \leq f_{\text{offset}} < 1.015 \text{ MHz}$	$-22\text{dBm} - 15 \cdot \left(\frac{f_{\text{offset}}}{\text{MHz}} - 0.215\right) \text{dB}$	30 kHz
	$1 \text{ MHz} \leq \Delta f \leq 5 \text{ MHz}$	$1.5 \text{ MHz} \leq f_{\text{offset}} < 5.5 \text{ MHz}$	-21 dBm	1 MHz
	$5 \text{ MHz} \leq \Delta f \leq \Delta f_{\text{max}}$	$5.5 \text{ MHz} \leq f_{\text{offset}} < f_{\text{offsetmax}}$	-25 dBm	1 MHz
400kHz	$0 \text{ MHz} \leq \Delta f < 0.4 \text{ MHz}$	$0.015 \text{ MHz} \leq f_{\text{offset}} < 0.415 \text{ MHz}$	$-9\text{dBm} - \frac{11}{0.4} \left(\frac{f_{\text{offset}}}{\text{MHz}} - 0.015\right) \text{dB}$	30 kHz
	$0.4 \text{ MHz} \leq \Delta f < 0.8 \text{ MHz}$	$0.415 \text{ MHz} \leq f_{\text{offset}} < 0.815 \text{ MHz}$	$-20\text{dBm} - \frac{5}{0.4} \left(\frac{f_{\text{offset}}}{\text{MHz}} - 0.415\right) \text{dB}$	30 kHz
	$0.8 \text{ MHz} \leq \Delta f < 1.6 \text{ MHz}$	$0.815 \text{ MHz} \leq f_{\text{offset}} < 1.6 \text{ MHz}$	-25dBm	30 kHz
	$1.6 \text{ MHz} \leq \Delta f < \Delta f_{\text{max}}$	$1.6 \text{ MHz} \leq f_{\text{offset}} < f_{\text{offsetmax}}$	-25dBm	100kHz
600kHz	$0 \text{ MHz} \leq \Delta f < 0.6 \text{ MHz}$	$0.015 \text{ MHz} \leq f_{\text{offset}} < 0.615 \text{ MHz}$	$-9\text{dBm} - \frac{13}{0.6} \left(\frac{f_{\text{offset}}}{\text{MHz}} - 0.015\right) \text{dB}$	30 kHz
	$0.6 \text{ MHz} \leq \Delta f < 1.2 \text{ MHz}$	$0.615 \text{ MHz} \leq f_{\text{offset}} < 1.2 \text{ MHz}$	$-22\text{dBm} - \frac{5}{0.6} \left(\frac{f_{\text{offset}}}{\text{MHz}} - 0.615\right) \text{dB}$	30 kHz
	$1.2 \text{ MHz} \leq \Delta f < 1.8 \text{ MHz}$	$1.2 \text{ MHz} \leq f_{\text{offset}} < 1.8 \text{ MHz}$	-27dBm	30 kHz
	$1.8 \text{ MHz} \leq \Delta f < \Delta f_{\text{max}}$	$1.8 \text{ MHz} \leq f_{\text{offset}} < f_{\text{offsetmax}}$	-25dBm	100K
800kHz	$0 \text{ MHz} \leq \Delta f < 0.8 \text{ MHz}$	$0.015 \text{ MHz} \leq f_{\text{offset}} < 0.815 \text{ MHz}$	$-9\text{dBm} - \frac{14}{0.8} \left(\frac{f_{\text{offset}}}{\text{MHz}} - 0.015\right) \text{dB}$	30 kHz
	$0.8 \text{ MHz} \leq \Delta f < 1.6 \text{ MHz}$	$0.815 \text{ MHz} \leq f_{\text{offset}} < 1.6 \text{ MHz}$	$-23\text{dBm} - \frac{5}{0.8} \left(\frac{f_{\text{offset}}}{\text{MHz}} - 0.815\right) \text{dB}$	30 kHz
	$1.6 \text{ MHz} \leq \Delta f < 2.4 \text{ MHz}$	$1.6 \text{ MHz} \leq f_{\text{offset}} < 2.4 \text{ MHz}$	-28dBm	30 kHz
	$2.4 \text{ MHz} \leq \Delta f < \Delta f_{\text{max}}$	$2.4 \text{ MHz} \leq f_{\text{offset}} < f_{\text{offsetmax}}$	-25dBm	100kHz

6.5.4.3 Minimum requirements for BS type 1-C

The operating band unwanted emissions for BS type 1-C for each antenna connector shall be below the applicable basic limits defined in clause 6.5.4.2.

6.5.5 Transmitter spurious emissions

6.5.5.1 General

The transmitter spurious emission limits shall apply from 9 kHz to 12.75 GHz, excluding the frequency range from 10MHz below the lowest frequency of each supported downlink operating band, up to 10MHz above the highest frequency of each supported downlink operating band.

Unless otherwise stated, all requirements are measured as mean power (RMS).

6.5.5.2 Basic limits

6.5.5.2.1 General transmitter spurious emissions requirements

The basic limits of either table 6.5.5.2.1-1 (Category A limits) or table 6.5.5. 2.1-2 (Category B limits) shall apply.

Table 6.5.5.2.1-1: General BS transmitter spurious emission limits in FR1, Category A

Spurious frequency range	Basic limit	Measurement bandwidth
9 kHz – 150 kHz	-13 dBm	1 kHz
150 kHz – 30 MHz		10 kHz
30 MHz – 1 GHz		100 kHz
1 GHz – 12.75 GHz		1 MHz

Table 6.5.5.2.1-2: General BS transmitter spurious emission limits in FR1, Category B

Spurious frequency range	Basic limit	Measurement bandwidth
9 kHz – 150 kHz	-36 dBm	1 kHz
150 kHz – 30 MHz		10 kHz
30 MHz – 1 GHz		100 kHz
1 GHz – 12.75 GHz	-30 dBm	1 MHz

6.5.5.2.2 Additional spurious emissions requirements

These requirements may be applied for the protection of system operating in frequency ranges other than the BS downlink operating band. The limits may apply as an optional protection of such systems that are deployed in the same geographical area as the BS, or they may be set by local or regional regulation as a mandatory requirement for an NR operating band. It is in some cases not stated in the present document whether a requirement is mandatory or under what exact circumstances that a limit applies, since this is set by local or regional regulation. An overview of regional requirements in the present document is given in clause 4.5.

Some requirements may apply for the protection of specific equipment (UE, MS and/or BS) or equipment operating in specific systems (GSM, CDMA, UTRA, E-UTRA, NR, etc.) as listed below.

The spurious emission *basic limits* are provided in table 6.5.5.2.2 -1 for a BS where requirements for co-existence with the system listed in the first column apply.

Table 6.5.5.2.2-1: BS spurious emissions *basic limits* for BS for co-existence with systems operating in other frequency bands

System type for A-IoT to co-exist with (Note 7)	Frequency range for co-existence requirement (MHz) (Note 8)	Basic limits (dBm)	Measurement bandwidth	Notes
GSM850 or CDMA850	869 - 894	-57	100 kHz	Note 1
	824 - 849	-61		
GSM900	921 - 960	-57		
	876 - 915	-61		
DCS1800	1805 - 1880	-47		
	1710 - 1785	-61		
PCS1900	1930 - 1990	-47		
	1850 - 1910	-61		
UTRA, E-UTRA or NR	Frequency range of downlink <i>operating band</i> of the BS to co-exist with	-52	1 MHz	Note 1, Note 9
	Frequency range of uplink <i>operating band</i> of the BS to co-exist with	-49		

NOTE 1: As defined in the scope for spurious emissions in this clause, except for the cases where the noted requirements apply to a BS operating in Band n28, the co-existence requirements in table 6.5.5.2.2-1 do not apply for the 10MHz frequency range immediately outside the downlink *operating band* (see table 5.2-1). Emission limits for this excluded frequency range may be covered by local or regional requirements.

NOTE 2: Table 6.5.5.2.2-1 assumes that two *operating bands*, where the frequency ranges in table 5.2-1 would be overlapping, are not deployed in the same geographical area. For such a case of operation with overlapping frequency arrangements in the same geographical area, special co-existence requirements may apply that are not covered by the 3GPP specifications.

NOTE 3: TDD base stations deployed in the same geographical area, that are synchronized and use the same or adjacent *operating bands* can transmit without additional co-existence requirements. For unsynchronized base stations, special co-existence requirements may apply that are not covered by the 3GPP specifications.

NOTE 4: For NR Band n28 BS, specific solutions may be required to fulfil the spurious emissions limits for BS for co-existence with E-UTRA Band 27 UL *operating band*, where requirement applies 4 MHz above the Band n28 downlink operating band.

NOTE 5: For NR Band n29 BS, specific solutions may be required to fulfil the spurious emissions limits for NR BS for co-existence with UTRA Band XII, E-UTRA Band 12 or NR Band n12 UL operating band, E-UTRA Band 17 UL operating band or E-UTRA Band 85 UL or NR Band n85 UL operating band, where requirement applies 1 MHz below the Band n29 downlink operating band.

NOTE 6: For NR Band n67 BS, specific solutions may be required to fulfil the spurious emissions limits for NR BS co-existence with E-UTRA Band 28 or NR Band n28 UL operating band or NR Band n83 UL operating band, where requirement applies for 703 MHz to 736 MHz.

NOTE 7: Does not apply for co-existence with standalone downlink bands (SDO) defined in TS 36.104 [9], table 5.5-1.

NOTE 8: Frequency range of UTRA, E-UTRA and NR bands, as described in TS 25.104 [8] clause 5.2, TS 36.104 [9] clause 5.5 and TS 38.104 [10] clause 5.2, respectively.

NOTE 9: For TDD bands, -52 dBm/MHz basic limit applies.

Table 6.5.5.2.3-3: Void

6.5.5.2.3 Co-location with other base stations

These requirements may be applied for the protection of other BS receivers when GSM900, DCS1800, PCS1900, GSM850, CDMA850, UTRA FDD, UTRA TDD, E-UTRA and/or NR BS are co-located with a BS.

The requirements assume a 30 dB coupling loss between transmitter and receiver and are based on co-location with base stations of the same class.

The *basic limits* are in table 6.5.5.2.3-1 for a BS where requirements for co-location with a BS type listed in the second column apply, depending on the declared Base Station class.

Table 6.5.5.2.3-1: BS spurious emissions *basic limits* for BS co-located with another BS

Frequency range of uplink operating band of the co-located BS (MHz) (Note 4)	System type to co-locate with	<i>Basic limits</i> (dBm/100kHz) (Note 1)
		MR BS
824 - 849	GSM850 or CDMA850	-91
876 - 915	GSM900	-91
1710 - 1785	DCS1800	-91
1850 - 1910	PCS1900	-91
49, 51/n51, n91, n93	E-UTRA or NR	N/A
46/n46, 53/n53	E-UTRA or NR	-91
n100, n101	NR	N/A
n96, n102	NR	-90
n104	NR	-90
Other operating band	UTRA, E-UTRA or NR	-91

NOTE 1: As defined in the scope for spurious emissions in this clause, the co-location requirements in table 6.5.5.2.3-1 do not apply for the frequency range extending 10MHz immediately outside the BS transmit frequency range of a downlink *operating band* (see table 5.2-1). The current state-of-the-art technology does not allow a single generic solution for co-location with other system on adjacent frequencies for 30dB BS-BS minimum coupling loss. However, there are certain site-engineering solutions that can be used. These techniques are addressed in TR 25.942 [4].

NOTE 2: Table 6.5.5.2.3-1 assumes that two *operating bands*, where the corresponding BS transmit and receive frequency ranges in table 5.2-1 would be overlapping, are not deployed in the same geographical area. For such a case of operation with overlapping frequency arrangements in the same geographical area, special co-location requirements may apply that are not covered by the 3GPP specifications.

NOTE 3: Co-located TDD base stations that are synchronized and using the same or adjacent *operating band* can transmit without special co-locations requirements. For unsynchronized base stations, special co-location requirements may apply that are not covered by the 3GPP specifications.

NOTE 4: Frequency range of UTRA, E-UTRA and NR bands, as described in TS 25.104 [7] clause 5.2, TS 36.104 [9] clause 5.5 and TS 38.104 [10] clause 5.2, respectively.

6.5.5.3 Minimum requirements for *BS type 1-C*

The Tx spurious emissions for BS type 1-C for each antenna connector shall not exceed the basic limits specified in clause 6.5.5.2.

7 A-IoT BS receiver characteristics

7.1 General

Conducted receiver characteristics are specified at the *antenna connector* for *BS type 1-C*, with full complement of transceivers for the configuration in normal operating condition.

Unless otherwise stated, the following arrangements apply for conducted receiver characteristics requirements in clause 7:

- Requirements apply during the BS receive period.
- Reference requirements defined for the conducted receiver characteristics do not assume HARQ retransmissions.

NOTE 1: In normal operating condition, A-IoT BS is configured as HD-FDD operation.

7.2 Reference sensitivity level

7.2.1 General

The reference sensitivity power level P_{REFSENS} is the minimum mean power received at the *antenna connector* for *BS type 1-C* at which a BLER requirement shall be met for a specified reference measurement channel.

7.2.2 Minimum requirements for *BS type 1-C*

The BLER shall be less than or equal to 10% of the reference measurement channel as specified in annex A.1 with parameters specified in table 7.2.2-1 for A-IoT Medium range BS.

Table 7.2.2-1: A-IoT Medium range BS reference sensitivity levels

<i>BS D2R channel bandwidth for RX requirements definition (kHz)</i>	<i>Nominal D2R transmission bandwidth without SFO (kHz)</i>	<i>Reference measurement channel</i>	<i>Reference sensitivity power level, P_{REFSENS} (dBm)</i>
200	15	A-FR1-A1-1	-95.2
		A-FR1-A1-2	-92.2
3520	2880	A-FR1-A1-3	-72.4
		A-FR1-A1-4	-69.4

NOTE: Reference sensitivity power level is defined based on the CW power at the BS antenna connector as -38dBm without the cancellation of CW phase noise considered.

7.3 In-band selectivity and blocking

7.3.1 Adjacent Channel Selectivity

7.3.1.1 General

Adjacent channel selectivity (ACS) is a measure of the receiver's ability to receive a wanted signal at its assigned channel frequency at the *antenna connector* for *BS type 1-C* in the presence of an adjacent channel signal with a specified centre frequency offset of the interfering signal to the band edge of a victim system.

7.3.1.2 Minimum requirement for *BS type 1-C*

The BLER shall be 10% of the reference measurement channel as specified in annex A.1.

The wanted and the interfering signal coupled to the *BS type 1-C antenna connector* are specified in table 7.3.1.2-1 and the frequency offset between the wanted and interfering signal in table 7.3.1.2-2 for ACS. The reference measurement channel for the wanted signal is identified in table 7.2.2-1, 7.2.2-2 and 7.2.2-3 for each *BS D2R channel bandwidth* in any operating band and further specified in annex A.1. The characteristics of the interfering signal is further specified in annex D.

The ACS requirement is applicable outside the *Base Station RF Bandwidth* or *Radio Bandwidth*. The interfering signal offset is defined relative to the *Base station RF Bandwidth* edges or *Radio Bandwidth* edges.

Minimum conducted requirement is defined at the *antenna connector* for *BS type 1-C*.

Table 7.3.1.2-1: Base station ACS requirement

<i>BS D2R channel bandwidth for RX requirements definition of the lowest/highest carrier received [kHz]</i>	<i>Wanted signal mean power [dBm]</i>	<i>Interfering signal mean power [dBm]</i>	<i>Interfering signal centre frequency offset to the lower/upper Base Station RF Bandwidth edge [kHz]</i>	<i>Type of interfering signal</i>
200	$P_{\text{REFSENS}} + 6\text{dB}$ (Note)	-53	± 340	5 MHz DFT-s-OFDM NR signal, 15 kHz SCS, 1 RB, closest to wanted signal
3520	$P_{\text{REFSENS}} + 6\text{dB}$ (Note)	-53	± 2500	5 MHz DFT-s-OFDM NR signal

Note: P_{REFSENS} depends on the sub-carrier spacing as specified in Table 7.2.2-1

Table 7.3.1.2-2: Base Station ACS interferer frequency offset values

<i>BS D2R channel bandwidth for Rx requirements definition of the lowest/highest carrier received (kHz)</i>	<i>Interfering signal centre frequency offset from the lower/upper Base Station RF Bandwidth edge (kHz)</i>	<i>Type of interfering signal</i>
200	± 340	5 MHz DFT-s-OFDM NR signal, 15 kHz SCS, 1 RB, closest to wanted signal
3520	± 2500	5 MHz DFT-s-OFDM NR signal

7.3.2 In-band blocking

7.3.2.1 General

The in-band blocking characteristics is a measure of the receiver's ability to receive a wanted signal at its assigned channel at the *antenna connector* for *BS type 1-C* in the presence of an unwanted interferer, which is an NR signal for general blocking or an NR signal with one resource block for narrowband blocking.

7.3.2.2 Minimum requirement for *BS type 1-C*

The BLER performance shall be 10% of the reference measurement channel as specified in annex A.1, with a wanted and an interfering signal coupled to *BS type 1-C antenna connector* using the parameters in tables 7.3.2.2-1 for general blocking. The reference measurement channel for the wanted signal is identified in clause 7.2.2 for each *BS channel bandwidth* and further specified in annex A.1. The characteristics of the interfering signal is further specified in annex D.

The in-band blocking requirements apply outside the *Base Station RF Bandwidth* or *Radio Bandwidth*. The interfering signal offset is defined relative to the *Base Station RF Bandwidth* edges or *Radio Bandwidth* edges.

The in-band blocking requirement shall apply from $F_{UL,low} - \Delta f_{OOB}$ to $F_{UL,high} + \Delta f_{OOB}$, excluding the downlink frequency range of the FDD *operating band*. The Δf_{OOB} for *BS type 1-C* is defined in table 7.3.2.2-0.

Minimum conducted requirement is defined at the *antenna connector* for *BS type 1-C*.

Table 7.3.2.2-0: Δf_{OOB} offset for NR *operating bands*

BS type	Operating band characteristics	Δf_{OOB} (MHz)
BS type 1-C	$F_{UL,high} - F_{UL,low} \leq 200$ MHz	20
	$200 \text{ MHz} < F_{UL,high} - F_{UL,low} \leq 900$ MHz	60

Table 7.3.2.2-1: Base station general blocking requirement

BS D2R channel bandwidth for RX requirements definition of the lowest/highest carrier received (kHz)	Wanted signal mean power (dBm) (Note 2)	Interfering signal mean power (dBm)	Interfering signal centre frequency minimum offset from the lower/upper Base Station RF Bandwidth edge (MHz)	Type of interfering signal
200	$P_{REFSENS} + 6$ dB	-38	± 7.5	5MHz DFT-s-OFDM NR signal 15 kHz SCS, 25 RBs
3520	$P_{REFSENS} + 6$ dB	-38	± 7.5	5 MHz DFT-s-OFDM NR signal 15 kHz SCS, 25 RBs

NOTE 1: $P_{REFSENS}$ depends also on the *BS channel bandwidth* as specified in tables 7.2.2-1

7.4 Out-of-band blocking

7.4.1 General

The out-of-band blocking characteristics is a measure of the receiver ability to receive a wanted signal at its assigned channel at the *antenna connector* for *BS type 1-C* in the presence of an unwanted interferer out of the *operating band*, which is a CW signal for out-of-band blocking.

7.4.2 Minimum requirement for *BS type 1-C*

the MDR performance shall be [1%] of the reference measurement channel, with a wanted and an interfering signal coupled to *BS type 1-C antenna connector* using the parameters in table 7.5.2-1.

The reference measurement channel for the wanted signal is identified in clause 7.2.2 for each *BS channel bandwidth* and further specified in annex A.1. The characteristics of the interfering signal is further specified in annex D.

The out-of-band blocking requirement apply from 1 MHz to $F_{UL,low} - \Delta f_{OOB}$ and from $F_{UL,high} + \Delta f_{OOB}$ up to 12750 MHz, including the downlink frequency range of the FDD *operating band* for BS supporting FDD. The Δf_{OOB} for *BS type 1-C* is defined in table 7.4.2.2-0.

Minimum conducted requirement is defined at the *antenna connector* for *BS type 1-C*.

Table 7.4.2-1: Out-of-band blocking performance requirement for NR

Wanted Signal mean power (dBm)	Interfering Signal mean power (dBm)	Type of Interfering Signal
$P_{\text{REFSENS}} + 6$ dB (Note)	-15	CW carrier
NOTE : P_{REFSENS} depends also on the BS channel bandwidth as specified in Table 7.2.2-1.		

7.5 Receiver spurious emissions

7.5.1 General

The receiver spurious emissions power is the power of emissions generated or amplified in a receiver unit that appear at the *antenna connector* (for BS type 1-C). The requirements apply to all BS with separate RX and TX *antenna connectors*.

NOTE: In this case for FDD operation the test is performed when both TX and RX are ON, with the TX *antenna connectors* terminated.

For *antenna connectors* supporting both RX and TX in FDD, the RX spurious emissions requirements are superseded by the TX spurious emissions requirements, as specified in clause 6.6.5.

7.5.2 Basic limits

The receiver spurious emissions *basic limits* are provided in table 7.6.2-1.

Table 7.5.2-1: General BS receiver spurious emissions limits

Spurious frequency range	Basic limits	Measurement bandwidth	Note
30 MHz – 1 GHz	-57 dBm	100 kHz	Note 1
1 GHz – 12.75 GHz	-47 dBm	1 MHz	Note 1, Note 2
12.75 GHz – 5 th harmonic of the upper frequency edge of the UL <i>operating band</i> in GHz	-47 dBm	1 MHz	Note 1, Note 2, Note 3
12.75 GHz - 26 GHz	-47 dBm	1 MHz	Note 1, Note 2, Note 5
NOTE 1: <i>Measurement bandwidths</i> as in ITU-R SM.329 [2], s4.1.			
NOTE 2: Upper frequency as in ITU-R SM.329 [2], s2.5 table 1.			
NOTE 3: Applies for Band for which the upper frequency edge of the UL <i>operating band</i> is greater than 2.55 GHz and less than or equal to 5.2 GHz.			
NOTE 4: The frequency range from Δf_{OBUE} below the lowest frequency of the BS transmitter <i>operating band</i> to Δf_{OBUE} above the highest frequency of the BS transmitter <i>operating band</i> may be excluded from the requirement. Δf_{OBUE} is defined in clause 6.6.1. For <i>multi-band connectors</i> , the exclusion applies for all supported <i>operating bands</i> .			
NOTE 5: Applies for Band for which the upper frequency edge of the UL <i>operating band</i> is greater than 5.2 GHz.			

7.5.3 Minimum requirement for BS type 1-C

The RX spurious emissions requirements for BS type 1-C are that for each *antenna connector*, the power of emissions shall not exceed *basic limits* specified in table 7.6.2-1.

7.6 Receiver intermodulation

7.6.1 General

Third and higher order mixing of the two interfering RF signals can produce an interfering signal in the band of the desired channel. Intermodulation response rejection is a measure of the capability of the receiver to receive a wanted signal on its assigned channel frequency at the *antenna connector* for *BS type 1-C* in the presence of two interfering signals which have a specific frequency relationship to the wanted signal.

7.6.2 Minimum requirement for BS type 1-C

The BLER performance shall be 10% of the reference measurement channel as specified in annex A.1, with a wanted signal at the assigned channel frequency and two interfering signals coupled to the *BS type 1-C antenna connector*, with the conditions specified in tables 7.6.2-1 for narrowband intermodulation performance. The reference measurement channel for the wanted signal is identified in tables 7.2.2-1 for each *BS channel bandwidth* and further specified in annex A.1. The characteristics of the interfering signal is further specified in annex D.

The receiver intermodulation requirement is applicable outside the *Base Station RF Bandwidth* or *Radio Bandwidth edges*. The interfering signal offset is defined relative to the *Base Station RF Bandwidth edges* or *Radio Bandwidth edges*.

Table 7.6.2-1: Narrowband intermodulation performance requirement for A-IoT Medium Range BS

BS D2R Channel bandwidth for RX requirements definition of the lowest/highest carrier received [kHz]	Wanted signal mean power [dBm]	Interfering signal mean power [dBm]	Interfering RB centre frequency offset from the lower/upper Base Station RF Bandwidth edge [kHz]	Type of interfering signal
200	P _{PREFSENS} + 6dB (Note 1)	-53	±340	CW
		-53	±780	5 MHz NRsignal, 1 RB (Note 2)
3520	P _{PREFSENS} + 6dB (Note 1)	-53	±270	CW
		-53	±2300	5 MHz NR signal, 1 RB (Note 2)
NOTE 1: P _{PREFSENS} depends on the sub-carrier spacing as specified in Table 7.2.2-1.				
NOTE 2: Interfering signal consisting of one resource block positioned at the stated offset, the channel bandwidth of the interfering signal is located adjacently to the lower/upper Base Station RF Bandwidth edge.				

8 A-IoT CW transmitter characteristics

8.1 General

Unless otherwise stated, the transmitter characteristics are specified at the antenna connector of the CW node with a single or multiple transmit antenna(s). The CW waveform for D2R backscattering is a single-tone unmodulated sinusoid.

NOTE: CW transmission and A-IoT BS Downlink (DL) data transmission are non-concurrent. For FDD bands, the CW is transmitted in Uplink (UL) operating band.

8.2 CW Output power

8.2.1 General

Output power of the CW node is the mean power of the single-tone signal delivered to a load with resistance equal to the nominal load impedance of the transmitter.

Rated total output power (P_{rated}) of the CW node is the mean power of the single-tone signal that the manufacturer has declared to be available at the antenna connector during the transmitter ON period. The rated output power, P_{rated} , of the CW node shall be less than or equal to +33 dBm.

Maximum output power (P_{max}) of the base station is the mean power level of the single-tone signal measured at the antenna connector during the transmitter ON period in a specified reference condition.

8.2.2 Minimum requirement

In normal conditions, the CW maximum output power, P_{max} , shall remain within +2 dB and -2 dB of the rated output power, P_{rated} , declared by the manufacturer.

In extreme conditions, the base station maximum output power, P_{max} , shall remain within +2.5 dB and -2.5 dB of the rated output power, P_{rated} , declared by the manufacturer.

In certain regions, the minimum requirement for normal conditions may apply also for some conditions outside the range of conditions defined as normal.

8.3 Frequency error

8.3.1 General

The requirements in clause 8.3 apply to the *transmitter ON period*.

Frequency error is the measure of the difference between the actual carrier wave transmit frequency and the assigned frequency. This requirement shall be applied at the *antenna connector* supporting transmission in the *operating band*.

8.3.2 Minimum requirement

The frequency of carrier wave measurements shall be accurate to within ± 0.1 ppm observed over a period of 1 ms compared to the carrier frequency declared by the manufacturer.

8.4 Transmit OFF power

8.4.1 General

Transmit OFF power is defined as the mean power when the transmitter is OFF.

8.4.2 Minimum requirement

The transmit OFF power shall not exceed -50 dBm/MHz

8.5 Unwanted emission

8.5.1 General

Unwanted emissions consist of phase noise, operating band unwanted emissions and spurious emissions.

Unless otherwise stated, all requirements are measured as mean power (RMS).

8.5.2 Phase noise

8.5.2.1 General

The phase noise is the unwanted emissions outside the centre frequency of carrier wave resulting from random fluctuations in the phase of signal in the transmitter but excluding spurious emissions. The phase noise of the CW applies to ± 7.5 kHz and ± 120 kHz frequency offset (Δf) from centre frequency of carrier wave.

For the CW equipment declared capable of performing phase noise cancellation, the requirement in 8.5.2.2 is not applied.

8.5.2.2 Minimum requirement

The phase noise power of CW transmitter shall not exceed the levels specified in Table 8.5.2.2-1

Table 8.5.2.2-1: CW phase noise emission limit

Δf (kHz)	Phase noise emission limit (dBc/Hz)
± 7.5	-97
± 120	-102

8.5.3 Operating band unwanted emissions

8.5.3.1 General

Unless otherwise stated, the operating band unwanted emission (OBUE) limits in FR1 are defined from 10 MHz below the lowest frequency of each supported uplink *operating band* up to 10 MHz above the highest frequency of each supported uplink *operating band*.

Emissions shall not exceed the maximum levels specified in the tables below, where:

- Δf is the separation between the assigned transmission frequency and the nominal -3dB point of the measuring filter closest to the carrier frequency.

8.5.3.2 Minimum requirement

The operating band unwanted emissions shall not exceed the maximum levels specified in the Table 8.5.2.2-1. The spectrum emission limit between each Δf is linearly interpolated.

Table 8.5.3.2-1: CW node Operating band unwanted emissions

Δf (kHz)	Emission limit (dBm)	Measurement bandwidth
± 200	-18	30 kHz
± 250	-20	30 kHz
± 350	-25	30 kHz
± 800	-26	30 kHz
± 1200	-19	1 MHz
$\pm 5200\sim 10000$	-23	1 MHz

8.5.4 Transmitter spurious emissions

8.5.4.1 General

The transmitter spurious emission limits shall apply from 9 kHz to 12.75 GHz, excluding the frequency range from 10MHz below the lowest frequency of each supported uplink *operating band*, up to 10 MHz above the highest frequency of each supported uplink *operating band*.

8.5.4.2 Minimum requirement

The power of any spurious emission shall not exceed the limits in Table 8.5.4.2-1.

Table 8.5.4.2-1: Spurious emissions limits

Frequency Range	Maximum Level	Measurement bandwidth
$9 \text{ kHz} \leq f < 150 \text{ kHz}$	-36 dBm	1 kHz
$150 \text{ kHz} \leq f < 30 \text{ MHz}$	-36 dBm	10 kHz
$30 \text{ MHz} \leq f < 1000 \text{ MHz}$	-36 dBm	100 kHz
$1 \text{ GHz} \leq f < 12.75 \text{ GHz}$	-30 dBm	1 MHz

Annex A (informative): D2R channel bandwidth

The following describes the equation to derive BS D2R channel bandwidth.

For BS D2R CBW:

$$\begin{aligned} & \text{D2R CBW for BS (kHz)} \\ &= \text{ceiling} ((2\text{SB Transmission BW_without SFO} \times (1/2) + 2 \times \text{Small frequency shift_without SFO}) / 0.9) \\ &= \text{ceiling} ((2+2R) / T_b \times (1 + |\text{SFO}|) / 0.9) \\ &= \text{ceiling} ((1+R) / (T_c \times R) \times (1 + |\text{SFO}|) / 0.9) \end{aligned}$$

The 0.9 divisor presents the 90% BS filter spectrum utility (10% guard band).

Annex B (normative): Reference measurement channels

B.1 Fixed Reference Channels for reference sensitivity level, ACS, in-band blocking, out-of-band blocking, (BPSK, OOK)

Reference channel	A-FR1-A1-1	A-FR1-A1-2	A-FR1-A1-3	A-FR1-A1-4
DSB (kHz)	15	15	2880	2880
Payload size (bits)	96	96	96	96
CRC (bits)	16	16	16	16
Preamble length	31	31	31	31
Midamble length	31	31	31	31
Midamble configuration I	48	48	48	48
FEC	1/3	1/3	1/3	1/3
Line code	Manchester	Manchester	Manchester	Manchester
Modulation	BPSK	OOK	BPSK	OOK
Waveform (CW)	unmodulated single tone	Unmodulated single tone	unmodulated single tone	unmodulated single tone
Sampling frequency (SFO)	between 0.01 and 0.1	Between 0.01 and 0.1	between 0.01 and 0.1	Between 0.01 and 0.1
Total symbols	398	398	398	398

B.2 Fixed Reference Channels for R2D Tx requirements

Component	Parameter	Unit	Value			
			A-FR1-B1-1	A-FR1-B1-2	A-FR1-B1-3	A-FR1-B1-4
General	PRB	RBs	1	2	3	4
	SCS	kHz	15	15	15	15
SIP	Bit length	Bits	8	8	8	8
	Mapping to OFDM	Chips/Symbol	4	4	4	4
CAP	Bit length	Bits	4	4	4	4
	M	Chips/Symbol	6	12	24	24
PRDCH	TBS	Bits	96	96	96	96
	CRC	Bits	16	16	16	16
	M	Chips/Symbol	6	12	24	24
Postamble	Bit length	Bits	4	4	4	4
	M	Chips/Symbol	6	12	24	24
Padding	Padding for last OFDM symbol	Chips	2	8	8	8

Annex C (normative): Characteristics of the interfering signals

The interfering signal shall be a PUSCH containing data and DM-RS symbols. Normal cyclic prefix is used. The data content shall be uncorrelated to the wanted signal and modulated according to clause 6 of TS38.211 [5]. Mapping of PUSCH modulation to receiver requirement are specified in table C-1.

Table C-1: Modulation of the interfering signal

Receiver requirement	Modulation
Adjacent channel selectivity	QPSK
General blocking	QPSK
Receiver intermodulation	QPSK

Annex D (Informative): Change history

Change history							
Date	Meeting	TDoc	CR	Rev	Cat	Subject/Comment	New version
2025-04	RAN4#114 bis	R4-2505228				3GPP_TS 38.194 skeleton	0.0.1
2025-08	RAN4#116	R4-2511749				Agreed TP in RAN4#116: R4-2511722 TP for TR 38.194 5.3 BS channel bandwidth and 5.4 Channel arrangement R4-2511723 TP for TR 38.191 section 3 Definitions, symbols and abbreviations R4-2511725 draft TP for TS 38.194 to introduce base station output power and transmit ON/OFF power R4-2511727 TP for TR 38.194 6.5 Unwanted emissions and 6.6 Transmitter intermodulation R4-2511728 draft TP to TS 38.194 on Transmitted signal quality R4-2511731 TP to TS38.194: REFSSENS requirement for A-IoT BS and FRC R4-2511732 TP to TS38.194 : ACS , Inband blocking, OOB and Spurious R4-2511742 TP to TS 38.194 on CW frequency error and unwanted emission R4-2511743 TP to 38.194 on general and CW output power	0.0.2
2025-09	RAN#109	RP-252745					1.0.0

Change history							
Date	Meeting	TDoc	CR	Rev	Cat	Subject/Comment	New version
2025-09	RAN#109					Approved by plenary – Rel-19 spec under change control	19.0.0
2025-12	RAN#110	RP-253654	0003		F	CR for TS 38.194, Correction on A-IoT BS Annex	19.1.0
2025-12	RAN#110	RP-253844	0006	4	B	CR for TS 38.194 on including n5 and n28 for A-IoT [Ambient_IoT_n5_n28]	19.1.0
2025-12	RAN#110	RP-253654	0004	1	F	CR for TS 38.194, Correction on A-IoT BS requirements. Note: CR was not implemented due to massive CR clashes of R4-2522325 and R4-2523216 in RP-253654.	19.1.0
2025-12	RAN#110	RP-253654	0005	3	F	CR for TS 38.194 on A-IoT BS RF requirements Note: CR was not implemented due to massive CR clashes of R4-2522325 and R4-2523216 in RP-253654.	19.1.0
2026-03	RAN#111	RP-260443	0008		F	CR for TS 38.194, Correction on A-IoT BS Tx requirements	19.2.0
2026-03	RAN#111	RP-260443	0010		F	CR for TS 38.194, Correction on A-IoT BS Rx requirements	19.2.0
2026-03	RAN#111	RP-260443	0007	1	F	(Ambient_IoT_Solutions-Core)CR for 38.194, on framework simplification for co-location/co-existence requirement	19.2.0
2026-03	RAN#111	RP-260443	0009	1	F	CR for TS 38.194 on A-IoT BS RF requirements	19.2.0

History

Version	Date	Status
V19.0.0	October 2025	Publication
V19.1.0	February 2026	Publication
V19.2.0	April 2026	Publication