

ETSI TS 138 202 V18.3.0 (2024-08)



**5G;
NR;
Services provided by the physical layer
(3GPP TS 38.202 version 18.3.0 Release 18)**



Reference

RTS/TSGR-0138202vi30

Keywords

5G

ETSI

650 Route des Lucioles
F-06921 Sophia Antipolis Cedex - FRANCE

Tel.: +33 4 92 94 42 00 Fax: +33 4 93 65 47 16

Siret N° 348 623 562 00017 - APE 7112B
Association à but non lucratif enregistrée à la
Sous-Préfecture de Grasse (06) N° w061004871

Important notice

The present document can be downloaded from the
ETSI [Search & Browse Standards application](#).

The present document may be made available in electronic versions and/or in print. The content of any electronic and/or print versions of the present document shall not be modified without the prior written authorization of ETSI. In case of any existing or perceived difference in contents between such versions and/or in print, the prevailing version of an ETSI deliverable is the one made publicly available in PDF format on [ETSI deliver](#).

Users should be aware that the present document may be revised or have its status changed,
this information is available in the [Milestones listing](#).

If you find errors in the present document, please send your comments to
the relevant service listed under [Committee Support Staff](#).

If you find a security vulnerability in the present document, please report it through our
[Coordinated Vulnerability Disclosure \(CVD\)](#) program.

Notice of disclaimer & limitation of liability

The information provided in the present deliverable is directed solely to professionals who have the appropriate degree of experience to understand and interpret its content in accordance with generally accepted engineering or other professional standard and applicable regulations.

No recommendation as to products and services or vendors is made or should be implied.

No representation or warranty is made that this deliverable is technically accurate or sufficient or conforms to any law and/or governmental rule and/or regulation and further, no representation or warranty is made of merchantability or fitness for any particular purpose or against infringement of intellectual property rights.

In no event shall ETSI be held liable for loss of profits or any other incidental or consequential damages.

Any software contained in this deliverable is provided "AS IS" with no warranties, express or implied, including but not limited to, the warranties of merchantability, fitness for a particular purpose and non-infringement of intellectual property rights and ETSI shall not be held liable in any event for any damages whatsoever (including, without limitation, damages for loss of profits, business interruption, loss of information, or any other pecuniary loss) arising out of or related to the use of or inability to use the software.

Copyright Notification

No part may be reproduced or utilized in any form or by any means, electronic or mechanical, including photocopying and microfilm except as authorized by written permission of ETSI.

The content of the PDF version shall not be modified without the written authorization of ETSI.

The copyright and the foregoing restriction extend to reproduction in all media.

© ETSI 2024.
All rights reserved.

Intellectual Property Rights

Essential patents

IPRs essential or potentially essential to normative deliverables may have been declared to ETSI. The declarations pertaining to these essential IPRs, if any, are publicly available for **ETSI members and non-members**, and can be found in ETSI SR 000 314: "*Intellectual Property Rights (IPRs); Essential, or potentially Essential, IPRs notified to ETSI in respect of ETSI standards*", which is available from the ETSI Secretariat. Latest updates are available on the ETSI Web server (<https://ipr.etsi.org/>).

Pursuant to the ETSI Directives including the ETSI IPR Policy, no investigation regarding the essentiality of IPRs, including IPR searches, has been carried out by ETSI. No guarantee can be given as to the existence of other IPRs not referenced in ETSI SR 000 314 (or the updates on the ETSI Web server) which are, or may be, or may become, essential to the present document.

Trademarks

The present document may include trademarks and/or tradenames which are asserted and/or registered by their owners. ETSI claims no ownership of these except for any which are indicated as being the property of ETSI, and conveys no right to use or reproduce any trademark and/or tradename. Mention of those trademarks in the present document does not constitute an endorsement by ETSI of products, services or organizations associated with those trademarks.

DECT™, **PLUGTESTS™**, **UMTS™** and the ETSI logo are trademarks of ETSI registered for the benefit of its Members. **3GPP™** and **LTE™** are trademarks of ETSI registered for the benefit of its Members and of the 3GPP Organizational Partners. **oneM2M™** logo is a trademark of ETSI registered for the benefit of its Members and of the oneM2M Partners. **GSM®** and the GSM logo are trademarks registered and owned by the GSM Association.

Legal Notice

This Technical Specification (TS) has been produced by ETSI 3rd Generation Partnership Project (3GPP).

The present document may refer to technical specifications or reports using their 3GPP identities. These shall be interpreted as being references to the corresponding ETSI deliverables.

The cross reference between 3GPP and ETSI identities can be found under <https://webapp.etsi.org/key/queryform.asp>.

Modal verbs terminology

In the present document "**shall**", "**shall not**", "**should**", "**should not**", "**may**", "**need not**", "**will**", "**will not**", "**can**" and "**cannot**" are to be interpreted as described in clause 3.2 of the [ETSI Drafting Rules](#) (Verbal forms for the expression of provisions).

"**must**" and "**must not**" are **NOT** allowed in ETSI deliverables except when used in direct citation.

Contents

Intellectual Property Rights	2
Legal Notice	2
Modal verbs terminology.....	2
Foreword.....	4
1 Scope	5
2 References	5
3 Definitions of terms, symbols and abbreviations	5
3.1 Terms.....	5
3.2 Symbols.....	5
3.3 Abbreviations	5
4 Services and functions of the physical layer	6
4.1 General	6
4.2 Overview of L1 functions.....	6
5 Model of physical layer of the UE	7
5.1 Uplink model.....	7
5.1.1 Uplink shared channel	7
5.1.2 Random access channel	8
5.2 Downlink model.....	8
5.2.1 Downlink shared channel.....	8
5.2.2 Broadcast channel.....	8
5.2.3 Paging channel.....	9
5.3 Sidelink model.....	10
5.3.1 Sidelink shared channel	10
5.3.2 Broadcast channel.....	11
6 Simultaneous transmission and reception of physical channels and physical signals.....	12
6.1 Uplink.....	12
6.2 Downlink.....	13
6.3 Sidelink	15
7 Measurements provided by the physical layer	17
7.1 UE measurements.....	17
Annex A (informative): Change history	18
History	21

Foreword

This Technical Specification has been produced by the 3rd Generation Partnership Project (3GPP).

The contents of the present document are subject to continuing work within the TSG and may change following formal TSG approval. Should the TSG modify the contents of the present document, it will be re-released by the TSG with an identifying change of release date and an increase in version number as follows:

Version x.y.z

where:

- x the first digit:
 - 1 presented to TSG for information;
 - 2 presented to TSG for approval;
 - 3 or greater indicates TSG approved document under change control.
- y the second digit is incremented for all changes of substance, i.e. technical enhancements, corrections, updates, etc.
- z the third digit is incremented when editorial only changes have been incorporated in the document.

1 Scope

The present document is a technical specification of the services provided by the physical layer of 5G-NR to upper layers.

2 References

The following documents contain provisions which, through reference in this text, constitute provisions of the present document.

- [1] 3GPP TR 21.905: "Vocabulary for 3GPP Specifications"
- [2] 3GPP TS 38.201: "NR; Physical Layer – General Description"
- [3] 3GPP TS 38.211: "NR; Physical channels and modulation"
- [4] 3GPP TS 38.212: "NR; Multiplexing and channel coding"
- [5] 3GPP TS 38.213: "NR; Physical layer procedures for control"
- [6] 3GPP TS 38.214: "NR; Physical layer procedures for data"
- [7] 3GPP TS 38.215: "NR; Physical layer measurements"
- [8] 3GPP TS 38.306: "NR; User Equipment (UE) radio access capabilities"

3 Definitions of terms, symbols and abbreviations

3.1 Terms

For the purposes of the present document, the terms and definitions given in TR 21.905 [1] and the following apply. A term defined in the present document takes precedence over the definition of the same term, if any, in TR 21.905 [1].

3.2 Symbols

For the purposes of the present document, the following symbols apply:

3.3 Abbreviations

For the purposes of the present document, the abbreviations given in TR 21.905 [1] and the following apply. An abbreviation defined in the present document takes precedence over the definition of the same abbreviation, if any, in TR 21.905 [1].

For the purposes of the present document, the following abbreviations apply:

ARQ	Automatic Repeat Request
BCH	Broadcast Channel
CA	Carrier Aggregation
CRC	Cyclic Redundancy Check
DC	Dual Connectivity
DL	Downlink
FEC	Forward Error Correction
GF	Grant-Free
MAC	Medium Access Control

MIMO	Multiple Input Multiple Output
PBCH	Physical Broadcast Channel
PCH	Paging Channel
PDCCH	Physical Downlink Control Channel
PDSCH	Physical Downlink Shared Channel
PRACH	Physical Random Access Channel
PUCCH	Physical Uplink Control Channel
PUSCH	Physical Uplink Shared Channel
RACH	Random Access Channel
RF	Radio Frequency
RNTI	Radio Network Temporary Identifier
SCH	Shared Channel
SI	System Information
SPS	Semi-Persistent Scheduling
SRS	Sounding Reference Signal
TPC	Transmit Power Control
UL	Uplink

4 Services and functions of the physical layer

4.1 General

The physical layer offers data transport services to higher layers.

The access to these services is through the use of transport channels via the MAC sub-layer.

A transport block is defined as the data delivered by MAC layer to the physical layer and vice versa.

4.2 Overview of L1 functions

As mentioned in [2, TS 38.201], the physical layer is expected to perform the following functions to provide the data transport service:

- Error detection on the transport channel and indication to higher layers;
- FEC encoding/decoding of the transport channel;
- Hybrid ARQ soft-combining;
- Rate matching of the coded transport channel to physical channels;
- Mapping of the coded transport channel onto physical channels;
- Power weighting of physical channels;
- Modulation and demodulation of physical channels;
- Frequency and time synchronisation;
- Radio characteristics measurements and indication to higher layers;
- Multiple Input Multiple Output (MIMO) antenna processing;
- RF processing.

L1 functions are modelled for each transport channel in clause 5.

5 Model of physical layer of the UE

The 5G-NR physical-layer model captures those characteristics of the 5G-NR physical-layer that are relevant from the point-of-view of higher layers. More specifically, the physical-layer model captures:

- The structure of higher-layer data being passed down to or up from the physical layer;
- The means by which higher layers can configure the physical layer;
- The different indications (error indications, channel-quality indications, etc.) that are provided by the physical layer to higher layers.

5.1 Uplink model

5.1.1 Uplink shared channel

The physical-layer model for Uplink Shared Channel transmission is described based on the corresponding PUSCH physical-layer-processing chain, see Figure 5.1.1-1. Processing steps that are relevant for the physical-layer model, e.g. in the sense that they are configurable by higher layers, are highlighted in blue.

- Higher-layer data passed to/from the physical layer
- CRC and transport-block-error indication
- FEC and rate matching
- Data modulation
- Mapping to physical resource
- Multi-antenna processing
- Support of L1 control and Hybrid-ARQ-related signalling

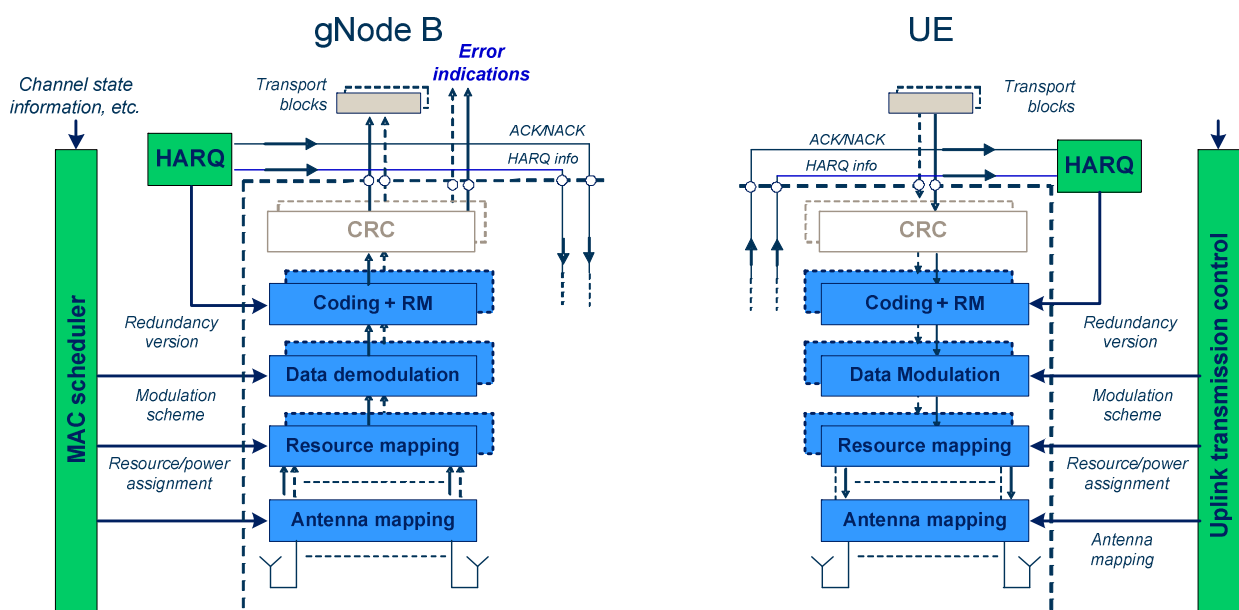

Figure 5.1.1-1: Physical-layer model for UL-SCH transmission

5.1.2 Random access channel

The physical-layer model for RACH transmission is characterized by a PRACH preamble format that consists of a cyclic prefix, a preamble, and a guard time during which nothing is transmitted.

5.2 Downlink model

5.2.1 Downlink shared channel

The physical-layer model for Downlink Shared Channel transmission is described based on the corresponding PDSCH physical-layer-processing chain, see Figure 5.2.1-1. Processing steps that are relevant for the physical-layer model, e.g. in the sense that they are configurable by higher layers, are highlighted in blue.

- Higher-layer data passed to/from the physical layer;
- CRC and transport-block-error indication;
- FEC and rate matching;
- Data modulation;
- Mapping to physical resource;
- Multi-antenna processing;
- Support of L1 control and Hybrid-ARQ-related signalling.

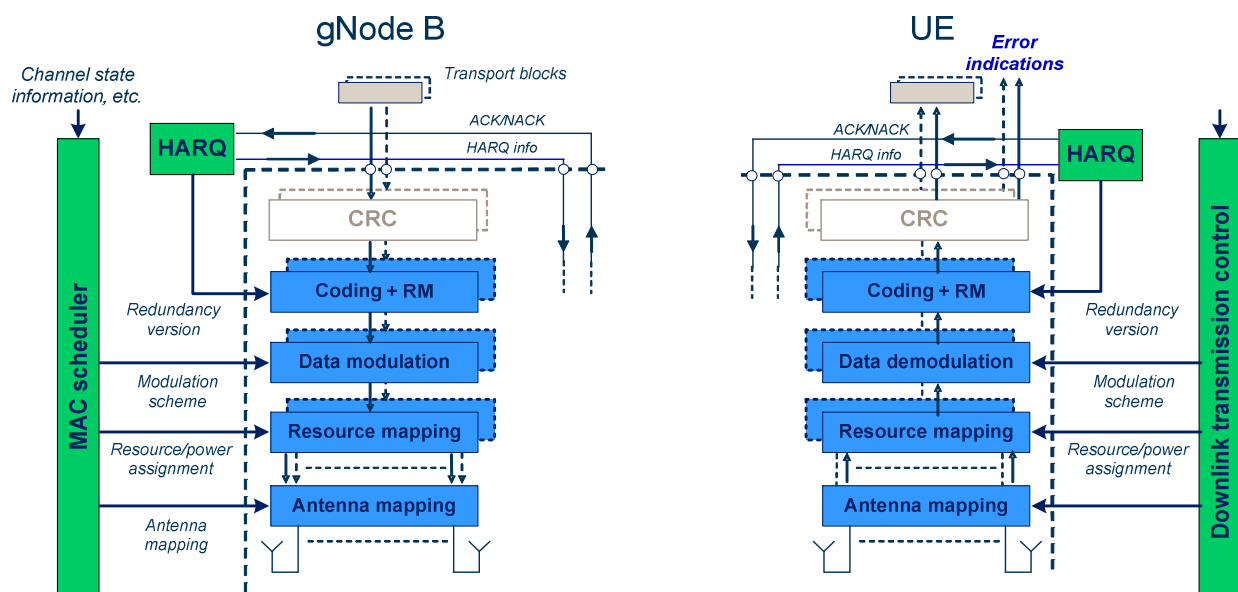

Figure 5.2.1-1: Physical-layer model for DL-SCH transmission

5.2.2 Broadcast channel

The physical-layer model for BCH transmission is characterized by a fixed pre-defined transport format. There is one transport block for the BCH every 80ms. The BCH physical-layer model is described based on the corresponding PBCH physical-layer-processing chain, see Figure 5.2.2-1:

- Higher-layer data passed to/from the physical layer;
- CRC and transport-block-error indication;
- FEC and rate matching;
- Data modulation;
- Mapping to physical resource;
- Multi-antenna processing.

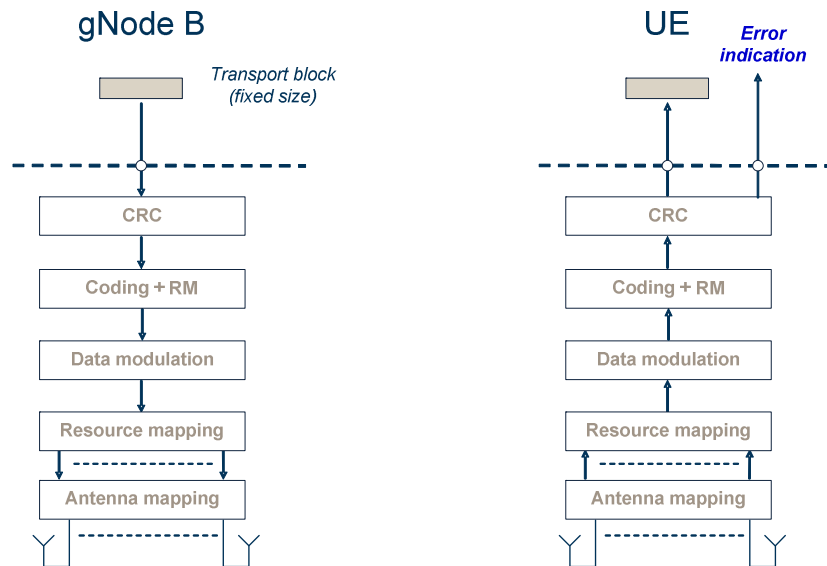

Figure 5.2.2-1: Physical-layer model for BCH transmission

5.2.3 Paging channel

The physical-layer model for PCH transmission is described based on the corresponding physical-layer-processing chain, see Figure 5.2.3-1. The PCH is carried on PDSCH. Processing steps that are relevant for the physical-layer model, e.g. in the sense that they are configurable by higher layers, are highlighted in blue.

- Higher-layer data passed to/from the physical layer;
- CRC and transport-block-error indication;
- FEC and rate matching;
- Data modulation;
- Mapping to physical resource;
- Multi-antenna processing.

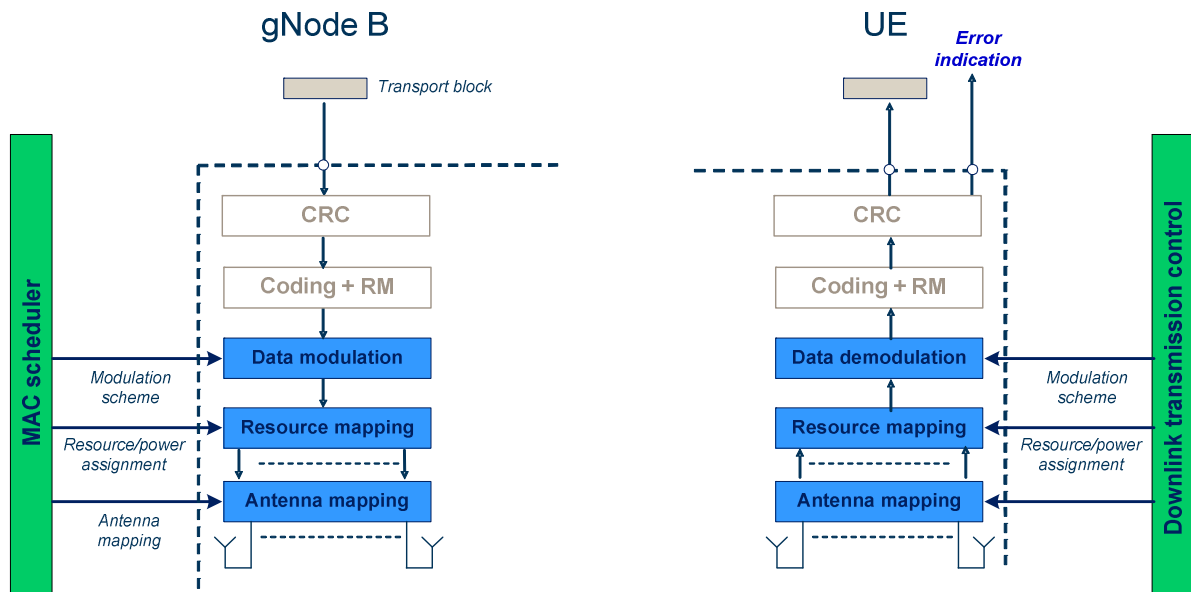

Figure 5.2.3-1: Physical-layer model for PCH transmission

5.3 Sidelink model

5.3.1 Sidelink shared channel

The physical-layer model for Sidelink Shared Channel transmission is described based on the corresponding SL-SCH physical-layer-processing chain, see Figure 5.3.1-1. Processing steps that are relevant for the physical-layer model, e.g. in the sense that they are configurable by higher layers, are highlighted in blue.

- Higher-layer data passed to/from the physical layer;
- CRC and transport-block-error indication;
- FEC and rate matching;
- Data modulation;
- Mapping to physical resource;
- Multi-antenna processing;
- Support of L1 control and Hybrid-ARQ-related signalling.

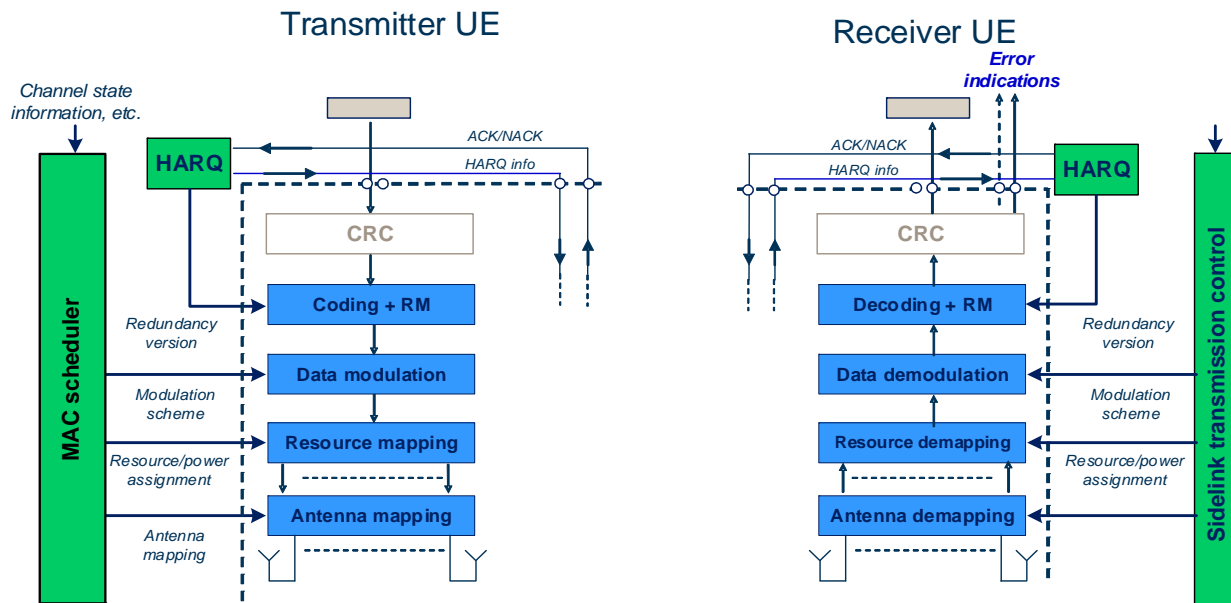

Figure 5.3.1-1: Physical-layer model for SL-SCH transmission

5.3.2 Broadcast channel

The physical-layer model for Sidelink Broadcast Channel transmission is characterized by a fixed pre-defined transport format. There is one transport block for every slot in which the UE transmits SL-BCH, if the UE is configured to transmit on SL-BCH. The SL-BCH physical-layer model is described based on the corresponding SL-BCH physical-layer-processing chain, see Figure 5.3.2-1:

- Higher-layer data passed to/from the physical layer;
- CRC and transport-block-error indication;
- FEC and rate matching;
- Data modulation;
- Mapping to physical resource;
- Multi-antenna processing.

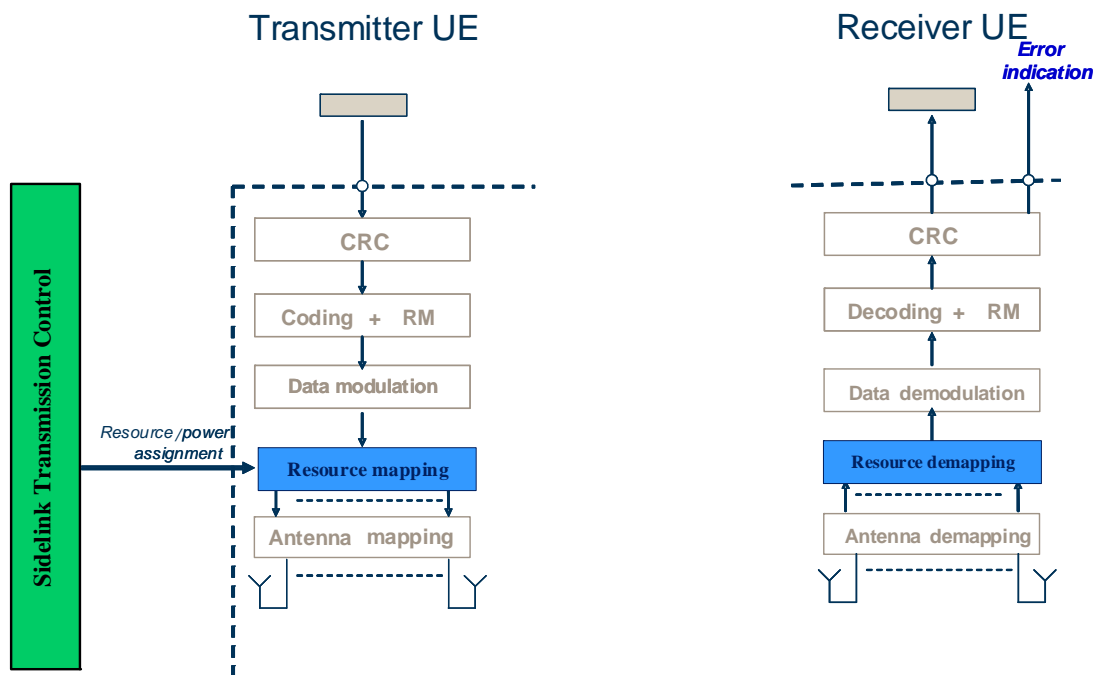

Figure 5.3.2-1: Physical-layer model for SL-BCH transmission

6 Simultaneous transmission and reception of physical channels and physical signals

This clause describes the requirements from the UE to send and receive multiple physical channels and physical signals simultaneously depending on the capabilities and service requirements. The following notation is used between both the uplink and downlink clauses below.

- p is the number of uplink carriers configured for the UE on which physical channels can be transmitted
- p' is the number of uplink carriers configured for the UE on which SRS can be transmitted
- q is the number of downlink carriers configured for the UE
- j is the number of cell groups configured for the UE.
- k is the number of PUCCH groups configured for the UE.

6.1 Uplink

The tables 6.1-1 and 6.1-2 describe the possible combinations of physical channels and SRS that can be sent in simultaneously in the uplink by one UE. Table 6.1-1 introduces notation for a "Transmission Type" which represents a physical channel or sounding reference signal, and any associated transport channel. Table 6.1-2 describes the combinations of these "Transmission Types" which are supported by the UE depending on capabilities [8, TS 38.306], and enumerates how many of each can be transmitted simultaneously.

Table 6.1-1: Uplink "Transmission Types"

"Transmission Type"	Physical Channel or SRS	Associated Transport Channel	Comment
A	PRACH	RACH	Note 1, Note 3
B	PUCCH	N/A	
C	PUSCH	UL-SCH	Note 2, Note 3
D	SRS	N/A	
Note 1: RACH corresponds to contention based. Note 2: UCI on PUSCH without UL-SCH is possible. Note 3: For SCell, MsgA PRACH and MsgA PUSCH is not supported.			

Table 6.1-2: Uplink "Transmission Type" combinations

Supported Combinations	Comment
$j \times A$	Note 1
$k \times B$	Note 2
$(\sum_{i=1}^p m_i) \times C$	Note 3, Note 4, Note 10
$p' \times D$	Note 3, Note 5
$j \times A + \tilde{k} \times B$	Note 6
$j \times A + (\sum_{i=1}^{\tilde{p}} \tilde{m}_i) \times C$	Note 6, Note 10
$j \times A + \tilde{p}' \times D$	Note 6
$\hat{k} \times B + (\sum_{i=1}^{\hat{p}} \hat{m}_i) \times C$	Note 8, Note 10
$B + (\sum_{i=1}^{\tilde{p}'} \tilde{m}_i) \times C$	Note 9, Note 10
$\tilde{k} \times B + \tilde{p}' \times D$	Note 7
$(\sum_{i=1}^{\tilde{p}} \tilde{m}_i) \times C + \tilde{p}' \times D$	Note 7, Note 10
Note 1: The number of cell groups j in the supported combination is subject to UE capability. Note 2: The number of PUCCH groups k in the supported combination is subject to UE capability. Note 3: The number of carriers p , and p' in the supported combinations are subject to UE capability. Note 4: In the case there is one SUL carrier, then $p-1$ would be supported. Note 5: UE may be configured with p' but may also have capability to simultaneously sound less than this number. Note 6: Simultaneous PRACH with PUCCH (or PUSCH or SRS) is supported only in the case of inter-band CA, with $j \leq j$, $\tilde{k} \leq k$, $\tilde{p} \leq p$, and $\tilde{p}' \leq p'$ depending on the configuration, and subject to UE capability for parallel transmission. Note 7: Simultaneous SRS with PUCCH (or PUSCH) is supported only in the case of inter-band CA, with $\tilde{k} \leq k$, $\tilde{p} \leq p$, and $\tilde{p}' \leq p'$ depending on the configuration, and subject to UE capability for parallel transmission. Note 8: Simultaneous PUCCH and PUSCH(s) for the case that multiple PUCCH groups are configured and the respective PUCCH and PUSCH(s) are transmitted in the different PUCCH groups, with $\hat{k} < k$ and $\hat{p} \leq p$. k and p are subject to UE capability for supported number of PUCCH groups and UL carriers, respectively. \hat{k} and \hat{p} depend on configuration. Note 9: Simultaneous PUCCH and PUSCH(s) within the same PUCCH group in the case of inter-band CA, \tilde{p}' depending on the configuration, and subject to UE capability for parallel transmission of PUCCH and PUSCH within the same PUCCH group. Note 10: Simultaneous transmission of up to 2 PUSCHs within the same active UL BWP, with $p, \tilde{p}, \hat{p}, \tilde{p}'$ depending on the configuration, $m_i, \tilde{m}_i, \hat{m}_i, \tilde{m}_i'$ equal to 1 or 2, subject to UE capability for parallel transmission of PUSCH and PUSCH within the same active UL BWP.	

6.2 Downlink

The tables 6.2-1, 6.2-2 describe the possible combinations of physical channels that can be received simultaneously in the downlink by one UE. Table 6.2-1 introduces notation for a "Reception Type" which represents a physical channel and any associated transport channel. Table 6.2-2 describes the combinations of these "Reception Types" which are supported by the UE depending on capabilities [8, TS 38.306], and enumerates how many of each can be received simultaneously. The UE shall be able to receive all TBs according to the indication on PDCCH. Any subset of the combinations specified in table 6.2-2 is also supported.

Table 6.2-1: Downlink "Reception Types"

"Reception Type"	Physical Channel(s)	Monitored RNTI	Associated Transport Channel	Comment
A	PBCH	N/A	BCH	
B	PDCCH+PDSCH	SI-RNTI	DL-SCH	Note 1
C0	PDCCH	P-RNTI	N/A	Note 1, Note 2
C1	PDCCH+PDSCH	P-RNTI	PCH	Note 1
D0	PDCCH+PDSCH	RA-RNTI or Temporary C-RNTI or MsgB-RNTI	DL-SCH	Note 3
D1	PDCCH+PDSCH	C-RNTI, CS-RNTI, MCS-C-RNTI	DL-SCH	
D2	PDCCH	C-RNTI, CS-RNTI, MCS-C-RNTI	DL-SCH	
D3	PDCCH+PDSCH	G-RNTI, G-CS-RNTI	DL-SCH	Note 6
D4	PDCCH	G-CS-RNTI	N/A	Note 7
D5	PDCCH+PDSCH	MCCH-RNTI	DL-SCH	Note 8
D6	PDCCH+PDSCH	G-RNTI	DL-SCH	Note 9
D7	PDCCH+PDSCH	C-RNTI	DL-SCH	Note 10
D8	PDCCH+PDSCH	multicast-MCCH-RNTI	DL-SCH	Note 11
E	PDCCH	C-RNTI	N/A	Note 4
F0	PDCCH	Temporary C-RNTI	UL-SCH	Note 3
F1	PDCCH	C-RNTI, CS-RNTI, MCS-C-RNTI	UL-SCH	
F2	PDCCH	C-RNTI, CS-RNTI	UL-SCH	Note 10
G	PDCCH	SFI-RNTI	N/A	
H	PDCCH	INT-RNTI	N/A	
J0	PDCCH	TPC-PUSCH-RNTI	N/A	
J1	PDCCH	TPC-PUCCH-RNTI	N/A	
J2	PDCCH	TPC-SRS-RNTI	N/A	
K	PDCCH	SP-CSI-RNTI	N/A	
L0	PDCCH	SL-RNTI	SL-SCH	
L1	PDCCH	SL-CS-RNTI	SL-SCH	
M	PDCCH	SL Semi-Persistent Scheduling V-RNTI	SL-SCH	Note 5
N	PDCCH	PS-RNTI	N/A	
O	PDCCH	AI-RNTI	N/A	
P	PDCCH	CI-RNTI	N/A	
Q	PDCCH	PEI-RNTI	N/A	Note 1

Note 1: These are received from PCell only.

Note 2: In some cases UE is only required to monitor the short message within the DCI for P-RNTI.

Note 3: These are received from PCell or PSCell.

Note 4: This corresponds to PDCCH-ordered PRACH.

Note 5: This corresponds to PDCCH scheduling LTE PC5.

Note 6: This is for multicast in RRC connected state.

Note 7: This corresponds to DL Semi-Persistent Scheduling release for multicast in RRC connected state.

Note 8: This is for broadcast MCCH.

Note 9: This is for broadcast MTCH. UE is not required to decode more than one PDSCH for MTCH simultaneously.

Note 10: This is for small data transmission in RRC inactive state.

Note 11: This is for multicast MCCH in RRC inactive state.

Table 6.2-2: Downlink "Reception Type" combinations

Supported Combinations			Comment
PCell	PSCell	SCell	
1. RRC_IDLE			
1.1 All UEs			
A + (B and/or (C1 or Q) and/or D0) + F0			Note 1
1.2 UEs supporting MBS broadcast reception			
A+D5			
2. RRC_INACTIVE			
2.1 All UEs			
A + (B and/or (C0 or C1 or Q) and/or (D0 or D7)) + (F0 or F2)			Note 1
2.2 UEs supporting MBS broadcast reception			
A+D5			
2.3 UE supporting MBS multicast reception			
A+D8			
3. RRC_CONNECTED			
$(A + ((C0 + (B \text{ and/or } (D0 \text{ or } (m1 \cdot D1 + m2 \cdot D2 + ((m3 \cdot D3 + m4 \cdot D4) \text{ or } m5 \cdot (D5 \text{ or } D6)))))) + E + F0 + n \cdot F1 + G + H + J0 + J1 + J2 + K + O + L0 + L1 + M + N + P) \text{ or } D5))$	$(A + (D0 \text{ or } (m1 \cdot D1 + m2 \cdot D2)) + E + F0 + n \cdot F1 + G + H + J0 + J1 + J2 + K + O + N + P)$	$m1 \cdot D1 + m2 \cdot D2 + ((m3 \cdot D3 + m4 \cdot D4) \text{ or } m5 \cdot (D5 \text{ or } D6)) + E + n \cdot F1 + G + H + J0 + J1 + J2 + K + O + L0 + L1 + M + P$	Note 2, Note 3, Note 4, Note 5, Note 6, Note 7, Note 8, Note 9, Note 10, Note 11, Note 12, Note 13, Note 14
<p>Note 1: UE is not required to decode more than two PDSCH simultaneously, and decoding prioritization when more than two are received is up to UE implementation.</p> <p>Note 2: For PCell, UE is not required to decode SI-RNTI PDSCH simultaneously with C-RNTI PDSCH, unless in FR1.</p> <p>Note 3: Supported combinations are subject to UE capabilities for dual connectivity, carrier aggregation, receiving of group TPC commands, pre-emption indication and dynamic SFI monitoring.</p> <p>Note 4: The values of $m2 \geq 0$ and $n \geq 0$ in the supported combinations are subject to the UE capability.</p> <p>Note 5: Support of monitoring PDCCH with SL-RNTI, SL-CS-RNTI, SL Semi-Persistent Scheduling V-RNTI are subject to UE capability.</p> <p>Note 6: The values of $m1 \geq 1$ in the supported combinations are subject to the UE capability.</p> <p>Note 7: In Active time, a UE is not expected to monitor the DCI format for the PDCCH scrambled by PS-RNTI.</p> <p>Note 8: The PDCCH scrambled by PS-RNTI can only be configured on the PCell and PSCell.</p> <p>Note 9: For a UE supporting MBS multicast reception, the values of $1 \geq m3 \geq 0$ and $m4 \geq 0$ are subject to UE capability and applicable to RRC connected UEs. If $m3 = 1$, then $m1 \leq 1$.</p> <p>Note 10: For a UE supporting MBS multicast or broadcast reception, the UE is not expected to be configured simultaneously with more than one component carrier for multicast or broadcast reception.</p> <p>Note 11: For a UE supporting MBS broadcast reception, the values of $1 \geq m5 \geq 0$ are subject to UE capability and applicable to RRC connected UEs. If $m5 = 1$, then $m1 \leq 1$.</p> <p>Note 12: For a UE supporting MBS broadcast reception in RRC_CONNECTED state, it is required to support reception of FDMed MCCH PDSCH and PBCH in Pcell.</p> <p>Note 13: For a UE supporting MBS multicast or broadcast reception in RRC_CONNECTED state, it is not required to support reception of FDMed MCCH PDSCH/broadcast MTCH PDSCH/multicast MTCH PDSCH and SIB PDSCH in PCell.</p> <p>Note 14: For a UE supporting MBS multicast or broadcast reception in RRC_CONNECTED state, it is not required to support reception of FDMed broadcast MTCH PDSCH/multicast MTCH PDSCH and PBCH in PCell.</p>			

6.3 Sidelink

The tables 6.3-1 and 6.3-2 describe the possible combinations of physical channels that can be sent simultaneously in the sidelink by a UE. Table 6.3-1 introduces notation for a sidelink "Transmission Type" which represents a physical channel, and any associated transport channel. Table 6.3-2 describes the combinations of these "Transmission Types"

which are supported by the UE depending on capabilities [8, TS 38.306], and enumerates how many of each can be transmitted simultaneously.

Table 6.3-1: Sidelink "Transmission Types"

"Transmission Type"	Physical Channel	Associated Transport Channel	Comment
A	PSBCH	SL-BCH	
B	PSSCH	SL-SCH	
C	PSCCH	SL-SCH	
D	PSFCH	N/A	
E	SL PRS	N/A	

Table 6.3-2: Sidelink "Transmission Type" combinations

Supported Combinations	Comment
A	Note 2
B	Note 2
C	Note 2
E	Note 4
E	Note 5
$N \times D$	Note 2
B+C	Note 2
Note 1: Depending on the UE capability, the UE may be able to perform simultaneous Uplink and Sidelink transmissions. If the simultaneous transmission of Sidelink and Uplink is beyond the UE capability, the one not prioritized can be dropped according to [TS 38.321]. Note 2: Depending on the UE capability, the UE may be able to perform simultaneous sidelink communication transmissions of the same sidelink "Transmission Type" combinations across multiple SL carriers. Note 3: Simultaneous transmissions over multiple SL carriers with one or more UL carriers is left up to UE implementation. Note 4: Depending on the UE capability, the UE may be able to perform simultaneous SL PRS transmission and PSSCH transmission(s) for a shared SL PRS resource pool across multiple SL carriers. Note 5: Depending on the UE capability, applicable for a dedicated SL PRS resource pool across multiple SL carriers.	

The tables 6.3-3 and 6.3-4 describe the possible combinations of physical channels that can be received simultaneously in the sidelink by a UE. Table 6.3-3 introduces notation for a sidelink "Reception Type" which represents a physical channel, and any associated transport channel. Table 6.3-4 describes the combinations of these "Reception Types" which are supported by the UE depending on capabilities [8, TS 38.306], and enumerates how many of each can be received simultaneously.

Table 6.3-3: Sidelink "Reception Types"

"Reception Type"	Physical Channel	Associated Transport Channel	Comment
A	PSBCH	SL-BCH	
B	PSSCH	SL-SCH	
C	PSCCH	SL-SCH	
D	PSFCH	N/A	
E	SL PRS	N/A	

Table 6.3-4: Sidelink "Reception Type" combinations

Supported Combinations	Comment
A	
B	Note 1, Note 2
C	Note 1, Note 2
E	Note 3, Note 5
$M_1 \times E$	Note 4
$M \times D$	Note 2
B+C	Note 1, Note 2
<p>Note 1: Corresponds to simultaneous reception within one sub-channel</p> <p>Note 2: Depending on the UE capability, the UE may be able to perform simultaneous sidelink communication receptions of the same sidelink "Reception Type" combinations across multiple SL carriers.</p> <p>Note 3: Applicable for a shared SL PRS resource pool. Corresponds to simultaneous reception within one sub-channel.</p> <p>Note 4: Applicable for a dedicated SL PRS resource pool with $M_1 \geq 1$. Corresponds to simultaneous reception within one dedicated SL PRS resource pool.</p> <p>Note 5: For a shared SL PRS resource pool, depending on the UE capability, the reception(s) of SL-PRS in a single SL carrier can be simultaneously received with PSSCH in other one or more SL carrier(s).</p>	

7 Measurements provided by the physical layer

7.1 UE measurements

The list and detailed definition of UE measurements is provided in [7, TS 38.215].

Annex A (informative): Change history

Change history							
Date	Meeting	TDoc	CR	Rev	Cat	Subject/Comment	New version
2017-05	RAN1#89	R1-1712013				Draft skeleton	0.0.0
2017-07	AH_1706	R1-1712013				Update for agreements from meetings up to RAN1 NR AH2	0.0.1
2017-08	RAN1#90	R1-1713371				Update for agreements from meetings up to RAN1 NR AH2	0.0.2
2017-08	RAN1#90	R1-1714655				Update with change marks removed for RAN1 #90 endorsement	0.1.0
2017-09	RAN1#90	R1-1715320				Updated with minor editorial changes for review after RAN1 #90	0.1.1
2017-09	RAN#77	RP-172006				For information to plenary	1.0.0
2017-10	RAN1#90b	R1-1719229				Updated for agreements from meetings up to RAN1 #90b	1.0.1
2017-11	RAN1#91	R1-1721047				Updated after email discussion	1.1.0
2017-12	RAN1#91	R1-1721340				Updated to reflect agreements from RAN1 #91	1.2.0
2017-12	RAN#78	RP-172630				Endorsed version for approval by plenary	2.0.0
2017-12	RAN#78					Approved by plenary – Rel-15 spec under change control	15.0.0
2018-03	RAN#79	RP-180200	0001	-	F	CR capturing the Jan18 ad-hoc and RAN1#92 meeting agreements	15.1.0
2018-06	RAN#80	RP-181172	0002	1	F	CR to 38.202 capturing the RAN1#92bis and RAN1#93 meeting agreements	15.2.0
2018-06	RAN#80	RP-181257	0003	-	B	CR to 38.202 capturing the RAN1#92bis and RAN1#93 meeting agreements related to URLLC	15.2.0
2018-09	RAN#81	RP-181789	0004	-	B	CR to 38.202 capturing RAN1#94 meeting agreements	15.3.0
2018-12	RAN#82	RP-182523	0005	-	F	CR to 38.202 capturing RAN1#95 meeting agreements	15.4.0
2019-06	RAN#84	RP-191277	0006	-	F	Correction to simultaneous reception of DL Channels	15.5.0
2019-06	RAN#84	RP-191277	0007	-	F	CR on inclusion of TC-RNTI for monitored RNTI for UL-SCH and inclusion of monitoring PDCCH ordering PRACH on SCell	15.5.0
2019-12	RAN#86	RP-192623	0008	1	F	CR on simultaneous transmission of UL channels	15.6.0
2019-12	RAN#86	RP-192635	0009	-	B	Introduction of two-step RACH	16.0.0
2019-12	RAN#86	RP-192637	0010	-	B	Introduction of integrated access and backhaul for NR	16.0.0
2019-12	RAN#86	RP-192638	0011	-	B	Introduction of V2X	16.0.0
2019-12	RAN#86	RP-192639	0012	-	B	Introduction of Physical Layer Enhancements for URLLC	16.0.0
2019-12	RAN#86	RP-192641	0013	-	B	Introduction of MIMO enhancements	16.0.0
2019-12	RAN#86	RP-192642	0014	-	B	Introduction of UE Power Savings	16.0.0
2020-06	RAN#88-e	RP-200692	0015	-	F	Corrections to MIMO enhancements	16.1.0
2020-09	RAN#89-e	RP-201810	0017	-	F	DL Channel Combination associated with DCI format 2_6 monitoring	16.2.0
2020-09	RAN#89-e	RP-201807	0018	-	F	Corrections on 5G V2X sidelink features	16.2.0
2021-12	RAN#94-e	RP-212960	0019	-	F	Alignment CR for TS 38.202	16.3.0
2021-12	RAN#94-e	RP-212968	0020	-	B	Introduction of IIoT/URLLC enhancements in NR	17.0.0
2021-12	RAN#94-e	RP-212979	0021	-	B	Introduction of multicast and broadcast services	17.0.0
2022-03	RAN#95-e	RP-220263	0022	-	F	Corrections to NR support of multicast and broadcast services	17.1.0
2022-03	RAN#95-e	RP-220256	0023	-	F	Corrections on NR UE Power Saving Enhancements	17.1.0
2022-06	RAN#96	RP-221612	0024	-	F	Corrections to NR support of multicast and broadcast services	17.2.0
2022-12	RAN#98-e	RP-222864	0025	-	F	CR on the MBS reception type combinations to TS 38.202	17.3.0
2023-09	RAN#101	RP-232450	0026	-	F	Correction on simultaneous reception of SDT and other channels in TS 38.202	17.4.0
2023-09	RAN#101	RP-232458	0027	-	B	Release 18 TS38.202 Editor CR for MIMO	18.0.0
2023-09	RAN#101	RP-232469	0028	-	B	Release 18 TS38.202 Editor CR for NR sidelink evolution	18.0.0
2023-12	RAN#102	RP-233723	0031	1	A	Correction on NR Sidelink	18.1.0
2023-12	RAN#102	RP-233733	0032	-	B	Release 18 TS38.202 Editor CR for multicast in RRC_INACTIVE state	18.1.0
2023-12	RAN#102	RP-233719	0033	-	F	Release 18 TS38.202 Editor CR for SL-PRS transmission and Reception	18.1.0

2024-03	RAN#103	RP-240528	0034	-	F	Release 18 TS38.202 Editor CR for simultaneous SL-PRS transmission and Reception	18.2.0
2024-06	RAN#104	RP-241061	0035	-	F	Correction to 38.202 on support of combination of SL CA and SL positioning	18.3.0

History

Document history		
V18.2.0	May 2024	Publication
V18.3.0	August 2024	Publication