

ETSI TS 138 351 V19.1.0 (2026-02)



TECHNICAL SPECIFICATION

**5G;  
NR;  
Sidelink Relay Adaptation Protocol (SRAP) Specification  
(3GPP TS 38.351 version 19.1.0 Release 19)**



---

**Reference**

RTS/TSGR-0238351vj10

---

**Keywords**

5G

**ETSI**

650 Route des Lucioles  
F-06921 Sophia Antipolis Cedex - FRANCE

---

Tel.: +33 4 92 94 42 00 Fax: +33 4 93 65 47 16

Siret N° 348 623 562 00017 - APE 7112B  
Association à but non lucratif enregistrée à la  
Sous-Préfecture de Grasse (06) N° w061004871

---

**Important notice**

The present document can be downloaded from the  
[ETSI Search & Browse Standards](#) application.

The present document may be made available in electronic versions and/or in print. The content of any electronic and/or print versions of the present document shall not be modified without the prior written authorization of ETSI. In case of any existing or perceived difference in contents between such versions and/or in print, the prevailing version of an ETSI deliverable is the one made publicly available in PDF format on [ETSI deliver](#) repository.

Users should be aware that the present document may be revised or have its status changed, this information is available in the [Milestones listing](#).

If you find errors in the present document, please send your comments to the relevant service listed under [Committee Support Staff](#).

If you find a security vulnerability in the present document, please report it through our [Coordinated Vulnerability Disclosure \(CVD\)](#) program.

---

**Notice of disclaimer & limitation of liability**

The information provided in the present deliverable is directed solely to professionals who have the appropriate degree of experience to understand and interpret its content in accordance with generally accepted engineering or other professional standard and applicable regulations.

No recommendation as to products and services or vendors is made or should be implied.

No representation or warranty is made that this deliverable is technically accurate or sufficient or conforms to any law and/or governmental rule and/or regulation and further, no representation or warranty is made of merchantability or fitness for any particular purpose or against infringement of intellectual property rights.

In no event shall ETSI be held liable for loss of profits or any other incidental or consequential damages.

Any software contained in this deliverable is provided "AS IS" with no warranties, express or implied, including but not limited to, the warranties of merchantability, fitness for a particular purpose and non-infringement of intellectual property rights and ETSI shall not be held liable in any event for any damages whatsoever (including, without limitation, damages for loss of profits, business interruption, loss of information, or any other pecuniary loss) arising out of or related to the use of or inability to use the software.

---

**Copyright Notification**

No part may be reproduced or utilized in any form or by any means, electronic or mechanical, including photocopying and microfilm except as authorized by written permission of ETSI.

The content of the PDF version shall not be modified without the written authorization of ETSI.

The copyright and the foregoing restriction extend to reproduction in all media.

© ETSI 2026.  
All rights reserved.

---

# Intellectual Property Rights

## Essential patents

IPRs essential or potentially essential to normative deliverables may have been declared to ETSI. The declarations pertaining to these essential IPRs, if any, are publicly available for **ETSI members and non-members**, and can be found in ETSI SR 000 314: "*Intellectual Property Rights (IPRs); Essential, or potentially Essential, IPRs notified to ETSI in respect of ETSI standards*", which is available from the ETSI Secretariat. Latest updates are available on the [ETSI IPR online database](#).

Pursuant to the ETSI Directives including the ETSI IPR Policy, no investigation regarding the essentiality of IPRs, including IPR searches, has been carried out by ETSI. No guarantee can be given as to the existence of other IPRs not referenced in ETSI SR 000 314 (or the updates on the ETSI Web server) which are, or may be, or may become, essential to the present document.

## Trademarks

The present document may include trademarks and/or tradenames which are asserted and/or registered by their owners. ETSI claims no ownership of these except for any which are indicated as being the property of ETSI, and conveys no right to use or reproduce any trademark and/or tradename. Mention of those trademarks in the present document does not constitute an endorsement by ETSI of products, services or organizations associated with those trademarks.

**DECT™**, **PLUGTESTS™**, **UMTS™** and the ETSI logo are trademarks of ETSI registered for the benefit of its Members. **3GPP™**, **LTE™** and **5G™** logo are trademarks of ETSI registered for the benefit of its Members and of the 3GPP Organizational Partners. **oneM2M™** logo is a trademark of ETSI registered for the benefit of its Members and of the oneM2M Partners. **GSM®** and the GSM logo are trademarks registered and owned by the GSM Association.

---

# Legal Notice

This Technical Specification (TS) has been produced by ETSI 3rd Generation Partnership Project (3GPP).

The present document may refer to technical specifications or reports using their 3GPP identities. These shall be interpreted as being references to the corresponding ETSI deliverables.

The cross reference between 3GPP and ETSI identities can be found at [3GPP to ETSI numbering cross-referencing](#).

---

# Modal verbs terminology

In the present document "**shall**", "**shall not**", "**should**", "**should not**", "**may**", "**need not**", "**will**", "**will not**", "**can**" and "**cannot**" are to be interpreted as described in clause 3.2 of the [ETSI Drafting Rules](#) (Verbal forms for the expression of provisions).

"**must**" and "**must not**" are **NOT** allowed in ETSI deliverables except when used in direct citation.

# Contents

Intellectual Property Rights .....	2
Legal Notice .....	2
Modal verbs terminology.....	2
Foreword.....	5
1 Scope .....	7
2 References .....	7
3 Definitions of terms, symbols and abbreviations .....	7
3.1 Terms.....	7
3.2 Abbreviations .....	8
4 General .....	8
4.1 Introduction .....	8
4.2 SRAP architecture .....	8
4.2.1 General.....	8
4.2.2 SRAP entities.....	8
4.3 Services .....	12
4.3.1 Services provided to upper layers .....	12
4.3.2 Services expected from lower layers .....	12
4.4 Functions .....	13
4.5 Configurations .....	13
5 Procedures .....	13
5.1 SRAP entity handling.....	13
5.1.1 SRAP entity establishment .....	13
5.1.2 SRAP entity release .....	13
5.2 DL Data transfer.....	14
5.2.1 Receiving operation of U2N Relay UE.....	14
5.2.1a Receiving operation of Intermediate U2N Relay UE .....	14
5.2.2 Transmitting operation of U2N Relay UE .....	14
5.2.2.0 General .....	14
5.2.2.1 Egress link determination.....	14
5.2.2.2 Egress RLC channel determination.....	15
5.2.3 Receiving operation of U2N Remote UE .....	15
5.3 UL Data transfer.....	16
5.3.1 Transmitting operation of U2N Remote UE .....	16
5.3.1.1 UE ID field and BEARER ID field determination .....	16
5.3.1.2 Egress RLC channel determination.....	16
5.3.2 Receiving operation of U2N Relay UE.....	16
5.3.3 Transmitting operation of U2N Relay UE .....	17
5.3.3.1 UE ID field and BEARER ID field determination .....	17
5.3.3.2 Egress RLC channel determination.....	17
5.3a U2U SL Data transfer.....	18
5.3a.1 Transmitting operation of U2U Remote UE .....	18
5.3a.1.1 General .....	18
5.3a.1.2 Egress link, UE ID fields and BEARER ID field determination.....	18
5.3a.1.3 Egress RLC channel determination.....	18
5.3a.2 Receiving operation of U2U Relay UE.....	18
5.3a.3 Transmitting operation of U2U Relay UE .....	19
5.3a.3.1 General .....	19
5.3a.3.2 Egress link determination.....	19
5.3a.3.3 Egress RLC channel determination.....	19
5.3a.4 Receiving operation of U2U Remote UE .....	19
5.4 Handling of unknown, unforeseen, and erroneous protocol data .....	19
6 Protocol data units, formats, and parameters.....	20

6.1	Protocol data units .....	20
6.1.1	Data PDU.....	20
6.2	Formats .....	20
6.2.1	General.....	20
6.2.2	Data PDU.....	20
6.3	Parameters .....	21
6.3.1	General.....	21
6.3.2	UE ID.....	21
6.3.3	BEARER ID .....	22
6.3.4	Data.....	22
6.3.5	R .....	22
6.3.6	D/C.....	22
<b>Annex A (informative): Change history .....</b>		<b>23</b>
History .....		24

---

# Foreword

This Technical Specification has been produced by the 3rd Generation Partnership Project (3GPP).

The contents of the present document are subject to continuing work within the TSG and may change following formal TSG approval. Should the TSG modify the contents of the present document, it will be re-released by the TSG with an identifying change of release date and an increase in version number as follows:

Version x.y.z

where:

- x the first digit:
  - 1 presented to TSG for information;
  - 2 presented to TSG for approval;
  - 3 or greater indicates TSG approved document under change control.
- y the second digit is incremented for all changes of substance, i.e. technical enhancements, corrections, updates, etc.
- z the third digit is incremented when editorial only changes have been incorporated in the document.

In the present document, modal verbs have the following meanings:

- shall** indicates a mandatory requirement to do something
- shall not** indicates an interdiction (prohibition) to do something

The constructions "shall" and "shall not" are confined to the context of normative provisions, and do not appear in Technical Reports.

The constructions "must" and "must not" are not used as substitutes for "shall" and "shall not". Their use is avoided insofar as possible, and they are not used in a normative context except in a direct citation from an external, referenced, non-3GPP document, or so as to maintain continuity of style when extending or modifying the provisions of such a referenced document.

- should** indicates a recommendation to do something
- should not** indicates a recommendation not to do something
- may** indicates permission to do something
- need not** indicates permission not to do something

The construction "may not" is ambiguous and is not used in normative elements. The unambiguous constructions "might not" or "shall not" are used instead, depending upon the meaning intended.

- can** indicates that something is possible
- cannot** indicates that something is impossible

The constructions "can" and "cannot" are not substitutes for "may" and "need not".

- will** indicates that something is certain or expected to happen as a result of action taken by an agency the behaviour of which is outside the scope of the present document
- will not** indicates that something is certain or expected not to happen as a result of action taken by an agency the behaviour of which is outside the scope of the present document
- might** indicates a likelihood that something will happen as a result of action taken by some agency the behaviour of which is outside the scope of the present document

**might not** indicates a likelihood that something will not happen as a result of action taken by some agency the behaviour of which is outside the scope of the present document

In addition:

**is** (or any other verb in the indicative mood) indicates a statement of fact

**is not** (or any other negative verb in the indicative mood) indicates a statement of fact

The constructions "is" and "is not" do not indicate requirements.

---

# 1 Scope

The present document provides description of the Sidelink Relay Adaptation Protocol (SRAP).

---

## 2 References

The following documents contain provisions which, through reference in this text, constitute provisions of the present document.

- References are either specific (identified by date of publication, edition number, version number, etc.) or non-specific.
- For a specific reference, subsequent revisions do not apply.
- For a non-specific reference, the latest version applies. In the case of a reference to a 3GPP document (including a GSM document), a non-specific reference implicitly refers to the latest version of that document *in the same Release as the present document*.

- [1] 3GPP TR 21.905: "Vocabulary for 3GPP Specifications".
  - [2] 3GPP TS 38.300: "NG Radio Access Network; Overall description".
  - [3] 3GPP TS 38.331: "NR Radio Resource Control (RRC); Protocol Specification".
  - [4] 3GPP TS 38.322: "NR Radio Link Control (RLC) protocol specification".
  - [5] 3GPP TS 38.323: "NR; Packet Data Convergence Protocol (PDCP) specification".
- 

## 3 Definitions of terms, symbols and abbreviations

### 3.1 Terms

For the purposes of the present document, the terms given in TR 21.905 [1] and the following apply. A term defined in the present document takes precedence over the definition of the same term, if any, in TR 21.905 [1].

**Child UE:** a U2N Relay UE's next hop in downstream direction for serving a U2N Remote UE in U2N Relay communication. Child UE can be the U2N Remote UE or a U2N Relay UE.

**Downstream:** direction toward U2N Remote UE in U2N Relay communication.

**Egress RLC channel:** a RLC channel on which a packet is transmitted by a U2N Relay UE, a U2N Remote UE, a U2U Remote UE, a U2U Relay UE or a network node.

**Egress link:** a radio link on which a packet is transmitted by a U2N Relay UE, a U2N Remote UE, a U2U Remote UE, a U2U Relay UE or a network node.

**Ingress RLC channel:** a RLC channel on which a packet is received from a U2N Relay UE, a U2N Remote UE, a U2U Remote UE, a U2U Relay UE or a network node.

**Ingress link:** a radio link on which a packet is received from a U2N Relay UE, a U2N Remote UE, a U2U Remote UE, a U2U Relay UE or a network node.

**Intermediate U2N Relay UE:** a U2N Relay UE having both PC5 connection to a parent UE and PC5 connection to a child UE or a U2N Remote UE for serving the U2N Remote UE in case of multi-hop L2 U2N Relay communication.

**Last U2N Relay UE:** a U2N Relay UE having both Uu connection to the network and PC5 connection to a child UE for serving a U2N Remote UE in case of L2 U2N Relay communication. The child UE is the U2N Remote UE in case of single-hop L2 U2N Relay communication.

**Parent UE:** a U2N Remote UE or U2N Relay UE's next hop U2N Relay UE in upstream direction for serving the U2N Remote UE in U2N Relay communication.

**U2N Relay UE:** a UE that provides functionality to support connectivity to the network for U2N Remote UE(s). Up to three L2 U2N Relay UEs (i.e., one Last U2N Relay and up to two Intermediate U2N Relays including one First U2N Relay) can be configured for serving a L2 U2N Remote UE in multi-hop L2 U2N Relay communication in this release.

**U2N Remote UE:** a UE that communicates with the network via one or more U2N Relay UEs on an indirect path.

**U2U Relay UE:** a UE that provides functionality to support connectivity between two U2U Remote UEs.

**U2U Remote UE:** a UE that communicates with other UE(s) via a U2U Relay UE.

**UE-to-Network Relay communication:** a mode of communication in which a UE communicates with the network through an indirect path involving only one U2N Relay UE for single-hop L2 U2N Relay communication or multiple L2 U2N Relay UEs for multi-hop L2 U2N Relay communication.

**Upstream:** direction toward gNB in U2N Relay communication.

## 3.2 Abbreviations

For the purposes of the present document, the abbreviations given in TR 21.905 [1] and the following apply. An abbreviation defined in the present document takes precedence over the definition of the same abbreviation, if any, in TR 21.905 [1].

SRAP	Sidelink Relay Adaptation Protocol
U2N	UE-to-Network
U2U	UE-to-UE

---

# 4 General

## 4.1 Introduction

The objective is to describe the SRAP architecture and the SRAP entities from a functional point of view.

## 4.2 SRAP architecture

### 4.2.1 General

This clause describes a model of the SRAP, i.e., it does not specify or restrict implementations.

### 4.2.2 SRAP entities

Figure 4.2.2-1 represents one possible structure for the SRAP sublayer. The figure is based on the radio interface protocol architecture defined in TS 38.300 [2].

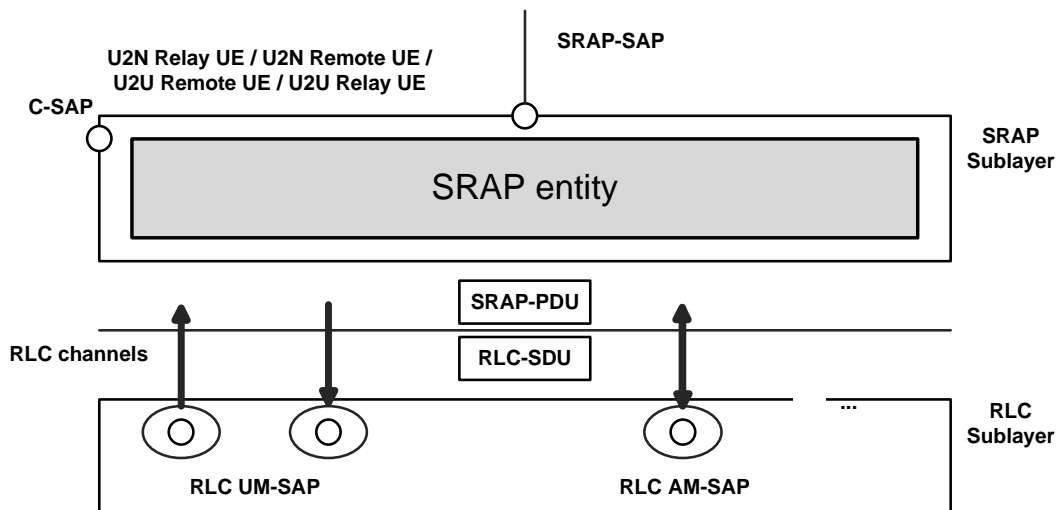

**Figure 4.2.2-1: SRAP structure overview**

On the U2N Relay UE in single-hop U2N Relay and the last Relay UE in multi-hop U2N Relay, the SRAP sublayer contains one SRAP entity at Uu interface and a separate collocated SRAP entity at the PC5 interface. On the U2N Remote UE and intermediate Relay UE, the SRAP sublayer contains only one SRAP entity at the PC5 interface. On the U2U Relay UE and U2U Remote UE, the SRAP sublayer contains only one SRAP entity at the PC5 interface.

Each SRAP entity has a transmitting part and a receiving part. Across the PC5 interface in the U2N case, the transmitting part of the SRAP entity at the U2N Remote UE has a corresponding receiving part of an SRAP entity at the U2N Relay UE, and vice versa. Across the Uu interface, the transmitting part of the SRAP entity at the U2N Relay UE has a corresponding receiving part of an SRAP entity at the gNB, and vice versa.

Across the PC5 interface in the U2U case, the transmitting part of the SRAP entity at the U2U Remote UE has a corresponding receiving part of an SRAP entity at the U2U Relay UE, and vice versa.

Across the PC5 interface in the multi-hop U2N relay case, the transmitting part of the SRAP entity at each UE has a corresponding receiving part of an SRAP entity at the Parent UE, and vice versa.

Figure 4.2.2-2 and Figure 4.2.2-3 represents the functional view of the SRAP entity in U2N Relay case for the SRAP sublayer at PC5 interface and at Uu interface respectively. Figure 4.2.2-4 represents the functional view of the SRAP entity in U2U Relay case for the SRAP sublayer at PC5 interface.

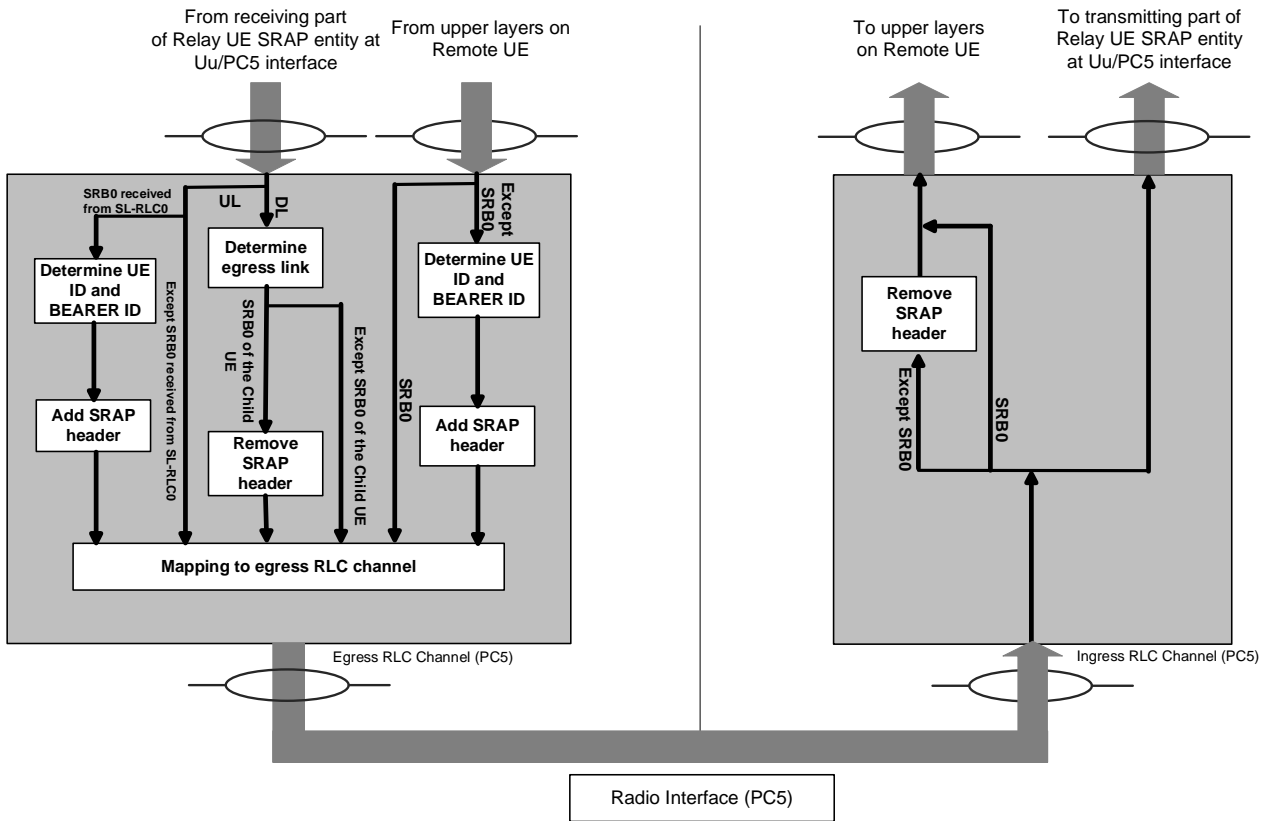
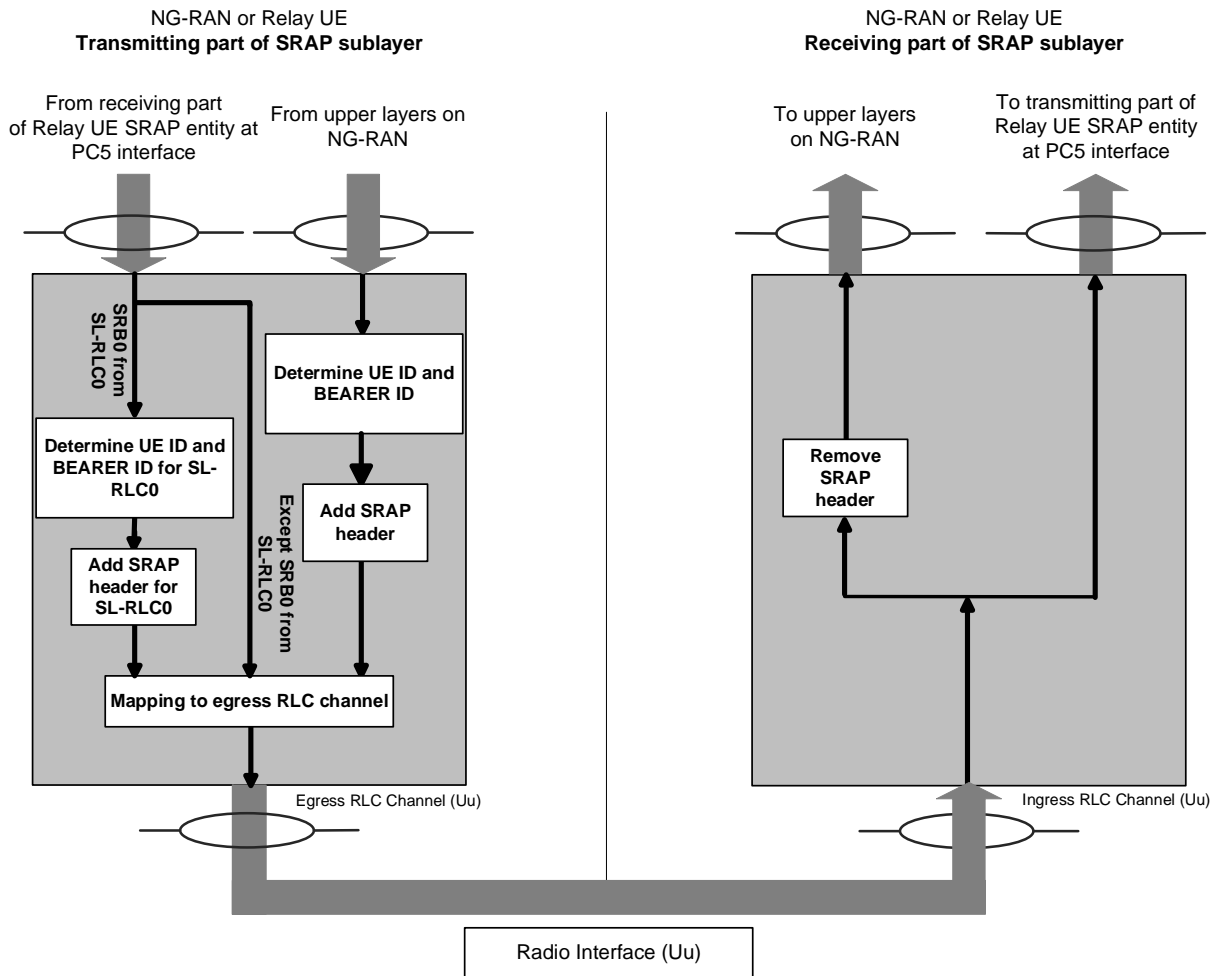

Figure 4.2.2-2: Example of functional view of SRAP sublayer at PC5 interface in U2N Relay case



**Figure 4.2.2-3: Example of functional view of SRAP sublayer at Uu interface**

In the example of Figure 4.2.2-2 and Figure 4.2.2-3, at relay UE:

- For data packet not corresponding to SRB0 of the Child UE, the receiving part on the SRAP entity of Uu or PC5 interface delivers SRAP Data PDUs to the transmitting part on the collocated SRAP entity of PC5 interface for DL data packets, and the receiving part on the SRAP entity of PC5 interface delivers SRAP Data PDUs to the transmitting part on the collocated SRAP entity of Uu or PC5 interface for UL data packets. As an alternative, the receiving part may deliver SRAP SDUs to the transmitting part on the collocated SRAP entity. When passing SRAP SDUs, the receiving part removes the SRAP header and the transmitting part of the relay UE adds the SRAP header with the same SRAP header content as carried on the SRAP Data PDU header prior to removal. Passing SRAP SDUs in this manner is therefore functionally equivalent to passing SRAP Data PDUs, in implementation. The following specification therefore refers to the passing of SRAP data packets.
- For UL data packet corresponding to SRB0 of the Child UE, the receiving part on the SRAP entity of PC5 interface delivers SRAP SDUs to the transmitting part on the collocated SRAP entity of Uu or PC5 interface, and the transmitting part on the SRAP entity of Uu or PC5 interface adds the SRAP header in accordance with clause 5.3.3.
- For DL data packet corresponding to SRB0 of the Child UE, the receiving part on the SRAP entity of Uu or PC5 interface delivers SRAP Data PDUs to the transmitting part on the collocated SRAP entity of PC5 interface, and the transmitting part on the SRAP entity of PC5 interface removes the SRAP header in accordance with clause 5.2.2. As an alternative for handling DL data packet corresponding to SRB0 not shown in Figure 4.2.2-2 or Figure 4.2.2-3, the receiving part on the SRAP entity of Uu or PC5 interface removes the SRAP header and delivers SRAP SDUs to the transmitting part on the collocated SRAP entity of PC5 interface.

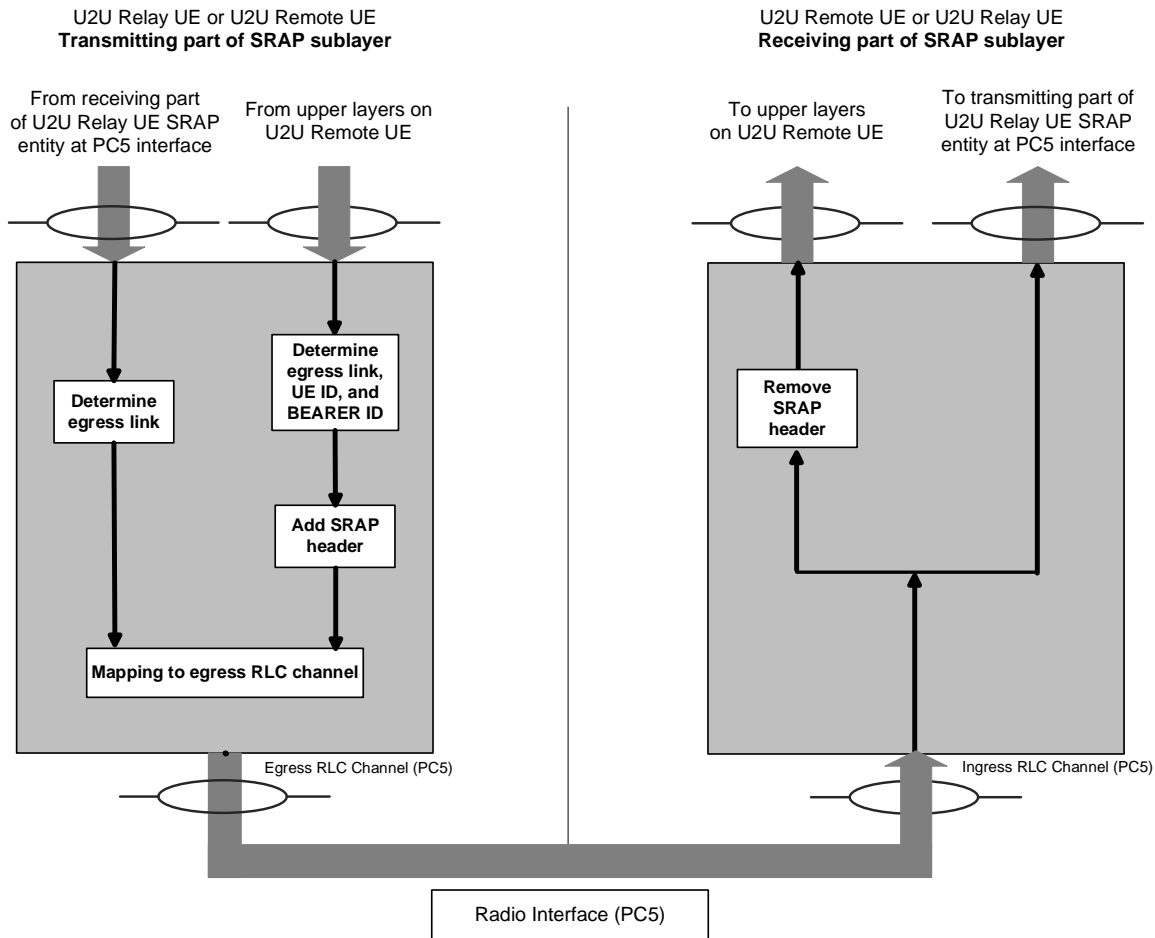

**Figure 4.2.2-4: Example of functional view of SRAP sublayer at PC5 interface in U2U Relay case**

In the example of Figure 4.2.2-4, at U2U relay UE:

- For U2U data packet, the receiving part on the SRAP entity of PC5 interface between the U2U Relay UE and the U2U Remote UE delivers U2U SRAP Data PDUs to the transmitting part on the SRAP entity of PC5 interface between the U2U Relay UE and the peer U2U Remote UE. As an alternative, the receiving part may deliver SRAP SDUs to the transmitting part on the SRAP entity. When passing SRAP SDUs, the receiving part removes the SRAP header and the transmitting part of the relay UE adds the SRAP header with the same SRAP header content as carried on the U2U SRAP Data PDU header prior to removal. Passing SRAP SDUs in this manner is therefore functionally equivalent to passing U2U SRAP Data PDUs, in implementation. The following specification therefore refers to the passing of SRAP data packets.

## 4.3 Services

### 4.3.1 Services provided to upper layers

The following services are provided by the SRAP sublayer to upper layers:

- Data transfer.

### 4.3.2 Services expected from lower layers

An SRAP sublayer expects the following services from lower layers per RLC entity (for a detailed description see TS 38.322 [4]):

- Acknowledged data transfer service;

- Unacknowledged data transfer service.

## 4.4 Functions

The SRAP sublayer supports the following functions:

- Data transfer;
- Determination of UE ID field and BEARER ID field for data packets;
- Determination of egress link;
- Determination of egress RLC channel.

## 4.5 Configurations

The configuration of the SRAP entity for U2N Remote UE includes:

- Mapping from a radio bearer identified by BEARER ID field to egress PC5 Relay RLC channel via RRC;
- The local identity via RRC.

The configuration of the SRAP entity for U2N Relay UE includes:

- The local identity for each directly and indirectly connected (if any) U2N Remote UE via RRC;
- Mapping from a radio bearer identified by UE ID field and BEARER ID field to egress Uu Relay RLC channel for each U2N Remote UE via RRC;
- Mapping from a radio bearer identified by UE ID field and BEARER ID field to egress PC5 Relay RLC channel for each U2N Remote UE via RRC.

The configuration of the SRAP entity for U2U Remote UE includes:

- Mapping from a sidelink radio bearer identified by BEARER ID field to egress PC5 Relay RLC channel for each U2U Remote UE pair;
- The local identities.

The configuration of the SRAP entity for U2U Relay UE includes:

- Mapping from a sidelink radio bearer identified by BEARER ID field to egress PC5 Relay RLC channel for each U2U Remote UE pair and each direction of data transfer.

---

# 5 Procedures

## 5.1 SRAP entity handling

### 5.1.1 SRAP entity establishment

When upper layers request establishment of an SRAP entity, UE shall:

- Establish an SRAP entity;
- Follow the procedures in clause 5.

### 5.1.2 SRAP entity release

When upper layers request release of an SRAP entity, UE shall:

- Release the SRAP entity and the related SRAP configurations.

## 5.2 DL Data transfer

### 5.2.1 Receiving operation of U2N Relay UE

Upon receiving an SRAP Data PDU from lower layer, the receiving part of the SRAP entity on the Uu interface of U2N Relay UE shall:

- Deliver the SRAP data packet to the transmitting part of the collocated SRAP entity on the PC5 interface.

#### 5.2.1a Receiving operation of Intermediate U2N Relay UE

Upon receiving an SRAP Data PDU from lower layer, the receiving part of the SRAP entity on the PC5 interface of U2N Relay UE shall:

- If the UE ID field in the SRAP Data PDU matches *sl-LocalIdentity* configured in *sl-L2RemoteUE-Config*:
  - Perform receiving operation of U2N Remote UE in accordance with clause 5.2.3;
- Else
  - Deliver the SRAP data packet to the transmitting part of the collocated SRAP entity on the PC5 interface and perform transmitting operation of U2N Relay UE in accordance with clause 5.2.2.

### 5.2.2 Transmitting operation of U2N Relay UE

#### 5.2.2.0 General

The transmitting part of the SRAP entity on the PC5 interface of U2N Relay UE receives SRAP data packets from the receiving part of the SRAP entity on the Uu or PC5 interface of the same U2N Relay UE, and construct SRAP Data PDUs as needed (see clause 4.2.2).

When the transmitting part of the SRAP entity on the PC5 interface has an SRAP Data PDU to transmit, the transmitting part of the SRAP entity on the PC5 interface shall:

- Determine the egress link in accordance with clause 5.2.2.1;
- Determine the egress RLC channel in accordance with clause 5.2.2.2;
- If the SRAP Data PDU is for SRB0 of the Child UE (for single-hop U2N Relay case, the BEARER ID field is 0, and the bearer is identified as SRB based on *sl-RemoteUE-RB-Identity* associated with the entry containing the *sl-EgressRLC-ChannelUu* which matches the LCID of the Uu Relay RLC Channel from which the SRAP Data PDU is received; or for multi-hop U2N Relay, the UE ID field matches the *sl-LocalIdentity* configured in *sl-SRAP-ConfigRelay*, BEARER ID field is 0, and the bearer is identified as SRB based on *sl-RemoteUE-RB-Identity* associated with the entry containing either the *sl-EgressRLC-Channel-UL* which matches the LCID of the PC5 Relay RLC Channel or the *sl-EgressRLC-Channel-Uu* which matches the LCID of the Uu Relay RLC Channel from which the SRAP Data PDU is received):
  - Remove the SRAP header from the SRAP Data PDU;
- Submit this SRAP Data PDU to the determined egress RLC channel of the determined egress link.

#### 5.2.2.1 Egress link determination

For a SRAP Data PDU to be transmitted, SRAP entity shall:

- If there is an entry in *sl-RemoteUE-ToAddModList*, whose *sl-LocalIdentity* included in *sl-SRAP-ConfigRelay* or *sl-SRAP-ConfigRelay-ToAddModList* matches the UE ID field in SRAP Data PDU:

- Determine the egress link on PC5 interface corresponding to *sl-L2IdentityRemote* configured for the concerned *sl-LocalIdentity* as specified in TS 38.331 [3].

### 5.2.2.2 Egress RLC channel determination

For a SRAP Data PDU to be transmitted, the SRAP entity shall:

- If the SRAP Data PDU is for SRB0 of the Child UE (for single-hop U2N Relay case, the BEARER ID field is 0 and the bearer is identified as SRB based on *sl-RemoteUE-RB-Identity* associated with the entry containing the *sl-EgressRLC-ChannelUu* which matches the LCID of the Uu Relay RLC Channel from which the SRAP Data PDU is received; or for multi-hop U2N Relay case, the UE ID field matches the *sl-LocalIdentity* configured in *sl-SRAP-ConfigRelay*, BEARER ID field is 0, and the bearer is identified as SRB based on *sl-RemoteUE-RB-Identity* associated with the entry containing either the *sl-EgressRLC-Channel-UL* which matches the LCID of the PC5 Relay RLC Channel or the *sl-EgressRLC-Channel-Uu* which matches the LCID of the Uu Relay RLC Channel from which the SRAP Data PDU is received):
  - Determine the egress PC5 Relay RLC channel in the determined egress link corresponding to *logicalChannelIdentity* for SL-RLC0 as specified in TS 38.331 [3].
- Else if there is an entry in *sl-RemoteUE-ToAddModList*, whose *sl-LocalIdentity* included in *sl-SRAP-ConfigRelay* or *sl-SRAP-ConfigRelay-ToAddModList* matches the UE ID field in SRAP Data PDU, which includes an *sl-RemoteUE-RB-Identity* that matches the SRB identity or DRB identity of the SRAP Data PDU determined by the BEARER ID field (For the BEARER ID shared by both SRB and DRB, SRB and DRB are differentiated based on *sl-RemoteUE-RB-Identity* associated with the entry containing the *sl-EgressRLC-ChannelUu* which matches the LCID of the Uu Relay RLC Channel or *sl-EgressRLC-Channel-UL* which matches the LCID of the PC5 Relay RLC Channel from which the SRAP Data PDU is received, and for DRB, the DRB identity is BEARER ID plus 1):
  - If the SRAP Data PDU is for SRB1 but the corresponding *sl-EgressRLC-ChannelPC5* is absent in *sl-SRAP-ConfigRelay* or *sl-EgressRLC-Channel-DL* in *sl-SRAP-ConfigRelay-ToAddModList* is absent:
    - Determine the egress PC5 Relay RLC channel in the determined egress link corresponding to *logicalChannelIdentity* for SL-RLC1 as specified in TS 38.331 [3].
  - Else:
    - Determine the egress PC5 Relay RLC channel in the determined egress link corresponding to *sl-EgressRLC-ChannelPC5* or *sl-EgressRLC-Channel-DL* configured for the concerned *sl-LocalIdentity* and concerned *sl-RemoteUE-RB-Identity* as specified in TS 38.331 [3].

### 5.2.3 Receiving operation of U2N Remote UE

Upon receiving an SRAP Data PDU from lower layer, the receiving part of the SRAP entity shall:

- If the SRAP Data PDU is not for SRB0 (not received from SL-RLC0 as specified in TS 38.331 [3]):
  - If the SRAP Data PDU is received from SL-RLC1 as specified in TS 38.331 [3]:
    - Remove the SRAP header of this SRAP Data PDU and deliver the SRAP SDU to PDCP entity of SRB1 by ignoring the UE ID field and BEARER ID field of this SRAP Data PDU;
  - Else:
    - Remove the SRAP header of this SRAP Data PDU and deliver the SRAP SDU to upper layer entity corresponding to the BEARER ID field of this SRAP Data PDU (For the BEARER ID shared by both SRB and DRB, SRB and DRB are differentiated based on *sl-RemoteUE-RB-Identity* associated with the entry containing the *sl-EgressRLC-ChannelPC5* which matches LCID of the PC5 Relay RLC Channel from which the SRAP Data PDU is received, and for DRB, the DRB identity is BEARER ID plus 1);
- Else:
  - Deliver the SRAP SDU (i.e., same as SRAP PDU for SRB0) to upper layer, i.e., RRC layer entity (TS 38.331 [3]).

## 5.3 UL Data transfer

### 5.3.1 Transmitting operation of U2N Remote UE

The transmitting part of the SRAP entity on the PC5 interface of U2N Remote UE can receive SRAP SDU from upper layer and constructs SRAP Data PDU.

Upon receiving an SRAP SDU from upper layer, the transmitting part of the SRAP entity on the PC5 interface shall:

- If the SRAP SDU is not for SRB0:
  - Determine the UE ID field and BEARER ID field in accordance with clause 5.3.1.1;
  - Construct an SRAP Data PDU with SRAP header, where the UE ID field and BEARER ID field are set to the determined values, in accordance with clause 6.2.2;
- Else:
  - Construct an SRAP Data PDU without SRAP header in accordance with clause 6.2.2.
- Determine the egress RLC channel in accordance with clause 5.3.1.2;
- Submit this SRAP Data PDU to the determined egress RLC channel.

#### 5.3.1.1 UE ID field and BEARER ID field determination

For an SRAP SDU received from upper layer, the SRAP entity shall:

- Determine the UE ID field corresponding to *sl-LocalIdentity*, configured as specified in TS 38.331 [3];
- Determine the BEARER ID field corresponding to SRB identity for SRB (i.e., set the BEARER ID field to *srb-Identity*), or corresponding to DRB identity minus 1 for DRB (i.e., set the BEARER ID field to *drb-Identity* minus 1), from which the SRAP SDU is received, configured as specified in TS 38.331 [3].

#### 5.3.1.2 Egress RLC channel determination

For a SRAP Data PDU to be transmitted, the SRAP entity shall:

- If the SRAP Data PDU is for SRB0:
  - Determine the egress PC5 Relay RLC channel in the link with U2N Relay UE corresponding to *logicalChannelIdentity* for SL-RLC0 as specified in TS 38.331 [3].
- Else if the SRAP Data PDU is for SRB1 and if there is not an entry in *sl-MappingToAddModList*, whose *sl-RemoteUE-RB-Identity* matches the SRB identity of the SRAP Data PDU, or if there is an entry in *sl-MappingToAddModList* without the corresponding *sl-EgressRLC-ChannelPC5*:
  - Determine the egress PC5 Relay RLC channel in the link with U2N Relay UE corresponding to *logicalChannelIdentity* for SL-RLC1 as specified in TS 38.331 [3].
- Else if there is an entry in *sl-MappingToAddModList*, whose *sl-RemoteUE-RB-Identity* matches the SRB identity or DRB identity of the SRAP Data PDU:
  - Determine the egress PC5 Relay RLC channel of the link with U2N Relay UE corresponding to *sl-EgressRLC-ChannelPC5* configured for the concerned *sl-RemoteUE-RB-Identity* as specified in TS 38.331 [3].

### 5.3.2 Receiving operation of U2N Relay UE

Upon receiving an SRAP Data PDU from lower layer, the receiving part of the SRAP entity on the PC5 interface shall:

- Deliver the SRAP data packet to the transmitting part of the collocated SRAP entity on the Uu or PC5 interface.

### 5.3.3 Transmitting operation of U2N Relay UE

The transmitting part of the SRAP entity on the Uu or PC5 interface of U2N Relay UE can receive SRAP data packets from the receiving part of the SRAP entity on the PC5 interface of the same U2N Relay UE, and construct SRAP Data PDUs as needed (see clause 4.2.2).

When the transmitting part of the SRAP entity on the Uu or PC5 interface has an SRAP Data PDU to transmit, the transmitting part of the SRAP entity on the Uu or PC5 interface shall:

- If the SRAP Data PDU is received from SL-RLC0 as specified in TS 38.331 [3]:
  - Determine the UE ID field and BEARER ID field in accordance with clause 5.3.3.1;
  - Construct an SRAP Data PDU with SRAP header, where the UE ID field and BEARER ID field are set to the determined values, in accordance with clause 6.2.2;
- Determine the egress RLC channel in accordance with clause 5.3.3.2;
- Submit this SRAP Data PDU to the determined egress RLC channel.

#### 5.3.3.1 UE ID field and BEARER ID field determination

For an SRAP Data PDU received from SL-RLC0 as specified in TS 38.331 [3], the SRAP entity shall:

- If there is an entry in *sl-RemoteUE-ToAddModList*, whose *sl-L2IdentityRemote* matches the Layer-2 ID of the remote UE from which the SRAP Data PDU is received:
  - Determine the UE ID field corresponding to *sl-LocalIdentity* configured for the concerned *sl-L2IdentityRemote* as specified in TS 38.331 [3];
  - Determine the BEARER ID field as 0 (i.e., set BEARER ID field as 0).

#### 5.3.3.2 Egress RLC channel determination

For a SRAP Data PDU to be transmitted, the SRAP entity shall:

- If there is an entry in *sl-RemoteUE-ToAddModList*, whose *sl-LocalIdentity* included in *sl-SRAP-ConfigRelay* or *sl-SRAP-ConfigRelay-ToAddModList* matches the UE ID field in SRAP Data PDU:
  - If the SRAP Data PDU is for SRB0:
    - Determine the egress Uu/PC5 Relay RLC channel corresponding to *sl-EgressRLC-ChannelUu* or *sl-EgressRLC-Channel-UL* configured for SRB0 for the concerned *sl-LocalIdentity* as specified in TS 38.331 [3].
  - Else if the SRAP Data PDU is received from SL-RLC1 as specified in TS 38.331 [3]:
    - Determine the egress Uu/PC5 Relay RLC channel corresponding to *sl-EgressRLC-ChannelUu* or *sl-EgressRLC-Channel-UL* configured for SRB1 for the concerned *sl-LocalIdentity* as specified in TS 38.331 [3]. Or determine the egress PC5 Relay RLC channel corresponding to *logicalChannelIdentity* for SL-RLC1 as specified in TS 38.331 [3] if the corresponding *sl-EgressRLC-Channel-UL* is absent in *sl-SRAP-ConfigRelay-ToAddModList*.
  - Else if there is an entry in *sl-RemoteUE-ToAddModList* which includes an *sl-RemoteUE-RB-Identity* matches SRB identity or DRB identity of the SRAP Data PDU determined by the BEARER ID field (For the BEARER ID shared by both SRB and DRB, SRB and DRB are differentiated based on *sl-RemoteUE-RB-Identity* associated with the entry containing the *sl-EgressRLC-ChannelPC5* or *sl-EgressRLC-Channel-DL* which matches LCID of the PC5 Relay RLC Channel from which the SRAP Data PDU is received, and for DRB, the DRB identity is BEARER ID plus 1):
    - Determine the egress Uu/PC5 Relay RLC channel corresponding to *sl-EgressRLC-ChannelUu* or *sl-EgressRLC-Channel-UL* configured for the concerned *sl-LocalIdentity* and concerned *sl-RemoteUE-RB-Identity* as specified in TS 38.331 [3].

## 5.3a U2U SL Data transfer

### 5.3a.1 Transmitting operation of U2U Remote UE

#### 5.3a.1.1 General

The transmitting part of the SRAP entity on the PC5 interface of U2U Remote UE can receive SRAP SDU from upper layer and construct U2U SRAP Data PDU.

Upon receiving an SRAP SDU from upper layer, the transmitting part of the SRAP entity on the PC5 interface shall:

- Determine the UE ID fields, egress link and BEARER ID field in accordance with clause 5.3a.1.2;
- Construct a U2U SRAP Data PDU with SRAP header, where the UE ID fields and BEARER ID field are set to the determined values, in accordance with clause 6.2.2;
- Determine the egress RLC channel in accordance with clause 5.3a.1.3;
- Submit this U2U SRAP Data PDU to the determined egress PC5 Relay RLC channel of the determined egress link.

#### 5.3a.1.2 Egress link, UE ID fields and BEARER ID field determination

For a U2U SRAP SDU received from upper layer, the SRAP entity shall:

- Determine the egress link on PC5 interface towards the U2U relay UE based on the concerned *sl-RemoteUE-L2Identity* and *sl-PeerRemoteUE-L2Identity* as specified in TS 38.331 [3];
- Determine the UE ID (for SRC) field corresponding to *sl-RemoteUE-LocalIdentity* configured for the concerned *sl-RemoteUE-L2Identity* and UE ID (for DST) field corresponding to *sl-PeerRemoteUE-LocalIdentity* configured for the concerned *sl-PeerRemoteUE-L2Identity* as specified in TS 38.331 [3];
- Determine the BEARER ID field for SL-SRBs as the fixed value (i.e., set 0/1/2/3 for SL-SRB0/1/2/3 respectively) or for SL-DRBs as the 5 LSBs of *slrb-PC5-ConfigIndex* used in end-to-end SL DRB configuration procedure as specified in TS 38.331 [3].

#### 5.3a.1.3 Egress RLC channel determination

For a U2U SRAP Data PDU to be transmitted, the SRAP entity shall:

- If the U2U SRAP Data PDU is for SL SRB (i.e., the BEARER ID field is 0/1/2/3):
  - Determine the egress PC5 Relay RLC channel in the determined egress link corresponding to *logicalChannelIdentity* for SL-U2U-RLC as specified in TS 38.331 [3].
- Else if the U2U SRAP Data PDU is for SL DRB:
  - Determine the egress PC5 Relay RLC channel in the determined egress link corresponding to SRAP configuration indicated by upper layer for the concerned bearer as specified in TS 38.331 [3].

### 5.3a.2 Receiving operation of U2U Relay UE

Upon receiving a U2U SRAP Data PDU from lower layer, the receiving part of the SRAP entity on the PC5 interface between the U2U Relay UE and the U2U Remote UE shall:

- Deliver the SRAP data packet to the transmitting part of the SRAP entity on the PC5 interface between the U2U Relay UE and the peer U2U Remote UE.

### 5.3a.3 Transmitting operation of U2U Relay UE

#### 5.3a.3.1 General

The transmitting part of the SRAP entity of U2U Relay UE on the PC5 interface between the U2U Relay UE and the peer U2U Remote UE can receive SRAP data packets from the receiving part of the SRAP entity of the same U2U Relay UE on the PC5 interface between the U2U Relay UE and the U2U Remote UE, and construct U2U SRAP Data PDUs as needed (see clause 4.2.2).

When the transmitting part of the SRAP entity of the U2U Relay UE has a U2U SRAP Data PDU to transmit on the PC5 interface between U2U Relay UE and the peer U2U Remote UE, the transmitting part of the SRAP entity of U2U Relay UE shall:

- Determine the egress link in accordance with clause 5.3a.3.2;
- Determine the egress RLC channel in accordance with clause 5.3a.3.3;
- Submit this U2U SRAP Data PDU to the determined egress RLC channel of the determined egress link.

#### 5.3a.3.2 Egress link determination

For a U2U SRAP Data PDU to be transmitted, the SRAP entity shall:

- If there is an entry in *sl-LocalID-PairList*, in which the *sl-RemoteUE-LocalIdentity* and *sl-PeerRemoteUE-LocalIdentity* match the UE ID fields in the U2U SRAP Data PDU:
  - Determine the egress link on PC5 interface towards the peer U2U remote UE identified by *sl-PeerRemoteUE-L2Identity* configured for the concerned *sl-PeerRemoteUE-LocalIdentity* as specified in TS 38.331 [3].

#### 5.3a.3.3 Egress RLC channel determination

For a U2U SRAP Data PDU to be transmitted, the SRAP entity shall:

- If the U2U SRAP Data PDU is for SRB (i.e., the BEARER ID field is 0/1/2/3):
  - Determine the egress PC5 Relay RLC channel in the determined egress link corresponding to *logicalChannellIdentity* for SL-U2U-RLC as specified in TS 38.331 [3].
- Else if the U2U SRAP Data PDU is for DRB:
  - Determine the egress PC5 Relay RLC channel in the determined egress link corresponding to SRAP configuration indicated by upper layer for the concerned bearer as specified in TS 38.331 [3].

### 5.3a.4 Receiving operation of U2U Remote UE

Upon receiving a U2U SRAP Data PDU from lower layer, the receiving part of the SRAP entity shall:

- Remove the SRAP header of this U2U SRAP Data PDU and deliver the U2U SRAP SDU to upper layer entity corresponding to the BEARER ID and UE ID fields of this U2U SRAP Data PDU.

## 5.4 Handling of unknown, unforeseen, and erroneous protocol data

For U2N Remote UE (includes Intermediate U2N Relay UE acting as U2N Remote UE), if *sl-LocalIdentity* and *sl-RemoteUE-RB-Identity* are both configured, when a SRAP Data PDU with SRAP header that contains a UE ID field or BEARER ID field which does not match *sl-LocalIdentity* or *sl-RemoteUE-RB-Identity* included in *sl-SRAP-ConfigRemote* is received, the SRAP entity shall:

- Discard the received SRAP Data PDU.

For U2N Relay UE, when a SRAP Data PDU with SRAP header that contains a UE ID field or BEARER ID field which does not match *sl-LocalIdentity* or *sl-RemoteUE-RB-Identity* included in *sl-SRAP-ConfigRelay* or *sl-SRAP-ConfigRelay-ToAddModList* is received except in the case where the SRAP Data PDU from SL-RLC1 as specified in TS 38.331 [3] is the first SRAP Data PDU received from a U2N Remote UE, or when a SRAP Data PDU that contains a UE ID which does not match the concerned *sl-LocalIdentity* included in *sl-SRAP-ConfigRelay* or *sl-SRAP-ConfigRelay-ToAddModList* associated with *sl-L2IdentityRemote* of the ingress link is received by U2N Relay UE, the SRAP entity shall:

- Discard the received SRAP Data PDU.

For U2U Remote UE, if *sl-RemoteUE-LocalIdentity* and *sl-PeerRemoteUE-LocalIdentity* are both configured, when an SRAP Data PDU with SRAP header that contains UE ID fields which does not match *sl-PeerRemoteUE-LocalIdentity* and *sl-RemoteUE-LocalIdentity* included in any one of the entries in *sl-LocalID-PairList* is received or when an SRAP Data PDU with SRAP header that contains BEARER ID field which does not match 0/1/2/3 or any of the 5 bits LSBs of *slrb-PC5-ConfigIndex* used on the end-to-end PC5 connection indicated by *sl-RemoteUE-LocalIdentity* and *sl-PeerRemoteUE-LocalIdentity* is received, the SRAP entity shall:

- Discard the received SRAP Data PDU.

For U2U Relay UE, when an SRAP Data PDU with SRAP header that contains a UE ID (for DST) field which does not match *sl-PeerRemoteUE-LocalIdentity* included in any one of the entries in *sl-LocalID-PairList* is received, or when an SRAP Data PDU that contains a UE ID (for SRC) field which does not match the concerned *sl-RemoteUE-LocalIdentity* corresponding to *sl-RemoteUE-L2Identity* of the ingress link in any one of the entries in *sl-LocalID-PairList* with matched *sl-PeerRemoteUE-LocalIdentity* and *sl-PeerRemoteUE-L2Identity* is received, or when an SRAP Data PDU with SRAP header that contains BEARER ID field which does not match 0/1/2/3 or any of the 5 bits LSBs of *slrb-PC5-ConfigIndex* used on the end-to-end PC5 connection indicated by *sl-RemoteUE-LocalIdentity* and *sl-PeerRemoteUE-LocalIdentity* is received by U2U Relay UE, the SRAP entity shall:

- Discard the received SRAP Data PDU.

When any of the U2N Remote UE, the U2N Relay UE, the U2U Remote UE or the U2U Relay UE receives an SRAP Data PDU with invalid or reserved values, the SRAP entity shall:

- Discard the received SRAP Data PDU.

---

## 6 Protocol data units, formats, and parameters

### 6.1 Protocol data units

#### 6.1.1 Data PDU

The SRAP Data PDU is used to convey the following with or without the PDU header:

- Upper layer data.

### 6.2 Formats

#### 6.2.1 General

An SRAP Data PDU is a bit string that is byte aligned (i.e. multiple of 8 bits) in length. The formats of SRAP Data PDUs are described in clause 6.2.2 and their parameters are described in clause 6.3.

#### 6.2.2 Data PDU

Figure 6.2.2-1 shows the format of the U2N SRAP Data PDU with SRAP header being configured. This SRAP Data PDU format is applicable to U2N SRAP SDU except those for SRB0 delivered over PC5 interface via SL-RLC0.

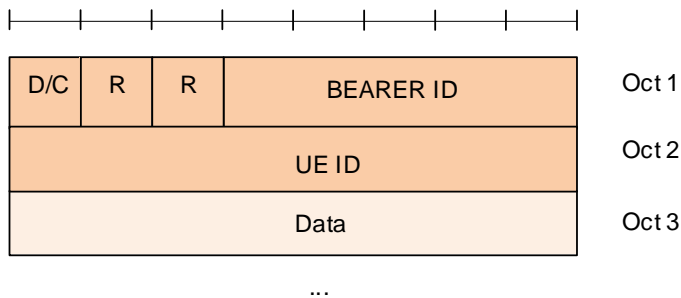

**Figure 6.2.2-1: U2N SRAP Data PDU format with SRAP header**

Figure 6.2.2-2 shows the format of the U2N SRAP Data PDU consisting only of a data field without any SRAP header. This SRAP Data PDU format is applicable to U2N SRAP SDU for SRB0 delivered over PC5 interface via SL-RLC0.

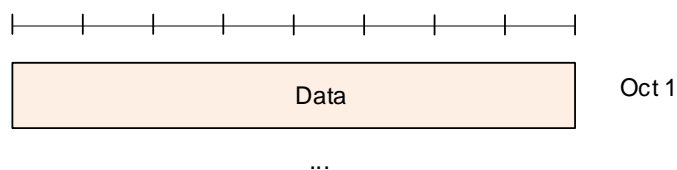

**Figure 6.2.2-2: U2N SRAP Data PDU format without SRAP header**

Figure 6.2.2-3 shows the format of the U2U SRAP Data PDU. This SRAP Data PDU format is applicable to U2U SRAP SDU delivered over PC5 interface.

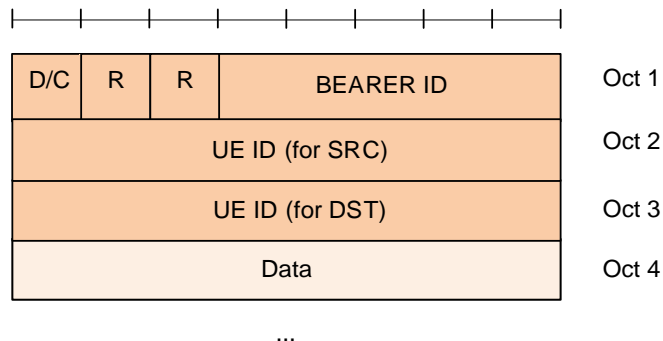

**Figure 6.2.2-3: U2U SRAP Data PDU format with SRAP header**

## 6.3 Parameters

### 6.3.1 General

If not otherwise mentioned in the definition of each field the bits in the parameters shall be interpreted as follows: the left most bit is the first and most significant and the right most bit is the last and least significant bit.

Unless otherwise mentioned, integers are encoded in standard binary encoding for unsigned integers. In all cases the bits appear ordered from MSB to LSB when read in the PDU.

### 6.3.2 UE ID

Length: 8 bits.

In U2N Relay case, this field carries local identity of U2N Remote UE. In U2U Relay case, there are two UE ID fields: the first one carrying the local identity of SRC U2U Remote UE, the second one carrying the local identity of DST U2U Remote UE.

### 6.3.3 BEARER ID

Length: 5 bits.

In U2N Relay case, this field carries information to identify Uu radio bearer for U2N Remote UE. For SRBs, the value is set to SRB Identity (which is configured by RRC parameter *srb-Identity*). For DRBs, the value is set to DRB Identity (which is configured by RRC parameter *drb-Identity*) minus 1.

In U2U Relay case, this field carries information to identify end-to-end PC5 radio bearer for U2U Remote UE. For SL-SRBs, the value is set to 0/1/2/3 for SL-SRB 0/1/2/3 respectively. For SL-DRBs, the value is set to the 5 LSBs of *slrb-PC5-ConfigIndex* used in end-to-end SL DRB configuration procedure as specified in TS 38.331 [3].

### 6.3.4 Data

Length: Variable

This field carries the SRAP SDU (i.e. PDCP PDU or RRC PDU).

### 6.3.5 R

Length: 1 bit

Reserved. In this release, reserved bits shall be set to 0. Reserved bits shall be ignored by the receiver.

### 6.3.6 D/C

Length: 1 bit

This field indicates whether the corresponding SRAP PDU is an SRAP Data PDU or an SRAP Control PDU (not used in this release).

**Table 6.3.6-1: D/C field**

Bit	Description
0	SRAP Data PDU
1	SRAP Control PDU (not used in this release)

## Annex A (informative): Change history

Change history							
Date	Meeting	TDoc	CR	Rev	Cat	Subject/Comment	New version
11/2021	RAN2#1 16	R2-2109400				Skeleton	0.0.0
11/2021	RAN2#1 16	R2-2111485				Skeleton update	0.0.1
11/2021	RAN2#1 16	R2-2111489				Capture the agreement till R2#116	0.1.0
01/2022	RAN2#1 16bis	R2-2200364				Capture the agreement till R2#116 that related to the 38.331 running CR	0.2.0
01/2022	RAN2#1 16bis	R2-2201996				Capture the agreement during R2#116bis	0.3.0
02/2022	RAN2#1 17	R2-2202276				Capture the agreement till R2#116bis that related to the 38.331 running CR	0.4.0
02/2022	RAN2#1 17	R2-2203594				Capture the agreement during R2#117	0.5.0
03/2022	RAN#95	RP-220794				Submit to RAN for approval	1.0.0
03/2022	RP-95					Upgraded to Rel-17 by MCC	17.0.0
06/2022	RP-96	RP-221732	0001	1	F	Correction on SRAP for L2 UE-to-Network Relay	17.1.0
09/2022	RP-97	RP-222524	0009	2	F	Correction on SRAP for L2 U2N Relay	17.2.0
12/2022	RP-98	RP-223412	0012	2	F	Corrections for L2 U2N Relay	17.3.0
03/2023	RP-99	RP-230692	0015	1	F	Corrections on SRAP for SL relay	17.4.0
	RP-99	RP-230692	0016	1	F	Correction to error handling in SRAP	17.4.0
	RP-99	RP-230692	0017	2	F	Correction on SRAP for L2 U2N Relay	17.4.0
	RP-99	RP-230692	0018	-	F	38.351 SRAP corrections	17.4.0
06/2023	RP-100	RP-231416	0020	3	F	Corrections on SRAP for SL relay	17.5.0
	RP-100	RP-231416	0021	1	F	Corrections on SRAP for SL relay	17.5.0
	RP-100	RP-231416	0022	1	F	Clarification on the SRAP configuration used in SRAP	17.5.0
09/2023	RP-101	RP-232667	0023	-	F	Correction of IE name sl-SRAP-ConfigRemote	17.6.0
	RP-101	RP-232667	0024	2	F	Correction on SRAP for sidelink relay	17.6.0
	RP-101	RP-232667	0025	1	F	Clarification on the BEARER ID in SRAP data PDU	17.6.0
12/2023	RP-102	RP-233904	0027	3	B	Introduction of NR sidelink relay enhancements	18.0.0
03/2024	RP-103	RP-240700	0030	1	F	Corrections for NR sidelink relay enhancements	18.1.0
	RP-103	RP-240657	0032	2	A	Miscellaneous corrections for NR sidelink relay enhancements	18.1.0
06/2024	RP-104	RP-241569	0034	3	F	Corrections for NR sidelink relay enhancements	18.2.0
12/2024	RP-106	RP-243232	0037	2	F	Correction to error handling for U2U operation	18.3.0
06/2025	RP-108	RP-251693	0039	1	A	Correction of egress Uu RLC channel determination for L2 U2N Relay UE	18.4.0
	RP-108	RP-251695	0040	1	F	Correction on terminology of local ID pair list	18.4.0
09/2025	RP-109	RP-252780	0041	2	B	Introduction of NR sidelink multi-hop relay in TS 38.351	19.0.0
12/2025	RP-110	RP-253731	0042	2	F	Miscellaneous SRAP corrections for multi-hop U2N Relay	19.1.0

---

## History

<b>Version</b>	<b>Date</b>	<b>Status</b>
V19.0.0	October 2025	Publication
V19.1.0	February 2026	Publication